

CIR.	GA.	COLOR
A-1	12	RED
A-1B	16	DARK BLUE WITH TRACER
B-1	18	BLACK WITH WHITE TRACER
B-2	18	BLACK WITH WHITE TRACER
D-5	18	TAN
D-6	18	LIGHT GREEN
G-2	18	VIOLET
G-6	18	GRAY
H-1	14	VIOLET
H-2	16	DARK GREEN
H-2A	16	DARK GREEN
H-3	18	BLACK WITH TRACER
J-2	16	DARK BLUE
J-2A	14	DARK BLUE
J-3	18	BROWN
L-3A	16	RED
L-3B	16	RED
L-3C	16	RED
L-4	16	BLACK
L-4A	16	BLACK
L-6	18	YELLOW WITH TRACER
L-6A	18	YELLOW
L-9	16	WHITE
L-9A	16	WHITE
L-9B	16	WHITE
L-9C	16	WHITE
R-3	18	DARK GREEN
R-4	16	BROWN
R-5	18	DARK BLUE
R-6	12	BLACK
S-2	18	YELLOW
S-4	16	BROWN
S-4A	16	BROWN
S-5	12	BROWN
V-10	18	TAN WITH TRACER
X-27	16	BLACK

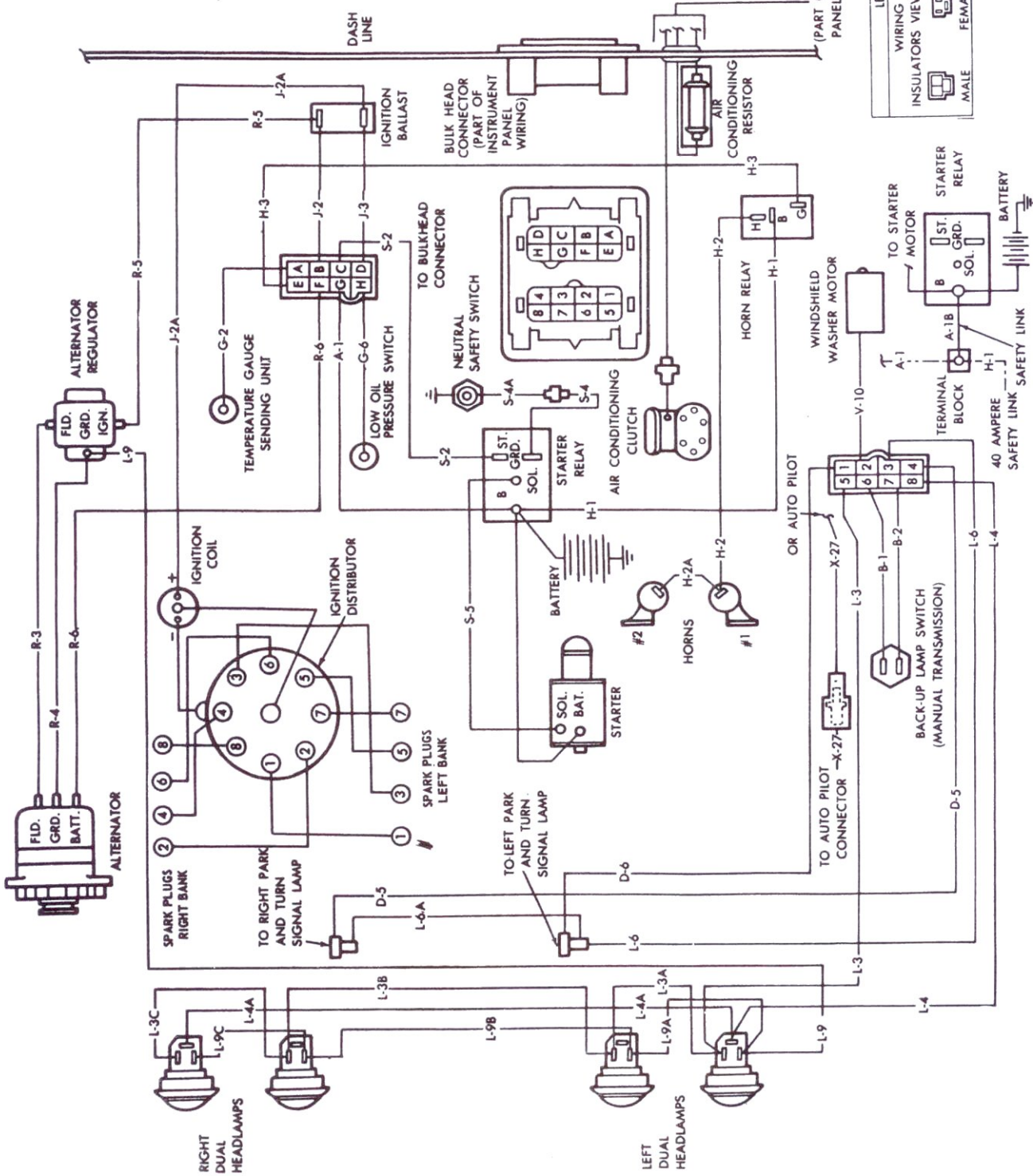

**LEGEND**

WIRING SPLICE

INSULATORS VIEWED FROM TERMINAL SIDE

MALE FEMALE

Engine Compartment Wiring Diagram

CIRCUITS	
CIR.	GAL COLOR
B-2	18 WHITE
B-2A	18 WHITE
B-2B	18 WHITE
C-11	18 BLACK
C-12	20 WHITE
C-13	18 BLACK
C-13A	14 BLACK

CIRCUITS	
CIR.	GAL COLOR
C-14	14 BLACK
C-20	16 BROWN
C-22	16 DARK GREEN
C-24	16 BLACK
D-7	18 BROWN
D-8	18 DARK GREEN
G-4	18 LIGHT BLUE
L-7	18 BLACK
L-7A	18 BLACK
L-7B	18 BLACK
L-7C	18 BLACK
L-7D	18 BLACK
M-1	18 PINK
M-1A	18 PINK
M-1B	18 PINK
M-1C	18 PINK
M-1D	18 PINK
M-1E	18 PINK
M-1F	18 PINK
M-1G	18 PINK
M-1H	18 PINK
M-1J	18 PINK
M-1M	18 PINK
M-1N	18 PINK
M-2	18 YELLOW
M-2A	18 YELLOW
M-2B	18 YELLOW
M-2C	18 YELLOW
M-2D	18 YELLOW
M-2E	18 YELLOW
M-2F	18 YELLOW
M-2J	18 YELLOW
M-2K	18 BLACK
M-2L	18 BLACK
M-2M	18 YELLOW
M-2N	18 YELLOW
M-11	18 PINK
M-11A	18 PINK
M-12	18 YELLOW
T-1	12 RED
T-2	12 BROWN
T-2A	12 RED
T-3	12 YELLOW
T-3A	12 YELLOW
T-4	12 BLACK
X-2	18 WHITE
X-3	14 LIGHT GREEN
X-3A	14 LIGHT GREEN
X-3C	14 LIGHT GREEN
X-3D	14 LIGHT GREEN
X-13	18 BROWN
X-14	18 YELLOW

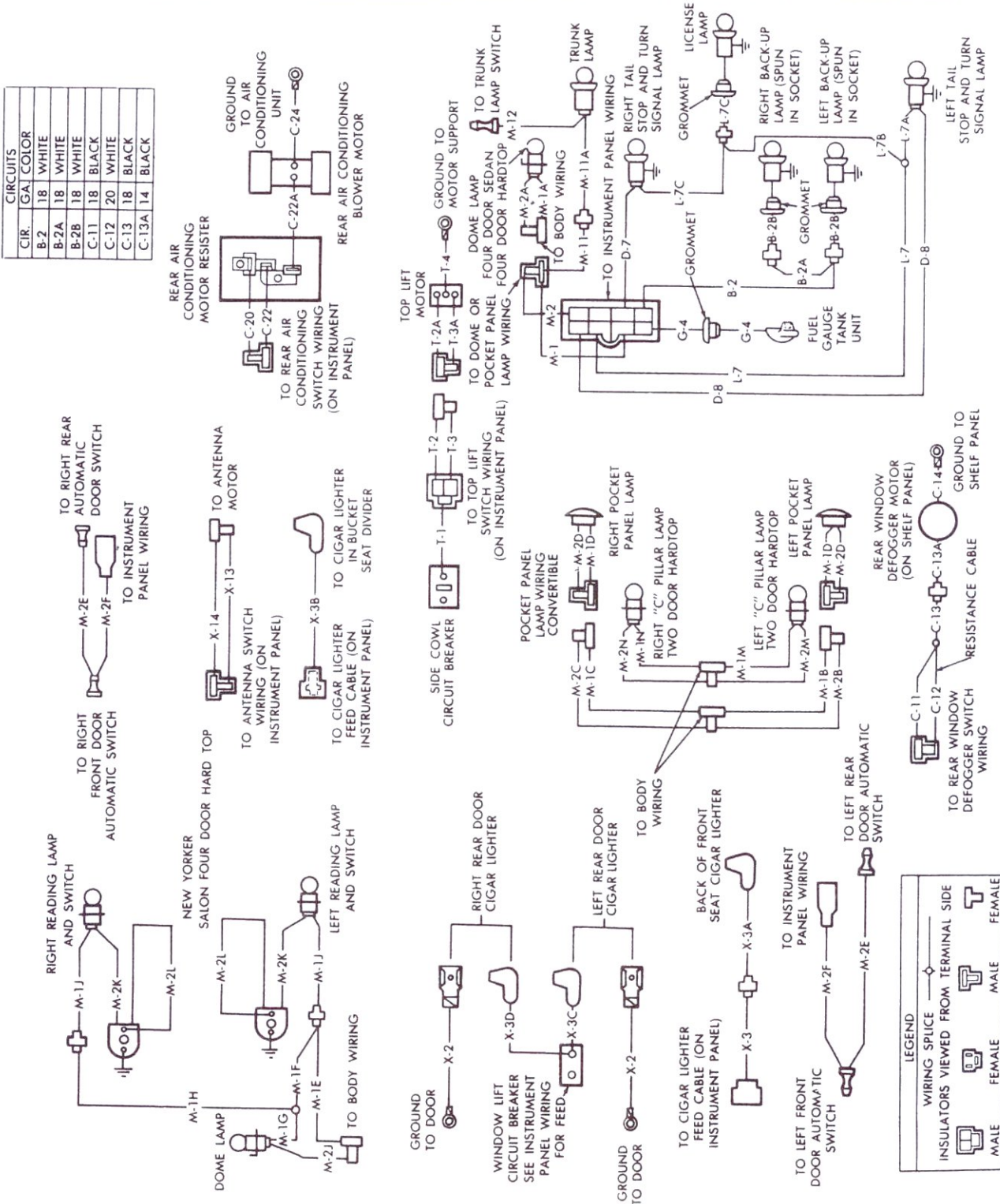

Body Wiring (Except Town and Country) Chrysler

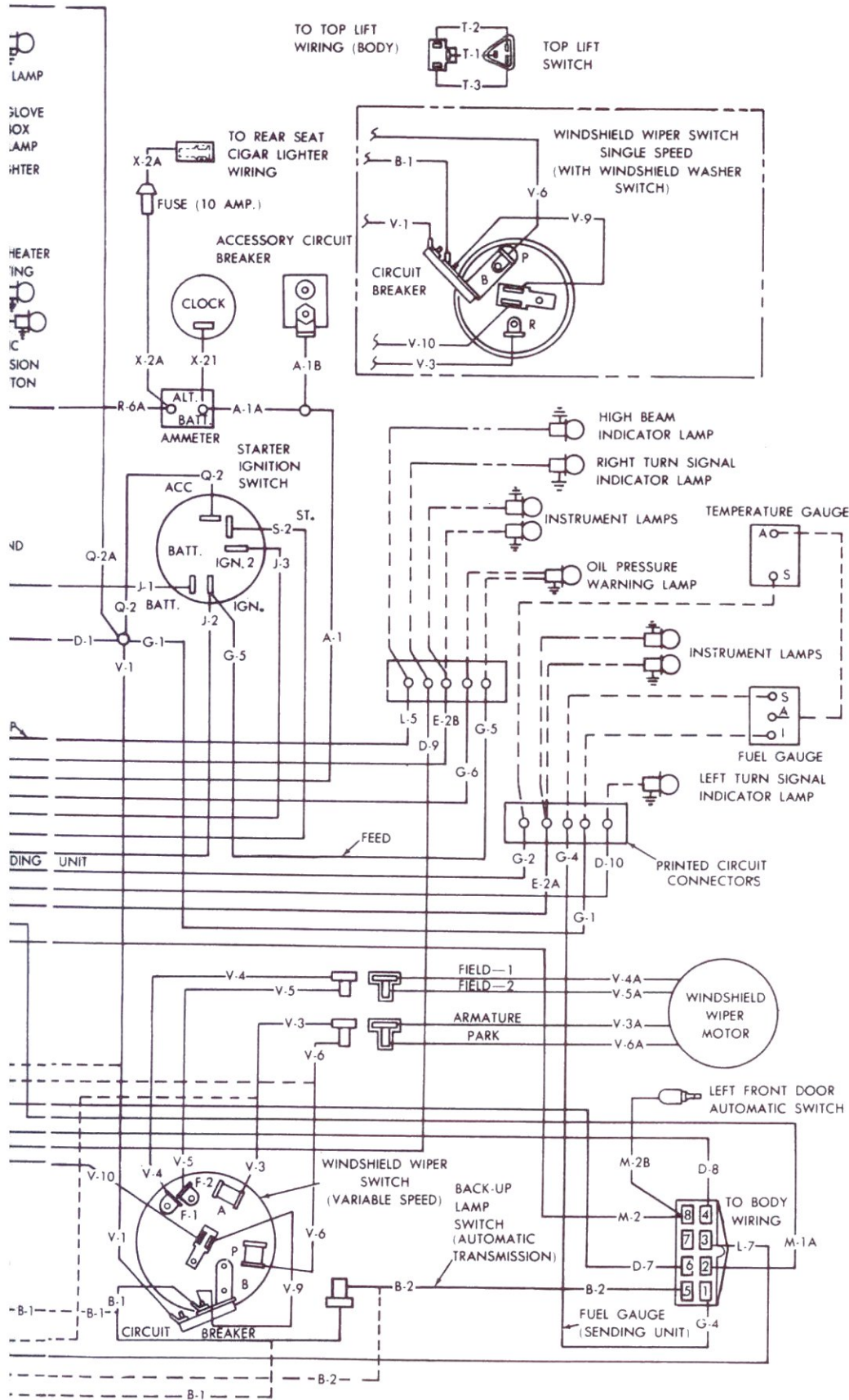

CIRCUITS		
CIR.	GA.	COLOR
A-1	12	RED
A-1A	12	RED
A-1B	12	RED
B-1	18	WHITE
B-1A	18	WHITE
B-2	18	WHITE
B-2A	18	WHITE
C-1	14	BLACK WITH TRACER
C-4	16	BROWN
C-5	16	DARK GREEN
C-10	18	LIGHT GREEN
C-11	18	BLACK
C-12	18	WHITE
D-1	18	BLACK
D-2	18	RED
D-2A	18	RED
D-3	18	PINK
D-4	18	WHITE
D-4A	18	WHITE
D-5	18	TAN
D-5A	18	TAN
D-6	18	LIGHT GREEN
D-6A	18	LIGHT GREEN
D-7	18	BROWN
D-7A	18	BROWN
D-8	18	DARK GREEN
D-8A	18	DARK GREEN
D-9	18	TAN
D-10	18	LIGHT GREEN
E-1	18	TAN
E-2	18	ORANGE
E-2A	18	ORANGE
E-2B	18	ORANGE
E-2C	18	ORANGE
E-2D	18	ORANGE
E-2E	18	ORANGE
E-2F	18	ORANGE
E-2G	18	ORANGE
E-4	18	YELLOW WITH TRACER
E-5	18	ORANGE WITH TRACER
E-5A	18	ORANGE WITH TRACER
F-5B	18	ORANGE WITH TRACER
G-1	18	BLACK
G-2	18	VIOLET
G-4	18	LIGHT BLUE
G-5	18	DARK BLUE
G-6	18	GRAY
H-3	18	BLACK WITH TRACER
H-3A	18	BLACK
J-1	12	RED
J-2	16	DARK BLUE
J-3	18	BROWN
L-1	16	BLACK WITH TRACER
L-2	16	LIGHT GREEN
L-3	16	RED
L-4	16	BLACK
L-5	18	RED

CIRCUITS		
CIR.	GA.	COLOR
L-6	18	YELLOW WITH TRACER
L-7	18	BLACK
L-8	18	PINK
M-1	18	PINK
M-1A	18	PINK
M-2	18	YELLOW
M-2A	18	YELLOW
M-2B	18	YELLOW
M-2C	18	YELLOW
M-2D	18	YELLOW
M-2E	18	YELLOW
M-2F	18	YELLOW
M-2G	18	YELLOW
M-3	18	PINK
M-3A	18	PINK
M-3B	18	PINK
M-4	18	YELLOW
M-5	18	ORANGE
M-5A	18	ORANGE
P-1	18	LIGHT BLUE
P-2	18	LIGHT BLUE
Q-2	12	BLACK
Q-2A	12	BLACK
Q-3	12	RED WITH TRACER
R-6	12	BLACK
R-6A	12	BLACK
S-2	18	YELLOW
T-1	12	RED
T-2	12	BROWN
T-3	12	YELLOW
V-1	16	PINK
V-3	16	BLACK WITH TRACER
V-3A	16	BLACK
V-4	16	RED
V-4A	16	RED
V-5	16	YELLOW
V-5A	16	YELLOW
V-6	16	DARK BLUE
V-6A	16	DARK BLUE
V-9	16	BLACK
V-10	18	TAN WITH TRACER
X-1	16	RED
X-1A	16	RED
X-2	16	RED
X-2A	14	GREEN
X-3	18	BLACK
X-11	18	BLACK
X-11A	18	BLACK
X-12	18	BLACK
X-13	18	BROWN
X-14	18	YELLOW
X-21	18	GRAY
X-24	16	RED
X-24A	16	RED
X-24B	16	RED
X-25	16	RED
X-26	16	LIGHT BLUE
X-27	16	BLACK
X-28	16	BROWN

Instrument Panel Wiring—

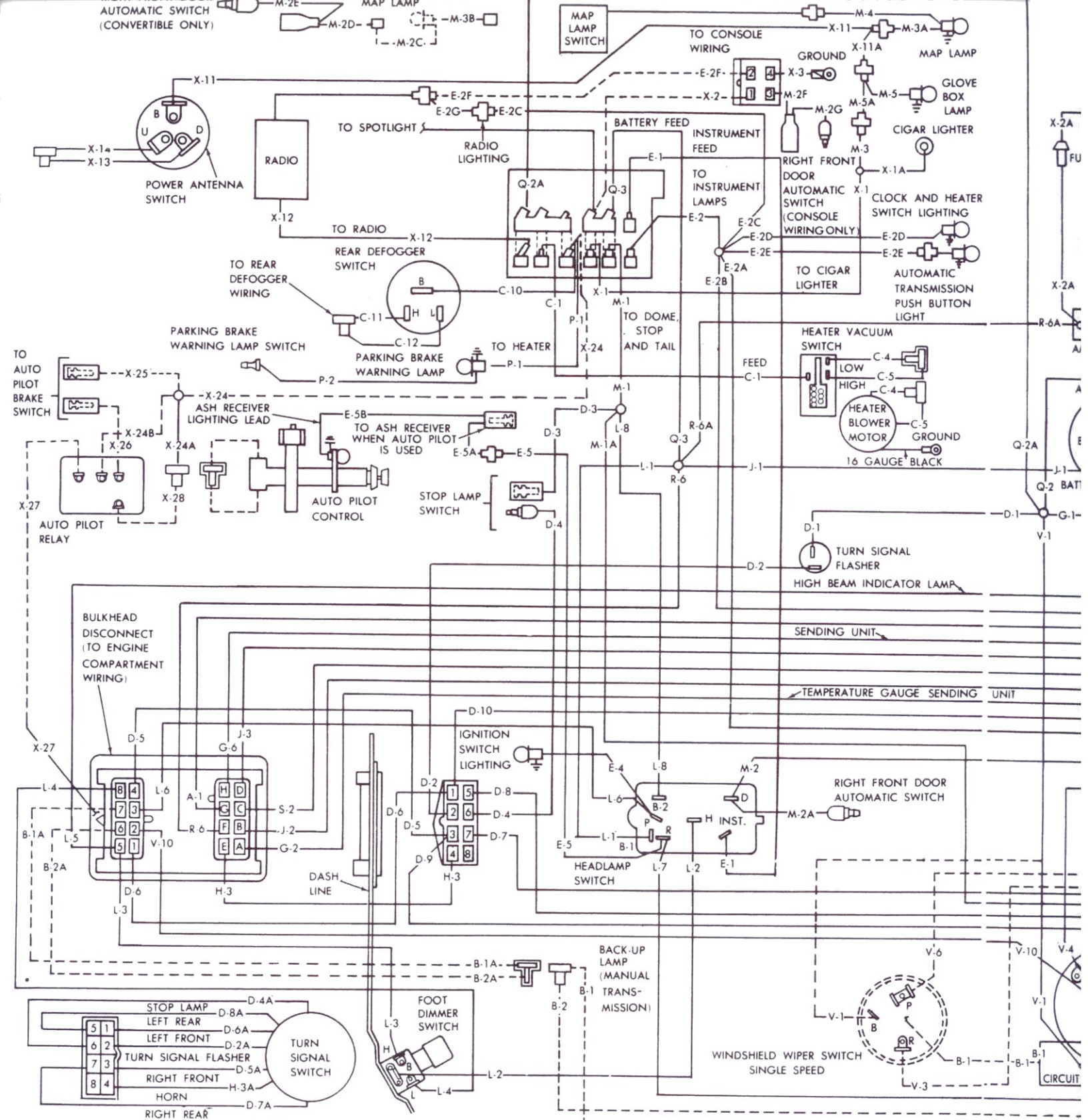

# POWER LOCKS

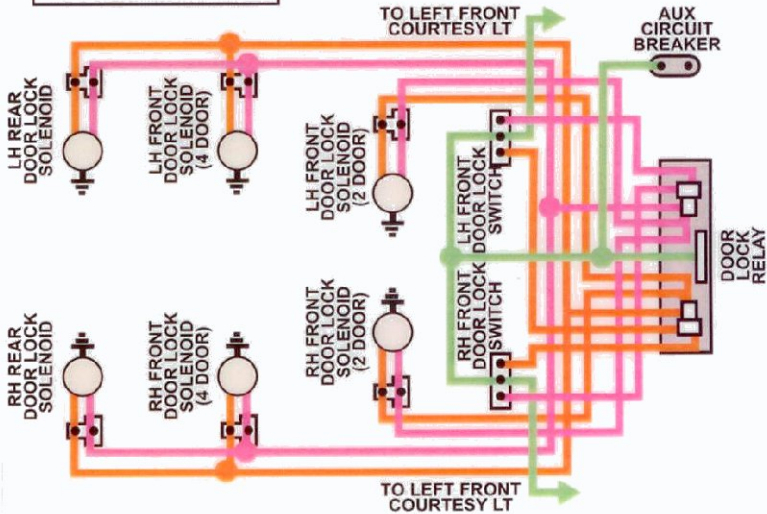

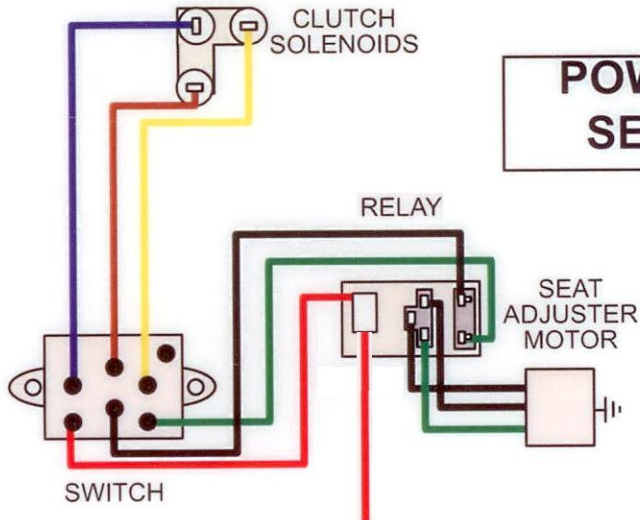

**POWER SEAT**

**12 Volt Supply  
from Circuit Breaker  
Behind Kick Panel**

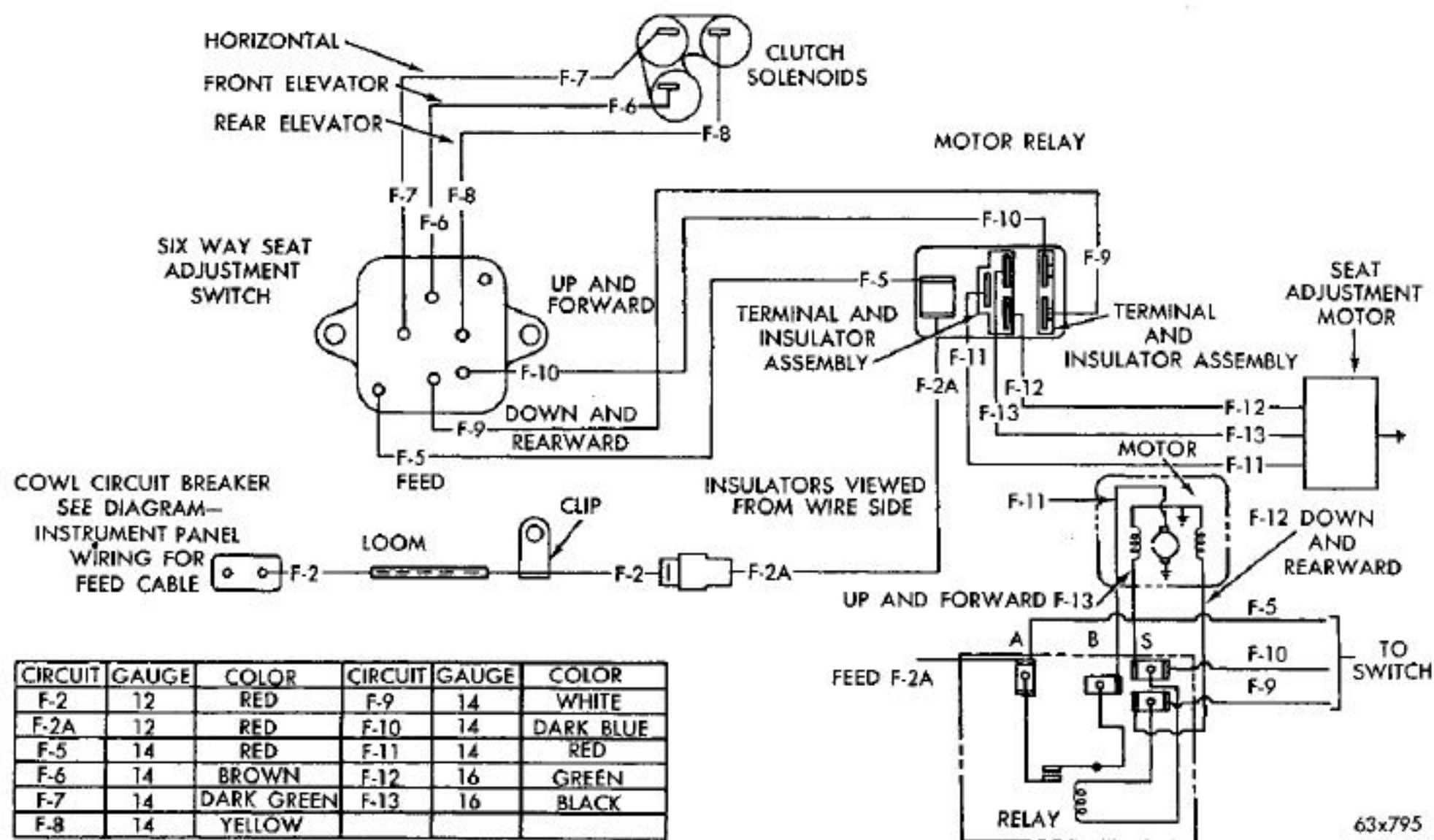
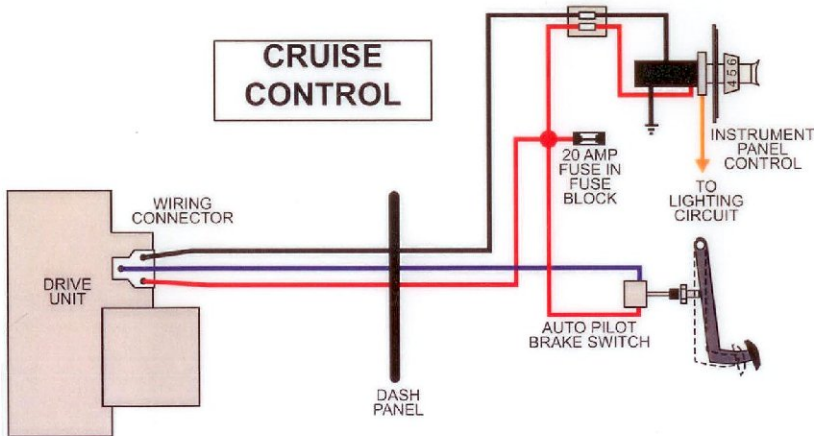
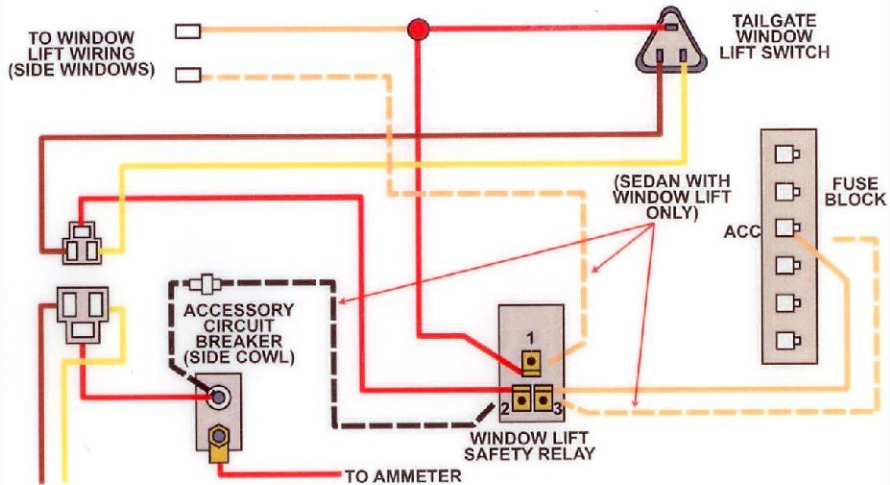

Fig. 138—Six Way Seat Adjusting







**TAIL GATE**

# POWER WINDOWS

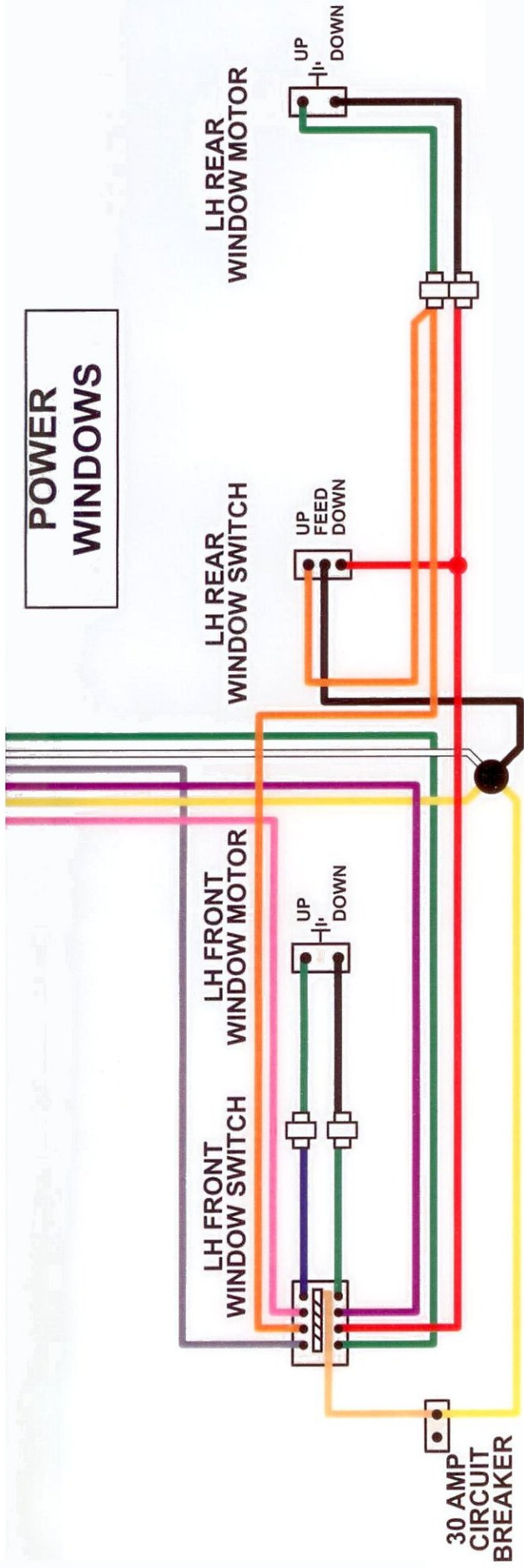

30 AMP  
CIRCUIT  
BREAKER

LH FRONT  
WINDOW SWITCH

LH FRONT  
WINDOW MOTOR

LH REAR  
WINDOW SWITCH

LH REAR  
WINDOW MOTOR

UP  
DOWN

UP  
FEED  
DOWN

UP  
DOWN