

GROUP 22 - WHEELS

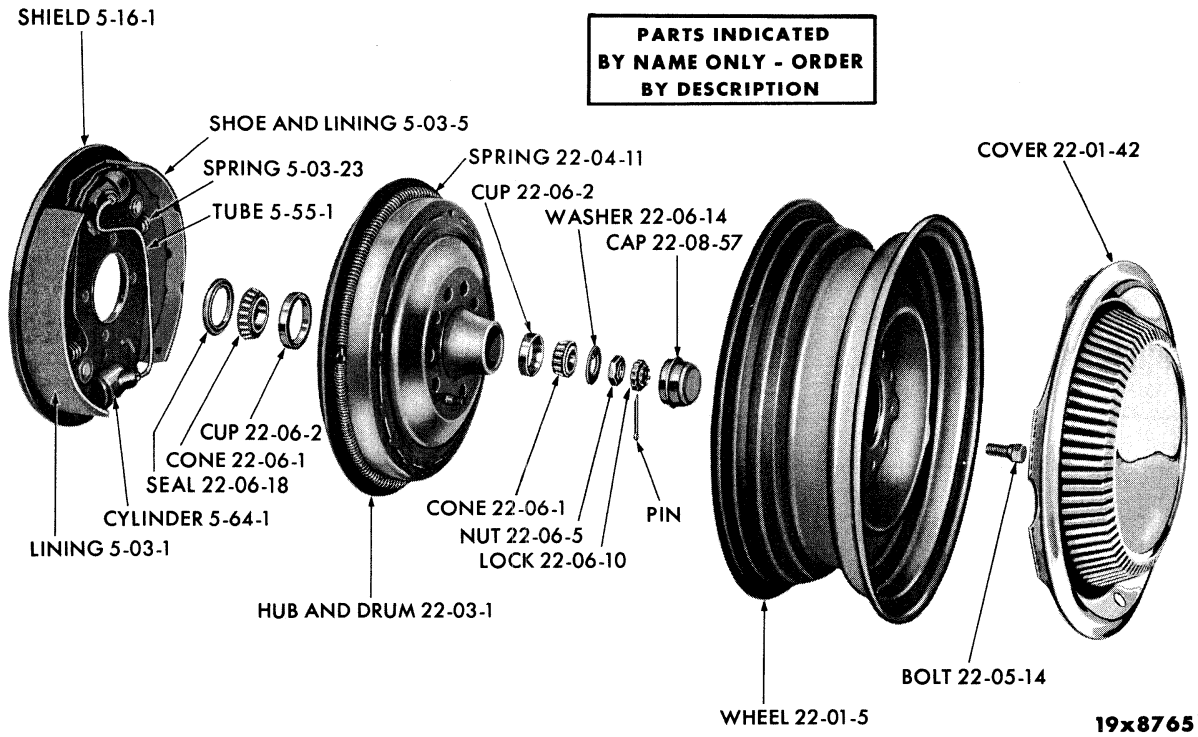

FRONT WHEEL

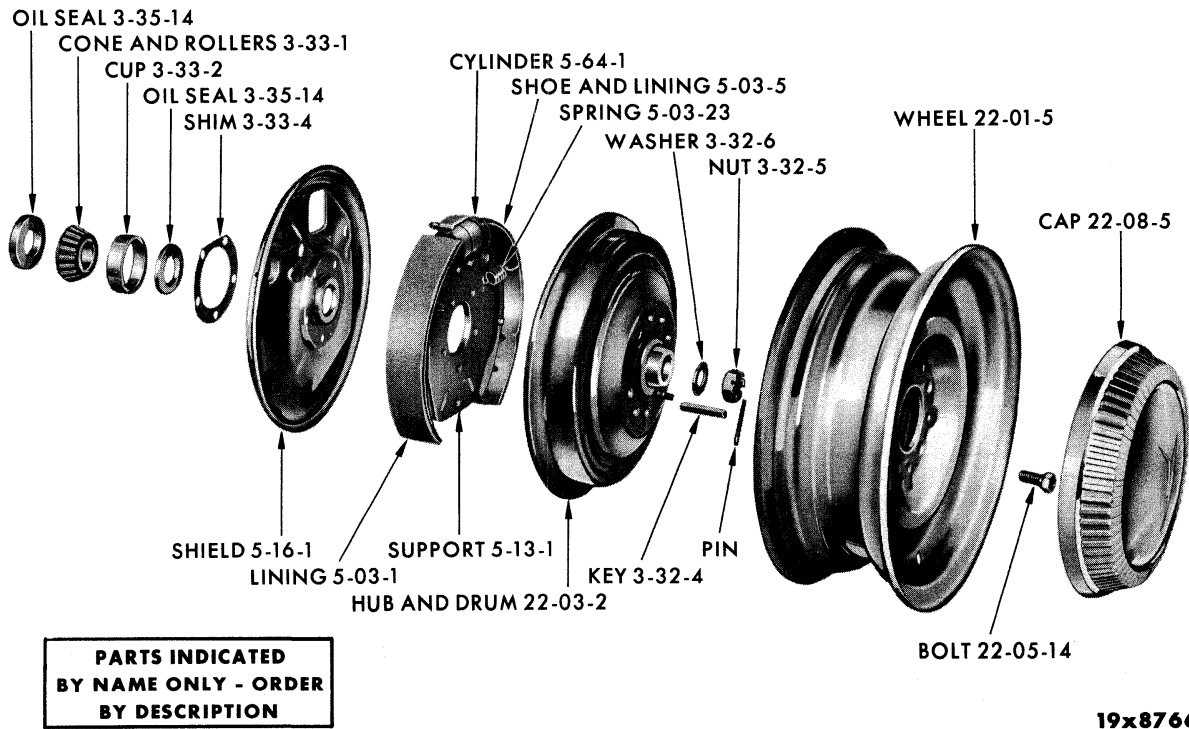

REAR WHEEL

CODE	PART NAME AND DESCRIPTION	NO. OF CYL.	PLYMOUTH	DODGE	DESOTO	CHRYSLER AND IMPERIAL	PER CAR	PART NUMBER
------	---------------------------	-------------	----------	-------	--------	-----------------------	---------	-------------

GROUP 22 - WHEELS

22-01-0 WHEELS

TIRE CHART

Wheel Size	Tire Size
14 x 5.00	7.50 x 14
14 x 5.50	8.00 x 14
14 x 6.00	8.50 x 14
14 x 6.50	9.00 x 14
15 x 5.50	6.70 x 15
15 x 6.00	7.60 x 15
15 x 6.00	8.00 x 15
15 x 6.00	8.20 x 15

22-01-5	WHEEL, 14 x 5.00, PD3, PD4-H	6-8	60	60	-	-	5	2122 448
	15 x 5.50	6-8	60	-	-	-	5	2122 453
	14 x 5.50	6-8	60	-	60	-	5	2084 628
	14 x 5.00, PD4-L 2 D., 4 D., PD4-M 2 D., 4 D., Sp. Cl. Cp.	8	-	60	-	-	5	2122 448
	14 x 5.50, PD1, PD2, PD3, PD4-L 4 D.Sub., Cl.Sed., 4 D., PD4-M Cl.Sed., Sp. Cl. Cp.	6-8	-	60	-	-	5	2084 628
	14 x 6.00, PC1, PC2	6-8	60	60	60	60	5	2122 433
	14 x 6.50, PC1, PC2, PC3	8	-	-	-	60	5	2122 468
	14 x 5.50, PC1	8	-	-	-	60	5	*2084 628
	15 x 6.00, PY1	8	-	-	-	60	5	2122 478
22-01-42	COVER, Wheel, use w/14" Wheel	6-8	60	-	-	-	4	1943 742
	Use w/15" Wheel	6-8	60	-	-	-	4	1637 339
	w/DOME, Spinner Type	6-8	-	60	-	-	4	*2122 534
	w/o Dome	6-8	-	60	-	-	4	*1940 831
	PC1, PC2, PC3	8	-	-	60	-	4	1940 830
	PC3-300	8	-	-	-	60	4	2122 530
	PY1-L, PY1-M, 15" Wheel	8	-	-	-	60	4	*2122 537
	PY1-H, 15" Wheel	8	-	-	-	60	4	*2122 540
22-01-43	MEDALLION, Wheel Cover, PC3-300	8	-	-	-	60	4	1856 423
	PY1	8	-	-	-	60	4	2122 542
	LUG, Spinner Type	6-8	-	60	-	-	16	*2122 536
	PY1	8	-	-	-	60	★	2122 539
22-01-51	DOME, Wheel Cover, PC3-300	8	-	-	-	60	4	1829 639
22-01-53	RETAINER, Wheel Cover Name Plate and Medallion, PY1-H	8	-	-	-	60	4	2122 543

22-03-0 HUB AND BRAKE DRUM

22-03-1	HUB and DRUM, Front Right, 11" x 2"							
	Brakes, except Sub.	6-8	60	-	-	-	1	*2200 130
	Left, 11" x 2" Brakes, except Sub.	6-8	60	-	-	-	1	*2200 131
	Right, 11" x 2" Brakes, PD3, PD4, except Sub.	6-8	-	60	-	-	1	*2122 206
	Left, 11" x 2" Brakes, PD3, PD4, except Sub.	6-8	-	60	-	-	1	*2122 207
	Right, 11" x 2 1/2" Brakes, PP1, PP2, Sub., except Cal. Blt., PD3, PD4, Sub., PD1, PD2, PD3, Taxi, PD4 Taxi	6-8	60	60	-	-	1	2200 132
	Left, 11" x 2 1/2" Brakes, PP1, PP2, Sub., except Cal. Blt., PD3, PD4, Sub., PD1, PD2, PD3 Taxi, PD4 Taxi	6-8	60	60	-	-	1	2200 133

★ Indicates use as required. Numerals in parentheses () refer to notes. Printed in U.S.A.
 ☐ Indicates parts not listed in any previous parts book. Prices and specifications subject to change without notice.
 * Indicates change or addition. Page 22-3 Dec. 9, 1960 Supersedes April 20, 1960.

1960 PASSENGER CAR PARTS CATALOG

WHEELS

CODE	PART NAME AND DESCRIPTION	NO. OF CYL.	PLYMOUTH	DODGE	DESOTO	CHRYSLER AND IMPERIAL	PER CAR	PART NUMBER
22-03-0 HUB AND BRAKE DRUM - Cont'd								
22-03-1	HUB and DRUM - Cont'd							
	Right, 11" x 2 1/2" brake, PP1, PP2, Sub., Cal. Blt.	6-8	60	-	-	-	1	1948 112
	Left, 11" x 2 1/2" Brake, PP1, PP2, Sub., Cal. Blt.	6-8	60	-	-	-	1	1948 113
	Right, 11" x 2 1/2" Brake, PD3-L, PD4, Sub., PD1, PD2, PD4-D500, PC1 except Sub. . . .	6-8	-	60	60	60	1	1948 112
	Left, 11" x 2 1/2" Brake, PD3-L, PD4, Sub., PD1, PD2, PD4-D500, PC1 except Sub. . . .	6-8	-	60	60	60	1	1948 113
	Right, 12" x 2 1/2" Brake, PC1, PC2, PC3 . .	6-8	60	60	60	60	1	2084 798
	Left, 12" x 2 1/2" Brake, PC1, PC2, PC3 . .	6-8	60	60	60	60	1	2084 799
	Right, 12" x 2 1/2" Brake, PY1	8	-	-	-	60	1	1732 294
	Left, 12" x 2 1/2" Brake, PY1	8	-	-	-	60	1	1732 295
22-03-2	HUB and DRUM, Rear Right, 11" x 2" Brake.	6-8	60	-	-	-	1	2200 134
	Left, 11" x 2" Brake	6-8	60	-	-	-	1	2200 135
	Right, 11" x 2" Brake, PD3, PD4, except Det. Blt.	6-8	-	60	-	-	1	2200 134
	Left, 11" x 2" Brake, PD3, PD4, except Det. Blt.	6-8	-	60	-	-	1	2200 135
	Right, 11" x 2" Brake, PD3, PD4, Det. Blt. .	6-8	-	60	-	-	1	1734 162
	Left, 11" x 2" Brake, PD3, PD4, Det. Blt. . .	6-8	-	60	-	-	1	1734 163
	Right, 11" x 2 1/2" Brake, PD1, PD2, PD3, Taxi, PD4, PD4-D500, PC1 except Sub. . . .	6-8	-	60	60	60	1	1730 826
	Left, 11" x 2 1/2" Brake, PD1, PD2, PD3 Taxi, PD4, PD4-500, PC1 except Sub.	6-8	-	60	60	60	1	1730 827
	Right, 12" x 2 1/2" Brake, PC1, PC2, PC3 . .	6-8	60	60	60	60	1	1732 512
	Left, 12" x 2 1/2" Brake, PC1, PC2, PC3 . .	6-8	60	60	60	60	1	1732 513
	Right, 12" x 2 1/2" Brake, PY1	8	-	-	-	60	1	1732 296
	Left, 12" x 2 1/2" Brake, PY1	8	-	-	-	60	1	1732 297
22-04-0 WHEEL BRAKE DRUM								
22-04-11	SPRING, Dampener w/379 Coils, 35 3/16" lgh.	6-8	60	60	60	60	★	1142 258
	w/344 Coils, 32" lgh.	6-8	60	60	60	60	★	1142 259
22-05-0 WHEEL HUB								
22-05-14	STUD, 11" Brakes, Right, Front and Rear except Sub., Std.	6-8	60	-	-	-	10	679 118
	Left	6-8	60	-	-	-	10	679 119
	.030 O/S, Right, Front and Rear, except Sub. .	6-8	60	-	-	-	10	687 901
	Left	6-8	60	-	-	-	10	687 902
	Right, Front, Sub., Std.	6-8	60	-	-	-	5	1948 116
	Left	6-8	60	-	-	-	5	1948 117
	Right, Rear, Sub., Std.	6-8	60	-	-	-	5	679 118
	Left	6-8	60	-	-	-	5	679 119
	Right, Rear, Sub., .030 O/S	6-8	60	-	-	-	5	687 901
	Left	6-8	60	-	-	-	5	687 902
	Right, Front, PC1 except Sub., Std.	6-8	-	60	60	60	5	1948 116
	Left	6-8	-	60	60	60	5	1948 117
	Right, Rear, PC1 except Sub., Std.	6-8	-	60	60	60	5	679 118
	Left	6-8	-	60	60	60	5	679 119
	Right, Rear, PC1 except Sub., .030 O/S . . .	6-8	-	60	60	60	5	687 901
	Left	6-8	-	60	60	60	5	687 902
	Right, Front and Rear, PC1 Sub., Std.	8	-	-	-	60	10	679 118
	Left	8	-	-	-	60	10	679 119
	Right, Front and Rear, PC1 Sub., .030 O/S . .	8	-	-	-	60	10	687 901
	Left	8	-	-	-	60	10	687 902
	Right, Front, Sub., .030 O/S	6-8	60	-	-	-	5	2122 208
	Left	6-8	60	-	-	-	5	2122 209
	Right, Front, PC1 except Sub., .030 O/S . . .	6-8	-	60	60	60	5	2122 208
	Left	6-8	-	60	60	60	5	2122 209

★ Indicates use as required.

Numerals in parentheses () refer to notes.

Printed in U.S.A.

☐ Indicates parts not listed in any previous parts book.

Prices and specifications subject to change without notice.

Dec. 9, 1960 Supersedes April 20, 1960.

* Indicates change or addition.

CODE	PART NAME AND DESCRIPTION	NO. OF CYL.	PLYMOUTH	DODGE	DESOTO	CHRYSLER AND IMPERIAL	PER CAR	PART NUMBER
22-05-0 WHEEL HUB - Cont'd								
22-05-14	STUD - Cont'd							
	12" Brakes, Right, Front and Rear, PC1							
	Sub., PC2, PC3	6-8	60	60	60	60	10	1633 050
	Left	6-8	60	60	60	60	10	1633 051
	Right, Front and Rear, PY1	8	-	-	-	60	10	1633 052
	Left	8	-	-	-	60	10	1633 053
22-05-24	NUT, Right, PC1, PC2, PC3	6-8	60	60	60	60	10	1139 316
	Left, PC1, PC2, PC3	6-8	60	60	60	60	10	1139 317
	Right, PY1	8	-	-	-	60	10	1315 697
	Left, PY1	8	-	-	-	60	10	1315 698
22-06-0 FRONT WHEEL BEARINGS								
22-06-1	CONE and ROLLER, Inner, PC1, PC2, PC3 .	6-8	60	60	60	60	2	1619 701
	Outer, PC1, PC2, PC3	6-8	60	60	60	60	2	1619 703
	Inner, PY1	8	-	-	-	60	2	1789 755
	Outer, PY1	8	-	-	-	60	2	1790 241
22-06-2	CUP, Inner, PC1, PC2, PC3	6-8	60	60	60	60	2	1619 700
	Outer, PC1, PC2, PC3	6-8	60	60	60	60	2	1619 702
	Inner, PY1	8	-	-	-	60	2	1789 754
	Outer, PY1	8	-	-	-	60	2	1790 244
22-06-5	NUT	6-8	60	60	60	60	2	1732 300
22-06-10	LOCK, Bearing Nut	6-8	60	60	60	60	2	1673 324
22-06-14	WASHER	6-8	60	60	60	60	2	600 194
22-06-18	SEAL, Dust, PC1, PC2, PC3	6-8	60	60	60	60	2	1613 409
	PY1	8	-	-	-	60	2	1671 340
22-08-0 WHEEL HUB CAPS								
22-08-5	CAP, Wheel Hub	6-8	60	-	-	-	4	1943 743
		6-8	-	60	-	-	4	1948 163
	15 inch.	6-8	-	60	-	-	4	1637 342
	PS1	8	-	-	60	-	4	1732 338
	PC1	8	-	-	-	60	4	1736 676
22-08-57	CAP, Front Wheel Hub Grease, PC1, PC2, PC3	6-8	60	60	60	60	2	1613 416
	PY1	8	-	-	-	60	2	1671 341
22-09-0 WHEEL BALANCE WEIGHT								
22-09-1	WEIGHT, 1/2 oz.	6-8	60	60	60	60	★	1615 349
	1 oz.	6-8	60	60	60	60	★	1615 350
	1 1/2 oz.	6-8	60	60	60	60	★	1615 351
	2 oz.	6-8	60	60	60	60	★	1615 352
	2 1/2 oz.	6-8	60	60	60	60	★	1615 353
	3 oz.	6-8	60	60	60	60	★	1615 354
NOTE: The following are used with full Wheel Cover and extended Rim Flange.								
	WEIGHT, 1/2 oz.	6-8	-	60	60	-	★	1940 813
	1 oz.	6-8	-	60	60	-	★	1940 814
	1 1/2 oz.	6-8	-	60	60	-	★	1940 815
	2 oz.	6-8	-	60	60	-	★	1940 816
	2 1/2 oz.	6-8	-	60	60	-	★	1940 817
	3 oz.	6-8	-	60	60	-	★	1940 818
22-20-0 SPARE WHEEL CARRIER								
22-20-80	PLATE, Spare Wheel Anchor, PY1	8	-	-	-	60	1	1750 747
22-20-87	ROD, Spare Wheel Anchor, Sub., 2-Seater . .	6-8	60	60	-	-	1	1963 237
	Sub., 3-Seater	6-8	60	60	-	60	1	1963 236
	Except Cv. Cp.	6-8	-	60	-	-	1	1963 236
	PY1	8	-	-	-	60	1	*1963 237
22-20-89	NUT, Spare Wheel Anchor Rod Wing	6-8	60	60	60	60	1	6000 332

★ Indicates use as required.

Numerals in parentheses () refer to notes.

Printed in U.S.A.

☐ Indicates parts not listed in any previous parts book.

Prices and specifications subject to change without notice.

* Indicates change or addition.

