

GROUP 22 - WHEELS

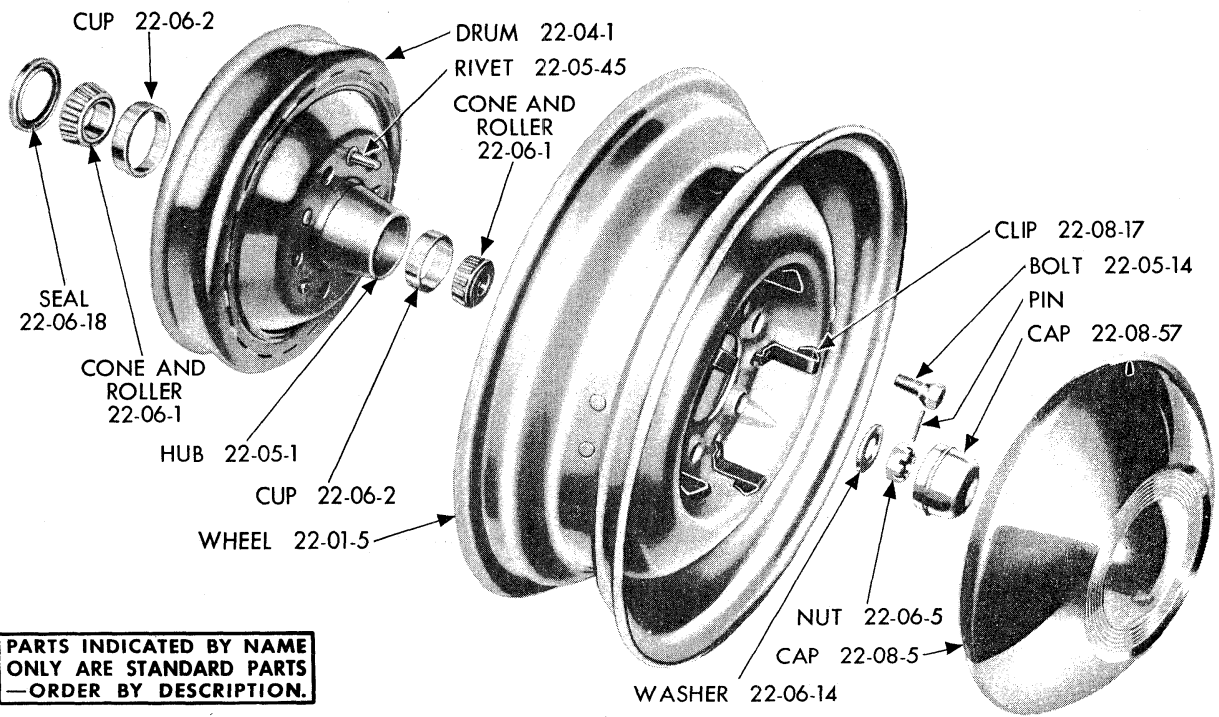

**PARTS INDICATED BY NAME ONLY ARE STANDARD PARTS —ORDER BY DESCRIPTION.**

19x6719

Plate 22-1

FRONT WHEEL

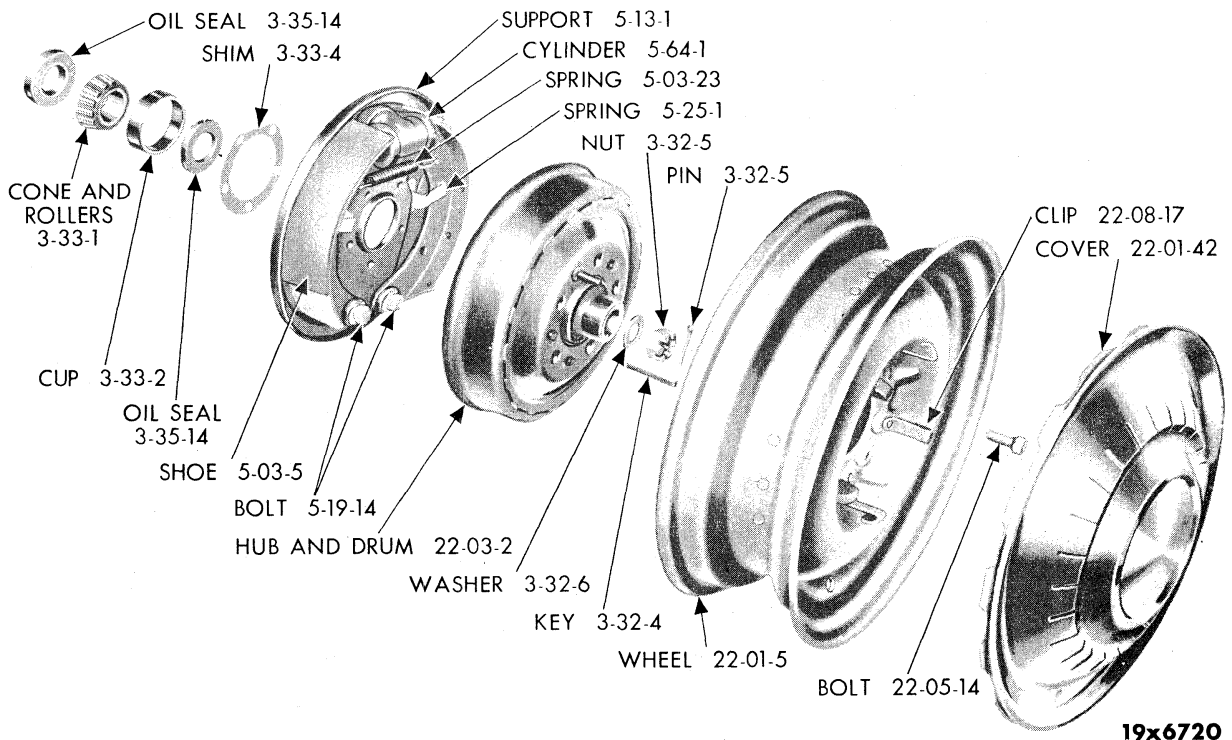

19x6720

Plate 22-2

REAR WHEEL



CODE	PART NAME AND DESCRIPTION	NO. OF CYL.	PLYMOUTH	DODGE	DESOTO	CHRYSLER AND IMPERIAL	PER CAR	PART NUMBER
------	---------------------------	-------------	----------	-------	--------	-----------------------	---------	-------------

**22-01-0 WHEELS**

TIRE CHART

Wheel Size	Tire Size
14 x 5.00	7.50 x 14
14 x 5.50	8.00 x 14
14 x 6.00	8.50 x 14
14 x 6.50	9.00 x 14
14 x 7.00	9.50 x 14
15 x 4.50	6.70 x 15
15 x 5.00	7.10 x 15
15 x 5.50	7.60 x 15
15 x 5.50	8.00 x 15
15 x 6.00	7.60 x 15
15 x 6.00	8.00 x 15
15 x 6.00	8.20 x 15
15 x 6.50	8.90 x 15

22-01-5	WHEEL, 15 x 4.50, w/10" Brake . . . . .	6-8	55-56	-	-	-	5	1554 987
	15 x 5.00, w/11" Brake . . . . .	6-8	55-56	-	-	-	5	1615 366
	15 x 5.50, P29 Fury, D63 w/12" Brake, All C67, C68, C71 except Cal. Blt., C72 except Cal. Blt., except Est. Wgn., C68-300 All . . . . .	8	53	56	-	55-56	5	1635 360
	14 x 5.00 . . . . .	6-8	57-58	58	-	-	5	1739 137
	14 x 5.50, LS1, LC1 . . . . .	6-8	57-58	58	58	58	5	1670 809
	14 x 6.00 . . . . .	6-8	57-58	58	-	-	5	1736 689
	15 x 4.50, UP TO . . . . .	6	-	55-56 (1)	-	-	5	1316 710
	15 x 5.00 . . . . .	8	-	55-56	-	-	5	1270 660
	15 x 4.50, Calif. Blt. Only . . . . .	6	-	55-56	-	-	5	1320 042
	15 x 4.50, AFTER . . . . .	6	-	56 (1)	-	-	5	1661 937
	14 x 5.50, D66 Cv. Cp., D67, D70, D71, S27 . . . . .	6-8	-	57	57	-	5	1670 809
	14 x 5.00, D66 except Cv. Cp., D72 . . . . .	6-8	-	57	-	-	5	1739 137
	14 x 6.00, w/12" Brakes, D66, D72, LD1, LD2-L . . . . .	6-8	-	57-58	-	-	5	1736 689
	15 x 5.50, S21, S24, All, S22, S23, C67, C68, C71 Cal. Blt., C72 Cal. Blt., except Est. Wgn. . . . .	8	-	-	55-56	55-56	5	1319 670
	15 x 6.00, S22, C67, C68, Est. Wgn., C69 All . . . . .	8	-	-	55	55	5	1136 619
	15 x 6.00, S23, C71, C72, Est. Wgn., C73 All . . . . .	8	-	-	56	56	5	1633 066
	14 x 6.00, C75, LC1, LC2 . . . . .	8	-	-	57-58	57-58	5	*1736 689
	15 x 6.00, C70 . . . . .	8	-	-	-	55	5	1329 135
	15 x 6.00, C70 . . . . .	8	-	-	-	56	5	1633 073
	15 x 6.00, C72 AFTER N56-2934, except Est. Wgn. . . . .	8	-	-	-	56	5	1674 194
	14 x 6.50, S26 Sub., C76, LC1, LC2, LC3 . . . . .	8	-	-	57	57-58	5	*1730 809
	14 x 7.00, IM, LY1 . . . . .	8	-	-	-	57-58	5	1730 814
	WHEEL, Wire, 15 x 5.00, Chrome . . . . .	6-8	-	55	-	-	5	1533 279
	15 x 5.50, C67, C68, C71, C72, except Est. Wgn. . . . .	8	-	-	-	55-56	5	*1534 619
	15 x 6.50, C67, C68, Est. Wgn., C69, C70, All . . . . .	8	-	-	-	55	5	1533 281
22-01-37	SPOKE, Short, Chrome, 3" lgh. . . . .	6-8	-	55	-	55	★	1537 793
	Long, except Est. Wgn., 3 1/8" lgh. . . . .	6-8	-	55	-	55-56	120	1537 794
	Short, 1 15/16" lgh., C71, C72, except Est. Wgn. . . . .	8	-	-	-	55-56	★	1537 792
22-01-38	NIPPLE, C71, C72, except Est. Wgn. . . . .	6-8	-	55	-	55-56	★	1401 936
22-01-42	COVER, Stainless Steel . . . . .	6-8	55	-	-	-	4	1554 990
	Wire Wheel . . . . .	6-8	55	-	-	-	4	1554 975
	Stainless Steel . . . . .	6-8	56	-	-	-	4	1637 339
	P29 Fury . . . . .	8	56	-	-	-	4	1732 509
	P31 Fury . . . . .	6-8	57	-	-	-	4	1730 797
	P31 Fury . . . . .	8	57	-	-	-	4	1820 253
	P31 Fury . . . . .	6-8	58	-	-	-	4	1828 404
	LP2 Fury . . . . .	8	58	-	-	-	4	1828 602
	Stainless Steel . . . . .	6	-	55	-	-	4	1559 668
	Stainless Steel . . . . .	8	-	55	-	-	4	1559 669
	Chrome . . . . .	6-8	-	55-56	-	-	4	1619 683
	Stainless Steel . . . . .	8	-	56	-	-	4	1637 338

NOTE 1: D62 Ser. No. 32231744 except Cover, Ser. No. 32230483 w/Cover.

# 1955-58 PASSENGER CAR PARTS LIST

WHEELS

CODE	PART NAME AND DESCRIPTION	NO. OF CYL.	PLYMOUTH	DODGE	DESOTO	CHRYSLER AND IMPERIAL	PER CAR	PART NUMBER
	w/DOME . . . . .	6-8	-	57	-	-	4	1734 208
	w/o Dome . . . . .	6-8	-	57	-	-	4	1732 320
	w/DOME . . . . .	6-8	-	58	-	-	4	1828 604
	w/o Dome . . . . .	6-8	-	58	-	-	4	1828 398
	Stainless Steel . . . . .	8	-	-	55	-	4	1559 666
	Stainless Steel . . . . .	8	-	-	56	-	4	1637 343
	S24 Adventurer . . . . .	8	-	-	56	-	4	1732 334
	S26, Sp.Cl.Cp., Cv. Cp., Adventurer . . . . .	8	-	-	57	-	4	1820 254
	Stainless Steel . . . . .	8	-	-	57	-	4	1734 185
	Stainless Steel . . . . .	8	-	-	58	-	4	1828 402
	LS3 Adventurer . . . . .	8	-	-	58	-	4	1828 600
	Wire Spoke Type, C67, C68, except Est. Wgn. . . . .	8	-	-	-	55	4	1554 977
	Stainless Steel, C67 . . . . .	8	-	-	-	55	4	1559 665
	Stainless Steel, C68 . . . . .	8	-	-	-	55	4	1559 672
	Stainless Steel, C68-300, C72-300 . . . . .	8	-	-	-	55-56	4	1638 419
	Stainless Steel, C69 . . . . .	8	-	-	-	55	4	1613 397
	C70 . . . . .	8	-	-	-	55	4	1559 676
	C70 . . . . .	8	-	-	-	56	4	1637 340
	Stainless Steel, C71, C72, 3 Ribbed . . . . .	8	-	-	-	56	4	1674 214
	C71, C72 . . . . .	8	-	-	-	56	4	1635 352
	C73 . . . . .	8	-	-	-	56	4	1613 397
	Stainless Steel, C75 . . . . .	8	-	-	-	57	4	1734 182
	Stainless Steel, C76 . . . . .	8	-	-	-	57	4	1736 656
	C76-300 . . . . .	8	-	-	-	57	4	1820 256
	Stainless Steel, IM 1-1 . . . . .	8	-	-	-	57	4	1736 681
	IM 1-2, IM 1 Cv.Cp. . . . .	8	-	-	-	57	4	1736 675
	IM 1-4 . . . . .	8	-	-	-	57	4	1736 680
	LC1, LC2 . . . . .	8	-	-	-	58	4	1828 406
	LC3 . . . . .	8	-	-	-	58	4	1828 408
	LC3-300 . . . . .	8	-	-	-	58	4	1828 413
	LY1-L . . . . .	8	-	-	-	58	4	1736 581
	LY1-M . . . . .	8	-	-	-	58	4	1828 409
	LY1-H . . . . .	8	-	-	-	58	4	1828 411
22-01-43	MEDALLION, Cover, C68-300, C72-300 . . . . .	8	-	-	-	55-56	4	1638 418
	C68, C72 AFTER N56-15490 . . . . .	8	-	-	-	55-56	4	1559 675
	C72 from N56-8700 to N56-15490 . . . . .	8	-	-	-	56	4	1638 439
	C69, C70, C73 . . . . .	8	-	-	-	55-56	4	1559 670
	C71 . . . . .	8	-	-	-	56	4	1674 216
	LS3 Adventurer . . . . .	8	-	-	58	-	4	1829 111
	LC3-300 . . . . .	8	-	-	-	58	4	1828 420
	LY1-M, LY1-H . . . . .	8	-	-	-	58	4	1828 414
	Lug, IM, LC3-300 . . . . .	8	-	-	-	57-58	12	*1732 327
22-01-44	PALNUT, Wheel Cover Med., LS3 Adventurer . . . . .	8	-	-	58	-	8	⊠1850 889
22-01-46	EXTENSION, Tire Valve, w/o Hose, S22 Est. Wgn., C67, C68, All . . . . .	6-8	55	-	55	55	4	1489 091
	w/HOSE, C69, C68-300, C72-300, C73 . . . . .	8	-	-	-	55-56	4	1613 399
	w/HOSE, C70 . . . . .	8	-	-	-	55-56	4	1615 355
22-01-47	SCREW and LOCKWASHER, Wheel Cover Dome, LC3-300, LY1 . . . . .	8	-	-	-	58	12	1829 632
22-01-48	CAP, Wire Wheel Cover . . . . .	6-8	55	-	-	-	4	1615 356
	C67, C68, C69 . . . . .	8	-	-	-	55	4	1559 678
	C71, C72 . . . . .	8	-	-	-	56	4	1674 215
	DOME, Wheel Cover, LS3 Adventurer . . . . .	8	-	-	58	-	4	1674 215
22-01-49	CLIP, Cover, P29 Fury, S24 Adventurer . . . . .	8	56	-	56	-	20	1732 336
	C71, C72, LS3 Adventurer . . . . .	8	-	-	58	57	4	1674 217
	RETAINER, Wheel Cover Medallion, LC3-300, LY1-M, LY1-H . . . . .	8	-	-	-	58	4	1829 625
22-01-50	BUMPER, Cover, P29 Fury, S24 Adventurer. . . . .	8	56	-	56	-	20	1732 335
22-01-51	DOME, Wheel Cover, LY1-L . . . . .	8	-	-	-	58	4	1829 626
	LC3-300, LY1-M, LY1-H . . . . .	8	-	-	-	58	4	1829 624
<b>22-03-0</b>	<b>HUB AND BRAKE DRUM</b>							
22-03-1	HUB and DRUM, Front							
	Right, 10" Brake UP TO . . . . .	6	55 (1)	-	-	-	1	1483 000
	Left, 10" Brake, UP TO . . . . .	6	55 (1)	-	-	-	1	1483 001
	Right, 10" Brake, AFTER . . . . .	6	55-56 (1)	-	-	-	1	1615 328
	Left, 10" Brake, AFTER . . . . .	6	55-56 (1)	-	-	-	1	1615 329

NOTE 1: P26 Approximate Serial No. 13842484

CODE	PART NAME AND DESCRIPTION	NO. OF CYL.	PLYMOUTH	DODGE	DESOTO	CHRYSLER AND IMPERIAL	PER CAR	PART NUMBER
	Right, 11" Brake . . . . .	6-8	55-56	-	-	-	1	1638 424
	Left, 11" Brake . . . . .	6-8	55-56	-	-	-	1	1638 425
	Right . . . . .	6-8	57-58	-	-	-	1	1732 328
	Left . . . . .	6-8	57-58	-	-	-	1	1732 329
	Right . . . . .	6-8	-	55-56	-	-	1	1615 326
	Left . . . . .	6-8	-	55-56	-	-	1	1615 327
	Right, D63 w/12" Brake . . . . .	8	-	56	-	-	1	1635 354
	Left, D63 w/12" Brake . . . . .	8	-	56	-	-	1	1635 355
	Right, D63-D500 . . . . .	8	-	56	-	-	1	1637 326
	Left, D63-D500 . . . . .	8	-	56	-	-	1	1637 327
	Right, 11" Brake, S27, LS1, LC1 except Sub. . . . .	6-8	-	57-58	57-58	58	1	*1730 824
	Left, 11" Brake, S27, LS1, LC1 except Sub. . . . .	6-8	-	57-58	57-58	58	1	*1730 825
	Right, 12" Brake, LP2, S27, LS1, LC1, LC2, LC3 . . . . .	6-8	58	57-58	57-58	58	1	1732 288
	Left, 12" Brake, LP2, S27, LS1, LC1, LC2, LC3 . . . . .	6-8	58	57-58	57-58	58	1	1732 289
	Right, S21 All, S22 except Est. Wgn., UP TO . . . . .	8	-	-	55 (2)	-	1	1401 948
	Left, S21 All, S22 except Est. Wgn., UP TO . . . . .	8	-	-	55 (2)	-	1	1401 949
	Right, S21 All, S22 except Est. Wgn., AFTER . . . . .	8	-	-	55 (2)	-	1	1615 332
	Left, S21 All, S22 except Est. Wgn., AFTER . . . . .	8	-	-	55 (2)	-	1	1615 333
	Right, S22, C67, C68, Est. Wgn., C69 All, UP TO . . . . .	8	-	-	55	55 (5)	1	1312 857
	Left, S22, C67, C68, Est. Wgn., C69 All, UP TO . . . . .	8	-	-	55	55 (5)	1	1312 858
	Right, S23, C71, C72, Est. Wgn., C70, C73, All . . . . .	8	-	-	56	56	1	1671 342
	Left, S23, C71, C72, Est. Wgn., C70, C73, All . . . . .	8	-	-	56	56	1	1671 343
	Right, S23 except Est. Wgn., S24 All . . . . .	8	-	-	56	-	1	1633 036
	Left, S23 except Est. Wgn., S24 All . . . . .	8	-	-	56	-	1	1633 037
	Right, S25, S26, LS2, LS3 . . . . .	8	-	-	57-58	-	1	1732 514
	Left, S25, S26, LS2, LS3 . . . . .	8	-	-	57-58	-	1	1732 515
	Right, C67, C68, except Est. Wgn., UP TO . . . . .	8	-	-	-	55 (1)	1	1318 570
	Left, C67, C68, except Est. Wgn., UP TO . . . . .	8	-	-	-	55 (1)	1	1318 571
	Right, C67, C68, except Est. Wgn., FROM TO, C68-300 UP TO . . . . .	8	-	-	-	55 (4)	1	1615 334
	Left, C67, C68, except Est. Wgn., FROM TO, C68-300 UP TO . . . . .	8	-	-	-	55 (4)	1	1615 335
	Right, C67, C68, Est. Wgn., C69 All, AFTER . . . . .	8	-	-	-	55 (5)	1	1671 456
	Left, C67, C68, Est. Wgn., C69 All, AFTER . . . . .	8	-	-	-	55 (5)	1	1671 457
	Right, C67, C68, except Est. Wgn., C68-300, AFTER . . . . .	8	-	-	-	55 (3)	1	1635 354
	Left, C67, C68, except Est. Wgn., C68-300, AFTER . . . . .	8	-	-	-	55 (3)	1	1635 355

NOTE 1:

C67 Windsor, except Est. Wgn.  
w/Power Strg. w/Booster Brake, W554800  
w/Power Strg. w/o Booster Brake, W555421  
w/o Power Strg. w/Booster Brake, W558651  
w/o Power Strg. w/o Booster Brake, W559564

C68 New Yorker, except Est. Wgn.  
w/Power Strg., N553099  
w/o Power Strg., N555371

NOTE 2: S21 Fireflite Serial No. 50330825

S22 Firedome Serial No. 55188534

NOTE 3:

C67 Windsor except Est. Wgn. After W55-55461  
C68-300 After 3N55-1871

C68 New Yorker except Est. Wgn. After N55-34085

NOTE 4:

C67 Windsor except Est. Wgn.  
w/Power Strg. w/Booster Brake from W55-4800 to W55-55461  
w/Power Strg. w/o Booster Brake from W55-5421 to W55-55461  
w/o Power Strg. w/Booster Brake from W55-8651 to W55-55461

w/o Power Strg. w/o Booster Brake from W55-9564 to W55-55461  
C68 New Yorker except Est. Wgn.  
w/Power Strg. from N55-3099 to N55-34085  
w/o Power Strg. from N55-5371 to N55-34085  
C68-300 Up To 3N55-1871

NOTE 5:

C67 Est. Wgn. Ser. No. W55-42579  
C69 All Ser. No. C55-10832

C68 Est. Wgn. Ser. No. N55-42579

★ Indicates use as required.

Numerals in parentheses ( ) refer to notes.

Printed in U.S.A.

☐ Indicates parts not listed in any previous parts book.

Prices and specifications subject to change without notice.

\* Indicates change or addition.

# 1955-58 PASSENGER CAR PARTS LIST

WHEELS

CODE	PART NAME AND DESCRIPTION	NO. OF CYL.	PLYMOUTH	DODGE	DESOTO	CHRYSLER AND IMPERIAL	PER CAP.	PART NUMBER
	HUB, w/HOUSING, Right, C70 Disc Brake . . .	8	-	-	-	55	1	*1486 969
	Left, C70 Disc Brake . . . . .	8	-	-	-	55	1	*1486 968
	Right, C71, C72, except Est. Wgn. . . . .	8	-	-	-	56	1	1637 326
	Left, C71, C72, except Est. Wgn. . . . .	8	-	-	-	56	1	1637 327
	Right, C75, C76 . . . . .	8	-	-	-	57	1	1732 288
	Left, C75, C76 . . . . .	8	-	-	-	57	1	1732 289
	Right, IM, LY1 . . . . .	8	-	-	-	57-58	1	1732 294
	Left, IM, LY1 . . . . .	8	-	-	-	57-58	1	1732 295
22-03-2	HUB and DRUM, Rear							
	Right, 10" Brake, P27, P29, except Sub. . . .	6-8	55-56	-	-	-	1	859 134
	Left, 10" Brake, P27, P29, except Sub. . . .	6-8	55-56	-	-	-	1	859 135
	Right, 11" Brake, P27, P29 . . . . .	8	55-56	-	-	-	1	1554 982
	Left, 11" Brake, P27, P29 . . . . .	8	55-56	-	-	-	1	1554 983
	Right . . . . .	6-8	57-58	-	-	-	1	1732 330
	Left . . . . .	6-8	57-58	-	-	-	1	1732 331
	Right . . . . .	6-8	-	55-56	-	-	1	1118 850
	Left . . . . .	6-8	-	55-56	-	-	1	1118 851
	Right, D63 w/12" Brake, All, C67, C68, except Est. Wgn. . . . .	8	-	56	-	55	1	1318 593
	Left, D63 w/12" Brake, All, C67, C68, except Est. Wgn. . . . .	8	-	56	-	55	1	1318 594
	Right, D63-D500 All, C71, C72, except Est. Wgn. . . . .	8	-	56	-	56	1	1637 330
	Left, D63-D500 All, C71, C72, except Est. Wgn. . . . .	8	-	56	-	56	1	1637 331
	11" Brakes, Right, D66 4 D. Spec. Cl Cp. Cl. Sed., D67 4 D. Sp. Cl. Cp., D72 All . . . . .	6-8	-	57	-	-	1	1734 162
	11" Brakes, Left, D66 4 D. Sp. Cl. Cp. - Cl. Sed., D67 4 D. Sp. Cl. Cp., D72 All . . . . .	6-8	-	57	-	-	1	1734 163
	11" Brakes, Right, D66 Sp. 4 D. - Cv. Cp., D67 Sp. 4 D., Cv. Cp., D70, D71, S27 All. . . . .	8	-	57	57	-	1	1730 826
	11" Brakes, Left, D66 Sp. 4 D., Cv. Cp., D67 Sp. 4 D., Cv. Cp., D70, D71, S27 All. . . . .	8	-	57	57	-	1	1730 827
	12" Brakes, Right, LP2, S27, LS1, LC1, LC2, LC3 . . . . .	8	58	57-58	57-58	58	1	1732 290
	12" Brakes, Left, LP2, S27, LS1, LC1, LC2, LC3 . . . . .	8	58	57-58	57-58	58	1	1732 291
	11" Brakes, Right, LD1, LD2-L1 Cl. Sed., Sp. Cl. Cp., 4 D., LD2-L2 Cl. Sed., Sp. Cl. Cp., 4 D., LD2-M Sp. Cl. Cp., 4 D., LD3-H Sp. Cl. Cp., 4 D. . . . .	6-8	-	58	-	-	1	1734 162
	11" Brakes, Left, LD1, LD2-L1 Cl. Sed., Sp. Cl. Cp., 4 D., LD2-L2 Cl. Sed., Sp. Cl. Cp., 4 D., LD2-M Sp. Cl. Cp., 4 D., LD3-H Sp. Cl. Cp., 4 D. . . . .	6-8	-	58	-	-	1	1734 163
	11" Brakes, Right, LD2-L1 Cv. Cp., Sp. 4 D., LD2-L2 Sp. 4 D., LD2-M Sp. 4 D., LD3-L, LD3-H Cv. Cp., Sp. 4 D., Sub., LS1, LC1 Except Sub. . . . .	6-8	-	58	58	58	1	*1730 826
	11" Brakes, Left, LD2-L1 Cv. Cp., Sp. 4 D., LD2-L2 Sp. 4 D., LD2-M Sp. 4 D., LD3-L, LD3-H Cv. Cp., Sp. 4 D., Sub., LS1, LC1 Except Sub. . . . .	6-8	-	58	58	58	1	*1730 827
	Right, S21 All, S22 except Est. Wgn. . . . .	8	-	-	55	-	1	1401 950
	Left, S21 All, S22 except Est. Wgn. . . . .	8	-	-	55	-	1	1401 951
	Right, S22, C67, C68, Est. Wgn., C69 All. . . .	8	-	-	55	55	1	1311 217
	Left, S22, C67, C68, Est. Wgn., C69 All. . . .	8	-	-	55	55	1	1311 218
	Right, S23 except Est. Wgn., S24 All . . . . .	8	-	-	56	-	1	1633 054
	Left, S23 except Est. Wgn., S24 All . . . . .	8	-	-	56	-	1	1633 055
	Right, S23, C71, C72, Est. Wgn., C73 All . . .	8	-	-	56	56	1	1637 336
	Left, S23, C71, C72, Est. Wgn., C73 All . . .	8	-	-	56	56	1	1637 337
	Right, S25, S26, LS2, LS3 . . . . .	8	-	-	57-58	-	1	1732 512
	Left, S25, S26, LS2, LS3 . . . . .	8	-	-	57-58	-	1	1732 513
	Right, C70 . . . . .	8	-	-	-	55	1	1487 931
	Left, C70 . . . . .	8	-	-	-	55	1	1487 930

★ Indicates use as required. Numerals in parentheses ( ) refer to notes. Printed in U.S.A.  
 ☐ Indicates parts not listed in any previous parts book. Prices and specifications subject to change without notice.  
 Nov. 10, 1958 Supersedes Oct. 10, 1957. Page 22-6 \* Indicates change or addition.

PASSENGER CAR PARTS LIST 1955-58

CODE	PART NAME AND DESCRIPTION	NO. OF CYL.	PLYMOUTH	DODGE	DESOTO	CHRYSLER AND IMPERIAL	PER CAR	PART NUMBER
	Right, C70 . . . . .	8	-	-	-	56	1	1674 208
	Left, C70 . . . . .	8	-	-	-	56	1	1674 209
	Right, C75, C76 . . . . .	8	-	-	-	57	1	1732 290
	Left, C75, C76 . . . . .	8	-	-	-	57	1	1732 291
	Right, IM, LY1 . . . . .	8	-	-	-	57-58	1	1732 296
	Left, IM, LY1 . . . . .	8	-	-	-	57-58	1	1732 297
<b>22-04-0 BRAKE DRUM</b>								
22-04-1	DRUM, Front, 10" Brake . . . . .	6	55-56	-	-	-	2	1326 889
	11" Brake . . . . .	8	55	56	-	-	2	692 792
	11" Brake, P26, P28, P29, 3" wide . . . . .	6-8	55-56	-	-	-	2	692 791
	3 27/64" wide . . . . .	6-8	55-56	-	-	-	2	1638 423
		6-8	-	55-56	-	-	2	692 791
		6-8	57-58	-	-	-	2	1732 333
	D63 w/12" Brake, C68-300, All, C67, C68, except Est. Wgn., AFTER . . . . .	8	-	56	-	55 (2)	2	1635 357
	D63-D500, C70, C73, All, S23, C71, C72, Est. Wgn. . . . .	8	-	56	56	56	2	1637 335
	S27, LS1, LC1 except Sub. . . . .	6-8	-	57-58	57-58	58	2	*1730 822
	12" Brakes, LP2, S27, LS1, LC1 . . . . .	6-8	58	57-58	57-58	58	2	1732 293
	S22, C67, C68, Est. Wgn., C69 All, UP TO . . . . .	8	-	-	55	55 (1)	2	1311 212
	S23 except Est. Wgn., S24 All . . . . .	8	-	-	56	-	2	1633 043
	S21 All, S22 except Est. Wgn. . . . .	8	-	-	55	-	2	1401 953
	S25, S26, LS2, LS3 . . . . .	8	-	-	57-58	-	2	1732 516
	C71, C72, except Est. Wgn. . . . .	8	-	-	-	56	2	1637 329
	C67, C68, Est. Wgn., C69 All, AFTER . . . . .	8	-	-	-	55 (1)	2	1671 459
	C75, C76, LC2, LC3 . . . . .	8	-	-	-	57-58	2	1732 293
22-04-2	DRUM, Rear, P28 All, P29 except Sub. . . . .	6	55-56	-	-	-	2	651 777
		6-8	57-58	-	-	-	2	1732 333
		6-8	-	55-56	-	-	2	692 792
	D63-D500, C70, C73, All, S23, C71, C72, Est. Wgn. . . . .	8	-	56	56	56	2	1637 335
	11" Brakes, D66 4 D. - Sp. Cl. Cp. - Cl. Sed., D67 4 D. Sp. Cl. Cp., D72 All . . . . .	6-8	-	57	-	-	2	1734 165
	11" Brakes, D66 Sp. 4 D. - Cv. Cp., D67 Sp. 4 D. - Cv. Cp., D70, D71, S27 All . . . . .	8	-	57	57	-	2	1730 822
	12" Brakes, LP2, S27, LS1, LC1 . . . . .	6-8	58	57-58	57-58	58	2	1732 293
	11" Brakes, LD1, LD2-L1, Cl. Sed., Sp. Cl. Cp., 4 D., LD2-L2, Cl. Sed., Sp. Cl. Cp., 4 D., LD2-M, Sp. Cl. Cp., 4 D., LD3-H, Sp. Cl. Cp., 4 D. . . . .	6-8	-	58	-	-	2	1734 165
	11" Brakes, LD2-L, Cv. Cp., Sp. 4 D., LD2-L2, Sp. 4 D., LD2-M, Sp. 4 D., LD3-L, LD3-H, Cv. Cp., Sp. 4 D., Sub. . . . .	8	-	58	58	58	2	*1730 822
	LS1, LC1 except Sub. . . . .	8	-	58	58	58	2	*1730 822
	S21 All, S22 except Est. Wgn. . . . .	8	-	-	55	-	2	1401 953
	S22, C67, C68, Est. Wgn., C69 All . . . . .	8	-	-	55	55	2	1311 212
	S23 except Est. Wgn., S24 All . . . . .	8	-	-	56	-	2	1633 043
	S25, S26, LS2, LS3 . . . . .	8	-	-	57-58	-	2	1732 516
	C71, C72, except Est. Wgn. . . . .	8	-	-	-	56	2	1637 329
	C75, C76, LC2, LC3 . . . . .	8	-	-	-	57-58	2	1732 293
22-04-5	PACKAGE, Brake Drum Dampener Clip, IM1, LY1 . . . . .	8	-	-	-	57-58	1	1879 420
22-04-10	BAND, Dampener, C67, C68 . . . . .	8	-	-	55	55	★	1329 910
22-04-11	SPRING, w/311 Coils, 28 31/32" lgh. . . . .	6	55-56	-	-	-	★	1142 316
	w/344 Coils, 32" lgh., S27 . . . . .	6-8	55-57	55-57	57	-	★	1142 259
	w/379 Coils, 35 3/16" lgh., S25, S26 . . . . .	8	-	56	55-57	55-57	★	1142 258
	w/27 Coils, 3 3/4" lgh. . . . .	8	-	-	55	55	★	1488 425
	w/22 Coils, 3 1/8" lgh. . . . .	8	-	-	-	55	★	1404 979
	w/396 Coils 37" lgh. . . . .	8	-	-	-	55	★	1325 150

NOTE 1:

C67 Est. Wgn. W55-74957

C68 Est. Wgn. N55-42579, C69 C55-10832

NOTE 2:

C67 except Est. Wgn., Ser. No. W55-55461

C68 except Est. Wgn., Ser. No. N55-34085

C68-300, Ser. No. 3N55-1871

★ Indicates use as required.

Numerals in parentheses ( ) refer to notes.

Printed in U.S.A.

⊠ Indicates parts not listed in any previous parts book.

Prices and specifications subject to change without notice.

\* Indicates change or addition.

# 1955-58 PASSENGER CAR PARTS LIST

WHEELS

CODE	PART NAME AND DESCRIPTION	NO. OF CYL.	PLYMOUTH	DODGE	DESOTO	CHRYSLER AND IMPERIAL	PER CAR	PART NUMBER
	w/379 Coils, 35 3/16" lgh., LP2 . . . . .	6-8	58	58	58	58	★	1142 258
	w/344 Coils, 32" lgh., LS1, LC1 . . . . .	6-8	58	58	58	58	★	1142 259
22-04-20	DUSTER, C70 . . . . .	8	-	-	-	55	4	1405 008
22-04-34	CLIP, Dampener Spring, C70 . . . . .	8	-	-	-	55	40	1320 016
22-04-39	SHIELD, Hose, C70 . . . . .	8	-	-	-	55	2	1554 265
<b>22-05-0 WHEEL HUB</b>								
22-05-1	HUB, Front, Right, UP TO . . . . .	6	55 (1)	-	-	-	1	1483 002
	Left, UP TO . . . . .	6	55 (1)	-	-	-	1	1483 003
	Right, AFTER . . . . .	6	55-58 (1)	-	-	-	1	1615 324
	Left, AFTER . . . . .	6	55-58 (1)	-	-	-	1	1615 325
	11" Brakes, 3/8" thick Wheel Mounting Flange . . . . .	6-8	55-56	-	-	-	2	1618 576
	1/2" thick Wheel Mounting Flange . . . . .	6-8	55-56	-	-	-	2	1635 353
	D63 w/12" Brake . . . . .	6-8	-	55-56	-	-	2	1615 321
	11" Brakes, S27, LS1, LC1 except Sub. . . . .	8	-	56	-	-	2	1635 353
	Right, S21 All, S22, C67, C68, except Est. Wgn, UP TO . . . . .	6-8	-	57-58	57-58	58	2	1730 823
	Left, S21 All, S22, C67, C68, except Est. Wgn., UP TO . . . . .	8	-	-	55 (2)	55 (2)	1	1483 002
	Right, S21, All, S22, AFTER, C67, C68, except Est. Wgn., FROM TO C68-300 UP TO . . . . .	8	-	-	55 (2)	55 (3)	1	1615 324
	Left, S21 All, S22, AFTER, C67, C68, except Est. Wgn., FROM TO Note C68-300 UP TO . . . . .	8	-	-	55 (2)	55 (3)	1	1615 325
	Right, S22 Est. Wgn. . . . .	8	-	-	55	-	1	1312 859
	S23, C71, C72, Est. Wgn., C70, C73, IM, LY1, All . . . . .	8	-	-	56	56-58	2	1671 346
	C67, C68, except Est. Wgn., C68-300, AFTER . . . . .	8	-	-	-	55 (4)	2	1635 353
	C67, C68, Est. Wgn., C69 All . . . . .	8	-	-	-	55	2	1671 460
22-05-5	HUB, Rear, Right . . . . .	6-8	55-56	-	-	-	1	859 136
	Left . . . . .	6-8	55-56	-	-	-	1	859 137
	Right . . . . .	6-8	57-58	-	-	-	1	1732 498
	Left . . . . .	6-8	57-58	-	-	-	1	1732 499
	Right, D63 w/12" Brake . . . . .	6-8	-	55-56	-	-	2	1118 873
	Left, D63 w/12" Brake . . . . .	8	-	56	-	-	1	1318 574
		8	-	56	-	-	1	1318 575

NOTE 1:  
P26 approximate Ser. No. 13842484.

NOTE 2:  
S21 Fireflite Ser. No. 50330825, S22 Firedome Ser. No. 55188534 except Est. Wgn.  
C67 Windsor except Est. Wgn. C68 New Yorker except Est. Wgn.  
w/Power Strg. w/Booster Brake W55-4800 w/o Power Strg. N55-5371  
w/Power Strg. w/o Booster Brake W55-5421 w/Power Strg. N55-3099  
w/o Power Strg. w/Booster Brake W55-8651  
w/o Power Strg. w/o Booster Brake W55-9564

NOTE 3:  
C67 Windsor except Est. Wgn. to W55-55461  
w/Power Strg. w/Booster Brake from W55-4800 to C68 New Yorker except Est. Wgn.  
W55-55461 w/Power Strg. from N55-3099 to N55-34085  
w/Power Strg. w/o Booster Brake from W55-5421 to w/o Power Strg. from N55-5371 to N55-34085  
W55-55461 C68-300 Up To 3N55-1871  
w/o Power Strg. w/Booster Brake from W55-8651 to W55-55461  
w/o Power Strg. w/o Booster Brake from W55-9564

NOTE 4:  
C67 Windsor except Est. Wgn. After W55-55461 C68 New Yorker except Est. Wgn. After N55-34085  
C68-300 After 3N55-1871



CODE	PART NAME AND DESCRIPTION	NO. OF CYL.	PLYMOUTH	DODGE	DESOTO	CHRYSLER AND IMPERIAL	PER CAR	PART NUMBER
	D63-D500 . . . . .	8	-	56	-	-	2	1633 048
	11" Brakes, S27, LS1, LC1 except sub. . . . .	6-8	-	57-58	57-58	58	2	*1730 828
	Right, S21 All, S22, C67, C68, except Est. Wgn.	8	-	-	55	55	1	1318 574
	Left, S21 All, S22, C67, C68, except Est. Wgn.	8	-	-	55	55	1	1318 575
	Right, S22, C67, C68, Est. Wgn., C69 All. . . . .	8	-	-	55	55	1	1118 866
	12" Brakes, LP2, S23, C71, C72, except Est. Wgn., S24, C75, C76, LC1, LC2, LC3 . . . . .	6-8	58	57-58	56-58	56-58	2	1633 048
	S23, C71, C72, Est. Wgn., C73 All . . . . .	8	-	-	56	56	2	1633 049
	C70 . . . . .	8	-	-	-	56	2	1633 058
	IM, LY1 . . . . .	8	-	-	-	57-58	2	1671 507
22-05-14	BOLT, Right, P26, P28, D63 w/12" Brakes, S21, All, S22, C67, C68, except Est. Wgn., C68-300, UP TO . . . . .	6-8	55-58	56	55	55 (2)	★	393 984
	Left, P26, P28, D63 w/12" Brakes, S21, All, S22, C67, C68, except Est. Wgn., C68-300, UP TO . . . . .	6-8	55-58	56	55	55 (2)	★	856 981
	Right, S22, C67, C68, Est. Wgn., C69 All. . . . .	8	-	-	55	55	10	386 985
	Left, S22, C67, C68, Est. Wgn., C69 All. . . . .	8	-	-	55	55	10	856 982
	STUD, Right, 11" Brakes, S27, LS1, LC1, except Sub. . . . .	6-8	55-56	55-58	57-58	58	★	* 687 901
	Left, 11" Brakes, S27, LS1, LC1 except Sub. . . . .	6-8	55-56	55-58	57-58	58	★	* 687 902
	Right, D63-D500 . . . . .	8	-	56	-	-	10	1633 050
	Left, D63-D500 . . . . .	8	-	56	-	-	10	1633 051
	Right, Front, D63 w/12" Brake . . . . .	8	-	56	-	-	5	1635 374
	Left, Front, D63 w/12" Brake . . . . .	8	-	56	-	-	5	1635 375
	Right, Front, C67, C68, except Est. Wgn., C68-300, UP TO . . . . .	8	-	-	-	55 (2)	5	687 901
	Right, Front, C67, C68, except Est. Wgn., C68-300, AFTER . . . . .	8	-	-	-	55 (2)	5	1635 374
	Right, Front, C67, C68, Est. Wgn., C69 All, UP TO . . . . .	8	-	-	-	55 (1)	5	1635 374
	Left, Front, C67, C68, except Est. Wgn., C68-300, UP TO . . . . .	8	-	-	-	55 (2)	5	687 902
	Left, Front, C67, C68, except Est. Wgn., C68-300, AFTER . . . . .	8	-	-	-	55 (2)	5	1635 375
	Left, Front, C67, C68, Est. Wgn., C69 All, UP TO . . . . .	8	-	-	-	55 (1)	5	1635 375
	Right, Front, S22, C67, C68, Est. Wgn., C69 All, AFTER . . . . .	8	-	-	55	55 (1)	5	1671 474
	Left, Front, S22, C67, C68, Est. Wgn., C69 All, AFTER . . . . .	8	-	-	55	55 (1)	5	1671 475
	Right, C70 . . . . .	8	-	-	-	55	10	1407 410
	Left, C70 . . . . .	8	-	-	-	55	10	1407 411
	Right, 12" Brakes, LP2 All, S23, C71, C72, except Est. Wgn., S24, C75, C76, LC1, LC2, LC3 . . . . .	6-8	58	57-58	56-58	56-58	10	1633 050
	Left, 12" Brakes, LP2 All, S23, C71, C72, except Est. Wgn., S24, C75, C76, LC1, LC2, LC3 . . . . .	6-8	58	57-58	56-58	56-58	10	1633 051
	Right, S23, C71, C72, Est. Wgn., C70, C73, IM, LY1 . . . . .	8	-	-	56	56-58	10	1633 052
	Left, S23, C71, C72, Est. Wgn., C70, C73, IM, LY1 . . . . .	8	-	-	56	56-58	10	1633 053
22-05-24	NUT, Right, LP2, S24, C67, C68, C69, All, S23, C71, C72, except Est. Wgn., C75, C76, LC1, LC2, LC3 . . . . .	6-8	55-58	55-58	56-58	56-58	★	1139 316
	Left, LP2, S24, C67, C68, C69, All, S23, C71, C72, except Est. Wgn., C75, C76, LC1, LC2, LC3 . . . . .	6-8	55-58	55-58	56-58	56-58	★	1139 317

NOTE 1:

C67 Est. Wgn. Ser. No. W55-74957  
 C68 Est. Wgn. Ser. No. N55-42579

C69 Ser. No. C55-10832

NOTE 2:

C67 except Est. Wgn. Ser. No. W55-55461  
 C68-300 Ser. No. 3N55-1871

C68 except Est. Wgn. Ser. No. N55-34085

\* Indicates use as required.

Numerals in parentheses ( ) refer to notes.

Printed in U.S.A.

⊔ Indicates parts not listed in any previous parts book.

Prices and specifications subject to change without notice.

\* Indicates change or addition.

# 1955-58 PASSENGER CAR PARTS LIST

WHEELS

CODE	PART NAME AND DESCRIPTION	NO. OF CYL.	PLYMOUTH	DODGE	DESOTO	CHRYSLER AND IMPERIAL	PER CAR	PART NUMBER
	Right, S23, C71, C72, Est. Wgn., C70, C73, IM, LY1	8	-	-	56	55-58	10	1315 697
	Left, S23, C71, C72, Est. Wgn., C70, C73, IM, LY1	8	-	-	56	55-58	10	1315 698
<b>22-06-0 FRONT WHEEL BEARINGS</b>								
22-06-1	CONE and ROLLER, Inner, P26, S21, All, S22, C67, C68, except Est. Wgn., UP TO	6-8	55 (1)	-	55 (1)	55 (1)	2	1139 294
	Outer, P26, S21, All, S22, C67, C68, except Est. Wgn., UP TO	6-8	55 (1)	-	55 (1)	55 (1)	2	1139 292
	Inner, S21, S24, All, S22, S23, C67, C68, C71, C72, except Est. Wgn., C75, C76, LC1, LC2, LC3, AFTER	6-8	55-58 (1)	55-58	55-58 (1)	55-58 (1)	2	1619 701
	Outer, S21, S24, All, S22, S23, C67, C68, C71, C72, except Est. Wgn., C75, C76, LC1, LC2, LC3, AFTER	6-8	55-58 (1)	55-58	55-58 (1)	55-58 (1)	2	1619 703
	Inner, S22, C67, C68, Est. Wgn., C69 All	8	-	-	55	55	2	698 391
	Outer, S22, C67, C68, Est. Wgn., C69 All	8	-	-	55	55	2	698 402
	Inner, S23, C71, C72, Est. Wgn., C70, C73, IM, LY1	8	-	-	56	56-58	2	1789 755
	Outer, S23, C71, C72, Est. Wgn., C70, C73, IM, LY1	8	-	-	56	56-58	2	*1790 241
	Inner, C70 All	8	-	-	-	55	2	854 618
	Outer, C70 All	8	-	-	-	55	2	622 267
22-06-2	CUP, Inner, P26, S21, All, S22, C67, C68, except Est. Wgn., UP TO	6-8	55 (1)	-	55 (1)	55 (1)	2	1139 293
	Outer, P26, S21, All, S22, C67, C68, except Est. Wgn., UP TO	6-8	55 (1)	-	55 (1)	55 (1)	2	1139 291
	Inner, S21, S24, All, S22, S23, C67, C68, C71, C72, except Est. Wgn., C75, C76, LC1 except Sub., LC2, LC3, AFTER	6-8	55-58 (1)	55-58	55-58 (1)	55-58 (1)	2	1619 700
	Outer, S21, S24, All, S22, S23, C67, C68, C71, C72, except Est. Wgn., C75, C76, LC1 except Sub., LC1, LC2, AFTER	6-8	55-58 (1)	55-58	55-58 (1)	55-58 (1)	2	1619 702
	Inner, S22, C67, C68, Est. Wgn., C69 All	8	-	-	55	55	2	698 390
	Outer, S22, C67, C68, Est. Wgn., C69 All	8	-	-	55	55	2	698 401
	Inner, S23, C71, C72, Est. Wgn., C70, C73, IM, LY1	8	-	-	56	56-58	2	1789 754
	Outer, S23, C71, C72, Est. Wgn., C70, C73, IM, LY1	8	-	-	56	56-58	2	1790 244
	Inner, C70 All	8	-	-	-	55	2	854 617
	Outer, C70 All	8	-	-	-	55	2	622 266
22-06-5	NUT, S21, S24, All, S22, S23, C67, C68, C71, C72, except Est. Wgn.	6-8	55-56	55-56	55-56	55-56	2	33 208
	S22, S23, C67, C68, C71, C72, Est. Wgn., C69, C70, C73, All	8	-	-	55-56	55-56	2	53 553
		6-8	57-58	57-58	57-58	57-58	2	1732 300
		6-8	57-58	57-58	57-58	57-58	2	1673 324
22-06-10	LOCK, Bearing Nut	6-8	55-58	55-58	55-58	55-58	2	600 194
22-06-14	WASHER, S21, S24, All, S22, S23, C67, C68, C71, C72, except Est. Wgn.	8	-	-	55	55	2	*1671 339
	S22, C67, C68, Est. Wgn., C69, C70, All	8	-	-	56	56	2	1671 339
	S23, C71, C72, Est. Wgn., C70, C73, All	6	55 (1)	-	-	-	2	1489 102
22-06-18	SEAL, Dust, UP TO	6-8	55-58 (1)	55-58	55-58 (1)	55-58 (1)	2	1613 409
	S21, S24, All, S22, S23, C67, C68, C71, C72, except Est. Wgn., C75, C76, LC1, LC2, LC3, AFTER	6-8	55-58 (1)	55-58	55-58 (1)	55-58 (1)	2	1613 409

**NOTE 1:**

P26 approximate Ser. No. 13842484  
 S21 FireFlite Ser. No. 50330825  
 C67 Windsor except Est. Wgn.  
 w/Power Strg. w/Booster Brake W55-4800  
 w/Power Strg. w/o Booster Brake W55-5421  
 w/o Power Strg. w/Booster Brake W55-8651  
 w/o Power Strg. w/o Booster Brake W55-9564

S22 Firedome Ser. No. 55188534  
 C68 New Yorker except Est. Wgn.  
 w/o Power Strg. w/Booster Brake N55-5371  
 w/Power Strg. w/Booster Brake N55-3099

★ Indicates use as required.

Numerals in parentheses ( ) refer to notes.

Printed in U.S.A.

⊠ Indicates parts not listed in any previous parts book.

Prices and specifications subject to change without notice.

Nov. 10, 1958 Supersedes Oct. 10, 1957.

\* Indicates change or addition.

CODE	PART NAME AND DESCRIPTION	NO. OF CYL.	PLYMOUTH	DODGE	DESOTO	CHRYSLER AND IMPERIAL	PER CAR	PART NUMBER
	S21 All, S22, C67, C68, except Est. Wgn., UP TO	8	-	-	55 (1)	55 (1)	2	1489 102
	S22, C67, C68, Est. Wgn., C69 All	8	-	-	55	55	2	650 328
	C70	8	-	-	-	55	2	650 329
	S23, C71, C72, Est. Wgn., C70, C73, IM, LY1	8	-	-	56	56-58	2	1671 340
<b>22-08-0 HUB CAPS</b>								
22-08-5	CAP	6-8	55-56	-	-	-	4	1554 989
	LP1-L, LP1-M, LP2-L, LP2-M	6-8	57-58	-	-	-	4	1674 211
	UP TO	6-8	-	56 (2)	-	-	4	1637 342
	AFTER	6	-	56 (2)	-	-	4	1674 189
		6-8	-	55	-	-	4	1559 664
		6-8	-	57	-	-	4	1732 321
		6-8	-	58	-	-	4	1828 400
	S25, S27, LS1, LS2	8	-	-	57-58	-	4	1732 338
	C75-1, LC1 except Sub.	8	-	-	-	57-58	4	*1736 676
	WIRE WHEEL, C71, C72, except Est. Wgn.	6-8	-	55	-	55-56	4	1533 286
22-08-17	CLIP	6-8	-	55-56	-	-	25	684 140
	C70	8	-	-	-	55-56	25	959 407
22-08-23	SPRING, Wire Wheel Cap, C71, C72, except Est. Wgn.	6-8	-	55	-	55-56	8	1533 287
22-08-57	CAP, Grease, P26, D55, D56, S21, All, S22, C67, C68, except Est. Wgn., UP TO	6-8	55 (1)	55	55 (1)	55 (1)	2	600 183
	S21, S24, All, S22, S23, C67, C68, C71, C72, except Est. Wgn., C75, C76, LC1, LC2, LC3, AFTER	6-8	55-58 (1)	56-58	55-58 (1)	55-58 (1)	2	1613 416
	S23, C71, C72, Est. Wgn., C70, C73, IM, LY1	8	-	-	56	56-58	2	1671 341
	C67, C68, Est. Wgn., C69 All	8	-	-	-	55	2	633 405
	C70 All	8	-	-	-	55	2	313 827
<b>22-09-0 WHEEL BALANCE WEIGHT</b>								
22-09-1	WEIGHT, 1/2 oz.	6-8	55-58	55-58	55-58	55-58	★	1615 349
	1 oz.	6-8	55-58	55-58	55-58	55-58	★	1615 350
	1 1/2 oz.	6-8	55-58	55-58	55-58	55-58	★	1615 351
	2 oz.	6-8	55-58	55-58	55-58	55-58	★	1615 352
	2 1/2 oz.	6-8	55-58	55-58	55-58	55-58	★	1615 353
	3 oz.	6-8	55-58	55-58	55-58	55-58	★	1615 354
<b>22-20-0 SPARE WHEEL CARRIER</b>								
22-20-29	PLATE, Spare Wheel Mounting, P30, P31, D70, D71, 4 D. Sub. 3 Seat	6-8	57	57	-	-	1	1777 909
	BRACKET, Stud, S22, S23, C67, C68, C71, C72, except Est. Wgn., S21, S24, C69, C70, C73, All	8	-	-	55-56	55-56	1	1547 736
	BRACKET, Spare Wheel Support, D66, D67, D72, except Cv. Cp.	6-8	-	57	-	-	1	1777 459
	LD1 4 D., Cl.Sed., LD2 4 D., Sp. 4 D., Cl.Sed., Sp.Cl.Cp., LD3 4 D., Sp. 4 D., Sp.Cl.Cp.	6-8	-	58	-	-	1	1777 459
	PLATE, LD3 2 D. Sub., 4 D., 3 Seat Sub.	6-8	-	58	-	-	1	1777 909

NOTE 1:

P26 approximate Ser. No. 13842484  
 S21 FireFlite Ser. No. 50330825  
 C67 Windsor except Est. Wgn.  
 w/Power Strg. w/Booster Brake W55-4800  
 w/Power Strg. w/o Booster Brake W55-5421  
 w/o Power Strg. w/Booster Brake W55-8651  
 w/o Power Strg. w/o Booster Brake W55-9564

S22 Firedome Ser. No. 55188534  
 C68 New Yorker except Est. Wgn.  
 w/o Power Strg. w/Booster Brake N55-5371  
 w/Power Strg. w/Booster Brake N55-3099

NOTE 2:

D62 Ser. No. 32231744 except Wheel Covers

★ Indicates use as required.

Numerals in parentheses ( ) refer to notes.

Printed in U.S.A.

⊠ Indicates parts not listed in any previous parts book.

Prices and specifications subject to change without notice.

\* Indicates change or addition.

# 1955-58 PASSENGER CAR PARTS LIST

WHEELS

CODE	PART NAME AND DESCRIPTION	NO. OF CYL.	PLYMOUTH	DODGE	DESOTO	CHRYSLER AND IMPERIAL	PER CAR	PART NUMBER
22-20-80	PLATE, D55, Sub., D56 Sub., D62, D63, S21, S24, All . . . . .	6-8	55-56	55-56	55-56	-	1	1317 478
	except Sub., S25, S26 . . . . .	6-8	-	-	57	-	1	1317 478
	D55, D56, except Sub., S22, S23, C67, C68, C71, C72, except Est. Wgn., UP TO . .	6-8	-	55 (1)	55-56	55-56	1	1317 478
	S22, S23, C67, C68, C71, C72, Est. Wgn., C69, C70, C73, All . . . . .	8	-	-	55-56	55-56	1	1317 673
	Spare Wheel Anchor LC1, LC2, LC3 . . . . .	6-8	58	58	58	58	1	1317 478
	IM1, LY1, . . . . .	8	-	-	-	58	1	1750 747
22-20-82	RETAINER, Spare Wheel Anchor Bolt, P30, P31, LP1, LP2, D70, D71, LD3, 4 D. Sub. 3 Seat . . . . .	6-8	57-58	57-58	-	-	1	6000 381
22-20-84	WASHER, Spare Wheel Anchor Bolt, P30, P31, D70, D71, 4 D. Sub. 3 Seat	6-8	57	57	-	-	1	1833 983
22-20-85	SPRING, Spare Wheel Anchor Bolt, D70, D71, Sub. . . . .	6-8	57	57	-	-	1	1777 668
22-20-87	STUD, except Sub. UP TO . . . . .	6-8	55-56	55-56 (1)	-	-	1	1475 243
	except Sub., AFTER . . . . .	6-8	-	55 (1)	-	-	1	1475 123
	Sub. . . . .	6-8	55-56	55-56	-	-	1	1405 086
	Rod, C75, C76, LC1, LC2, LC3 . . . . .	6-8	57-58	57-58	57-58	57-58	1	1708 892
	IM, LY1 . . . . .	8	-	-	-	57-58	1	1751 782
	LY1, with 11" Tire . . . . .	8	-	-	-	58	1	1878 529
	BOLT, P30, P31, D70, D71, 4 D. Sub. LD3 Sub. . . . .	6-8	57-58	57-58	-	-	1	1833 981
	S22, S23, C67, C68, C71, C72, Est. Wgn. . .	8	-	-	55-56	55-56	1	1321 831
	S22, S23, C67, C68, C71, C72, except Est. Wgn., S21, S24, C69, C70, C73, All . . . . .	8	-	-	55-56	55-56	1	1620 205
	ROD, 3 Cp. . . . .	6-8	55-56	-	-	-	1	1608 889
22-20-88	LOCK and KEY, Spare Wheel Anchor Bolt, LP1, LP2, P30, P31, LD3, D70, D71, Sub. .	6-8	57-58	57-58	-	-	1	1778 775
22-20-89	NUT, Wing . . . . .	6-8	55-58	55-58	55-58	55-58	1	6000 332
22-20-91	COVER, Brown, 3 Cp. . . . .	6	55-56	-	-	-	1	1609 867
	Green . . . . .	6	55	-	-	-	1	1609 868
	Blue . . . . .	6	55	-	-	-	1	1609 869
	Green . . . . .	6-8	56	-	-	-	1	1647 942
	Blue . . . . .	6-8	56	-	-	-	1	1647 943
	Gray . . . . .	6-8	56	-	-	-	1	1647 944
	Tan . . . . .	6-8	56	-	-	-	1	1655 825
22-20-92	SPRING, Cover, 3 Cp. . . . .	6	55	-	-	-	1	1496 389
22-20-93	HINGE, Cover, Est. Wgn. . . . .	8	-	-	55-56	55-56	3	1334 442
22-20-94	PIN, Hinge, Est. Wgn. . . . .	8	-	-	55-56	55-56	3	1334 445
22-20-103	BOLT, Wing, Est. Wgn. . . . .	8	-	-	55-56	55-56	2	1476 117
22-20-105	HOUSING, Cover, Est. Wgn. . . . .	8	-	-	55-56	55-56	2	1476 108
22-20-106	FERRULE, Est. Wgn. . . . .	8	-	-	55-56	55-56	1	1334 529
22-20-108	BRACKET, Prop, Est. Wgn. P30, P31, D70, D71, S26, S27, C75, C76. . . . .	8	57	57	55-57	55-57	1	1432 929
22-20-109	RIVET, Prop, Est. Wgn., D70, D71, S26, S27, C75, C76, Sub. . . . .	6-8	57	57	55-57	55-57	1	893 923
22-20-112	HOLDER, Est. Wgn. . . . .	8	-	-	55-56	55-56	1	1371 638
22-20-122	SCREW, Wing Bolt Housing, Est. Wgn. . . .	8	-	-	56	56	6	6000 348
22-20-125	SCREW, Ferrule, Est. Wgn. . . . .	8	-	-	56	56	2	6000 348

NOTE 1:

D55-Ser. No. 34850638 Det. Built -  
42522054 L. A. Built

D56 Coronet Ser. No. 32206943 Det Built -  
48016123 L. A. Built

★ Indicates use as required.

Numerals in parentheses ( ) refer to notes.

Printed in U.S.A.

⊠ Indicates parts not listed in any previous parts book.

Prices and specifications subject to change without notice.

Nov. 10, 1958 Supersedes Jan. 30, 1958.

\* Indicates change or addition.



