

TILT STEERING WHEEL



TRAINING PROGRAM BOOKLET

TECHNICAL SERVICE DEPARTMENT
CHEVROLET MOTOR DIVISION
GENERAL MOTORS CORPORATION

PART I

GENERAL INFORMATION

DESCRIPTION

Another step along the road to greater automotive comfort, convenience and safety is represented by tilt wheel steering.

Through its seven different positions (allowing a total adjustment at the steering wheel rim of approximately five inches), the optional tilt steering wheel provides the driver with greater ease of entry and exit as well as allowing him to adjust the angle of the wheel to meet his particular comfort and safety requirements. Wheel adjustment may be made at any time, even while the car is in motion, with no loss of steering control. This provides

the added advantage of allowing the driver to change the wheel position frequently during a long drive and thereby relax the arm and shoulder muscles. The relaxed driver is generally less fatigued and therefore more alert during a long trip.

There are two models of the tilt steering wheel assembly: one for use with the powerglide transmission and the other for use with the 4-speed (floor shift) transmission. The difference lies in the column shifting mechanism in the Powerglide model, which is not present in the 4-speed model. The tilting mechanism is identical in both models. The unit is

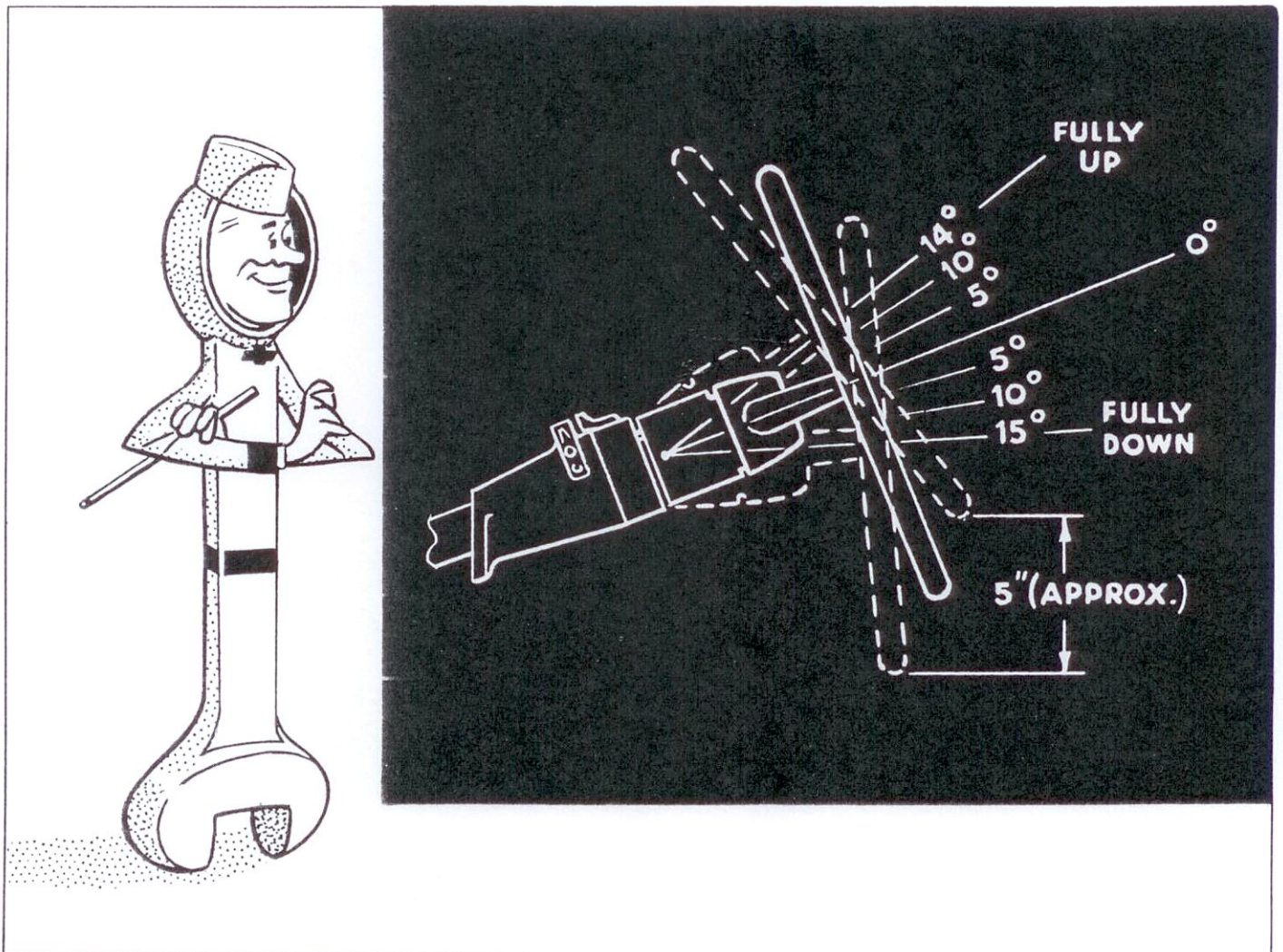

Fig. 1—Tilt Wheel Range of Adjustment

2 GENERAL INFORMATION

not available for use with the 3-speed (column shift) transmission.

CONSTRUCTION

The tilt wheel assembly has an upper and a lower steering shaft assembly joined by a universal joint consisting of a grooved two piece sphere within which a spring is installed to prevent joint looseness. The joint allows vertical movement of the upper shaft. A lock plate holds the support assembly to the top of the mast jacket and an actuator assembly is attached to the support by means of two pivot pins which allow up and down movement between the actuator and the support. Two tilt springs are attached between the upper edges of the support and the actuator. Upper and lower lock shoes, part of the actuator assembly, engage the locking pins in the support assembly to lock the unit in the desired

position. Upper and lower bearings, preloaded by means of a collapsible spacer, secure the upper shaft in the actuator assembly.

OPERATION

A short lever on the left side of the steering column controls the locking mechanism which secures the wheel in the selected position. The wheel is unlocked by moving this lever toward the driver. If not manually restrained, the spring loaded wheel will move into its fully "up" position.

When the release lever is moved the ramp end of each lock shoe moves inward, disengaging the support locking pins. The actuator assembly, upper shaft and steering wheel may now be moved to any of the seven different positions or, if no pressure is applied to the wheel, it will tilt to its uppermost position. Releasing the lever locks the wheel in position.

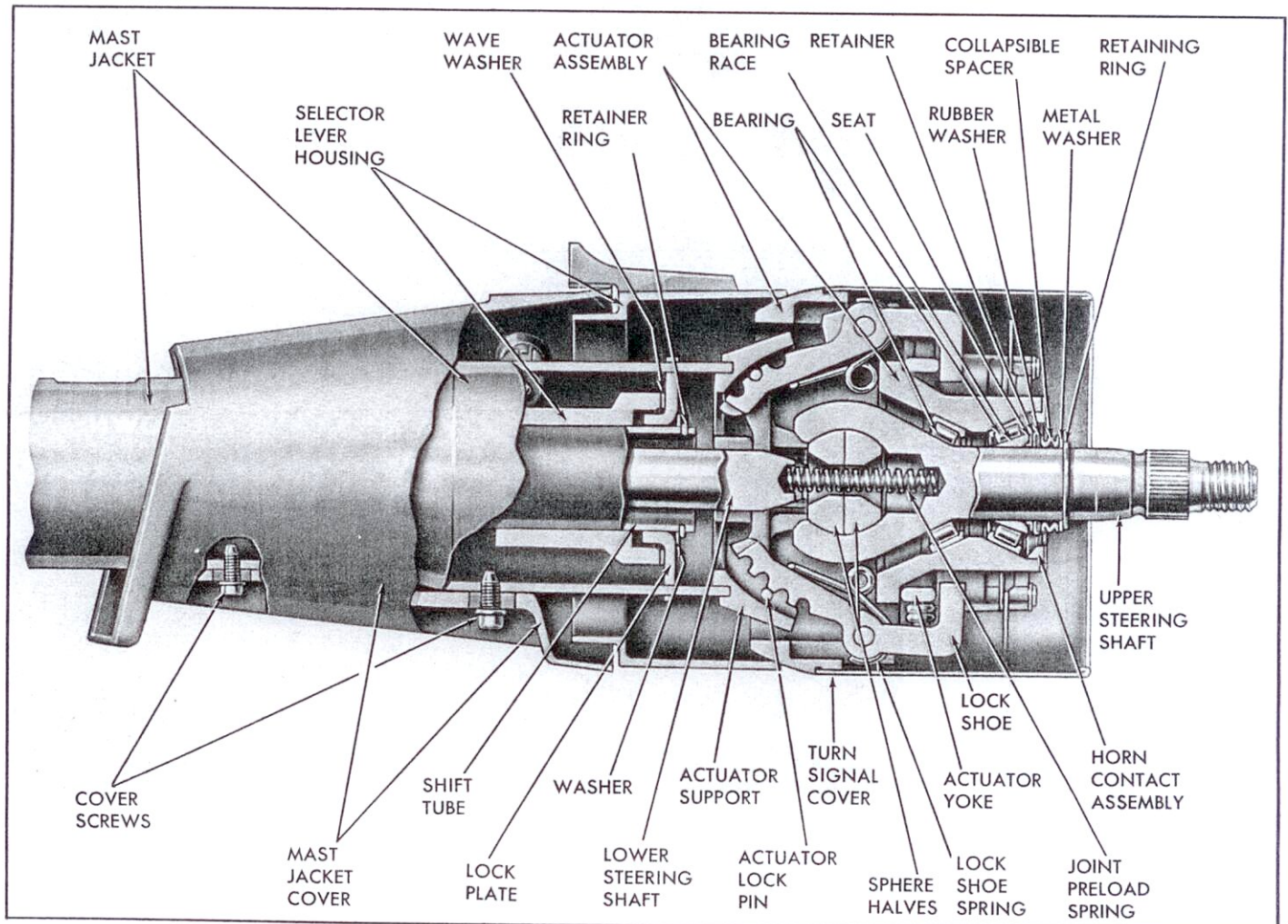

Fig. 2—Section View of the Powerglide Style Tilt Wheel Assembly

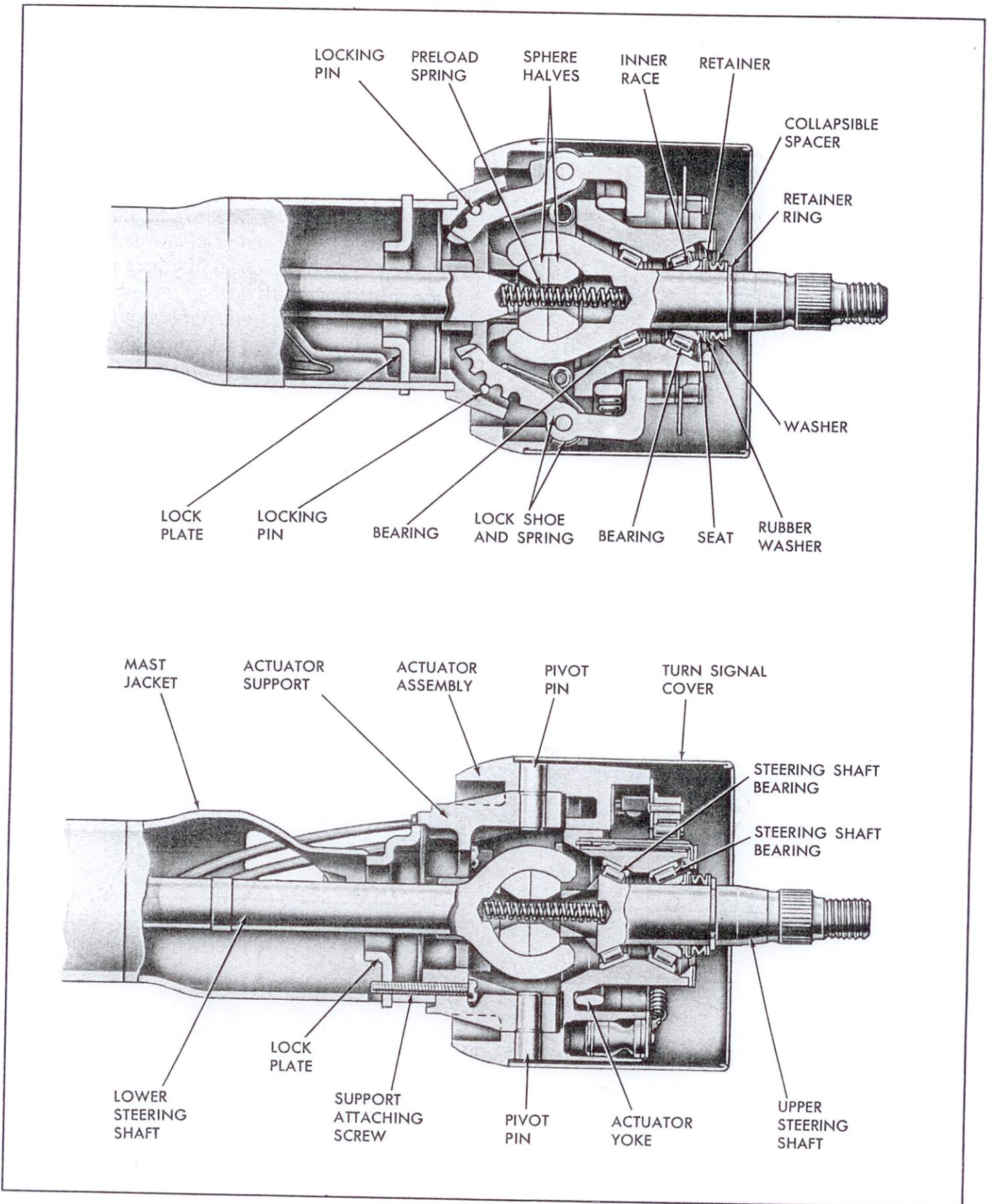

Fig. 3—Section Views of the Manual Transmission Style Tilt Wheel Assembly

4 GENERAL INFORMATION

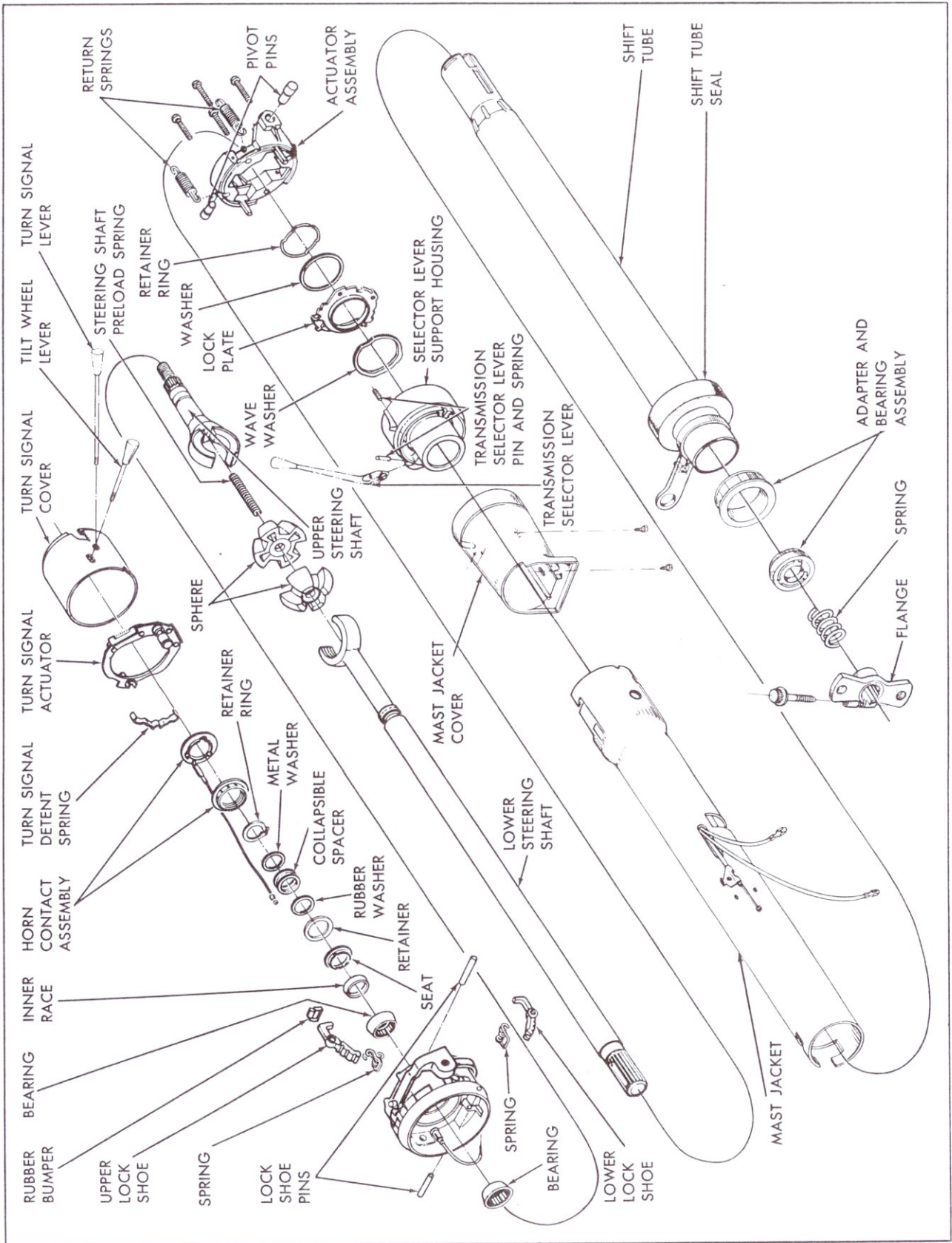

Fig. 4—Tilt Wheel Assembly—Exploded View

PART II

SERVICE PROCEDURES

It is assumed that most training center programs will include bench assembly and disassembly operations. Therefore, mast jacket removal procedure will be covered here. The service operations which follow mast jacket removal will be covered as bench operations. However, with the exception of the automatic transmission shift tube removal, all operations may be performed as well with the mast jacket on the vehicle.

REMOVAL OF THE MAST JACKET AND TILT WHEEL ASSEMBLY

In the engine compartment:

1. Disconnect the transmission linkage from shift lever (powerglide only).
2. Remove the screws attaching the seal assembly to the firewall.
3. Remove the two lower flange coupling attaching bolts and nuts.

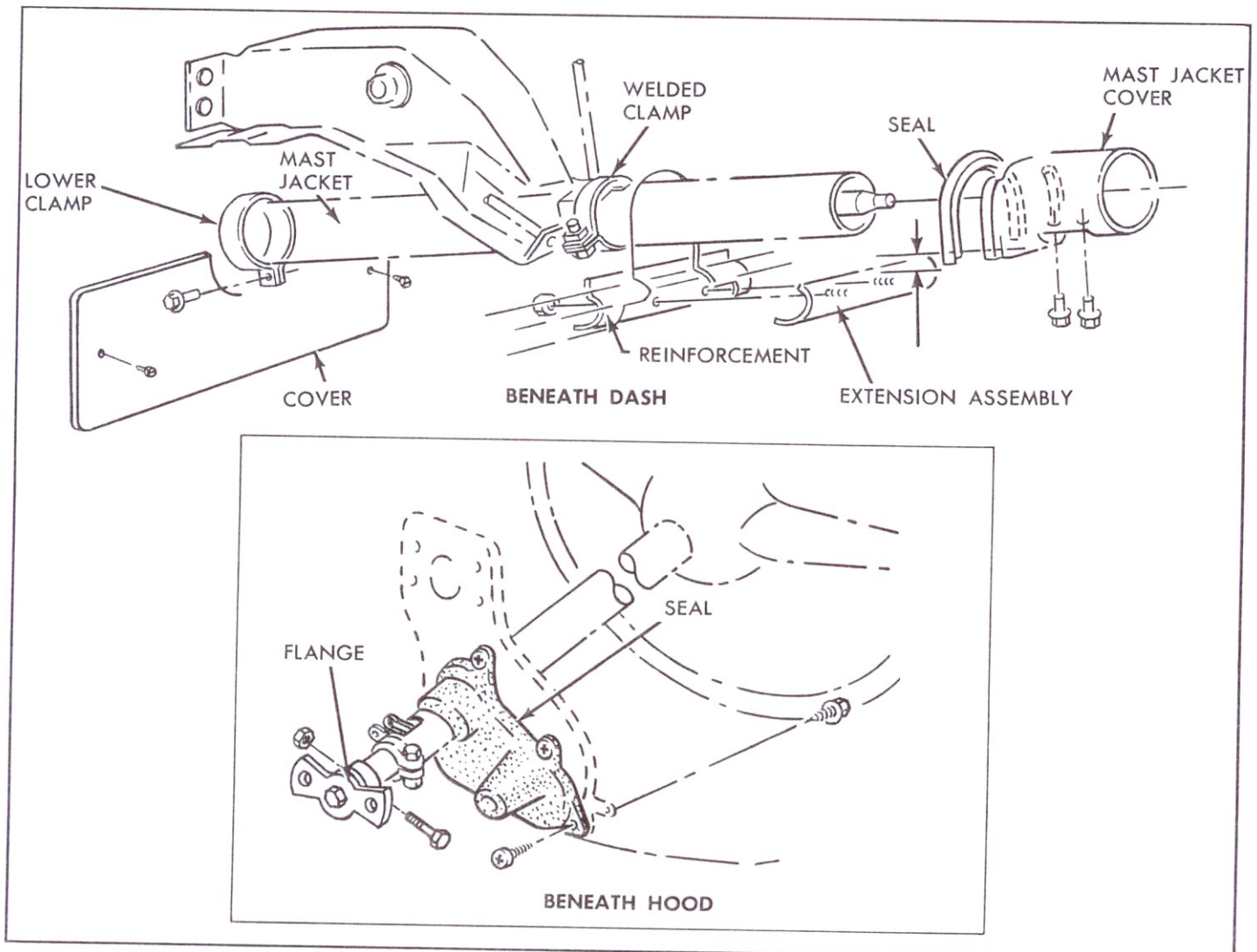

Fig. 5—Mast Jacket Removal

6 SERVICE PROCEDURES

Within the vehicle:

4. Remove the cover assembly from the fire-wall.
5. Remove the mast jacket clamp assembly.
6. Remove the nuts from the reinforcement plate behind the instrument panel flange and remove the extension trim assembly and the reinforcement plate.
7. Remove the nut and bolt from the welded-on clamp at the instrument panel and bend the clamp carefully down and to one side. Lower the mast jacket away from the instrument panel and remove the seals at the instrument panel opening.
8. Adjust the front seat as far rearward as it will go, then slowly pull the mast jacket assembly rearward turning as necessary to assist the rubber boot and, on power-glide models, the shift lever through the firewall.
9. Unplug wiring harness connectors as necessary and move the assembly to a bench for further disassembly.

INSTALLATION OF MAST JACKET AND TILT WHEEL ASSEMBLY

Within the vehicle

1. Adjust the seat fully rearward and carefully guide the mast jacket rubber boot and shift lever through the firewall, turning as necessary.
2. Install the seal at the instrument panel opening, then lift the mast jacket up and into place, bending the welded-on clamp as necessary to allow the mast jacket to be positioned within it. Tighten the clamp.
3. Install the instrument panel flange reinforcement plate, extension trim assembly and attaching bolts.
4. Install the mast jacket clamp assembly at the firewall.
5. Install the screw and cover assembly at the firewall.

In the engine compartment

6. Attach the seal assembly to the engine side of the firewall.
7. Install the lower flange attaching bolts and torque to 25-35 ft. lbs.
8. Attach the transmission linkage to the shift lever (powerglide only).
9. Plug in wiring harness connectors as necessary.

DISASSEMBLING THE TILT WHEEL STEERING COLUMN

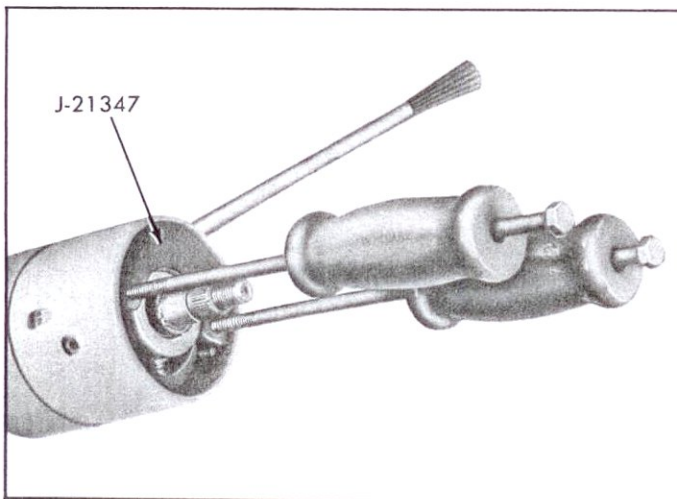

Fig. 6—Removing the Turn Signal Cover

1. Remove the turn signal switch, neutral safety switch (on powerglide equipped models), and back up lamp switch (if present) from the mast jacket.
2. Remove the steering wheel (if not previously removed) using Tool J-2927.
3. Remove the turn signal lever and the tilt lever.
4. Remove the turn signal cover using Tool J-21347 with slide hammers J-6585 and puller bolts J-9539. Tap cover off carefully applying force to one slide hammer at a time.

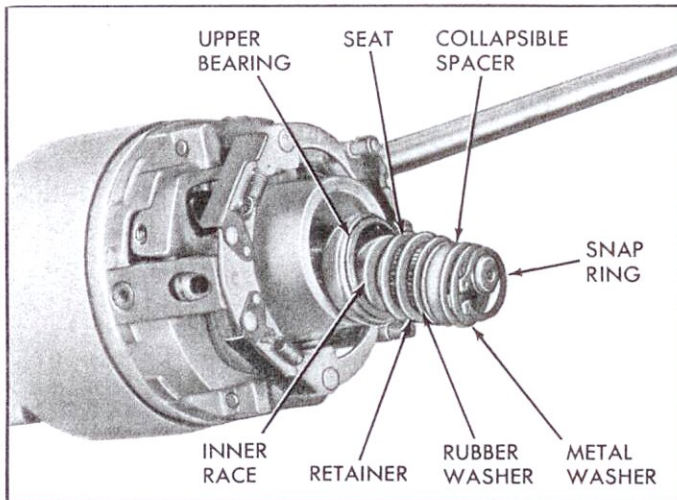

Fig. 7—Bearing Preload Parts

5. Pry the horn contact assembly from the actuator assembly and pull wire out part way.
6. Remove the snap ring, metal washer, collapsible spacer, rubber washer, retainer, seat, inner race and steering shaft upper bearing.

NOTE: Discard the collapsible spacer. Upon reassembly, a new spacer must be used.

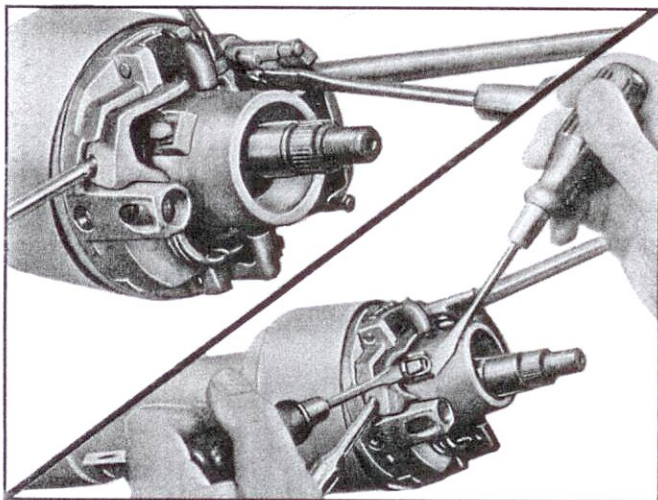

Fig. 8—Unseating Return Springs

7. Remove the turn signal actuator yoke and detent spring and the turn signal cable clamp attaching screw. Disconnect the cable from the turn signal bell crank.
8. Install the tilt release lever and move it so the tilt mechanism swings to its fully "up" position.

CAUTION: The unit will "snap" to the up position. Keep fingers clear.

9. Using a screwdriver, unseat the upper ends of the tilt return springs.

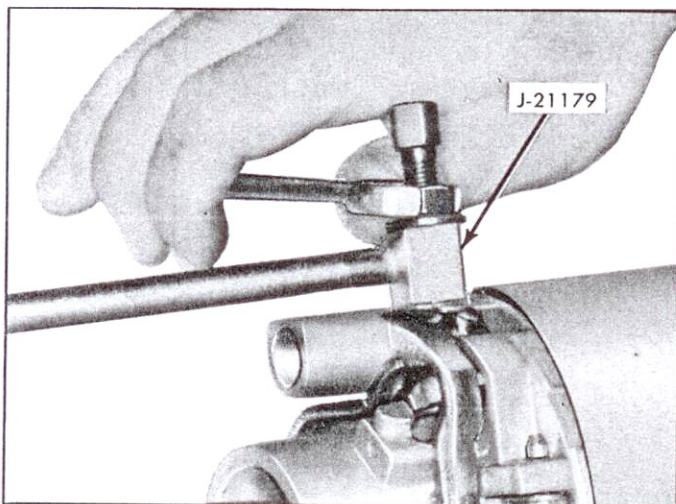

Fig. 9—Removal of Pivot Pins

10. Using Tool J-21179, remove the two pivot pins as follows: Install the nut and washer on the stud as shown and place the stud into the tool so it extends through the chamfered end of the hole in the tool. Position the tool between the locating bosses on the support assembly and thread the stud into the pivot pin. Hold the stud and turn the nut to remove the pin. Remove the second pin in the same manner.

8 SERVICE PROCEDURES

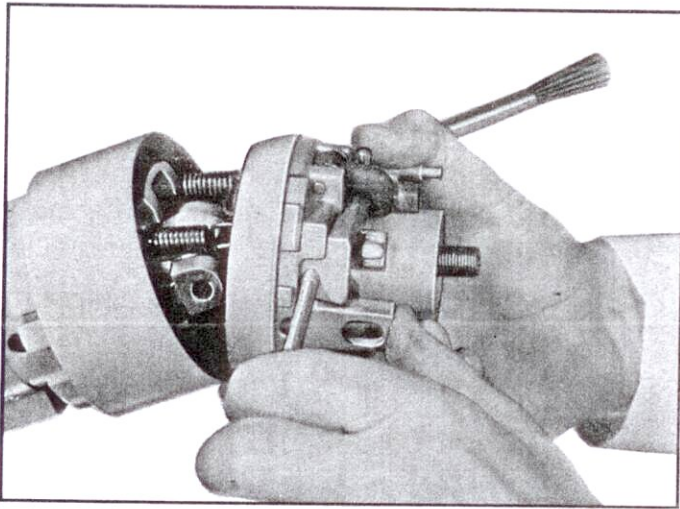

Fig. 10—Removing the Actuator Assembly

11. Lift the tilt lever to disengage the lock shoes from the support locking pins and remove the actuator assembly, leaving the turn signal cable in the mast jacket.

NOTE: During this operation it will be necessary to carefully guide the turn signal cable clamp down through the actuator assembly.

12. Remove the tilt springs from the support.

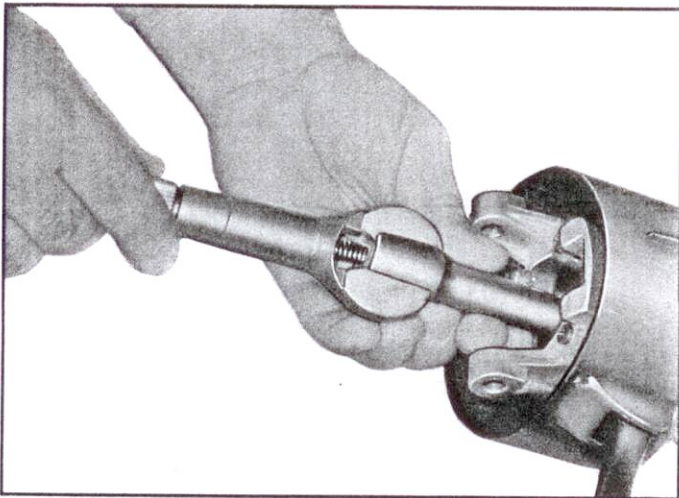

Fig. 11—Removing the Steering Shaft

13. Carefully remove the lower bearing from the upper steering shaft taking care that bearing does not catch on snap ring groove.
14. Remove the flange attaching bolt at the lower end of the steering shaft and remove flange and spring.
15. Remove the steering shaft assembly upward through the mast jacket.

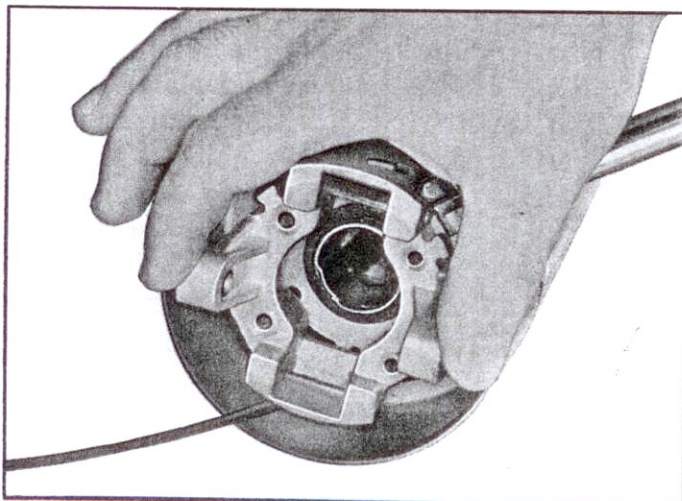

Fig. 12—Actuator Support

16. Remove the four actuator support screws and the support from the mast jacket.
17. Remove the turn signal switch control cable after first removing the two mast jacket cover attaching bolts.

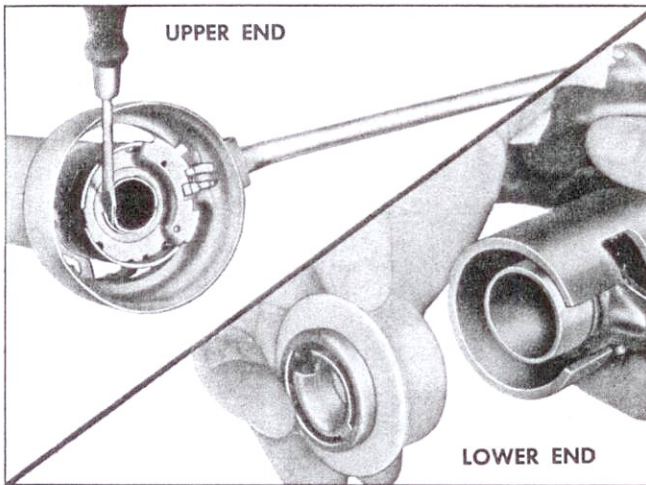

Fig. 13—Shift Tube Retainer Ring, Washer and Lower Bushing

18. From the top of the shift tube, remove the shift tube retainer ring and washer.
19. From the lower end of the mast jacket, remove the shift tube bearing retainer.

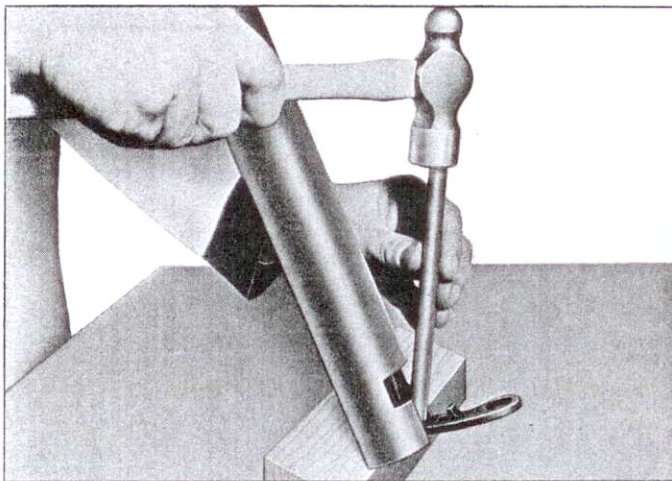

Fig. 14—Removing the Shift Tube

20. Remove the shift tube downward through the column as follows: support the mast jacket on the edge of a wood block and drive against the inner end of the lower shift lever with a hammer and metal rod. Perform this operation carefully so that the shift lever is not bent or distorted.

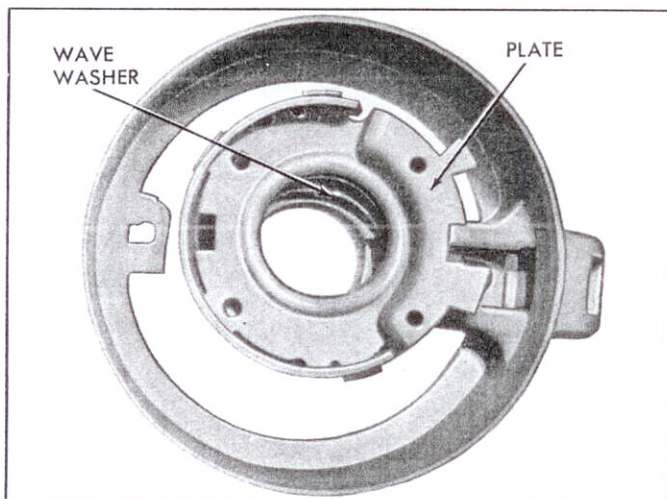

Fig. 15—Lock Plate, Wave Washer and Shift Lever Support Housing

21. Remove the lock plate, wave washer and selector lever support housing from the upper end of the mast jacket.
22. If desired, the selector lever pivot pin, lever and spring may be removed from the selector lever support housing.
23. Remove the mast jacket cover.

TILT WHEEL ACTUATOR DISASSEMBLY AND ASSEMBLY

Disassembly

Drive the lock shoe pins out of the actuator assembly and remove the shoes and springs.

NOTE: The upper shoe may be identified by the rubber bumper installed on it and by its three notches. There are four notches in the lower shoe.

The actuator assembly should be disassembled no further. The shoe release actuator and the turn signal bell crank must be serviced as part of the actuator assembly.

Assembly

1. To reassemble the lock shoes and springs, install the springs on the upper end, of the lock shoes, then install shoes in the actuator assembly and retain with the dowel pins.

NOTE: It is extremely important when reassembling the actuator assembly that the rubber bumper be installed in the upper lock shoe.

2. When reassembling the turn signal control cable to the bell crank, the cable loop should be inboard.
3. Install the cable bracket screw.

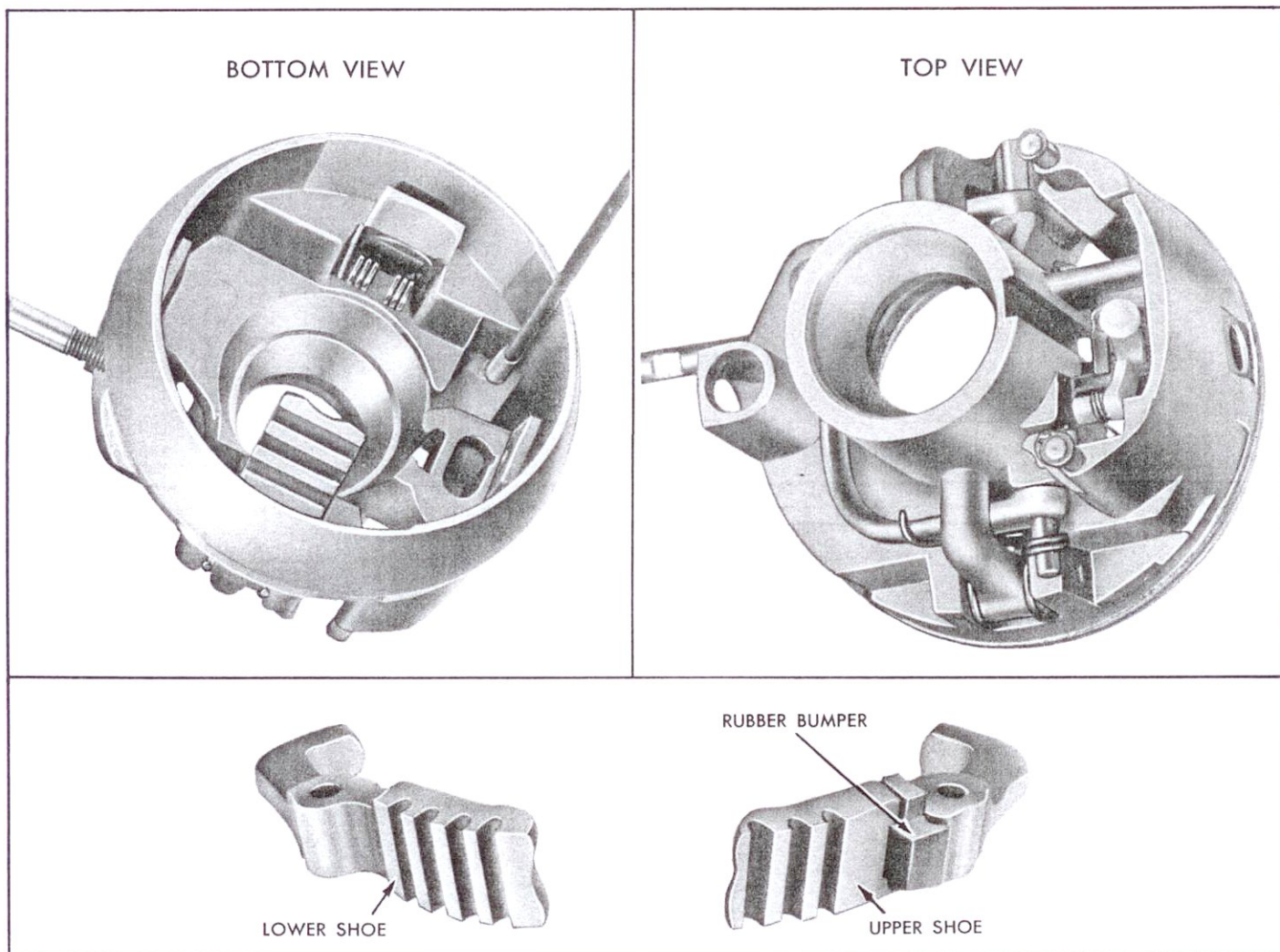

Fig. 16—Actuator Assembly

STEERING SHAFT DISASSEMBLY AND ASSEMBLY

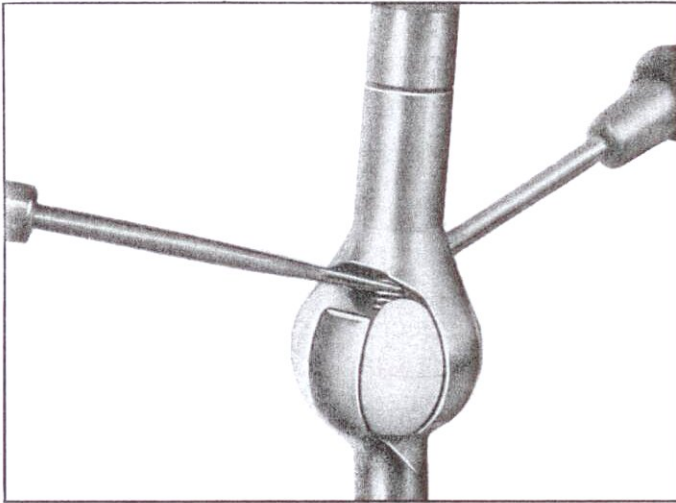

Fig. 17—Removing Preload Spring

Remove the spring from between the two halves of the steering shaft sphere as follows (being careful not to lose the spring which is under compression):

Disassembly

1. Turn the upper shaft slightly from the centerline of the lower shaft.
2. Using a narrow bladed screwdriver compress the spring enough to remove it from its seat in the upper shaft, then remove spring.

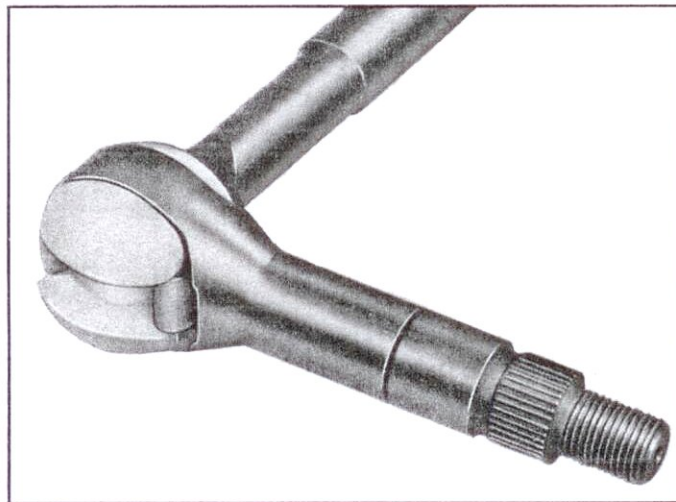

Fig. 18—Disassembly of Steering Shaft

3. Turn the upper shaft 90° from the centerline of the lower shaft and remove the shaft over the flats of the centering sphere.
4. Rotate spheres so the grooves align with the lower shaft socket and remove the spheres.

Assembly

5. Apply front wheel bearing lube to the centering spheres and the steering shaft sockets and place the spheres in the upper shaft socket.

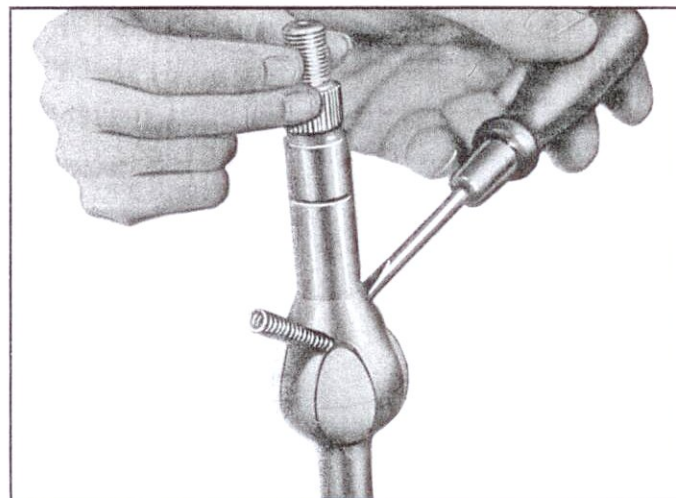

Fig. 19—Installing Preload Spring

6. Turn the spheres so the lower shaft may be installed over the grooves.

NOTE: The locating mark on the end of the upper shaft should be on the same side as the flat on the lower shaft.

7. Insert the joint preload spring through the spheres into the lower shaft. Then, using the upper shaft to hold the spring in place, carefully feed the spring into the upper shaft joint with a narrow bladed screwdriver.

ASSEMBLING THE TILT WHEEL STEERING COLUMN

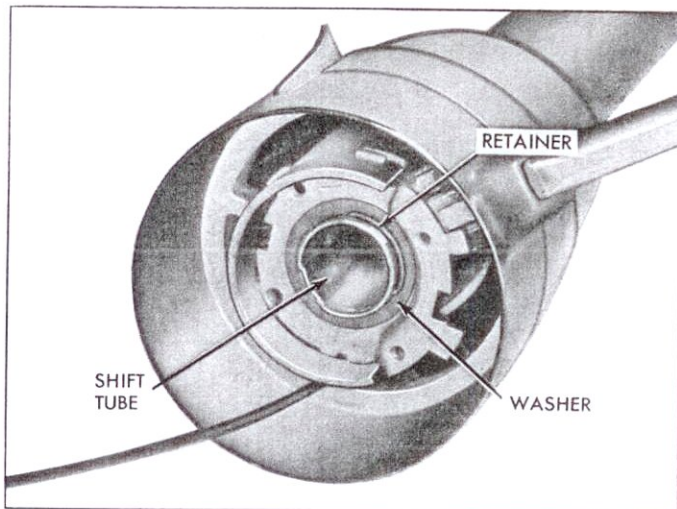

Fig. 20—Lock Plate Installed

When assembling the steering column apply a thin coating of bearing lube to all friction parts.

1. If removed, install the selector lever spring, lever and retaining pin.
2. Loosely install mast jacket cover and slide the lower seal assembly over the lower end of the mast jacket.
3. Install the selector lever support housing on the mast jacket, place the wave washer over the mast jacket and slide the lock plate into position so the tang on the locking plate engages the slot in the mast jacket.

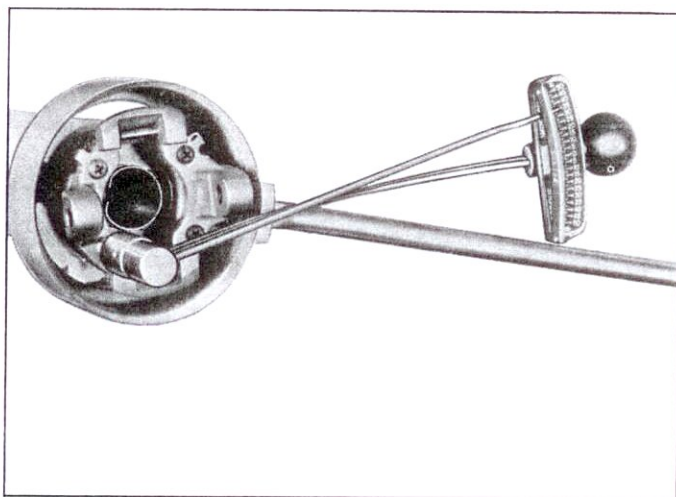

Fig. 21—Installing Actuator Support

4. Slide the shift tube assembly, felt seal in place, into the mast jacket from the lower end. With the shift tube properly lined up with the keyway in the support housing, tap shift tube into place. Install washer and retainer.
5. Install the actuator support on the upper end of the mast jacket. Torque attaching screws, larger (left hand) screws first, to 30-40 in. lbs.

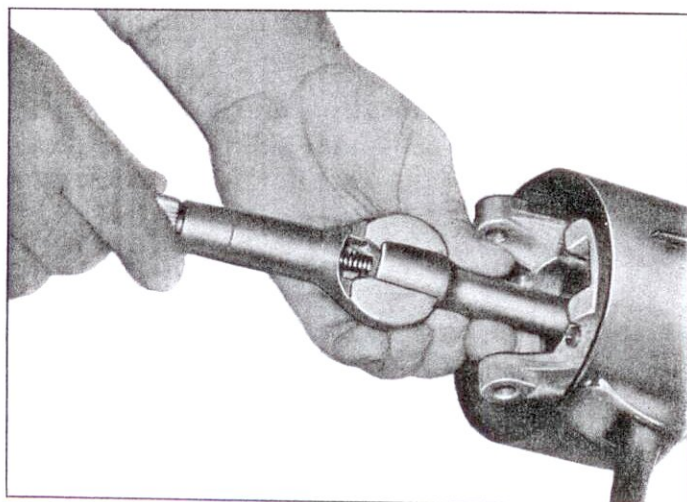

Fig. 22—Steering Shaft Installation

6. Install the steering shaft assembly into the upper end of the mast jacket.
7. At the lower end of the mast jacket install the lower bearing assembly carefully, taking care not to damage the bearing as it passes over the splines on the shaft.

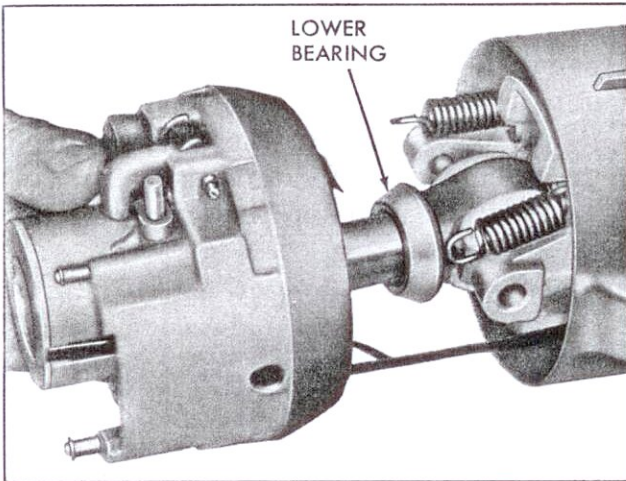

Fig. 23—Installing Actuator

8. Install the lower bearing on the upper shaft.
9. Place the horn contact assembly on the actuator assembly and insert wires through the actuator and into mast jacket along with the turn signal control cable.
10. Install two return springs in the support.
11. Install the tilt lever and, holding the lever back to prevent lock shoes from engaging the locking pins, install actuator carefully over shaft, then release lever.

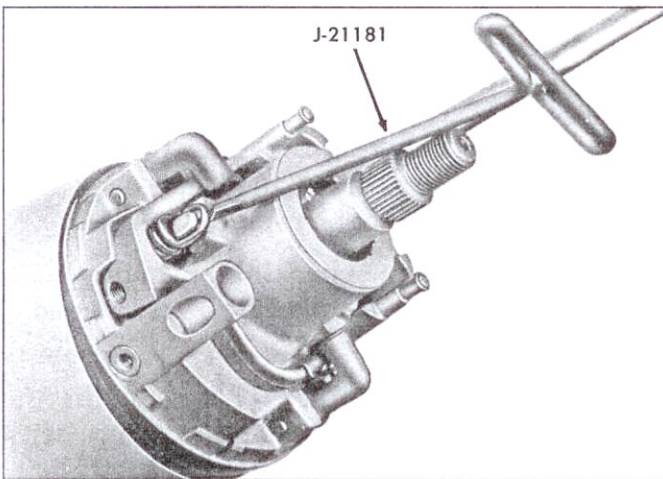

Fig. 24—Installing Return Springs

12. Align the actuator assembly pivot pin holes with the pin holes in the support assembly and install the pivot pins flush with the surface of the actuator assembly.
13. With the tilt wheel mechanism tilted fully "up," install the upper ends of the return springs on the actuator using Tool J-21181 and then set tilt wheel mechanism in center position.

NOTE: If the return springs were distorted during their removal it is best to discard them and reinstall new springs.

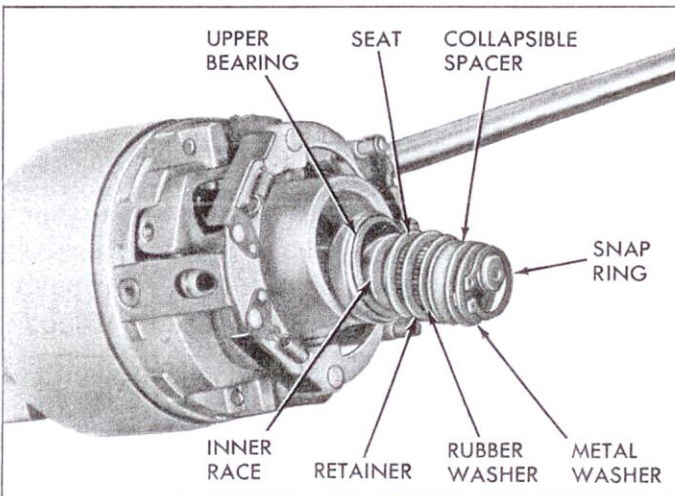

Fig. 25—Bearing Preload Parts

14. Pry out the horn contact assembly and allow it to hang free. Then install the steering shaft upper bearing, inner race, seat, retainer, rubber washer, a new collapsible spacer, washer, and, using snap ring pliers J-4880, install a new retainer ring over the steering shaft.

14 SERVICE PROCEDURES

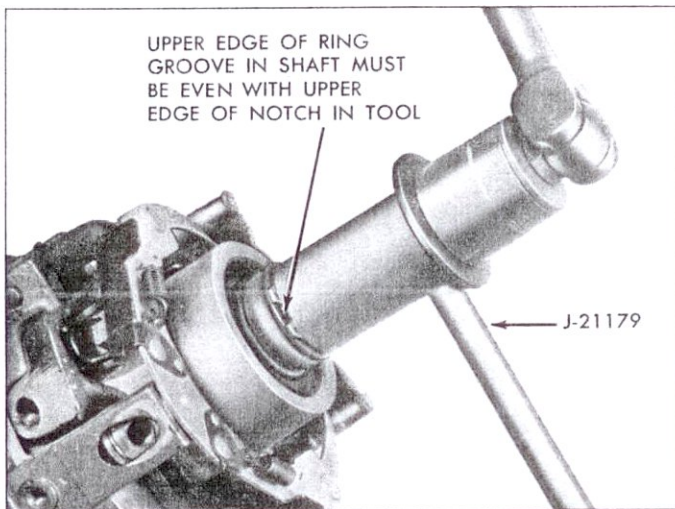

Fig. 26—Preloading Bearing

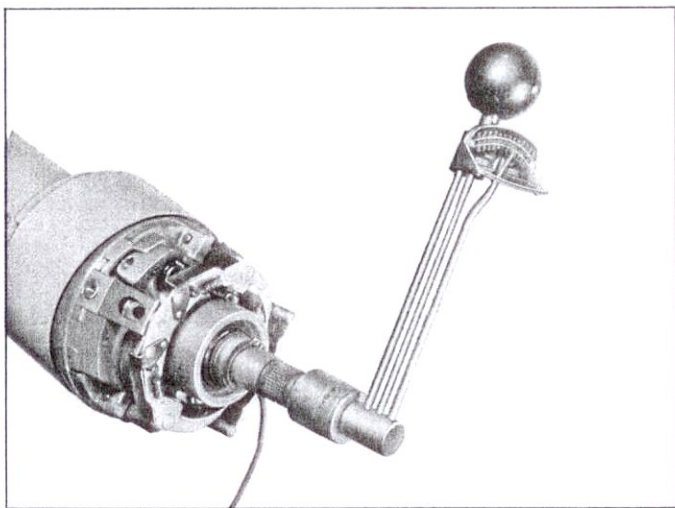

Fig. 27—Checking Steering Shaft Torque

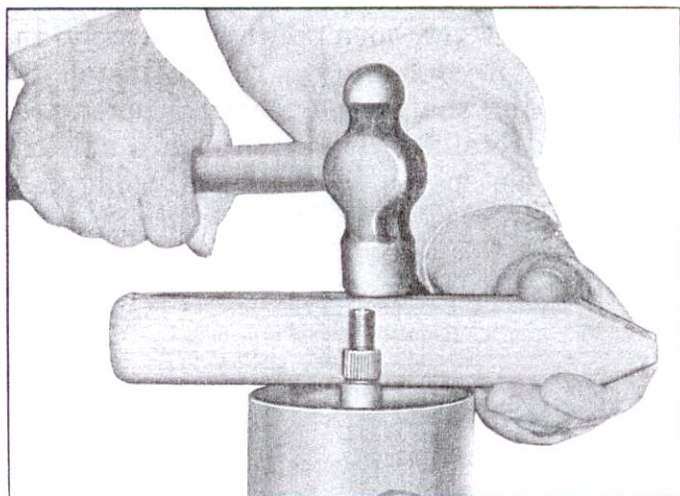

Fig. 28—Installing Turn Signal Cover

15. Place Tool J-21179 over the shaft and, using the steering wheel nut, turn down until the notch in the tool is in line with the upper edge of the retainer ring groove in the shaft. Remove the nut and Tool J-21179 and tap the snap ring into the groove.

16. Check the torque of the steering shaft in each tilt wheel position. Torque should be from 35-45 inch ounces. If the torque is too high repeat step 15, being careful to properly compress the spacer. If torque is too low the spacer has been over-compressed and must be replaced.

NOTE: When checking torque, the steering shaft must not be connected to the steering gear.

17. Seat the horn contact assembly in the actuator. Coat the contact ring with lubriplate or equivalent.

18. Install the turn signal yoke assembly and detent spring. Be sure the cable is attached to the bell crank (with the coil end toward bell crank) and that the other end of the bell crank is properly engaged in the yoke assembly bracket.

19. Remove the tilt release lever and, after aligning the turn signal cover properly, tap it into place using a block of wood.

20. Install the turn signal switch, the neutral safety switch and the backup light switch if present.

21. Install the turn signal lever and the tilt levers.

PART III

TROUBLES AND REMEDIES

Steering wheel loose— center position	<ul style="list-style-type: none"> a) Flange on spring seat is rolled over and washer retainer is cupped. b) Excessive clearance between holes in support and pivot pin diameter. c) Collapsible spacer retainer ring is unseated. 	<ul style="list-style-type: none"> a) Install new seat, retainer and collapsible spacer. b) Replace support and pivot pins. c) Replace collapsible spacer and retainer ring.
Steering wheel loose— every other position	<ul style="list-style-type: none"> a) If wheel is loose at the 5° and 15° positions either above or below center, the lower shoe is faulty. Looseness at 10°, either above or below center, indicates a faulty upper shoe. 	<ul style="list-style-type: none"> a) Install new shoe and pivot pin.
Wheel fails to return freely to top tilt position	<ul style="list-style-type: none"> a) Pivot pins bound up. b) Tilt springs defective. 	<ul style="list-style-type: none"> a) Remove pins and check for burrs. Install new pins. b) Replace tilt springs.
Noise when steering wheel returns to top tilt position	<ul style="list-style-type: none"> a) Tilt wheel stop on upper shoe has failed. 	<ul style="list-style-type: none"> a) Install upper shoe assembly.
Poor returnability of steering wheel	<ul style="list-style-type: none"> a) Deformed felt mast jacket seal. b) Too much bearing preload. 	<ul style="list-style-type: none"> a) Install new seal. b) Correctly adjust collapsible spacer.
Noise in gearshift mechanism	<ul style="list-style-type: none"> a) Wave washer damaged or omitted. b) Selector lever support housing driven too far on shift tube. 	<ul style="list-style-type: none"> a) Install new wave washer. b) Install new shift tube.

TROUBLES AND REMEDIES (Cont'd)

Noise in steering shaft	a) Column improperly aligned in car.	a) Relocate top pan cover on floor board, aligning steering shaft properly.
	b) Flange not tightened on shaft.	b) Torque flange to 25-35 ft. lbs.

Dust entering through column	a) Felt seal deformed or out of position.	a) Install new seal.
-------------------------------------	---	----------------------
