

# HEATERS AND AIR CONDITIONING

## CONTENTS

HEATERS .....	Page 1	AUTO-TEMP .....	Page 45
AIR CONDITIONING .....	7		

## HEATERS

### INDEX

General Information .....	Page 1	Heater Removal and Installation .....	Page 4
Service Diagnosis .....	3	Heater Core Removal and Installation .....	4
Service Procedure .....	3	Blower Motor .....	4
Control Cable Adjustment .....	3	Rear Seat Heater Removal and Installation .....	5

## GENERAL INFORMATION

Chrysler models use a "Blend Air" type heater (Fig. 1). Fresh air enters the heater through the cowl grille and passes through a plenum chamber to the heater core. A temperature control door in the heater plenum chamber directs the fresh air either through or past the heater core. The amount of "blend" is controlled by the setting of the temperature lever on the instrument panel. Direction of the "blended air" is controlled by the "Heat-Defrost" push buttons on the instrument panel.

Two doors, inside the heater assembly, are controlled by the "Heat" and "Defrost" buttons. When the "Heat" button is pressed the heater defroster door is closed and the heater shut-off door by the action of the vacuum actuator, is opened. When the "Defrost" button is pressed the heater shut-off door remains open and the heater defroster door, by the action of the vacuum actuator, is opened to route the heated air up to the windshield. The "Fan Switch" determines the speed of the heater blower motor.

The "Max" button will automatically put the heater in a high blower speed condition regardless of the position of the fan switch.

### Heating the Vehicle

For best heating results, the windows of the vehicle should be closed. When the green temperature indicator light goes "out", move the temperature control lever to the "warm" position. Push the "Heat" button and move the fan switch to "high." The temperature condition inside the vehicle can then be controlled using the "Fan Switch" and the "Temperature Control Lever."

### Summer Ventilation

Two air inlets are provided to allow outside air to be brought inside the vehicle in warm weather inde-

pendent of the heater. The control knobs for the inlets are located on the lower edge of the instrument panel on both sides of the steering column. **Be sure the air inlets are shut during cold weather.**

### Rear Seat Heater

A recirculating hot water rear seat heater mounted in the right side of the luggage compartment, is offered as optional equipment in all except convertible and station wagon models. A variable speed electric blower draws inside air through a duct mounted in the shelf panel behind the rear seat back and forces it through the heater core. From the heater core, warm air can be deflected either to the rear floor through ducts mounted under the rear seat cushion or through a defroster duct which is also mounted in the shelf panel.

The heater core is supplied with warm engine coolant from the front heater hoses by means of "tee" connections. A vacuum actuated valve controls the supply of coolant routed through steel tubing, under the right side of the floor pan, to the heater core.

Control consists of two toggle type switches mounted in the instrument panel. The right hand switch controls the heater blower motor speed. The other switch controls a vacuum actuated damper which directs the flow of air either to the defroster—defogger or floor heater ducts. This switch also controls coolant flow at the valve in the engine compartment.

### Heating the Vehicle

When the green temperature control indicator light goes "out" move the left hand toggle switch to either the defroster position or the heat position. The right hand switch controls the blower speed.

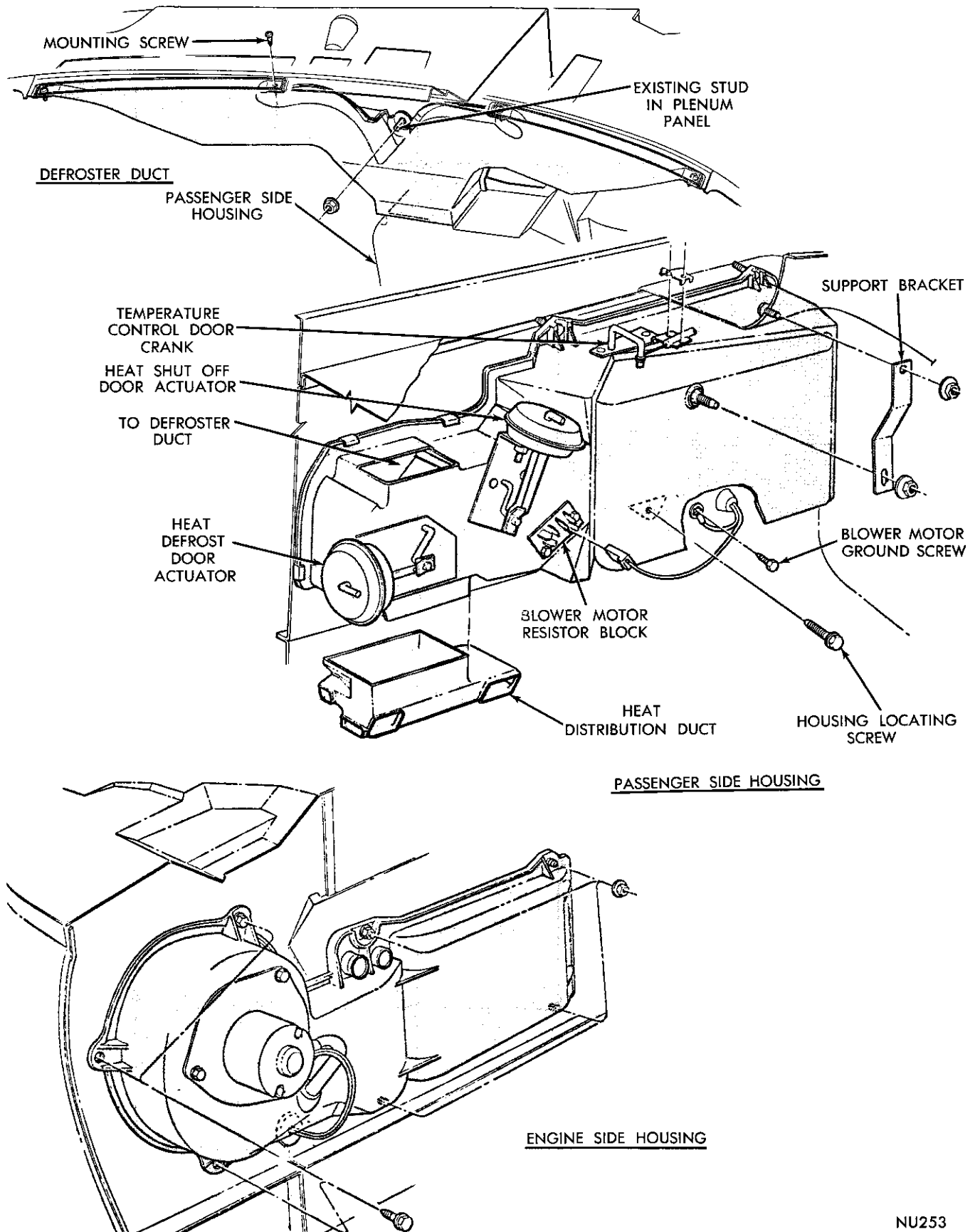


Fig. 1—Heater, Chrysler and Imperial

**Defogging the Rear Windows**

To defog the rear glass, place the left hand switch in the "Air" position. This will close the vacuum actuated water valve and cool air will flow to the rear glass. The blower switch will control the volume of air.

For summer operation, the heater control switch

should be kept in the "Air" position. This shuts off the coolant supply to the heater core and stops the natural flow of warm air through the heater ducts. With the control in the "Heat" or "Defrost" position, the coolant valve is open and coolant flows through the heater unit.

**SERVICE DIAGNOSIS**

Condition	Possible Cause	Correction
<b>INSUFFICIENT HEAT</b>	(a) Carpet obstructing outlet.	(a) Reposition carpet to uncover outlet.
	(b) Coolant level too low.	(b) Fill the radiator to recommended level.
	(c) Engine thermostat stuck open.	(c) Replace thermostat. See Group 7, "Cooling System".
	(d) Damaged vacuum line to shut-off damper.	(d) Replace vacuum line.
	(e) Obstructed heater hose.	(e) Replace heater hoses as necessary.
	(f) Radiator hoses leaking.	(f) Correct leaks and bleed cooling system.
	(g) Fresh air vent doors leaking.	(g) Adjust control cables.
	(h) Temperature control door leaking.	(h) Adjust control cable.
	(i) Kinked hoses.	(i) Reroute to eliminate restrictions.
<b>TOO MUCH HEAT</b>	(a) Disengaged cable.	(a) Connect or replace cable.
	(b) Thermostat stuck in closed position.	(b) Replace thermostat. See Group 7, "Cooling System".
<b>BLOWER MOTOR NOT OPERATING</b>	(a) Blown fuse.	(a) Check for excessive resistance in circuit and replace fuse.
	(b) Faulty electrical connection.	(b) Tighten all electrical connections.
	(c) Faulty blower switch.	(c) Replace switch.
	(d) Faulty motor.	(d) Replace motor.

**SERVICE PROCEDURES**

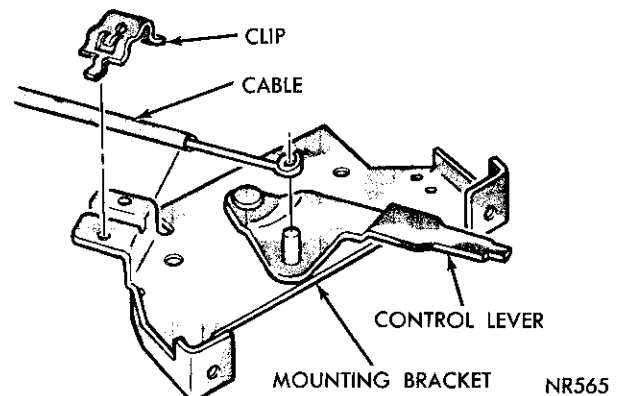
**CONTROL CABLE ADJUSTMENT**

- (1) Disconnect battery ground cable.
- (2) Remove ash receiver and housing (Chrysler only).
- (3) Remove vacuum control switch, temperature control bracket and lower assembly through ash receiver housing opening.
- (4) Remove glove box to provide access to the heater temperature door.
- (5) Disconnect temperature control cable at heater.
- (6) At heater control assembly, position cable housing to edge of cable bracket (Fig. 2) and install clip.
- (7) Install temperature control bracket and secure vacuum control switch in place on temperature control bracket.
- (8) Place temperature control arm in extreme left position and connect cable to temperature control door crank on heater assembly while holding door in extreme right position. Install clip.
- (9) Install ash receiver and housing assembly.
- (10) Connect battery ground cable and test operation of heater controls. For Heater Control and Switch

removal, see "Switches in Instrument Panels"—Group 8.

**Fresh Air Vent Control Cable Adjustment**

- (1) Push the fresh air control knob in (leave about 1/8 inch between the knob and panel).
- (2) Remove the kick pad at the fresh air outlet.
- (3) Remove the control cable clip from the vent door cable bracket.



**Fig. 2—Heater Control Cable Adjustment (Typical)**

- (4) Rotate and hold the vent door firmly closed and attach cable clip.
- (5) Reinstall kick pad.

## HEATER REMOVAL

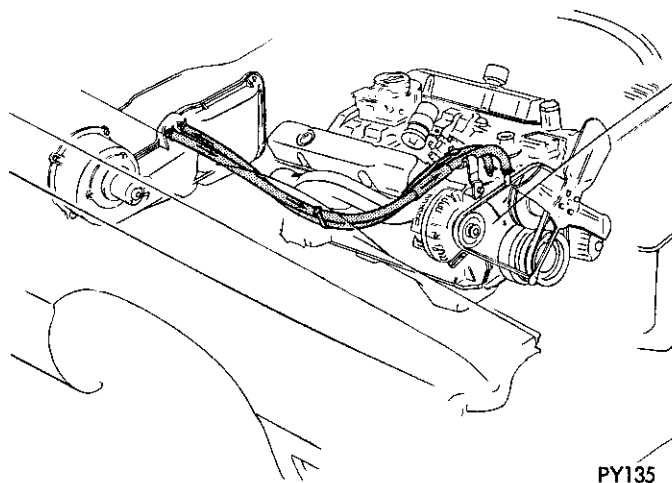
### Passenger Side Housing

- (1) Disconnect battery negative cable and drain radiator.
- (2) In engine compartment disconnect heater hoses at dash panel. Plug hose fittings on heater to prevent any coolant from spilling on inside of vehicle as heater assembly is removed.
- (3) Slide front seat back to allow room to remove unit from vehicle and unplug antenna lead from side of radio.
- (4) Remove vacuum hoses from trunk lock if so equipped.
- (5) Disconnect electrical connectors from blower motor resistor block on face of housing.
- (6) Remove two vacuum hoses from defroster actuator and two vacuum hoses from heater shut off door actuator.
- (7) Remove bottom retaining nut from support bracket and swing bracket up out of the way.
- (8) In engine compartment remove four retaining nuts from studs on engine side housing.
- (9) Remove locating bolt from bottom center of passenger side housing.
- (10) Roll or tip housing out from under instrument panel.
- (11) Remove temperature control cable retaining clip and cable from heat shut off door crank.

### Installation

**NOTE:** Before pressing housing to dash panel, be sure housing to panel seal is not misaligned or damaged.

- (1) Position housing on front floor of vehicle under instrument panel and place temperature control cable in bracket. Place end of cable housing flush with end of bracket and install retaining clip.
- (2) Tip housing up under instrument panel and press mounting studs through dash panel.
- (3) While holding housing in position, install locating screw. Then swing mounting bracket down onto stud on face of housing and install mounting nut.
- (4) In engine compartment install four retaining nuts and tighten securely. (24 inch-pounds).
- (5) Connect electrical connectors to resistor block and vacuum hoses to actuators (white hose to rod side of actuator).
- (6) Plug antenna lead into radio and connect vacuum trunk lock hoses if so equipped.
- (7) From engine compartment, remove plugs from core tubes and connect hoses to heater (Fig. 3).



**Fig. 3—Heater Hose Routing**

- (8) Fill cooling system and connect battery negative cable.
- (9) Start engine, operate heater and bleed air from system.

## HEATER CORE

### Removal

- (1) Remove passenger side housing from vehicle. (See Passenger Side Housing Removal).
- (2) From inside housing, remove two retaining nuts from right side of heater core and four screws from outside of housing.
- (3) Remove core tube locating metal screw from top of housing.
- (4) Carefully pull heater core out of housing.

### Installation

**NOTE:** Examine core to housing seal for damage or misalignment before seating heater core in housing.

- (1) Position core on studs in housing and install two retaining nuts.
- (2) Install four core retaining screws from outside of housing and one core tube locating screw in top left of housing. Tighten all nuts and screws securely. (24 inch-pounds).
- (3) Install housing under instrument panel. (See Passenger Side Housing Installation).

## BLOWER MOTOR

The blower motor is mounted to the engine side housing under the right front fender between the inner fender shield and the fender. The inner fender shield must be removed to service either the blower motor or engine side housing. See Group 23 "Body and Frame" of this manual for detailed illustrations.

### Heater Door Service

For service of the heater regulator door, heater de-

froster door or the heater fresh air door the heater must be removed from the vehicle and disassembled. Refer to "Heater Removal and Installation."

**Blower Motor Resistor Replacement**

- (1) From under instrument panel disconnect wiring at resistor.
- (2) Remove two screws that mount resistor to heater and remove resistor.
- (3) Position new or repaired resistor into opening in heater assembly and install the mounting screws.
- (4) Connect wiring to resistor.

**REAR SEAT HEATER**

**Removal**

- (1) From under the car, remove two heater hose clamps at the junction of the front and rear tube assembly and drain system (Fig. 5).
- (2) Remove rear seat cushion and back seat.
- (3) From inside car, remove two heater hose clamps and hoses from the heater.
- (4) Remove spare tire from luggage compartment.
- (5) Disconnect motor feed wire, fresh air intake hose and flexible blower discharge duct.
- (6) Remove the four metal screws from mounting brackets and remove heater to the bench for servicing (Fig. 4).

**Installation**

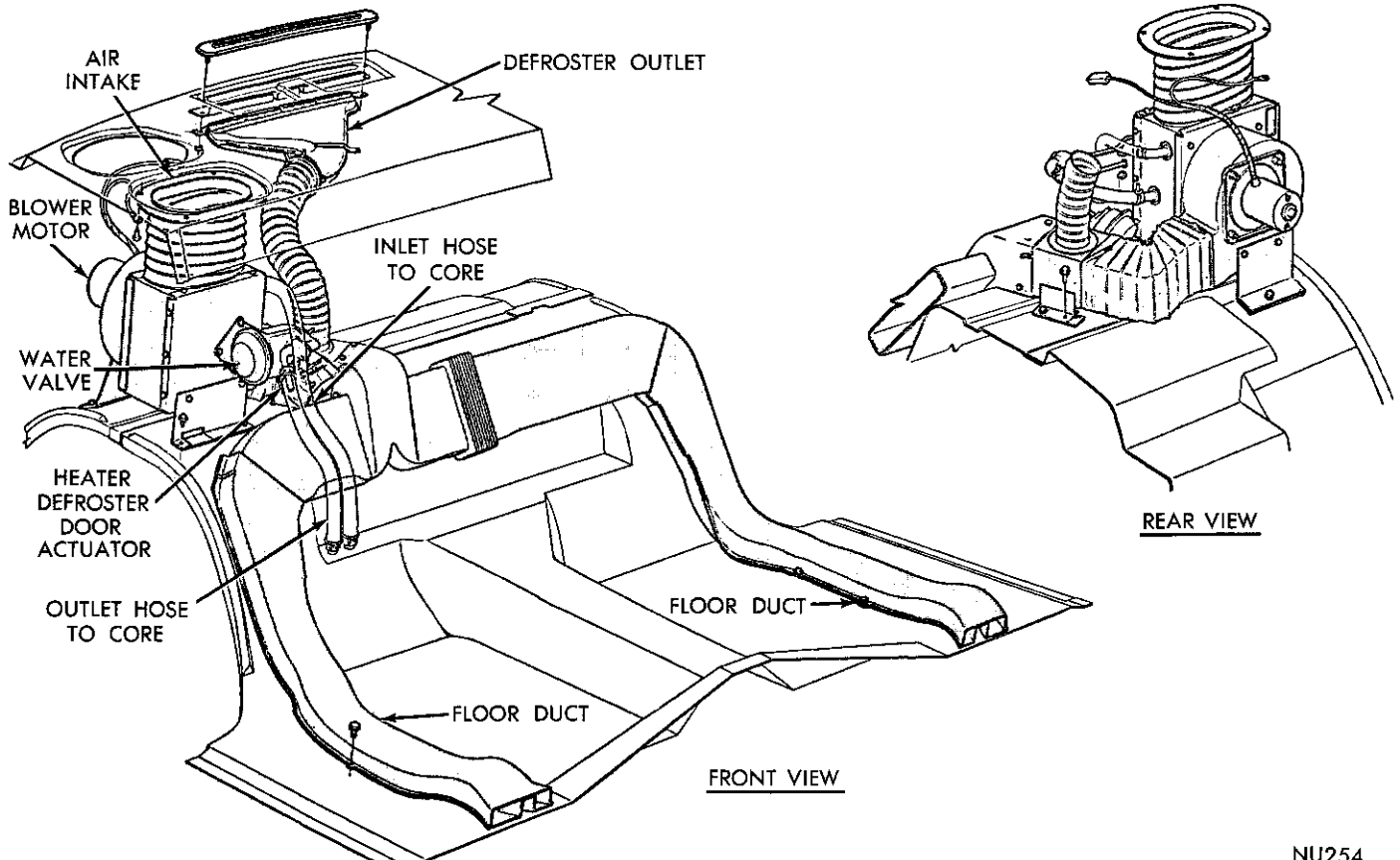
- (1) Position heater assembly in luggage compartment and install the four mounting screws in mounting bracket.
- Be sure to install motor ground wire terminal to the mounting screw under blower motor.**
- (2) Install blower discharge duct and air intake hose.
- (3) Inside car, install two heater hoses and clamps to heater.
- (4) Install spare tire.
- (5) Install two heater hoses at junction of tube assemblies.
- (6) Fill cooling system, start engine, bleed heater system of air and check for leaks.
- (7) Install seat back and rear seat cushion and heat shield.

**CAUTION: Carefully align the seat cushion to mate with floor mounted air ducts before locking seat in place. Misalignment will crush air ducts.**

**HEATER CORE**

**Removal**

- (1) Remove heater from vehicle as outlined in "Heater Removal."
- (2) Remove the 11 metal screws from end plate and remove plate.



**Fig. 4—Rear Seat Heater**

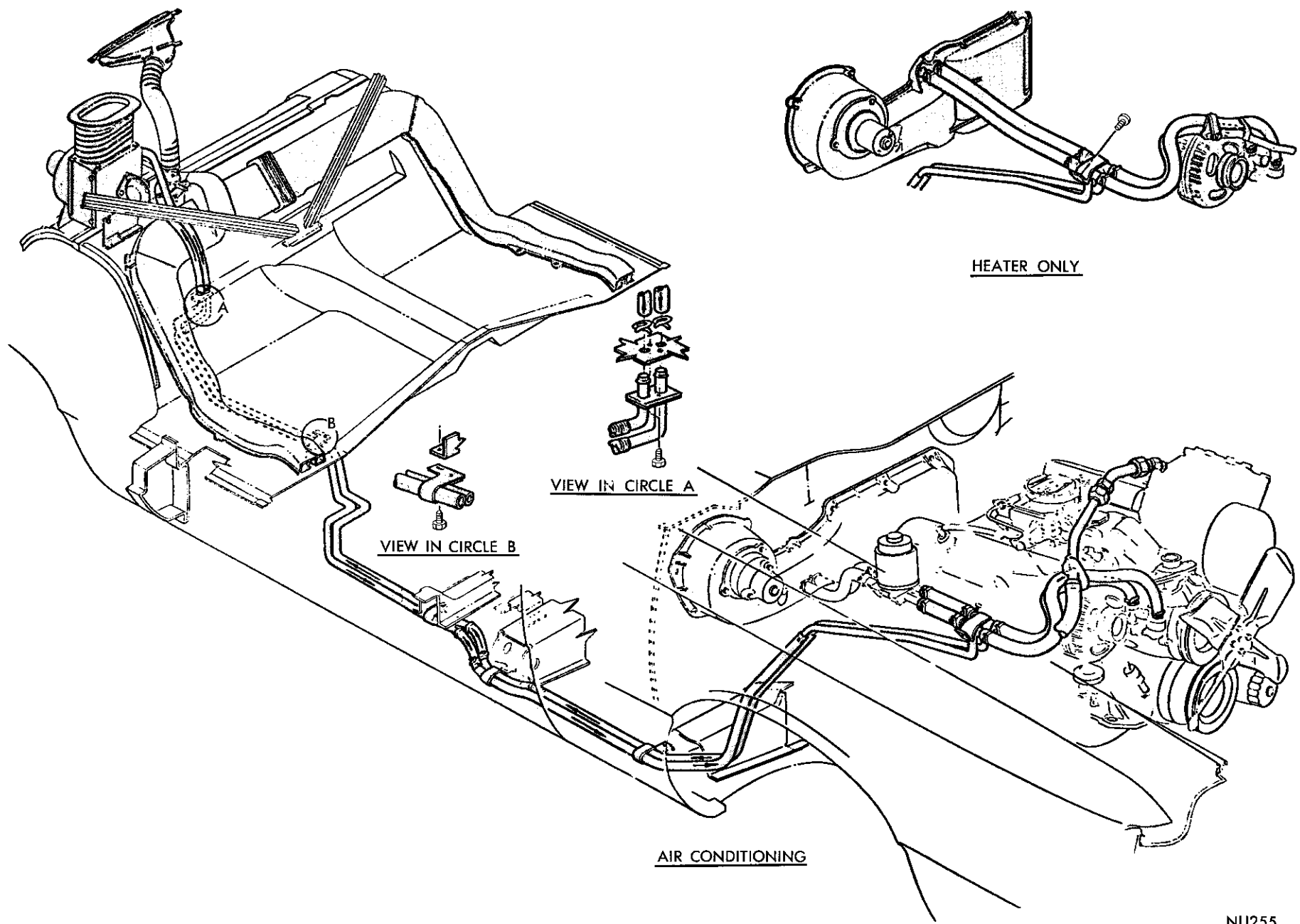


Fig. 5—Rear Seat Heater Hose Connections

(3) Remove the four screws retaining heater core to heater body and remove the core.

**Installation**

- (1) Position heater core in heater body and install the four retaining screws.
- (2) Install end plate and 11 metal screws.
- (3) Install heater as outlined in "Heater Installation."

**Blower Motor Rear Unit**

The heater blower motor can be replaced without removing heater from vehicle as follows:

- (1) Remove spare tire from luggage compartment.
- (2) Disconnect motor feed wire and ground wire from end mounting bracket screw.
- (3) Remove the four motor mounting plate nuts and remove motor assembly from the heater.
- (4) Loosen set screw mounting fan to shaft and slide fan from shaft.
- (5) Remove the two nuts from plate and separate motor from plate.

**Installation**

- (1) Install back plate on end of motor and secure with the two nuts.
- (2) Install fan on the motor shaft. Adjust for clearance of fan and heater chamber.
- (3) Install motor assembly in heater and the four mounting nuts.
- (4) Connect motor feed wire and install ground wire terminal under end mounting bracket screw.
- (5) Install spare tire in luggage compartment.

**Floor Air Ducts**

Replacement of the floor air ducts is accomplished by removing the seat back and seat cushion. The ducts are fastened to the floor pan with sheet metal screws. (Fig. 4).

**CAUTION: When installing the seat cushion, carefully align the seat cushion with the floor air ducts before locking seat cushion in place. Misalignment will crush the air ducts.**

**AIR CONDITIONING**

**INDEX**

	Page		Page
Auto-Temp .....	45	Operating Instructions For Owners .....	7
Complete System Discharge and Recharge .....	20	Service Procedures .....	24
Evaporator—Heater Assembly .....	34	Servicing the Compressor .....	27
Gauge Set Manifold Installation .....	8	Test Procedures .....	10

**OPERATING INSTRUCTIONS FOR OWNERS**

**Anti-Freeze Required for Summer Operation**

Air conditioned cars must be protected with a permanent type antifreeze during summer to +15°F. or lower to prevent the heater case from freezing. However, this protection does not provide sufficient corrosion inhibitors for the engine cooling system.

Summer protection to -15°F. will provide adequate inhibitors for protection of engine cooling system against corrosion. **Do not use the same anti-freeze for more than one year.**

**Fast Cool Down**

If the car has been parked in the hot sun, open the windows and drive the car for several minutes to expel the warm air, and at the same time:

- (1) Slide the temperature control lever to the "Off" position (far left).
- (2) Push the "MAX. A/C" button.
- (3) Move the fan switch to "High".
- (4) Adjust the four cooling outlet vanes to direct cooled air to the desired area to suit occupants wishes.
- (5) Close windows.

**Normal Cooling (Cooling with Fresh Air)**

When the desired amount of cooling is obtained with the "Max" button, you can continue cooling with fresh outside air for added comfort by pushing the "A/C" button and adjusting the fan switch to change fan blower speed. If less cooling is desired, move the fan switch lever to "Low" speed and readjust the cooling outlets for indirect cooling. For warmer air, move the temperature control lever to the right to the desired temperature.

**Cooling For Special Conditions**

The air conditioner provides maximum dehumidified air at the most comfortable weather conditions above 50°F.

During rainy or muggy weather, operate the system as usual, using the temperature control lever to clear the windows and provide interior comfort.

If the outside air is extremely humid or too warm for cooling with fresh air as previously described, push the "Max. A/C" button.

This method is also recommended when driving through areas which are extremely dusty or have objectionable odors.

**Operation in Traffic**

In extremely slow traffic, additional cooling may be required.

When pulling a trailer, when driving through heavy traffic at 10 to 15 mph. or when pulling up steep hills additional engine cooling may be required. If any or all of these situations are encountered, put the transmission in a lower gear. At stop lights and other stops put transmission in Neutral and increase engine speed.

**Radiator Cap**

Air conditioned vehicles must be equipped with a radiator cap having a holding pressure of 15 to 16 psi. Replace the radiator cap that does not test within these specifications with a cap that does.

**Condenser**

Inspect the condenser for obstructions for foreign matter. Clean if necessary.

Any obstructions to the free flow of air across the condenser will decrease heat dissipation from the condenser, decrease the efficiency of the condenser and, in turn, decrease the evaporator's efficiency. These conditions result in increasing the discharge pressure and horsepower load on the engine. The use of a bug screen is not recommended as it, too, will decrease the free flow of air.

Inspect the condenser for bent or damaged fins. The bent fins on the condenser deflect air flow across the bent portions, decreasing the condenser area.

**Bug Screens**

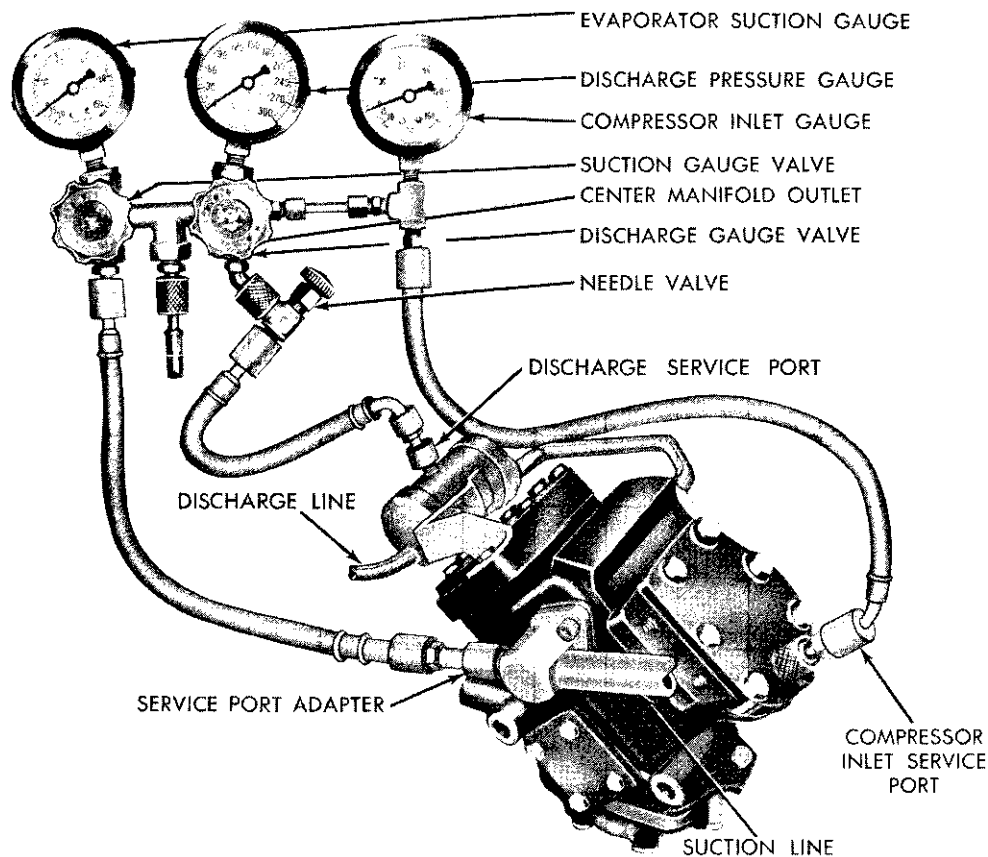
Bug screens should not be installed on vehicles equipped with air conditioner. A bug screen installed in front of the condenser will reduce air flow and effect air conditioner performance. Under severe heat conditions a bug screen may cause the engine to over-heat.

**THE GAUGE SET MANIFOLD INSTALLATION**

The Gauge Set Manifold is an indispensable test and diagnosis instrument. The gauge set manifold Tool C-3740 has two compound suction gauges and one discharge pressure gauge. Two accurately calibrated suction pressure gauges are required for the evaporator pressure regulator valve test. (Fig. 1).

The hoses are shown in the test illustrations for quick reference to distinguish the various adaptations.

**Evaporator Suction Gauge**—at the left side of the manifold set is calibrated to register 0 to 30 inches of vacuum and 0 to 150 psi. This gauge is connected to the suction service port of the compressor. A special service port adapter, supplied with the gauge set, provides the means of connecting the gauge set mani-



**Fig. 1—Gauge Set Manifold Connections**



fold hose to the service port. When the adapter is installed at the port and tightened, the stem of the valve in the service port is depressed, opening the service port valve.

**Discharge Pressure Gauge**—at the center of the manifold set is calibrated to register 0 to 300 psi. For all tests this gauge is connected to the discharge service port of the compressor. A service port adapter is used to make this connection. The needle valve, located below the discharge pressure gauge, is used to damp out gauge needle oscillations so that accurate readings can be obtained.

**Compressor Inlet Gauge**—is mounted at the right side of the manifold set. This mounting is for convenience only. There are no passages between this gauge and the gauge manifold. The compressor inlet gauge is calibrated to register 0 to 30" of vacuum and 0 to 150 psi. This gauge and the evaporator suction gauge must be accurately calibrated so that the needles of both gauges are exactly at 0 before making tests. The compressor inlet gauge is connected to the compressor inlet service port by a special service port adapter.

**This gauge is used, when checking the EPR Valve.**

**Center Manifold Outlet**—provides the necessary connection for a long service hose used when discharging the system, using a vacuum pump to "pull a vacuum" before charging the system, and for connecting the supply of refrigerant when charging the system.

**Manifold Gauge Valves**—should be closed when connecting the gauge set manifold to the service ports of the compressor. The suction gauge valve at the left is opened to provide a passage between the suction gauge and the center manifold outlet. The discharge gauge valve at the right is opened to provide a passage between the discharge pressure gauge and the center manifold outlet.

Detailed instructions for proper use of the gauge set manifold are contained in the test covering each test and service operation employing these gauges.

## SAFETY PRECAUTIONS

The refrigerant used in all air-conditioning installations is Refrigerant 12. It is transparent and colorless in both the liquid and vapor state. Since it has a boiling point of **21.7 degrees F. below zero** (at atmospheric pressure), it will be a vapor at all normal temperatures and pressures. The vapor is heavier than air, non-flammable and nonexplosive. It is non-poisonous except when it is in direct contact with open flame. It is noncorrosive except when combined with water. It is a safe refrigerant. The following precautions, however must be observed when handling Refrigerant 12.

**CAUTION: Wear safety goggles when servicing the refrigeration system.**

Refrigerant 12 evaporates so rapidly at normal atmospheric pressures and temperatures that it tends to freeze anything it contacts. For this reason, extreme care must be taken to prevent any liquid refrigerant from contacting the skin and especially the eyes.

Always wear safety goggles when servicing the refrigeration part of the air-conditioning system. Keep a bottle of sterile mineral oil and a weak solution of boric acid handy when working on the refrigeration system. Should any liquid refrigerant get into the eyes, use a few drops of mineral oil to wash them out. Refrigerant 12 is rapidly absorbed by the oil. Next, wash the eyes with the weak solution of boric acid. Call your doctor immediately even though irritation has ceased after first aid treatment.

**CAUTION: Do not heat Refrigerant 12 above 125 degrees F.**

In most instances, moderate heat is required to bring the pressure of the refrigerant in its container above the pressure of the system when charging or adding refrigerant. A bucket or large pan of hot water not over 125 degrees F. is all the heat required for this purpose. Do not heat the refrigerant container with a blow torch or any other means that would raise temperature and pressure above this temperature. Do not weld or steam clean on or near the system components or refrigerant lines.

**CAUTION: Keep Refrigerant 12 containers upright when charging the system.**

When metering Refrigerant 12 into the refrigeration system, keep the supply tank or cans in an upright position. If the refrigerant container is on its side or upside down, liquid refrigerant will enter the system and damage the compressor.

**CAUTION: Always work in a well-ventilated room.**

Always maintain good ventilation in the working area. Always discharge the refrigerant into the service bay exhaust system or outside the building. Large quantities of refrigerant vapor in a small, poorly ventilated room can displace the air and cause suffocation.

Although Refrigerant 12 vapor is normally non-poisonous, it can be changed into a very poisonous gas if allowed to come in contact with an open flame. Do not discharge large quantities of refrigerant in an area having an open flame. A poisonous gas is produced when using the flame-type leak detector. Avoid inhaling the fumes from the leak detector.

**CAUTION: Do not allow liquid refrigerant to touch bright metal.**

Refrigerant will tarnish bright metal and chrome surfaces. Avoid splashing refrigerant on any surface. Refrigerant in combination with moisture is very corrosive and can cause great damage to all metal surfaces.

**TEST PROCEDURES**

**INDEX**

Correcting Low Refrigerant Level .....	Page 12	Refrigerant Level .....	Page 10
Expansion Valve and EPR Valve Test .....	17	Roof Unit Performance Test .....	15
Expansion Valve Test (Dual Unit) .....	20	Testing System For Leaks .....	12
Front Unit Performance Test .....	14	Test System Pressure .....	10
Over-All Performance Test .....	14		

**TEST 1**

**TEST SYSTEM PRESSURE**

**(Engine not Running)**

Install the gauge set manifold. After tightening service port adapters, make sure that the needle valve located below the discharge pressure gauge is open. Purge air from the gauge hoses (Fig. 1) as follows:

- (1) Open suction gauge valve momentarily, then close it.
- (2) Open discharge gauge valve momentarily, then close it.
- (3) Loosen compressor inlet suction hose connection at the manifold momentarily, then tighten it.

If vehicle has been parked and the air conditioning system not operating, gauge pressure should be normal for temperature of the system. Refer to the Temperature-Pressure Relationship Chart.

If no pressure is indicated on the gauges it means that the system is empty, due to a leak. It will be necessary to evacuate, charge with a sweep-test charge, locate and correct the leak, purge the test charge, replace the drier, vacuum the system and charge the system with the proper amount of Refrigerant 12.

erant 12.

If pressures are normal, proceed with the next test and adjustment.

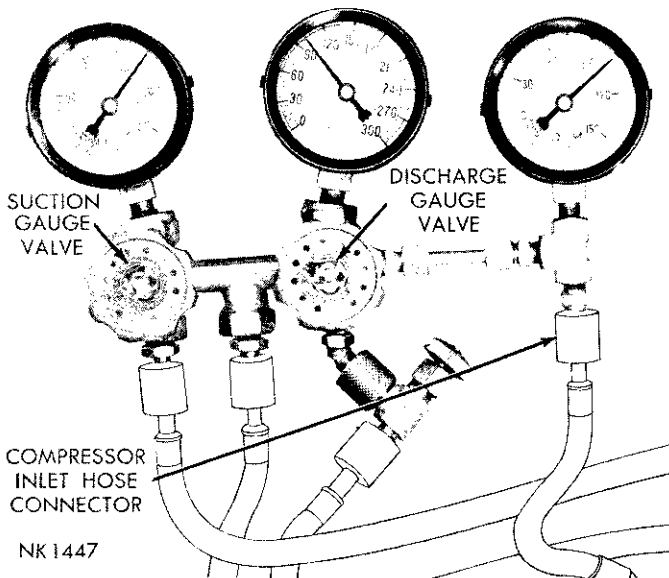
**TEST 2**

**REFRIGERANT LEVEL**

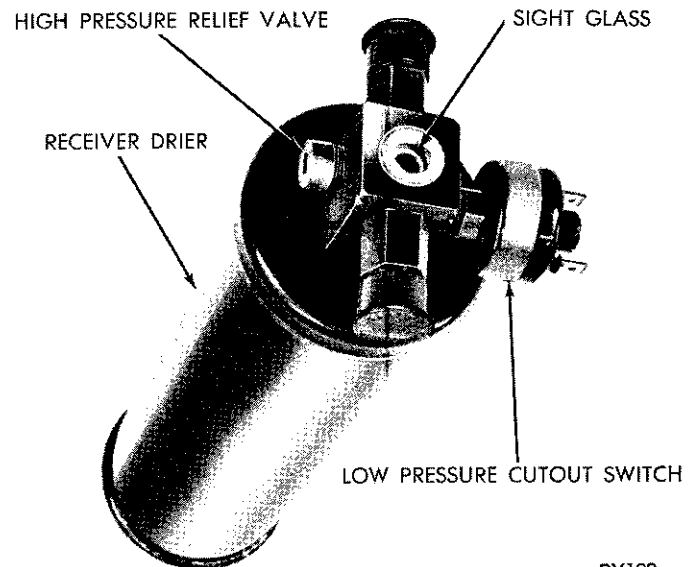
The system must be operated at high blower speed, with vehicle doors and windows open, if the system is a dual system, both units must be operated simultaneously at high blower speed when this test is made, and when adding to the charge.

The sight glass is an integral part of the receiver-strainer-drier. The outlet line (liquid) from the condenser must be attached to the connection marked IN. The word IN is stamped on the top face of the inlet connection (Fig. 2). If the receiver-strainer-drier is reversed and the lines are connected wrong, the system must be purged, the lines reversed and the system recharged.

Block the air flow across the condenser to raise the discharge pressure to 225 to 250 psi, and check the sight glass for foam. There should be no foam. If sight glass is clear, remove the air restriction from the condenser and allow the discharge pressure to return to normal.



**Fig. 1—Purge Gauge Hoses**



**Fig. 2—Receiver Drier**

**TEMPERATURE-PRESSURE RELATIONSHIP CHART  
(FOR REFRIGERANT 12)**

Temp. F.	Press. PSI	Temp. F.	Press. PSI	Temp. F.	Press. PSI	Temp. F.	Press. PSI	Temp. F.	Press. PSI
0	9.2	35	32.6	60	57.7	85	91.8	110	136.4
2	10.2	36	33.4	61	58.9	86	93.3	111	138.4
4	11.2	37	34.3	62	60.1	87	94.7	112	140.5
6	12.0	38	35.2	63	61.3	88	96.5	113	142.6
8	13.5	39	36.1	64	62.5	89	98.2	114	144.7
10	14.6	40	37.0	65	63.8	90	99.8	115	146.8
12	15.8	41	37.9	66	65.0	91	101.5	116	148.9
14	17.1	42	38.9	67	66.3	92	103.1	117	151.1
16	18.4	43	39.8	68	67.6	93	104.8	118	153.2
18	19.7	44	40.7	69	68.9	94	106.5	119	155.4
20	21.0	45	41.7	70	70.2	95	108.3	120	157.7
21	21.7	46	42.7	71	71.5	96	110.0	121	159.9
22	22.4	47	43.6	72	72.9	97	111.7	122	161.2
23	23.2	48	44.7	73	74.2	98	113.5	123	164.4
24	23.9	49	45.7	74	75.6	99	115.3	124	166.7
25	24.6	50	46.7	75	77.0	100	117.2	125	169.1
26	25.4	51	47.7	76	78.4	101	119.0	126	171.4
27	26.1	52	48.8	77	79.8	102	120.9	127	173.8
28	26.9	53	49.9	78	81.3	103	122.7	128	176.2
29	27.7	54	51.0	79	82.7	104	124.6	129	178.6
30	28.5	55	52.5	80	84.2	105	126.6	130	181.0
31	29.3	56	53.2	81	85.7	106	128.5	131	183.5
32	30.1	57	54.3	82	87.2	107	130.4	132	185.9
33	30.9	58	55.4	83	88.7	108	132.4	133	188.5
34	31.7	59	56.6	84	90.2	109	134.4	134	191.0

If the foam shows in the sight glass when the discharge pressure is 225 to 250 psi, it indicates the system is low on refrigerant. The proper amount of refrigerant required to complete a full charge may be added to the system as follows: Maintaining the discharge pressure at 225 to 250 psi, add refrigerant gas through the suction side of the system until foam is cleared from sight glass, then add exactly one-half (1/2) pound of refrigerant.

**Low Pressure Cut Out Switch**

The Low Pressure Cut-Out switch, which is located on the receiver drier, is wired in series with the compressor magnetic clutch. It cuts off the electrical power supply to the clutch when liquid refrigerant pressure drops to the control point of the switch. (Fig. 2).

The switch is a sealed, factory calibrated unit. No attempt shall be made to adjust or otherwise repair it. If it is found to be defective it must be replaced.

**Switch Test (Engine not running)**

- (1) Remove the two wires from the low pressure cut-out switch and connect them together.
- (2) Press the A/C button.
- (3) Momentarily turn the ignition switch on (**do not**

**crank the engine**), listen for the compressor clutch engaging.

(4) If the clutch does not engage, the clutch, wiring or fuse may be defective. Check the clutch circuit and clutch.

(5) If the clutch engages, connect the manifold gauge set and read the discharge pressure. At any pressure of 40 psi and above, the switch must actuate the clutch.

(6) Reconnect the wires to the switch and perform step number 3.

If clutch does not engage, discharge the system, replace the switch, check compressor oil level, and recharge the system.

**NOTE: Check compressor oil level before charging the system in accordance with instructions under "Oil Level—Compressor". If the pressure is below 40 psi the system may be low of charge. In this case it is mandatory to follow the procedure described below:**

(1) Add partial charge until the pressure gauge reads 40 psi.

(2) Perform step number 3 (wires connected to switch). If the clutch engages, the switch is satisfactory; if it does not, it must be replaced. In either case the following steps must be performed:

- (a) Check the system for leaks and repair as necessary.
- (b) Discharge the system. **Check the compressor oil level.** Replace the switch if it was found defective and recharge the system.

**NOTE:** Whenever the system is inactivated by the low pressure cut-out switch due to the loss of refrigerant, refrigerant oil may also have been lost. Therefore, to prevent damage to the compressor due to operation without sufficient lubrication, the leak must be repaired and the compressor oil level checked before final charge of the system in accordance with instructions under "Oil Level—Compressor".

### **High Pressure Relief Valve**

The High Pressure Relief Valve is located on the receiver drier opposite the low pressure cut-out switch. Its function is to prevent damage to the air conditioning system in the event that excessive pressure develops due to condenser air flow being restricted by, for example, leaves, newspaper, or an overcharge of refrigerant.

**NOTE:** The high pressure relief valve differs from the fusible plug in that it vents only the small amount of refrigerant necessary to reduce system pressure and then reseats itself. The majority of the refrigerant is conserved in the system. The valve is calibrated to vent at a pressure of 475 to 550 psi. therefore, the fact that the valve vented refrigerant, does not mean the valve is defective. The valve is part of the receiver drier assembly and must not be removed nor otherwise disturbed.

A mylar disc protects the venting ports of the valve and must not be removed, perforated, or otherwise damaged. The disc is intended to prevent humidity and salt from entering the valve mechanism. A valve in which the protective disc does not seal the venting port shall be repaired by removing the old protective disc and cleaning the surface of the valve so it will be free of oil, grease or other substances. Apply a disc cut from adhesive mylar, or "Scotch" type tape. Be sure that the disc covers the venting port. **Avoid the use of masking tape or electrical insulation tape.**

## **TEST 3**

### **TESTING THE SYSTEM FOR LEAKS**

The Leak Detector Torch Tool C-3569 is a propane gas-burning torch used to locate a leak in any part of the refrigeration system. Refrigerant gas drawn into the sampling or "sniffer" tube will cause the flame to change color in proportion to the size of the leak. A very small leak will produce a flame varying from yellowish-green to bright green. A large leak will produce a brilliant blue flame.

**CAUTION:** Do not use the lighted detector in any place where explosive gases, dust or vapors are present.

Do not breathe the fumes that are produced by the burning of refrigerant gas. Large concentrations of refrigerant in the presence of a live flame become dangerously toxic. Observe the flame through the window of the burner shield, not through the top of the shield.

If the flame remains bright yellow when the tester is removed from possible leak point, insufficient air is being drawn in through the sampling tube, or the reaction plate is dirty.

(1) Open the torch valve until you hear a faint hiss of escaping gas. Light the test torch and adjust the valve until the flame is very small. A small flame will detect large as well as small leaks, whereas a large flame will detect only large leaks. As soon as the reaction plate seen through the window in the burner shield becomes red hot, the tester is ready for use.

(2) Examine all tube connectors and other possible leak points by moving the end of the sampling hose from point to point. Since Refrigerant 12 is heavier than air, it is good practice to place the open end of the sampling hose directly below the point being tested. Be careful not to pinch the sampling tube since this will shut off the air supply to the flame and cause a color change.

(3) Watch for a change in the color of the flame. Small leaks will produce a green color and large leaks a bright blue color. If leaks are observed at tube fittings, tighten the connection, using the proper flare wrenches, and retest.

### **Remove Sweep-Test Charge**

If the system is free of leaks; or after correcting a leak, and if no air conditioning components have been removed, add the necessary refrigerant as described under TEST 4 "Correcting Low Refrigerant Level." If any parts of the refrigerant system were disconnected, remove the sweep test charge. Close the refrigerant manifold valve so that any refrigerant remaining in the container is sealed. Remove the long test hose from the refrigerant manifold. Insert the free end of this test hose into an exhaust system outlet. Open the right-hand gauge set manifold valve a fraction of a turn to let the sweep-test charge escape slowly. Allow the system to discharge until the discharge pressure gauge registers zero. Open the left-hand gauge valve to allow any refrigerant trapped in the suction side of the system to escape.

## **TEST 4**

### **CORRECTING LOW REFRIGERANT LEVEL**

Since the refrigeration system is completely sealed,

refrigerant level will not be low unless there is a leak in the system or refrigerant has been allowed to escape by depressing one of the service port valves. For detailed instructions on the proper procedure for checking refrigerant level, refer to "Refrigerant Level," TEST 2.

Before adding refrigerant where cause of low level is not known, the system should be tested for leaks. Assuming no leaks are present, or that leaks have been corrected without discharging the system, proceed with partial charge.

Install and connect gauge set manifold (Fig. 3).

(1) Close both of the gauge set manifold valves. Open the gauge set manifold needle valve.

(2) Connect the suction gauge test hose to the suction service port of the compressor.

On all models connect the discharge gauge test hose to the discharge service port of compressor.

(3) Connect one end of long test hose to center manifold outlet, other end to refrigerant dispensing manifold.

(4) Close two of the dispensing manifold valves and open remaining dispensing manifold valve. Remove protective cap from opened valve.

(5) Screw a can of Refrigerant 12 to the opened manifold valve. Be sure gasket is in place and in good condition. Tighten refrigerant can and manifold lock-

ing nut to insure a good seal. Do not over-tighten since 6 to 8 foot-pounds is sufficient if gasket is in good condition.

(6) Turn manifold valve (above the refrigerant can) completely clockwise to puncture the can. This closes the valve and seals the refrigerant in the can.

(7) Place the refrigerant in a large pan of water heated to 125°F. Place pan of water containing the refrigerant can on an accurate scale so that the amount of refrigerant added can be weighed. Open the refrigerant manifold valve.

(8) Purge all air from test hoses. Air in the system will be trapped in the condenser causing abnormally high discharge pressures and interfering with condensation of the refrigerant.

(9) Loosen both test hoses at the gauge set manifold. Tighten the hoses as soon as the air is purged.

(10) Loosen charging hose connection at gauge set manifold. This will purge air from the charging hose. Tighten connection as soon as air is purged.

(11) With vehicle windows open and hood up, operate engine at 1300 rpm.

(12) Push in "A/C" button, fan switch on high. On dual installation both blowers must be on high speed during charging operation.

(13) If necessary, block the condenser to maintain a discharge pressure of 225 to 250 psi. The system must

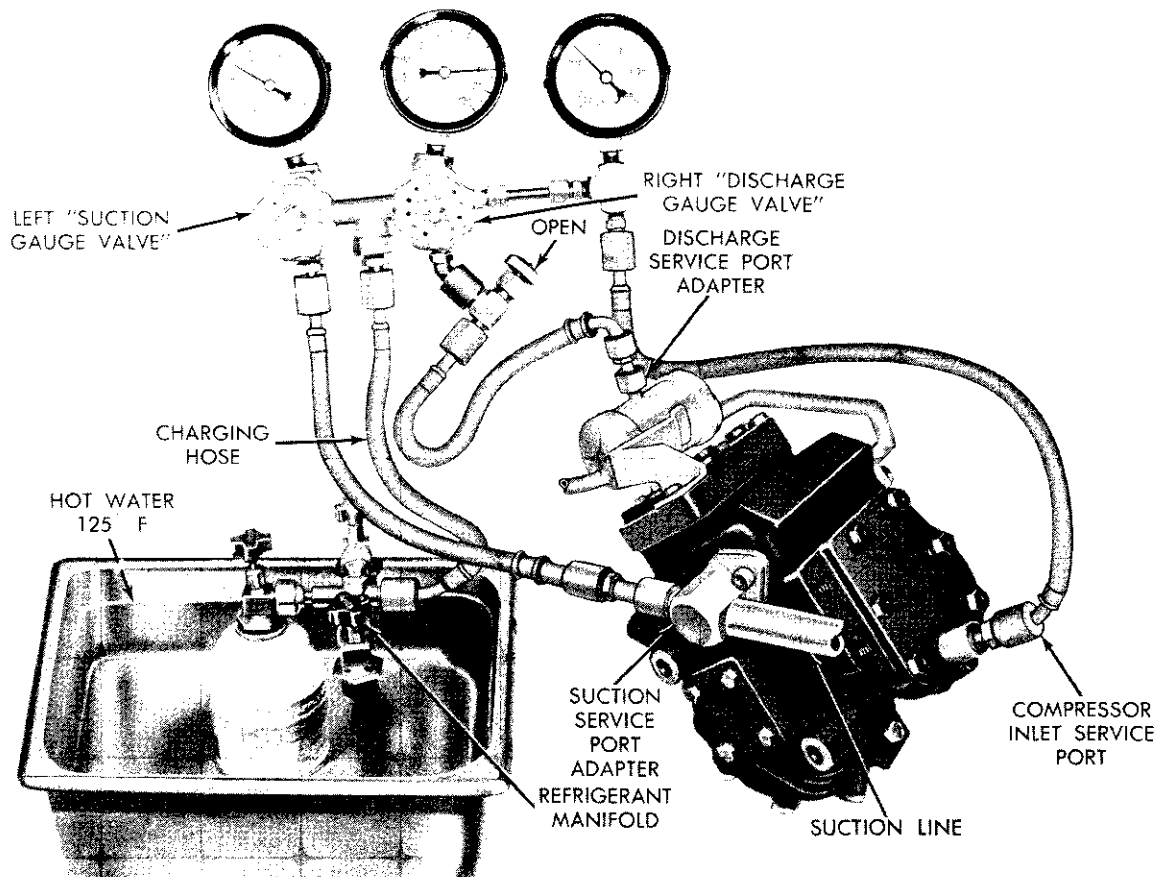


Fig. 3—Adding Partial Refrigerant Charge

be charged through the evaporator suction service port as follows:

(a) Slowly open the suction service gauge valve. Meter flow of refrigerant by adjusting the suction service gauge valve so that pressure registered at the suction service gauge does not exceed 50 psi. **Keep refrigerant container upright.**

(b) Add refrigerant gas until there is no foam visible at the sight glass. As soon as all foam clears, note the weight registered on the refrigerant scale.

(c) Watch the refrigerant weighing scale and add **exactly 1/2 pound more refrigerant to the system.** Close the suction gauge valve. **Too much refrigerant in the system can cause abnormally high discharge pressures. Care must be used so that exactly 1/2 pound of refrigerant is added after foam clears in the sight glass.**

(d) Close dispensing manifold valve. Remove test hoses and adapters from the service ports of compressor, and install protective caps at service ports.

## TEST 5

### OVER-ALL PERFORMANCE TEST

Humidity (the amount of moisture in the air) has an important bearing on the temperature of the air delivered to the vehicle's interior. This is true of all air-conditioned systems whether in the home, office or vehicle. It is important to understand the effect humidity has on the performance of the system. When humidity is high, the evaporator has to perform a double duty. It must lower the air temperature and the temperature of the moisture carried in the air. Condensing the moisture in the air transfers a great deal of heat energy into the evaporator fins and tubing. This reduces the amount of heat the evaporator can absorb from the air. In other words, high humidity greatly reduces the evaporator's ability to lower the temperature of the air delivered to the vehicle interior.

Evaporator capacity used to reduce the amount of moisture in the air is not wasted. Wringing some of the moisture out of the air entering the vehicle adds materially to the comfort of the passengers. However, an owner may expect too much from his air-conditioning system on humid days. A performance test is the best way to determine whether or not the system is performing up to standard. This test also provides valuable clues to the possible cause of trouble.

The preliminary inspections in TESTS 1 thru 4, outlined previously, should be made before the "Over-All Performance Test." Install gauge set manifold. **Air temperature in test room must be 75°F. minimum for this test.**

### FRONT UNIT PERFORMANCE TEST

(1) Start the engine, open the windows, temperature control lever must be in the off position.

(2) Push in "A/C" button, fan switch on high. Open all grille outlets.

**When testing the front unit of a dual system, leave roof unit blower turned off.**

(3) Adjust engine to 1300 rpm.

(4) Arrange gauge set manifold hoses and tachometer leads to allow hood to be lowered, then close hood.

(5) Place motor-driven psychrometer Tool C-3704 at cowl inlet opening. Distilled water should be used with this meter to prevent drying out and hardening the wet sock.

(6) Place thermometer Tool C-3623 fully into right outlet grille opening. The left outlet should be fully extended and directed towards rear of vehicle.

(7) Operate the air-conditioning system until a stabilized condition on the gauges and thermometers has been established. One of the most important steps in making the over-all performance test is that the engine must be operated at 1300 rpm for approximately five minutes to allow all the under-hood components of the system to reach their operating temperature.

(8) **Partially** close the needle valve, located below the discharge pressure gauge, to minimize oscillation of the pointer. Do not close the needle valve completely since this would prevent the discharge pressure gauge from registering pressure.

This test should be performed with the discharge pressure from 190 to 210 psi. The 190 to 210 pound pressure is for **test purposes only.** To increase pressure restrict the air flow across the condenser using cardboard, or paper, to decrease pressure, increase air flow across condenser with external floor fans.

(9) Observe and record the "Inlet Dry Bulb Temperature" and "Inlet Wet Bulb Temperature" as registered on the psychrometer.

Observe and record "Discharge Air Temperature" registered by thermometer at right hand grille outlet.

From the appropriate "Performance Temperature Chart," for vehicle and type installation being tested (Figs. 4 thru 10), determine the maximum allowable discharge air temperature for the prevailing "Dry" and "Wet" bulb temperatures recorded. If the vehicle's discharge air temperature is at or below the temperature given on the Performance Chart, the air-conditioning is delivering its cooling capacity. However, to assure trouble-free operation, continue with the "Expansion Valve and Evaporator Pressure Regulator Valve Test."

If discharge air temperature at the outlet grilles is above the maximum allowable on Performance Chart, perform the "Expansion Valve and Evaporator Pressure Regulator Valve Test."

SINGLE UNIT																																			
INLET AIR WET BULB TEMPERATURE																																			
55	56	57	58	59	60	61	62	63	64	65	66	67	68	69	70	71	72	73	74	75	76	77	78	79	80	81	82	83	84	85	86	87	88	89	90
41	42	43	44	45	46	47	48	49	50	50	50	51	51	52	52	53	53	53	54	54	55	56	57	58	59	59	60	62	64	66	67	68	69	70	71
DISCHARGE AIR DRY BULB TEMPERATURE																																			
INLET AIR DRY BULB TEMPERATURE MUST BE BETWEEN 75° AND 110°F																												NK1342 A							

**Fig. 4—Performance Temperature Chart—Front Unit Only**

FRONT UNIT OF DUAL																																			
INLET AIR WET BULB TEMPERATURE																																			
55	56	57	58	59	60	61	62	63	64	65	66	67	68	69	70	71	72	73	74	75	76	77	78	79	80	81	82	83	84	85	86	87	88	89	90
43	44	45	46	47	48	49	50	51	52	52	52	53	53	54	54	55	55	55	56	56	57	58	59	60	61	61	62	64	66	68	69	70	71	72	73
DISCHARGE AIR DRY BULB TEMPERATURE																																			
INLET AIR DRY BULB TEMPERATURE MUST BE BETWEEN 75° AND 110°F																												NK1343A							

**Fig. 5—Performance Temperature Chart—Front of Dual System**

**ROOF UNIT PERFORMANCE TEST**

The method used to test the roof unit of a dual installation is essentially the same as for a front unit. The front unit should be tested before testing the roof unit. Turn the front unit off by pushing the "OFF" button.

(1) Connect a jumper from the positive terminal of the battery to the compressor so that the refrigera-

tion part of the entire system can be operated without air-flow through the front unit.

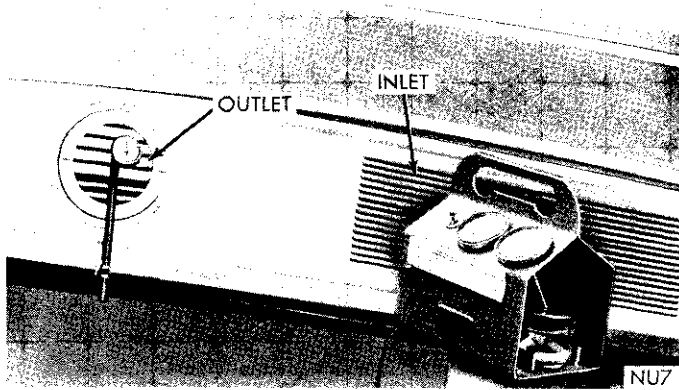
(2) Open the windows, adjust engine speed to 1300 rpm and close the hood. Turn roof unit blower motor switch to "high" speed position.

(3) Place motor-driven psychrometer Tool C-3704 near roof unit air outlet grille and a thermometer Tool C-3623 in right-hand air outlet grille (Fig. 7).

(4) Operate the air-conditioning system until a

ROOF UNIT OF DUAL																																			
INLET AIR WET BULB TEMPERATURE																																			
55	56	57	58	59	60	61	62	63	64	65	66	67	68	69	70	71	72	73	74	75	76	77	78	79	80	81	82	83	84	85	86	87	88	89	90
52	53	54	55	56	57	58	59	60	61	61	61	62	62	63	63	64	64	64	65	66	67	68	69	70	71	71	72	74	76	78	79	79	80	80	81
DISCHARGE AIR DRY BULB TEMPERATURE																																			
INLET AIR DRY BULB TEMPERATURE MUST BE BETWEEN 75° AND 110°F																												NK1344A							

**Fig. 6—Performance Temperature Chart—Roof Unit of Dual System**



**Fig. 7—Roof Unit Performance Test**

stabilized condition on the gauges and thermometers has been established. One of the most important factors in making the over-all performance test is that the engine must be operated at 1300 rpm for a sufficient time to build up to operating temperatures and allow all the under-hood components of the system to be subjected to the under-hood operating

temperatures for a period of time.

(5) Partially close the needle valve, located below the discharge pressure gauge, to minimize oscillation of the discharge gauge pointer. Do not close the needle valve completely since this would prevent discharge pressure gauge from registering discharge pressure.

(6) Read the discharge pressure on the gauge. This test should be performed with the discharge pressure from 190 to 210 psi. The 190 to 210 pound-pressure is for test purposes only. These pressures change according to the ambient temperature, humidity and the efficiency of the entire system.

(7) Take the necessary steps to bring and maintain the discharge pressure within these limits.

To increase the discharge pressure, restrict the air flow across the condenser using cardboard, or paper. In high ambient temperatures and high humidity areas, it may be necessary to put an electric fan in front of the condenser to keep the pressure down to these limits.

(8) Observe and record the "Inlet Dry Bulb Tem-

FRONT UNIT ONLY																																			
INLET WET BULB TEMPERATURE VERSUS DISCHARGE DRY BULB TEMPERATURE																																			
INLET AIR WET BULB TEMPERATURE																																			
55	56	57	58	59	60	61	62	63	64	65	66	67	68	69	70	71	72	73	74	75	76	77	78	79	80	81	82	83	84	85	86	87	88	89	90
41	42	43	44	45	46	48	49	50	51	51	51	52	52	54	54	55	55	55	56	56	58	59	60	61	62	62	64	66	68	70	71	72	73	74	75
DISCHARGE AIR DRY BULB TEMPERATURE																																			
INLET AIR DRY BULB TEMPERATURE MUST BE BETWEEN 75° AND 110°F																													NP655						

**Fig. 8—Performance Temperature Chart—Front Unit Only—Imperial**

FRONT UNIT OF DUAL																																			
INLET WET BULB TEMPERATURE VERSUS DISCHARGE DRY BULB TEMPERATURE																																			
INLET AIR WET BULB TEMPERATURE																																			
55	56	57	58	59	60	61	62	63	64	65	66	67	68	69	70	71	72	73	74	75	76	77	78	79	80	81	82	83	84	85	86	87	88	89	90
43	44	45	46	47	48	50	51	52	53	53	53	54	54	56	56	57	57	57	58	58	60	61	62	63	64	64	66	68	70	72	73	74	75	76	77
DISCHARGE AIR DRY BULB TEMPERATURE																																			
INLET AIR DRY BULB TEMPERATURE MUST BE BETWEEN 75° AND 110°F																													NP653						

**Fig. 9—Performance Temperature Chart—Front Unit of Dual—Imperial**



TRUNK UNIT OF DUAL																																			
INLET WET BULB TEMPERATURE VERSUS DISCHARGE DRY BULB TEMPERATURE																																			
INLET AIR WET BULB TEMPERATURE																																			
55	56	57	58	59	60	61	62	63	64	65	66	67	68	69	70	71	72	73	74	75	76	77	78	79	80	81	82	83	84	85	86	87	88	89	90
42	43	44	45	46	47	49	50	51	52	52	52	53	53	55	55	56	56	56	57	57	59	60	61	62	63	63	65	67	69	71	72	73	74	75	76
DISCHARGE AIR DRY BULB TEMPERATURE																																			
INLET AIR DRY BULB TEMPERATURE MUST BE BETWEEN 75° AND 110°F																											NP654								

**Fig. 10—Performance Temperature Chart—Trunk Unit of Dual—Imperial**

perature” and “Inlet Wet Bulb Temperature” as registered on the psychrometer.

(9) Observe and record “Discharge Air Temperature” registered by the thermometer at right-hand grille outlet.

(10) From the approximate Roof Unit Performance Temperature Chart for vehicle and type installation being tested (Fig. 6), determine the maximum allowable discharge air temperature for the prevailing “Dry” and “Wet” bulb temperatures. If the discharge air temperature is at or below the temperature given on the Performance Chart, the roof unit is delivering its rated cooling capacity.

If the discharge air temperature at the outlet grilles is above the maximum allowance on the “Performance Chart,” perform the “Expansion Valve and Evaporator Pressure Regulator Valve Test.”

**Pilot Operated Evaporator Pressure Regulator (EPR) (Fig. 11)**

An improved version of the Evaporator Pressure Regulator (EPR) Valve, has been introduced this year.

Like the EPR valve, it is entirely self contained, requires no external motivation and is located in the suction cavity of the compressor.

Its purpose is to restrict the flow of refrigerant under light air conditioning loads. This is done in order to keep the evaporator pressure high enough to prevent freeze-up of the condensate on the external surfaces of the evaporator. Such a condition would restrict air flow, and under extreme circumstances, result in complete loss of capacity.

The **Pilot Operated EPR** differs from the EPR (internally), in that it contains a built-in pilot valve, which “triggers” the main throttling portion of the valve. The valve offers more precise control, and permits system operation at lower ambient temperatures, before evaporator “freeze-up” occurs.

**NOTE:** If the EPR valve must be removed or replaced,

it is to be replaced by the pilot operated EPR valve identified by Part Number 3406143. No attempt shall be made to adjust the valve. All further reference to the EPR Valve in this Manual will apply to the Pilot Operated EPR Valve only.

**TEST 6**

**EXPANSION VALVE AND EPR VALVE TEST (In Car) SINGLE UNIT OR FRONT UNIT OF DUAL**

This test is to be performed after performing Test 1 through 5. The gauge set manifold will be connected as illustrated. (Fig. 12).

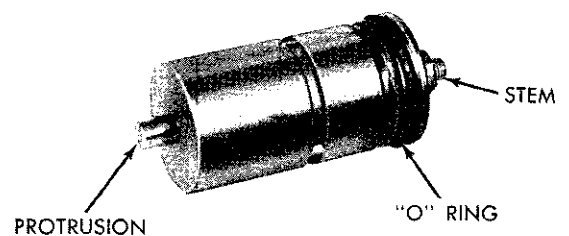
**(1) Preliminary Checks**

Before performing any of the tests listed in Section 3, the following conditions shall be established.

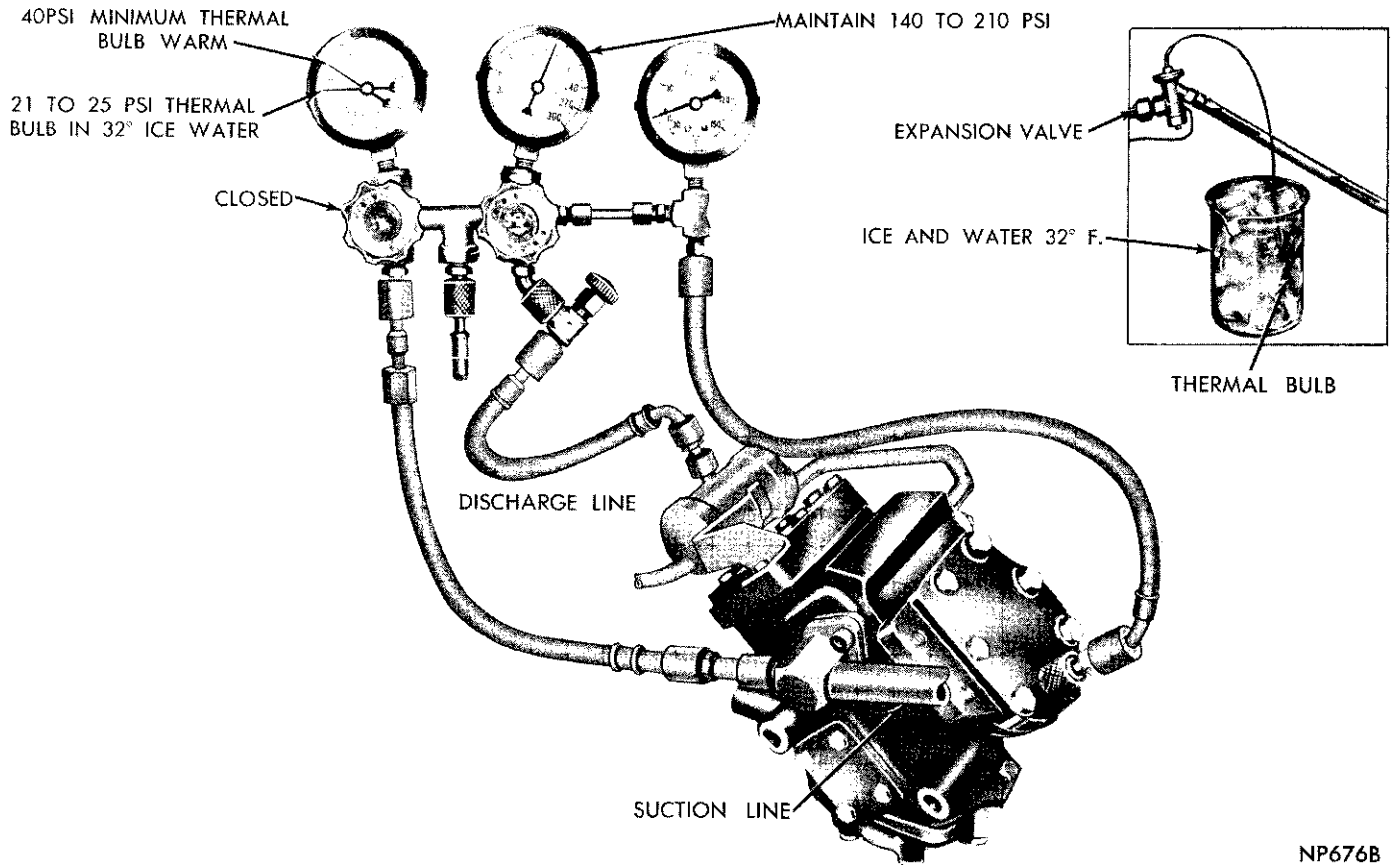
- (a) System must be adequately charged in accordance with Test 2.
- (b) Make sure sensing tubes of the expansion valve are not damaged. Replace any expansion valve that has broken or damaged tube. Be sure sensing tube is properly inserted in its well in the suction line. (Fig. 13).

**(2) Test Conditions for all Requirements Except 3(d)**

- (a) Test must be made at room temperature of 75 degrees F. minimum, under hood temperature 86 degrees F. minimum.



**Fig. 11—Pilot Operated EPR Valve**



NP676B

**Fig. 12—Expansion Valve and EPR Valve Test**

- (b) Close the doors and windows, set the air conditioning controls for Max. A/C, high blower and temperature lever to maximum temperature position. NOTE: An external vacuum source must be used to open the water valve.
- (c) Set the engine speed at 900 rpm unless otherwise specified.
- (d) Operate the system for at least ten minutes to obtain partial stabilization and sufficient re-heat to load the evaporator.

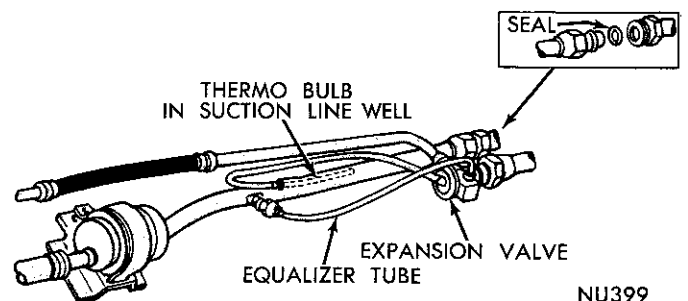
**(3) Requirements**

Check the system as follows and refer to Diagnosis Chart if findings are different from these specified.

- (a) Under conditions in paragraph 2, pressure shall be as follows when the sensing tube of the expansion valve is in its well.
  - Head Pressure 140 to 210 psi**
- (b) Under conditions in paragraph 2. Remove the expansion valve sensing tube from its internal well and hold it in your hand for several minutes until suction pressure stabilizes. The pressure should read:
  - Evaporator suction pressure 40 psi or more.**
  - Compressor Inlet pressure no more than 4 psi below evaporator suction pressure.**
- (c) Under conditions in paragraph 2, immerse 5 inches of the sensing tube in a container of ice

- water at 32 degrees F. The pressure should read:
  - Evaporator Suction Pressure Not More Than 27 psi**
  - Compressor Inlet Pressure 17 psi or Less**
- (d) This check must be performed under the following conditions:
  - Engine Speed 1500 rpm**
  - Blower on Low Speed**
  - Max. A/C Button Depressed**
  - Temperature Control Lever in Minimum Temperature Position. Disconnect External Vacuum.**
 The sensing tube of the expansion valve must be in its well in the suction line. The pressures should read:

**Evaporator Suction Pressure 23-27 psi**  
**Compressor Inlet Pressure 17 psi or Less**



NU399

**Fig. 13—Expansion Valve Details**

## EXPANSION VALVE AND EPR VALVE DIAGNOSIS CHART

Condition	Possible Cause	Correction
Head Pressure Below 140 psi (Ref. 3 a)	Expansion Valve Closed EPR Valve Closed Compressor not Properly Working	See 4(a) See 4(b) Replace valve plates & gaskets of compressor
Low Evaporator Suction Pressure Below 23 psi (Ref. 3 b)	Expansion Valve Closed EPR Valve not Controlling (open)	See 4(a) See 4(d)
High Pressure Differential (Ref. 3 b)	EPR Valve (closed)	See 4(b)
Evaporator Suction Pressure Between 27 and 40 psi (Ref. 3 b)	Expansion Valve Defective Lack of Capacity	See 4(a)
Compressor Inlet Pressure Higher than 17 psi (Ref. 3 c) Expansion Valve Known to be Good	EPR Valve Defective Compressor Defective	See 4(d) Replace valve plates & gasket of compressor
Evaporator Suction Pressure Does not Drop (Ref. 3 c)	EPR Valve Not properly set (high control point) Expansion Valve—Not working properly (sticking open) Compressor Defective	See 4(c) See 4(c)
Evaporator Suction Pressure Not Between 23 and 27 psi (Ref. 3 d)	EPR not Set Properly	Replace EPR Valve
Compressor Inlet Pressure Higher than 17 psi (Ref. 3 d) Expansion Valve Known to be Good	EPR Valve Defective Compressor Defective	See 4(d) Replace valve plates & gasket of compressor

**(4) Tests**

Refer to the Diagnosis Chart.

- (a) Remove the sensing tube of the expansion valve from its well and hold it in your hand. Read the evaporator suction pressure. It should read 40 psi or more. If the evaporator suction reads less than 40 psi, replace the expansion valve. If the evaporator suction pressure reads more than 40 psi, proceed with Test (b).
- (b) Remove the sensing tube of the expansion valve from its well. Hold it in your hand, allow time for equalization. Observe the differential pressure. If the evaporator suction pressure is more than 40 psi and the differential pressure between the evaporator suction pressure and compressor inlet pressure is more than 4 psi, the EPR valve is defective and should be replaced.
- (c) Perform the test as in (b). If the EPR valve is satisfactory, immerse the expansion valve sensing tube in ice water at 32 degrees F. The evaporator suction pressure should drop below 27 psi. If it does not drop to this value raise

the engine speed to 1750 rpm and check the evaporator suction pressure again. If it remains above 27 psi and the compressor inlet pressure is more than 4 psi, the EPR valve has too high control point and should be replaced. If the pressure drop is less than 4 psi and the evaporator suction pressure is above 27 psi, the expansion valve is defective and should be replaced.

If after raising the engine rpm to 1750, the evaporator suction pressure drops below 27 psi, both EPR and expansion valve are working properly, but the compressor capacity is low.

The compressor valve plates and the gaskets should be inspected and replaced if necessary.

- (d) Remove the sensing tube from its well and hold it in your hand. Read the evaporator suction pressure then immerse the sensing tube in ice water at 32 degrees F. and read the evaporator suction pressure which should be below 27 psi. If the pressure does not drop to this value, read the compressor inlet pressure. It should be 17 psi or less. If it is more than 17

psi, the EPR valve is faulty and must be replaced.

If the compressor inlet pressure is still above 17 psi, inspect the valve plates and gaskets and replace them if necessary.

**EXPANSION VALVE TEST DUAL UNIT (Roof Unit)**

The expansion valves for the front and rear units of a dual unit installation will have to be tested separately as follows:

(a) Close car doors and windows and operate the engine at 800 rpm. Set air conditioning controls at "Max. A/C" high blower and temperature control lever to full reheat position.

(b) Operate the system for a few minutes to obtain partial stabilization and sufficient reheat to load the evaporator. The pressure at the discharge service port should read between 140 and 210 psi. before starting the test (expansion valve thermo bulb in well).

(c) Place the sensing element thermo bulb of the rear unit expansion valve in a salt and ice water brine which is at a temperature of 18°F., or lower and place the expansion valve thermo bulb of the front unit in a container of 32°F., ice water. The evaporator suction pressure should read between 21 to 28 psi. The compressor inlet pressure should be 22 psi. or less. If the compressor inlet pressure is higher than 22 psi., the EPR valve should be replaced. If the evaporator suction pressure is greater than 28 psi., the EPR valve cannot be checked until after the expansion valve passes the test; read step (g) and continue with the test, step (d).

(d) Remove the front unit thermo bulb from the ice water and hold the bulb in your hand for several minutes until the suction pressure stabilizes. The evaporator suction pressure should read a minimum

of 40 psi. Any expansion valve which does not produce this reading is defective and should be replaced.

With the evaporator suction pressure reading a minimum of 40 psi. under the conditions in step (d) above, the compressor inlet pressure should read 1 to 4 psi. less. If the compressor inlet pressure is more than 4 psi less than the evaporator suction pressure, the EPR valve is defective and should be replaced.

(e) Then, place the front unit expansion valve thermo bulb in the 18°F., ice water and brine solution and place the rear unit thermo bulb in the 32°F., ice water solution. The evaporator suction pressure should read 17 to 25 psi.

(f) Remove the rear unit expansion valve thermo bulb from the ice water solution and hold the bulb in your hand for several minutes until the suction pressure stabilizes. The evaporator suction pressure should read a minimum of 35 psi. Any expansion valve which does not produce this reading is defective and should be replaced.

(g) If the evaporator suction pressure was greater than 28 psi. (step c) and 25 psi. (step e), one or possibly both of the expansion valves are stuck open. The expansion valve that produced the least evaporator suction pressure change when its thermo bulb was moved from in the 32°F., ice water to in the hand location, is stuck open and should be replaced. After replacing the defective expansion valve, charge the system and repeat the testing of the other expansion valve.

If the expansion valve passes Test (a) through (g), then the compressor valve plate should be removed and the gaskets and valves inspected. Replace gaskets and any damaged valve plate assemblies. **Make sure that all of the old gasket material is removed from the valve plates, cylinder head and crankcase before rebuilding the compressor.**

**COMPLETE SYSTEM DISCHARGE AND RECHARGE**

**INDEX**

	Page		Page
Charging the System .....	23	Replace Receiver Drier-Strainer .....	22
Discharge the System .....	21	Removing Sweep-Test Charge .....	22
Evacuate the System .....	22	Sweep-Test Charge .....	21
Refrigerant Service .....	20	Testing the System for Leaks .....	21

**REFRIGERANT SERVICE**

Use only Refrigerant 12 in the air-conditioning system. Refrigerant 12 is available in bulk tanks or in sealed 15 ounce cans. The use of canned refrigerant is preferred by most technicians because it provides a very quick and simple means of adding re-

frigerant or charging the system completely. Refer to the Refrigerant Charge Chart.

**An accurate scale must be used to insure charging with the proper amount of refrigerant.**

Since the use of canned refrigerant is preferred universally, only that method is described.

Before the system can be opened for replacement

## REFRIGERANT CHARGE

Single	Dual
3 lbs. 2 oz. to 3 lbs. 6 oz.	4 lbs. 2 oz. to 4 lbs 6 oz.

of lines or components, the system must be completely discharged. Whenever the system has been opened, it must be swept with a partial charge, and the entire system tested for leaks. Compressor oil level should be checked and adjusted, if necessary. See "Oil Level". The drier should be replaced and the system evacuated using a vacuum pump to remove all air and moisture. The system should be charged with the proper amount of refrigerant. Detailed instruction for performing these operations follow.

### DISCHARGE THE SYSTEM

(1) Be sure the valves of the gauge manifold set are closed before attaching the gauge set manifold (suction test hose to the suction service port and discharge test hose to the discharge service port). Attach the long test hose to the center connection of the gauge set manifold. Lead the other end of this hose into an exhaust ventilation system outlet or to the outside of the building.

(2) Open the gauge set manifold needle valve and close both of the gauge set manifold gauge valves.

(3) With the vehicle windows open and hood up, operate the engine at 1300 rpm.

(4) Push in "A/C" button, fan switch on high. On dual installation both blowers must be on high speed during the charging operation.

(5) Allow the system to operate at full capacity for at least 15 minutes at the rpm shown in step (3). This will cause most of the compressor oil in the system to return to the compressor crankcase.

(6) Open the discharge right-hand gauge valve a small amount. This will allow the refrigerant vapor to discharge slowly.

**CAUTION: Do not allow the system to discharge rapidly since this would sweep some of the refrigerant oil out of the compressor.**

(7) Allow the system to discharge until the discharge pressure gauge registers zero. Open the left-hand valve to release any vapor trapped at the suction side of the system.

### SWEEP-TEST CHARGE

The purpose of the sweep-test charge is to pressurize the system so that a leak test can be made. The sweep-test charge also serves the purpose of drying the system or sweeping out trapped moisture. Repairs

and component replacement must be completed before charging with the sweep-test charge.

(1) Close both gauge set manifold valves and open the gauge set manifold needle valve.

(2) Attach the free end of the long hose used for discharging to the refrigerant dispensing manifold.

(3) Attach a single can of Refrigerant 12 to the dispensing manifold. Place the refrigerant in 125 degree water. For detailed instructions on attaching refrigerant can for charging, see "Charging the System" in this section.

(4) With vehicle windows open and hood up, operate engine at 1300 rpm.

(5) Push in "A/C" button, fan switch on high. On dual installation both blowers must be on high speed during the charging operation.

(6) Slowly open the left-hand gauge set manifold valve to meter the refrigerant into the system. When the full can of refrigerant has been metered into the system, close the gauge set manifold valves and the refrigerant manifold valve.

If the system has been opened for repair or replacement, a complete leak test must be made to make sure the system is sealed. Also, if the system has accidentally lost its charge it will be necessary to perform a leak test while the sweep-test charge is in the system. Stop the engine and disconnect the test hoses and adapters from the compressor service ports.

### TESTING THE SYSTEM FOR LEAKS

The leak detector torch Tool C-3569 is a propane gas-burning torch used to locate a leak in any part of the refrigeration system. Refrigerant gas drawn into the sampling or "snifter" tube will cause the flame to change color in proportion to the size of the leak. A very small leak will produce a flame color varying from yellowish-green to bright green. A large leak will produce a brilliant blue flame.

**CAUTION: Do not use the lighted detector in any place where explosive gases, dust, or vapor are present. Do not breathe the fumes that are produced by the burning of refrigerant gas. Large concentrations of refrigerant in the presence of a live flame become dangerously toxic. Observe the flame through the window of the burner shield, not through the top of the shield.**

(1) Open the torch valve until you hear a faint hiss of escaping gas. Light the test torch and adjust the valve until the flame is very small. A small flame will detect large as well as small leaks, whereas, a large flame will detect only large leaks. As soon as the reaction plate seen through the window in the burner shield becomes red hot, the tester is ready for use.

(2) Examine all the tube connectors and other possible leak points by moving the end of the sampling

hose from point to point. Since Refrigerant 12 is heavier than air, it is good practice to place the open end of the sampling hose directly below the point being tested. Be careful not to pinch the sampling tube since this will shut off the air supply to the flame and cause a color change.

(3) Watch for a change in the color of the flame. Small leaks will produce a green color and large leaks a bright blue color. If leaks are observed at the tube fittings, tighten the connection, using the proper flare wrenches, and retest.

If the flame remains bright yellow when the tester is removed from a possible leak point, insufficient air is being drawn in through the sampling tube, or the reaction plate is dirty.

### REMOVE SWEEP-TEST CHARGE

If the system is free of leaks, or after correcting a leak, if no air-conditioning components have been removed, add the necessary refrigerant as described under "Correcting the Low Refrigerant Level." If any parts of the refrigerant system were disconnected remove the sweep-test charge. Close the refrigerant manifold valve so that any refrigerant remaining in the container is sealed. Remove the long test hose from the refrigerant manifold. Insert the free end of this test hose into an exhaust system outlet. Open the

right-hand gauge set manifold valve a fraction of a turn to let the sweep-test charge escape slowly. Allow the system to discharge until the discharge pressure gauge registers zero. Open the left-hand gauge valve to allow any refrigerant trapped in the suction side of the system to escape.

### REPLACE THE RECEIVER-DRIER

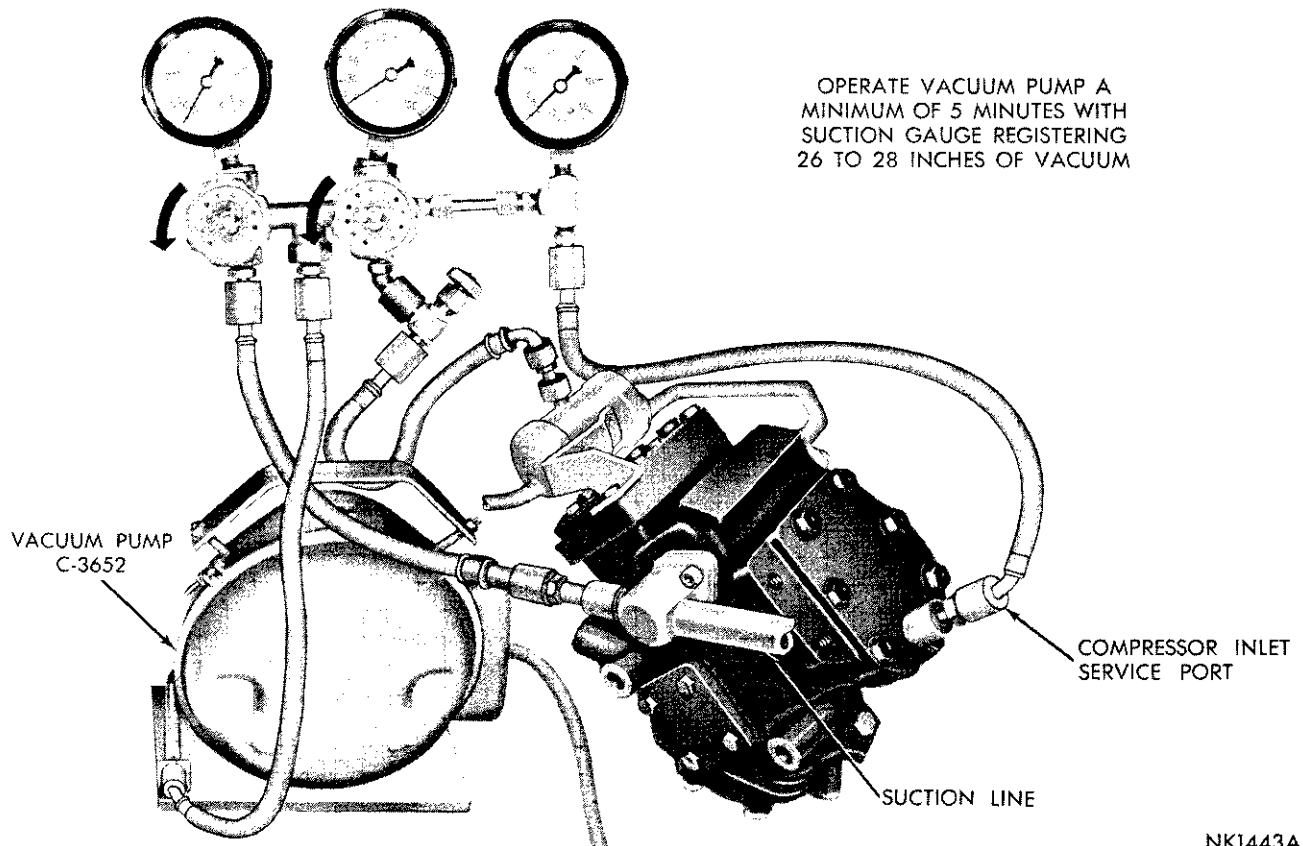
The system must be discharged and swept with a test charge before replacing the receiver-drier.

To remove the receiver-drier, simply unscrew it at the fittings and disconnect Low Pressure Cut-out wires. When installing a new receiver-drier, use new "O" rings. Tighten the new unit to 40 foot-pounds. **Do Not** overtighten as this might damage the "O" rings. Connect Low Pressure Cut-out wire.

**CAUTION:** Replacement receiver-drier-strainer units must be sealed while in storage. The drier used in these units is so hungry for moisture that it can saturate quickly upon exposure to the atmosphere. When installing a drier, have all tools and supplies ready for quick reassembly to avoid keeping the system open any longer than necessary.

### EVACUATE THE SYSTEM

Whenever the system has been opened to atmosphere, it is absolutely essential that the system be



OPERATE VACUUM PUMP A MINIMUM OF 5 MINUTES WITH SUCTION GAUGE REGISTERING 26 TO 28 INCHES OF VACUUM

Fig. 1—Evacuating the System

swept with refrigerant and evacuated or "vacuumed" to remove all the air and the moisture. If any appreciable amount of air remains in the system when it is charged, the trapped air will concentrate near the top of the condenser and cause abnormally high discharge pressure. Air in the system will reduce the condenser's ability to condense the refrigerant gas and supply adequate liquid refrigerant to the evaporator. To evacuate the system, proceed as follows:

- (1) Connect gauge set manifold to compressor and long test hose from gauge set manifold center connection to vacuum pump, Tool C-3652. (Fig. 1).
- (2) Open both gauge set manifold valves, and the needle valve.
- (3) Start the vacuum pump and operate until the evaporator suction gauge registers at least 26 inches of vacuum. If system is tight and pump in good condition, vacuum will go as low as 28 inches.
- (4) Allow vacuum pump to operate with the suction gauge registering 26 to 28 inches of vacuum for a minimum of five minutes.
- (5) Close both gauge set manifold valves, turn off vacuum pump and remove test hose from vacuum pump. Leave gauge set manifold connected to compressor. Charge system with proper amount of Refrigerant 12. **Failure to pull at least 26 inches of**

vacuum indicates a leak in the refrigeration system or a defective vacuum pump. Locate and correct the trouble before recharging the system.

### CHARGING THE SYSTEM (Fig. 2)

An accurate scale must be used to insure charging with the proper amount of refrigerant.

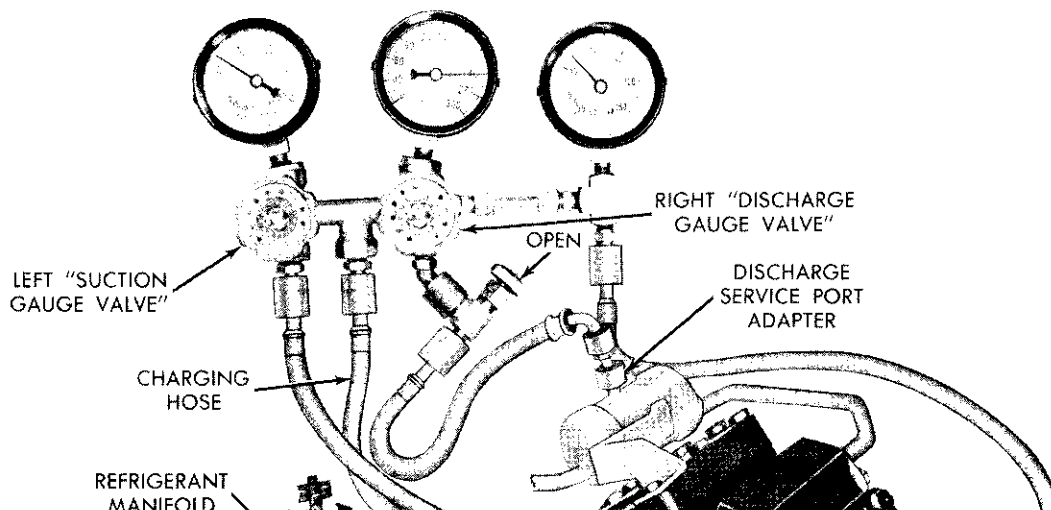
#### REFRIGERANT CHARGE

Single	Dual
3 lbs. 2 oz. to 3 lbs. 6 oz.	4 lbs. 2 oz. to 4 lbs. 6 oz.

The special refrigerant dispensing manifold permits charging three full cans of refrigerant at one time.

Keep the refrigerant manifold valves capped when not in use. Keep a supply of extra refrigerant-can-to-refrigerant-manifold gaskets on hand so that gaskets can be replaced periodically. This will insure a good seal without excessive tightening of the can or the manifold nuts.

- (1) Attach center hose from gauge set manifold to refrigerant dispensing manifold. Turn refrigerant manifold valves completely counterclockwise so they



are fully open. Remove protective caps from refrigerant manifold.

(2) Screw refrigerant cans into manifold. Be sure manifold-to-can gasket is in place and in good condition. Tighten can and manifold nuts to 6 to 8 foot-pounds.

(3) Turn three refrigerant manifold valves completely clockwise to puncture the cans and close the manifold valves.

(4) Turn refrigerant manifold valves counterclockwise to open them.

(5) Momentarily loosen the charging hose at the gauge set manifold to allow the refrigerant gas to purge air out of the charging hose.

(6) Place the three cans of refrigerant into a pan

containing hot water at a temperature of 125 degrees F.

(7) Start engine and adjust speed to 1300 rpm.

(a) Charge the system through the suction side of the system by slowly opening the left-hand gauge set manifold valve. Adjust valve as necessary so charging pressure does not exceed 50 psi. Maintain the temperature of the water in the pan by adding warm water as necessary.

(b) When all three cans of refrigerant are completely empty, close gauge set manifold valves and refrigerant manifold valves.

(c) If more than three cans of refrigerant are necessary to complete charge repeat steps two through six.

### SERVICE PROCEDURES

#### INDEX

	Page
Anti-Freeze Recommendations .....	25
Compressor Drive Belt Adjustment .....	25
Handling Tubing and Fittings .....	24

	Page
Radiator Pressure Cap .....	25
Vacuum Control System Adjustments and Tests ..	25

### HANDLING TUBING AND FITTINGS

Kinks in the refrigerant tubing or sharp bends in the refrigerant hose lines will greatly reduce the capacity of the entire system. High pressures are produced in the system when it is operating. Extreme care must be exercised to make sure that all connections are pressure tight. Dirt and moisture can enter the system when it is opened for repair or replacement of lines or components. The following precautions must be observed.

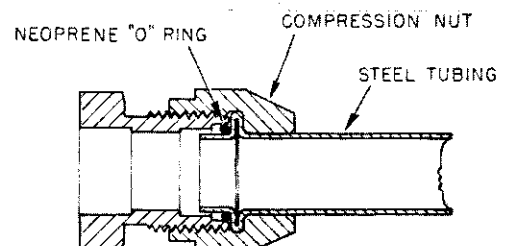
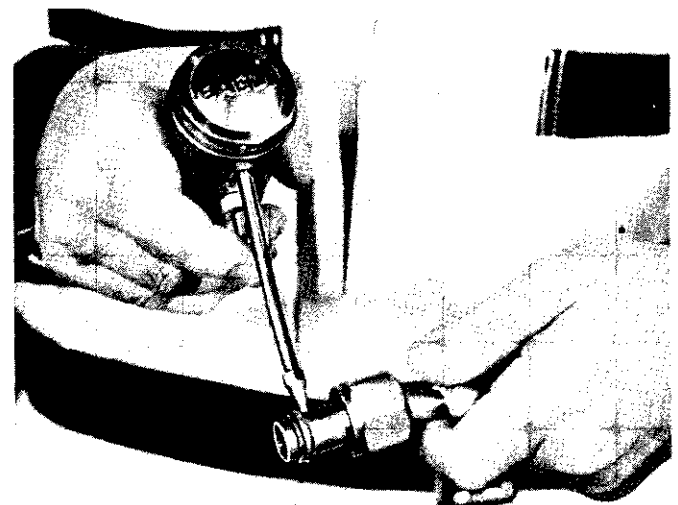
The system must be completely discharged before opening any fitting or connection in the refrigeration system. Open fittings with caution even after the system has been discharged. If any pressure is noticed as a fitting is loosened, allow trapped pressure to bleed off very slowly. Use a suitable tube bender when bending the refrigerant lines to avoid kinking. **Never attempt to rebend formed lines to fit. Use the correct line for the installation you are servicing.**

A good rule for the flexible hose lines is keep the radius of all bends at least 10 times the diameter of the hose. Sharper bends will reduce the flow of refrigerant. The flexible hose lines should be routed so that they are at least 3 inches from the exhaust manifold. It is good practice to inspect all flexible hose lines at least once a year to make sure they are in good condition and properly routed.

"O" rings and fittings must be in good condition. The slightest burr or foreign material may cause a leak. "O" rings and fittings must be coated with refrigerant oil to allow the connections to seat squarely

and to be tightened evenly to the proper torque. Fittings which are not oiled with refrigerant oil are almost sure to leak (Fig. 1).

The use of proper wrenches when making connections is very important. Improper wrenches or improper use of wrenches can damage the fittings. Al-



NY884B

Fig. 1—Lubricate with Refrigerant Oil (Typical)



ways use two wrenches when loosening or tightening tube fittings to prevent distorting of lines and components.

The internal parts of the refrigeration system will remain in a state of chemical stability as long as pure-moisture-free Refrigerant 12 and refrigerant oil is used. Abnormal amounts of dirt, moisture or air can upset the chemical stability and cause operational troubles or even serious damage if present in more than minute quantities.

When it is necessary to open the refrigeration system, have everything you will need to service the system ready so that the system will not be left open any longer than necessary. Cap or plug all lines and fittings as soon as they are opened to prevent the entrance of dirt and moisture. All lines and components in parts stock should be capped or sealed until they are ready to be used.

All tools, including the refrigerant dispensing manifold, the gauge set manifold and test hoses should be kept clean and dry.

The special refrigeration oil supplied for the system is as clean and dry as it is possible to make it. **Only refrigeration oil** should be used in the system or on the fittings and lines. The oil container should be kept tightly capped until it is ready for use, and then tightly capped after use to prevent entrance of dirt and moisture. Refrigerant oil will quickly absorb any moisture with which it comes in contact.

## COMPRESSOR DRIVE BELT ADJUSTMENT

If the proper tensions are not maintained, belt slippage will greatly reduce air-conditioning performance and drive belt life.

(1) Adjust air-conditioning drive belts at the time of new-car preparation. See Chart, "Accessory Belt Drives." Group 7—Cooling.

(2) Measure drive belt tension at regular service intervals using torque method, and adjust as needed.

(3) Always replace belts in pairs if so equipped, otherwise the old belt will have insufficient tension and the load will be primarily on the new belt.

## ANTIFREEZE RECOMMENDATIONS

The Air-Conditioning System requires the engine's cooling system to be protected to  $+15^{\circ}\text{F}$ . with a permanent type antifreeze for summer operation. This is to prevent freezing of the coolant in the heater core.

However, this protection does not provide sufficient corrosion inhibitors for the engine cooling system. Summer protection to  $-15^{\circ}\text{F}$ . will provide adequate inhibitors for protection of engine cooling system against corrosion.

In the springtime, after the winter's operation with

the cooling system protected with permanent-type antifreeze for the temperatures of the area, it is suggested the system be drained and flushed out with water. When draining, flushing and refilling, have the temperature control lever in the extreme hot position so the heater core is drained, flushed and refilled. Install a gallon of permanent type antifreeze in the system, and add enough water to fill the system.

**Do not re-use the old antifreeze.** The permanent type antifreeze does not lose its antifreeze qualities during the winter season operation, but the chemical inhibitors for rust and corrosion prevention are weakened and finally exhausted by extended use. Do not add new inhibitor to used antifreeze in hope of revitalizing the used antifreeze.

The chemical inhibitors come in various chemical compositions, some are compatible, some neutralize each other, and some form violent reactions to each other causing foaming and other undesirable reactions. Play it safe and use new permanent-type antifreeze.

## RADIATOR PRESSURE CAP

Air conditioned vehicles must be equipped with a 15 to 16 psi radiator cap.

A radiator pressure cap testing below these specifications will permit loss of coolant during a hard pull on a hot day, or in slow moving traffic, or when the engine is stopped on a hot day.

Test the radiator pressure cap, using Tool C-4080 (Fig. 2). Before assembling adapter and radiator pressure cap to the pump, dip radiator cap and both ends of adapter into clean water to assure a tight seal.

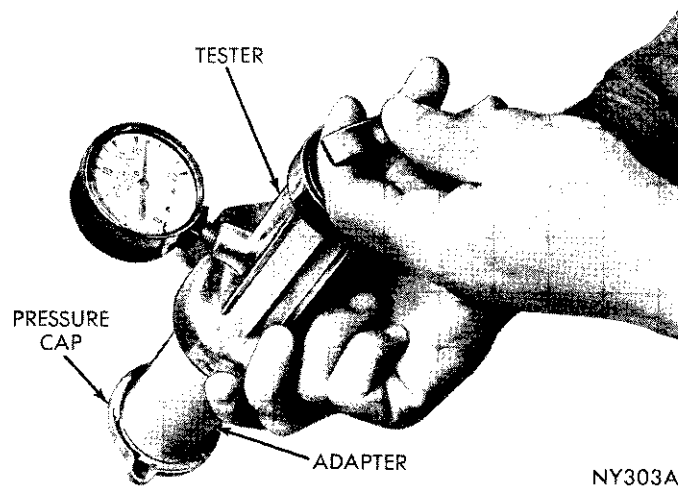
Hold the assembled tester in a vertical position with the radiator cap downward. (Fig. 2). Stroke the tester pump plunger until the gauge indicates the pressure cap is relieving pressure. It must relieve at a pressure between 14 to 17 psi. If within these specifications, re-install on the radiator.

**These test specification are for caps tested at average altitudes. In high altitudes, the test specifications are lowered about one (1) psi for each 2,000 feet above sea level.**

**If the radiator cap does not test within these specifications, replace it with a cap that does.**

## VACUUM CONTROL SYSTEM ADJUSTMENTS AND TESTS

The test of the push-button operation determines whether or not the vacuum and electrical circuits are properly connected and the controls are functioning properly. However, it is possible that a vacuum control system that operates perfectly at the high vacuum provided at engine idle speed may not function



**Fig. 2—Radiator Cap Tester**

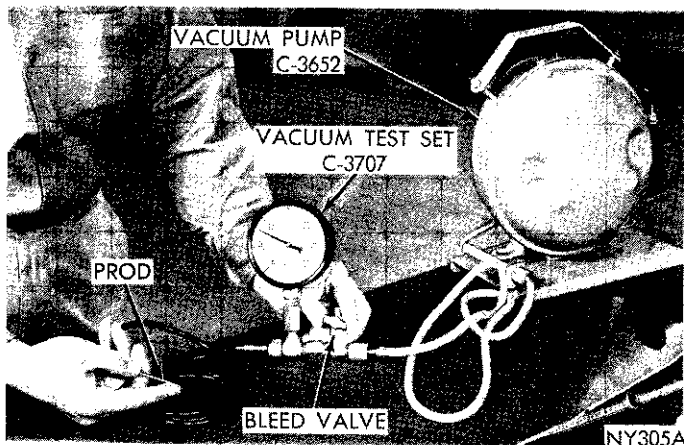
properly at high engine speeds. Before starting this test, stop engine and make certain the vacuum source hose at engine intake manifold is tight on its connector.

Start vacuum pump (Tool C-3652) and connect to the vacuum test set (Tool C-3707). Adjust bleed valve on test set to obtain exactly 8 inches of vacuum with a finger blocking the prod on end of test hose (Fig. 3).

It is absolutely essential that the bleed valve be adjusted so the vacuum gauge pointer will return to exactly 8 inches when the prod is covered by a finger. Otherwise a false reading will be obtained when the control circuit is tested.

**CAUTION:** Alternately release and reblock the hose prod several times. Make sure the bleed valve is adjusted so the vacuum gauge pointer returns to exactly 8 inches of vacuum when the prod is covered with a finger.

Disconnect engine vacuum source hose at engine intake manifold and insert vacuum tester hose prod into source hose leading to control switch. Place vacuum gauge on the cowl so it can be observed from the driver's position as push buttons are operated.



**Fig. 3—Adjusting Vacuum Test Bleed Valve**

Start the test by pushing the "Heat" button. Vacuum tester gauge needle will drop until the actuator has operated, and then will return to 8 inches. Note how much the vacuum drops below 8 inches. Continue to push buttons; "Off," "Max A/C" "A/C" "Defrost" and "Heat" allowing time for actuators to operate after each button is pushed, and note the vacuum drop below 8 inches after each operation. The maximum allowable vacuum drop below 8 inches after each operation is 3/4 inch.

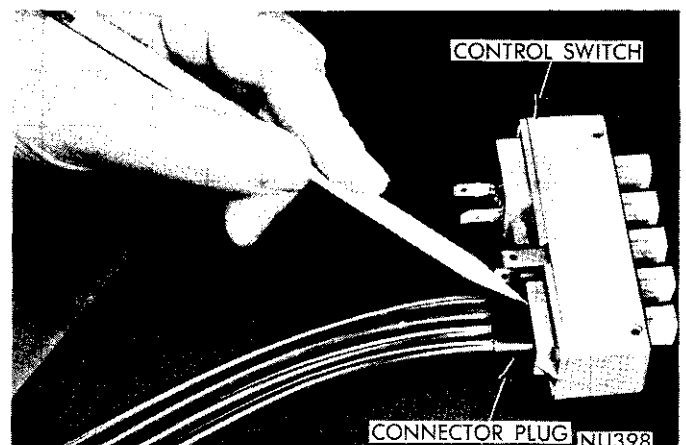
If the vacuum drop is more than 3/4 inch, first recheck the tester for reading exactly 8 inches. If correct, inspect the fit of the 7-hole hose connector plug on the control switch (Fig. 4). This plug must be positioned all the way on the 7 prods on the control switch.

**CAUTION:** Do not use lubricant on the switch prods or in the holes in the plug, as lubricant will ruin the vacuum valve in the switch. If it is impossible to properly position the connector plug all the way on the switch prods, put a drop or two of clean water in the holes of the connector plug. This will allow the plug to slide completely on the switch prods.

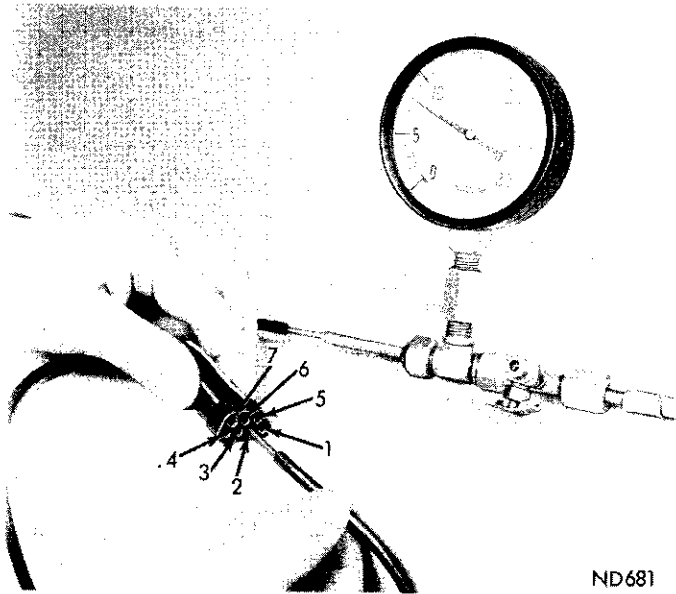
If vacuum drop is now within limits, proceed with the over-all performance test. If vacuum drop is still in excess of 3/4 inch, remove connector plug from the switch. Insert the vacuum test prod alternately in each of the connector holes except the source hose connector hole (Fig. 5). Note amount of vacuum drop below 8 inches after each actuator has operated. If vacuum test gauge comes back to 8 inches at each of the 6 holes, the hoses and actuators are not leaking. The control switch is faulty and must be replaced. If excessive vacuum drop shows up at one or more holes in connector block, isolate faulty hose or actuator.

Inspect hose connections to the actuator involved. Then test whether actuator or hose is at fault; use the test hose on the actuator involved (Fig. 6).

A leak in a hose may be detected with leak tester by running the fingers along the hose and watching vacuum gauge reading. A faulty spot may be cut out

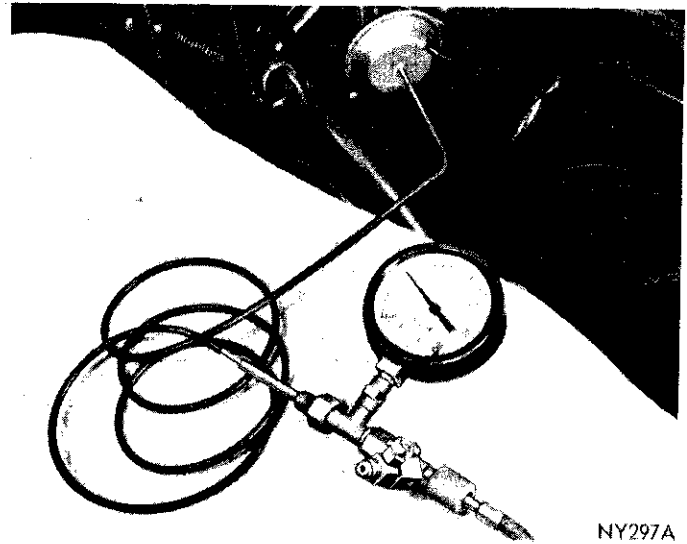


**Fig. 4—Push Button Vacuum Test**



**Fig. 5—Vacuum Tube Assembly Test**

and the hose spliced, using 1/8 inch 00 copper tubing. A vacuum drop in excess of 3/4 inch below the 8 inches needed in this test would not interfere with



**Fig. 6—Vacuum Actuator Test**

the engine operation, other than perhaps to cause a rough idle. It could, however, interfere with the proper operation of the air-conditioning and heating controls at high speeds and during acceleration.

## SERVICING THE COMPRESSOR

### INDEX

Compressor .....	Page 28
------------------	---------

Magnetic Clutch .....	Page 27
-----------------------	---------

### MAGNETIC CLUTCH

The compressor is equipped with an electro-magnetic clutch that is built-in the drive pulley assembly. (Fig. 1). An electro-magnetic field coil is mounted on the compressor and electrical connections are made directly to the coil lead. The electro-magnet does not rotate with the drive pulley, therefore, collector rings and brushes are eliminated.

#### Testing Electromagnet Current Draw

To test the coil for a short or open circuit, connect an ammeter (0-10 ampere scale) in series with a fully charged 12 volt battery and the field coil lead. The current draw at 12 volts and 68° temperature should be as follows:

2.7 to 3.3 amperes for Warner (Copper Wire).

4.0 to 4.6 amperes for Warner (Aluminum Wire).

**Note:** Housings on Aluminum coils bear the letter "AL".

#### Removal (All)

(1) Loosen and remove the belts. Disconnect clutch field lead wire at the connector.

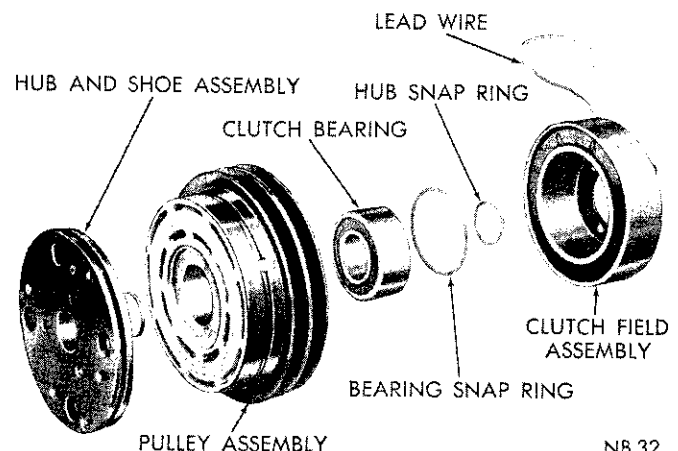
(2) Remove the special locking bolt and the washer from the compressor crankshaft at the front center of

the clutch.

(3) Insert a 5/8"-11 X 2-1/2" cap screw into the threaded portion of the hub assembly.

(4) Support clutch with one hand, then tighten cap screw until clutch is removed.

(5) Remove the three hexagon head screws attaching the clutch field assembly to the compressor and lift off the assembly.



**Fig. 1—Warner Clutch**

**Installation (All)**

(1) Install clutch field coil assembly on the base of compressor bearing housing. Make sure coil assembly is positioned so lead wire points to left of compressor as viewed from the front. Install the three mounting screws and tighten to 17 inch-pounds.

(2) Insert woodruff key in the crankshaft.

(3) Insert clutch assembly on crankshaft.

(4) Install washer and a new self-locking bolt. Hold clutch from turning with a spanner wrench inserted in the holes of front bumper plate. Tighten to 20 foot-pounds.

(5) Connect field lead wire.

(6) Install belts and tighten to specified tension.

**Disassembly**

(1) Remove the small snap ring from the drive hub.

(2) Install drive hub puller Tool C-3787 aligning the three pins of the Tool in the three holes in the hub and shoe assembly. Tighten the hex head bolt down until the drive hub is removed from the bearing (Fig. 2).

(3) Remove bearing snap ring from pulley.

(4) Place pulley assembly on an arbor press, with pulley side down, and bearing hub centered on Tool C-3825. Install Tool SP-3496 on inner race of bearing and press the bearing from pulley assembly (Fig. 3).

**A new bearing must be installed every time the magnetic clutch is disassembled.**

**Assembly**

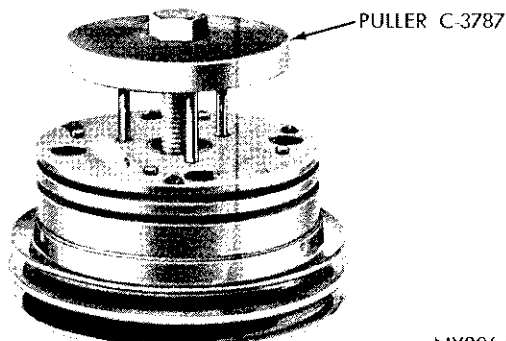
(1) Install pulley assembly with pulley side up on an arbor press and insert a **new** bearing into the bore. Install Tool C-3807 against the bearing and press into position (Fig. 4).

(2) Install pulley assembly with pulley side facing down on Tool C-3807.

(3) Start drive hub into the inner bearing race, and press hub into position with an arbor press.

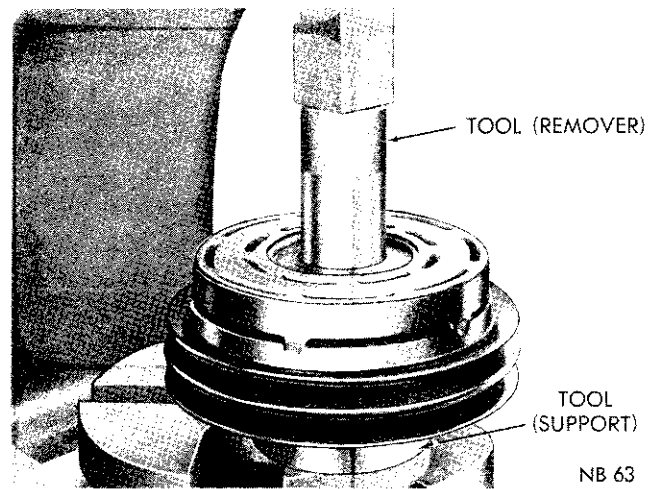
(4) Install bearing snap ring and hub snap ring.

**CAUTION: The pulley assembly and hub assembly are mated parts. They are burnished at the factory before shipment. No attempt should be made to replace either unit separately as this may reduce the initial torque of the clutch.**



**Fig. 2—Removing the Hub and Shoe Assembly**

NY896A

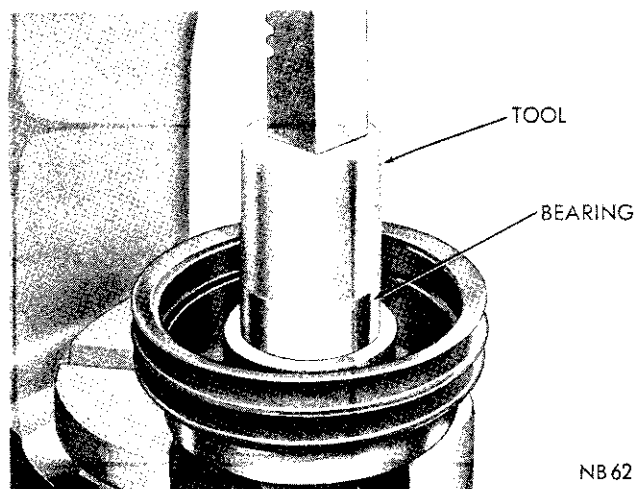


**Fig. 3—Removing the Bearing from Pulley Assembly**  
**COMPRESSOR**

The compressor is a two-cylinder, reciprocating-type designed specifically for the Chrysler Air-Conditioning System. Service parts are available so that the compressor can be repaired in the field.

Fig. 5 is a disassembled view of the compressor with the nomenclature of the parts. Some parts are serviced individually and some are serviced in packages which include two or more service parts. Refer to the parts book for this information.

**CAUTION: The refrigerant oil used in the compressor is carried through the entire system by the refrigerant. Some of this oil will be trapped and retained in the system when the refrigerant is discharged for testing or unit replacement. If the compressor is to be removed for repair or replacement, measure the refrigerant oil level in the compressor before the compressor is removed from the vehicle so that the same oil level can be established when the new or repaired compressor is installed on the vehicle.**



**Fig. 4—Installing a New Bearing in the Pulley Assembly (Typical)**



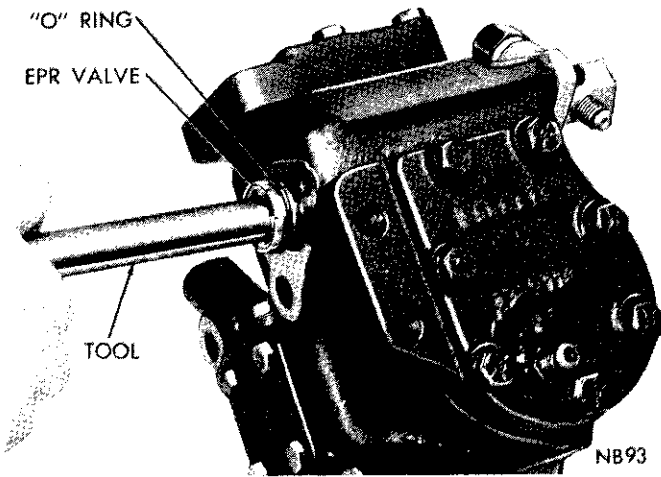


Fig. 6—Removing the EPR Valve

while rotating the valve counterclockwise.

(3) Install compressor suction screen in the "EPR" Valve suction line fitting.

(4) Install suction line fitting gasket, spring, fitting, and tighten the attaching bolts to 8 to 14 foot-pounds.

**COMPRESSOR**

**Removal**

(1) Discharge the system. (Refer to "Discharging the System.")

(2) Measure and record the refrigerant oil level so that the oil level of a replacement or repaired compressor can be adjusted to the exact level in the compressor removed from the vehicle. See "Oil Level."

(3) Disconnect suction line from suction muffler and the discharge line from the muffler fitting.

**CAUTION: Plug or cap all the lines as soon as they are disconnected to keep the moisture out of the system.**

(4) Disconnect the magnetic clutch-to-control-unit wire.

(5) Loosen and remove compressor pulley belts.

(6) Remove the compressor-to-bracket attaching bolts, and remove compressor.

**Installation**

(1) Install the compressor to the bracket, and tighten the attaching bolts.

(2) Install compressor pulley belts.

(3) Connect magnetic clutch-to-control-unit wire.

(4) Remove the caps or plugs and connect the suction line to the suction muffler and connect discharge line to the muffler fitting.

**CAUTION: When replacing the compressor assembly, the crankshaft should be rotated by hand at least two complete revolutions to clear oil accumulation from the compressor head before the clutch is ener-**

**gized to avoid damaging the compressor reed valves. IMPORTANT: After the compressor is installed on the engine, the oil level must be adjusted to at least 6 ounces and not more than 8 ounces. (Fig. 7).**

**Oil Level**

When a new compressor is installed at the factory, the compressor contains 10 to 11 ounces of a special wax-free refrigerant oil. While the air conditioning system is in operation, the oil is carried through the entire system by the refrigerant. Some of this oil will be trapped and retained in various parts of the system. Consequently, once the system has been in operation, the amount of oil left in the compressor will always be less than the original charge of 10 to 11 ounces.

**The compressor oil level should be checked as a matter of routine, whenever the refrigerant has been released from the system.**

(1) Operate the system for 15 minutes at 1000 engine rpm. This engine setting will provide a compressor speed of approximately 1200 rpm.

(2) Open car windows and keep engine hood raised.

Engine	Dipstick Reading	
	Inches @ 6 ounces Minimum	Inches @ 8 ounces Maximum
318, 383 & 440 Compressor Set	1-5/8"	2-3/8"
Vertically on Bench	1-5/8"	2-3/8"

(3) Press the A/C button and turn blower switch to high. **On completion of the above operations, shut the air conditioning off, without changing any of the described settings.**

After the system has been bled down, wait ten minutes for refrigerant to boil off and then measure the oil in the compressor by inserting a dipstick (made up as shown in Figure 7) through the crankcase oil

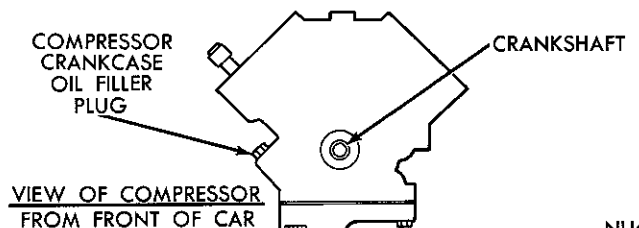
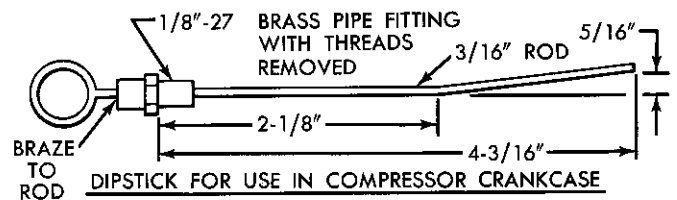


Fig. 7—Compressor Dipstick Chart

filler hole. Measure the height on the dipstick and determine the amount of oil in the unit by referring to the following chart: **Dipstick reading should be at least six ounces and not more than eight ounces.**

If the sump contains less than six ounces of oil, add fresh clean refrigerant oil to bring the level to the minimum shown in the table above. **Remove any oil in excess of eight ounces.**

**CYLINDER HEAD AND VALVE PLATE ASSEMBLY**

**Removal**

(1) Remove the cylinder head bolts, head and valve plate assembly. If plate does not separate from head, tap the removing lip on the valve plate lightly with a plastic hammer (Fig. 8). Do not pry apart.

**Inspection**

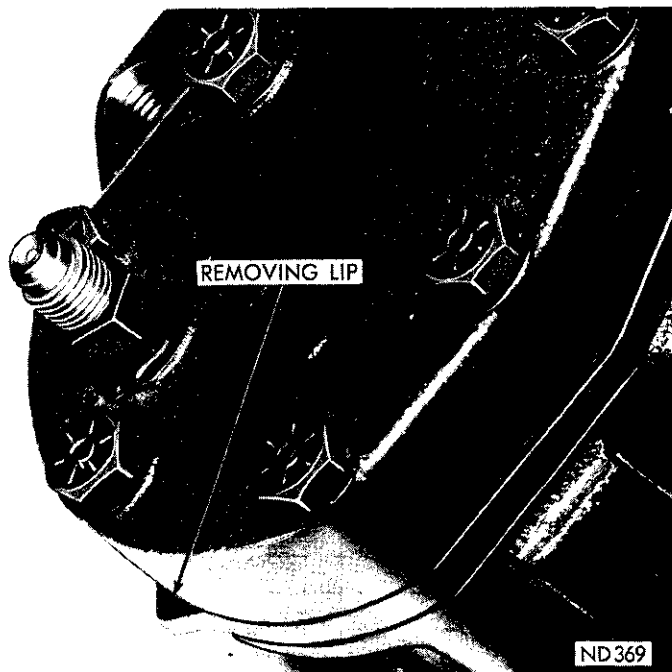
After removal of head, plate and gaskets, examine the valves. If valves are broken and the damage extends to cylinder bores, examine bores to see if they can be repaired by removing light scoring, scuffing or scratches with a crocus cloth. After conditioning cylinder bores, clean surfaces of cylinder block, valve plate and head thoroughly with mineral spirits.

Use care to remove all shreds of old gasket from plate, block and head surfaces. Clean attaching stud holes in the block. If valve plate or cylinder head is damaged, replace, using a complete compressor valve plate replacement package.

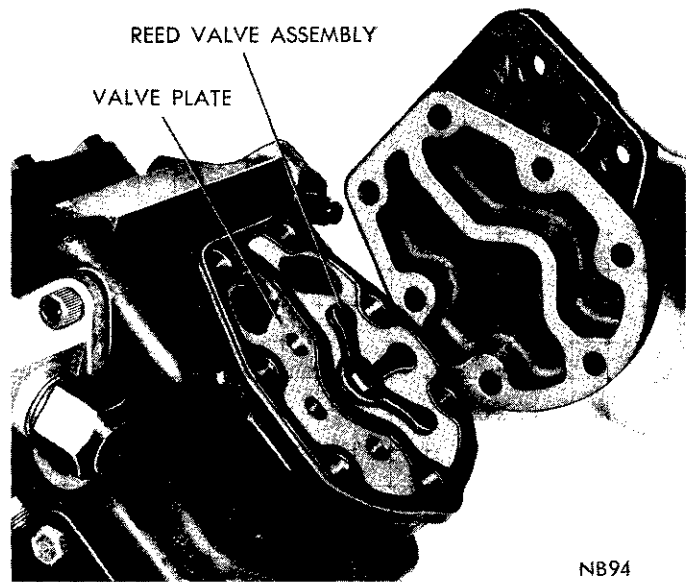
**CAUTION: Do not touch or pry the reed valves.**

**Installation**

(1) The valve plate and the cylinder head must be



**Fig. 8—Valve Plate and Head Removing Lip**



**Fig. 9—Valve Plate—Installed Position**

assembled with the reed valve assembled as shown. (Fig. 9).

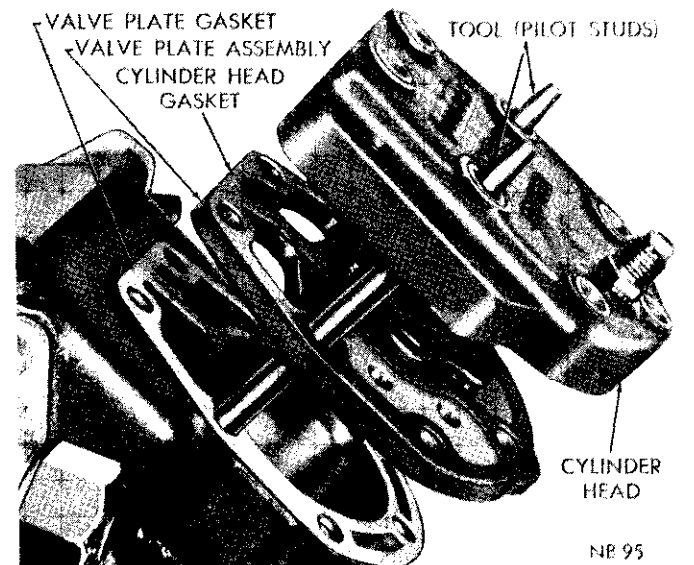
(2) Using the pilot studs as a guide, install the valve plate gasket, valve plate, cylinder head gasket and cylinder head. (Fig. 10).

(3) Install the attaching bolts. Tighten each bolt alternately and evenly 18 to 24 foot-pound (name plate bolts) and 20 to 26 foot-pounds on the remaining bolts.

**PISTON AND CONNECTING ROD**

**Removal**

- (1) Drain oil from compressor.
- (2) Remove sump attaching bolts.



**Fig. 10—Installing the Valve Plate and the Cylinder Head**

(3) Separate the sump from the case by tapping with a plastic hammer being careful not to distort the oil pressure relief spring.

(4) Remove oil relief spring and (rubber) ball from crankcase.

(5) Remove cylinder heads and valve plates. **Before removing the pistons, rods or rod caps, mark all parts to insure reassembly in the original position.**

(6) Remove rod caps; remove piston and rod assembly from cylinder.

### Inspection

Inspect piston and rings for score marks. Inspect rod bearing for pits and for chipping. Replace parts if damaged.

### Installation

(1) Remove bearing cap and install piston in bore. Use piston ring compressor to prevent ring damage.

(2) Install bearing caps, and tighten screws 50 to 60 inch-pounds. Be sure each cap is installed in its original position.

(3) Install valve plates and cylinder heads.

(4) Turn compressor upside down. Install pilot studs, gasket, oil pressure relief ball and spring.

(5) Install the sump over pilot studs (Fig. 11), making sure the oil pressure relief spring depresses uniformly as the sump is lowered on the case.

(6) Tighten sump bolts finger tight to prevent spring misalignment, then tighten 14 to 20 foot-pounds.

(7) Refill with new refrigerant oil after the compressor is installed on vehicle. Do not re-use the oil that was previously drained.

## CRANKSHAFT BEARING HOUSING AND GAS SEAL

### Replacement (System Discharged)

The gas seal may be replaced with the compressor installed in the vehicle or with the compressor removed and placed on a workbench.

Special care should be taken when installing the new seal in a compressor mounted on the engine, that the carbon ring does not fall out of its housing. Ade-

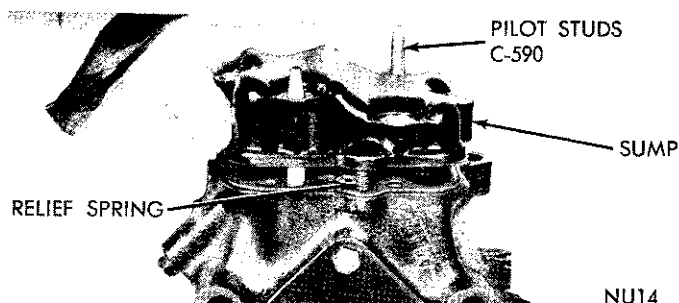


Fig. 11—Installing the Compressor Sump

quate lubrication of the rotating seal assembly prior to installation on the compressor shaft, will prevent the carbon ring from falling out of place.

If the compressor has been removed from the vehicle, it should be placed on its back, to facilitate seal replacement.

The crankshaft gas seal replacement package consists of the crankshaft gas seal assembly and crankshaft bearing housing seal seat plate. Two types of crankshaft seals are supplied for service (Fig. 13). If the replacement package contains the cartridge-type seal, follow the entire installation procedure given below. If the replacement package contains the unitized type seals, follow the appropriate sections only.

### Removal

(1) Loosen belt, remove clutch, coil and drive key.

(2) Remove crankshaft bearing housing seal bolts.

(3) Remove bearing housing from crankshaft, using two screwdrivers inserted in the slots provided, to pry the housing from the case (Fig. 12).

(4) Remove bearing housing oil seal.

(5) Remove gas seal seat plate from the bearing housing. This is part of the gas seal replacement package and must be replaced when the gas seal assembly is replaced.

(6) Clean the front bearing housing thoroughly.

### Installation

(1) Immerse the new seal seat in clean refrigerant oil and install in the bearing housing with the smooth (micro finish) side up. Use a sleeve with the minimum inside diameter of 1-3/8" to avoid damaging the micro finish sealing surface of the face plate. Tap the sleeve lightly until the seal seat is fully seated in the housing.

(2) Before installing the cartridge-type assembly, inspect the assembly to make sure that the tangs of the carbon seal are indexed in the slots of the mating, steel part (Fig. 13).

(3) Immerse the seal assembly in clean refrigerant oil, carbon ring up.

(4) Hold the seal assembly firmly at the outside edge, at the same time preventing the ring from coming out of position. Do not touch the sealing face of the carbon seal.

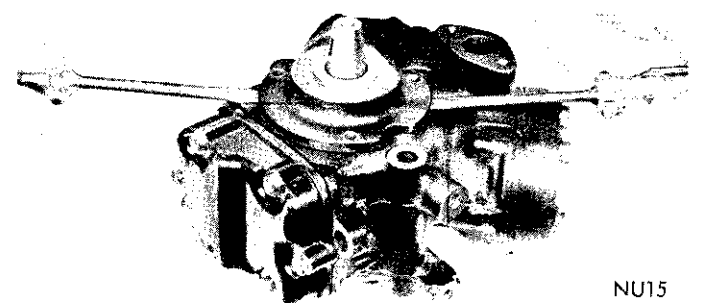
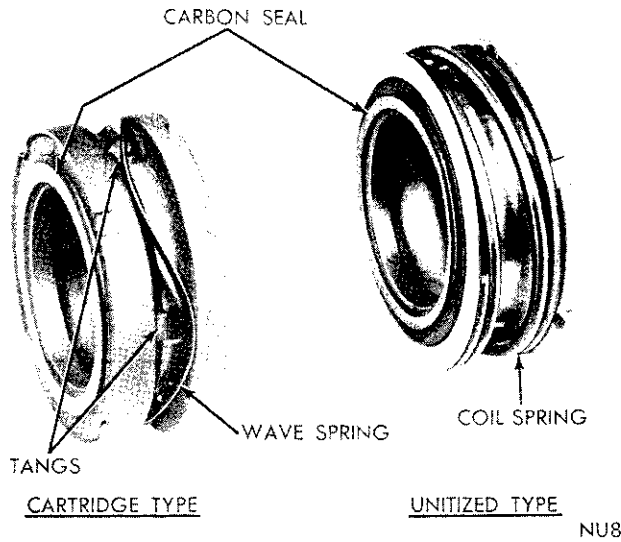


Fig. 12—Removing the Crankshaft Bearing Housing





**Fig. 13—Gas Seal Identification**

(5) When the seal bottoms against the crankshaft bearing, inspect the indexing tangs of the carbon ring again.

(6) Oil the bearing housing oil seal and install. (Make certain that the seal is evenly stretched into position.)

(7) Wipe the seal seat clean with a lint-free cloth, and re-oil with refrigerant oil.

(8) Install the bearing housing, taking care to ensure that the “nose” of the crankshaft does not touch the seal seat in the bearing housing.

(9) Insert 5, 1/4 x 20 screws and pull bearing housing squarely into position. This must be done 1/2 turn at a time per screw so that the ball bearing outer race will not be jammed by the bearing housing.

(10) Replace drive key in shaft.

(11) Assemble clutch to compressor and turn crankshaft by turning clutch armature. No more than 10 inch-pounds of torque should be required to turn crankshaft. If shaft is tight, remove clutch and loosen the bearing housing screws until shaft loosens up. Again, slowly tighten screws.

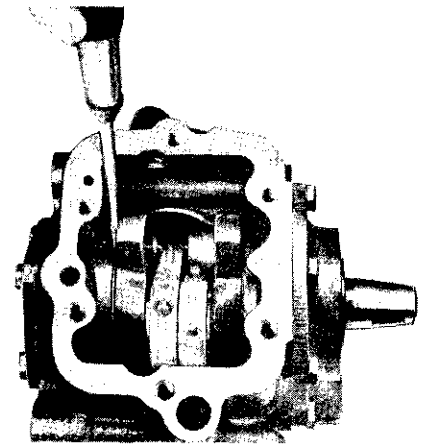
(12) Check the oil level which should meet the requirements of the oil check.

(13) Install clutch package on compressor, applying 20 ft-lbs. torque to tighten the clutch center mounting bolt. Install and tighten belts. Evacuate system and recharge.

## CRANKSHAFT AND BALL BEARINGS

### Removal

- (1) Remove cylinder heads and valve plates.
- (2) Remove pistons and connecting rods.
- (3) Remove crankshaft bearing housing and gas seal. **The pistons and rods must be completely removed before the crankshaft removal.**



**Fig. 14—Measuring Crankshaft Axial Movement**

(4) Remove crankshaft and thrust washer from crankcase.

(5) To remove the crankshaft ball bearing, use a small arbor press. Make sure bearing is properly supported before pressing bearing from shaft.

### Inspection

Clean and inspect all the parts. Replace questionable parts as required. If the crankshaft ball bearing is in good condition and clean, protect it against entry of dirt and re-use it. If bearing is serviceable but dirty, or there is evidence of dirt, clean it carefully with mineral spirits and shake dry. Saturate bearing with clean refrigerant oil and assemble immediately. If a new bearing is to be installed, leave it wrapped in its protective package until ready for installing. **Do not wash a new bearing assembly before installation. Do not spin bearing with air.**

### Installation

(1) Press crankshaft ball bearing on crankshaft using a sleeve which bears on inner race **only**.

(2) Install crankshaft, making sure the thrust washer is on the rear bearing journal before placing crankshaft in the crankcase.

(3) Rotate crankshaft to engage the oil pump shaft in the crankshaft slot.

(4) Install new gas seal and crankshaft bearing housing. Use a suitable tool, as shown in Fig. 14 to assure free axial movement.

(5) Install pistons and connecting rods.

(6) After pistons and connecting rods are installed, turn the crankshaft to check freeness. Shaft should turn without binding.

(7) Install oil sump, valve plates and cylinder heads, using new gaskets.

## OIL PUMP

### Removal

To remove oil pump, it is not necessary to drain the refrigerant oil from the crankcase.

- (1) Remove oil pump cover plate and oil seal.
- (2) Remove drive shaft and rotors.

**Installation**

- (1) Install oil pump drive shaft by rotating the shaft until tang end engages in the crankshaft slot.
- (2) Install inner rotor on the drive shaft, engaging

the drive.

- (3) Install outer rotor, and rotate it until it will slide forward over inner rotor cams. Turn compressor crankshaft with the oil pump in this position to determine that rotors do not bind.
- (4) Install oil pump cover plate and oil seal.
- (5) Tighten bolts 8 to 14 foot-pounds.

**EVAPORATOR HEATER ASSEMBLY**

**INDEX**

	Page		Page
Blower Motor Removal and Installation .....	42	Heater Core Removal and Installation .....	41
Electrical Controls and Circuits .....	37	Linkage Adjustment .....	40
Evaporator Removal and Installation .....	42-44	Operation of All Controls .....	38
Expansion Valve Removal and Installation .....	40	Vacuum Controls and Circuits .....	36
General Information .....	34		

**GENERAL INFORMATION**

**Imperial—Installations**

Two types of original equipment air conditioner options are available. The first option is the Automatic Temperature Control System which automatically controls the heating and air conditioning operation of the vehicle to maintain a selected interior temperature. In cold weather, the system provides heat as soon as the warm air is available. When outside temperature increases, the system provides cool dehumidified air.

The unit will heat or cool according to ambient temperature, interior temperature, and control setting; in varying degrees of either heating or cooling without any action on part of operator other than dialing desired temperature and setting system on "Auto".

The basic air conditioning package has not changed. The controls have changed and various sensor components have been added.

The second option is a dual installation consisting of the combination front unit and a rear unit. The rear unit evaporator assembly is mounted in the luggage compartment. This deluxe installation insures equal distribution of conditioned air to rear seat as well as front-seat passengers.

The dash-mounted front unit is the basic factory installed option. The rear unit, mounted in the luggage compartment is not available as a single unit without the front unit. Since the rear unit option operates automatically in conjunction with the front unit, only the front unit will be described in detail in the Automatic Temperature Control (Auto-temp) section of this manual.

**Trunk Unit Control (Imperial)**

The trunk unit evaporator is dependent upon the controls used to operate the front unit. The evapo-

rator of a trunk unit of a dual installation will cool only when the "MAX. COOL" or the "FR. COOL" push button of the front unit control is depressed to energize the magnetic compressor clutch.

The blower circuit of the trunk unit is entirely independent of the front unit. See "Wiring Diagrams" Section 8 of this Manual.

**Chrysler—Installations**

Three air conditioner options are available. The first option (Front Unit) (Fig. 1), is a combination air conditioning and heating unit contained in two housings separated by the dash panel. The evaporator and heater core are inside the housing installed under the instrument panel. This housing is called the "Passenger Side Housing". The blower motor and time delay relay are installed on the housing attached to the engine side of the dash panel. This housing is called the "Engine Side Housing". The controls and cooling air outlets are integral with the instrument panel (Fig. 2). This system functions on the reheat principle.

In the "reheat" air conditioner unit all the air entering the system passes through both the evaporator coil and the heater core, regardless of whether the heater, defroster or air conditioning is in use. All output air temperatures are controlled by a single slide lever in the instrument panel, which operates the heater water flow control valve through a vacuum regulator. Airflow is controlled and directed through the unit by a series of doors operated by vacuum actuators and mechanical linkages. The blower is turned on by any of four push buttons.

The second option is the Automatic Temperature Control System (Auto-Temp) which automatically controls the heating and air conditioning operation of the vehicle to maintain a selected interior temperature. In

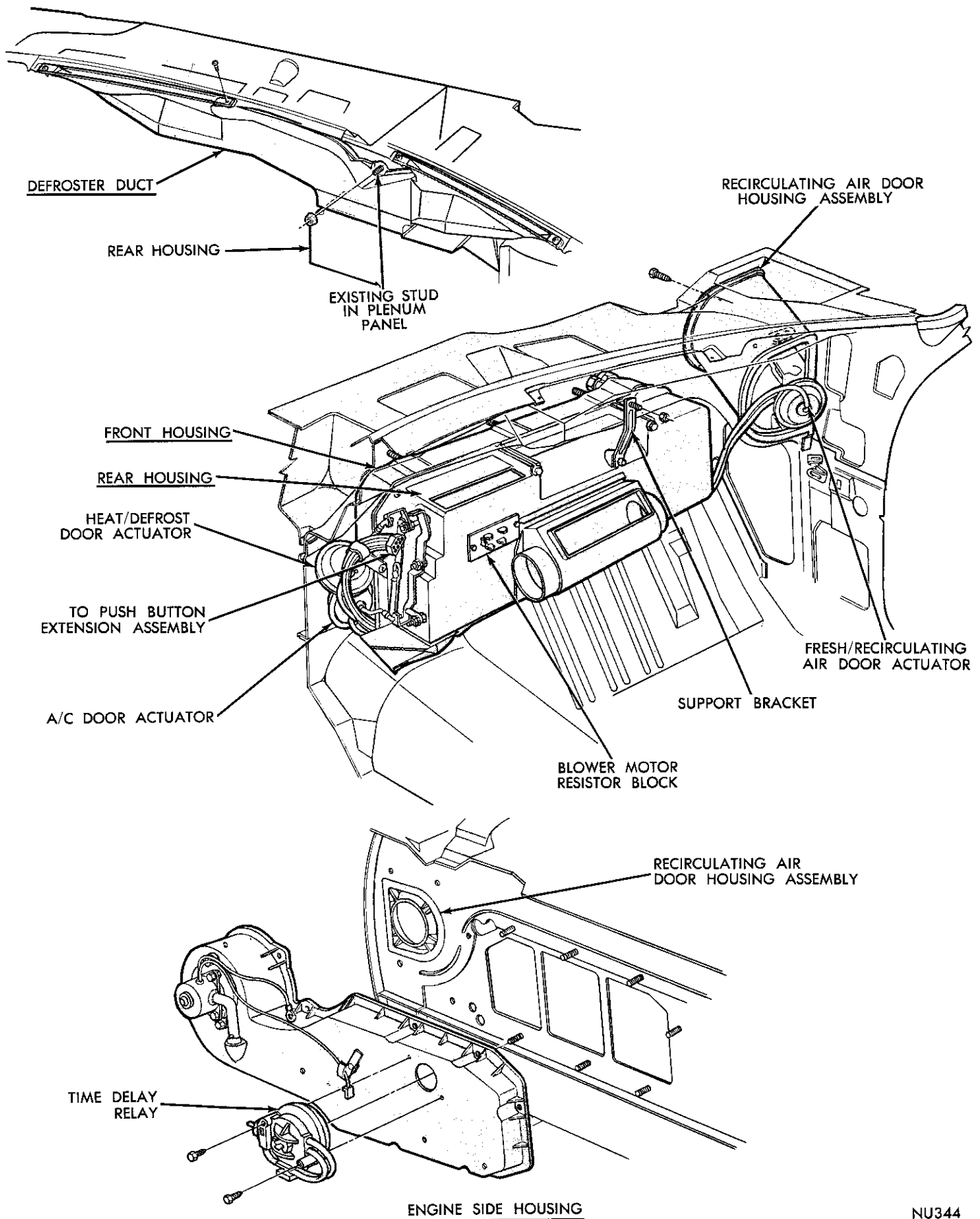


Fig. 1—Air Conditioner Heater Assembly

cold weather, the system provides heat as soon as the warm air is available. When outside temperature increases, the system provides cool dehumidified air.

The unit will heat or cool according to ambient temperature, interior temperature, and control setting; in varying degrees of either heating or cooling without any action on part of operator other than dialing desired temperature and setting system on "Auto."

The basic air conditioning package has not changed. The controls have changed and various sensor components have been added and are described in detail in the "Auto-Temp" Section of this manual.

The third option (Station Wagons Only), includes the first or second option plus a roof mounted evaporator assembly.

The roof mounted unit operates automatically in conjunction with the front unit and is not available as a single unit without the front unit.

Controls for the front system (Standard A/C) consists of five push buttons, a temperature control slide lever and a three-position toggle-type fan blower switch.

Control for the roof mounted system consists of a rotary two speed switch.

**Push Buttons**—Control the source and route of

circulating air. "Off" (turns off system); "MAX A/C" (maximum air conditioning); "A/C" (fresh air—air conditioning); "HEAT" (for heater use only); "DEF" (windshield defroster).

**Temperature Control Slide Lever**—Maintains any desired temperature by sliding the lever right or left when operating either the heater or air conditioner.

**Fan Switch**—Permits selection of low, medium or high blower speeds. "LO" (far left); "MEDIUM" (center) and "HI" (far right) used when operating either the heater or air conditioner.

**Air Directional Vanes**—One at each end, and two in the center of the instrument panel. These are adjusted manually to direct cool air to suit the requirements of the driver and passengers.

The center outlets are units that can be rotated to direct air up or down; adjustable vanes direct air to either side (Fig. 2).

The outlets at each end of the instrument panel are also adjustable or can be shut-off by a damper operated by a vertical slide lever or a horizontal slide lever depending on car model.

### VACUUM CONTROLS AND CIRCUITS

When testing or adjusting the doors in the distribution system, it is necessary to know the correct posi-

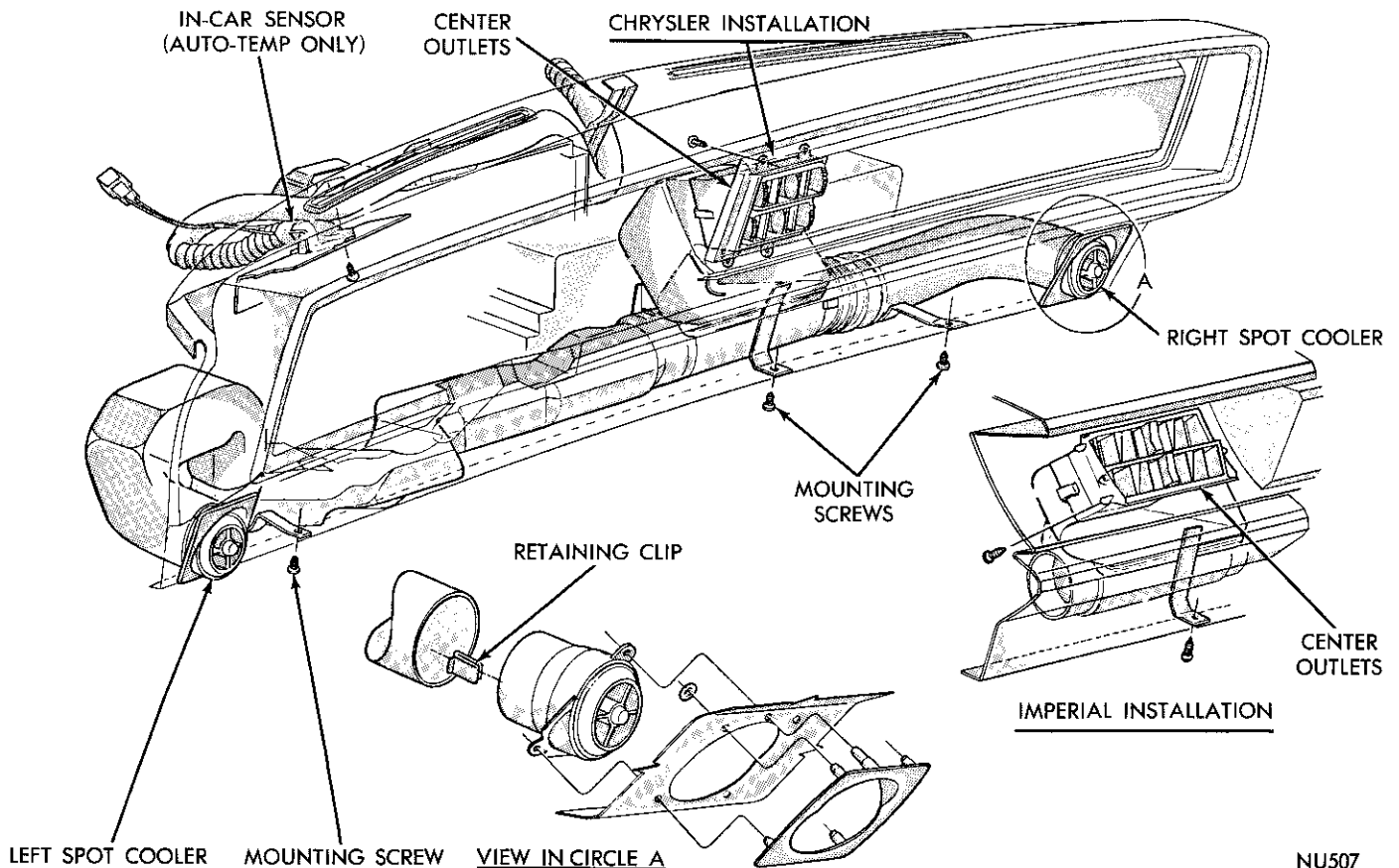


Fig. 2—Air Conditioning Ducts

tion of each door for each push-button position. It is also necessary to know which vacuum hoses are activated for each push-button position. In the following illustrations air flow is indicated as the vacuum actuator hoses are activated for each push-button position (Figs. 3 through 7).

**Ventilation**

While driving, outside air can be brought into the interior through the inlets in the side cowls. These inlets are opened by pulling the control knobs located on the lower edge of the instrument panel on both sides of the steering column. The knob to the left of the column controls the air inlet on the left side of the car and the right hand knob controls the right side. The amount of air intake is regulated by the distance the knobs are pulled out. Pushing the knobs all the way in closes off the air intake. **Be sure the air intake controls are pushed all the way in before operating the air conditioning system.**

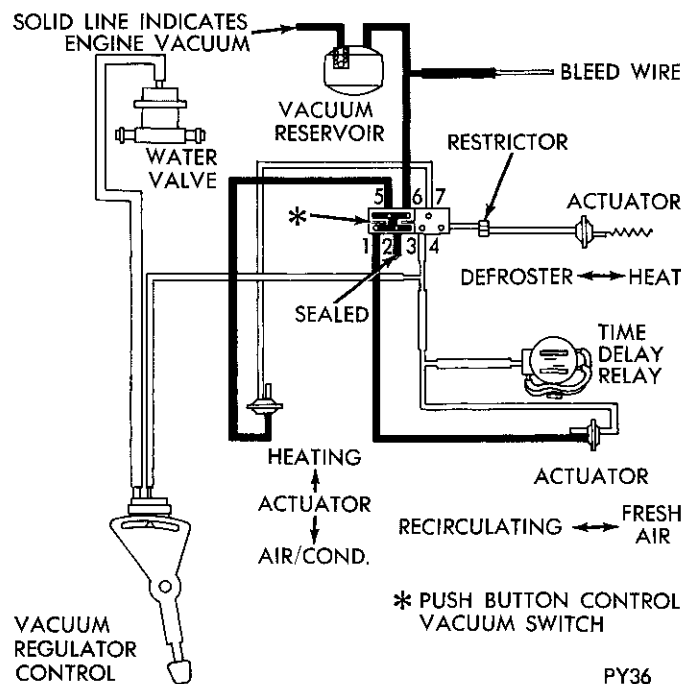
**ELECTRICAL CONTROLS AND CIRCUITS**

There are two switches, a push button switch (air conditioner and heater vacuum switch), and a fan switch (air conditioner and heater blower switch).

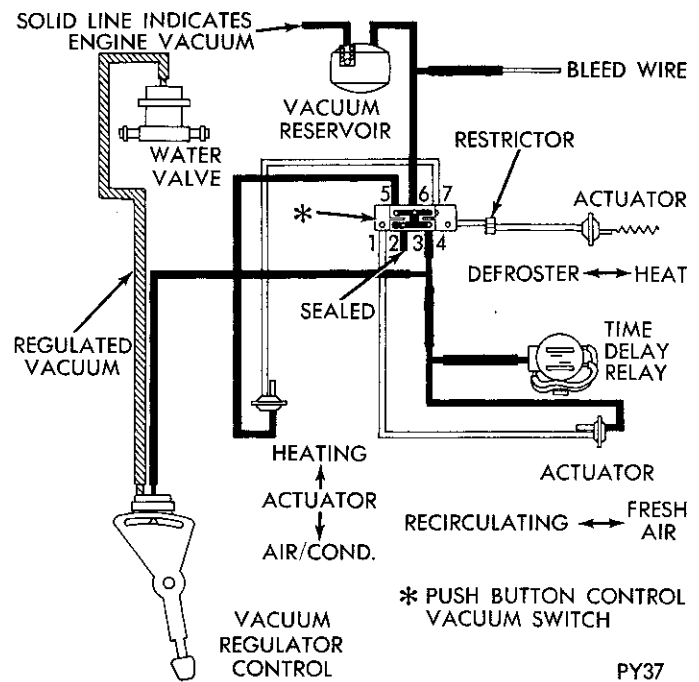
**Push Button Control**

The power feed circuit is shown in Figure 7. A 20 ampere fuse in the fuse block protects the circuit.

The compressor clutch circuit is energized when either the "MAX. A/C" (maximum air conditioning) or the "A/C" (fresh air—air conditioning) push but-



**Fig. 3—Vacuum Circuit—Off-Max. A/C Position**



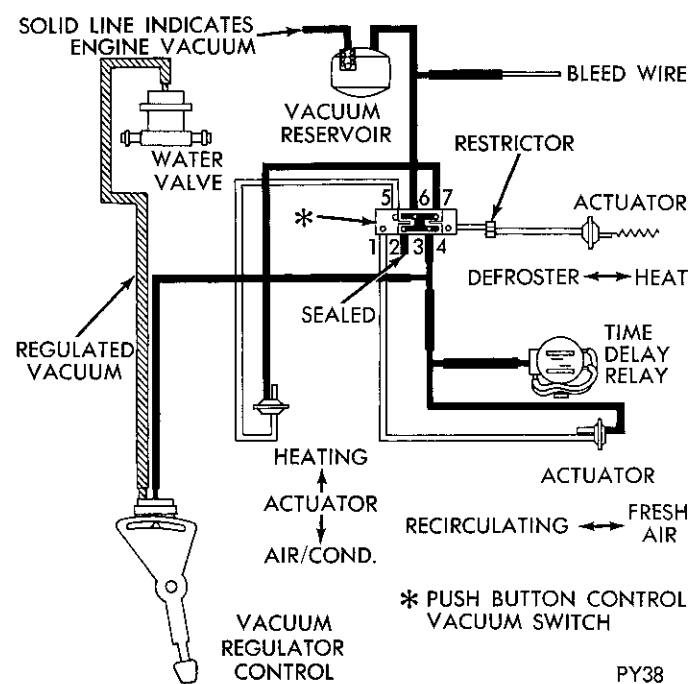
**Fig. 4—Vacuum Circuit—A/C Position**

tons are depressed. The "OFF" button turns off the system.

**Blower Motor (Fan Switch)**

The power feed line from the push-button switch to the blower switch is energized only when the ignition is on and any push button, other than "OFF," is depressed.

The switch is controlled by moving the control lever in or out.



**Fig. 5—Vacuum Circuit—Heat Position**

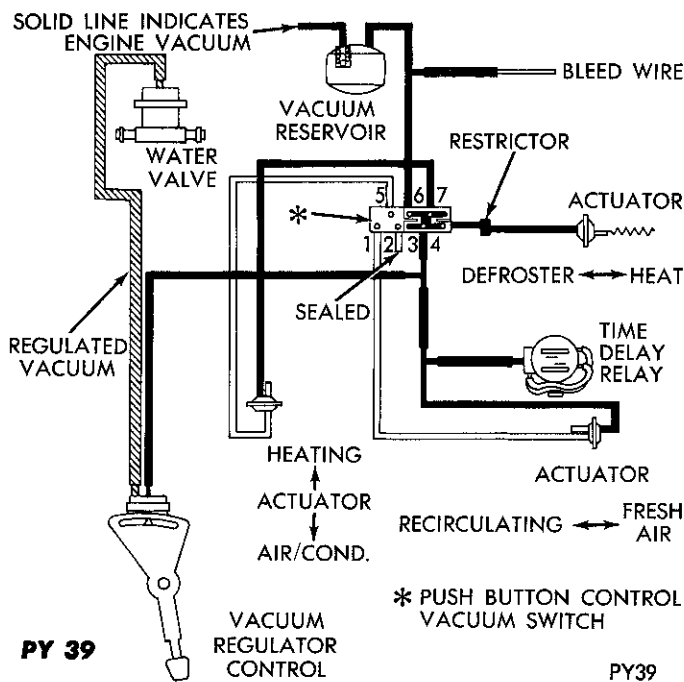


Fig. 6—Vacuum Circuit—Defrost Position

**OPERATION OF ALL CONTROLS**

Satisfactory performance of the combined air-conditioning and heating system is dependent upon

proper operation and adjustment of all operating controls, as well as proper functioning of all refrigeration system units. The inspections, tests and adjustments should be used to locate the cause of a malfunction. The inspections and tests in this manual have been arranged in a logical sequence that has proved to be the surest and shortest route to accurate diagnosis. It is recommended that they be followed and performed in the order in which they are presented.

Operating controls must be tested in the following sequence.

- (1) Inspect and adjust compressor drive belt.
- (2) Open vehicle windows.
- (3) Move temperature control slide lever to "Off" position.
- (4) Start engine and adjust engine speed to 1130 rpm. Use a reliable tachometer.
- (5) Push the "A/C" button in.
- (6) Fresh-recirculating door should be open to fresh air.
- (7) Test the blower operation at all three speed positions. If the blower does not operate correctly, refer to "Electrical Controls and Circuits." Leave the blower switch in the "Low" position.
- (8) The compressor clutch should be engaged, the compressor operating, and the air conditioning system in operation. If the clutch does not engage, test

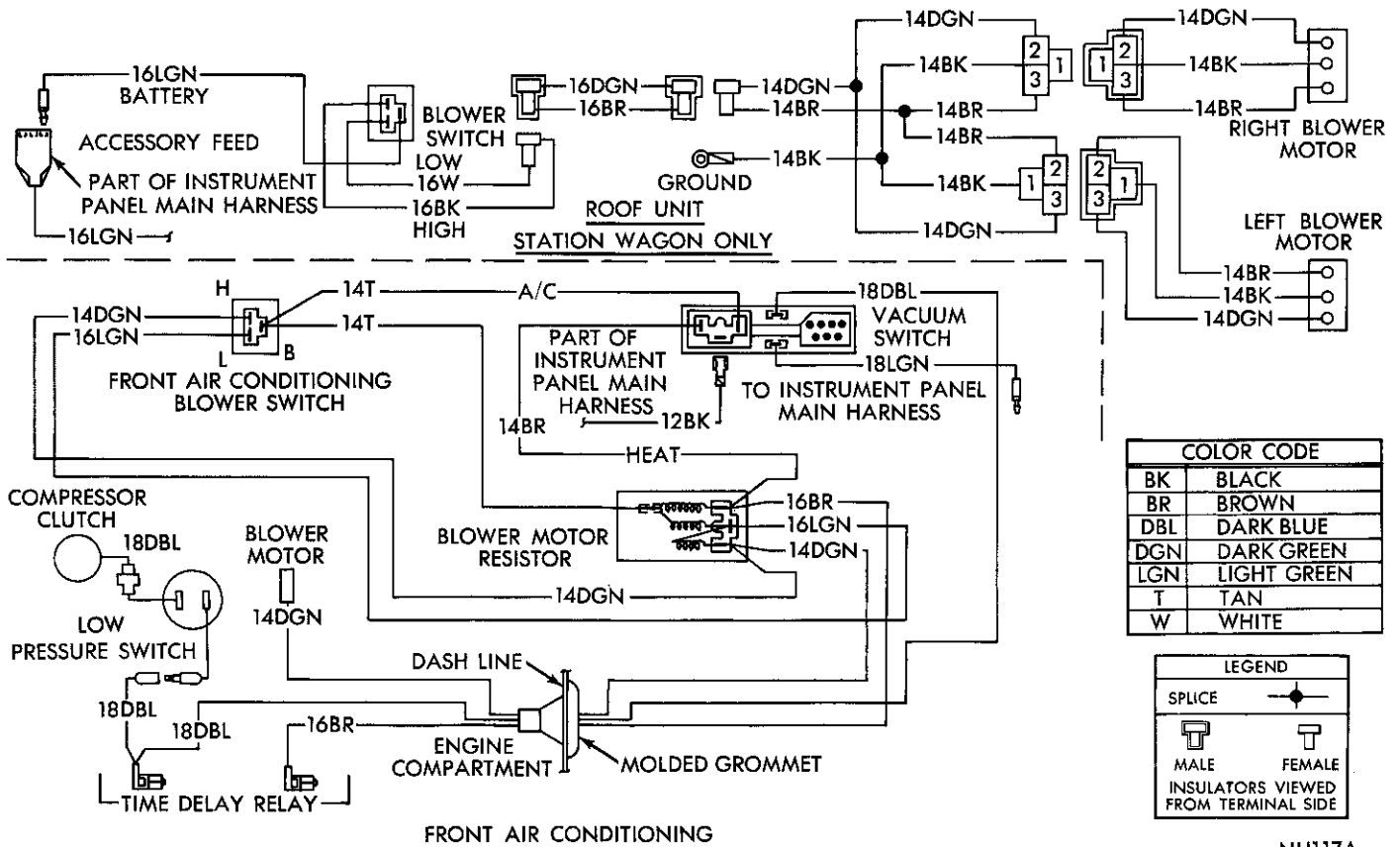


Fig. 7—Electrical Control Circuits

the circuit as outlined under "Electrical Controls and Circuits."

**Push Button Operation**

Reduce the engine speed to normal idle. With the engine operating at idle speed, the vacuum will be high and the vacuum actuators should operate quickly.

If the actuator operation is slow, check the source hose connection at the engine manifold.

Push each button to test the over-all operation of the electrical and vacuum controls.

The "Push Button Control Chart" summarizes the actions that should take place when each button is pushed. See "Chart." Also refer to "Vacuum Controls and Circuits."

If all the controls operate in the proper sequence but the action of the dampers and doors is slow or incomplete, inspect for mechanical misalignment, binding or improper linkage adjustment.

**Time Delay Relay**

A vacuum actuated time delay relay is located on the face of the engine side housing in the engine compartment. The purpose of this relay is to reduce the interior windshield condensation to an acceptable level.

When the ambient temperature is above 25 degrees, and the heat or defrost buttons are pressed, the air conditioner will go on for a period of 2 to 10 minutes.

If the system is shut down for less than 10 minutes no delay will occur upon restarting. The relay will reset automatically after 10 minutes shut down.

**Restrictor**

The time delay system includes, in addition to the time delay relay, a plastic restriction in the vacuum hose leading to the heater door actuator. This restric-

tor provides some delay in the opening of the defroster door after the "HEAT" or "DEFROST" button is depressed. This delay gives the blower time to expel condensation from the evaporator housing through the heater outlets before it can be blown up onto the windshield.

Should it become necessary to replace the vacuum hose leading to the heater door actuators, the correct restrictor should be used.

**Vacuum Actuated Water Valve**

The water temperature control valve is operated by engine vacuum which is modulated by a regulator on the back of the temperature control lever (Fig. 8).

When the control lever is in the off position, 0 to 1 inch of vacuum will be present at the water valve and no water will flow through the heater core.

With the control lever placed in the center position, vacuum at the water valve should read 8 inches + or - 1/2 inch and a moderate amount of water will flow through the heater core.

Movement of the control lever to the extreme right (Heat) position allows 14-1/2 inches to 16 inches of vacuum through the regulator and full water flow through the heater core.

**Vacuum Reservoir Tank**

A vacuum reservoir tank is used to maintain sufficient vacuum in the system in cases where source vacuum is lost momentarily. The tank has a check valve at the inlet port which closes when the vacuum drops off. (Fig. 8).

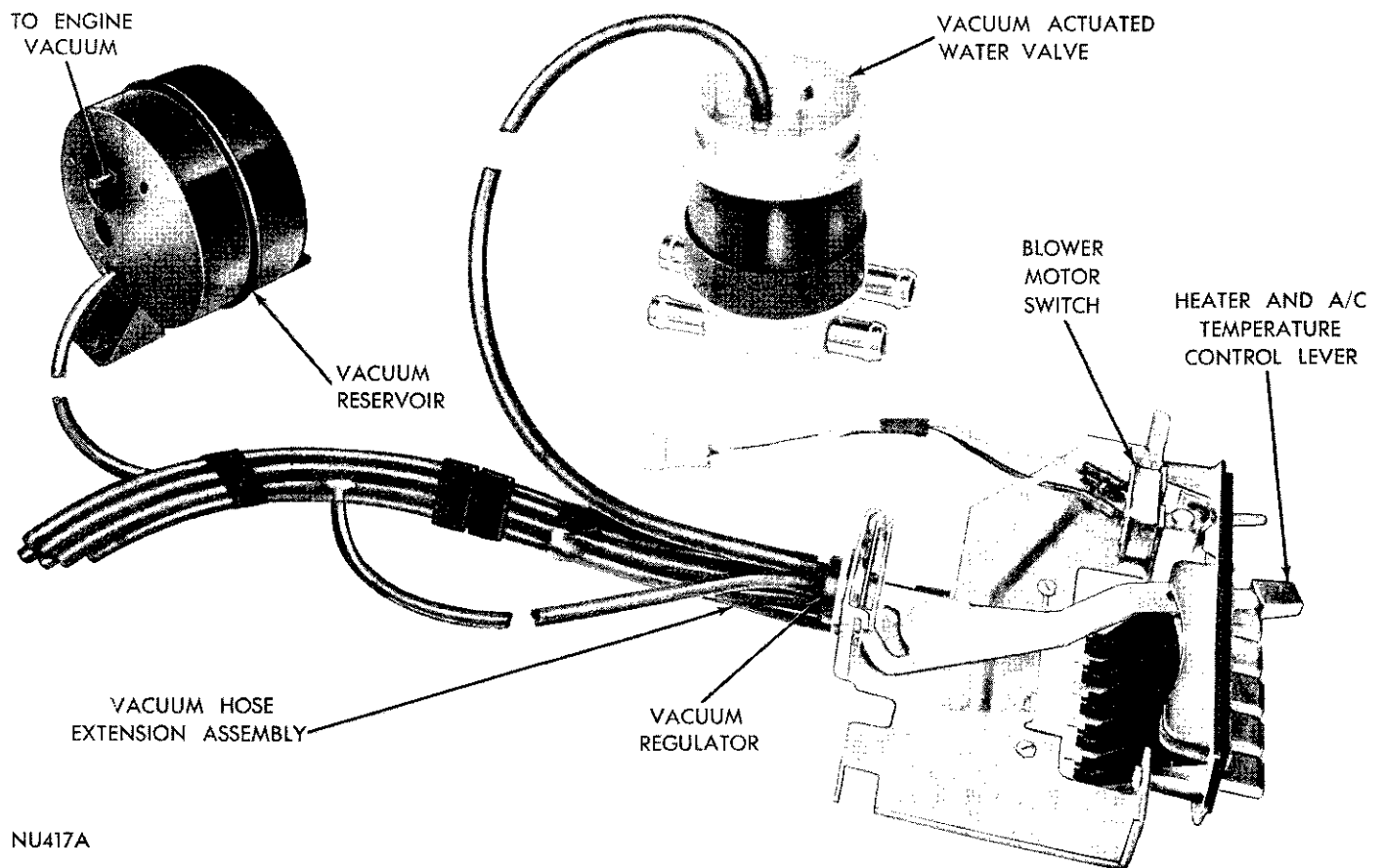
Operation of the tank and check valve can be tested in the following manner:

- (1) Connect a 0-29 inch Hg. vacuum gauge to outlet port of tank.
- (2) Start engine and allow to run at idle speed.
- (3) Vacuum at gauge should build up to within 2 inches of engine vacuum in less than one minute.

**PUSH BUTTON CONTROL CHART**

Button	Off	Max. A/C	A/C	Heat	Defrost
FRESH AIR DOOR	Closed	Closed	Open	Open	Open
RECIRCULATING DOOR	Open	Open	Closed	Closed	Closed
AIR CONDITIONING DOOR	Open	Open	Open	Closed	Closed
HEATER DOOR	Closed	Closed	Closed	Open	Closed with Air Bleed
DEFROSTER DOORS	Closed	Closed	Closed	Closed with Air Bleed	Open
BLOWER SPEED	Off	Hi.-Med. Lo	Hi.-Med. Lo	Hi.-Med. Lo	Hi.-Med. Lo
COMPRESSOR CLUTCH	Off	On	On	*Off	*Off

\*Compressor will be ON for a period of 2 to 10 minutes when ambient temperature is above 25°.



**Fig. 8—Vacuum Controls (Chrysler)**

(4) Shut engine off, and observe gauge.

(a) If vacuum does not drop off, the check valve and tank are operating satisfactorily.

(b) If vacuum drops off, there is a leak and tank assembly should be replaced.

### Linkage Adjustment

Adjusting gauges can be made as shown in Fig. 9. The Heater door bleed gauge is made from a short length of welding rod with a flat washer soldered at a right angle to the rod 5/16 of an inch down from the end. The Defrost door bleed gauge is an 8 inch piece of 3/8 inch O.D. copper tubing bent to 60 degrees as illustrated.

### Defrost Door Bleed Adjustment

Place the system in "Heater" mode, loosen the nut on the defroster door shaft. Insert the 3/8" gauge on the unit between the defroster door and the rear wall of the rear A/C housing as shown on Fig. 9. Tighten the nut on the defroster door shaft. Remove gauge.

### Heater Door Bleed Adjustment

Place the system in "Defrost" mode, loosen nut on adjustable link (heater door spring will cause heater door to open). Insert adjusting gauge through rear most rectangular slot (Fig. 9) in heater distribution

duct so that collar on the gauge rests on the edge of the heat door. Push the door to the bleed position 5/16 inch until tip of the gauge is bottomed on the floor of rear housing. Push slotted (lower) link toward heat duct until lower slot bottoms on shoulder rivet and tighten adjustable link screw. Remove gauge.

### EXPANSION VALVE

#### Removal

The system must be completely discharged before opening any of the refrigerant lines.

(1) Disconnect equalizer from suction line fitting (Fig. 12).

(2) Disconnect expansion valve from liquid line and evaporator. Use two wrenches to loosen each of these connections.

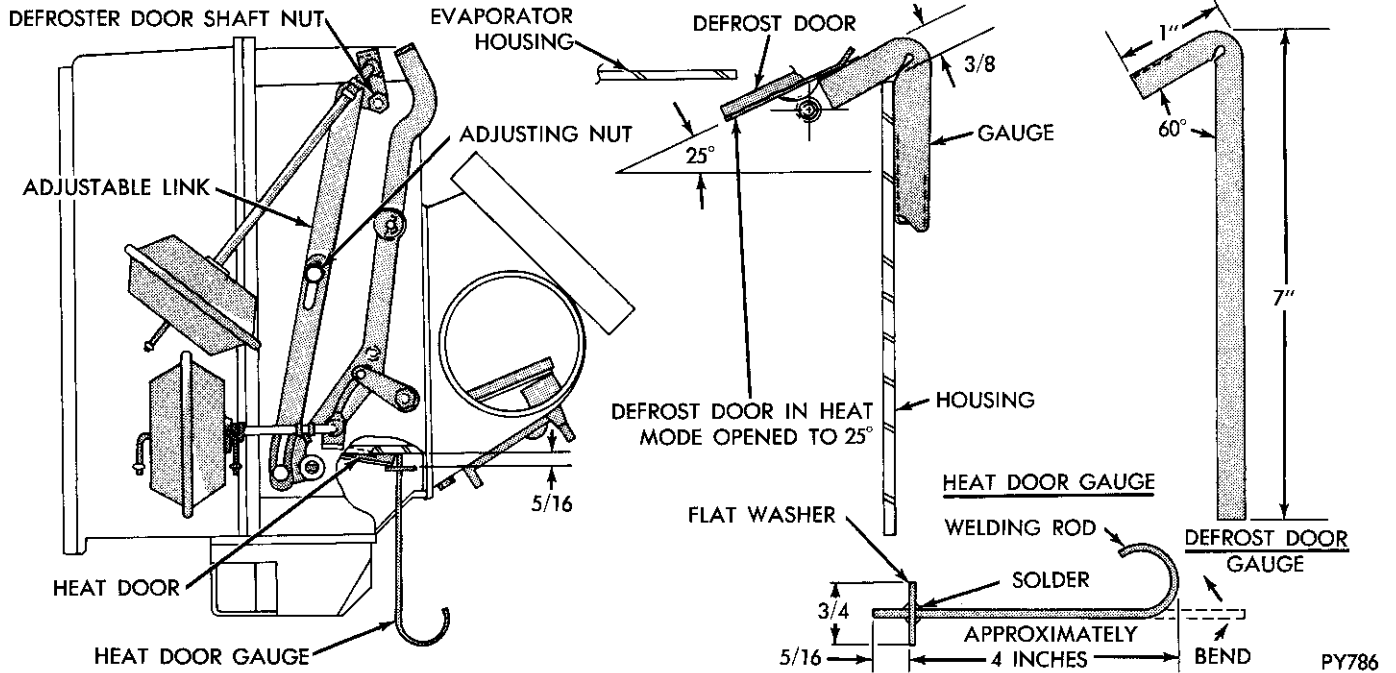
(3) Carefully pull out capillary sensing tube from suction line well.

(4) Remove rubber seal from the capillary sensing tube. Inspect condition of inlet screen.

#### Installation

(1) With new "O" rings and clean refrigerant oil on all fittings, connect expansion valve to liquid line and evaporator assembly using two wrenches to prevent rotation and twisting of the lines.





**Fig. 9—Linkage Adjustment**

- (2) Connect equalizer tube to the fitting on suction line.
- (3) With a rubber seal on the capillary sensing tube, carefully insert the tube in the suction line well as far as it will go (approximately five inches).
- (4) After expansion valve is installed, it must be completely tested and the system must be tested for leaks and recharged.

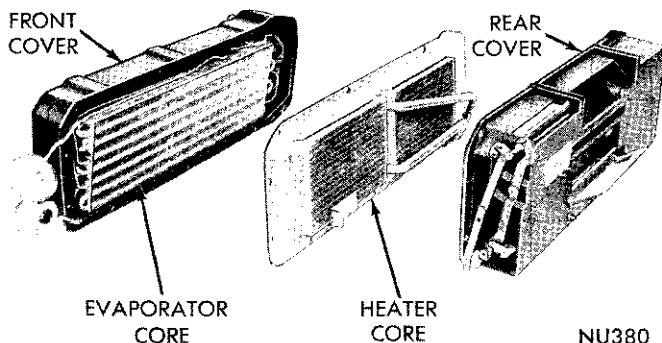
**HEATER CORE**

**Removal (Fig. 10)**

The heater core is located in the front cover of the passenger side housing. To remove the heater core **only**, the air conditioning system need not be discharged or disconnected.

- (1) Disconnect negative battery cable, drain cooling system, remove air cleaner and disconnect heater hoses.
- (2) Plug both heater core tubes to prevent spilling coolant when core is removed.

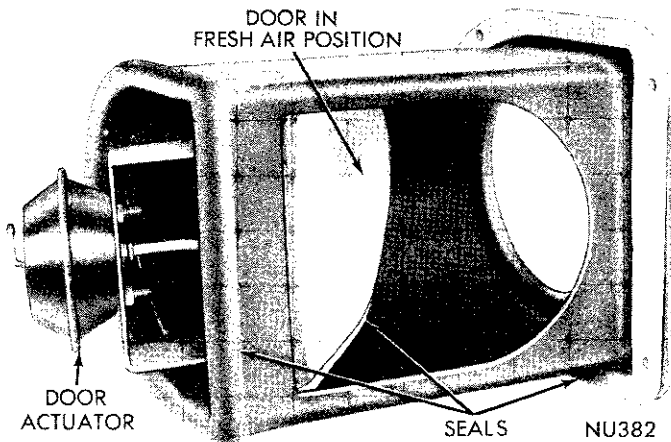
- (3) Remove steering column cover and left spot cooler duct.
- (4) Disconnect two actuator rods at linkage on left side of housing, and remove two cover retaining screws.
- (5) Remove five screws retaining heat distribution duct. When heat duct is removed, three screws in bottom lip of front cover will be exposed, remove these screws.
- (6) Remove glove box and remove center spot cooler, air distribution housing and right spot cooler duct.
- (7) From glove box opening, remove two top retaining screws and three screws from right side of housing.
- (8) Disconnect wires at resistor block and vacuum hoses from recirculating housing actuator.
- (9) Remove nut from housing end of support bracket and swing bracket up out of the way, carefully roll front cover and heater core out from under instrument panel.



**Fig. 10—Heater and Evaporator Core—Passenger Side**

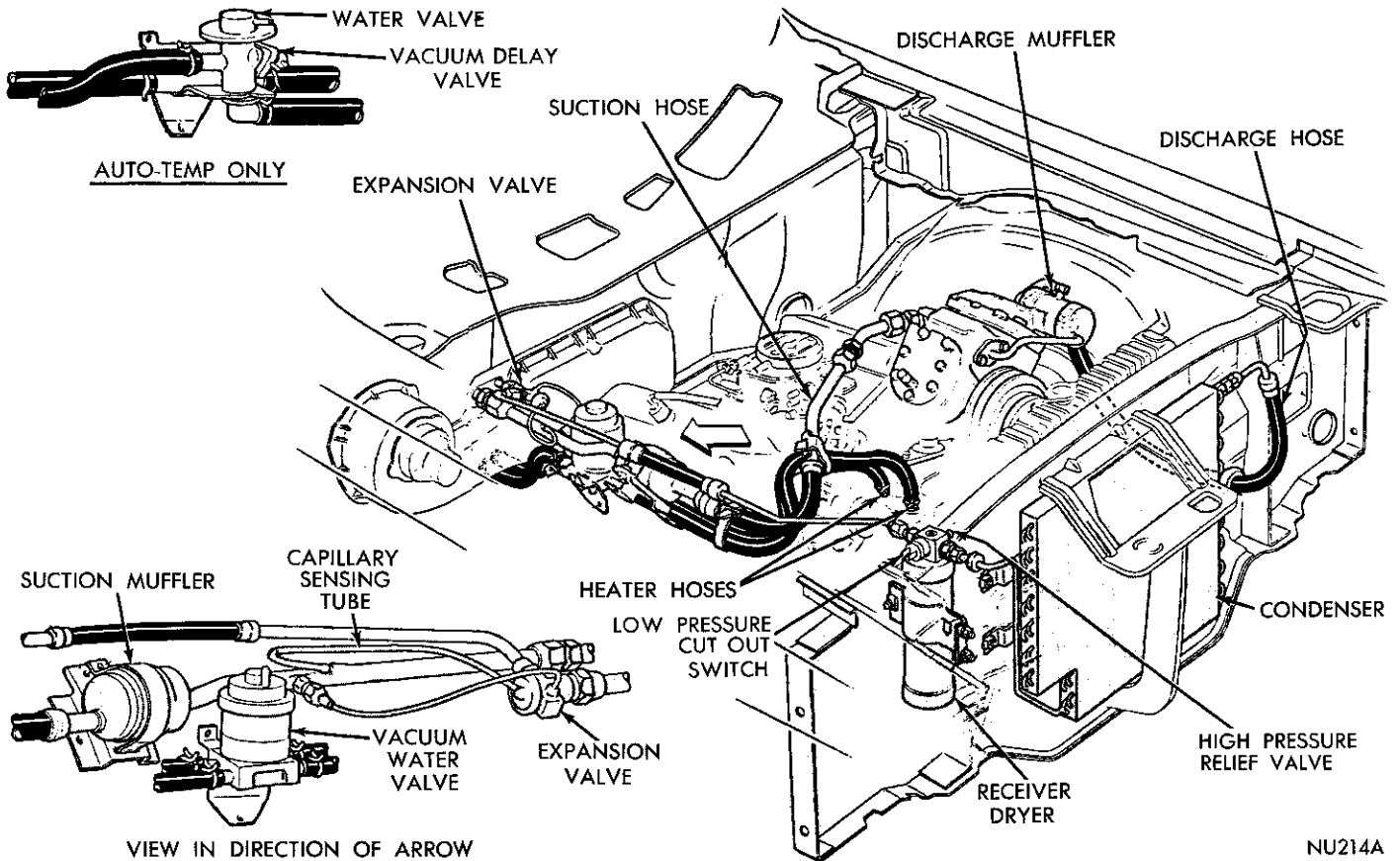
**Installation**

- (1) Place heater core in front cover and position core and cover on evaporator housing. Hold front cover in place and swing support bracket down over existing stud on face of front cover. Install retaining nut.
- (2) From glove box opening, install two top housing retaining screws and three screws at right side of front cover.
- (3) From under instrument panel, install five remaining screws surrounding housing.



**Fig. 11—Fresh Air-Recirculating Door Housing**

- (4) Install heat distribution duct to bottom of housing.
- (5) Connect actuator rods.
- (6) Connect all vacuum hoses to actuators and electrical connectors to resistor block.
- (7) Install air distribution housing, center spot cooler duct and right spot cooler duct through glove box opening.
- (8) Install steering column cover and left spot cooler duct. Install glove box assembly.
- (9) Connect heater hoses and fill cooling system.



**Fig. 12—Air Conditioning and Heater Plumbing (383-440 Engines)**

For summer operation as well as winter operation, be sure the system is protected with the proper type and amount of anti-freeze.

(10) Install air cleaner and connect battery ground cable.

(11) Start engine, operate until normal engine operating temperature is obtained and test operation of heater.

### BLOWER MOTOR

The blower motor is mounted to the engine side housing under the right front fender between the inner fender shield and the fender. The inner fender shield must be removed to service the blower motor, recirculating housing (Fig. 11), or engine side housing. See Group 23 "Body and Frame" of this manual for detailed illustrations.

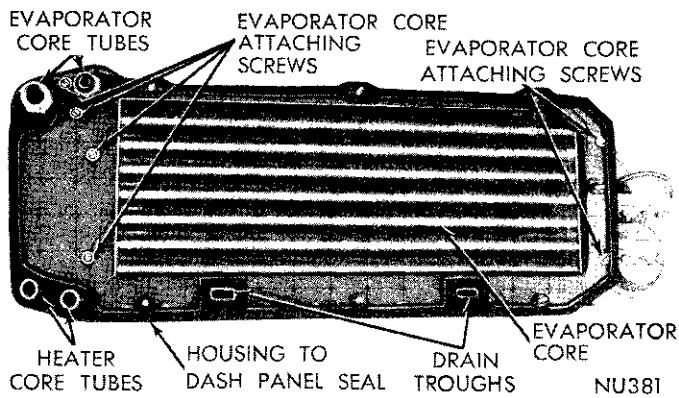
### EVAPORATOR

#### Removal

The refrigerant system must be completely discharged before opening any of the refrigerant lines.

To remove the evaporator, the entire unit housing must be removed from under the instrument panel.

(1) Disconnect negative battery cable, drain cooling system, remove air cleaner and disconnect heater



**Fig. 13—Evaporator—Back Side of Front Cover**

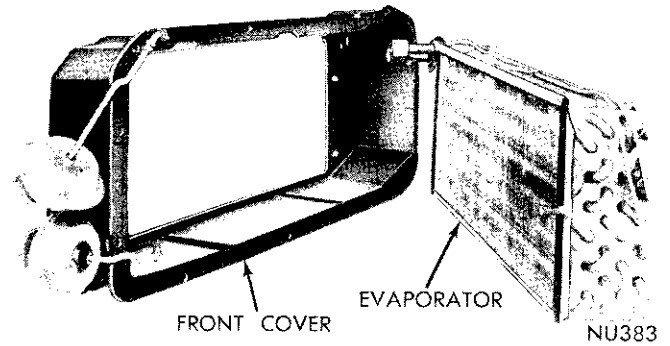
hoses. Plug both core tubes to prevent spilling coolant when unit is removed (Fig. 12).

(2) Disconnect suction line and expansion valve from evaporator tubes. Use two wrenches to loosen each of these connections. **Cap all refrigerant openings to prevent the entrance of dirt or moisture.**

(3) Remove steering column cover and remove left spot cooler duct.

(4) Remove glove box and remove center spot cooler, air distribution housing and right spot cooler duct.

(5) From glove box opening, disconnect wires at resistor block and vacuum hoses from recirculating housing actuator.



**Fig. 14—Evaporator Removed from Front Cover**

(6) Unplug antenna wire from radio and place wire out of the way.

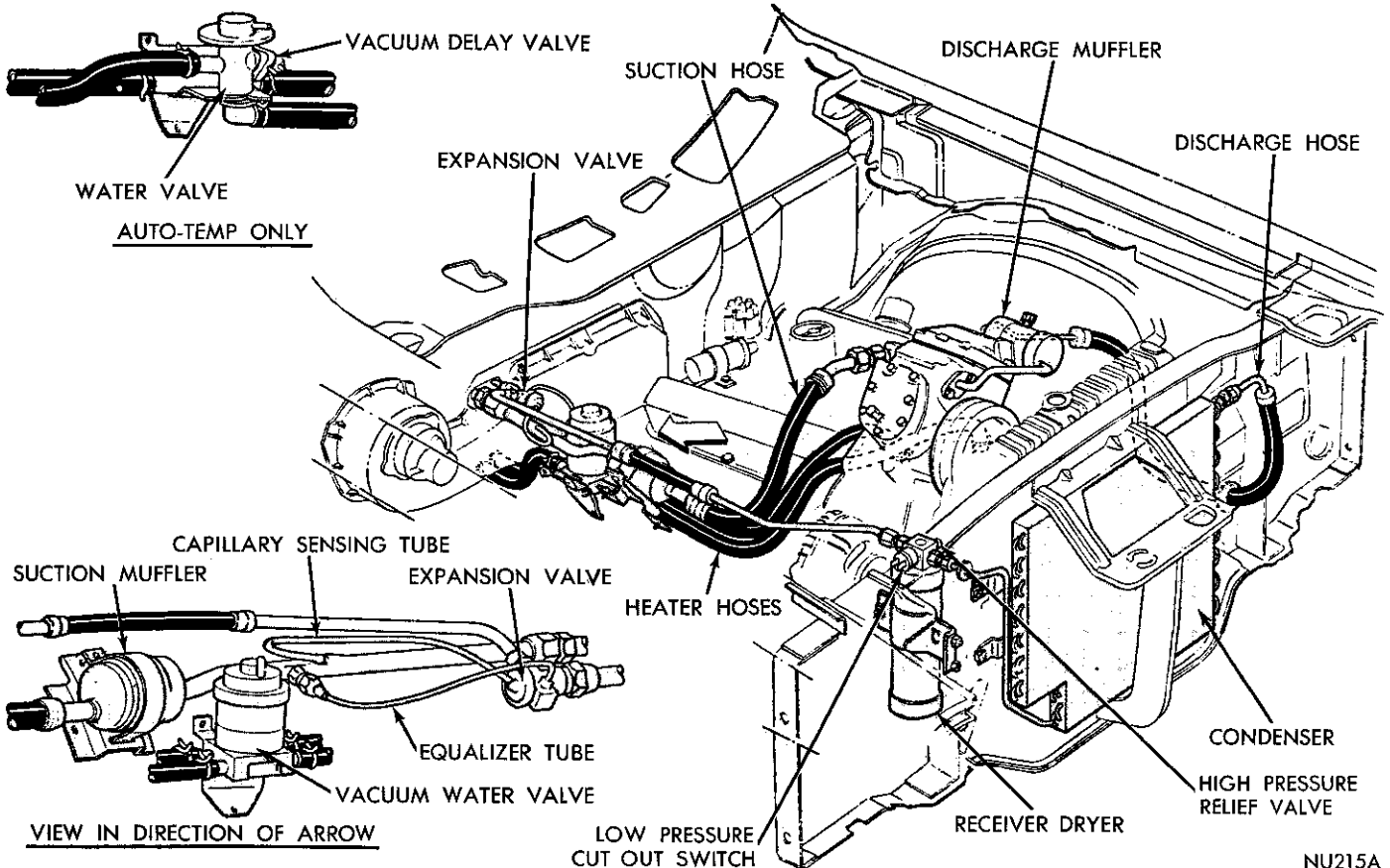
(7) From engine compartment remove seven retaining nuts surrounding engine side housing (Fig. 46).

(8) Through glove box opening remove retaining nut from housing end of support bracket and swing bracket up out of the way.

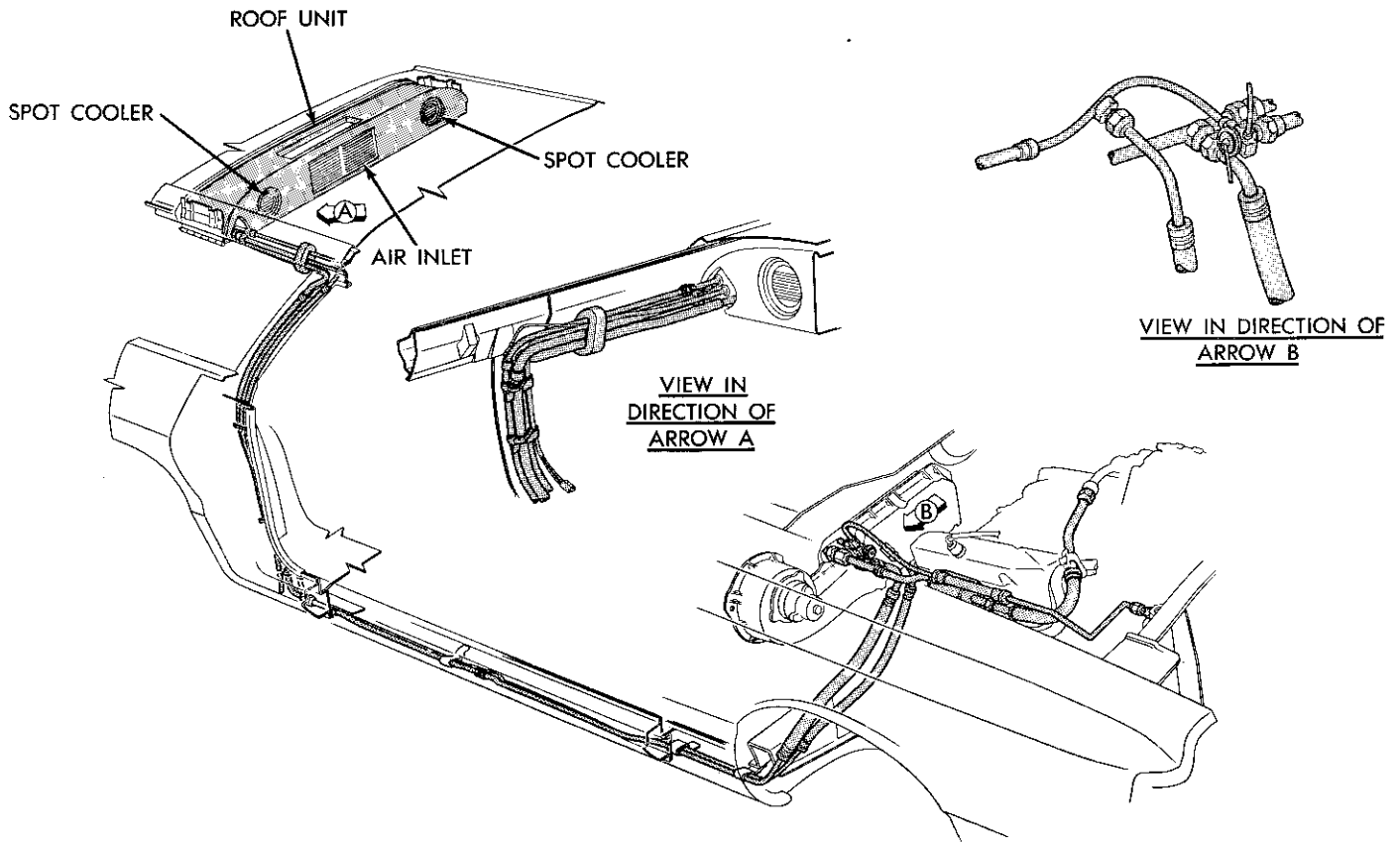
(9) Carefully roll housing out from under instrument panel.

(10) Place unit on bench, disconnect actuator rods, remove heat distribution duct, and separate front cover from evaporator housing by removing eleven screws surrounding the housings.

(11) From the tube side of the evaporator housing,



**Fig. 15—Air Conditioning and Heater Plumbing 318 Engines**



**Fig. 16—Roof Unit Air Conditioning Plumbing Station Wagon Only—Chrysler**

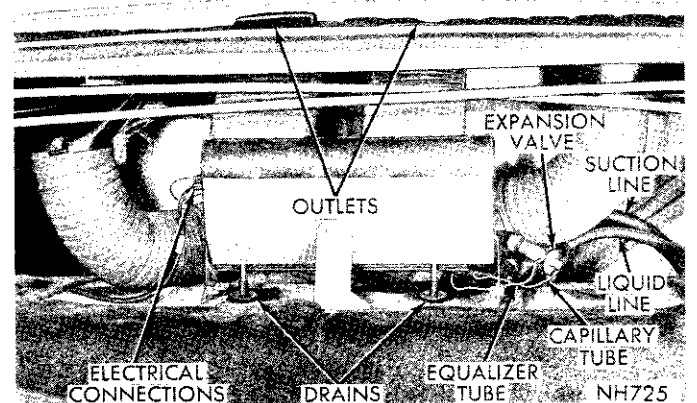
remove six screws and carefully lift out the evaporator (Figs. 13 and 14).

**Installation**

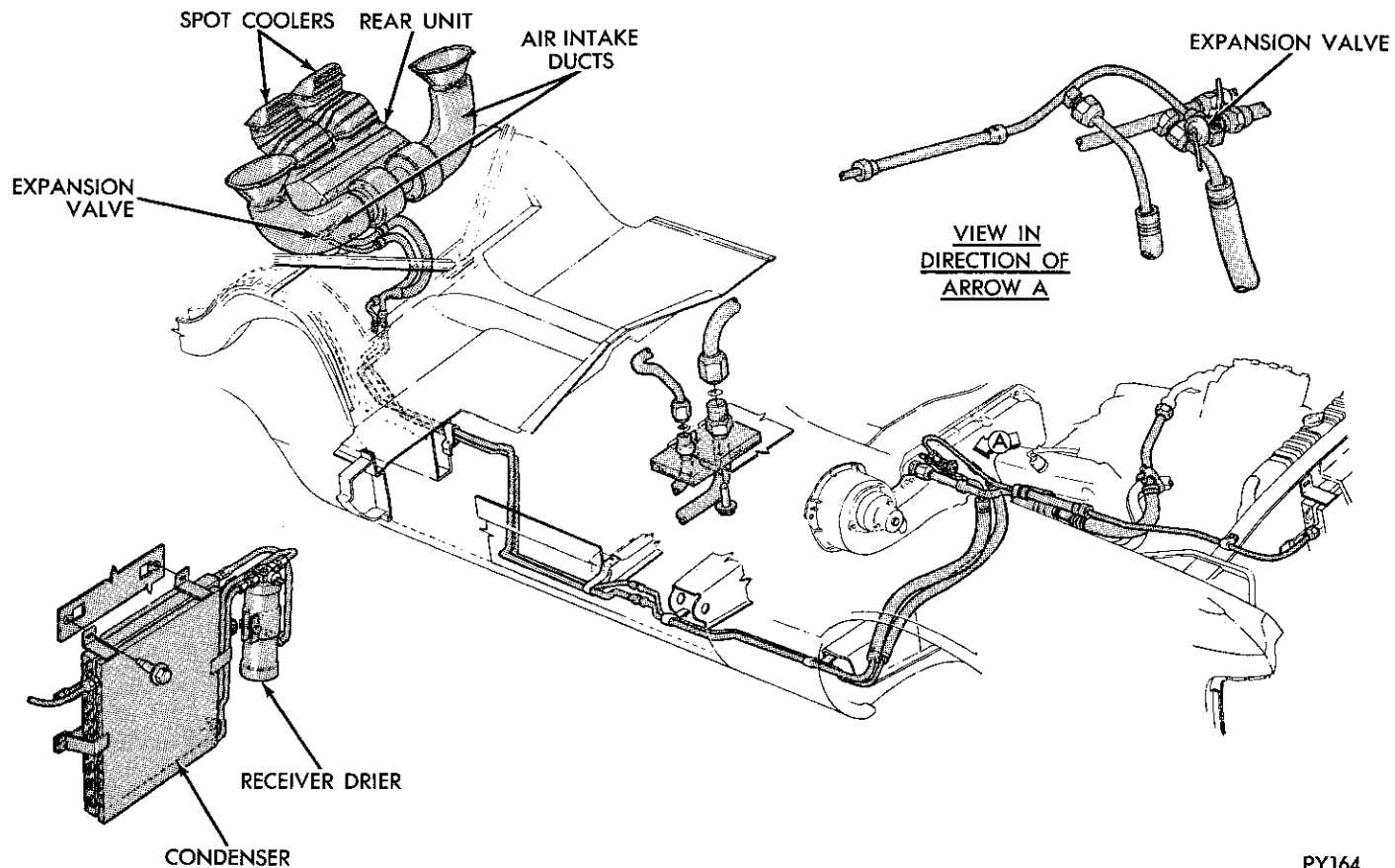
- (1) Position evaporator core in housing, align holes and install six mounting screws.
- (2) Place heater core and front cover on evaporator core and secure the two-covers with eleven screws.
- (3) Install heat distribution duct to bottom of housings.
- (4) Connect actuator rods and adjust linkage if necessary.
- (5) Position unit under instrument panel and place support bracket over existing stud on face of housing. Install retaining nut.
- (6) From engine compartment, install seven retaining nuts to studs surrounding engine side housing.
- (7) From glove box opening, connect wire to resistor block and vacuum hoses to recirculating housing actuator.
- (8) Install center air distribution housing, center spot cooler and right spot cooler duct. Plug antenna wire into radio and replace glove box.
- (10) Connect vacuum hoses to actuator on left side of housing.
- (11) Install steering column cover.
- (12) Install left spot cooler duct.

- (13) Connect suction line and expansion valve. Use two wrenches to tighten fittings (Fig. 15 and 16).
- (14) Connect heater hoses, fill cooling system and inspect for leaks.
- (15) Install air cleaner and connect battery cable.

**After the evaporator and heater assembly is installed in the vehicle, it will be necessary to sweep the system, test for leaks and charge the system with the proper amount of refrigerant. It is recommended that**



**Fig. 17—Evaporator Installed in Trunk—Imperial Only**



PY164

**Fig. 18—Rear Unit Air Conditioning Plumbing Imperial Only**

the operation of all controls be tested and an overall performance test be made after the repair or replacement of the evaporator assembly.

**REAR UNIT (Imperial) (Fig. 17 and 18)**

**Removal**

- (1) Discharge the refrigerant from the system.
- (2) Remove the rear seat, back rest and insulation blanket to assist in removal of the trunk unit components.
- (3) Release the four clamps on the flexible ducts and remove the ducts from the evaporator.
- (4) Disconnect electrical connections and drains.
- (5) Disconnect the suction and discharge lines. Cap all refrigerant lines to prevent dirt and moisture from entering the system.
- (6) Remove the mounting bracket to flange bolts (six) and remove the evaporator assembly from the luggage compartment.

**Installation**

- (1) Position the evaporator assembly in the luggage compartment and install the mounting bracket to flange bolts. The blower motor ground is connected to the left front bolt.
- (2) Install the electrical connection and drains.
- (3) Use new "O" rings with clean refrigerant oil on connections. Install the suction and discharge lines using two wrenches to prevent rotation and twisting of the lines.
- (4) Install the flexible ducts and secure the clamps.
- (5) After the evaporator assembly is installed in the vehicle, it will be necessary to sweep the system. Test for leaks, and charge with the proper amount of refrigerant. **An over-all Performance Test should be made after repair or replacement of the evaporator assembly.**
- (6) Install the insulation blanket, back rest and back seat.

**AUTO TEMP  
CHRYSLER AND IMPERIAL  
INDEX**

<p>General Information ..... 46</p> <p>Major Components ..... 46</p>	<p>Operating Controls ..... 46</p> <p>Performance Tests ..... 71</p>
--	--

	Page		Page
Push Button Control Chart .....	56	Test Connections .....	48
Service Procedures .....	54	Vacuum Circuits .....	71
Service Diagnosis .....	50	Wiring Diagram .....	63
System Test Procedure .....	55		

## GENERAL INFORMATION

The Auto-Temp System automatically controls the heating and air conditioning operation of the vehicle to maintain a selected interior temperature. In cold weather, the system provides heat. In warm weather the system provides cool dehumidified air.

The unit will heat or cool according to interior temperature, ambient temperature and control setting; in varying degrees of either heating or cooling without any action on the part of the operator other than dialing a desired temperature and setting the system on "Auto".

The basic air conditioning package is the same as that used for the standard heater-air conditioning system (Fig. 1). The controls have been changed and various sensors and components have been utilized to compose the "Auto-Temp" system.

## OPERATING CONTROLS

The Automatic Temperature Controls are located in the center of the instrument panel and consist of a thumbwheel selector and five push-button switches.

### Thumbwheel Selector

Thumbwheel selector operates similar to a home thermostat. The thumbwheel has 5 numbers, 65-70-75-80-85, to allow the operator to select a corresponding interior temperature (Fig. 3).

### Pushbutton Switches

**Off**—System will not operate (servo will be properly positioned but the blower will not operate and the fresh air door will be closed).

**Auto**—Blower will automatically remain off and the fresh air door will remain closed (if heating is required) until water temperature reaches 125°F.—temperature controlled discharge air will then come out of the heater slots (with normal defrost bleed) or the air conditioning outlets as required by the system. There are five blower speeds available on the air conditioning mode of operation and four available on the heat mode (the maximum blower speed on air conditioning is higher than the maximum blower speed on heat).

**Hi-Auto**—Same as "Auto," except the blower will operate at the higher speeds only. There are three blower speeds available on the air conditioning mode and two available on the heat mode of operation (again the maximum blower on air conditioning is

higher than the maximum blower on heat and the speeds are slightly higher in the "Hi-Auto" position). **This position is available to allow the operator to select the higher blower speeds that are required to:**

- (1) Maintain comfort during city traffic operation where air distribution may be inadequate.
- (2) Satisfy the rear seat passengers under extreme conditions.
- (3) Provide adequate smoke removal under extreme conditions.

**Def**—Blower will come on immediately, air will come out of defroster outlets (with normal heat bleed)—system will then control the same as "Auto" except the blower will operate at the two highest speeds only (the speeds being those used on the heat mode of operation). **Since the system controls in the "Def" position, it is possible to have maximum air conditioned air deposited on the windshield (and at the same time obtaining the higher blower speed that is available on the air conditioning mode of operation). However, it is not probable that the system would be operated in the "Def" position while requiring full cooling on the car interior.**

**Hi-Def**—Same as "Def" except blower will operate on high speed (used on the heat mode of operation) only and discharge air will be maximum temperature.

Both "Def" and "Hi Def" positions override a vacuum circuit to start the blower, regardless of water temperature. Therefore, if the operator returns to either the "Auto" or "Hi-Auto" position, the blower will remain on, even though the water temperature is still below 125°F. However, the blower may be turned off by depressing the "Off" button.

In all of the positions except "Off," the compressor will operate if the ambient temperature is above 32°F.

## MAJOR COMPONENTS (Fig. 2)

### In-Car Sensor

This sensor is located in a grille to left of steering column in upper left corner of instrument panel. It senses car interior temperature and automatically signals the control unit to compensate for any variation from the selected comfort setting.

### Temperature Control Dial (Thumbwheel)

This control is located above the push buttons in the control head. It allows the operator to select any

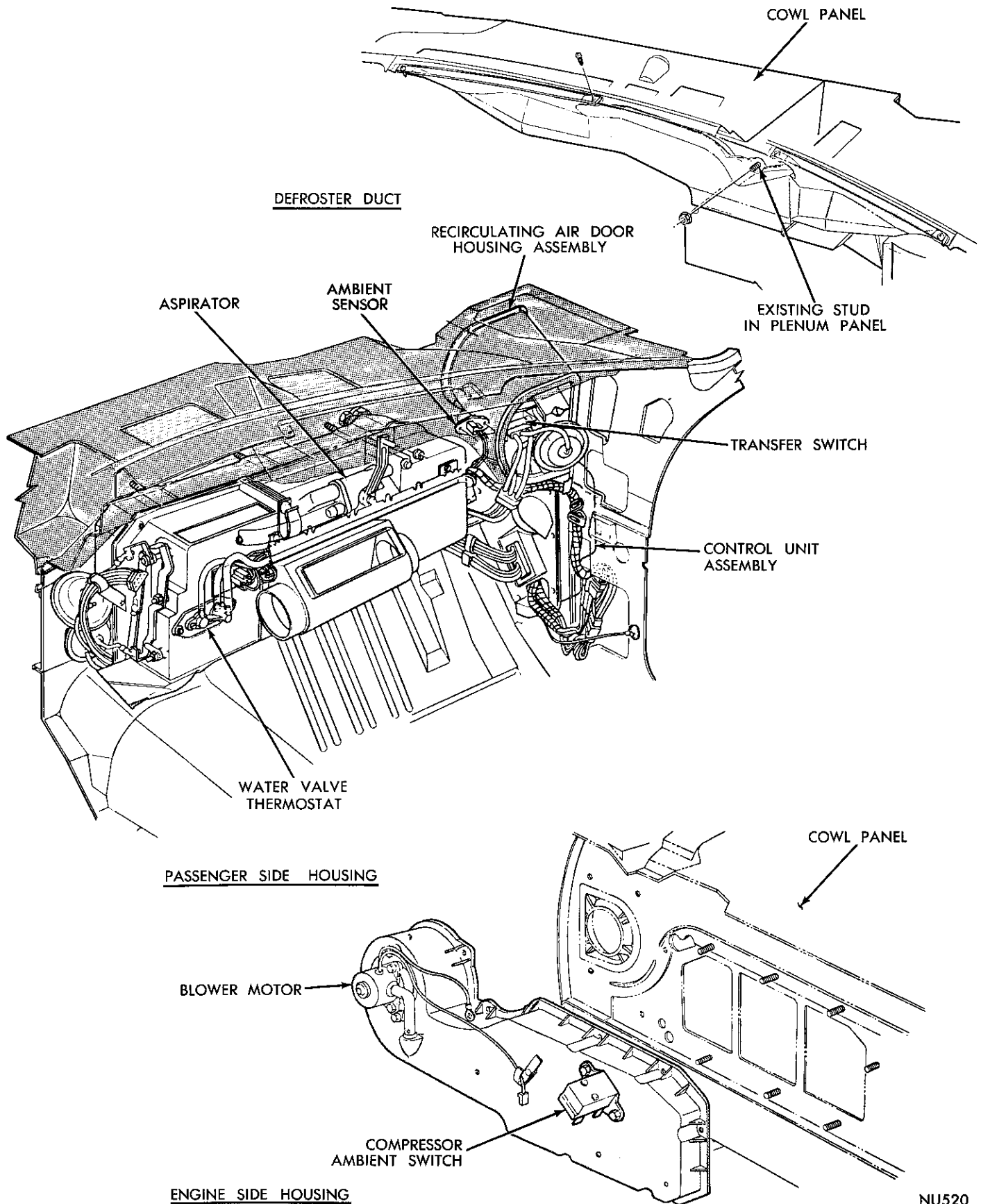


Fig. 1—Auto-Temp Housing Assemblies

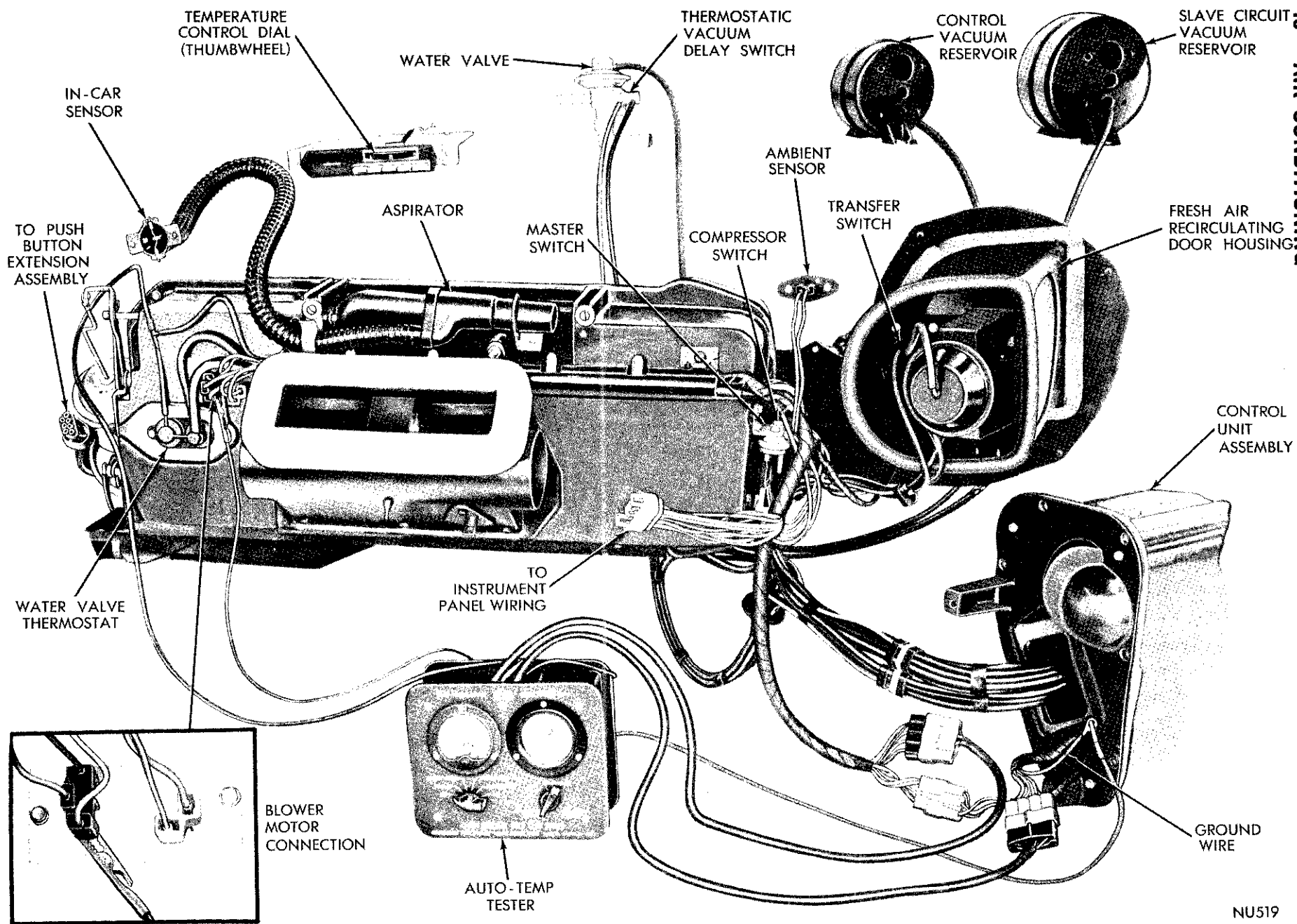
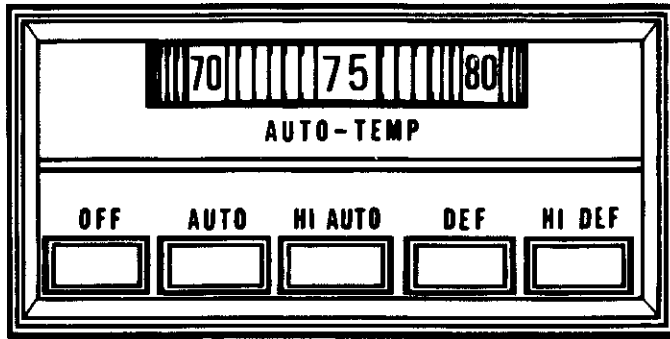


Fig. 2—Auto-Temp Components and Test Connections





NU513

**Fig. 3—Push Button Control**

interior comfort setting from 65 to 85. Movement of the thumbwheel controls a resistance potentiometer which is part of the assembly. The potentiometer will create the proper resistance to signal the control unit so that it will control at the selected comfort setting.

**Evaporator Temperature Regulator Switch (Anti-Frost Control System)**

This switch is located on the right end of the passenger side housing. It has a sensing capillary routed through the evaporator coil fins. This control allows the evaporator to maintain a minimum air temperature without freezing. The Anti-Frost control system consists of a second unit, the **evaporator temperature regulator valve (ETR)**. This valve is located at the compressor suction fitting (same place as the regulator EPR valve). It consists of an electrical solenoid which is actuated by the evaporator temperature regulator switch which senses coil fin temperature. When the solenoid is energized the valve closes and stops the flow of refrigerant to the compressor.

**Master On-Off Switch**

This switch is located on the right end of the passenger side housing and is color coded green. It is vacuum operated and turns on the blower when 8 inches of vacuum is applied.

**Compressor Switch (Vacuum)**

This switch is color coded yellow and is located on the rear cover of the air conditioning unit just to the left of the master on-off switch. It is vacuum operated and actuates the compressor clutch when 2 inches of vacuum is applied (if the ambient switch is closed).

**Water Valve Thermostat**

This thermostat is located on the face of the rear cover of the air conditioning unit. It is vacuum operated and temperature compensated and in conjunction with the water valve, controls the discharge air

temperature. The thermostat receives the same vacuum as the control unit and then sends modulated vacuum to the water valve to control the amount of engine coolant to the heater core.

**Ambient Switch**

This switch is located on the face of the engine side housing. It has a sensing capillary protruding through the bottom of the housing in front of the blower inlet. The compressor switch completes the electrical circuit to the clutch if the ambient (outside) temperature is above 32°F. Due to its location, the switch will become heated periodically during the winter by brief shut downs of the Auto-Temp or the engine. On re-starts, the compressor will operate briefly and allow the seals of the compressor to be lubricated.

**Vacuum Transfer Switch**

This switch is located in the fresh/recirculating air door housing. The switch holds the fresh/recirculating air door in one of three positions: OFF, 20% Fresh Air and 100% Fresh Air. The three positions are accomplished by the use of the regulator vacuum actuator, a spring and the transfer switch.

**Thermostatic Vacuum Delay Switch**

This switch is located on the water valve in the engine compartment. It is an integral part of the water valve and is controlled by a wax pellet that is sensitive to water temperature. The switch delays the start of the blower, by not allowing the vacuum circuit to the blower master switch to be completed on AUTO or HI-AUTO position (heat mode) until the engine water temperature reaches 125°F. At that point the switch opens and allows vacuum to the master switch completing the electrical circuit to the blower motor. Vacuum to vacuum transfer switch allows switch to position door in 100% fresh air position.

**Ambient Sensor**

This sensor is located in the dash panel behind the glove box. The ambient sensor senses the outside temperature. It signals the control unit to make adjustments to the system that are required to maintain a constant interior comfort level regardless of outside temperature changes.

**Control Unit Assembly**

This unit is located in place of the right side cowl vent assembly. It is the control unit of the system and consists of a power servo, amplifier and transducer. If the unit is found defective, it is to be replaced as an assembly and no attempt shall be made to service it internally.

**SERVICE DIAGNOSIS**

Condition	Possible Cause	Correction
<b>SYSTEM OPERATES ONLY ON MAXIMUM COOLING AND HI-BLOWER.</b>	<ul style="list-style-type: none"> <li>(a) Control vacuum leak external to control unit assembly.</li> <li>(b) Internal control unit assembly leak.</li> <li>(c) A short circuit in the ambient or in-car sensor.</li> <li>(d) An open circuit in the temperature control dial potentiometer.</li> <li>(e) Defective control unit assembly.</li> <li>(f) No vacuum input to control unit (crossed hoses at control vacuum reservoir or at control unit, pinched hose).</li> <li>(g) Vacuum leak in water valve thermostat.</li> </ul>	<ul style="list-style-type: none"> <li>(a) Inspect vacuum connections at water valve thermostat, control unit assembly, and engine components.</li> <li>(b) Test control unit assembly, replace if leaking.</li> <li>(c) Inspect wiring, repair short or replace sensor.</li> <li>(d) Test wiring, replace potentiometer if necessary.</li> <li>(e) Test control unit assembly, replace if necessary.</li> <li>(f) Check vacuum lines.</li> <li>(g) Test thermostat.</li> </ul>
<b>SYSTEM OPERATES ON AIR CONDITIONING MODE AT ALL TIMES WITH CONTROLLED AIR TEMPERATURE.</b>	<ul style="list-style-type: none"> <li>(a) Damper linkage binding, from improper adjustment.</li> <li>(b) Vacuum not supplied to rod side of mode actuator.</li> </ul>	<ul style="list-style-type: none"> <li>(a) Re-adjust linkage.</li> <li>(b) Check vacuum line connection (plugged or disconnected at actuator fitting. Check for pinched vacuum line).</li> </ul>
<b>SYSTEM OPERATES ONLY ON MAXIMUM HEATING AND M3.</b>	<ul style="list-style-type: none"> <li>(a) An open circuit in the in-car sensor.</li> <li>(b) A short circuit in the temperature control dial potentiometer.</li> <li>(c) Defective control unit assembly.</li> <li>(d) An open circuit in ambient sensor.</li> </ul>	<ul style="list-style-type: none"> <li>(a) Test wiring, repair or replace sensor.</li> <li>(b) Test wiring, repair or replace potentiometer.</li> <li>(c) Test control unit assembly, replace if necessary.</li> <li>(d) Test wiring, repair or replace sensor.</li> </ul>
<b>SYSTEM OPERATES ON HEAT MODE AT ALL TIMES</b>	<ul style="list-style-type: none"> <li>(a) An open circuit in the ambient sensor.</li> <li>(b) Damper linkage binding from misadjustment.</li> <li>(c) Vacuum not supplied to pot side of mode actuator.</li> </ul>	<ul style="list-style-type: none"> <li>(a) Test wiring, repair or replace sensor.</li> <li>(b) Readjust properly.</li> <li>(c) Inspect vacuum line connection (plugged or not connected at actuator fitting. Check for pinched vacuum line).</li> </ul>
<b>SYSTEM PUTS OUT ONLY HOT AIR IN ALL MODES AT ALL TIMES</b>	<ul style="list-style-type: none"> <li>(a) Defective water valve thermostat.</li> <li>(b) Defective water valve (stuck open).</li> <li>(c) Water valve thermostat not sensing representative air temperature.</li> </ul>	<ul style="list-style-type: none"> <li>(a) Replace if necessary.</li> <li>(b) Replace if necessary.</li> <li>(c) Check for abnormal cold air in area of the thermostat (missing seals inside evaporator package or partially plugged heater core). Repair or replace package.</li> </ul>
<b>SYSTEM PUTS OUT ONLY COLD AIR IN ALL MODES AT ALL TIMES</b>	<ul style="list-style-type: none"> <li>(a) Defective water valve thermostat.</li> <li>(b) Defective water valve (stuck closed).</li> <li>(c) Kinked water hose.</li> <li>(d) No vacuum to water valve (pinched or disconnected vacuum line to water valve or to thermostat).</li> </ul>	<ul style="list-style-type: none"> <li>(a) Replace if necessary.</li> <li>(b) Replace if necessary.</li> <li>(c) Inspect hoses.</li> <li>(d) Inspect lines.</li> </ul>
<b>BLOWER AND COMPRESSOR WILL NOT OPERATE, AND SYSTEM WILL NOT GO INTO SELECTED MODE</b>	<ul style="list-style-type: none"> <li>(a) A failed (open) circuit.</li> <li>(b) A vacuum leak at engine fitting source or slave circuit tank in engine compartment.</li> <li>(c) A loose connection between harness and push button switch.</li> <li>(d) A defective (leaking) vacuum harness connector at push button switch.</li> <li>(e) A defective (leaking) push button switch.</li> </ul>	<ul style="list-style-type: none"> <li>(a) Replace if necessary.</li> <li>(b) Check vacuum connections.</li> <li>(c) Connect properly.</li> <li>(d) Replace harness.</li> <li>(e) Replace switch.</li> </ul>

Condition	Possible Cause	Correction	
<b>BLOWER WILL NOT OPERATE ON ANY MODE.</b>	(f) Vacuum hose leak in slave circuit.	(f) Inspect all connections, repair if possible, replace if necessary.	
	(g) Crossed vacuum lines at slave system vacuum reservoir.	(g) Inspect lines.	
	(h) Pinched vacuum line in slave circuit.	(h) Inspect lines.	
	(a) Blower motor wiring disconnected.	(a) Connect properly.	
	(b) Defective blower motor.	(b) Check by connecting directly to battery. Replace if necessary.	
	(c) Vacuum operated master on-off switch, defective.	(c) Test and replace if necessary.	
	(d) A vacuum leak in slave circuit.	(d) Inspect for leaks and correct.	
<b>COMPRESSOR WILL NOT OPERATE AT ANY TIME.</b>	(e) Resistor block burned out.	(e) Replace.	
	(f) Pinched vacuum line to master switch.	(f) Inspect lines.	
	(g) Blower motor not grounded.	(g) Ground properly.	
	(a) Clutch wire disconnected.	(a) Connect.	
	(b) Vacuum operated compressor switch, defective.	(b) Test and replace if necessary.	
	(c) Compressor ambient switch, defective.	(c) Test and replace if necessary.	
	(d) Ambient is below 32°F.	(d) Instruct owner that compressor operates only at ambients above 32°F.	
<b>AIR CONDITIONING AND HEAT MODES REVERSED (HOT AIR FROM CONDITIONING OUTLETS AND COLD AIR FROM HEAT OUTLETS).</b>	(e) Pinched vacuum line to compressor switch.	(e) Inspect lines.	
	(f) Low pressure cut-out switch defective.	(f) Test and replace.	
	(g) System pressure below low pressure cut-out switch limit.	(g) Test system for leaks and repair.	
	(a) Air conditioning and heat mode actuator vacuum hoses reversed.	(a) Route properly (white to pot side, red to shaft side).	
	<b>AIR COMING OUT OF AIR CONDITIONING OUTLETS WHEN SYSTEM IS IN THE DEFROST OR HI-DEFROST POSITION.</b>	(a) Vacuum hoses to pot side of mode actuator and pot side of defrost actuator reversed.	(a) Route properly.
		(b) Air conditioning and heat and heat and defroster mode actuator vacuum hoses interchanged and reversed on actuators.	(b) Route properly.
	<b>MOST OF THE AIR COMING OUT OF DEFROSTERS WHEN SYSTEM SHOULD BE ON THE HEAT MODE.</b>	(a) Vacuum hoses to shaft side of mode actuator and pot side of defrost actuator reversed.	(a) Route properly. (Red to shaft side, white to pot side).
(b) Air conditioning door binding on air distribution duct.		(b) Reinstall properly.	
<b>AIR COMES OUT OF THE DEFROSTERS WHEN THE SYSTEM SHOULD BE IN HEAT MODE, AND AIR COMES OUT OF HEATER OUTLETS WHEN SYSTEM SHOULD BE IN AIR CONDITIONING.</b>	(a) All vacuum lines to mode and defrost actuators completely crossed.	(a) Route properly.	
	(b) Linkage misadjustment.	(b) Readjust.	
<b>AIR COMES OUT OF ALL OUTLETS WHEN THE SYSTEM SHOULD BE IN DEFROST OR AIR CONDITIONING. AIR COMES OUT THE AIR CONDITIONING OUTLETS WHEN THE SYSTEM SHOULD BE IN HEAT MODE.</b>	(a) All vacuum lines to mode and defrost actuators completely crossed.	(a) Route properly.	
	(b) Linkage misadjustment.	(b) Readjust.	

Condition	Possible Cause	Correction
<b>SYSTEM WILL NOT CHANGE MODE IN AUTO OR HI-AUTO (EVEN WITH TESTER OPERATING CONTROL UNIT)</b>	(a) Doors binding or linkage bent or mis-adjusted.	(a) Repair or adjust linkage.
<b>AIR COMING OUT OF DEFROSTER WHEN SYSTEM SHOULD BE IN THE AIR CONDITIONING MODE.</b>	(a) Air conditioning/heat and heat/defroster mode actuator hoses interchanged and reversed on actuators. (b) Defrost button may be depressed.	(a) Route properly. (b) Instruct owner on proper operation of unit.
<b>INSUFFICIENT AIR-FLOW OUT OF UPPER (AIR CONDITIONING) OUTLETS WHEN SYSTEM IS CALLING FOR MAXIMUM COOLING AND HI-BLOWER.</b>	(a) Air hoses disconnected from air conditioning outlets or distribution duct. (b) Failing blower motor.	(a) Connect properly. (b) Test by connecting directly to battery.
<b>BLOWER SPEEDS ALWAYS TOO GREAT ON AUTO.</b>	(a) Resistor block, faulty (resistors shorted).	(a) Repair or replace.
<b>BLOWER SPEEDS ALWAYS TOO GREAT ON HI-AUTO.</b>	(a) Lower speeds not provided for Hi-Auto.	(a) Instruct owner on operation of unit.
<b>SYSTEM BLOWS COLD AIR ON FEET AT THE START DURING COLD WEATHER OPERATION.</b>	(a) Thermostatic vacuum delay switch in water valve, faulty. (b) Blower master switch inoperative in closed position. (c) Vacuum bleed plugged. (d) Check valve #2 failed open or reversed.	(a) Test and replace if necessary. (b) Test and replace if necessary. (c) Inspect. (d) Check connections, test and replace if necessary.
<b>INSUFFICIENT HEAT WHEN MAXIMUM HEATING IS REQUIRED.</b>	(a) Water valve thermostat out of calibration or faulty. (b) A vacuum leak at water valve or thermostat connections. (c) Water valve, faulty. (d) Heater core, faulty (plugged). (e) Vacuum line from control unit to water valve thermostat or from thermostat to water valve pinched.	(a) Check calibration, recalibrate or replace. (b) Check visually, repair. (c) Replace. (d) Replace. (e) Inspect lines.
<b>ERRATIC TEMPERATURE CONTROL.</b>	(a) Heater hoses reversed at core inlet and outlet tubes. (b) Air in heater core. (c) Radiator water level low. (d) Loose vacuum or electrical connection at control unit assembly. (e) Faulty water valve (sticking). (f) Water valve thermostat faulty.	(a) Route properly. (b) Press Hi-Defrost to open water valve fully and run engine at approximately 1500 rpm for about three minutes. (c) Fill as required. (d) Inspect connections. (e) Check and replace if necessary. (f) Check and replace if necessary.
<b>INSUFFICIENT COOLING WHEN MAXIMUM COOLING IS REQUIRED.</b>	(a) ETR valve stuck closed. (b) Refrigeration system low on refrigerant. (c) ETR switch cut-in setting too high. (d) Expansion valve. (e) Clutch not running (pinched vacuum line to compressor switch, wires not	(a) Check by energizing solenoid directly from battery. (b) Test for leaks, repair, and add charge according to procedure in Air Conditioning Service Manual. (c) Test according to procedures in Standard Air Conditioning Service Manual. (d) Test according to procedures in Standard Air Conditioning Service Manual. (e) Inspect vacuum lines and electrical connections, check for high resist-

Condition	Possible Cause	Correction
	connected or high resistance compressor switch).	ance by replacing switch with a jumper wire, replace switch if necessary.
	(f) Fresh air doors stuck in 100% fresh air position (broken return spring or defective vacuum transfer switch).	(f) Inspect spring, test vacuum transfer switch, replace if necessary.
<b>DISCHARGE AIR TOO COLD AT TIMES.</b>	(a) ETR valve or switch leads disconnected.	(a) Connect.
	(b) ETR valve failed (open).	(b) Check by energizing solenoid directly from battery, replace if necessary.
	(c) ETR switch failed (capillary broken).	(c) Replace.
	(d) ETR switch capillary not properly installed.	(d) Install properly.
<b>AFTER APPROXIMATELY ONE HOUR OF SUSTAINED DRIVING AIR-FLOW DROPS OFF TO PRACTICALLY NONE, WHILE BLOWER CAN BE HEARD OPERATING AT A HIGH SPEED.</b>	(a) Evaporator coil freeze-up, same causes as in "Discharge Air Too Cold At Times."	(a) Same as in "Discharge Air Too Cold At Times".
	(b) ETR switch setting too low.	(b) Check out according to Auto-Temp component test procedures.
<b>AIR COMES OUT OF AIR CONDITIONING OUTLETS OR HEAT OUTLETS WHILE DRIVING IN THE "OFF" POSITION.</b>	(a) Fresh/Recirculating door in Fresh Air position (vacuum hoses on Fresh Air door actuator reversed).	(a) Route properly.
	(b) Blower master switch (failed in closed position).	(b) Test and replace if necessary.
	(c) Fresh air door not sealing properly.	(c) Check for binding door or damaged seals. Repair.
	(d) Check valve #2 reversed or failed closed.	(d) Check connections, test and replace if necessary.
<b>OBJECTIONABLE ODORS BEING DISCHARGED THROUGH THE AIR CONDITIONING OR HEAT OUTLETS.</b>	(a) Fresh/Recirculating door in recirculating air position (vacuum hoses on Fresh Air door actuator reversed).	(a) Route properly.
<b>SYSTEM QUITS ON ACCELERATION.</b>	(a) Slave vacuum-reservoir check valve leaking.	(a) Test and replace if necessary.
	(b) A vacuum leak in slave system.	(b) Inspect all connections, repair if possible, replace if necessary.
	(c) Check valve #1 reversed or failed open.	(c) Check connections, test and replace if necessary.
<b>SYSTEM WILL NOT GO TO MAXIMUM HEAT ON HI-DEFROST.</b>	(a) Defrost override circuit in amplifier of control unit assembly defective.	(a) Check unit for proper performance.
	(b) Hi-Defrost feed from push button switch to amplifier not connected at switch.	(b) Connect.
	(c) Push button actuated Hi-Defrost feed switch in control head, faulty.	(c) Replace push button switch.
<b>SYSTEM SHUTS OFF WHEN HI-DEFROST BUTTON IS PUSHED AND GOES TO HI-DEFROST WHEN THE OFF BUTTON IS PUSHED.</b>	(a) Push button switch reversed (push button extensions incorrectly installed).	(a) Visually inspect switch (vacuum ports and electrical terminals are located left and right side of switch respectively, as viewed by passenger if switch is properly installed). Remove and reassemble if necessary.
<b>SYSTEM DOES NOT ACHIEVE A COMFORTABLE CONDITION—SYSTEM LEVELED OUT</b>	(a) Control dial potentiometer out of calibration.	(a) Test and recalibrate if possible, replace if necessary.
	(b) Control unit assembly out of calibration.	(b) Test and replace if necessary.
	(c) Air conditioning outlets not directed properly.	(c) Instruct owner on positioning of outlets and/or on moving control dial slightly to attain his comfort level.

Condition	Possible Cause	Correction
<b>SYSTEM DOES NOT ACHIEVE A COMFORTABLE CONDITION—ERRATIC CHANGES OF TEMPERATURE AND POSSIBLY BLOWER SPEED</b>	(d) Aspirator not operating properly (pinched or disconnected tube).	(d) Test aspirator and tube. Repair or replace if necessary.
	(a) Loose electrical connection at sensors or at control unit.	(a) Inspect connections.
	(b) Loose electrical connection or other fault in control unit.	(b) Test control unit, replace if necessary.
<b>SYSTEM DOES NOT ACHIEVE A COMFORTABLE CONDITION—CYCLING OF TEMPERATURE AND POSSIBLY BLOWER SPEED</b>	(a) Defective control unit (excessive play in power servo.)	(a) The control vacuum at the calibration point on decreasing vacuum should be within 1 inch of the reading on increasing vacuum.
	(b) Vacuum leak in control unit, in the water valve thermostat, or at the connections to them.	(b) Check connections, check control unit and thermostat for leaks. Replace if necessary.
	(c) Aspirator not operating properly (pinched or disconnected tube).	(c) Test aspirator and tube. Repair or replace if necessary.
	(d) Water valve sticking.	(d) Test and replace if necessary.
	(e) Water valve thermostat out of calibration.	(e) Test and replace if necessary.
<b>SYSTEM DOES NOT ACHIEVE A COMFORTABLE CONDITION—TEMPERATURE SLOWLY DRIFTS UP AND DOWN</b>	(a) Aspirator not operating properly (pinched or disconnected tube).	(a) Test aspirator and tube. Repair or replace if necessary.
	(b) Frayed or bare sections in sensor leads.	(b) Inspect sensor leads. Repair or replace.
<b>BLOWER DOES NOT SHUT OFF WHEN "OFF" BUTTON IS PUSHED</b>	(a) Check valve #2 failed closed or installed backwards.	(a) Check routing and replace if necessary.
	(b) Defective pushbutton switch.	(b) Check switch according to push button control charts check routing.
<b>BLOWER DOES NOT COME ON IN "DEFROST" OR "HI-DEFROST" WHEN THE ENGINE IS COLD</b>	(a) Check valve #1 failed closed or installed backwards.	(a) Test and replace if necessary.
<b>BLOWER SPEED CHANGES WITH CHANGES IN CAR VOLTAGE (CAR IS ACCELERATED OR ACCESSORIES ARE TURNED ON OR OFF)</b>	(a) Defective control unit.	(a) Test control unit and replace if necessary.

## AUTO-TEMP COMPONENTS

### SERVICE PROCEDURES

Satisfactory performance of the Auto-temp system is dependent upon proper operation and adjustment of all operating controls, as well as proper functioning of all system components. The inspection, tests and adjustments should be used to locate the cause of a malfunction. The inspections and tests in this manual have been arranged in a logical sequence that has proved to be the surest and shortest route to accurate diagnosis. It is recommended that they be followed and performed in the order in which they are presented.

#### Test Connections (Auto-Temp Tester C-4064)

With the use of the Auto-Temp Tester (C-4064) (Fig. 2), a thorough operational check can be performed on the system, and some of the components. Connect the tester according to procedure:

- (1) Remove right cowl trim panel.
- (2) Disconnect electrical harness eight terminal connector and connect tester in series with system harness and control unit harness (Fig. 2).
- (3) Remove left spot cooler duct.

(4) Raise blower motor three wire connector slightly off spade terminals, enough to attach alligator clip (Fig. 2). Black wire from tester. (Tan lead on blower motor resistor).

(5) Attach tester white wire to a good body ground.

(6) Tee in vacuum hose at the water valve thermostat. (Solid black hose).

**Before performing any tests, the control potentiometer on the instrument panel must be set at 75 and must remain at this setting throughout all tests.**

### Control Unit Calibration

With engine idle set at 1000 RPM and the voltmeter in the off position, depress the "Auto" button and slowly rotate control dial, on tester, from minimum vacuum to "Calibrate". At this point the vacuum gauge should read 4 to 6 inches vacuum. Tap gauge and record this reading. Continue to increase vacuum to "Maximum" then slowly rotate control dial back to "Calibrate". Tap gauge. Reading must be within 1 inch Hg of the recorded reading, indicating the control unit is calibrated.

If the gauge readings are not within the given range, the control unit is out of calibration and must be replaced.

### Sensor Tests

With engine running at idle RPM, rotate voltmeter dial from off to the "ambient sensor" position. Observe the voltmeter, if the indicator is in the red area to the left, the sensor is "shorted", if the indicator is in the red area to the right, the sensor is "open", in either case the sensor is faulty and must be replaced. The above procedure applies to the temperature control (set at 75), and in-car sensor.

**CAUTION: Do not allow the voltmeter dial to remain in any of the sensor positions for more than 30 seconds, as voltage is being applied to the sensors and they may be damaged.**

With the above instrumentation, a thorough operational check can be performed on the system, and some of the components. Refer to the push button control chart while performing the following steps:

## SYSTEM TEST PROCEDURE

Start engine with system in the Off position and thermometer in right center outlet. Set control Vacuum Dial to obtain "0" vacuum on gauge. Set voltmeter on "Voltage". Adjust engine rpm to 1000. Observe the following:

- (1) Vacuum should be zero.
- (2) No reading on voltmeter.

Push the Hi-Auto Button. **Observe the following:**

- (1) Vacuum should remain at zero.
- (2) Compressor should be running and system should be in the air conditioning mode with fresh air

door open to 20 (Above 32° Ambient).

(3) Blower should be running.

(4) Blower speed should be high if vacuum is less than 2.5 inches. Voltmeter should read approximately the same as supply voltage at the voltage regulator.

(5) Discharge air should be coming out of air conditioning (upper) outlets and should be dropping towards 40°F.

If all the mentioned steps occurred as stated, the system is operating properly in this position.

### Auto

Proceed as follows:

Push Auto button and slowly rotate control Vacuum Dial so vacuum at gauge goes from minimum to maximum in such a manner that the following may be observed taking place in the order shown:

- (1) Blower speed drops one step.
- (2) Fresh air door goes from 20% to 100% Fresh/Air at above 3.5 inches vacuum, no change in discharge air temperature.
- (3) Blower speed decreases a second step, a slight increase in discharge air temperature (approximately 10°F.).
- (4) Blower speed decreases a third step, an additional rise in discharge air temperature.
- (5) Blower speed decreases a fourth step, an additional rise in air temperature.
- (6) System goes from A/C mode to Heat mode at about 8.0 inches vacuum. Discharge air temperature is within 85°F.  $\pm$  10° before and after the mode switch.
- (7) After the switch to Heat mode, the blower speed increases one step, an additional rise in discharge air temperature.
- (8) Blower speed increases a second step, an additional rise in discharge air temperature.
- (9) Blower speed increases a third step, discharge air temperature is at its maximum (approximately 140°F.), and vacuum is about 12 inches.
- (10) Continue to move control such that vacuum increases to full source vacuum, note that there is no further change in blower speed and little or no increase in discharge air temperature.

### Hi-Auto

Adjust Control Vacuum Dial so vacuum is about 8.0 inches.

Push Hi-Auto button and observe the following:

An increase in air velocity. Note voltage increase on voltmeter, there was no change of vacuum and little or no temperature change.

### Defrost

Return to Auto position leaving vacuum at about 8 inches on either air conditioning or heat and proceed as follows:

Push defrost button and observe the following:

- (1) Vacuum remained the same.
- (2) Majority of air is coming out of defroster outlets and there is bleed air coming out of heater slots. No air should be coming out of A/C outlets.
- (3) The air temperature should have remained essentially the same as in Auto.
- (4) Blower speed increases.

**Hi-Defrost**

Push Hi-Defrost button and observe the following:

- (1) Vacuum is increasing to full source vacuum.
- (2) The air temperature at defroster outlets is rising to maximum heat.
- (3) Blower speed increases.
- (4) Control dial on tester is no longer effective.

**PUSH BUTTON CONTROL CHART**

Push Button Position	Control Vacuum	Fresh Air Door Position	A/C Door Position	Heat Door Position	Defrost Door Position	Blower Motor Speed
<b>OFF</b>	Below 8 inches Hg. Above 8 inches Hg.	0% F/A 0% F/A	Open Closed	Closed Open	Closed Bleed	Off Off
<b>AUTO</b> Slowly rotate vacuum control knob from minimum to maximum	Minimum (0" Hg.)	20%	Open	Closed	Closed	Hi
	↓	20%	Open	Closed	Closed	Hi to M3
	3.5	100%	Open	Closed	Closed	M3
	↓	100%	Open	Closed	Closed	M3 to M2
	↓	100%	Open	Closed	Closed	M2 to M1
	7.5 to 9.0	100%	Open	Closed	Closed	M1 to Lo
	↓	100%	Closed	Open	Bleed	Lo
	12.0	100%	Closed	Open	Bleed	Lo to M1
	↓	100%	Closed	Open	Bleed	M1 to M2
	↓	100%	Closed	Open	Bleed	M2 to M3
Slowly rotate vacuum control knob from maximum to minimum	12.0	100%	Closed	Open	Bleed	M3
	↓	100%	Open	Closed	Closed	Lo
	6.5 to 7.5	100%	Open	Closed	Closed	Lo
	↓	20%	Open	Closed	Closed	M3
	2.5	20%	Open	Closed	Closed	M3
<b>HI-AUTO</b> Slowly rotate vacuum control knob from minimum to maximum	0	20%	Open	Closed	Closed	Hi
	↓	20%	Open	Closed	Closed	Hi
	Minimum (0" Hg.)	20%	Open	Closed	Closed	Hi
	↓	20%	Open	Closed	Closed	Hi to M3
	3.5	100%	Open	Closed	Closed	M3
	↓	100%	Open	Closed	Closed	M3 to M2
	7.5 to 9.0	100%	Open	Closed	Closed	M3 to M2
	↓	100%	Closed	Open	Bleed	M2
	12.0	100%	Closed	Open	Bleed	M2 to M3
	↓	100%	Closed	Open	Bleed	M2 to M3
Slowly rotate vacuum control knob from maximum to minimum	12.0	100%	Closed	Open	Bleed	M3
	↓	100%	Open	Closed	Closed	M3
	6.5 to 7.5	100%	Open	Closed	Closed	M2
	↓	20%	Open	Closed	Closed	M3
	2.5	20%	Open	Closed	Closed	M3
0	20%	Open	Closed	Closed	Hi	



**PUSH BUTTON CONTROL CHART  
(Continued)**

Push Button Position	Control Vacuum	Fresh Air Door Position	A/C Door Position	Heat Door Position	Defrost Door Position	Blower Motor Speed	
<b>DEFROST</b> Slowly rotate vacuum control knob from maximum to minimum	Minimum (0" Hg.)	20%	Closed	Bleed	Open	Hi	
	↓	20%	Closed	Bleed	Open	Hi to M3	
	3.5	100%	Closed	Bleed	Open	M3	
	↓	100%	Closed	Bleed	Open	M3 to M2	
	7.5 to 9.0	100%	Closed	Bleed	Open	M2	
	↓	12.0	100%	Closed	Bleed	Open	M2 to M3
Slowly rotate vacuum control knob from minimum to maximum	↓	100%	Closed	Bleed	Open	M3	
	12.0	↓	20%	Closed	Bleed	Open	M2
	2.5	↓	20%	Closed	Bleed	Open	M1
	0						
<b>HI-DEFROST</b> (Temp. control dial has no effect)	12.0" or Above	100%	Closed	Bleed	Open	M3	

**Blower Motor Speeds**  
 Hi—  
 M3—One speed down from Hi  
 M2—One speed down from M3  
 M1—One speed down from M2  
 Lo—One speed down from M1

**CONTROL UNIT ASSEMBLY (Fig. 4)**

If the control unit assembly is found defective, it is to be replaced as an assembly, and no attempt shall be made to service it.

It should be noted here that other component failures in the system can create the same symptoms as a defective control unit assembly. Therefore, a thorough check of other components should be made as directed in the service diagnosis charts before the control unit is replaced.

**Water Valve Thermostat**

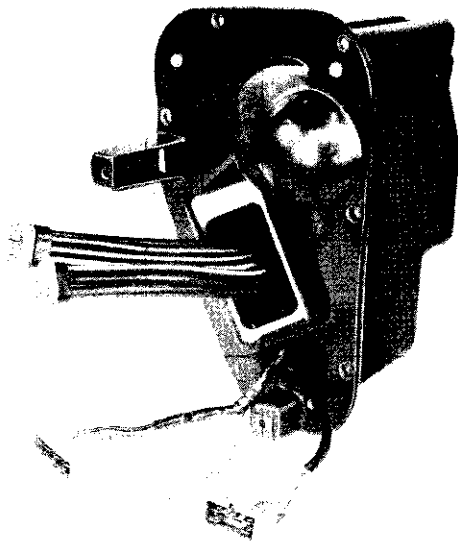
The thermostat is vacuum-operated and temper-

ature-compensated, and in conjunction with the water valve, controls the discharge air temperature. It received the same vacuum as the power servo and then sends a modulated vacuum to the water valve to maintain a constant duct discharge temperature.

**To determine if the thermostat is modulating properly, proceed with the following test:**

(1) Connect a 0-29 inch hg. vacuum gauge into the black with red tracer vacuum line at the thermostat using a "tee" connector. When disconnecting vacuum lines, twist and pull at the same time to avoid stretching the hose.

(2) Install the auto-temp tester as shown in Fig. 2, adjust the control vacuum to about 5 inches and de-



NU515

**Fig. 4—Control Unit Assembly**

press the "Auto" button on the instrument panel.

(3) Start the engine and allow it to run until it has attained normal operating temperature. Record vacuum to water valve.

(4) Press the "Hi Defrost" button and allow the defroster discharge air to become hot. The control vacuum should increase to at least 12 inches.

(5) Press the "Auto" button. The control vacuum should return to about 5 inches and the water valve vacuum should drop close to zero. As the air temperature stabilizes, the water valve vacuum should return to about the same reading acquired before pressing the "Hi Defrost" button.

(6) If the thermostat does not modulate properly, it cannot be repaired; it must be replaced.

**To determine if the thermostat is controlling properly, proceed with the following calibration test:**

With the engine off and the auto-temp tester connected;

(1) Disconnect and plug off the black with red tracer vacuum line at the thermostat. In its place, connect a 0-29 inches hg. vacuum gauge. When disconnecting vacuum lines, twist and pull at the same time to avoid stretching the hose. With the vacuum control dial and vacuum gauges, a certain input vacuum to the thermostat can be maintained and the thermostat output vacuum can be read.

(2) Disconnect compressor clutch wire in engine compartment. This will prevent compressor operation.

(3) Place a thermometer in the center of A/C outlet grille with outboard spot coolers closed.

(4) With the system in the "Auto" position, start the engine.

(a) Set the system to high blower and A/C mode.

(b) Engine speed should be at idle rpm.

(5) With the vacuum control dial, set the vacuum input to the thermostat at 7.0 inches Hg.

(6) Allow discharge air temperature to stabilize, it

should be approximately the same as the room ambient temperature.

(7) After the temperature has stabilized, read the thermostat output vacuum. Determine if the thermostat is calibrated properly from the chart. If the thermostat is out of calibration, it should be replaced.

### WATER VALVE THERMOSTAT CALIBRATION CHART

For 7 in. Hq. Input Vacuum

Temp. °F A/C Outlet	Output Vac. (± .5) In. Hq.	Temp. °F A/C Outlet	Output Vac. (± .5) In. Hq.
65	7.0	85	5.6
66	7.00	86	5.5
67	6.9	87	5.5
68	6.8	88	5.4
69	6.8	89	5.4
70	6.7	90	5.3
71	6.6	91	5.2
72	6.6	92	5.2
73	6.5	93	5.1
74	6.4	94	5.0
75	6.4	95	4.9
76	6.3	96	4.9
77	6.2	97	4.8
78	6.1	98	4.7
79	6.1	99	4.6
80	6.0	100	4.6
81	5.9	101	4.5
82	5.9	102	4.5
83	5.8	103	4.4
84	5.7		

### WATER VALVE (Fig. 5)

The water valve is vacuum operated and with the thermostat controls the discharge air. It requires checking, mainly to see if it is opening and closing fully.

This check can be accomplished as follows:

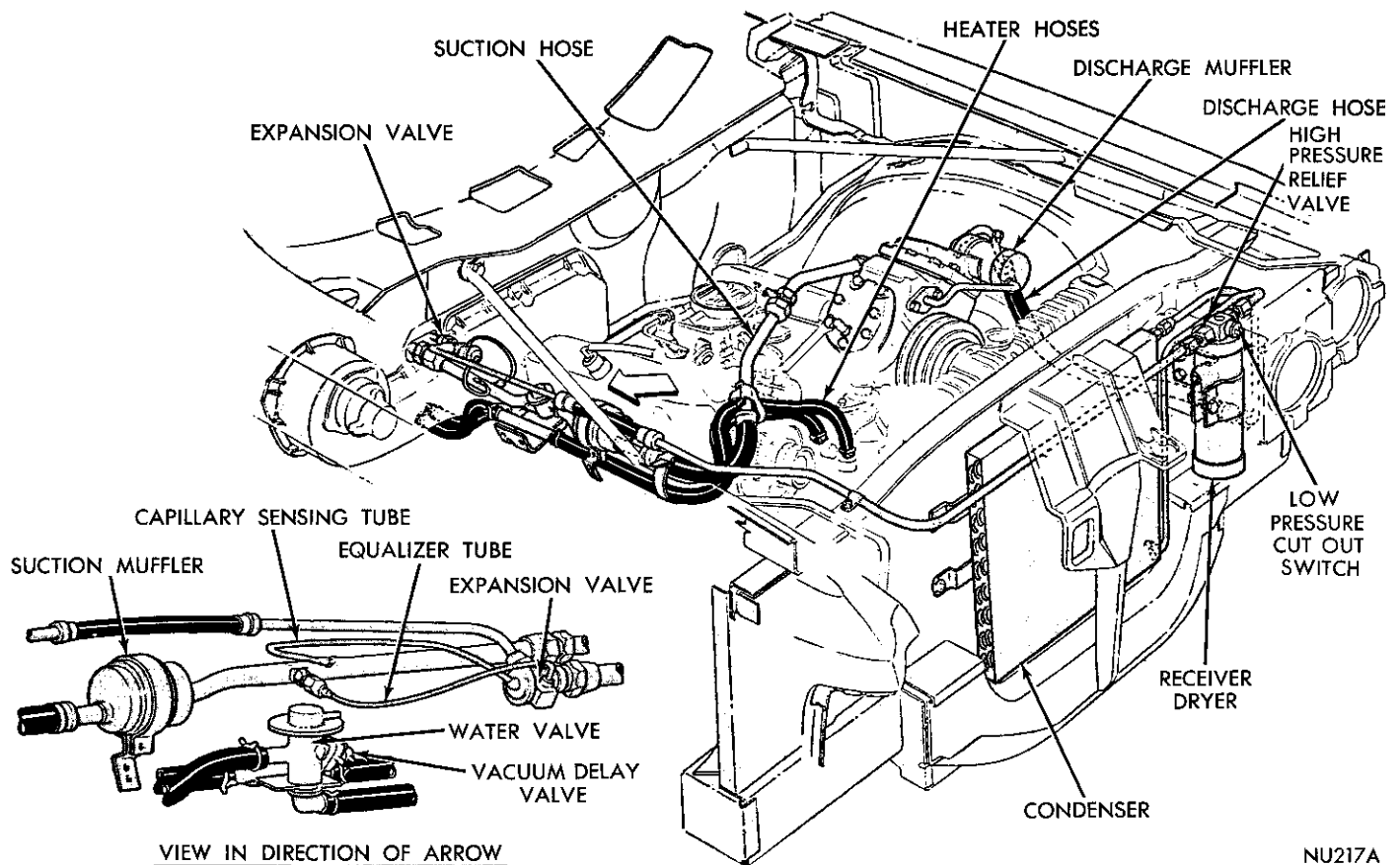
(1) With the engine fully warm (at least 180° F. water) and at 1000 rpm, hood closed, system in Auto and Control Dial in minimum vacuum position, remove vacuum hose, black with red tracer, from thermostat and leave it vented. This will vent any vacuum to the water valve and it should be fully closed.

(2) Place a thermometer in center A/C outlet grille. Air temperature should drop to minimum (should be in the low 40°).

(3) With an external vacuum source, apply 3.5 inches Hg. to the water valve at the black with red tracer hose that was pulled off the thermostat. There should be no increase in discharge air temperature.

(4) Increase vacuum to water valve to 4.5 inches Hg. and observe a slight increase in discharge air. This increase should be about 10°F.

(5) Finally apply full vacuum (at least 12 inches



**Fig. 5—Auto-Temp Plumbing (Imperial)**

Hg.) to water valve and observe temperature. It should rise rapidly to maximum, approximately 140°F.

If the valve did not pass any of the above tests, it is defective and should be replaced.

### THERMOSTATIC VACUUM DELAY VALVE

The valve is an integral part of the water valve, and it is controlled by a wax pellet that is sensitive to water temperature. The valve prevents the start of the blower (by not allowing the vacuum circuit to the blower master switch to be completed) on Auto and Hi-Auto when heat is required until the engine water temperature increases.

A functional check of the valve can be made only when the system is in the Auto position requiring heating, and the engine is cold.

Connect a vacuum gauge to the outlet port of the delay valve. The valve will remain at zero inches vacuum until the engine coolant increases to 125° ± 5° F. at this point the gauge reading will increase to full slave circuit vacuum. The temperature indicator on the vehicle's instrument panel can be used to estimate coolant temperature.

When it has been definitely determined that vacuum delay valve is faulty, the entire water valve assembly must be replaced.

### VACUUM TRANSFER SWITCH

This three port vacuum transfer switch, a spring, and a regular vacuum actuator, combine to give the fresh/recirculating door 3 positions (Off or 0% fresh air, 20% fresh air, and 100% fresh air).

(1) Push the system Off button and start engine. Observe the following:

(a) Fresh/Recirculating Air Door is on 0% fresh air.

(b) Switch Plunger is retracted and touching lever.

(2) Disconnect solid black vacuum line at thermostat and leave it vented. Push the Auto button. Observe the following:

(a) Fresh/Recirculating Air Door is on 20% fresh air.

(b) Switch plunger has moved out but is still contacting lever.

Reconnect vacuum hose to thermostat after this check.

(3) Remain in Auto and set dial control to warmest position 85. Observe the following:

(a) Fresh/Recirculating Air Door is on 100% fresh air.

(b) Switch plunger has moved all the way out and is no longer in contact with lever.

If all of the above occurred as stated, the switch is

operating properly. If they did not, proceed as follows:

(1) Push the system Off button, leave engine running.

(2) Remove 3 port vacuum plug from transfer switch and connect a vacuum source to the middle port of the switch. Do the following:

(a) Depress plunger all the way in and check for absence of vacuum at the right port (one closest to lever) and absence of vacuum at the left port.

(b) Release plunger and check for absence of vacuum at the left port and presence of vacuum at the right port.

If the above did not occur as stated, the transfer switch is faulty and should be replaced.

### BLOWER MASTER ON-OFF SWITCH

The master switch is vacuum operated and turns on the blower. A magnet mounted inside the switch holds the electrical contacts open. When sufficient vacuum is applied an internal diaphragm with attached electrical contact is pulled away from the magnet and the electrical circuit is completed.

This switch can be checked by applying  $8 \pm 1$  inch Hg. vacuum to it with an external vacuum source and checking for electrical continuity, and by removing the vacuum source and checking to see that it opens at less than 5 inches Hg. vacuum. The resistance of this switch can be checked by measuring the voltage of this motor when the system is in Hi-Blower air conditioning. If the motor voltage is low, and it can be corrected by replacing the master switch with a jumper, the switch should be replaced.

### COMPRESSOR VACUUM SWITCH

This switch is vacuum operated and turns on the compressor (if the ambient switch is closed). It is identical to the blower master switch except in that it closes at  $2 \pm 1$  inch Hg. vacuum and completes the electrical circuit to the compressor clutch. The switch is actuated immediately in any push-button position except Off.

The performance of the switch can be checked by applying  $2 \pm 1$  inch Hg. vacuum with an external vacuum source and checking for electrical continuity then removing the vacuum source and checking to see that it opens. The resistance of the switch can be checked by measuring the voltage at the clutch any time the compressor should be running. If the clutch voltage is low, and can be corrected by replacing the switch with a jumper, the switch should be replaced.

### AMBIENT SWITCH

The compressor ambient switch completes the elec-

trical circuit to the clutch, ETR switch, and ETR solenoid if the ambient temperature is above  $32^{\circ}\text{F}$ . The operation of the compressor down to  $32^{\circ}\text{F}$ . provides a smooth transition for incoming air, and adds to comfort by also dehumidifying in cool, damp weather.

Due to its location, the switch will become heated periodically during the winter season by brief shut-downs of the Auto-Temp system or the engine. On restart, the compressor will operate for brief period and, thereby, allows the shaft seal to be lubricated automatically.

The ambient switch can be checked by removing it and checking for continuity at a temperature slightly above  $32^{\circ}\text{F}$ ., and for being open at temperatures slightly below  $32^{\circ}\text{F}$ .

### ANTI-FROST CONTROLS

This control consists of 2 parts: ETR Valve Solenoid and ETR Switch.

The anti-frost control is a device which allows the evaporator to maintain a minimum air temperature, without allowing the moisture on the fins to freeze, down to ambient temperatures of approximately  $32^{\circ}\text{F}$ . This ETR (evaporator temperature regulator) control was chosen for the Auto-Temp system because the EPR used on Standard A/C cars would not prevent coil freeze-up at the lower ambient temperatures at which the compressor is required to operate. The ETR consists of the electrical solenoid which is actuated by the temperature switch which senses coil fin temperature.

The ETR solenoid can be checked simply by energizing it directly off the battery and listening for its closing.

The ETR switch (Fig. 6) can be tested for operation as follows:

- (1) Set thumbwheel potentiometer below 65.
- (2) Connect a test light in series with the ETR switch feed wire at the compressor.

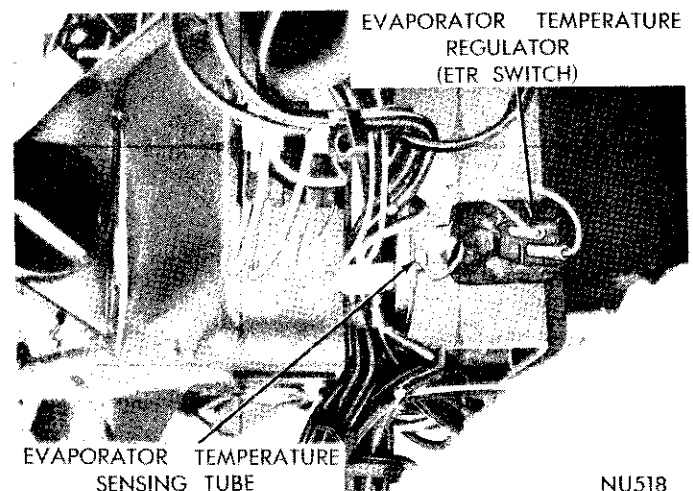


Fig. 6—ETR Switch Location

(3) Connect a three gauge manifold, Tool C-3740 (Fig. 7), with suction and discharge valves closed.

(4) Start engine and set at 1000 RPM. Close all car doors and windows and press Auto button.

(5) Allow engine to run about 5 minutes and compare gauge readings with switching action of ETR switch.

Test Light	Evaporator Suction Gauge	Discharge Pressure Gauge	Compressor Inlet Gauge
OFF	22	180	30
ON	30	150	0 or Below

Head pressure may vary, but a 25 to 30 pound pressure differential will show during switching action of the ETR switch.

**ETR SOLENOID VALVE**

The ETR valve is a precision part, with extremely small operating clearances. The presence of foreign material between the two sleeves can cause the valve to stick. It is, therefore, imperative that every effort be made to protect the valve from contaminants.

**Replacement**

(1) Discharge system as outlined in A/C section of this manual.

(2) Disconnect 12 volt D.C. lead from the ETR terminal gasket at the suction fitting.

(3) Remove the 2 bolts holding the suction fitting to the compressor, and remove the fitting.

(4) Remove the terminal gasket from the compressor, and discard.

(5) Scrape off any gasket particles remaining on the crankcase and suction fitting, working from the center outwards, thereby reducing the possibility of contaminating the compressor. If the system check had indicated a lack of electrical continuity, place a short length of 1" diameter tubing against the rear face of the ETR valve collar, and tap lightly, to ensure good contact between the compressor and the chamfered surface of the valve collar. Check the valve for operation by applying 12 volts D.C. to the valve terminal post.

(6) Remove the valve from the compressor, using Tool C-3301A (Fig. 8). Recheck the valve for operation, by connecting 12 volts D.C. to the valve terminal post. The valve should close when grounded at the bottom of the outer sleeve.

**CAUTION: Do not energize the valve continuously for more than 30 seconds. If the valve is still inoperative, replace it.**

(7) Inspect the suction annulus for foreign material, and ensure that the plug in the ETR oil bypass

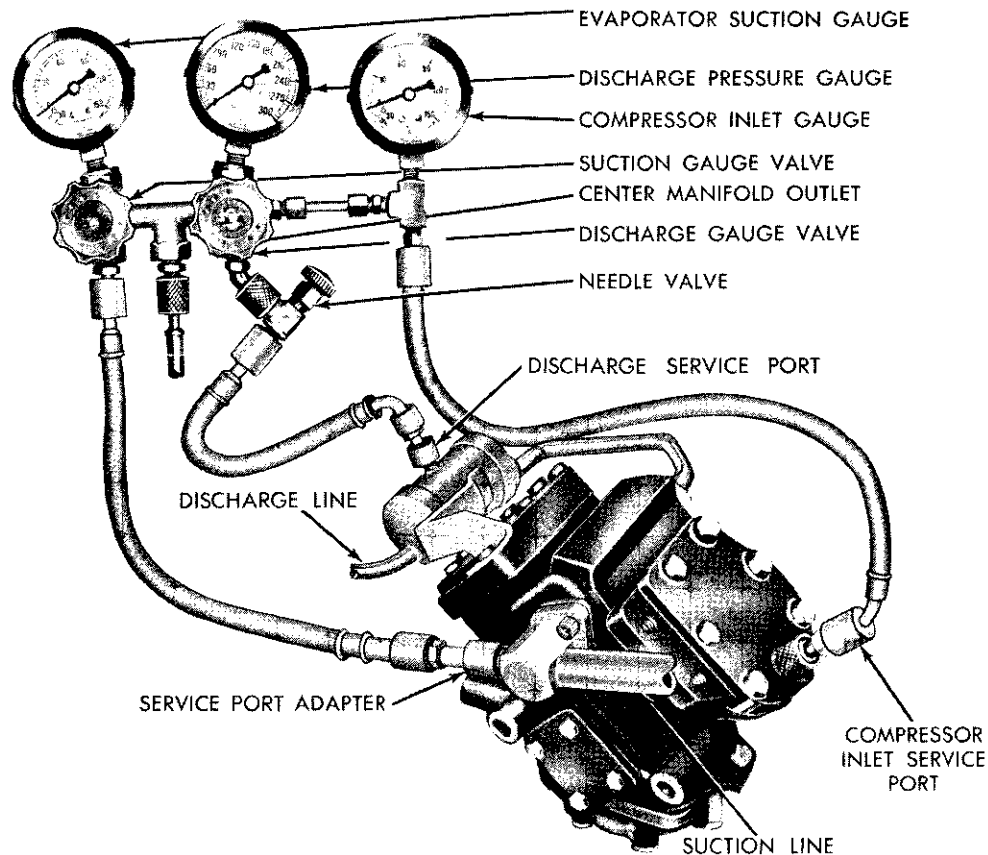
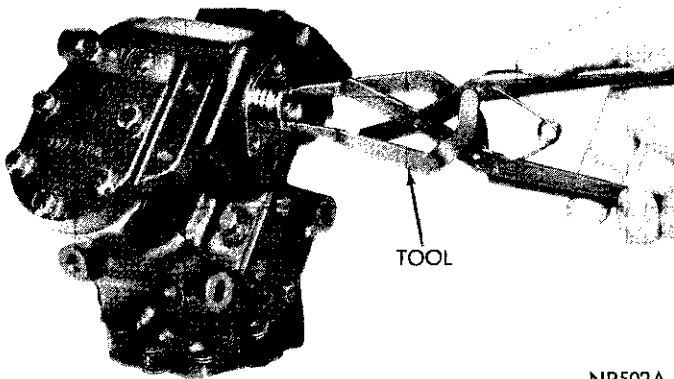


Fig. 7—Gauge Set Manifold Connections



**Fig. 8—Removing ETR Valve**

is pushed below the machined surface of the ETR cavity.

(8) Check for valve operation by clamping a 12 volt D.C. lead to the terminal post and gently tapping the bottom of the valve against a clean grounding surface.

(9) Using Tool C-3301A, insert the ETR valve as far as possible into the suction annulus. Gently tap the valve in as far as it will go, using the tool previously described.

(10) Coat both the suction fitting and compressor crankcase mating surfaces with a light coating of clean refrigerant oil.

(11) Install new terminal gasket so that the copper terminal spring slips over the terminal post of the ETR valve.

(12) Torque the suction fitting bolts to 11 foot-pounds in small equal increments, to ensure proper seating on the gasket. Check for continuity and operation by applying 12 volts D.C. to terminal.

(13) Charge the system with refrigerant-12 and check for refrigerant leaks.

(14) Reconnect 12 V D.C. lead from anti-freeze switch to ETR valve at the terminal gasket. Check system for proper operation.

## TEMPERATURE CONTROL DIAL

The control dial allows the operator to select an interior comfort level by selecting a number from 65 to 85. Movement of the dial controls a resistance potentiometer, which is part of the dial assembly. There is a calibration between the dial temperature and the potentiometer resistance. The potentiometer will put out the proper biasing resistance signal to the control system so that it will control at the selected interior temperature.

There are 3 basic problems which may occur with the control dial potentiometer assembly. These are listed along with the system malfunction symptom.

(1) **Potentiometer could be open**—System would operate on maximum A/C and high blower only.

(2) **Potentiometer could have a short**—System would operate on maximum heating and high blower only.

(3) **Dial and Potentiometer could be out of calibration**—Dial must be set too high or too low to attain comfort.

Checking the above can be accomplished as follows:

(1) To check the dial potentiometer for an open or short, disconnect potentiometer leads (violet color) and connect them to an ohmmeter (Simpson model 260 series 4, volt-ohm milliammeter, or any equivalent ohmmeter can be used). Observe the following:

(a) If meter shows infinite resistance, the potentiometer is open and should be replaced.

(b) If meter shows zero resistance, the potentiometer has a short.

(c) If potentiometer is good, there should be a smooth change in resistance from approximately 50 to 550 ohms in dial rotation from 85 to 65. If not, potentiometer should be replaced.

(2) To check the dial control calibration, set the dial to 75 at center of Bezel. The meter should read 300 ohms. If it is out of calibration, it can be adjusted as follows:

(a) Rotate dial so that meter reads 300 ohms.

(b) Hold potentiometer shaft as shown in Fig. 10 and slip dial so that number 75 is on center of Bezel.

After completing work on the control dial assembly, be sure to reconnect all wiring.

## IN-CAR SENSOR

The in-car sensor is located in a removable grille so that check or replacement can be accomplished. It senses car interior temperature and automatically signals the control unit to compensate for any variation from the selected dial temperature.

There are two basic problems which may occur with the sensor. These problems and the system malfunction symptoms are:

(1) **Sensor could be open**—System would operate on maximum heating and high blower only.

(2) **Sensor could have a short**—System would operate on maximum A/C and high blower only.

The above can be checked in the same manner as the control dial potentiometer.

If the sensor is defective, check connections, repair or replace as necessary. The calibration cannot be checked without extensive measuring techniques. If the sensor is suspected to be out of calibration, a new sensor may be tried, but it is considered very doubtful that this will occur.

## AMBIENT SENSOR

This sensor senses the outside ambient temperature. It makes adjustments to the system that are

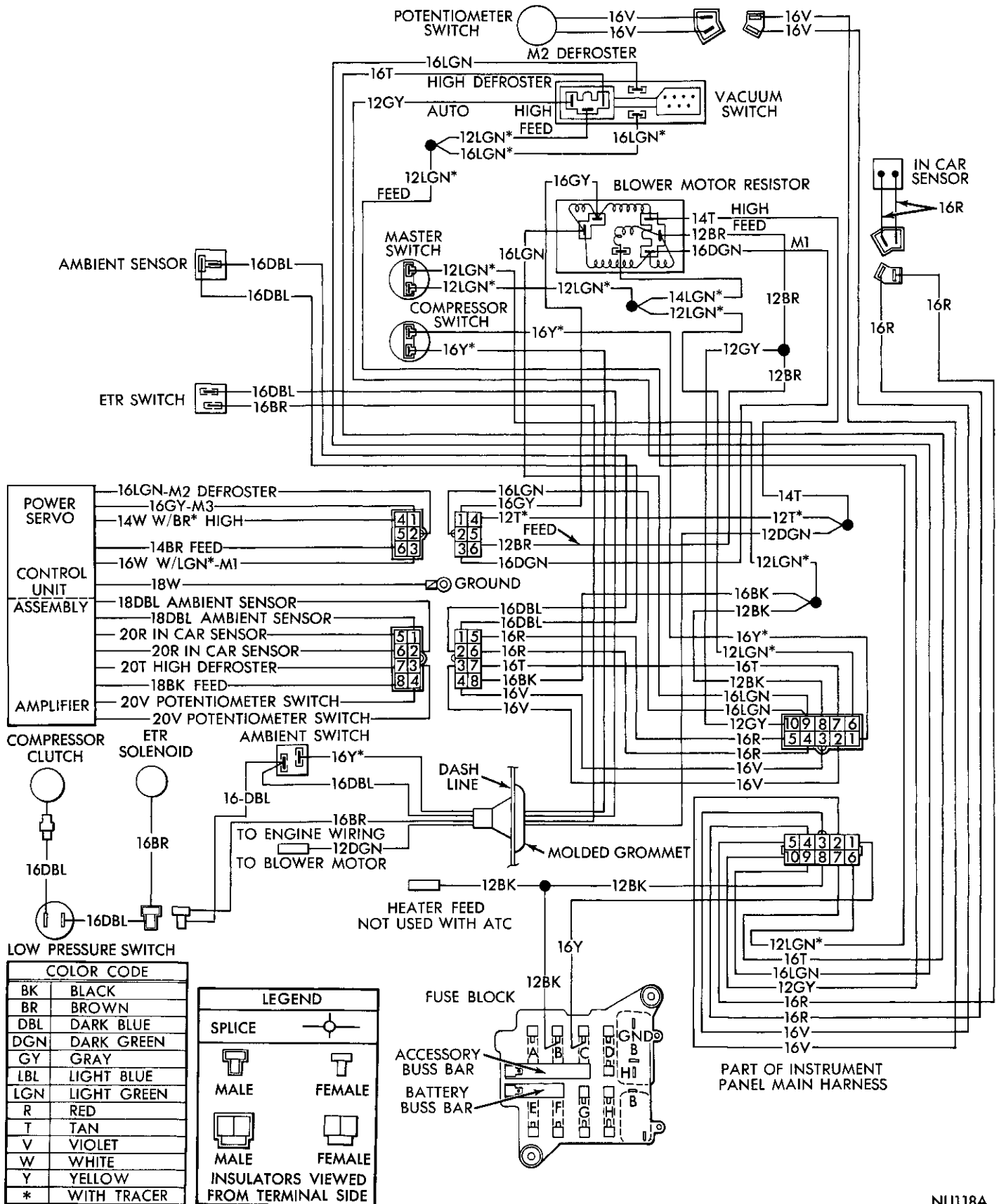


Fig. 9—Auto-Temp Wiring Diagram

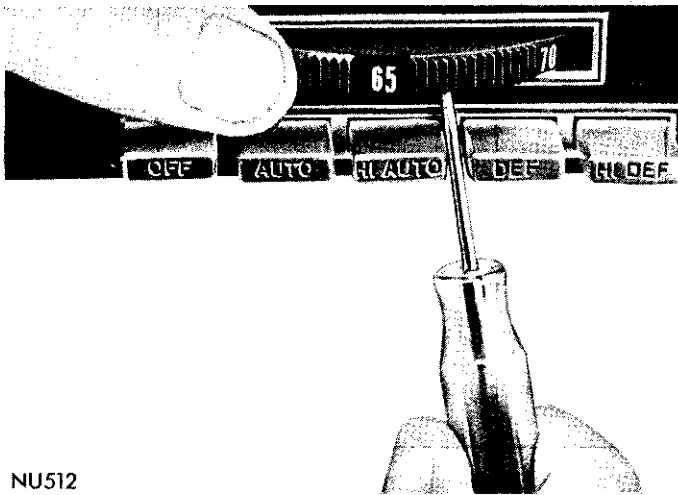


Fig. 10—Thumbwheel Calibration

required to maintain a constant interior comfort level due to ambient temperature changes.

There are two basic problems which may occur with this sensor, also. The problems and system malfunction symptoms are as follows:

(1) **Sensor could be open**—System operates on heat mode at all times.

(2) **Sensor could have a short**—System operates on maximum A/C and high blower only.

These deficiencies are checked in the same manner as for the in-car sensor. If sensor is faulty as described, repair or replace as necessary. A calibration check of this sensor is also difficult, therefore a new sensor may be tried in the system if it is suspected.

## ASPIRATOR

The aspirator is a tube shaped device connected to the passenger side housing in such a manner that air flowing through the housing creates a slight vacuum in the aspirator. The aspirator is connected to the in-car sensor by a flexible tube. The vacuum in the aspirator tends to pull in-car air over the sensor.

### Aspirator and Tube Test

With air flowing through the passenger side housing the aspirator should pull air into the in-car sensor grill. This can be checked by holding a smoking object (cigarette) next to the grille with the system on M3 blower in heat mode. If smoke is not pulled into the grille the aspirator is not working properly. The aspirator and tube must be inspected for incomplete connection or kinks.

## VACUUM RESERVOIR TANKS

There are two reservoir tanks: Slave System Vacuum Tank and Servo System Vacuum Tank.

Both reservoir tanks are used for the purpose of

maintaining sufficient vacuum in the system in cases where source vacuum is lost momentarily. Each tank has a check valve at the inlet port which closes when the vacuum supply drops off.

Operation of both tanks is checked in the same manner:

(1) Connect a 0-29 inch Hg. vacuum gauge to outlet port of tank.

(2) Start engine and allow to run at idle speed.

(3) Vacuum at gauge should build up above 20 inch Hg. in less than one minute.

(4) Shut engine off, and observe gauge.

(a) If vacuum does not drop off, the check valve and tank are operating satisfactorily.

(b) If vacuum drops off, there is a leak and tank assembly should be replaced.

## CHECK VALVES (Fig. 11)

Check valves are used in the Auto-Temp system to prevent the venting of certain vacuum circuits, when the vacuum supply is lost or removed.

The check valves, which are an integral part of the reservoir tanks, are discussed in the vacuum reservoir tank check-out procedure. There are two other check valves in the vacuum system. These two valves are a part of the vacuum harness assembly, and are located in the area where the harness routes under the passenger side housing. The valves are spaced apart on the harness, and for identification, they will be referred to in sequence as numbers 1 and 2; where number 1 is the closest to the control unit assembly.

Each check valve also serves as a “tee” connector, thereby eliminating extra connections. On the body of each valve is an arrow which points to the port or ports being checked.

### Test Procedure For Check Valves

The following is presented as an aid for diagnosing check valve failures:

(1) The most probable types of failures with check

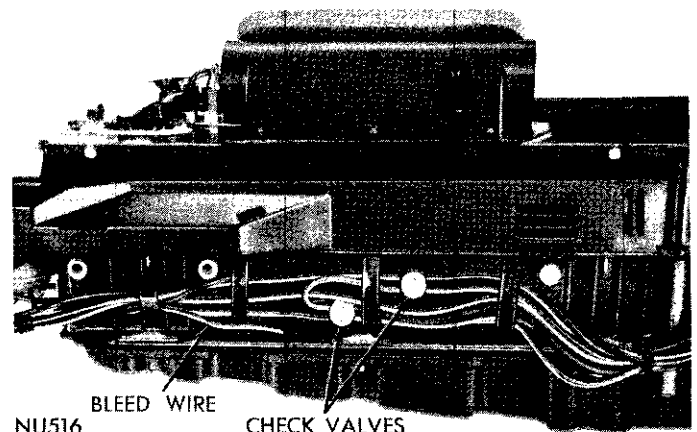
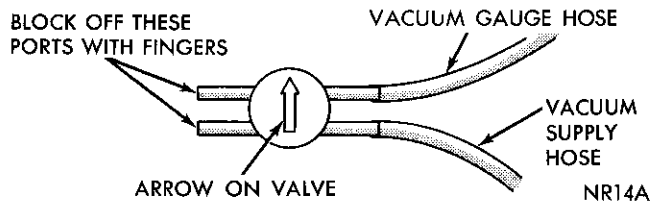


Fig. 11—Check Valves (Bottom View of Housing)





**Fig. 12—Vacuum Check Valve Test**

valves are leakage and incorrect installation. The malfunctions created by faulty check valves are:

**Check Valve Number 1 Leaking:** System stays on 20% fresh/air and will not go to 100% fresh/air. Also, system shuts off when vacuum supply is lost.

**Check Valve Number 1 Installed Backwards:** System malfunctions the same as with a leaking valve. Also, with a cold engine the blower will not come on when the “Defrost” or “Hi-Defrost” button is pushed.

**Check Valve Number 2 Leaking:** Blower starts immediately and blows cold air during cold weather.

**Check Valve Number 2 Installed Backwards:** Blower starts immediately and blows cold air during cold weather. With the engine cold the blower will not shut off when the “Off” button is pushed.

(2) When check valve failure is suspected, the following should be done:

(a) Inspect harness to see that valves are installed correctly as in (Fig. 11).

(b) Remove any valves which are suspected to be faulty, and check as follows:

Connect a vacuum gauge and supply vacuum to valve as shown (Fig. 12).

Apply full vacuum attainable from car or from an external source. Note vacuum at gauge and remove

vacuum supply hose. The reading should have remained approximately the same. If vacuum is dropping off at the gauge, the check valve is faulty. Change any valves which are found faulty and check out system to see if malfunction has been corrected. It should be noted that the most severe test on a check valve is below freezing weather. It is possible that a defective valve will not work in such weather, but work at room ambient temperatures.

**CAUTION:** Do not use a lubricant of any type to attempt to increase the efficiency of faulty check valves as serious damage will result to the entire vacuum system.

**System Vacuum Leak Test**

(1) “Tee-in” a 0 to 30 inch vacuum gauge at the master switch (green color coded) vacuum connection.

(2) With the “Auto” button depressed, place system on Heat mode by rotating tester vacuum control dial to maximum vacuum.

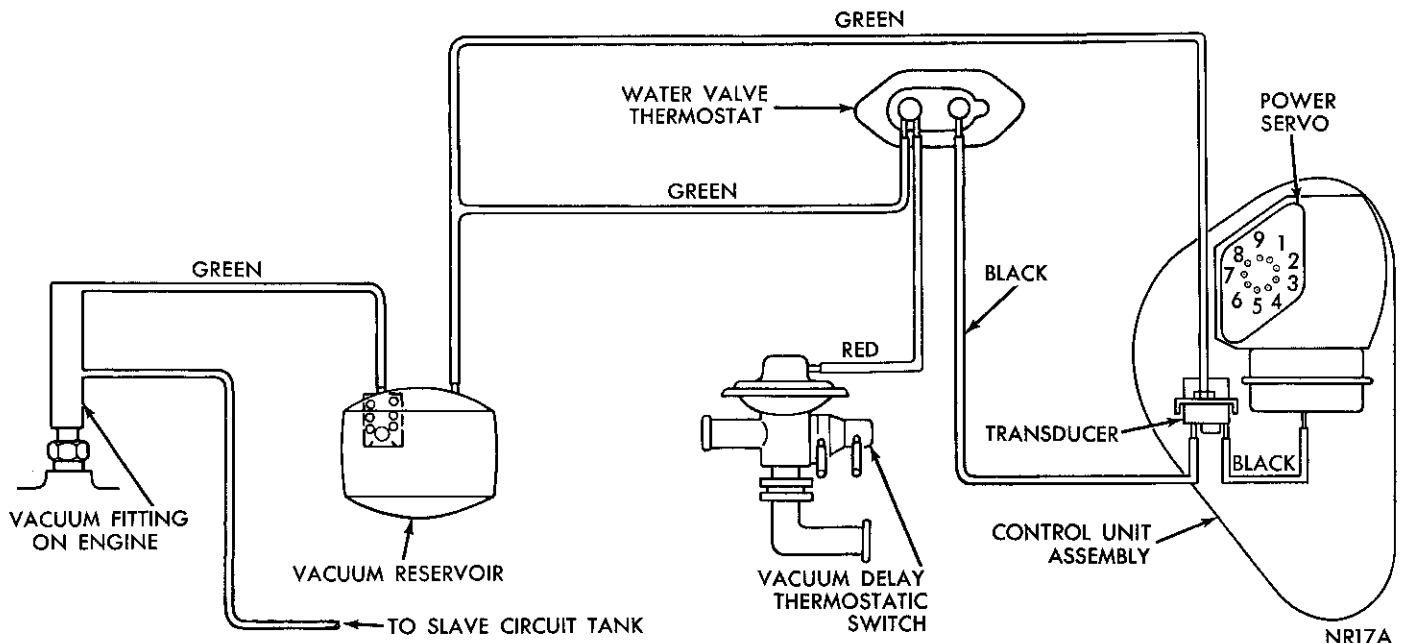
(3) Allow vacuum at master switch gauge to build up to at least 18 inches and stabilize.

(4) Turn engine off and observe master switch gauge vacuum decay for one minute.

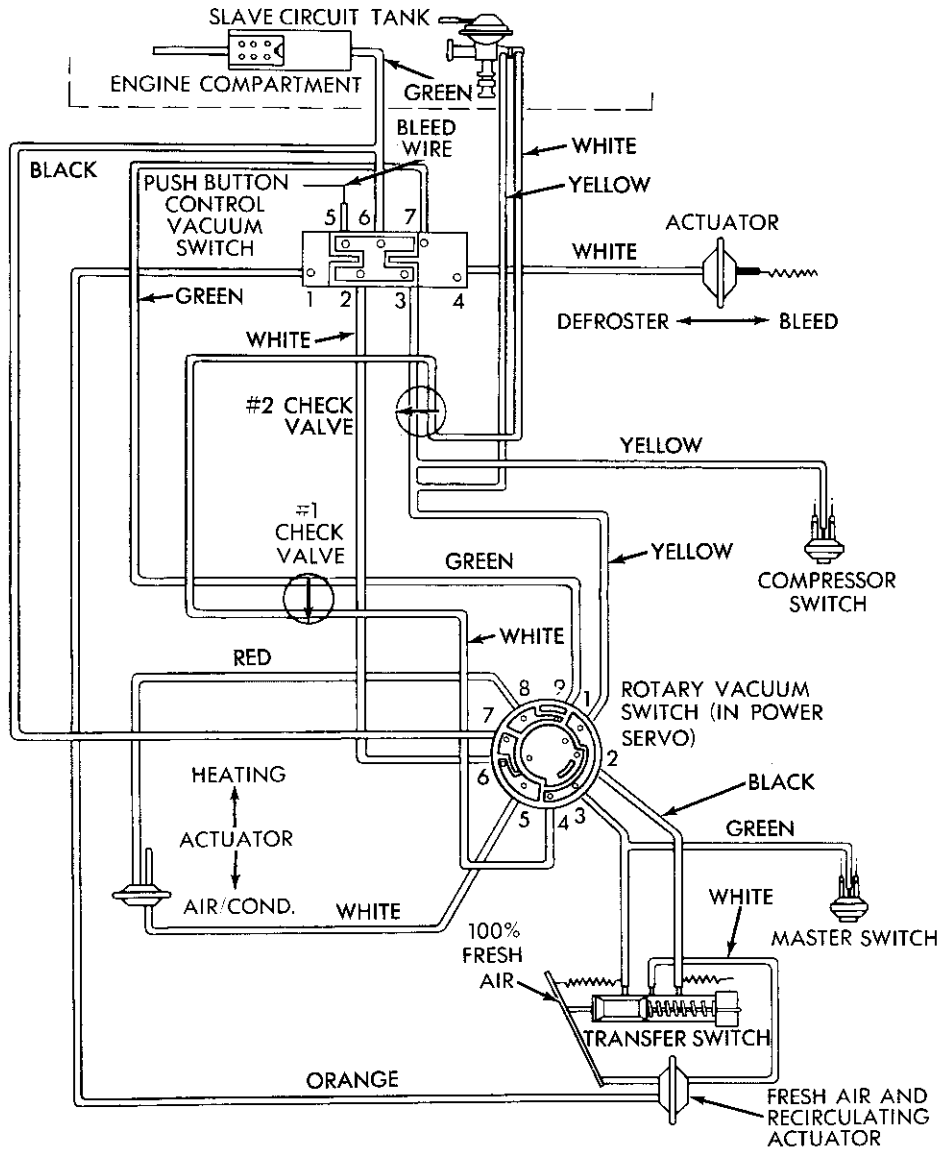
If the vacuum gauge did not build up to at least 18 inches vacuum with the engine running, or if the vacuum decay rate with the engine off exceeded 5 inches per minute, the system shall fail the performance test.

**Servo System Vacuum Leak Test**

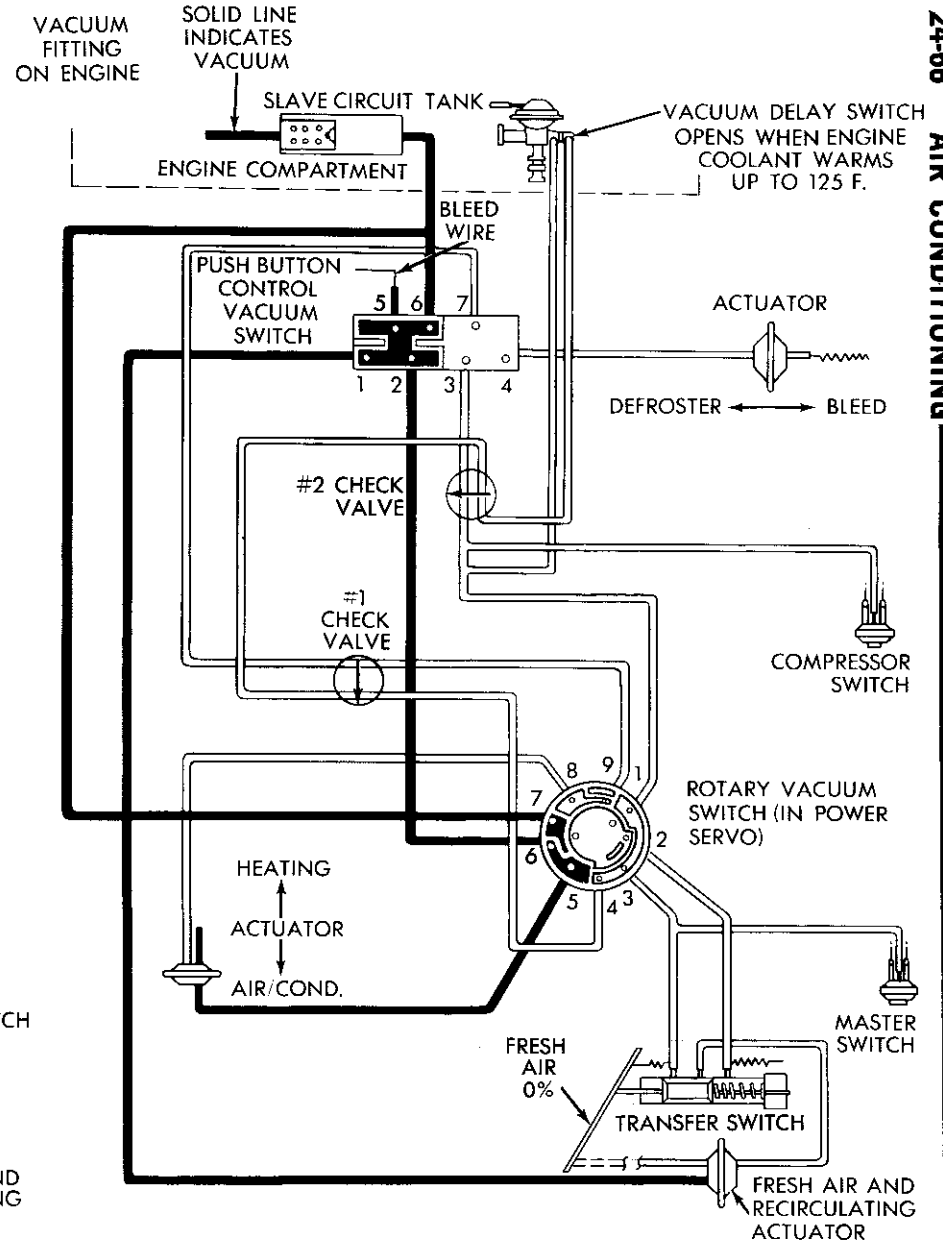
(1) With engine running, push the “Hi-Def” button.



**Fig. 13—Auto-Temp Control Vacuum Circuit**

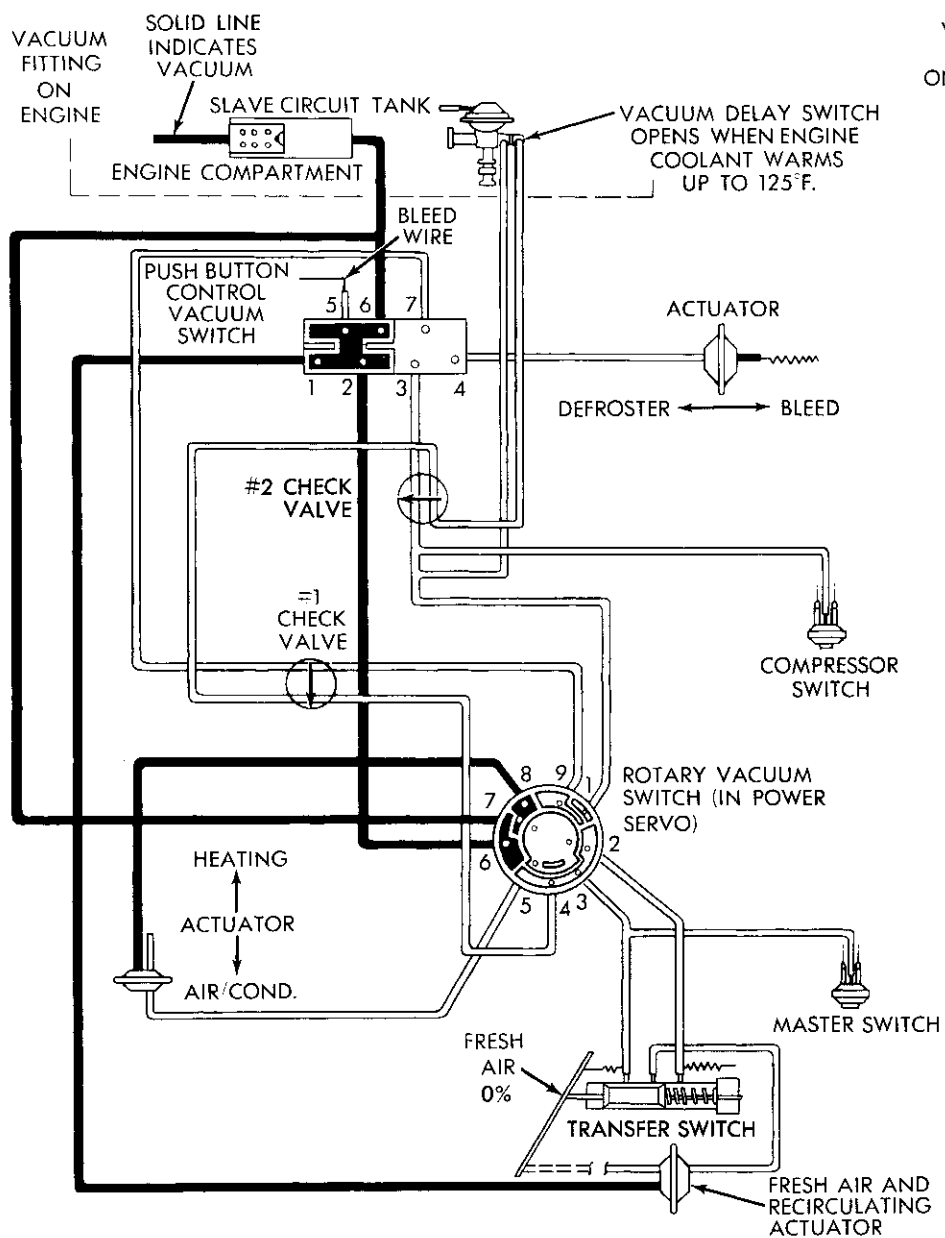


VACUUM HOSE COLOR CODE

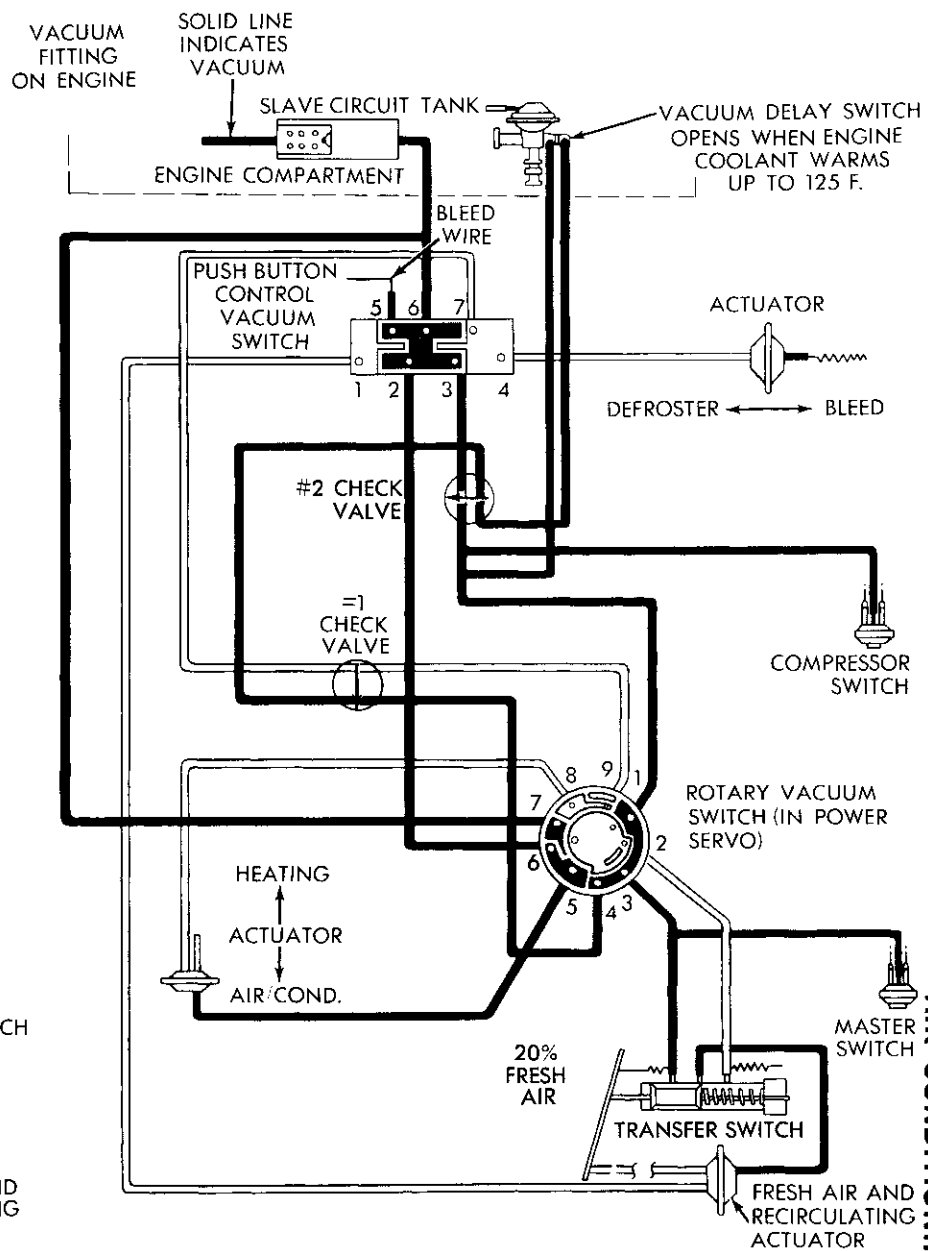


OFF POSITION AIR/COND-0% FRESH AIR

Fig. 14—Slave System Vacuum Circuit



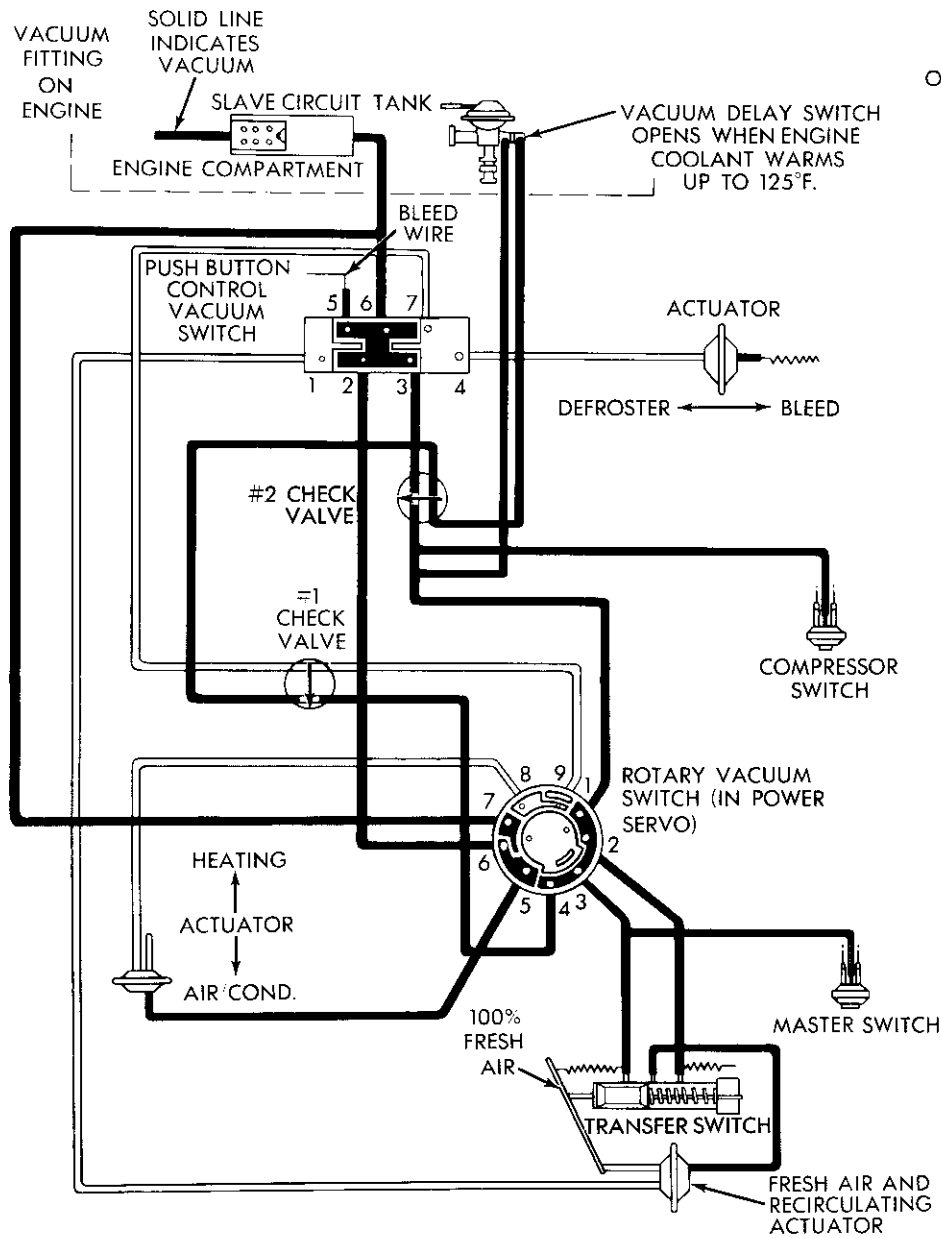
OFF POSITION HEAT-0% FRESH AIR



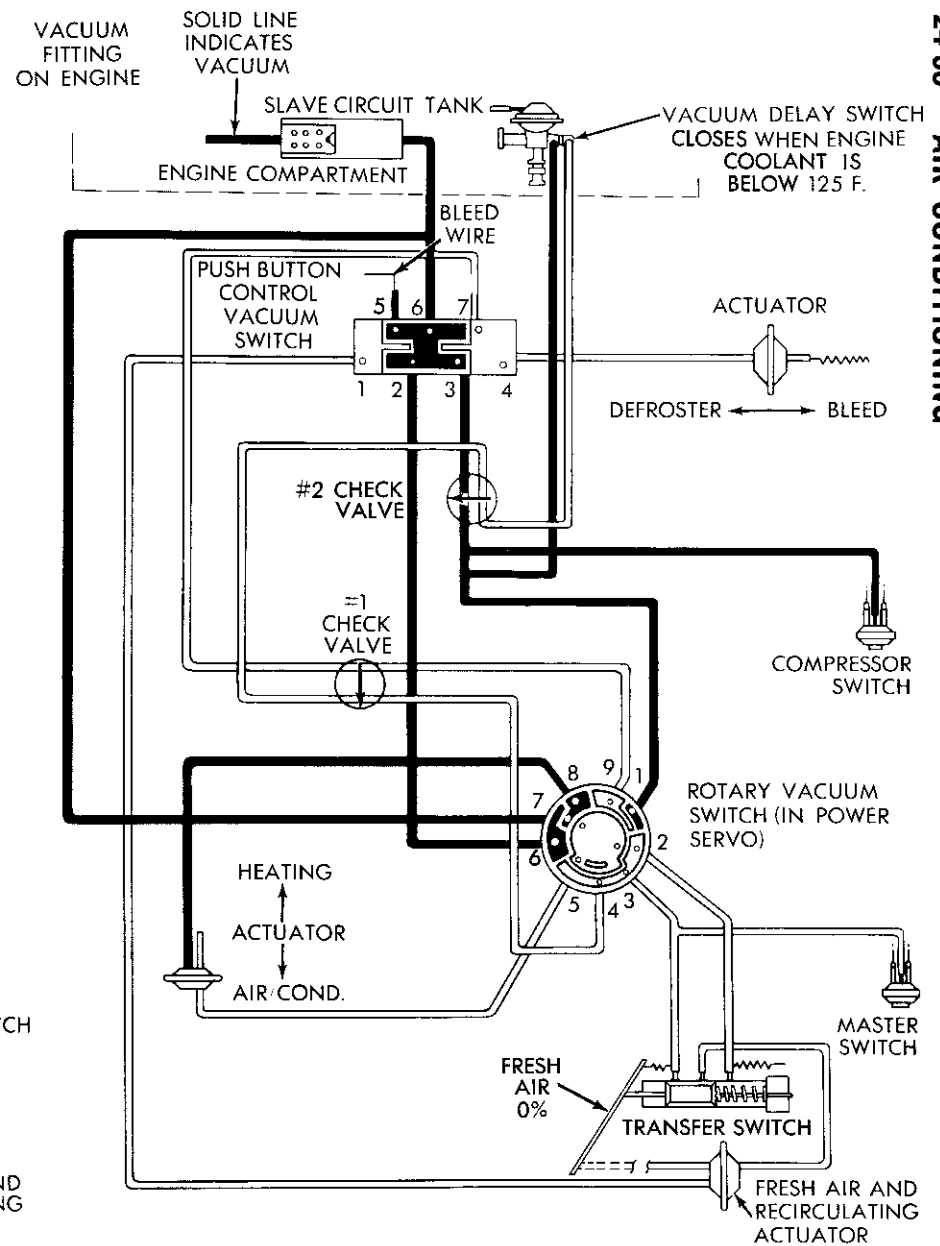
AUTO OR HI-AUTO AIR/COND-20% FRESH AIR

AIR CONDITIONING

**Fig. 15—Slave System Vacuum Circuit**

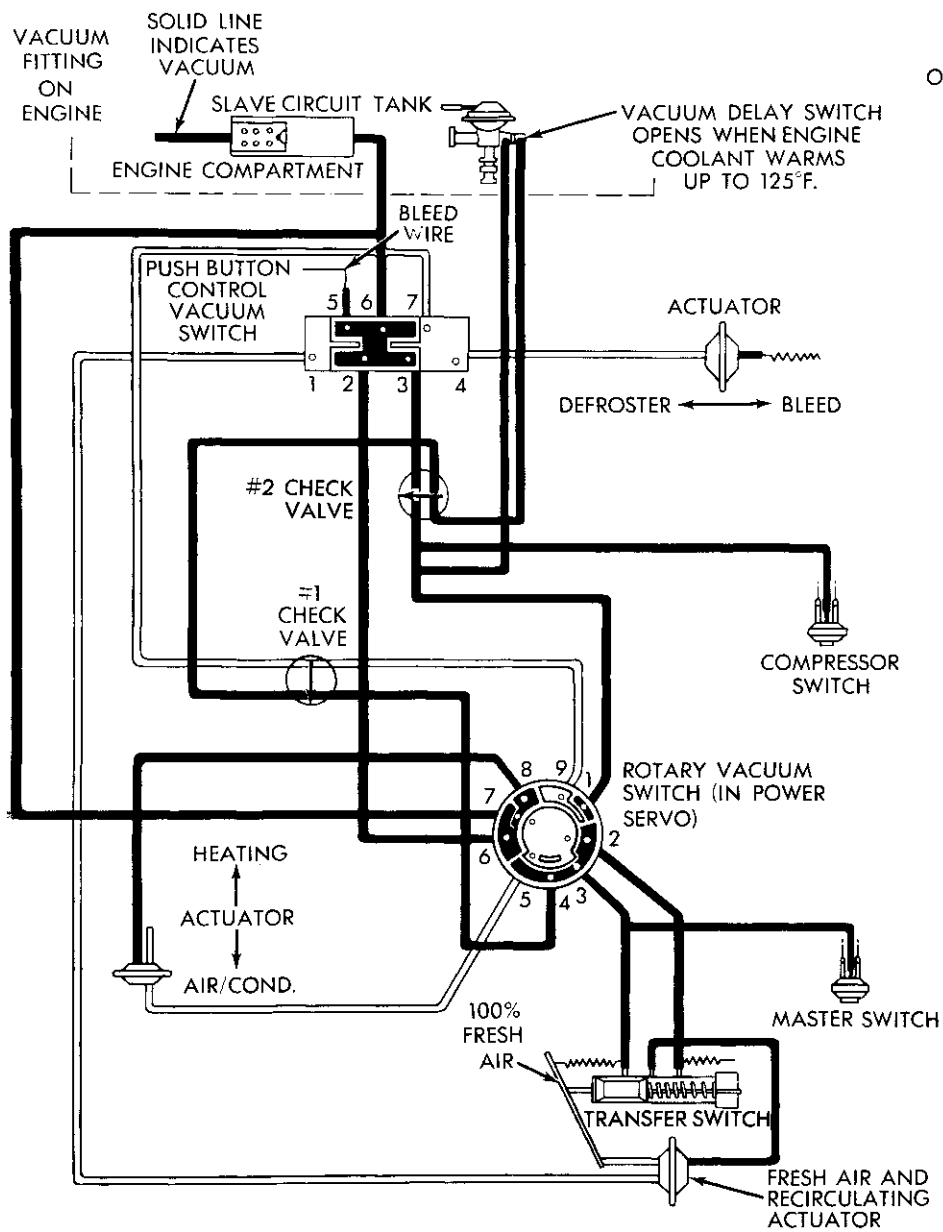


AUTO OR HI-AUTO AIR/COND—100% FRESH AIR

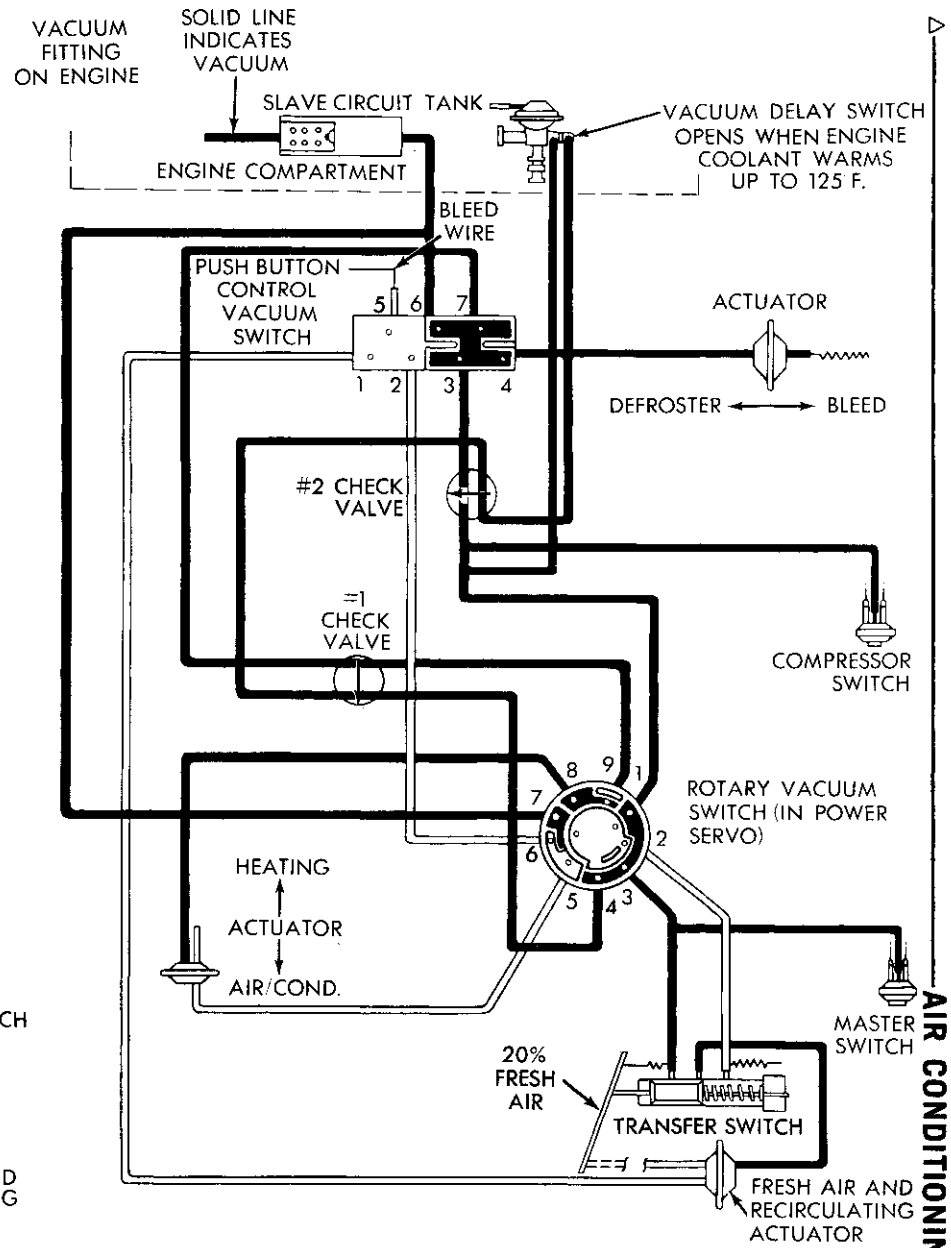


AUTO OR HI-AUTO HEAT 0% FRESH AIR  
(ENGINE TEMPERATURE BELOW 125°F)

Fig. 16—Slave System Vacuum Circuit



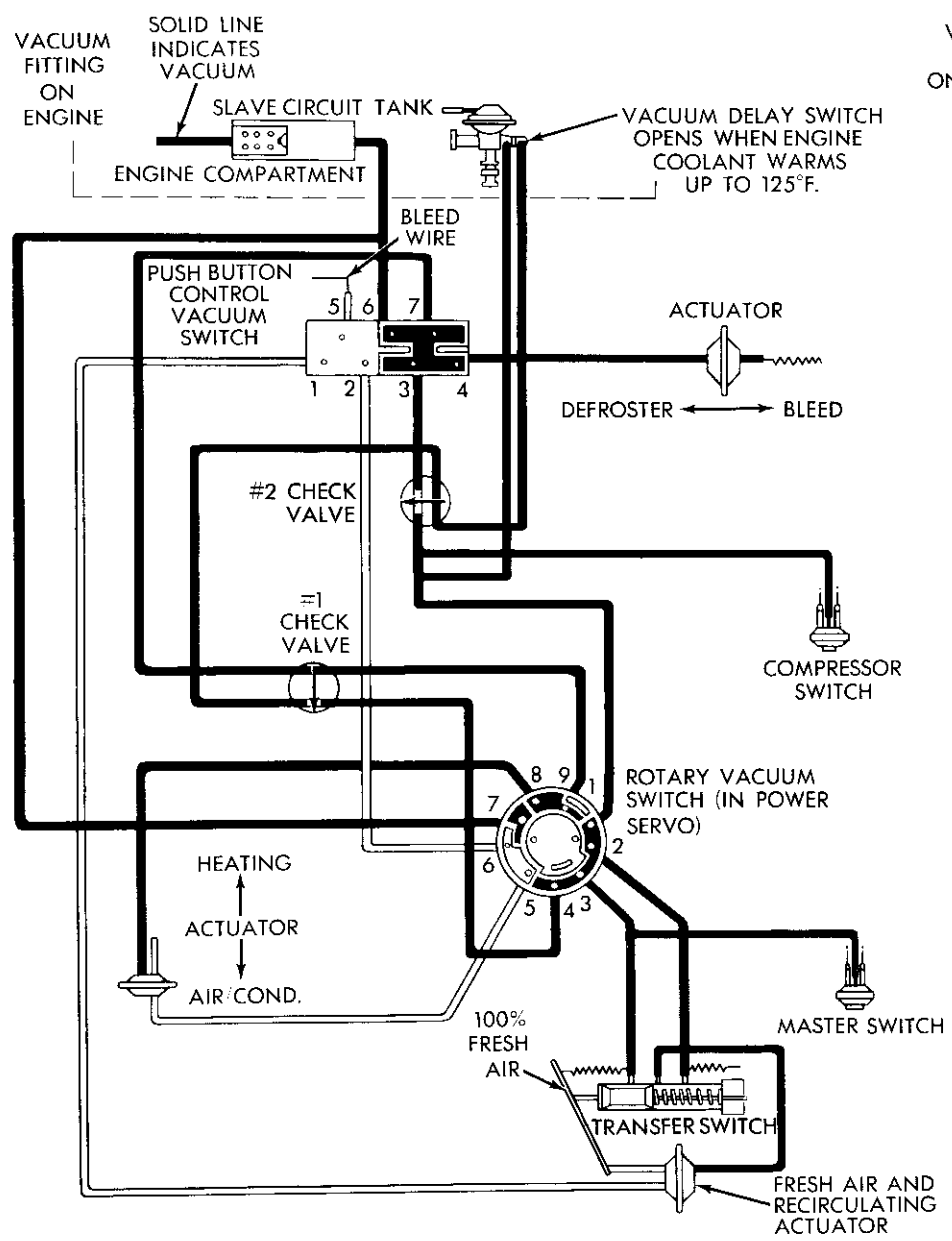
AUTO OR HI-AUTO HEAT—100% FRESH AIR  
(ENGINE TEMPERATURE ABOVE 125°F)



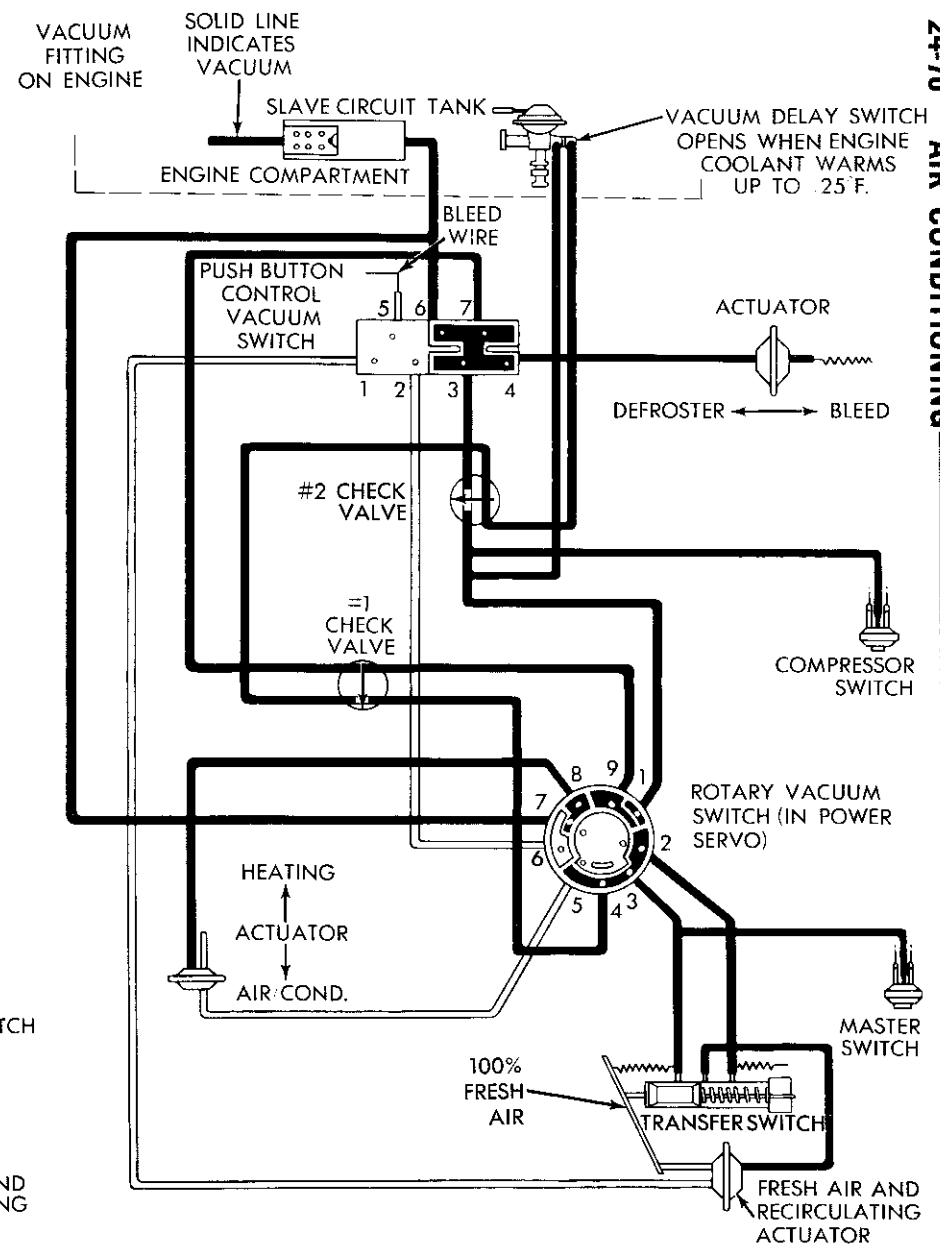
DEFROST AIR/COND—20% FRESH AIR

AIR CONDITIONING

**Fig. 17—Slave System Vacuum Circuit**



DEFROST AIR/COND—100% FRESH AIR



DEFROST OR HI-DEF HEAT—100% FRESH AIR

**Fig. 18—Slave System Vacuum Circuit**

(2) Observe that vacuum on tester gauge builds up above 15 inches and stabilizes.

(3) With engine running, pull off the vacuum supply hose to the servo system vacuum tank, and observe tester gauge vacuum decay for one minute.

If the vacuum decay rate exceeds 1 inch per minute, the system shall fail the performance test.

**VACUUM CIRCUITS FOR EACH PUSH BUTTON POSITION (Figs. 13 thru 18)**

When testing or adjusting the doors in the distribution system, it is necessary to know the correct position of each door for each push-button position. In the illustrations which follow; air flow is indicated, also which vacuum actuator hoses are activated for each push-button position.

With the use of the Service Diagnosis, Push Button Control Chart and Vacuum Circuit Diagrams, a quick and accurate solution to vacuum problems should be obtained.

**CAUTION: Do not use lubricant on switch prods or in vacuum hoses as lubricants will ruin the vacuum valve in the switch and cause check valves to fail. If it is impossible to properly position the connector plug all the way on the switch prods, put a drop or two of clean water in the holes of the connector plug. This will allow the plug to slide completely on switch prods.**

**PERFORMANCE TEST**

Humidity (the amount of moisture in the air) has an important bearing on the temperature of the air delivered to the vehicle's interior. This is true of all air-conditioned systems whether in the home, office or vehicle. It is important to understand the effect humidity has on the performance of the system. When humidity is high, the evaporator has to perform a double duty. It must lower the air temperature and the temperature of the moisture carried in the air. Condensing the moisture in the air transfers a great deal of heat energy into the evaporator fins and tubing. This reduces the amount of heat the evaporator

can absorb from the air. In other words, high humidity greatly reduces the evaporator's ability to lower the temperature of the air delivered to the vehicle interior.

Evaporator capacity used to reduce the amount of moisture in the air is not wasted. Wringing some of the moisture out of the air entering the vehicle adds materially to the comfort of the passengers. However, an owner may expect too much from his air-conditioning system on humid days. A performance test is the best way to determine whether or not the system is performing up to standard. This test also provides valuable clues to the possible cause of trouble. Install gauge set as shown in Fig. 7.

Connect Auto-Temp Tester, as shown in Figure 2. Place system in minimum vacuum position. System should be in the maximum cooling position (air conditioning, 20% F/A, and Hi/blower).

Put fresh/recirculating door in the 100% fresh/air position. This can be done by removing the glove box and the right spot cooler duct. Remove and plug the white vacuum hose on the pot side of the fresh/air door actuator. Connect an external vacuum source to the pot side of this actuator. Replace the right spot cooler duct.

Arrange gauge set manifold hoses and tachometer leads to allow hood to be lowered, then close hood.

Place motor-driven psychrometer Tool C-3704 at cowl inlet opening. Distilled water should be used with this meter to prevent drying out and hardening the wet sock.

Place thermometer Tool C-3623 fully into center outlet grille opening. The left outlet should be fully extended and directed towards rear of vehicle.

Start the engine, open the windows, push the "Hi-Auto" button, open all grille outlets and set engine idle at 1300 R.P.M. **When testing the front unit of a dual system, leave rear unit blower turned off.**

Operate the air-conditioning system until a stabilized condition on the gauges and thermometers has been established. One of the most important steps in making the over-all performance test is that the en-

SINGLE UNIT																																					
INLET AIR WET BULB TEMPERATURE																																					
55	56	57	58	59	60	61	62	63	64	65	66	67	68	69	70	71	72	73	74	75	76	77	78	79	80	81	82	83	84	85	86	87	88	89	90		
41	42	43	44	45	46	47	48	49	50	50	50	51	51	52	52	53	53	53	54	54	55	56	57	58	59	59	60	62	64	66	67	68	69	70	71		
DISCHARGE AIR DRY BULB TEMPERATURE																																					

INLET AIR DRY BULB TEMPERATURE MUST BE BETWEEN 75° AND 110°F

NK1342 A

**Fig. 19—Performance Temperature Chart—Single Unit**

gine must be operated at the RPM as indicated for approximately five minutes to allow all the underhood components of the system to reach their operating temperature.

**Partially** close the needle valve, located below the discharge pressure gauge, to minimize oscillation of the pointer. Do not close the needle valve completely since this would prevent the discharge pressure gauge from registering pressure.

This test should be performed with the discharge pressure from 190 to 210 psi. The 190 to 210 pound pressure is for **test purposes only**. To increase pressure restrict the air flow across the condenser using cardboard, paper, etc. to decrease pressure, increase

air flow across condenser with external floor fans.

Observe and record both the "Inlet Dry Bulb Temperature" and "Inlet Wet Bulb Temperature" as registered on the psychrometer.

Observe and record "Discharge Air Temperature" registered by thermometer at right hand grille outlet.

From the "Performance Temperature Chart," (Fig. 19), determine the maximum allowable discharge air temperature for the prevailing "Dry" and "Wet" bulb temperatures recorded. If the vehicle's discharge air temperature is at or below the temperature given on the Performance Chart, the air-conditioning is delivering its cooling capacity.