

**PARTS INDICATED  
BY NAME ONLY - ORDER  
BY DESCRIPTION**

19a0308G

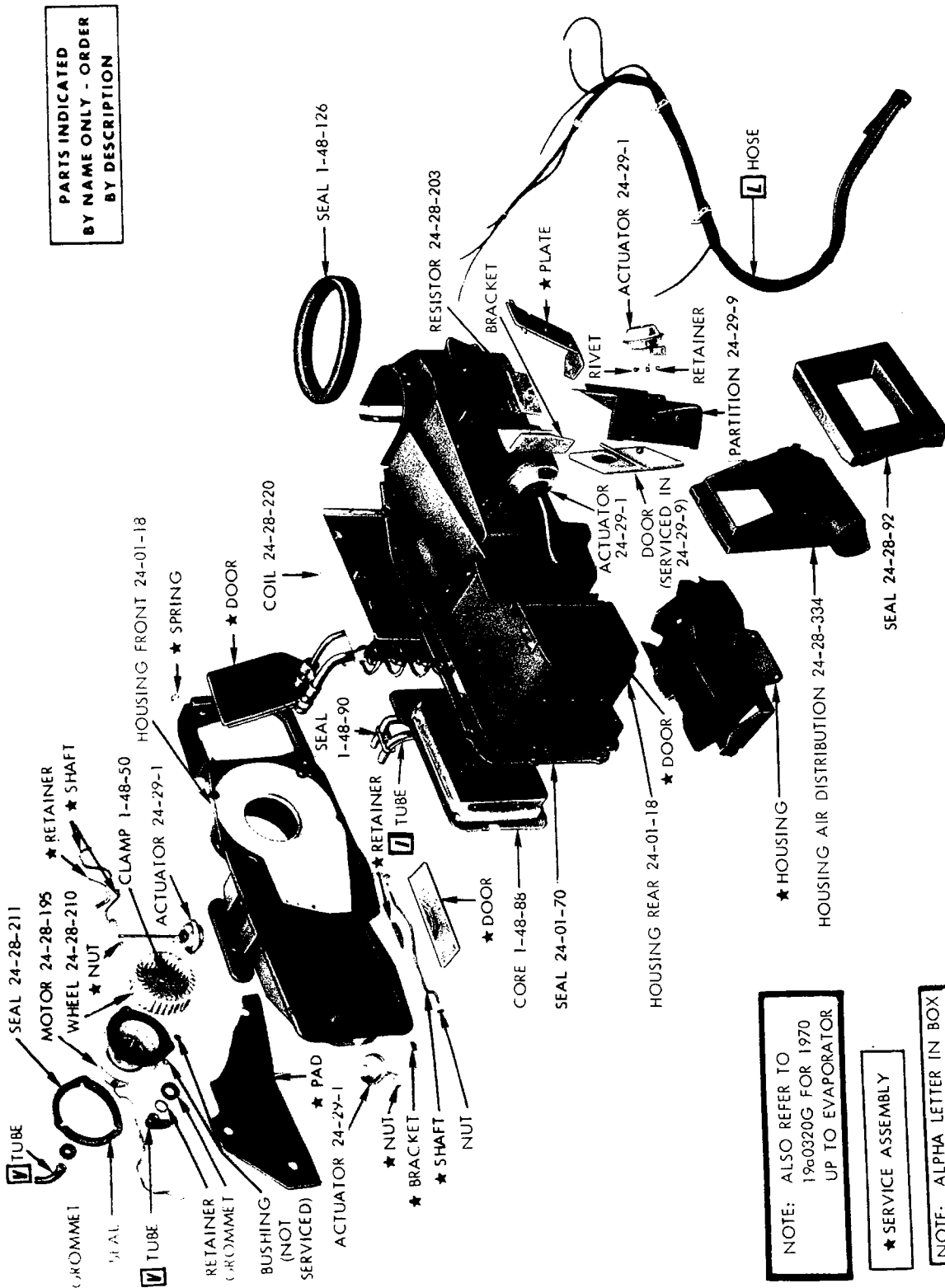

PARTS INDICATED BY NAME ONLY - ORDER BY DESCRIPTION

NOTE: ALSO REFER TO 1960320G FOR 1970 UP TO EVAPORATOR.

★ SERVICE ASSEMBLY

NOTE: ALPHA LETTER IN BOX REFER TO HOSE CHART

19a2953 A

AIR CONDITIONING EVAPORATOR - BARRACUDA AND CHALLENGER (1970-71), SATELLITE AND CORONET (1971)

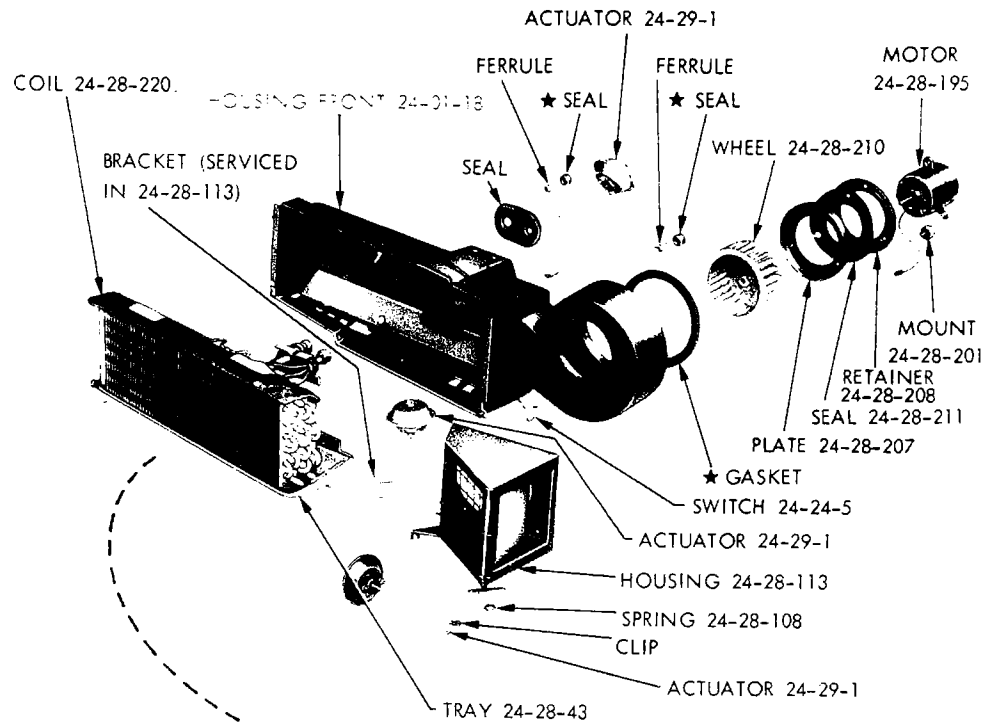

★ NOT SERVICED

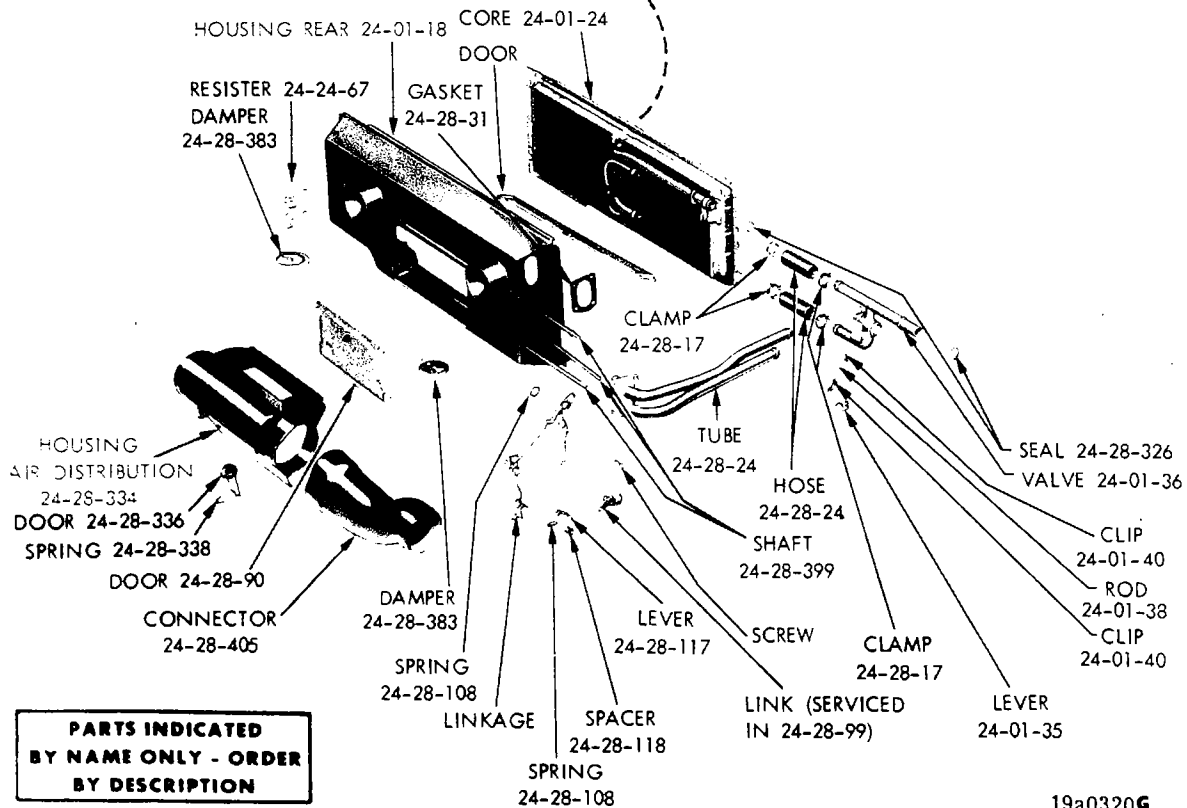

**PARTS INDICATED  
 BY NAME ONLY - ORDER  
 BY DESCRIPTION**

19a0320G

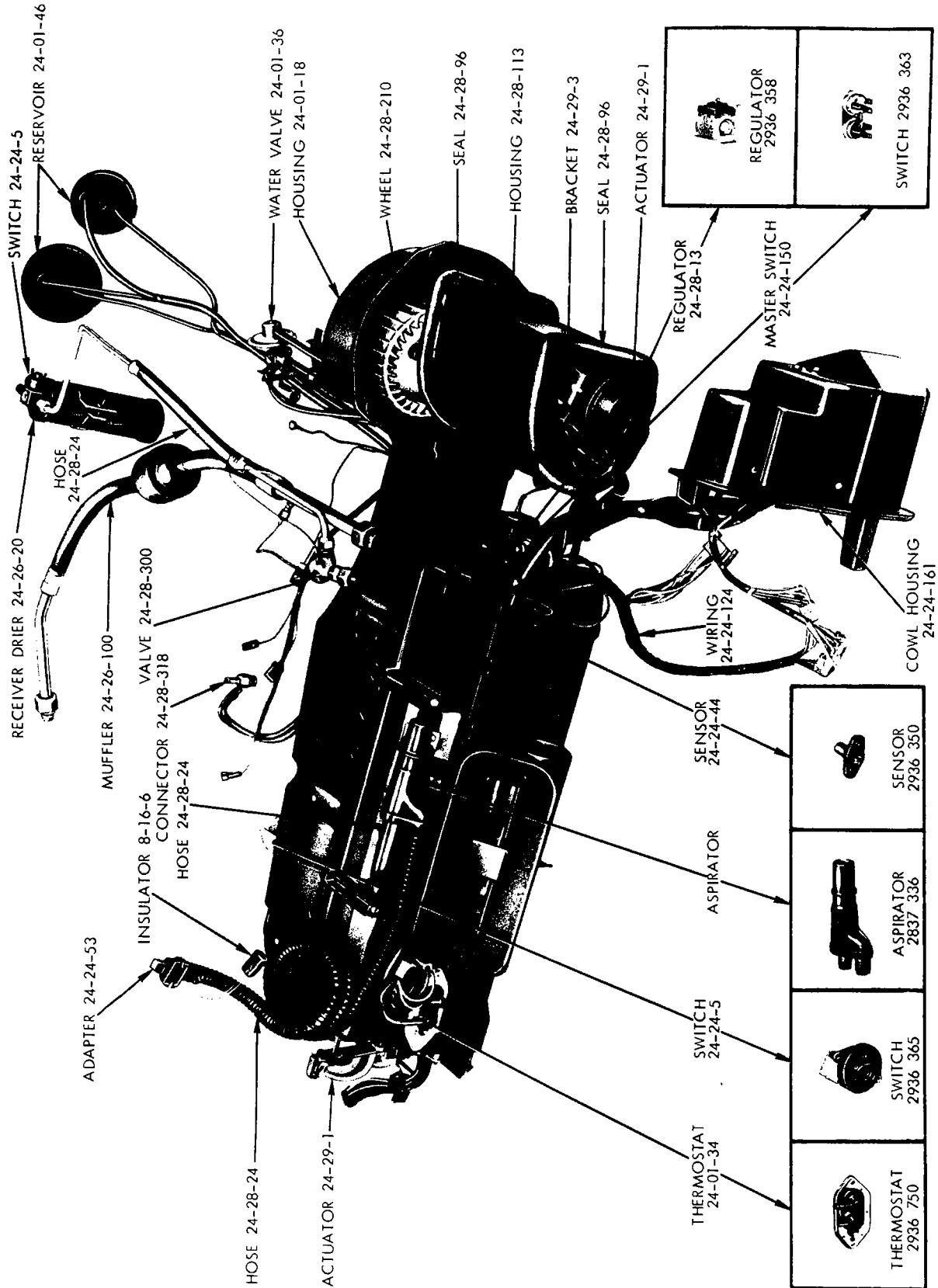

19a2708 A

AIR CONDITIONING SYSTEM - PLYMOUTH, DODGE, CHRYSLER AND IMPERIAL WITH AUTOMATIC TEMPERATURE CONTROL

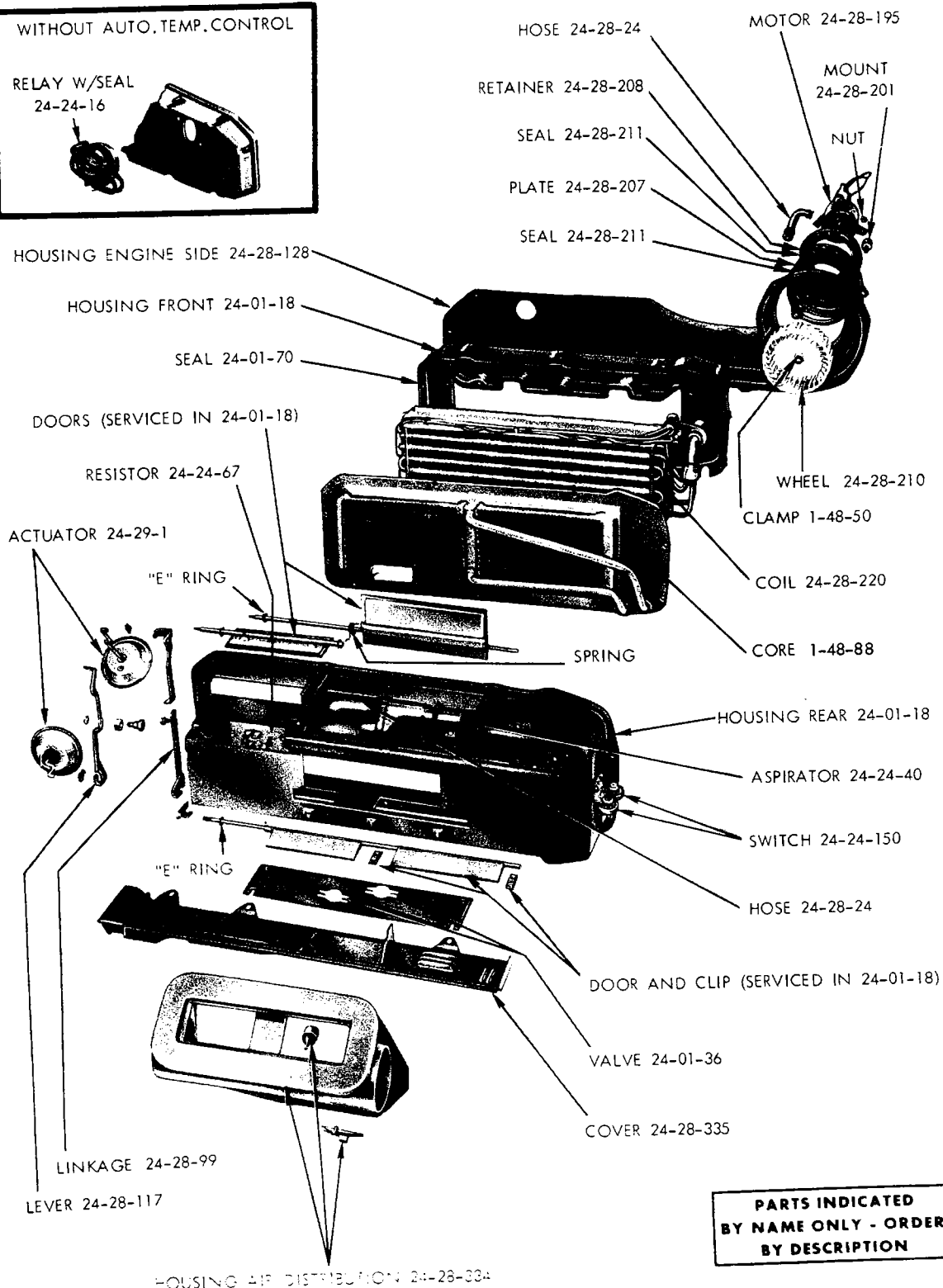
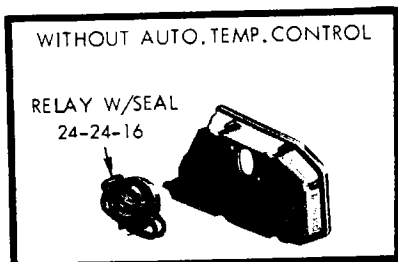

PARTS INDICATED  
BY NAME ONLY - ORDER  
BY DESCRIPTION



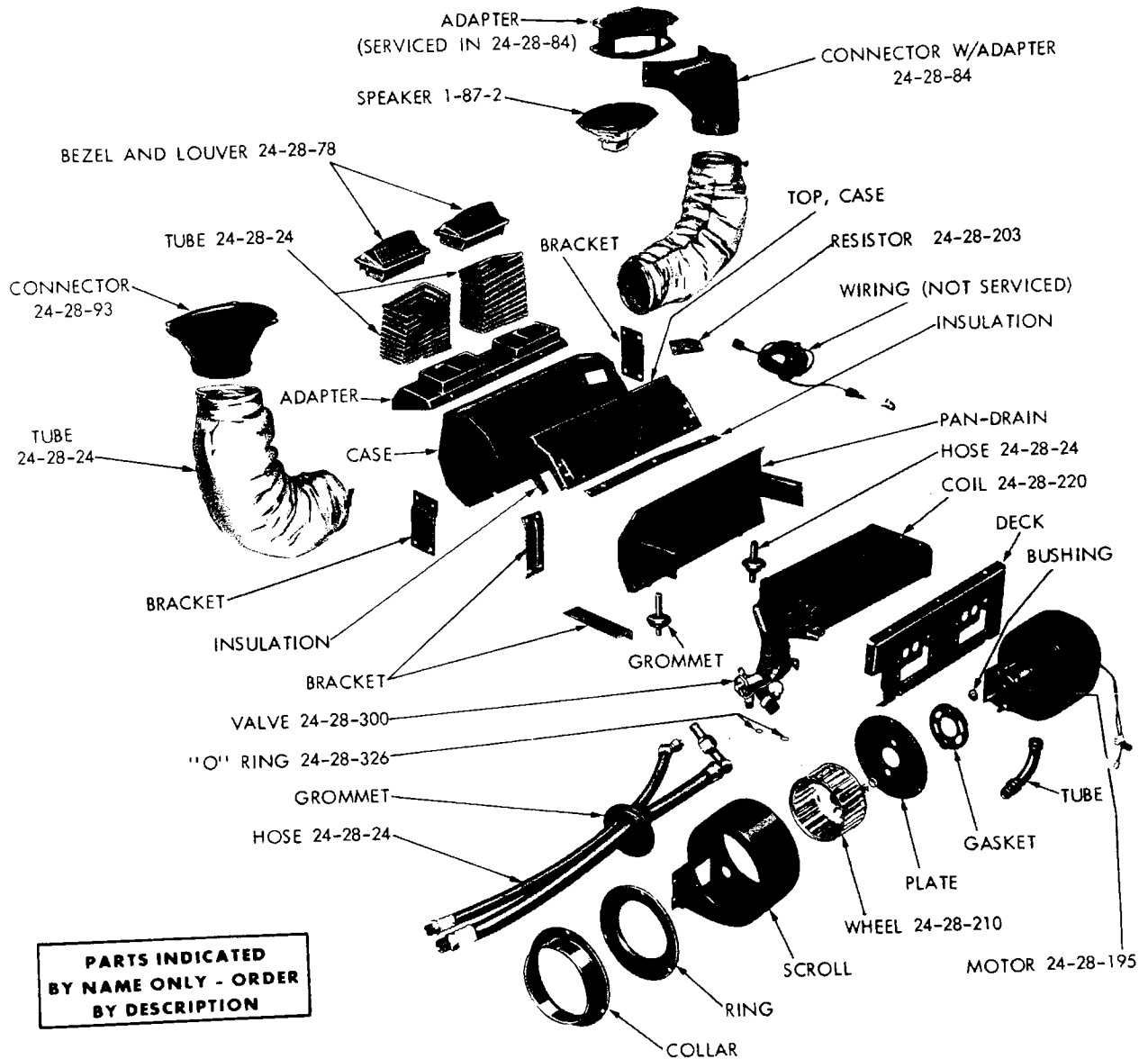

19x9975 C



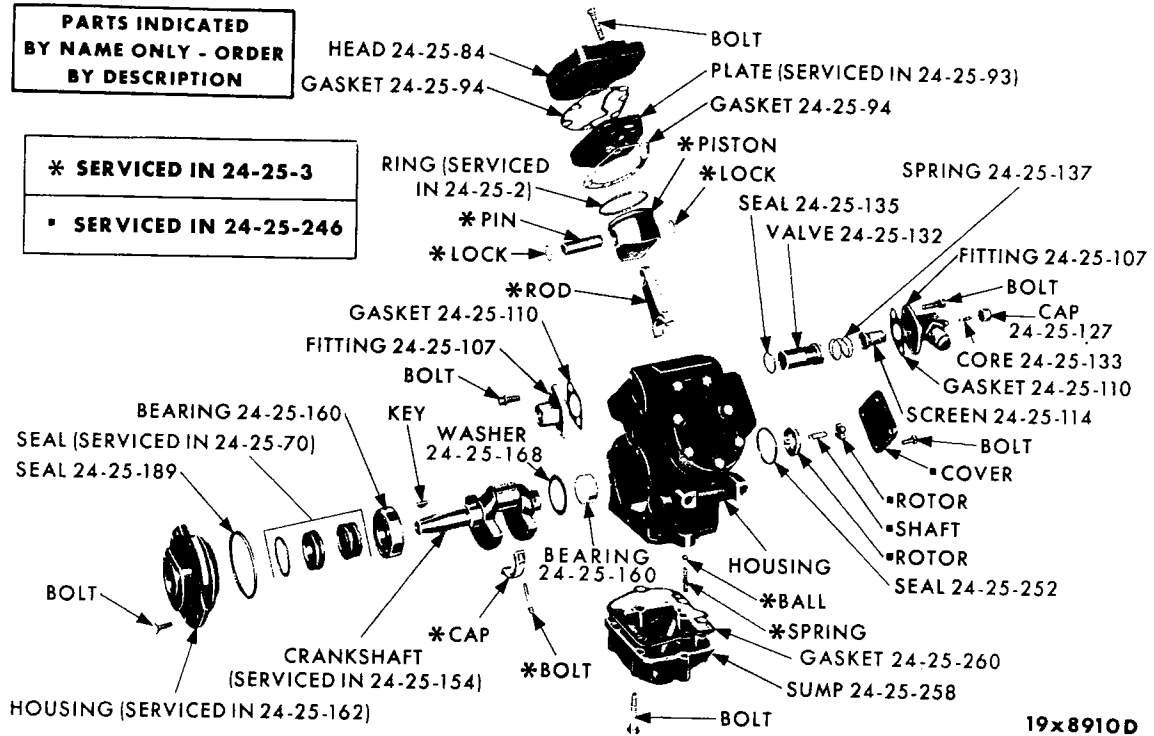

AIR CONDITIONING COMPRESSOR

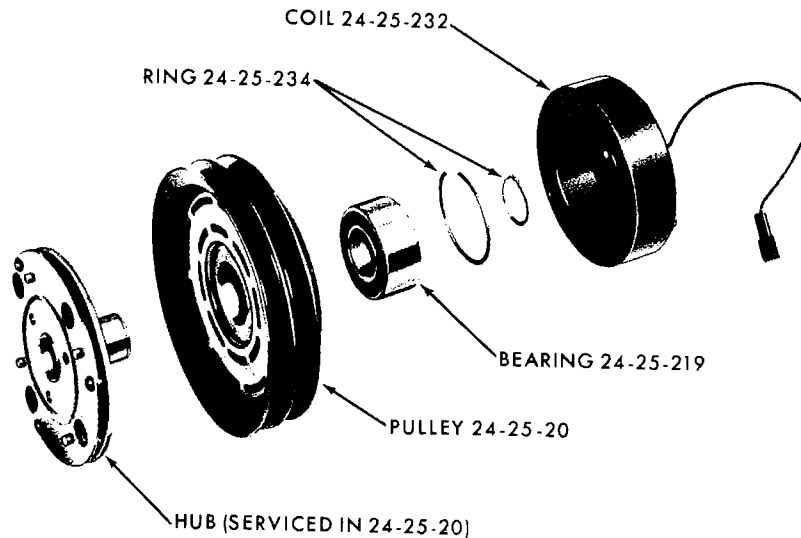

**19x9359**

COMPRESSOR CLUTCH

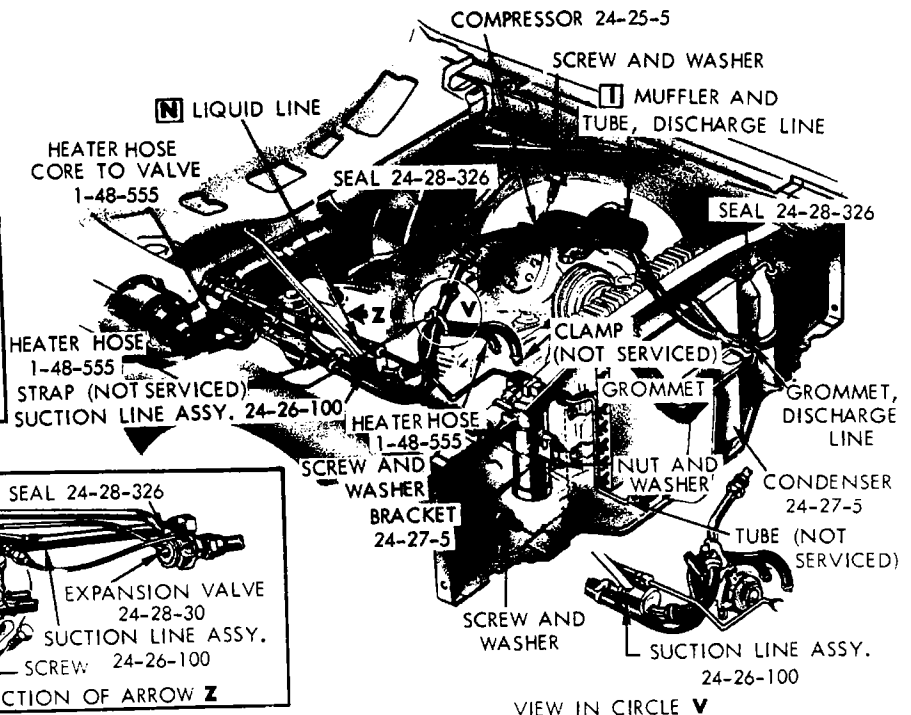
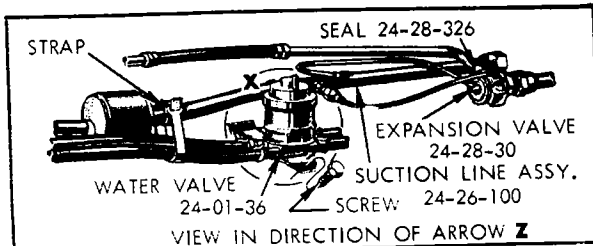
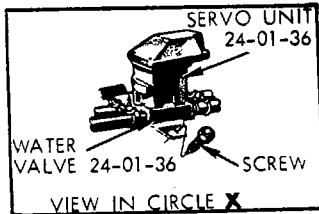
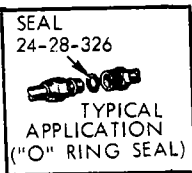
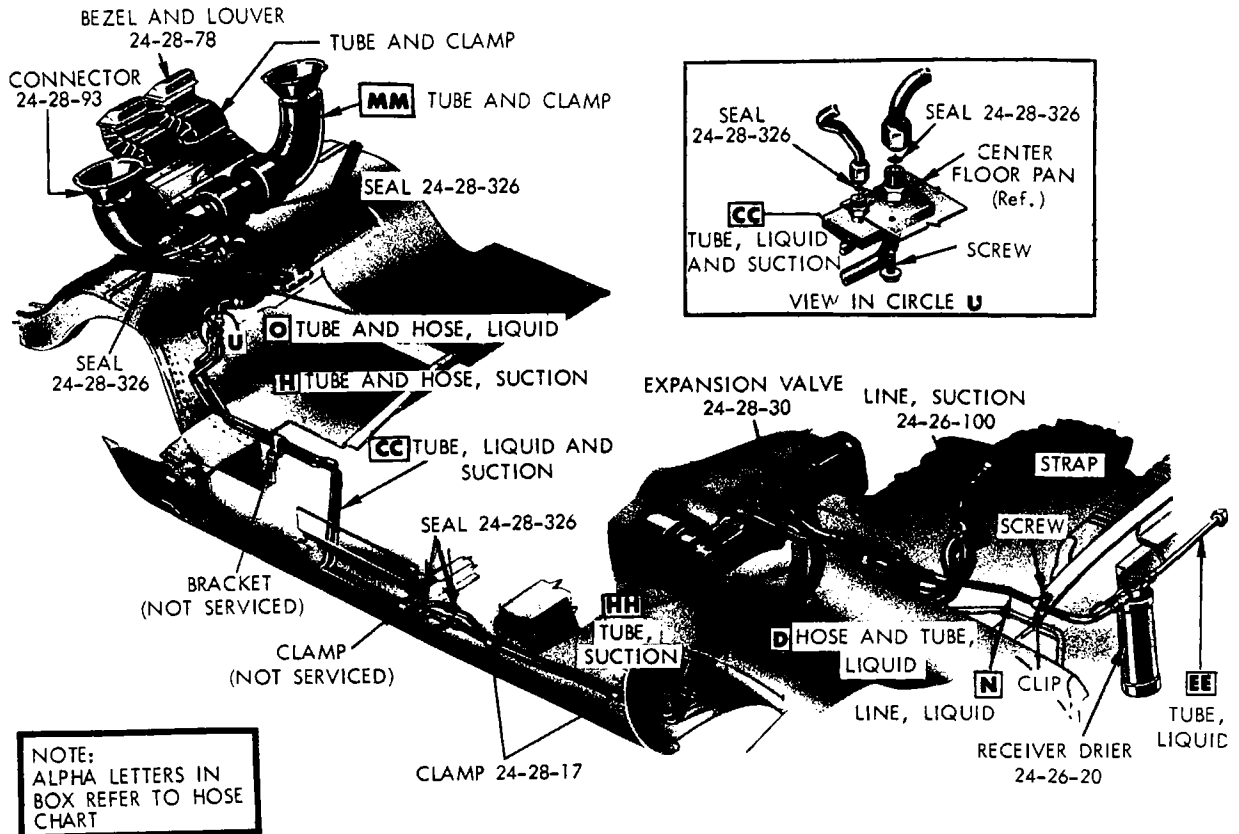

ROUTING FOR LEECE NEVILLE ALTERNATOR 19a3445

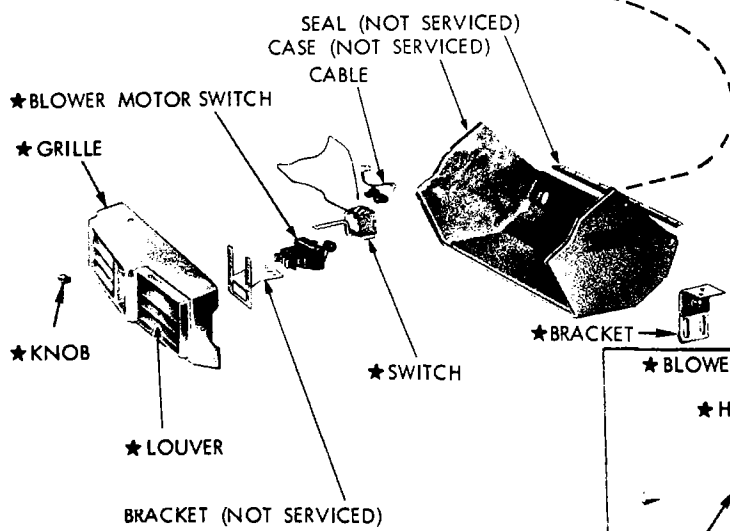
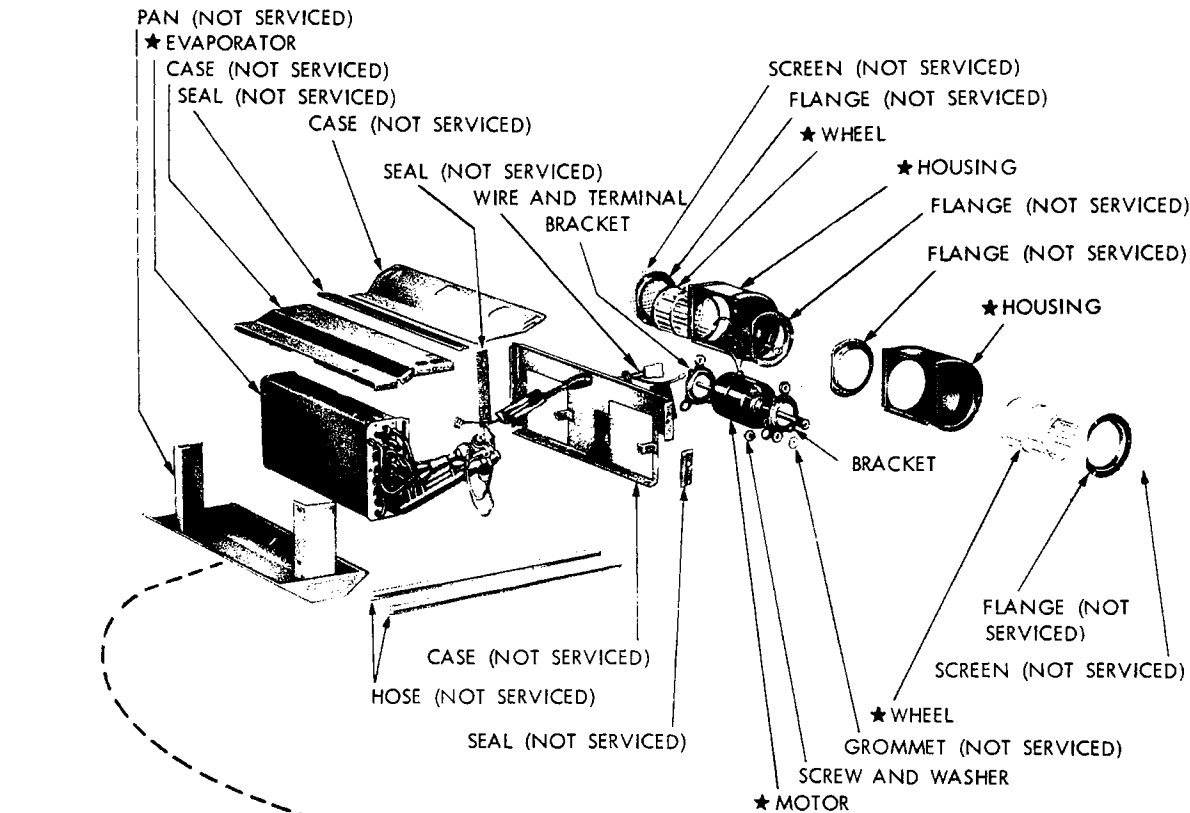

★ PARTS SERVICED IN PACKAGE SECTION

PARTS INDICATED BY NAME ONLY - ORDER BY DESCRIPTION

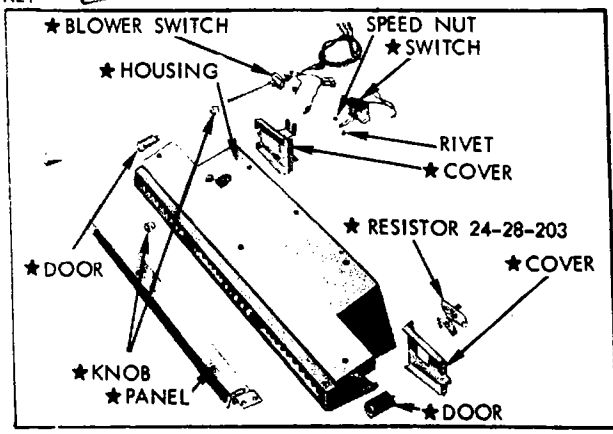



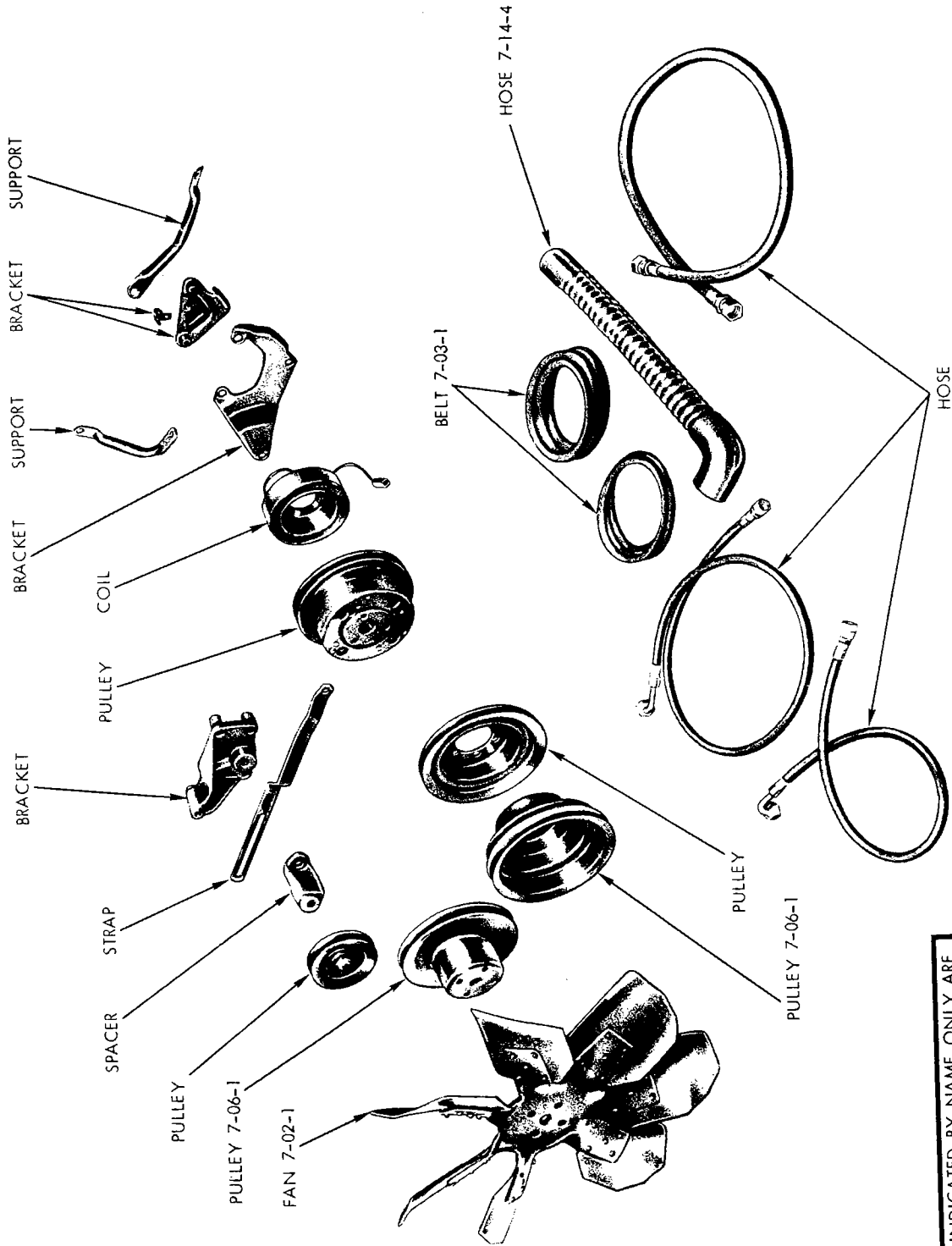









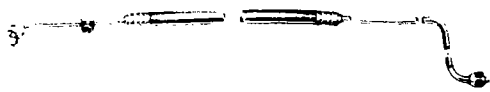

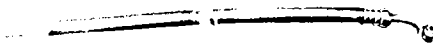

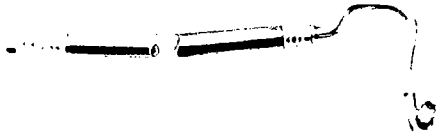
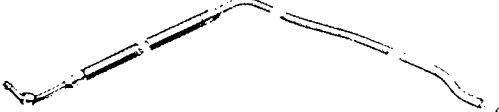

19a0345 C

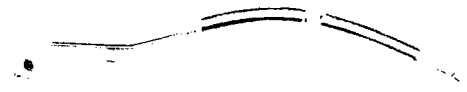

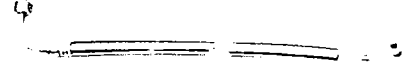
19a3261

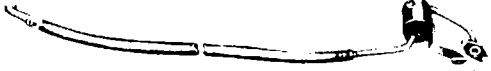
PARTS INDICATED BY NAME ONLY ARE LISTED IN THE PACKAGE SECTION WITH MODEL APPLICATION











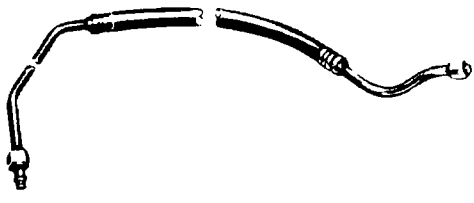

AIR CONDITIONING ADAPTER PACKAGE (TYPICAL OF MODEL "E" AND "F")

A		M	
B		N	
C		O	
D		P	
E		Q	
F		R	
G		S	
H		T	
I		U	
J			
K			
L			

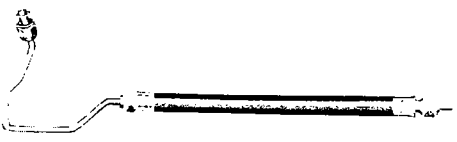
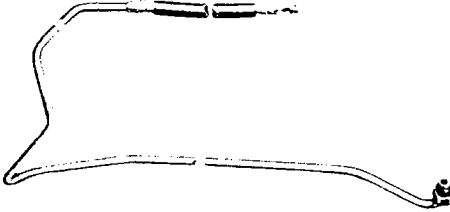
19aL2936

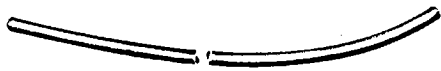
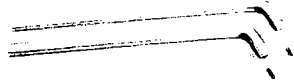
## AIR CONDITIONING HOSE CHART

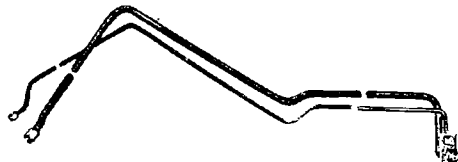
TYPE	LOCATION	MODEL APPLICATION	PART NUMBER	
A	Hose, w/Connector, Vacuum	V, L (1970)	2820 818	
	Hose, w/Connector, Vacuum	V, L (1971)	3441 896	
	Hose, Vacuum Eng. to Vacuum Resvr.	V, L (1971)	3441 897	
	Hose and Connector, Vacuum	B, J	2884 720	
		R, W	2884 036	
	Hose, w/Connector, Vacuum	R, W (1970)	3441 415	
	Hose, w/Connector, Vacuum	R, W (1971)	3431 165	
	Hose, w/Connector, Vacuum	P, D, C (1970)	3441 144	
	Main Harness, w/A. T. C.	P, D, C, Y (1970)	3441 143	
	Hose, Main Harness, Vacuum, w/A. T. C.	C, Y (1971)	3441 543	
	Hose, w/Bracket, Control Vacuum, w/A. T. C.	P, D, C, Y	2936 577	
	Hose, Vacuum Supply, Eng. Compartment, w/A. T. C.	P, D, C, Y	2837 985	
	Hose and Connector, A/Cond. & Htr., Vacuum	P, D, C, Y (1971)	3441 558	
	B	Tube, Defroster	Rt. V, L	2837 096
			Lt. V, L	2837 097
		R, W	2837 730	
Tube, Spot Cooler Flex		Rt. R, W	2837 644	
		Lt. R, W	2837 645	
		Rt. P, D, C, Y	3420 900	
Tube, A/Cond. or Htr. Spot Cooler Rt. Duct (Flex)		P, D, C, Y	2521 385	
C	Hose, In Car Sensor to Aspirator	C, Y	2936 050	
	Tube, Aspirator to Unit	C, Y	2936 370	
D	Hose and Tube, Under Body Liquid	Y	2936 562	
	Hose, A/Cond. Roof Unit Frt. U/Body Liquid	P, D, C (1971)	3441 803	
E	Hose, Roof Unit Rear Suction	P, D, C	2936 732	
	Hose, Roof Unit Rear Suction	P, D, C (1971)	3441 819	
F	Hose, Roof Unit Front Suction	P, D, C	2936 889	
	Hose, Roof Unit Front Suction	P, D, C (1971)	3441 804	
G	Hose and Tube, Suction, w/318, 340 Eng.	V, L	2936 805	
H	Tube and Hose, Rr. A/Cond., Rr. Unit Suction	Y	2936 570	
I	Line, Discharge	P, D, C	2936 498	
	Line, Discharge, w/383, 440 Eng.	P, D, C (1971)	3441 837	
	Line, Discharge, w/318, 360 Eng.	P, D, C (1971)	#3441 992	
J	Line, Discharge	B, J	3441 524	
	Line, Discharge	Y	2936 742	
	Line, Discharge	Y (1971)	3441 525	
K	Line, Suction, Dual Unit, w/Leece Alternator	B, J, P, D, C	3441 019	
	Line, Suction, Single Unit, w/Leece Alternator	P, D, C	3441 018	
L	Line, Suction, w/225 Eng.	P, D	2936 574	
M	Hose and Tube, Suction Unit to Suction Muffler, w/318 Eng.	R, W	2936 792	
N	Line, Liquid, Rec. Drier to Exp. Valve	P, D, C	3441 016	
	Line, Liquid, Rec. Drier to Exp. Valve	P, D, C (1971)	3441 839	
	Line, Liquid, Dual Unit	P, D, C	3441 017	
	Line, Liquid, Dual Unit	P, D, C (1971)	3441 840	
	Line, Liquid, Dual Unit	Y	3441 711	
O	Tube and Hose, Rr. A/Cond., Rr. Unit Liquid	Y	2936 569	
P	Tube, Liquid, Condensor to Rec. Drier	R, W	2936 790	
Q	Hose and Tube, Discharge Muffler to Condensor, w/318 Eng.	R, W	2936 797	
R	Hose and Tube, Rec. Drier to Exp. Valve	R, W	2936 791	
S	Hose, Roof Unit Forward Liquid	P, D, C	2936 888	
T	Hose, Roof Unit Rear Liquid	P, D, C	2936 730	
	Hose, Roof Unit Rear Liquid	P, D, C (1971)	3441 820	

V		DD	
W		EE	
X		FF	
Y		GG	
Z		HH	
AA		II	
BB		JJ	
CC		KK	

19aL2937B

## AIR CONDITIONING HOSE CHART

TYPE	LOCATION	MODEL APPLICATION	PART NUMBER
V	Hose and Tube, Discharge	V, L	2936 789
W	Tube, Liquid, Condensor to Rec. Drier	V, L (1970-71)	3441 893
X	Extension, Vacuum Hose	P, D, C, Y	3431 055
Y	Hose, Vacuum Recirculating, w/A. T. C.	P, D, C, Y	2936 749
	Hose, Vacuum Recirculating, w/A. T. C.	C, Y (1971)	3441 396
Z	Hose and Tube, Discharge Muffler to Condensor, w/225 Eng.	R, W	2936 796
AA	Hose, Blower Motor Cooling	V, L	2521 478
	Tube, Blower Motor Cooling	B, J, R, W	2936 925
	Tube, Drain	B, J, R, W	2936 926
BB	Tube, Water Inlet and Outlet	R, W	2607 040
CC	Tube, Underbody, Liquid and Suction	Y	2936 564
DD	Line, Liquid, Valve to Rec. Drier	B, J	3441 091
EE	Tube, Liquid, Rec. Drier to Condensor		
	UP TO May, 1971	B, J, R, W	3441 090
	AFTER May, 1971	B, J	3441 966
	AFTER May, 1971	R, W	3441 966
	Tube, Liquid, Rec. Drier to Condensor		
	UP TO Nov. 1970	R, W	3441 847
	AFTER Nov. 1970	R, W	3441 967
	Tube, Liquid, Rec. Drier to Condensor	Y	3441 533
FF	Hose, Water Valve to Core	V, L	2958 932
	Hose, Rr. Evaporator Unit Drain	Y	2485 820
GG	Tube, Discharge	R, W	3441 104
HH	Tube, Underbody Suction	Y	2936 563
II	Hose, Heater, Engine to Valve	V, L, B, J, P, D, C, Y	2936 388
	Hose, Drain Roof Unit	P, D, C	2097 131
JJ	Tube, Liquid, Rec. Drier to Exp. Valve	V, L	3441 798
	Tube, Liquid, w/Leece Neville Alternator	R, W (1971)	3441 847
	Tube, Liquid, Rec. Drier to Exp. Valve, w/Leece Neville Alternator	R, W (1971)	3441 846
	Line, Liquid, Rec. Drier to Exp. Valve, UP TO June 1, 1971	B, J, R, W (1971)	3441 739
	Line, Liquid, Rec. Drier to Exp. Valve, AFTER June 1, 1971	B, J, R, W (1971)	#3502 110
	Line, Liquid, w/Single Unit and A. T. C.	Y	2936 291
	Line, Liquid, w/Single Unit and A. T. C.	Y (1971)	3441 534
KK	Line, Liquid, Condensor to Rec. Drier	R, W	3441 424

NOTE: For Muffler and Tubes, see Part Type Code 24-26-100.



CODE	PART NAME	ENG. TYPE OR CU.IN.	V	B	L	R	W	P	D	C	C	C	Y	PART NUMBER
			1-2	1-2	1-2	1-2	1-2	1-2	1-2	1	2	3	1	
<b>24-01-0 AIR CONDITIONING</b>														
NOTE: All parts identified as model "E" or model "F" in part name column indicate usage on Field Installed Units only.														
Service parts for Field Installed Units are listed in the Parts Package Section of this catalog.														
24-01-1	BASIC PACKAGE	Model "E"	1	1	1	—	—	—	—	—	—	—	—	2027 816
		Model "F"	1	1	1	1	1	1	1	1	1	1	1	2027 820
	ADAPTER PACKAGE		1	1	1	1	1	1	1	—	—	—	—	2027 817
	All w/198 or 225 Cu. In. Eng.		1	1	1	1	1	1	1	1	1	1	—	2027 818
	w/318 or 340 Cu. In. Eng.		1	1	1	1	1	1	1	1	1	1	1	2027 819
	w/383 or 440 Cu. In. Eng.		1	1	1	1	1	1	1	1	1	1	1	2027 821
	PACKAGE, Spot Cooler Air Duct	ALL	1	1	1	1	1	1	1	1	1	1	1	2027 787
	CONDENSER PACKAGE	ALL	1	1	1	—	—	—	—	—	—	—	—	2027 814
		ALL	—	—	—	1	1	1	1	1	1	1	1	
	FACTORY INSTALLED													
	UNIT, A/Cond., and Htr., Htr. Half Complete		1	—	1	—	—	—	—	—	—	—	—	3441 200
	UNIT, A/Cond., and Htr. Evap. w/Vacuum Harness	70	1	—	1	—	—	—	—	—	—	—	—	2936 892
		71	1	—	1	—	—	—	—	—	—	—	—	3441 925
		70	—	1	—	—	—	—	—	—	—	—	—	2936 927
	Up to March, 1971	71	—	1	—	—	—	—	—	—	—	—	—	3441 928
	After March, 1971	71	—	1	—	—	—	—	—	—	—	—	—	= 3441 986
		70	—	—	—	1	1	—	—	—	—	—	—	3441 433
	Up to March 1971		—	—	—	1	1	—	—	—	—	—	—	3441 930
	After March 1971		—	—	—	1	1	—	—	—	—	—	—	= 3441 991
	Pass. Side w/Out A.T.C.	71	—	—	—	—	—	1	1	1	1	1	1	3441 554
	w/A.T.C.	70	—	—	—	—	—	1	1	1	1	1	1	3441 618
	Passenger Side w/A.T.C. w/Harness	71	—	—	—	—	—	—	1	1	1	1	1	3441 542
	Passenger Side w/Out A.T.C.	70	—	—	—	—	—	1	1	1	1	1	1	3441 616
	Roof Unit, Sta. Wgn. Only		—	—	—	—	—	—	—	—	—	—	—	2936 414
	Roof Unit, Sta. Wgn. Only		—	—	—	—	—	—	—	—	—	—	1	2936 140
	Roof Unit		—	—	—	—	—	—	—	—	—	—	—	2607 043
24-01-3	SPACER, Mtg. at Dash	70	—	—	—	5	5	—	—	—	—	—	—	2837 113
24-01-10	RETAINER, A/Cond. and Htr. Carpet	70	—	—	—	1	1	—	—	—	—	—	—	3441 096
24-01-16	BRACKET, Water Valve Mtg.		—	1	—	1	1	—	—	—	—	—	—	
24-1-18	HOUSINGS, A/C and Htr.		1	—	1	—	—	—	—	—	—	—	—	2521 551
	Front	70	—	1	—	1	1	—	—	—	—	—	—	2936 934
	Up to March, 1971		—	1	—	1	1	—	—	—	—	—	—	= 3441 566
	After March, 1971		—	1	—	1	1	—	—	—	—	—	—	= 3441 988
	Less Core		—	1	—	1	1	—	—	—	—	—	—	= 3502 210
	Housing w/Scroll w/Insulator	70	—	—	—	1	1	—	—	—	—	—	—	2923 936
	Complete		—	—	—	—	—	1	1	1	1	1	1	3441 171
	REAR		1	—	1	—	—	—	—	—	—	—	—	2521 563
	Complete	70	—	1	—	1	1	—	—	—	—	—	—	2936 958
	Up to March, 1971	70	—	1	—	1	1	—	—	—	—	—	—	3441 564
	After March 1971		—	1	—	1	1	—	—	—	—	—	—	3441 927
	Less Coil		—	1	—	1	1	—	—	—	—	—	—	3441 989
	w/End Plates	70	—	—	—	1	1	—	—	—	—	—	—	= 3502 211
	w/o A.T.C.	70	—	—	—	—	—	1	1	1	1	1	—	2837 968
	w/A.T.C.	70	—	—	—	—	—	1	1	1	1	1	1	2936 239
	Complete w/A.T.C.	70	—	—	—	—	—	1	1	1	1	1	1	2936 355
	Complete w/o A.T.C.	70	—	—	—	—	—	—	1	1	1	1	1	3441 163
	Complete w/A.T.C.	71	—	—	—	—	—	—	—	1	1	1	1	3441 162
	w/o A.T.C.	71	—	—	—	—	—	—	—	1	1	1	1	3441 550
	Complete w/A.T.C.	71	—	—	—	—	—	—	—	1	1	1	1	3441 556
	w/o A.T.C.	71	—	—	—	—	—	—	—	1	1	1	1	3420 787
24-01-24	CORE, A/Cond. and Htr. or ATC		—	—	—	—	—	—	1	1	1	1	1	2485 134
	NOTE: For further information see P.T.C. 1-48-88.													
24-01-26	SEAL, Htr. Core Tube to Dash		2	—	2	—	—	—	—	—	—	—	—	= 3441 863
	Up to Feb. 1971		2	—	2	—	—	—	—	—	—	—	—	= 3502 080
	After Feb. 1971													

CARLINES

J - Challenger  
B - Barracuda

V - Valiant  
L - Dart

R - Belvedere - Satellite  
W - Coronet - Charger

P - Plymouth  
D - Dodge

C - Chrysler  
Y - Imperial

AR Indicates use as required.

# Indicates parts not listed in any previous parts book.

Numerals in parentheses ( ) refer to notes.

\* Indicates change or addition.

Printed in U.S.A.  
January 1972

CODE	PART NAME	ENG. TYPE OR CU. IN.	V	B	L	R	W	P	D	C	C	C	Y	PART NUMBER
			1-2	1-2	1-2	1-2	1-2	1-2	1-2	1	2	3	1	
<b>24-01-0 AIR CONDITIONING Cont'd.</b>														
24-01-31	SLEEVE, Heater Hose		1		1									2127 280
	Valve to Pump Hose			1										2127 280
	Core to Pump Hose					1	1							2127 280
	Valve to Pump							1	1	1				2127 280
24-01-33	RETAINER, Roof Unit Louver to Adapter							4	4	4	4	4		1689 670
24-01-34	THERMOSTAT, Water Valve, w/ A.T.C.	70						1	1	1	1	1	1	2936 750
24-01-35	LEVER, A/Cond. and Htr. Door Shaft Water Valve Link					1	1							2521 243
24-01-36	VALVE, Water, w. Bracket		1		1									3441 045
	Water	71	1		1									3579 173
	Water			1										3441 034
	Water	71		1										3441 884
	Water	70				1	1							2521 240
	Water	71				1	1							3441 885
	Water w/o A.T.C.	70						1	1	1	1	1	1	2936 490
	Water w/o A.T.C.	71						1	1	1	1	1	1	3441 562
	Water, w A.T.C.	70						1	1	1	1	1	1	2936 495
	Temp. Control, w Bracket	70				1	1							3441 414
	Vacuum Check, Four Port							1	1	1	1	1	1	2820 880
	Vacuum Check, Two Post Tee			1										3441 609
24-01-38	ROD, Water Valve Control	70				1	1							2521 246
24-01-39	SEAL, Temp. Control Valve at Dash	70				1	1							2607 025
24-01-40	CLIP, Water Valve Control Rod Mtg. at Shaft	70						1	1					2465 560
	Spotcooler Conn. Mtg.	70						1	1					2521 729
	Spotcooler Tube Mtg.	70						1	1					2521 729
	Spotcooler Duct to Hsg.	Rt. 70						1	1					2521 729
24-01-41	RETAINER, Check Valve and Vacuum Hose, Use w/A.T.C. Only	70							1	1	1	1	1	2936 559
	Use w A.T.C. Only	71								1	1	1	1	3441 813
24-01-43	PLATE W Weld Screw, A/Cond. and Htr. Control	70	1											2864 592
		70			1									2864 593
	NOTE: For Further Information See P.T.C. 1-48-867													
24-01-45	POTENTIOMETER and CABLE	70							1					2864 628
		70								1	1	1	1	2884 533
	A.T.C.	71								1	1	1	1	3431 209
	w Thumbwheel and Mtg. Brkt.	70							1					2884 357
24-01-46	RESERVOIR, Slave Circuit Vacuum	70	225						1	1				3441 319
		71							1	1	1	1	1	3420 851
	Except 225								1	1	1	1	1	3420 851
		71							1	1				3441 532
	Control Circuit Vacuum	70							1	1	1	1	1	2837 314
	A, C and Htr. Valve Vacuum		1		1									2837 314
	Vacuum Control	70				1	1							3441 416
	Vacuum Control	71				1	1							3441 532
	Vacuum W/Trailer Tow	71						1	1	1	1	1		3441 955
24-01-52	INSULATOR, Potentiometer and Cable	70								1	1	1	1	2770 859
24-01-65	CABLE, Temp. Control, 71" Long	70		1										3431 215
	74" Long	70		1										3431 339
	71" Long	71		1										= 3431 459
	w Clamp	70	1		1									2808 966
	w Insulator	70	1		1									2808 967
	Clip Self Adjusting Cable			1										= 6028 590
	Clip, Cable Retaining			1										= 2884 656
	NOTE: For Further Information See P.T.C. 1-48-941													
24-01-66	RETAINER, Temp. Control Cable	Bottom	1		1									2197 678
		Top	1		1									2197 678
		To Rod	1		1									2197 678

CARLINES

J - Challenger  
B - BarracudaV - Valiant  
L - DartR - Belvedere - Satellite  
W - Coronet - ChargerP - Plymouth  
D - DodgeC - Chrysler  
Y - Imperial

# Indicates use as required.

\* Indicates parts not listed in any previous parts book.

Numerals in parentheses refer to notes.

★ Indicates change or addition.

Printed in U.S.A.  
January 1972

CODE	PART NAME	ENG. TYPE OR CU.IN.	V	B	L	R	W	P	D	C	C	C	Y	PART NUMBER
			1-2	1-2	1-2	1-2	1-2	1-2	1-2	1	2	3	1	
<b>24-01-0 AIR CONDITIONING Cont'd.</b>														
24-01-66	RETAINER Cont'd.													
		To Switch	1	—	1	—	—	—	—	—	—	—	—	2197 678
		Inlet Door Actuator Rod	2	—	2	—	—	—	—	—	—	—	—	2197 678
		Temp. Door Cable to Control	1	—	1	1	1	—	—	—	—	—	—	2197 678
		Thumbwheel	—	—	—	—	—	1	1	1	1	1	1	2197 678
		Temp. Control Cable	—	1	—	—	—	—	—	—	—	—	—	3431 457
24-01-70	SEALS													
		Rr. Hsg. to Dist. Hsg.	—	1	—	1	1	—	—	—	—	—	—	2936 502
		Rr. Hsg. to Frt. Hsg. At Coil	—	1	—	—	—	—	—	—	—	—	—	2936 957
		Vent Cover to Cowl Panel	—	—	—	—	—	3	3	3	3	3	—	3441 287
		Rr. Hsg. to Frt. Hsg.	—	—	—	—	—	1	1	1	1	1	1	3441 168
		Rr. Hsg. to Frt. Hsg.	—	—	—	2	2	—	—	—	—	—	—	2936 957
		Frt. Hsg. to Dash	—	—	—	—	—	1	1	1	1	1	1	2936 233
		Eng. Side to Dash Bottom Hsg.	—	—	—	—	—	1	1	1	1	1	1	3441 061
		Eng. Side Hsg. to Dash	—	—	—	—	—	1	1	1	1	1	1	3441 060
		F/Air Vent Hsg. to Cowl Side Panel	—	—	—	—	—	1	1	1	1	1	—	3441 287
24-01-87	NIPPLES													
		Htr. Hose to Pump	—	1	—	—	—	1	1	1	1	1	1	2936 757
		Htr. Hose to Eng. Up to April 1971	1	1	1	1	1	1	1	1	1	1	1	3441 020
		Htr. Hose to Eng. After April 1971	1	1	1	1	1	1	1	1	1	1	1	= 3502 123
24-01-225	SEAL, Evap. Coil, Side													
		Top	—	1	—	1	1	—	—	—	—	—	—	3441 499
		Htr. Dr. Vac. Actr.	—	1	—	1	1	—	—	—	—	—	—	3441 500

**24-24-0 CONTROLS**

24-24-5	SWITCHES													
		Blower Control	1	—	1	—	—	—	—	—	—	—	—	2864 591
		Blower	—	1	—	—	—	—	—	—	—	—	—	2884 727
		Blower 70	—	—	—	1	1	—	—	—	—	—	—	2864 821
		Blower, Rr., 3 Position 70	—	—	—	—	—	1	1	—	—	—	—	2820 455
		Blower, Rr., 3 Position	—	—	—	—	—	—	—	—	—	1	—	= 2864 499
		Sta. Wgn. Only	—	—	—	—	—	1	1	—	—	—	—	2820 455
		Blower, Rr.	—	—	—	—	—	1	—	—	—	—	—	2884 258
		Blower, Complete	—	—	—	—	—	—	1	—	—	—	—	2864 440
		Blower, Rocker	—	—	—	—	—	—	1	1	1	—	—	3431 137
		Blower A/C and Htr. Control 71	—	—	—	1	1	—	—	—	—	—	—	3441 094
		Low Pressure Cut Off 70	—	—	—	—	—	1	1	1	1	1	1	
		Low Pressure Cut Off up to Nov. 1, 1970 71	1	1	1	1	1	1	1	1	1	1	1	3441 904
		Low Pressure Cut Off After Nov. 1, 1970 71	1	1	1	1	1	1	1	1	1	1	1	= 3502 016
		Ambient, w/A.T.C. Only	—	—	—	—	—	1	1	1	1	1	1	2936 365
		A.T.C. Cold Eng. Lockout 71	—	—	—	—	—	—	—	1	1	1	1	3441 529
		NOTE: For switches not listed see P.T.C. 1-48-770												
24-24-7	HOLDER, Fuse													
		Holder, Fuse A/C Cont. Jumper 71	—	—	—	—	—	—	—	1	1	1	1	2257 679
24-24-13	RETAINER, Blower Switch Link													
		RELAY and SEAL, Vacuum Time Delay 70	—	1	—	1	1	1	1	1	1	1	—	2197 678
24-24-16	RELAY and SEAL, Vacuum Time Delay 71													
			—	—	—	—	—	1	1	1	1	1	1	2936 666
			—	—	—	—	—	—	—	—	—	—	—	3441 868
24-24-18	COVER and INSERT, A.T.C. Push Button Extension													
		Defrost 70	—	—	—	—	—	—	—	—	—	—	1	2884 460
		Hi Defrost 70	—	—	—	—	—	—	—	—	—	—	1	2884 461
24-24-30	AMPLIFIER A/C and Htr. A.T.C. Only 71													
			—	—	—	—	—	—	—	1	1	1	1	3441 553
24-24-39	CONTROL, A/Cond. and Htr., Also Use 1													
		Of 2820487	1	—	1	—	—	—	—	—	—	—	—	2884 108
		w/Rallye Inst. Panel	—	1	—	—	—	—	—	—	—	—	—	2884 700
		w/Out Rallye Inst. Panel	—	1	—	—	—	—	—	—	—	—	—	2884 701
		70	—	—	—	1	1	—	—	—	—	—	—	2932 974

CARLINES

J - Challenger  
B - Barracuda

V - Valiant  
L - Dart

R - Belvedere - Satellite  
W - Coronet - Charger

P - Plymouth  
D - Dodge

C - Chrysler  
Y - Imperial

AR Indicates use as required.

# Indicates parts not listed in any previous parts book.

Numerals in parentheses ( ) refer to notes.

★ Indicates change or addition.

Printed in U.S.A.  
January 1972

CODE	PART NAME	ENG. TYPE OR CU.IN.	V	B	L	R	W	P	D	C	C	C	Y	PART NUMBER
			1-2	1-2	1-2	1-2	1-2	1-2	1-2	1	2	3	1	
<b>24-24-0 CONTROLS Cont'd.</b>														
24-24-39	CONTROL Cont'd.													
		Up to April 1971	—	—	—	1	1	—	—	—	—	—	—	3431 127
		After April 1971	—	—	—	1	1	—	—	—	—	—	—	= 3431 572
		NOTE: For Further Information See P.T.C. 1-48-4												
24-24-40	ASPIRATOR, w/A.T.C.		—	—	—	—	—	—	1	1	1	1	1	2837 336
24-24-41	TUBE, A/C and Htr. Aspirator to Unit	70	—	—	—	—	—	—	1	1	1	1	1	2936 370
24-24-44	SENSOR, w/A.T.C.	70	—	—	—	—	—	—	1	1	1	1	1	2936 350
	Ambient W/A.T.C.	After Sept 1971	—	—	—	—	—	—	—	1	1	1	1	3441 935
		Up To Sept. 1971	—	—	—	—	—	—	—	1	1	1	1	= 3441 790
24-24-45	GASKET, Ambient Sensor Sealing		—	—	—	—	—	—	1	1	1	1	1	2837 374
24-24-53	ADAPTOR, In Car Sensor, w/A.T.C.	70	—	—	—	—	—	—	1	—	—	—	—	2936 479
		70	—	—	—	—	—	—	—	1	—	—	—	2936 480
		70	—	—	—	—	—	—	—	1	1	1	1	2936 481
		71	—	—	—	—	—	—	—	1	1	1	—	3441 340
		71	—	—	—	—	—	—	—	—	—	—	1	3441 732
24-24-55	INSULATOR, In Car Sensor Term.	70	—	—	—	—	—	—	1	1	1	1	1	2770 859
	A.T.C.	71	—	—	—	—	—	—	—	1	1	1	1	3513 683
24-24-59	REGULATOR, Control Vacuum	70	—	—	—	—	—	—	1	—	—	—	—	2884 333
		NOTE: For Further Information See P.T.C. 1-48-374												
24-24-67	RESISTOR, Blower Motor	70	—	—	—	1	1	—	—	—	—	—	—	2936 278
	w/out A.T.C.		—	—	—	—	—	—	1	1	1	1	—	2936 278
	w/A.T.C.		—	—	—	—	—	—	1	1	1	1	1	2936 357
		NOTE: For Further Information See P.T.C. 1-48-832												
24-24-124	WIRING, A/Cond. & Htr.													
	Inst. Pnl. V		1	—	—	—	—	—	—	—	—	—	—	2857 837
	V-L, 2D., Fast Back and L-L Swinger		1	—	1	—	—	—	—	—	—	—	—	2857 837
	L		—	—	1	—	—	—	—	—	—	—	—	2983 644
	V-S, V-H and L-M, L-H, L-L 2 D H.T., 4D.		1	—	1	—	—	—	—	—	—	—	—	2983 644
	B, J		—	1	—	—	—	—	—	—	—	—	—	2983 247
	Inst. Pnl.	70	—	—	—	1	1	—	—	—	—	—	—	2889 390
		71	—	—	—	1	1	—	—	—	—	—	—	3513 092
	Instrument Pnl. w/o A.T.C.	70	—	—	—	—	—	—	1	—	—	—	—	2983 107
	Instrument Pnl. w/o A.T.C.	71	—	—	—	—	—	—	1	1	—	—	—	3513 441
	Engine Compt. w/A.T.C.	71	—	—	—	—	—	—	—	1	1	1	—	3513 201
	Inst. Pnl. w/o A.T.C.	70	—	—	—	—	—	—	1	—	—	—	—	2983 139
	Inst. Pnl. w/o A.T.C.	70	—	—	—	—	—	—	—	1	1	1	—	2926 415
	Inst. Pnl. w/o A.T.C.	71	—	—	—	—	—	—	—	1	1	1	1	3513 443
	Inst. Pnl. w/A.T.C.	70	—	—	—	—	—	—	1	1	1	1	1	2926 272
	Inst. Pnl. w/A.T.C.	71	—	—	—	—	—	—	—	1	1	1	1	3513 177
	Control Jumper w/A.T.C.		—	—	—	—	—	—	1	—	—	—	—	2983 101
	D		—	—	—	—	—	—	—	1	—	—	—	2983 138
	Control Jumper w/A.T.C.	70	—	—	—	—	—	—	—	1	1	1	—	2926 758
	w/A.T.C.	71	—	—	—	—	—	—	—	1	1	1	—	3513 454
24-24-140	BEZEL, Spot Cooler													
	P	70	—	—	—	—	—	—	1	—	—	—	—	2984 860
	P-E, P-L, D-E	71	—	—	—	—	—	—	1	1	—	—	—	2985 006
	P-M, P-H, P-P, D-L, D-M, D-H	71	—	—	—	—	—	—	1	1	—	—	—	2985 012
	Blue	70	—	—	—	—	—	—	—	2	2	2	2	4483 FB7
	Green	70	—	—	—	—	—	—	—	2	2	2	2	4483 EF8
	Teal	70	—	—	—	—	—	—	—	2	2	2	2	4483 FP6
	Light Tan	70	—	—	—	—	—	—	—	2	2	2	2	4483 FT4
	Dark Tan	70	—	—	—	—	—	—	—	2	2	2	2	4483 FT8
	Burgundy	70	—	—	—	—	—	—	—	2	2	2	2	4483 EM9
	Red	70	—	—	—	—	—	—	—	2	2	2	2	4483 FR9
	Black	70	—	—	—	—	—	—	—	2	2	2	2	4483 FX9
	Light Gold	70	—	—	—	—	—	—	—	2	2	2	2	4483 FY4
	Dark Gold	70	—	—	—	—	—	—	—	2	2	2	2	4483 EY8
	Gun Metal	71	—	—	—	—	—	—	—	2	2	2	2	4483 GA6
	Dark Blue	71	—	—	—	—	—	—	—	2	2	2	2	4483 GB7
	Russet	71	—	—	—	—	—	—	—	2	2	2	2	4483 GE9
CARLINES	J - Challenger B - Barracuda	V - Valiant L - Dart	R - Belvedere - Satellite W - Coronet - Charger	P - Plymouth D - Dodge	C - Chrysler Y - Imperial									

AR Indicates use as required.

# Indicates parts not listed in any previous parts book.

Numerals in parentheses ( ) refer to notes.

★ Indicates change or addition.

Printed in U.S.A.  
January 1972

CODE	PART NAME	ENG. TYPE OR CU.IN.	V	B	L	R	W	P	D	C	C	C	Y	PART NUMBER
			1-2	1-2	1-2	1-2	1-2	1-2	1-2	1	2	3	1	
<b>24-24-0 CONTROLS Cont'd.</b>														
24-24-140	BEZEL Cont'd.													
	Dark Green	71	—	—	—	—	—	—	—	2	2	2	2	4483 GF7
	Dark Saddle	71	—	—	—	—	—	—	—	2	2	2	2	4483 GT6
	Black	71												4483 EX9
	Gold	71	—	—	—	—	—	—	—	—	—	—	2	4483 GY6
	Dark Blue	71	—	—	—	—	—	—	—	—	—	—	2	4483 GB9
	Burgundy	71	—	—	—	—	—	—	—	—	—	—	2	4483 GM9
	71													
	Bezel, Control A/Cond.													
	Low Line	70	1	—	—	—	—	—	—	—	—	—	—	2864 538
	Except Low Line	70	1	—	—	—	—	—	—	—	—	—	—	2884 890
	V-L, All, L-L Fast Back	71	1	—	1	—	—	—	—	—	—	—	—	2884 890
	R, W	71	—	—	—	1	1	—	—	—	—	—	—	3431 127
	R, W	70	—	—	—	1	1	—	—	—	—	—	—	2884 576
	Y	70	—	—	—	—	—	—	—	—	—	—	1	3431 271
	Y	71	—	—	—	—	—	—	—	—	—	—	1	3431 290
	Auto. Temp. Control,	70	—	—	—	—	—	—	—	1	1	1	—	2884 232
	P	70	—	—	—	—	—	1	—	—	—	—	—	2884 118
	C	71	—	—	—	—	—	—	—	1	1	1	—	3431 201
	Y	70	—	—	—	—	—	—	—	—	—	—	1	2884 320
	Y	71	—	—	—	—	—	—	—	—	—	—	1	3431 203
	Rr. A/Cond Blwr. Sw. Mtg. Sta.													
	Wgn.	71	—	—	—	—	—	1	1	—	—	—	—	3488 005
	Rr. Switch Mtg. Sta. Wgn. Only	70	—	—	—	—	—	—	1	—	—	—	—	2947 182
	Lens and Seal w/A.T.C Only	70	—	—	—	—	—	—	1	—	—	—	—	2884 355
	Lens and Seal w/A.T.C	71	—	—	—	—	—	—	1	—	—	—	—	3431 190
	Rr. A/C Switch	70	—	—	—	—	—	1	—	—	—	—	—	2947 040
	Rr. Switch Mtg. Sta. Wgn. Only	70	—	—	—	—	—	1	—	—	—	—	—	2947 895
	NOTE: For Further Information See P.T.C. 1-48-70													
24-24-150	SWITCHES													
	Evap. Temp. Control		1	—	1	—	—	—	—	—	—	—	—	2837 223
	Push Button		1	1	1	1	1	1	1	1	1	1	1	3431 020
	Push Button Vacuum, w/Cable	70	—	—	—	1	1	—	—	—	—	—	—	3431 017
	A/C and Htr. Control, 6 Position	71	—	—	—	1	1	—	—	—	—	—	—	3431 116
	Vacuum Recirculating, A.T.C. Only		—	—	—	—	—	1	1	1	1	1	1	2936 754
	Master, A.T.C. Only	70	—	—	—	—	—	1	1	1	1	1	1	2837 382
	71		—	—	—	—	—	1	1	1	1	1	1	3441 538
	CLUTCH, A.T.C. Only		—	—	—	—	—	1	1	1	1	1	1	2837 386
	Master, Clutch, w/Brkt., A.T.C. Only	70	—	—	—	—	—	1	1	1	1	1	1	2936 363
	Push Button, w/A.T.C.	70	—	—	—	—	—	1	1	—	—	—	—	3431 019
	71		—	—	—	—	—	1	1	—	—	—	—	3431 181
	NOTE: For Further Information See P.T.C. 1-48-770													
24-24-151	COVER, Spotcooler Hole	70	—	—	—	—	—	1	—	—	—	—	—	2984 898
	Inst. Pnl. Spot Cooler Hole P-E, P-L, D-E71		—	—	—	—	—	1	1	—	—	—	—	2985 007
	P-M, P-H, P-P, D-L, D-M, D-H	71	—	—	—	—	—	1	1	—	—	—	—	2985 013
24-24-154	BRACKET, Master and Clutch Switch Mtg.	70	—	—	—	—	—	1	1	1	1	1	1	2936 364
24-24-155	PLATE, Mtg., w/A.T.C.	70	—	—	—	—	—	—	—	1	1	1	1	2884 231
24-24-156	KNOBS													
	Heater Temp. Control		—	—	—	—	—	—	—	1	1	1	1	2884 418
	A/C and Heater Control		—	AR	—	—	—	—	—	—	—	—	—	3431 330
	Heater Temp. Control	71	—	—	—	1	1	—	—	—	—	—	—	3431 158
	Heater and Defroster	71	—	—	—	1	1	—	—	—	—	—	—	3431 159
	Rr. A/C Switch	71	—	—	—	—	—	—	—	1	1	1	—	3488 199
	Thumbwheel, w/A.T.C.		—	—	—	—	—	1	—	—	—	—	—	2884 119
	70		—	—	—	—	—	—	—	1	—	—	—	2884 209
	70		—	—	—	—	—	—	—	1	1	1	1	2884 239
	70		—	—	—	—	—	—	—	—	—	—	1	2884 531
	NOTE: For Further Information See P.T.C. 1-48-942													

3595033

CARLINES J - Challenger B - Barracuda V - Valiant L - Dart R - Belvedere - Satellite W - Coronet - Charger P - Plymouth D - Dodge C - Chrysler Y - Imperial

AR Indicates use as required. # Indicates parts not listed in any previous parts book. Numerals in parentheses ( ) refer to notes. \* Indicates change or addition. Printed in U.S.A. January 1972

CODE	PART NAME	ENG. TYPE OR CU.IN.	V	B	L	R	W	P	D	C	C	C	Y	PART NUMBER
			1-2	1-2	1-2	1-2	1-2	1-2	1-2	1	2	3	1	
<b>24-24-0 CONTROLS Cont'd.</b>														
24-24-159	REGULATOR, Control Vacuum	70	—	—	—	—	—	—	1	—	—	—	—	2884 333
	(Also in 1-48-374)	70	—	—	—	—	—	—	—	1	—	—	—	2884 277
		70	—	—	—	—	—	—	—	1	1	1	—	2884 368
	A/C and Htr. Control Vacuum	71	—	—	—	—	—	—	1	1	—	—	—	3431 263
		71	—	—	—	—	—	—	—	1	1	1	1	3431 206
24-24-161	CONTROL													
	Auto Temp. Complete	70	—	—	—	—	—	—	1	—	—	—	—	2884 341
		70	—	—	—	—	—	—	—	1	—	—	—	2884 354
		70	—	—	—	—	—	—	—	1	1	1	—	2884 373
		71	—	—	—	—	—	—	—	1	1	1	—	3431 197
		71	—	—	—	—	—	—	—	—	—	—	1	3431 198
		70	—	—	—	—	—	—	—	—	—	—	1	2884 372
	Servo Unit A.T.C. Comp.	71	—	—	—	—	—	—	—	1	1	1	1	3441 530
	A/Cond. and Htr., w/A.T.C.	70	—	—	—	—	—	—	1	1	1	1	1	2936 042
	A/Cond. and Htr., w/Out A.T.C.	70	—	—	—	—	—	—	1	1	1	1	1	3431 270
		71	—	—	—	—	—	—	—	1	1	1	—	3431 196
		71	—	—	—	—	—	—	—	—	—	—	1	= 3431 289
	A/C and Htr., w/out A.T.C., Dual	70	—	—	—	—	—	—	—	1	1	1	—	2884 368
	w/Out A.T.C.	70	—	—	—	—	—	—	—	1	—	—	—	2884 349
	Vacuum Regulator	70	—	—	—	—	—	—	—	1	—	—	—	2884 277
	w/Out A.T.C.	70	—	—	—	—	—	—	—	1	—	—	—	2884 332
	A/C and Htr. Temp. Comp.	71	—	—	—	—	—	—	—	1	1	—	—	3431 262
	NOTE: For Further Information See P.T.C. 1-48-4													
24-24-164	EXTENSION and COVER													
	Off		1	—	1	—	—	—	—	—	—	—	—	2864 858
	Max. A/C		1	—	1	—	—	—	—	—	—	—	—	2864 859
	A/Cond.		1	—	1	—	—	—	—	—	—	—	—	2864 860
	Heat		1	—	1	—	—	—	—	—	—	—	—	2864 861
	Defrost		1	—	1	—	—	—	—	—	—	—	—	2864 862
	Off		—	1	—	—	—	—	—	—	—	—	—	2884 711
	Max. A/C		—	1	—	—	—	—	—	—	—	—	—	2884 712
	A/Cond.		—	1	—	—	—	—	—	—	—	—	—	2884 713
	Heat		—	1	—	—	—	—	—	—	—	—	—	2884 714
	Defrost		—	1	—	—	—	—	—	—	—	—	—	2884 715
	EXTENSION, Push Button													
	Off 70		—	—	—	1	1	—	—	—	—	—	—	2884 741
	Max. A/C 70		—	—	—	1	1	—	—	—	—	—	—	2884 740
	A/Cond. 70		—	—	—	1	1	—	—	—	—	—	—	2884 739
	Heat 70		—	—	—	1	1	—	—	—	—	—	—	2884 738
	Defrost 70		—	—	—	1	1	—	—	—	—	—	—	2884 737
	Temp 70		—	—	—	1	1	—	—	—	—	—	—	2884 735
	Fan 70		—	—	—	1	1	—	—	—	—	—	—	2884 734
	w/out A.T.C.													
	Off		—	—	—	—	—	—	1	1	—	—	—	2884 251
	Max. A/C		—	—	—	—	—	—	1	1	—	—	—	2884 252
	A/Cond.		—	—	—	—	—	—	1	1	—	—	—	2884 253
	Heat		—	—	—	—	—	—	1	1	—	—	—	2884 254
	Defrost		—	—	—	—	—	—	1	1	—	—	—	2884 255
	w/A.T.C.													
	Off		—	—	—	—	—	—	1	—	—	—	—	2884 121
	Auto.		—	—	—	—	—	—	1	—	—	—	—	2884 122
	Hi Auto		—	—	—	—	—	—	1	—	—	—	—	2884 123
	Defrost		—	—	—	—	—	—	1	—	—	—	—	2884 124
	Hi Defrost		—	—	—	—	—	—	1	—	—	—	—	2884 125
	w/out A.T.C.													
	Off		—	—	—	—	—	—	—	1	—	—	—	2884 260
	Max. A/C		—	—	—	—	—	—	—	1	—	—	—	2884 261
	A/Cond.		—	—	—	—	—	—	—	1	—	—	—	2884 468
	Defrost		—	—	—	—	—	—	—	1	—	—	—	2884 263
	w/A.T.C.													
	Off		—	—	—	—	—	—	—	1	—	—	—	2884 215
	Auto		—	—	—	—	—	—	—	1	—	—	—	2884 216
	Hi Auto 70		—	—	—	—	—	—	—	1	—	—	—	2884 217
	Defrost 70		—	—	—	—	—	—	—	1	—	—	—	2884 218
CARLINES	J - Challenger B - Barracuda	V - Valiant L - Dart	R - Belvedere - Satellite W - Coronet - Charger	P - Plymouth D - Dodge	C - Chrysler Y - Imperial									

AR Indicates use as required.

# Indicates parts not listed in any previous parts book.

Numerals in parentheses ( ) refer to notes.

★ Indicates change or addition.

Printed in U.S.A.  
January 1972

CODE	PART NAME	ENG. TYPE OR CU.IN.	V	B	L	R	W	P	D	C	C	C	Y	PART NUMBER
			1-2	1-2	1-2	1-2	1-2	1-2	1-2	1	2	3	1	
<b>24-24-0 CONTROLS Cont'd.</b>														
24-24-164	EXTENSION and COVER Cont'd.													
	Hi Defrost 70		—	—	—	—	—	—	1	—	—	—	—	2884 219
	w/out A.T.C. Off		—	—	—	—	—	—	—	1	1	1	1	2884 383
	Max. A/C		—	—	—	—	—	—	—	1	1	1	1	2884 384
	A/Cond.		—	—	—	—	—	—	—	1	1	1	1	2884 385
	Heat		—	—	—	—	—	—	—	1	1	1	1	2884 386
	Defrost		—	—	—	—	—	—	—	1	1	1	1	2884 387
	w/A.T.C. Off		—	—	—	—	—	—	—	1	1	1	1	2884 390
	Auto		—	—	—	—	—	—	—	1	1	1	1	2884 391
	Hi Auto		—	—	—	—	—	—	—	1	1	1	1	2884 392
	Defrost		—	—	—	—	—	—	—	1	1	1	1	2884 393
	Hi Defrost		—	—	—	—	—	—	—	1	1	1	1	2884 394
	Off 70		—	—	—	—	—	—	—	—	—	—	1	2884 457
	Auto 70		—	—	—	—	—	—	—	—	—	—	1	2884 458
	Hi Auto 70		—	—	—	—	—	—	—	—	—	—	1	2884 459
	Defrost 70		—	—	—	—	—	—	—	—	—	—	1	2884 460
	Hi Defrost 70		—	—	—	—	—	—	—	—	—	—	1	2884 461
	NOTE: For Further Information See P.T.C. 1-48-12													
24-24-167	LAMP, A/Cond. and Heater Control		1	—	1	—	—	—	—	—	—	—	—	2864 842
	Temp Control, w/Socket	70	—	—	—	1	1	—	—	—	—	—	—	2884 575
		70	—	—	—	—	—	—	1	—	—	—	—	2884 265
	Auto. Temp. Control Mtg.	70	—	—	—	—	—	—	1	—	—	—	—	2884 214
	Auto. Temp. Control Thumbwheel, w/Bracket	70	—	—	—	—	—	—	—	1	—	—	—	2884 449
	Contact A/C and Htr. Control Lamp Socket		—	—	—	1	1	—	—	—	—	—	—	2256 966
	NOTE: For Further Information See P.T.C. 1-48-10													
24-24-169	LIGHTSHIELD, A/Cond. and Heater Control		1	—	1	—	—	—	—	—	—	—	—	2864 867
24-24-170	PAD, Push Button		1	—	1	—	—	—	—	—	—	—	—	2864 600
	V-S, L-M,		1	—	1	—	—	—	—	—	—	—	—	2884 489
			—	—	—	—	—	—	—	1	1	1	1	2884 240
24-24-177	SLIDER, A/Cond. and Heater Control		—	—	—	—	—	—	1	—	—	—	—	2884 259
	Temp. Fan 70		—	—	—	—	—	—	—	1	—	—	—	2884 205
24-24-183	NUT, Push Auto. Temp. Control Gear Retainer		—	—	—	—	—	—	—	2	2	2	2	2197 678
24-24-184	COVER, A/Cond. and Heater Vent	Rt.	—	—	—	—	—	—	1	1	—	—	—	3441 188
	Lt. 71		—	—	—	—	—	—	—	1	—	—	—	3441 765

**24-25-0 COMPRESSOR**

NOTE: The part number stamped on Compressor Identification Plate is a production number and may be used to identify component parts requirement for that compressor (Example: Code 24-25-5)

24-25-2	PISTON RING PACKAGE		AR	AR	AR	AR	AR	AR	AR	AR	AR	AR	AR	2275 207
24-25-3	PISTON and CONNECTING ROD PACKAGE													
	V2 Compressor		AR	AR	AR	AR	AR	AR	AR	AR	AR	AR	AR	2932 972
	RV2 Compressor		AR	AR	AR	AR	AR	AR	AR	AR	AR	AR	AR	2541 330
24-25-5	COMPRESSOR'S													
	V2, Replaces Production Part No's.													
	2951 193, 2951 194, 2951 195,													
	2951 220,													
	2951 268, 2951 271, 2953 349,													
	2953 568, 2961 947,													
	2953 588, 3462 019, 2960 782,													
	2941 998,													
	3462 350, 3462 419, 3462 420,													
	2961 920, 3512 708													
	3462 919, 3462 920, 3462 998,													
	3512 062, 3512 706, 3512 707													
	3491 270, 3491 271, 3484 252, PER													
	NOTE		1	1	1	1	1	1	1	—	—	—	—	3484 253
CARLINES	J - Challenger B - Barracuda	V - Valiant L - Dart	R - Belvedere - Satellite W - Coronet - Charger				P - Plymouth D - Dodge				C - Chrysler Y - Imperial			

AR Indicates use as required.

# Indicates parts not listed in any previous parts book.

Numerals in parentheses ( ) refer to notes.

★ Indicates change or addition.

Printed in U.S.A.  
January 1972

CODE	PART NAME	ENG. TYPE OR CU.IN.	V	B	L	R	W	P	D	C	C	C	Y	PART NUMBER
<b>24-25-0 COMPRESSOR Cont'd.</b>														
24-25-5	COMPRESSORS Cont'd.													
	RV2, Replaces Production Part No's.													
	2951 269, 2951 270, 3462 005,													
	3462 020, 3512 710, 3512 711,													
	3462 021, 3462 351, 3462 352, PER													
	NOTE		—	—	—	1	1	1	1	1	1	1	1	2941 875
24-25-8	LUBRICANT, Compressor, 1 Quart		AR	AR	AR	AR	AR	AR	AR	AR	AR	AR	AR	1450 769
24-25-10	SUPPORTS, Compressor													
	Rt. 225		1	1	1	1	1	1	1	—	—	—	—	2806 152
	Rt. 318		1	1	1	1	1	1	1	—	—	—	—	3462 949
	Rt. 71 318		1	1	1	1	1	1	1	—	—	—	—	3577 173
	Rt. 71 340		1	1	1	1	1	—	—	—	—	—	—	3577 173
	Rt. 71 360		—	—	—	—	—	1	1	1	1	1	—	3577 173
	Rr. 225		1	—	1	—	—	—	—	—	—	—	—	2806 812
	Rr. 225		—	1	—	1	1	1	1	—	—	—	—	2946 134
	Rr. Rt. 383		—	1	—	1	1	1	1	1	1	1	—	3462 354
	Rr. Lt. 383		—	1	—	1	1	1	1	1	1	1	—	3462 022
	Rr. Rt. 440		—	1	—	1	1	1	1	1	1	1	1	3462 353
	Rr. Lt. 440		—	1	—	1	1	1	1	1	1	1	1	3462 023
24-25-15	BRACKET'S													
	Compressor Mtg.	Frnt.	225	1	1	1	1	1	1	—	—	—	—	2468 809
	W/318, 340, 360 Eng.			1	1	1	1	1	1	1	1	1	—	2951 822
		Frnt.	383	—	1	—	1	1	1	1	1	1	1	2899 526
		Frnt.	440	—	1	—	1	1	1	1	1	1	1	2899 526
	w/318, 340 Eng.			1	1	1	1	1	1	—	—	—	—	2951 866
		Rr.	360	—	—	—	—	1	1	1	1	1	—	2951 866
		Rr.	383	—	1	—	1	1	1	1	1	1	—	2951 809
		Rr.	440	—	1	—	1	1	1	1	1	1	1	2899 961
	Compressor Support Side			1	1	1	1	1	1	—	—	—	—	3418 261
		Lt.	340	1	1	1	—	—	—	—	—	—	—	3418 261
		Lt.	360	—	—	—	—	1	1	1	1	1	—	3418 261
	STRAP, Alternator Adj.		70	—	1	—	1	1	1	1	1	1	1	1999 184
24-25-20	PULLEY and HUBS													
	Single Groove, Warner 6 5/8" O.D.			1	1	1	1	1	1	1	—	—	—	2521 824
	Double Groove 5 3/8" O.D. Type Warner			1	1	1	1	1	1	1	1	1	1	2837 163
24-25-25	PULLEY, Compressor Drive		225	1	1	1	1	1	1	—	—	—	—	2202 794
24-25-31	SHIELD, Idler Pulley Bearing		225	1	1	1	1	1	1	—	—	—	—	2658 758
24-25-35	PULLEY, Compressor Idler		225	1	1	1	1	1	1	1	—	—	—	2203 031
24-25-38	PLATE, Compressor Specification			—	—	—	—	1	1	1	1	1	—	2837 128
24-25-45	BRACKETS, Idler Pulley and Idler Roller			1	1	1	1	1	1	—	—	—	—	2277 731
	Idler Pulley		225	1	1	1	1	1	1	—	—	—	—	2203 035
24-25-70	CRANKSHAFT GAS SEAL PACKAGE			AR	AR	AR	AR	AR	AR	AR	AR	AR	AR	1426 501
24-25-78	NUT A/C, Htr. or A.T.C. Liq. Line Male													
	Mtg.		71	1	1	1	1	1	1	1	1	1	1	3441 740
24-25-84	HEAD, Compressor Cylinder			1	1	1	1	1	1	1	1	1	1	2000 083
	Up to April, 1971	Lt.		1	1	1	1	1	1	1	1	1	1	1999 502
	After April 1971	Lt.		1	1	1	1	1	1	1	1	1	1	= 3604 299
24-25-93	VALVE PLATE PACKAGE			1	1	1	1	1	1	1	1	1	1	2275 204
		Lt.		1	1	1	1	1	1	1	1	1	1	2275 205
24-25-94	GASKET, Cylinder Head			2	2	2	2	2	2	2	2	2	2	1990 584
	Valve Plate			2	2	2	2	2	2	2	2	2	2	1990 598
24-25-107	FITTING'S													
	Suction, For Compressor Part No's.													
	2951 194,													
	2953 568, 3462 350, 3462 351,													
	3462 352, 3462 920		70	1	1	1	1	1	1	1	1	1	1	2938 228
	2951 193, 3512 062		70	1	1	1	1	1	1	1	1	1	1	2938 229
	2951 195, 3462 998		70	1	1	1	1	1	1	1	1	1	1	2938 227

CARLINES J - Challenger V - Valiant R - Belvedere - Satellite P - Plymouth C - Chrysler  
 B - Barracuda L - Dart W - Coronet - Charger D - Dodge Y - Imperial

AR Indicates use as required.

Numerals in parentheses ( ) refer to notes.

Printed in U.S.A.

# Indicates parts not listed in any previous parts book.

★ Indicates change or addition.

January 1972



CODE	PART NAME	ENG. TYPE OR CU.IN.	V	B	L	R	W	P	D	C	C	C	Y	PART NUMBER
			1-2	1-2	1-2	1-2	1-2	1-2	1-2	1	2	3	1	
<b>24-25-0 COMPRESSOR Cont'd.</b>														
24-25-107	FITTINGS Cont'd.													
	2951 220, 2951 271, 3462 419,	70												2938 230
	2960 782	70	1	1	1	1	1	1	1	1	1	1	1	
	2951 268, 2951 269, 2951 270,	70												
	3462 005	70	1	1	1	1	1	1	1	1	1	1	1	2938 176
	2953 349, 3491 270	70	1	1	1	1	1	1	1	1	1	1	1	2941 891
	2953 588, 3491 271	70	1	1	1	1	1	1	1	1	1	1	1	2941 846
	2941 998, 3484 252	70	1	1	1	1	1	1	1	1	1	1	1	2010 872
	3462 019, 3462 020, 3462 021	70	1	1	1	1	1	1	1	1	1	1	1	3406 191
	3462 420, 3462 919	70	1	1	1	1	1	1	1	1	1	1	1	3408 425
	2951 195, 3462 998	71	1	1	1	1	1	1	1	1	1	1	1	3555 190
	2941 998, 3484 252	71	1	1	1	1	1	1	1	1	1	1	1	3555 191
	2953 349, 3491 270	71	1	1	1	1	1	1	1	1	1	1	1	3555 192
	2953 588, 3491 271	71	1	1	1	1	1	1	1	1	1	1	1	3555 193
	2951 193, 3512 062	71	1	1	1	1	1	1	1	1	1	1	1	3555 194
	2951 194, 2953 568, 3462 350, 3462 920	70	1	1	1	1	1	1	1	1	1	1	1	3514 387
	2951 220, 2951 271, 2960 782, 3462 419	70	1	1	1	1	1	1	1	1	1	1	1	3514 388
	3462 019, 2961 947	70	1	1	1	1	1	1	1	1	1	1	1	3514 389
	Discharge, For Compressor No's.													
	2951 193, 2951 194, 2951 195,													
	3462 420,													
	3462 920, 3462 998, 3512 062	70	1	1	1	1	1	1	1	1	1	1	1	2938 219
	2941 998, 3484 252	70	1	1	1	1	1	1	1	1	1	1	1	2814 688
24-25-110	GASKET, Suction Fitting		1	1	1	1	1	1	1	1	1	1	1	1997 446
	GASKET, w/Terminal, E.T.R. Valve		—	—	—	—	—	—	—	—	—	—	—	2837 403
24-25-114	SCREEN, Compressor Suction		1	1	1	1	1	1	1	1	1	1	1	1996 845
	FILTER, Comp. Suction		—	—	—	—	—	—	—	—	—	—	—	3484 412
24-25-127	CAP, 1/4", Flare Fitting Seal		AR	AR	AR	AR	AR	AR	AR	AR	AR	AR	AR	1989 202
	Cap A/C and Htr. Mtg. Screw		—	1	—	1	1	—	—	—	—	—	—	2423 737
24-25-132	VALVES													
	Pressure Regulator For Compressor's													
	2951 194, 2951 220, 2951 268,													
	2951 269,													
	3462 005		1	1	1	1	1	1	1	1	1	1	1	2776 146
	Temp. Regulator		1	1	1	1	1	1	1	1	1	1	1	2837 402
24-25-133	CORE, Gage Fitting Valve		AR	AR	AR	AR	AR	AR	AR	AR	AR	AR	AR	1992 947
	Discharge Line Check		1	1	1	1	1	1	1	1	1	1	1	1992 947
24-25-135	SEALS													
	Pressure Regulator Valve		1	1	1	1	1	1	1	1	1	1	1	1994 410
	Discharge Fitting		1	1	1	1	1	1	1	1	1	1	1	2008 388
24-25-137	SPRING, Pressure Regulator Valve Spacer		1	1	1	1	1	1	1	1	1	1	1	1994 408
24-25-154	CRANKSHAFT PACKAGE													
	V2 Compressor		AR	AR	AR	AR	AR	AR	AR	AR	AR	AR	AR	2815 762
	RV2 Compressor		AR	AR	AR	AR	AR	AR	AR	AR	AR	AR	AR	2815 755
24-25-156	SCREW'S, Compressor Drive Clutch Pulley													
	Mtg.													
	(Pitts Type)		1	1	1	1	1	1	1	1	1	1	1	1819 843
	(Warner Type)		1	1	1	1	1	1	1	—	—	—	—	1658 638
24-25-157	WASHER, Compressor Clutch Pulley Mtg.		1	1	1	1	1	1	1	1	1	1	1	2097 102
24-25-160	BEARING, Crankshaft Ball													
	V2 Compressor		1	1	1	1	1	1	1	—	—	—	—	1854 829
	RV2 Compressor		1	1	1	1	1	1	1	1	1	1	1	2019 681
	Bearing Rear Main Sleeve V2, RV2		1	1	1	1	1	1	1	1	1	1	1	1984 152
24-25-162	CRANKSHAFT BEARING HOUSING													
	PACKAGE													
	V2 Compressor, w/out Bearing		AR	AR	AR	AR	AR	AR	AR	AR	AR	AR	AR	2196 315
	RV2 Compressor		AR	AR	AR	AR	AR	AR	AR	AR	AR	AR	AR	2541 332
	V2 Compressor, w/Bearing		AR	AR	AR	AR	AR	AR	AR	AR	AR	AR	AR	3420 916
CARLINES	J - Challenger B - Barracuda	V - Valiant L - Dart	R - Belvedere - Satellite W - Coronet - Charger	P - Plymouth D - Dodge	C - Chrysler Y - Imperial									

AR Indicates use as required.

# Indicates parts not listed in any previous parts book.

Numerals in parentheses ( ) refer to notes.

★ Indicates change or addition.

Printed in U.S.A.  
January 1972

CODE	PART NAME	ENG. TYPE OR CU.IN.	V	B	L	R	W	P	D	C	C	C	Y	PART NUMBER
			1-2	1-2	1-2	1-2	1-2	1-2	1-2	1	2	3	1	
<b>24-25-0 COMPRESSOR Cont'd.</b>														
24-25-168	WASHER, Crankshaft Thrust		1	1	1	1	1	1	1	1	1	1	1	1747 982
24-25-189	SEAL, Bearing Housing		1	1	1	1	1	1	1	1	1	1	1	1982 542
24-25-219	BEARING, Compressor Clutch		1	1	1	1	1	1	1	1	1	1	1	1769 318
24-25-232	COIL, Compressor Clutch Field		1	1	1	1	1	1	1	1	1	1	1	2097 105
	1 3/8" Thick x 4 13/16" O.D.		1	1	1	1	1	1	1	1	1	1	1	2837 162
	1 7/8" Thick x 4 3/16" O.D.		1	1	1	1	1	1	1	1	1	1	1	
24-25-234	RINGS, Compressor Clutch		1	1	1	1	1	1	1	1	1	1	1	2097 101
	External	3/4" I.D.	1	1	1	1	1	1	1	1	1	1	1	3441 055
		1 3/32" I.D.	1	1	1	1	1	1	1	1	1	1	1	2485 587
		1 1/8" I.D.	1	1	1	1	1	1	1	1	1	1	1	3441 054
	Internal	2 1/16" I.D.	1	1	1	1	1	1	1	1	1	1	1	2097 103
		2 1/2" I.D.	1	1	1	1	1	1	1	1	1	1	1	2021 191
24-25-246	OIL PUMP PACKAGE		1	1	1	1	1	1	1	1	1	1	1	1747 988
24-25-252	SEAL, Oil Pump Cover Oil		1	1	1	1	1	1	1	1	1	1	1	2869 545
24-25-258	SUMP, Compressor Oil		1	1	1	1	1	1	1	1	1	1	1	1982 545
24-25-260	GASKET, Oil Sump		1	1	1	1	1	1	1	1	1	1	1	
<b>24-26-0 RECEIVER DRIER</b>														
24-26-20	DRIER, Receiver, Less Switch		1	1	1	1	1	1	1	1	1	1	1	3441 244
	w/Tapped Holes and Plugs	70												
	Rec. Drier A/C., Htr. or A.T.C. w/Pipe		1	1	1	1	1	1	1	1	1	1	1	3441 738
	Plug Less Switch, up to Nov. 1, 1970													
	Rec. Drier A/C and Htr. or A.T.C. w/Pipe		1	1	1	1	1	1	1	1	1	1	1	= 3502 015
	Plug													
	Less Switch After Nov. 1, 1970	71	1	1	1	1	1	1	1	1	1	1	1	2219 155
24-26-35	BRACKET, Receiver Drier Mtg.		1	1	1									2219 155
		71				1	1							3441 844
	w/Leece-Neville Alt., 383, 440 Eng.	71				1	1							2607 440
		70				1	1							2936 474
		70						1	1	1	1	1	1	2607 526
		71											1	3441 890
24-26-100	MUFFLER and TUBE, Compressor		1		1									3441 279
	Suction, V-1, L-1	70	1		1									3441 824
	Suction V, L,	71	225	1		1								3441 278
	Discharge, V-1, L-1	70	1		1									3441 343
	Suction, V-2, L-2		1		1									
	Discharge, V-2, L-2 Up to Jan. 1, 1970	70	1		1									3441 411
	After Jan. 1, 1970	70	1		1									3441 517
	Discharge, V, L,	71	225	1		1								3441 825
	V, L, 318, 340 Eng.,	71	1		1									3441 517
	Suction, B, J, w/RG. Eng.	70	225		1									3441 242
	Suction B.J.,	71	225		1									3441 818
	Discharge, B, J, w/RG. Eng.	70	225		1									3441 243
	Discharge, B, J,	71	225		1									3441 817
	R, W,	71	225				1	1						3441 817
	Suction, B,J, w/LA. Eng. (318 or 340 Cu. In.)	70		1										3441 192
	Suction, B, J, 318, 340 Eng.	71		1										3441 834
	Discharge, B, J, w/LA Eng.													
	Up to Jan. 1, 1970	70		1										3441 193
	After Jan. 1, 1970	70		1										3441 523
	Discharge, B, J, 318 Eng., All	71		1										3441 523
	B-S, J-H, 340 Eng.,	71		1										3441 523
	R, W, 318, 340 Eng.,	71				1	1							
	Suction, B, J, w/B and RB Eng. (383, 426 or 440 Cu. In.)	70		1										3441 085
	Suction, B, J, 383, 440 Eng.,	71		1										3441 831

CARLINES J - Challenger V - Valiant  
B - Barracuda L - Dart

R - Belvedere - Satellite  
W - Coronet - Charger

P - Plymouth  
D - Dodge

C - Chrysler  
Y - Imperial

AR Indicates use as required.

Numerals in parentheses ( ) refer to notes.

Printed in U.S.A.  
January 1972

# Indicates parts not listed in any previous parts book.

★ Indicates change or addition.

CODE	PART NAME	ENG. TYPE OR CU. IN.	V	B	L	R	W	P	D	C	C	C	Y	PART NUMBER
			1-2	1-2	1-2	1-2	1-2	1-2	1-2	1	2	3	1	
<b>24-26-0 RECEIVER DRIER Cont'd.</b>														
24-26-100	MUFFLER AND TUBE Cont'd.													
	Discharge, B, J, w/B and RB Eng.			1										3441 088
	Up to Jan. 1, 1970	70		1										3441 524
	After Jan. 1, 1970	70		1										3441 524
	Discharge, B, J, 383, 440 Eng.,	71		1										3441 524
	R, W, 383, 440 Eng.,	71				1	1							3441 271
	Suction, R, W, w/RG. Eng.	70	225			1	1							3441 818
	Suction, R, W,	71	225			1	1							
	Suction, R, W, w/LA Eng. (318 or 340					1	1							3441 344
	Cu. In.)	70				1	1							3441 834
	Suction, R, W, 318, 340 Eng.,	71				1	1							3441 845
	R, W, 383, 440 Eng., Leece-Neville Alt.	71				1	1							
	Discharge, R, W, w/LA Eng. Up to					1	1							2936 794
	Jan. 1, 1970	70				1	1							3441 518
	After Jan. 1, 1970 w/225 Eng.	70				1	1							3441 519
	After Jan. 1, 1970 w/318 Eng.	70				1	1							
	Suction, R, W, w/B and RB Eng. (383,					1	1							3441 280
	426 or 440 Cu. In.)	70				1	1							3441 831
	Suction, R, W, 383, 440 Eng.,	71				1	1							
	Discharge, R, W, w/B and RB Eng. Up					1	1							3441 283
	to Jan. 1, 1970	70				1	1							3441 520
	After Jan. 1, 1970	70				1	1							
	Suction, P, D, w/RG Eng. (198 or 225							1	1					2936 574
	Cu. In.)	70						1	1					2936 498
	Discharge, P,D, w/RG. Eng.	70						1	1					
	Suction, P, D, w/LA Eng. (318 or 340							1	1					2936 724
	Cu. In.)	70						1	1					3441 832
	Suction, P, D, 318, 360 Eng.,	71						1	1					3441 199
	Discharge P, D, 318, 340, 360	70						1	1					3441 522
	P, D, 318, 360 Up to Feb. 1971							1	1					= 3441 992
	P, D, 318, 360 After Feb. 1971							1	1					= 3441 992
	C, 360	71								1				
	Suction, P, D, 383, 440 Eng.							1	1					3441 018
	W/Leece Neville Alternator									1	1	1		3441 018
	Suction, W/Leece Neville Alternator		All							1	1	1	1	3441 232
	w/EED Alternator							1	1	1	1	1	1	
	Discharge, P, D, C, w/B or RB Eng.							1	1	1	1	1		2936 498
	(383, 426 or 440 Cu. In.)	70						1	1	1	1	1		
	Suction, P, D, C, Sta. Wgn. Only,							1	1	1	1	1		2936 721
	w/RG. Eng. (198 or 225 Cu. In.)	70						1	1	1	1	1		
	Suction, P, D, C, Sta. Wgn. Only,							1	1	1	1	1		2936 723
	w/LA Eng. (318 or 340 Cu. In.)	70						1	1	1	1	1		
	Suction P, D, Sta. Wgn. Only Dual Unit							1	1					3441 833
	318, 360 Eng.	71						1	1					
	Suction, P, D, Sta. Wgn. Only, w/B													
	and RB Eng.													
	(383, 426 or 440) and w/Leece Neville							1	1					3441 019
	Alternator	70						1	1					
	Suction, Htr. or A.T.C. Dual Unit							1	1	1	1	1		3441 019
	w/Leece Neville Alt. w/383, 440 Eng.							1	1	1	1	1		
	Suction, P, D, C, Sta. Wgn. Only, w/B													
	and RB Eng.													
	(383, 426 or 440 Cu. In.) and							1	1	1	1	1		3441 233
	w/EED Alternator							1	1	1	1	1		3441 232
	Suction, Y, Except Dual Unit												1	3441 233
	Suction, Y, w/Dual Unit												1	2936 742
	Discharge, Y	70											1	

CARLINES

J - Challenger  
B - Barracuda

V - Valiant  
L - Dart

R - Belvedere - Satellite  
W - Coronet - Charger

P - Plymouth  
D - Dodge

C - Chrysler  
Y - Imperial

AR Indicates use as required.

# Indicates parts not listed in any previous parts book.

Numerals in parentheses ( ) refer to notes.

★ Indicates change or addition.

Printed in U.S.A.  
January 1972

CODE	PART NAME	ENG. TYPE OR CU.IN.	V	B	L	R	W	P	D	C	C	C	Y	PART NUMBER
			1-2	1-2	1-2	1-2	1-2	1-2	1-2	1	2	3	1	
<b>24-27-0 CONDENSER</b>														
24-27-5	CONDENSER		1	—	1	—	—	—	—	—	—	—	—	2936 778
	22", 32 Holes End Plates		—	1	—	1	1	—	—	—	—	—	—	3441 064
	24 1/4", 32 Holes End Plates		—	1	—	1	1	—	—	—	—	—	—	3441 065
	24 1/4", 16 Holes End Plates		—	1	—	1	1	—	—	—	—	—	—	3441 934
	w/318, 383, 440 Eng.	70	—	—	—	1	1	—	—	—	—	—	—	3441 422
		70	—	—	—	1	1	—	—	—	—	—	—	3441 423
		70	—	—	—	1	1	—	—	—	—	—	—	2936 297
	w/318, 383, 440 Eng.		—	—	—	—	—	1	1	—	—	—	—	2936 296
			—	—	—	—	—	—	—	1	1	1	—	2936 296
		26" 71	—	—	—	—	—	1	1	1	1	1	—	3441 614
	w/A.T.C. 70		—	—	—	—	—	—	—	—	—	—	1	2936 485
	w/A.T.C. 71		—	—	—	—	—	—	—	—	—	—	1	3441 535
<b>24-28-0 EVAPORATOR</b>														
24-28-3	COVERS, Roof Unit Tubes (Paint as Req'd.)													
	Tube At Roof Rail, 2 and 3 Seat Sta.													
	Wgn.		—	—	—	—	—	1	1	1	—	—	—	4106 EW2
	Tube Lower Rt., 2 and 3 Seat Sta.													
	Wgn.		—	—	—	—	—	1	1	1	—	—	—	4102 EW2
		Black 71	—	—	—	—	—	1	1	—	—	—	—	4102 FX9
		Black 71	—	—	—	—	—	—	—	1	—	—	—	4102 FX9
		White 71	—	—	—	—	—	—	—	1	—	—	—	4102 FW2
	Tube Upper Rt., 2 and 3 Seat Sta.													
	Wgn.		—	—	—	—	—	1	1	1	—	—	—	4104 EW2
	Dual Unit Hinge Lt. (Paint as Req.)		—	—	—	—	—	1	1	1	1	1	—	2025 EW2
24-28-6	SUB COOLER, Dual Unit w/A.T.C.	70	—	—	—	—	—	—	—	—	—	—	1	2936 486
24-28-7	TURNBUCKLE, Shut Off Door Lever Shaft													
	Adj.		1	—	1	—	—	—	—	—	—	—	—	2521 621
24-28-8	BRACKETS, Mounting													
	Roof Unit	Rt.	—	—	—	—	—	1	1	1	1	1	—	2936 410
		Lt.	—	—	—	—	—	1	1	1	1	1	—	2936 411
	Plenum		—	—	—	—	—	1	1	1	1	1	1	2936 228
	Rear Evap. Rear		—	—	—	—	—	—	—	—	—	—	1	2936 141
	Rear Evap. Side	Rt.	—	—	—	—	—	—	—	—	—	—	2	2936 142
		Lt.	—	—	—	—	—	—	—	—	—	—	2	2936 143
24-28-10	SCREENS													
	Evap. Coil Condensate		1	—	1	—	—	—	—	—	—	—	—	2521 953
		Lower	1	—	1	—	—	—	—	—	—	—	—	2837 243
24-28-13	REGULATOR, Evap. Coil Sensing													
	Up to Jan. 1, 1970	70	—	—	—	—	—	1	1	1	1	1	1	2936 358
	After Jan. 1, 1970		—	—	—	—	—	1	1	1	1	1	1	3441 450
24-28-16	STRAP, Defroster Tube Retention		1	—	1	—	—	—	—	—	—	—	—	3441 318
	A/C and Htr. Rear U/Body Hose		—	—	—	—	—	1	1	1	1	1	—	2945 704
	Rear U/Body Hose Sta. Wgn.		—	—	—	—	—	1	1	1	1	1	—	2945 704
24-28-17	CLAMPS													
	Water Valve Inlet and Outlet Hose		—	—	—	4	4	—	—	—	—	—	—	2521 726
	Roof Unit Liq. and Suction Frt. Hose													
	Mtg.		—	—	—	—	—	1	1	1	1	1	—	2936 886
	U/Body Tubes Mtg. Frt., w/A.T.C.		—	—	—	—	—	—	—	—	—	—	1	2936 886
	Roof Unit Liq. and Suction Frt. Hose													
	Mtg. Rr.		—	—	—	—	—	1	1	1	1	1	—	2936 887
	Rr. U/Body Tubes Mtg. Frt.		—	—	—	—	—	—	—	—	—	—	1	2936 887
24-28-18	ADAPTER, Tube w/Nut Kit													
	3/8" Dia. Tube		1	1	1	1	1	1	1	1	1	1	1	2485 914
	1/2		1	1	1	1	1	1	1	1	1	1	1	2485 915
	5/8		1	1	1	1	1	1	1	1	1	1	1	2485 916
	3/4		1	1	1	1	1	1	1	1	1	1	1	2485 920
24-28-19	GROMMETS													
	Liq. Tube	70	1	—	1	—	—	—	—	—	—	—	—	2837 109

CARLINES

J - Challenger  
B - BarracudaV - Valiant  
L - DartR - Belvedere - Satellite  
W - Coronet - ChargerP - Plymouth  
D - DodgeC - Chrysler  
Y - Imperial

AR Indicates use as required.

# Indicates parts not listed in any previous parts book.

Numerals in parentheses ( ) refer to notes.

★ Indicates change or addition.

Printed in U.S.A.  
January 1972

CODE	PART NAME	ENG. TYPE OR CU.IN.	V	B	L	R	W	P	D	C	C	C	Y	PART NUMBER
			1-2	1-2	1-2	1-2	1-2	1-2	1-2	1	2	3	1	
<b>24-28-0 EVAPORATOR Cont'd.</b>														
24-28-19	GROMMETS Cont'd.													
	w/Hose, Up to Feb. 1, 1970	70	—	1	—	—	—	—	—	—	—	—	—	3431 081
	w/Hose, After Feb. 1, 1970	70	—	1	—	—	—	—	—	—	—	—	—	3431 380
	W/Hose	71	—	1	—	—	—	—	—	—	—	—	—	3431 470
	Temp. Control Valve Mtg.	70	—	—	—	3	3	—	—	—	—	—	—	2521 676
	Htr. Core Tube Sealing, Dash	70	—	—	—	1	1	—	—	—	—	—	—	2607 182
	Control Vacuum Hose, Dash		1	—	1	1	1	—	—	—	—	—	—	3441 418
	Control Vac. Hose		1	—	1	—	—	—	—	—	—	—	—	3441 418
	Control Vac. Hose Dash	71	—	—	—	—	—	—	—	1	1	1	1	1886 101
	Hose Assy. A/C and Htr., Up to Dec. 1, 1970		—	—	—	1	1	—	—	—	—	—	—	3431 188
	Hose Assy. A/C and Htr. After Dec. 1, 1970		—	—	—	1	1	—	—	—	—	—	—	3431 472
	Roof Unit Rr. Liq. Hose	70	—	—	—	—	—	1	1	1	1	1	—	2277 767
24-28-22	SCREWS													
	Rr. Hsg. Mtg. to Frt. Hsg.		—	AR	—	AR	AR	—	—	—	—	—	—	3441 172
	Rr. Hsg. to Frt. Hsg.		—	—	—	AR	AR	—	—	—	—	—	—	3441 172
	Rr. Hsg. to Htr. Core Mtg.		—	—	—	—	—	2	2	2	2	2	2	3441 172
	Frt. Hsg. to Rr. Hsg. Mtg.		—	17	—	17	17	17	17	17	17	17	17	3441 172
	Frt. Hsg. to Rr. Hsg. Mtg.		—	—	—	—	—	2	2	2	2	2	2	3441 173
24-28-24	For HOSES Refer to Hose Chart Illustrated Section of Group 24.													
	Repair Kit, Htr. Control Vacuum Hose		—	—	—	—	—	AR	AR	AR	AR	AR	AR	2275 215
24-28-25	HOUSING and SCROLL													
	Scroll w/Air Inlet, Evap.		1	—	1	—	—	—	—	—	—	—	—	3441 033
24-28-29	BRACKETS													
	Suction Line Mtg.	70	225	—	—	—	—	1	1	—	—	—	—	3441 176
		70	318	—	—	—	—	1	1	—	—	—	—	3441 176
	Htr. Hose Support		225	—	1	—	—	1	1	—	—	—	—	3441 036
	Auto. Temp. Control Hose Support			—	—	—	—	—	—	—	—	—	1	2936 706
	NOTE: For Further Information See P.T.C. 1-48-559													
24-28-31	GASKET, Water Outlet and Inlet Tube Mtg.	70	—	—	—	1	1	—	—	—	—	—	—	2521 152
24-28-34	DOOR, w/Frame, Htr. Recirc.		1	—	1	—	—	—	—	—	—	—	—	2521 554
24-28-39	RESTRICTOR, Control Vacuum Hose		—	1	—	2	2	1	1	1	1	1	—	2884 074
24-28-40	COVER, w/Insulator, A/Cond and Htr. Top		1	—	1	—	—	—	—	—	—	—	—	2936 917
24-28-43	TRAY, DRAIN													
	Evap. Drain Pan		1	—	1	—	—	—	—	—	—	—	—	2936 894
	Evap. Coil and Drain	70	—	—	—	1	1	—	—	—	—	—	—	2923 907
	Rr. Evap. Unit Support Pan and Coil		—	—	—	—	—	—	—	—	—	—	1	2936 145
24-28-44	FERRULE, Condensate Drain Tube	70	—	—	—	2	2	—	—	—	—	—	—	2521 315
24-28-49	NUT, Rr. Blower Mtg.		—	—	—	—	—	1	1	—	—	—	—	2427 119
	Rr. Blower Switch Mtg.		—	—	—	—	—	1	—	—	—	—	—	2820 116
	Rr. Blower Switch and Bezel Mtg.		—	—	—	—	—	1	1	—	—	—	—	2427 119
24-28-64	KIT, Vacuum Tube Repair 1/4" I.D. 70 3/16 I.D.		—	AR	—	AR	AR	AR	AR	AR	AR	AR	AR	2448 620
	Vacuum Tube Repair 25 ft. long		—	—	—	—	—	AR	AR	AR	AR	AR	AR	2448 621
			—	1	—	—	—	—	—	—	—	—	—	2837 762
24-28-70	GRILLE, In Car Sensor		—	—	—	—	—	1	1	—	—	—	—	3441 013
24-28-72	CLIPS													
	Floor Air Hsg. Lt. Spotcooler Duct Retaining		—	1	—	—	—	—	—	—	—	—	—	2521 729
	Defroster Tube Retaining	70	—	—	—	2	2	—	—	—	—	—	—	2521 729
	Rt. Spotcooler Flex Tube Mtg.		—	—	—	—	—	2	2	—	—	—	—	2521 729
	Defroster Hose To Duct Mtg.	70	—	—	—	—	—	4	4	—	—	—	—	2521 729
	Tube to Spotcooler Duct Rt. and Lt.		—	—	—	—	—	—	—	1	1	1	1	2521 729
	Spotcooler Duct to Dist. Hsg.		—	—	—	—	—	—	—	1	1	1	1	2521 729
	Duct Mtg. to Spotcooler Lt.		—	—	—	—	—	—	—	3	3	3	3	2521 729
	Center Outlet and Rt. Spotcooler to Duct		—	2	—	—	—	—	—	—	—	—	—	2837 285
	Ctr. Rt., Outlet Duct to Outlet Mtg.	71	—	—	—	2	2	—	—	—	—	—	—	2837 285
CARLINES	J - Challenger B - Barracuda	V - Valiant L - Dart	R - Belvedere - Satellite W - Coronet - Charger	P - Plymouth D - Dodge	C - Chrysler Y - Imperial									

AR Indicates use as required.

# Indicates parts not listed in any previous parts book.

Numerals in parentheses ( ) refer to notes.

★ Indicates change or addition.

Printed in U.S.A.  
January 1972

CODE	PART NAME	ENG. TYPE OR CU.IN.	V	B	L	R	W	P	D	C	C	C	Y	PART NUMBER
			1-2	1-2	1-2	1-2	1-2	1-2	1-2	1	2	3	1	
<b>24-28-0 EVAPORATOR Cont'd.</b>														
24-28-72	CLIPS Cont'd.													
	Spotcooler Duct to Bezel Mtg. Lt.		—	1	—	—	—	—	—	—	—	—	—	2837 285
	Lower Lt. Spotcooler Duct		—	—	—	—	—	1	1	—	—	—	—	2837 285
	Spotcooler Duct Mtg.		—	—	—	—	—	2	4	—	—	—	—	2837 285
	Center Outlet Duct Mtg.		—	—	—	—	—	2	2	2	2	2	2	2837 285
	Ctr. Air Outlet Duct to Hsg. 71		—	—	—	—	—	—	—	2	2	2	2	2837 285
	Htr. Hose to Valve Cover		1	—	1	—	—	—	—	—	—	—	—	3441 036
	Evap. Top Cover to Hsg. Mtg.		1	—	1	—	—	—	—	—	—	—	—	271 025
	Evap. Unit to Htr. Unit Mtg.		1	—	1	—	—	—	—	—	—	—	—	271 025
24-28-73	DUCTS													
	Defroster		1	—	1	—	—	—	—	—	—	—	—	2837 810
	Air Outlet Partial		1	—	1	—	—	—	—	—	—	—	—	2837 062
	Center Air Outlet and Rt. S/Cooler		—	1	—	—	—	—	—	—	—	—	—	2936 842
	Lt.		—	1	—	—	—	—	—	—	—	—	—	2936 839
	Connector Spotcooler Tube Lt. 70		—	—	—	1	1	—	—	—	—	—	—	2837 555
	Spotcooler Rt. 70		—	—	—	1	1	—	—	—	—	—	—	3441 154
	Center Air Outlet, Fast Back Only 70		—	—	—	—	1	—	—	—	—	—	—	2837 652
	Except Fast Back 70		—	—	—	1	1	—	—	—	—	—	—	2837 579
	F/Air Inlet 70		—	—	—	1	1	—	—	—	—	—	—	2607 029
	A/C, Htr. Ctr. and Rt. Air Outlet 71		—	—	—	1	1	—	—	—	—	—	—	3441 388
	Spotcooler Lt. 71		—	—	—	1	1	—	—	—	—	—	—	3441 698
	Spotcooler Upper Lt. 70		—	—	—	—	—	1	—	—	—	—	—	2936 199
	Upper Lt. 70		—	—	—	—	—	—	1	—	—	—	—	2936 061
	Lower Lt. 70		—	—	—	—	—	—	1	—	—	—	—	2936 195
	Lower Lt. 70		—	—	—	—	—	—	—	1	—	—	—	2936 303
	Spotcooler Lt. Up to April, 1971		—	—	—	—	—	1	1	—	—	—	—	3441 999
	Lt. After April 1971		—	—	—	—	—	1	1	—	—	—	—	3502 163
	Rt. 71		—	—	—	—	—	1	1	—	—	—	—	2936 198
	Rt. 70		—	—	—	—	—	1	—	—	—	—	—	2936 198
	Rt. 70		—	—	—	—	—	—	1	—	—	—	—	2936 302
	Center Air Outlet 70		—	—	—	—	—	1	—	—	—	—	—	2936 308
	Up to Jan. 1970		—	—	—	—	—	—	1	—	—	—	—	2936 309
	After Jan. 1970		—	—	—	—	—	—	1	—	—	—	—	3441 606
	Up. to Jan. 1970 71		—	—	—	—	—	1	1	—	—	—	—	2936 308
	After Jan. 1970 71		—	—	—	—	—	1	1	—	—	—	—	3441 605
	Spotcooler, Connector Ctr. and Lt.		—	—	—	—	—	1	1	—	—	—	—	2936 342
	A/C and Htr. or A.T.C.													
	Spotcooler Rt. 71		—	—	—	—	—	—	—	1	1	1	1	3441 856
	Lt. 71		—	—	—	—	—	—	—	1	1	1	1	3441 512
	Spotcooler Center		—	—	—	—	—	—	—	1	1	1	1	2936 327
	Rt.		—	—	—	—	—	—	—	1	1	1	1	2936 324
	Lt. Up to Jan. 1970 70		—	—	—	—	—	—	—	1	1	1	1	2936 330
	Lt. After Jan. 1970 70		—	—	—	—	—	—	—	1	1	1	1	3941 508
	Defroster 71		—	—	—	1	1	—	—	—	—	—	—	3441 358
	Defroster		—	—	—	—	—	1	1	—	—	—	—	= 2936 138
	Defroster		—	—	—	—	—	—	—	1	1	1	1	= 2936 139
	Center Air Outlet 70		—	—	—	—	—	—	—	1	1	1	—	2936 380
	Ctr. Air Outlet 71		—	—	—	—	—	—	—	1	1	1	—	3441 350
	70		—	—	—	—	—	—	—	—	—	—	1	2936 320
	Ctr. Air Outlet 71		—	—	—	—	—	—	—	—	—	—	1	3441 337
NOTE: For Further Information See P.T.C. 1-48-141, Flex Tubes See 24-28-24														
24-28-78	AIR OUTLET, LOUVER, SPOTCOOLER and HOUSING													
	Louver and Housing,													
	Evap. Air Outlet Chrome Rt. 70		1	—	1	—	—	—	—	—	—	—	—	2837 836
	Chrome Lt. 70		1	—	1	—	—	—	—	—	—	—	—	2837 837
	Chrome Ctr. 70		1	—	1	—	—	—	—	—	—	—	—	2837 837
	Black Plastic Rt.		1	—	1	—	—	—	—	—	—	—	—	3441 487
	Black Plastic Lt.		1	—	1	—	—	—	—	—	—	—	—	3441 487
	Black Plastic Ctr.		1	—	1	—	—	—	—	—	—	—	—	3441 487

CARLINES

J - Challenger  
B - BarracudaV - Valiant  
L - DartR - Belvedere - Satellite  
W - Coronet - ChargerP - Plymouth  
D - DodgeC - Chrysler  
Y - Imperial

AR Indicates use as required.

# Indicates parts not listed in any previous parts book.

Numerals in parentheses ( ) refer to notes.

★ Indicates change or addition.

Printed in U.S.A.  
January 1972

CODE	PART NAME	ENG. TYPE OR CU.IN.	V	B	L	R	W	P	D	C	C	C	Y	PART NUMBER
			1-2	1-2	1-2	1-2	1-2	1-2	1-2	1	2	3	1	
<b>24-28-0 EVAPORATOR Cont'd.</b>														
24-28-78	AIR OUTLET Cont'd.													
	Spotcooler	Blue Rt. 70	—	1	—	—	—	—	—	—	—	—	—	4226 FB5
		Red Rt. 70	—	1	—	—	—	—	—	—	—	—	—	4226 FE5
		Green Rt. 70	—	1	—	—	—	—	—	—	—	—	—	4226 FF8
		Burnt Orange Rt. 70	—	1	—	—	—	—	—	—	—	—	—	4226 FK5
		Tan Rt. 70	—	1	—	—	—	—	—	—	—	—	—	4226 FT4
		Black Rt. 70	—	1	—	—	—	—	—	—	—	—	—	4226 FX9
		Blue Brite Rt. 71	—	1	—	—	—	—	—	—	—	—	—	4226 GB7
		Green Dark Rt. 71	—	1	—	—	—	—	—	—	—	—	—	4226 GF7
		Saddle Dark Rt. 71	—	1	—	—	—	—	—	—	—	—	—	4226 GT6
		Gold Rt. 71	—	1	—	—	—	—	—	—	—	—	—	4226 GY6
		Black Rt. 71	—	1	—	—	—	—	—	—	—	—	—	4226 GX9
	w/out Rallye Inst. Pnl. "B" Only	Lt. 70	—	1	—	—	—	—	—	—	—	—	—	2936 824
	w/out Rallye Inst. Pnl. "J" Only	Lt. 70	—	1	—	—	—	—	—	—	—	—	—	2936 825
	w/Rallye Inst. Pnl.	Lt.	—	1	—	—	—	—	—	—	—	—	—	2936 823
	w/o Rallye Inst. Pnl.	Lt. 71	—	1	—	—	—	—	—	—	—	—	—	2936 824
	Louver, Spotcooler	Lt.	—	1	—	—	—	—	—	—	—	—	—	2936 832
		Ctr. 70	—	2	—	—	—	—	—	—	—	—	—	2936 847
		Ctr. 71	—	2	—	—	—	—	—	—	—	—	—	3441 786
	Air Outlet	Blue Ctr. 70	—	1	—	—	—	—	—	—	—	—	—	4225 FB5
		Red Ctr. 70	—	1	—	—	—	—	—	—	—	—	—	4225 FE5
		Green Ctr. 70	—	1	—	—	—	—	—	—	—	—	—	4225 FF8
		Burnt Orange Ctr. 70	—	1	—	—	—	—	—	—	—	—	—	4225 FK5
		Tan Ctr. 70	—	1	—	—	—	—	—	—	—	—	—	4225 FT4
		Black Ctr. 70	—	1	—	—	—	—	—	—	—	—	—	4225 FX9
		Blue Ctr. 71	—	1	—	—	—	—	—	—	—	—	—	4225 GB7
		Green Dark Ctr. 71	—	1	—	—	—	—	—	—	—	—	—	4225 GF7
		Saddle Dark Ctr. 71	—	1	—	—	—	—	—	—	—	—	—	4225 GT6
		Gold Ctr. 71	—	1	—	—	—	—	—	—	—	—	—	4225 GY6
		Black Ctr. 71	—	1	—	—	—	—	—	—	—	—	—	4225 GX9
	Spotcooler	Rt. 70	—	—	—	1	1	—	—	—	—	—	—	3441 246
		Lt. 70	—	—	—	1	1	—	—	—	—	—	—	3441 247
	Spotcooler	Lt. 71	—	—	—	1	1	—	—	—	—	—	—	3441 362
	Air Outlet, Black Ctr. and Rt.	71	—	—	—	1	1	—	—	—	—	—	—	≠ 3502 005
	Air Outlet, Wood Grain Ctr. and Rt.	71	—	—	—	1	1	—	—	—	—	—	—	3441 439
	Louver, Air Outlet and Spotcooler	Ctr. 71	—	—	—	1	1	—	—	—	—	—	—	2837 778
	Spotcooler	Blue Rt. 70	—	—	—	—	—	1	—	—	—	—	—	4207 EB7
		Green Rt. 70	—	—	—	—	—	1	—	—	—	—	—	4207 EF8
		Burnt Orange Rt. 70	—	—	—	—	—	1	—	—	—	—	—	4207 FK5
		Tan Rt. 70	—	—	—	—	—	1	—	—	—	—	—	4207 FT4
		Black Rt. 70	—	—	—	—	—	1	—	—	—	—	—	4207 EX9
		Gold Rt. 70	—	—	—	—	—	1	—	—	—	—	—	4207 FY4
		Blue Rt. 71	—	—	—	—	—	1	1	—	—	—	—	4207 GB7
		Russet Rt. 71	—	—	—	—	—	1	1	—	—	—	—	4207 GE9
		Green Dark Rt. 71	—	—	—	—	—	1	1	—	—	—	—	4207 GF7
		Saddle Dark Rt. 71	—	—	—	—	—	1	1	—	—	—	—	4207 GT6
		Black Rt. 71	—	—	—	—	—	1	1	—	—	—	—	4207 GX9
		Gold Rt. 71	—	—	—	—	—	1	1	—	—	—	—	4207 GY6
		Gun Metal Rt. 71	—	—	—	—	—	1	1	—	—	—	—	4207 GA6
		Lt. 70	—	—	—	—	—	1	—	—	—	—	—	2936 149
		Lt. 71	—	—	—	—	—	1	1	—	—	—	—	3441 851
	Air Outlet	Blue Ctr. 70	—	—	—	—	—	1	—	—	—	—	—	4299 EB7
		Green Ctr. 70	—	—	—	—	—	1	—	—	—	—	—	4299 EF8
		Burnt Orange Ctr. 70	—	—	—	—	—	1	—	—	—	—	—	4299 FK5
		Tan Ctr. 70	—	—	—	—	—	1	—	—	—	—	—	4299 FT4
		Black Ctr. 70	—	—	—	—	—	1	—	—	—	—	—	4299 EX9
		Gold Ctr. 70	—	—	—	—	—	1	—	—	—	—	—	4299 FY4
		Blue Ctr. 71	—	—	—	—	—	1	1	—	—	—	—	4298 GB7
		Russet Ctr. 71	—	—	—	—	—	1	1	—	—	—	—	4298 GE9

CARLINES J - Challenger B - Barracuda V - Valiant L - Dart R - Belvedere - Satellite W - Coronet - Charger P - Plymouth D - Dodge C - Chrysler Y - Imperial

AR Indicates use as required. Numerals in parentheses ( ) refer to notes. Printed in U.S.A. January 1972  
 # Indicates parts not listed in any previous parts book. ★ Indicates change or addition.

CODE	PART NAME	ENG. TYPE OR CU.IN.	V	B	L	R	W	P	D	C	C	C	Y	PART NUMBER
			1-2	1-2	1-2	1-2	1-2	1-2	1-2	1	2	3	1	
<b>24-28-0 EVAPORATOR Cont'd.</b>														
24-28-78	AIR OUTLET Cont'd.													
		Green Dark Ctr. 71	—	—	—	—	—	—	1	1	—	—	—	4298 GF7
		Saddle Dark Ctr. 71	—	—	—	—	—	—	1	1	—	—	—	4298 GT6
		Black Ctr. 71	—	—	—	—	—	—	1	1	—	—	—	4298 GX9
		Gold Ctr. 71	—	—	—	—	—	—	1	1	—	—	—	4298 GY6
		Gun Metal Ctr. 71	—	—	—	—	—	—	1	1	—	—	—	4298 GA6
	Air Outlet	Ctr.	—	—	—	—	—	—	—	1	—	—	—	2936 191
	Spotcooler	Rt.	—	—	—	—	—	—	—	1	—	—	—	2936 156
		Lt.	—	—	—	—	—	—	—	1	—	—	—	2936 157
	Spotcooler, Rt. and Lt.	Blue 70	—	—	—	—	—	—	—	2	2	2	2	4411 FB7
		Green 70	—	—	—	—	—	—	—	2	2	2	2	4411 EF8
		Teal 70	—	—	—	—	—	—	—	2	2	2	2	4411 FP6
		Tan, Light 70	—	—	—	—	—	—	—	2	2	2	2	4411 FT4
		Tan, Dark 70	—	—	—	—	—	—	—	2	2	2	2	4411 FT8
		Burgundy 70	—	—	—	—	—	—	—	2	2	2	2	4411 EM9
		Red 70	—	—	—	—	—	—	—	2	2	2	2	4411 FR9
		Black	—	—	—	—	—	—	—	2	2	2	2	4411 EX9
		Gold, Light 70	—	—	—	—	—	—	—	2	2	2	2	4411 FY4
		Gold, Dark 70	—	—	—	—	—	—	—	2	2	2	2	4411 EY8
		Gun Metal 71	—	—	—	—	—	—	—	2	2	2	2	4411 GA6
		Blue Dark 71	—	—	—	—	—	—	—	2	2	2	2	4411 GB7
		Russet 71	—	—	—	—	—	—	—	2	2	2	2	4411 GE9
		Green Dark 71	—	—	—	—	—	—	—	2	2	2	2	4411 GF7
		Saddle Dark 71	—	—	—	—	—	—	—	2	2	2	2	4411 GT6
		Gold 71	—	—	—	—	—	—	—	2	2	2	2	4411 GY6
		Blue Dark 71	—	—	—	—	—	—	—	—	—	—	2	4411 GB9
		Burgundy 71	—	—	—	—	—	—	—	—	—	—	2	4411 GM9
		Black 71	—	—	—	—	—	—	—	2	2	2	2	4411 EX9
		Ctr. 70	—	—	—	—	—	—	—	1	1	1	—	2936 372
		Ctr. 71	—	—	—	—	—	—	—	1	1	1	—	3441 346
		Ctr. 70	—	—	—	—	—	—	—	—	—	—	1	2936 314
		Ctr. 71	—	—	—	—	—	—	—	—	—	—	1	3441 333
	Air Outlet, Rr. Evap.	Rt. 70	—	—	—	—	—	—	—	—	—	—	1	4468 DX9
		Lt. 70	—	—	—	—	—	—	—	—	—	—	1	4469 DX9
		Gun Metal 71	—	—	—	—	—	—	—	—	—	—	—	4468-9 GA6
		Blue Med. 71	—	—	—	—	—	—	—	—	—	—	1	4468-9 GB7
		Blue Dark 71	—	—	—	—	—	—	—	—	—	—	1	4468-9 GB9
		Russet 71	—	—	—	—	—	—	—	—	—	—	1	4468-9 GE9
		Green Dark 71	—	—	—	—	—	—	—	—	—	—	1	4468-9 GF7
		Burgundy 71	—	—	—	—	—	—	—	—	—	—	1	4468-9 GM9
		Saddle Dark 71	—	—	—	—	—	—	—	—	—	—	1	4468-9 GT6
		Black 71	—	—	—	—	—	—	—	—	—	—	1	4468-9 GX9
		Gold 71	—	—	—	—	—	—	—	—	—	—	1	4468-9 GY6
	LOUVER, Roof Unit Air Outlet		—	—	—	—	—	—	4	4	4	4	4	2521 635
24-28-84	ADAPTER													
		Rr. Evap. Air Inlet Conn. Reinf.	—	—	—	—	—	—	—	—	—	—	AR	2837 690
		Rr. Evap. Air Inlet and Compartment	—	—	—	—	—	—	—	—	—	—	AR	2485 540
		Speaker	—	—	—	—	—	—	—	—	—	—	AR	2485 540
24-28-90	DOOR and SEAL													
		A/Cond. Outlet 70	—	—	—	1	1	—	—	—	—	—	—	2521 126
		Floor Heat 70	—	—	—	1	1	—	—	—	—	—	—	2521 130
		NOTE: For Further Information See P.T.C. 1-48-365												
24-28-92	SEAL													
		Unit Mtg. at Tube Outlets	—	1	—	1	1	—	—	—	—	—	—	2936 933
		Dist. Hsg. to Duct	—	1	—	—	—	—	—	—	—	—	—	2936 503
		Dist. Hsg. to Ctr. Outlet Duct	—	—	—	—	—	1	1	1	1	1	1	2936 270
		A/C and Htr. or A.T.C. Outlet Duct	—	—	—	—	—	1	1	—	—	—	—	2936 312
24-28-93	CONNECTOR and REINFORCEMENT													
		Rr. Evap. Air Inlet Shelf Rt.	—	—	—	—	—	—	—	—	—	—	AR	2485 603
24-28-95	NUT, Grille Mtg., In Car Sensor, w/A.T.C.70													
			—	—	—	—	—	2	2	—	—	—	—	1839 995
CARLINES	J - Challenger B - Barracuda	V - Valiant L - Dart	R - Belvedere - Satellite W - Coronet - Charger				P - Plymouth D - Dodge			C - Chrysler Y - Imperial				

AR Indicates use as required.

# Indicates parts not listed in any previous parts book.

Numerals in parentheses ( ) refer to notes.

★ Indicates change or addition.

Printed in U.S.A.  
January 1972



CODE	PART NAME	ENG. TYPE OR CU.IN.	V	B	L	R	W	P	D	C	C	C	Y	PART NUMBER
			1-2	1-2	1-2	1-2	1-2	1-2	1-2	1	2	3	1	
<b>24-28-0 EVAPORATOR Cont'd.</b>														
24-28-96	SEAL													
	F/Air and Recir. Hsg. to Scroll	70	—	—	—	1	1	—	—	—	—	—	—	2837 632
	Rear Hsg. to Dash Ext.													
	Up to Jan. 1, 1970	70	—	—	—	—	—	1	1	1	1	1	1	2936 003
	After Jan. 1, 1970		—	—	—	—	—	1	1	1	1	1	1	3441 295
	Recir. Hsg. to Plenum Ext.													
	Up to Jan. 1, 1970	70	—	—	—	—	—	1	1	1	1	1	1	2936 004
	After Jan. 1, 1970		—	—	—	—	—	1	1	1	1	1	1	3441 296
	Htr. Hsg. to Plenum		1	—	1	—	—	—	—	—	—	—	—	2277 669
	A/C and Unit Assy. Mtg. at Plenum		—	1	—	1	1	—	—	—	—	—	—	2607 312
24-28-99	LINKAGE													
	Door Control	70	—	—	—	1	1	—	—	—	—	—	—	2607 785
			—	—	—	—	—	1	1	1	1	1	1	2936 271
24-28-100	SHAFTS													
	Htr. Shut Off Door Lever to Adj. Nut		1	—	1	—	—	—	—	—	—	—	—	2521 571
	Adj. Nut to Crank		1	—	1	—	—	—	—	—	—	—	—	2521 572
	Htr. Recir. Door To Crank		1	—	1	—	—	—	—	—	—	—	—	2521 573
	w/Lever, Htr. Shut Off Door		1	—	1	—	—	—	—	—	—	—	—	2521 545
24-28-101	RETAINERS													
	Adj. Nut to Crank		2	—	2	—	—	—	—	—	—	—	—	2197 678
	Door Lever Shaft to Adj. Nut		2	—	2	—	—	—	—	—	—	—	—	2197 678
	Vacuum Actuator Rod		2	—	2	—	—	—	—	—	—	—	—	2197 678
	Recir. Door Shaft		2	—	2	—	—	—	—	—	—	—	—	2197 678
	Recir. Door Shaft to Crank		2	—	2	—	—	—	—	—	—	—	—	2197 678
	Vacuum Actuator Rod Inlet Door		2	—	2	—	—	—	—	—	—	—	—	2197 678
	Floor Air Door Mtg.	70	—	1	—	—	—	—	—	—	—	—	—	2197 678
24-28-104	KNOB, S/Cooler Shut Off Door	70	—	—	—	2	2	—	—	—	—	—	—	2837 933
	NOTE: For Further Information See P.T.C. 1-48-942													
24-28-107	PLATE, Evap. Air Outlet Trim													
	Up to May 1, 1970	70	2	—	2	—	—	—	—	—	—	—	—	2607 838
	After May 1, 1970		2	—	2	—	—	—	—	—	—	—	—	3441 496
24-28-108	SPRINGS													
	Floor Heat Door Lever		—	—	—	1	1	—	—	—	—	—	—	2521 701
	Door Over Center		—	—	—	1	1	—	—	—	—	—	—	2521 694
	F/Air and Recir. Door		—	—	—	1	1	—	—	—	—	—	—	2521 082
24-28-113	HOUSINGS													
	F/Air and Recirculating		—	—	—	1	1	—	—	—	—	—	—	2837 849
	Recir., Dual w/Front Htr.													
	Up to Jan. 1, 1970	70	—	—	—	—	—	1	1	1	1	1	—	2936 001
	After Jan. 1, 1970		—	—	—	—	—	1	1	1	1	1	1	3441 293
	After Feb. 1, 1971		—	—	—	—	—	1	1	1	1	1	1	3441 936
	Recir., w/out A.T.C.	70	—	—	—	—	—	1	1	1	1	1	1	2936 739
	Recir., w/A.T.C. Model F	70	—	—	—	—	—	1	1	1	1	1	1	3620 732
	Recir., w/A.T.C.		—	—	—	—	—	1	1	1	1	1	1	3441 294
24-28-115	COVER, Recirculating Hsg. and Linkage	70	—	—	1	1	—	—	—	—	—	—	—	2837 638
24-28-117	LEVER													
	Evap. Defroster Door Shaft		1	—	1	—	—	—	—	—	—	—	—	2521 629
	Evap. Air Inlet Door		1	—	1	—	—	—	—	—	—	—	—	2521 501
	Floor Heat Door Control	70	—	—	—	1	1	—	—	—	—	—	—	2521 712
	A/Cond. Door	70	—	—	—	—	—	1	1	1	1	1	1	3441 076
	A/Cond. Door Up to April 1971		—	—	—	—	—	1	1	1	1	1	1	3441 577
	After April 1971		—	—	—	—	—	1	1	1	1	1	1	3522 784
24-28-118	SPACER, Htr. Door Control Lever	70	—	—	—	1	1	—	—	—	—	—	—	2521 713
24-28-128	HOUSINGS, Engine Side													
	Up to April 1971		—	—	—	—	—	1	1	1	1	1	1	2936 288
	After April 1971		—	—	—	—	—	1	1	1	1	1	1	3502 040
24-28-138	L/PLATE A/C and Htr./Htr. Vent Door		1	—	1	—	—	—	—	—	—	—	—	2277 516
	NOTE: For Further Information See P.T.C. 1-48-125													
24-28-175	HOUSINGS													
	Roof Unit Blower	C.W.	—	—	—	—	—	2	2	2	2	2	—	1887 299
		C.C.W.	—	—	—	—	—	2	2	2	2	2	—	1887 300
CARLINES	J - Challenger B - Barracuda	V - Valiant L - Dart	R - Belvedere - Satellite W - Coronet - Charger	P - Plymouth D - Dodge	C - Chrysler Y - Imperial									

AR Indicates use as required.

# Indicates parts not listed in any previous parts book.

Numerals in parentheses ( ) refer to notes.

★ Indicates change or addition.

CODE	PART NAME	ENG. TYPE OR CU.IN.	V	B	L	R	W	P	D	C	C	C	Y	PART NUMBER
			1-2	1-2	1-2	1-2	1-2	1-2	1-2	1	2	3	1	
<b>24-28-0 EVAPORATOR Cont'd.</b>														
24-28-195	MOTOR, Blower	70	1	—	1	—	—	—	—	—	—	—	—	2932 709
		71	1	—	1	—	—	—	—	—	—	—	—	3420 950
			—	1	—	1	1	—	—	—	—	—	—	2936 687
		70	—	—	—	1	1	—	—	—	—	—	—	2932 709
	Roof Unit, Rt. and Lt.		—	—	—	—	—	1	1	1	1	1	1	3514 304
	Rear Evap.		—	—	—	—	—	2	2	2	2	2	—	1886 266
	NOTE: For Further Information See P.T.C. 1-48-599		—	—	—	—	—	—	—	—	—	1	1	2485 580
24-28-200	SPACER, Air Outlet Duct Mtg. to Panel													
	Up to Jan. 1, 1970	70	1	—	—	—	—	—	—	—	—	—	—	2607 837
	After Jan. 1, 1970	70	1	—	1	—	—	—	—	—	—	—	—	3441 495
24-28-201	MOUNT, Blower Motor		3	—	3	3	3	3	3	3	3	3	3	2277 596
24-28-203	RESISTOR, Blower Motor		1	—	1	—	—	—	—	—	—	—	—	2837 805
	Rear Evap. Motor		—	1	—	1	1	—	—	—	—	—	—	3441 175
			—	—	—	—	—	—	—	—	—	—	1	2485 593
24-28-204	GASKET, Rr. Evap. Blower Motor Mtg.		—	—	—	—	—	—	—	—	—	—	2	2076 088
	Htr. Blower Mtr. Mtg.		—	—	—	AR	AR	—	—	—	—	—	—	2076 088
24-28-207	PLATE, Blower Motor Mtg.		1	—	1	—	—	—	—	—	—	—	—	2521 144
			—	1	—	1	1	—	—	—	—	—	—	3441 230
			1	—	1	1	1	—	—	—	—	—	—	2521 144
			—	—	—	—	—	1	1	1	1	1	1	2936 214
24-28-208	RETAINER, Motor Mtg. Plate Seal		1	—	1	1	1	1	1	1	1	1	1	2521 231
24-28-210	WHEEL, Blower Motor		—	1	—	1	1	1	1	1	1	1	1	2808 880
			1	—	1	—	—	—	—	—	—	—	—	2808 772
	Roof Unit	C.W.	—	—	—	—	—	1	1	1	1	1	—	1886 265
		C.C.W.	—	—	—	—	—	1	1	1	1	1	—	1886 263
	Rr. Evap.	Rt.	—	—	—	—	—	—	—	—	—	—	1	2485 591
		Lt.	—	—	—	—	—	—	—	—	—	—	1	2277 597
	Clamp, Blower Wheel		—	—	—	1	1	—	—	—	—	—	—	2837 680
	Blower Wheel Mtg.		—	1	—	—	—	—	—	—	—	—	—	2837 680
	NOTE: For Further Information See P.T.C. 1-48-46													
24-28-211	SEAL													
	Blower Motor Retainer to Mtg. Plate		1	1	1	1	1	1	1	1	1	1	1	2837 291
	Hsg. Mtg. to Unit, Bottom		—	1	—	—	1	1	—	—	—	—	—	3441 031
	Blower Motor Mtg. to Unit		—	1	—	—	1	1	—	—	—	—	—	2936 507
	A/C and Htr. Unit Mtg. at Blwr. Mtg.		—	1	—	1	1	—	—	—	—	—	—	2936 930
	Plate to Hsg.		—	—	—	—	—	1	1	1	1	1	1	2936 215
24-28-220	COIL, Evaporator		1	—	1	—	—	—	—	—	—	—	—	2936 897
		71	—	1	—	—	—	—	—	—	—	—	—	3441 578
		70	—	—	—	1	1	—	—	—	—	—	—	3441 578
			—	—	—	1	1	—	—	—	—	—	—	2919 269
	Roof Unit Evap.		—	—	—	—	—	1	1	1	1	1	1	2923 914
	Roof Unit Evap. w/Blower		—	—	—	—	—	1	1	1	1	1	—	2936 424
	Rear Evap.		—	—	—	—	—	—	—	—	—	—	1	2936 421
			—	—	—	—	—	—	—	—	—	—	—	2936 584
24-28-225	SEAL, Evap. Coil	Top Side	—	—	—	—	—	1	1	1	1	1	1	2936 203
			—	—	—	—	—	1	1	1	1	1	1	2936 204
24-28-300	VALVE, Expansion		1	1	1	1	1	1	1	1	1	1	1	2932 843
	Roof Evap. Unit		—	—	—	—	—	1	1	1	1	1	—	2936 438
	Rear Evap.		—	—	—	—	—	—	—	—	—	—	1	2932 842
24-28-302	ELBOW, Exp. Valve to Dash		1	—	1	—	—	—	—	—	—	—	—	2936 783
24-28-318	CONNECTOR and TEES													
	Tee, Vacuum Hose		1	—	1	1	1	—	—	—	—	—	—	1886 109
	Tee, Vacuum Hose Rr.		—	—	—	—	—	—	—	1	1	1	1	1886 109
			—	2	—	—	—	—	—	—	—	—	—	3441 425
	Tee, Conn. Vac. Hose		—	1	—	—	—	—	—	—	—	—	—	3441 425
			—	—	—	—	—	1	1	1	1	1	1	3441 862
	A/Cond. and Htr. Hose	70	—	—	—	—	—	1	1	1	1	1	1	3441 235
	Connector		—	—	—	AR	AR	AR	AR	AR	AR	AR	AR	3441 425

CARLINES

J - Challenger  
B - BarracudaV - Valiant  
L - DartR - Belvedere - Satellite  
W - Coronet - ChargerP - Plymouth  
D - DodgeC - Chrysler  
Y - Imperial

AR Indicates use as required.

# Indicates parts not listed in any previous parts book.

Numerals in parentheses ( ) refer to notes.

★ Indicates change or addition.

Printed in U.S.A.  
January 1972

CODE	PART NAME	ENG. TYPE OR CU.IN.	V	B	L	R	W	P	D	C	C	C	Y	PART NUMBER
			1-2	1-2	1-2	1-2	1-2	1-2	1-2	1	2	3	1	
<b>24-28-0 EVAPORATOR Cont'd.</b>														
24-28-318	CONNECTOR and TEES Cont'd.													
	Tee, A/C and Htr. Vac. Resr. Hose W/Trail Tow.		—	—	—	—	—	1	1	1	1	1	—	3441 425
	Connector Vacuum Hose Reducer A.T.C.	71	—	—	—	—	—	—	—	1	1	1	1	3441 743
	Vacuum Hose, 3 Port		—	—	—	—	—	1	1	1	1	1	1	2936 748
	Vacuum Hose Ext. A/C and Htr. Control	71	—	—	—	1	1	—	—	—	—	—	—	3431 297
	Tee, Connector	70	—	—	—	—	—	3	3	3	3	3	—	2837 877
	Tee, A/C and Htr. A.T.C.	71	—	—	—	—	—	—	—	1	1	1	1	3441 734
	Connector, A/C and Htr. Vac. Hose A.T.C.		1	1	1	1	1	—	—	—	—	—	—	1886 110
	Recirc. Vac. Ext. Hose A.T.C.		—	—	—	—	—	—	—	1	1	1	1	1886 110
NOTE: For Further Information See P.T.C. 1-48-280														
24-28-319	WRENCH, Suction Fitting		—	1	—	1	1	—	—	—	—	—	—	3441 446
		70	—	—	—	—	—	1	1	1	1	1	1	3441 447
24-28-326	SEAL, Hose and Tube "O" Ring	3/8" O.D.	AR	AR	AR	AR	AR	AR	AR	AR	AR	AR	AR	2219 383
		1/4" O.D.	AR	AR	AR	AR	AR	AR	AR	AR	AR	AR	AR	2277 190
		1/2" O.D.	AR	AR	AR	AR	AR	AR	AR	AR	AR	AR	AR	2219 384
		5/8" O.D.	AR	AR	AR	AR	AR	AR	AR	AR	AR	AR	AR	2219 385
		3/4" O.D.	AR	AR	AR	AR	AR	AR	AR	AR	AR	AR	AR	2521 172
	Rec. Drier. Cut Off Switch	71	1	1	1	1	1	1	1	1	1	1	1	3441 105
	Discharge Muffler to Compressor		—	1	—	—	—	—	—	—	—	—	—	2936 715
	Discharge Line Mtg. Flange		—	—	—	1	1	1	1	1	1	1	1	2936 715
	Hsg. and Door Duct	70	—	—	—	1	1	—	—	—	—	—	—	2837 591
	Seal Discharge Line to Compressor		1	1	1	1	1	1	1	1	1	1	1	3441 513
	Roof Unit Liq. and Suction Tube Mtg. Plate to U/Body	71	—	—	—	—	—	1	1	1	1	1	—	3441 812
24-28-334	HOUSINGS		—	1	—	—	—	—	—	—	—	—	—	2936 599
	A/Cond. Distribution	70	—	—	—	1	1	—	—	—	—	—	—	2837 590
			—	—	—	1	1	—	—	—	—	—	—	3441 382
	w/Doors	70	—	—	—	1	1	—	—	—	—	—	—	2837 587
		70	—	—	—	—	—	1	1	1	1	1	1	2936 267
		71	—	—	—	—	—	1	1	1	1	1	1	3441 724
24-28-335	COVER, Floor Heat Distribution		—	—	—	—	—	1	1	1	1	1	1	2936 263
24-28-336	DOOR, Distribution Housing	Rt. 70	—	—	—	1	1	—	—	—	—	—	—	2521 440
		Lt. 70	—	—	—	1	1	—	—	—	—	—	—	2521 441
24-28-338	SPRING, Distribution Hsg. Retainer	70	—	—	—	2	2	—	—	—	—	—	—	2521 439
24-28-339	GASKET, Dist. Hsg. to Rear Hsg.		—	—	—	—	—	1	1	1	1	1	1	2936 266
24-28-341	ROD, F/Air Inlet Duct Mtg. to Plenum	70	—	—	—	2	2	—	—	—	—	—	—	2607 004
24-28-380	BRACKET, Ctr. and Rt. S/Cooler Duct Mtg.		—	1	—	—	—	—	—	—	—	—	—	2936 844
24-28-383	DAMPER, A/Cond. and Htr. Defroster	70	—	—	—	2	2	—	—	—	—	—	—	2521 123
24-28-388	RETAINER, Rt. S/Cooler Shut Off Door Link		—	—	—	—	—	1	—	—	—	—	—	2197 678
24-28-392	RETAINER		AR	AR	AR	AR	AR	AR	AR	AR	AR	AR	AR	2197 678
	A/C Temp. Control Cable to Control A/C., Htr. Evap. A/Inlet Dr. Vac. Actr. Rod		1	—	1	—	—	—	—	—	—	—	—	2197 678
	A/C., Htr. Evap. Temp. Control Cable to Switch		2	—	2	—	—	—	—	—	—	—	—	2197 678
	Htr. Vent Door		1	—	1	—	—	—	—	—	—	—	—	2197 678
	A.T.C. Thumbweel		—	—	—	—	—	—	—	1	1	1	1	2197 678
	A/C., Htr. Rt. S/Cooler Shut off Link		—	—	—	—	—	1	1	—	—	—	—	2197 678
24-28-399	SHAFTS													
	Defroster Door	70	—	—	—	1	1	—	—	—	—	—	—	2607 783
	A/Cond. Door	70	—	—	—	1	1	—	—	—	—	—	—	2521 099
	Floor Heat Door	70	—	—	—	1	1	—	—	—	—	—	—	2521 108
NOTE: For Further Information See P.T.C. 1-48-356														
24-28-403	HANDLE, S/Cooler Damper Shaft	70	—	—	—	AR	AR	—	—	—	—	—	—	2607 517

CARLINES J - Challenger V - Valiant R - Belvedere - Satellite P - Plymouth C - Chrysler  
 B - Barracuda L - Dart W - Coronet - Charger D - Dodge Y - Imperial

AR Indicates use as required. Numerals in parentheses ( ) refer to notes. Printed in U.S.A. January 1972  
 # Indicates parts not listed in any previous parts book. ★ Indicates change or addition.

CODE	PART NAME	ENG. TYPE OR CU.IN.	V	B	L	R	W	P	D	C	C	C	Y	PART NUMBER
			1-2	1-2	1-2	1-2	1-2	1-2	1-2	1	2	3	1	
<b>24-28-0 EVAPORATOR Cont'd.</b>														
24-28-405	CONNECTORS													
	Vacuum Hose	70	1	1	1	1	1	—	—	—	—	—	—	1886 110
	S/Cooler Tube	Lt. 70	—	—	—	1	1	—	—	—	—	—	—	2837 555
	Liq. Tube to Cond.	71	—	1	—	1	1	—	—	—	—	—	—	# 3441 933
24-28-406	WASHER, Rt. S/Cooler Shut Off Door Link		—	—	—	—	—	1	1	—	—	—	—	2936 391
<b>24-29-0 ACTUATOR</b>														
24-29-1	ACTUATORS, Vacuum													
	Water Valve		1	—	1	—	—	—	—	—	—	—	—	3441 215
	Evap. Defroster Door		1	—	1	—	—	—	—	—	—	—	—	3441 219
	Evap. Air Inlet Door	70	1	—	1	—	—	—	—	—	—	—	—	3441 221
	Evap. Air Inlet Door	71	1	—	1	—	—	—	—	—	—	—	—	3441 923
	Htr. Shut Off Door		1	—	1	—	—	—	—	—	—	—	—	3441 223
	A/Cond. Door and Htr.		—	1	—	1	1	—	—	—	—	—	—	2936 962
	F/Air Door		—	1	—	1	1	—	—	—	—	—	—	2936 952
	Defroster Door		—	1	—	1	1	—	—	—	—	—	—	3441 323
	Passenger Door		—	1	—	1	1	—	—	—	—	—	—	3441 324
	Htr. Door	70	—	—	—	1	1	—	—	—	—	—	—	3441 212
	A/Cond. Door	70	—	—	—	1	1	—	—	—	—	—	—	2837 891
	F/Air Door	70	—	—	—	1	1	—	—	—	—	—	—	3441 214
	Htr. Door		—	—	—	—	1	1	1	1	1	1	1	3441 206
	Htr. Vent Door	71	—	—	—	—	—	1	1	1	1	1	—	3441 686
	A/Cond. Door		—	—	—	—	—	1	1	1	1	1	1	3441 208
	Recirculating, w/Out A.T.C.	70	—	—	—	—	—	1	1	1	1	1	1	3441 314
	Up to April 1971		—	—	—	—	—	1	1	1	1	1	—	3441 314
	After April 1971		—	—	—	—	—	1	1	1	1	1	1	= 3441 938
	Recirculating, w/A.T.C.	70	—	—	—	—	—	1	1	1	1	1	1	3441 203
	w/A.T.C.		—	—	—	—	—	1	1	1	1	1	1	3441 315
	Htr. Defroster Door	70	—	—	—	—	—	—	1	1	1	1	1	3441 217
24-29-3	BRACKET'S													
	Recirculating Actuator													
	Mtg. w/out A.T.C.	70	—	—	—	—	—	1	1	1	1	1	—	2936 745
	Mtg. w/Out A.T.C.		—	—	—	—	—	1	1	1	1	1	1	2936 015
	Mtg. w/A.T.C.	70	—	—	—	—	—	1	1	1	1	1	1	
	Recirculating Vacuum Switch													
	Mtg. w/A.T.C.	70	—	—	—	—	—	1	1	1	1	1	1	2936 017
	Recirculating Vac. Actuator Mtg.													
	w/A.T.C.	71	—	—	—	—	—	—	1	1	1	1	1	3441 309
24-29-6	BRACKET, Htr. or A.T.C. Actuator Mtg.		—	—	—	—	—	1	1	1	1	1	1	2936 237
24-29-9	PARTITION, A/Cond. and Htr. Defroster		—	1	—	1	1	—	—	—	—	—	—	2936 690

NOTES

CARLINES	J - Challenger B - Barracuda	V - Valiant L - Dart	R - Belvedere - Satellite W - Corone - Charger	P - Plymouth D - Dodge	C - Chrysler Y - Imperial
----------	---------------------------------	-------------------------	---	---------------------------	------------------------------

AR Indicates use as required.

# Indicates parts not listed in any previous parts book.

Numerals in parentheses ( ) refer to notes.

★ Indicates change or addition.

Printed in U.S.A.  
January 1972