

## GROUP 14

# FUEL SYSTEM (PUMP, CARBURETOR, TANK)

### CONTENTS

#### PART 1—WWC3 Series Carburetor

	Page		Page
Disassembling the Carburetor .....	5	Carburetor Adjustments .....	10
Inspection and Reassembly .....	7	Automatic Choke (Well Type) .....	14

#### PART 2—BBD Series Carburetor

Disassembling the Carburetor .....	16	Automatic Choke (Well Type) .....	23
Inspection and Reassembly .....	17	Closed Crankcase Vent System .....	23
Carburetor Adjustments .....	19	Throttle Linkage .....	23

#### PART 3—AFB Series Carburetor

Disassembling the Carburetor .....	26	Automatic Choke (Well Type) .....	35
Inspection and Reassembly .....	29	Closed Crankcase Vent System .....	36
Carburetor Adjustments .....	32	Throttle Linkage .....	36

#### PART 4—Firepower 390 FUEL AND INDUCTION SYSTEM

Intake Manifolds .....	38	Inspection and Reassembly .....	45
Throttle Linkage .....	41	Carburetor Adjustments .....	48
Disassembling the Carburetor (AFB) .....	43		

#### PART 5—Fuel Pump and Tank

Fuel Pump Operation .....	50	Fuel Tank—Removal .....	52
Testing the Fuel Pump .....	50		

#### PART 6—Service Diagnosis

Carburetor .....	55
------------------	----

### SPECIAL TOOLS

T109-22 .....	Bending Tool
T109-29 .....	Wire Gauge .020" Secondary Throttle Lever
T109-31 .....	1/4" Gauge, Choke Unloader
T109-31 .....	1/4" Gauge, Fast Idle Cam Positioning (T109-238, 1 1/4" Manual Trans.)
T109-32 .....	1 3/4" Gauge, Fast Idle Cam Positioning 1 3/4" Gauge, Unloader Adjustment
T109-36 .....	1/8" Gauge, Vacuum Kick Adjustment
T109-41 .....	Bending Tool (Fast Idle and Unloader)
T109-58 .....	Screw Driver Bit
T109-59 .....	Screw Driver Bit
T109-80 .....	Gauge, 3/8" Unloader
T109-106 .....	3/32" Gauge, Vacuum Kick Adjustment (Manual Trans.)
T109-39 .....	1 3/4" Gauge, Fast Idle Cam Positioning
T109-166 .....	1 1/4" Gauge, Vacuum Kick Adjustment (Auto. Trans.)
T109-173 .....	Main Metering Jet (Removal and Installation)
T109-213 .....	Bending Tool
T109-214 .....	Bending Tool
T109-282 .....	1/4" Gauge, Float
T109-287S .....	Elevating Legs
C-3400 .....	Repair Stand
73598 .....	Power Bypass Jet (Removal and Installation)
73605 .....	Bending Tool
73725 .....	3/32" Gauge, Float
No. 47 .....	3/4" Drill, Bowl Vent Valve

## SPECIFICATIONS

MAKE.....	Stromberg	Ball & Ball	Carter	Carter	Carter
TYPE.....	Dual Downdraft	Dual Downdraft	4 Barrel Downdraft	2-4 Barrel Downdraft	4 Barrel Downdraft
CARBURETOR MODEL.....	WWC3-244 Manual Trans.	WWC3-242 Auto. Trans.	BBD-3685S	AFB-3614S	AFB-3505S AFB-3615S AFB-3644S
ENGINE DISPLACEMENT (Cu. In.).....	361	361	383	413	413
CAR MODEL ENGINE APPLICATION.....	VC-1 with Firebolt 265	VC-2 with Firepower 305	VC-1 Police VC-2 Hi-Perf. with Firepower 360	VC-2 with Firepower 390	VC-3 with Firepower 340 VY-1 with Imperial V-8
BORE					
Primary.....	1 $\frac{1}{16}$ "	1 $\frac{1}{16}$ "	1 $\frac{1}{16}$ "	1 $\frac{1}{16}$ "	1 $\frac{1}{16}$ "
Secondary.....	—	—	—	1 $\frac{1}{16}$ "	1 $\frac{1}{16}$ "
MAIN VENTURI					
Primary.....	1 $\frac{3}{16}$ "	1 $\frac{3}{16}$ "	1 $\frac{3}{16}$ "	1 $\frac{3}{16}$ "	1 $\frac{3}{16}$ "
Secondary.....	—	—	—	1 $\frac{1}{16}$ "	1 $\frac{3}{16}$ "
MAIN METERING JET.....	Part No. 388186	—	.089"	.089"	.089"
Standard.....	.061"	.061"	#120-248	—	—
One Step Lean.....	.059"	.059"	#120-249	—	—
Two Steps Lean.....	.057"	.057"	#120-250	—	—
MAIN JET (Secondary).....	—	—	—	.067"	.082"
POWER JET.....	.028" x .055"	.028" x .055"	—	—	—
LOW SPEED JET (Primary).....	—	—	—	#65-.035"	#65-.035"
STEP UP WIRE DIAMETER					
(Standard).....	—	—	75-1598	—	—
(2 Stage).....	—	—	.031" x .026"	—	—
STEP UP ROD (2 Stages)					
Standard.....	—	—	—	16-217	16-118
(1 Size Lean).....	—	—	—	16-165	16-119
(2 Sizes Lean).....	—	—	—	16-159	16-50
					16-165 16-160 16-173

## SPECIFICATIONS— (Continued)

### ADJUSTMENTS

Accelerator Pump Travel.....	—	—	1" ± 1/64"	—	—	—
Accelerator Pump Travel (Blades Fully Closed)....	7/16"	7/16"	—	—	—	—
Accelerator Pump (Top of Plunger to Air horn)....	—	—	—	7/16"	7/16"	7/16"
Float Setting.....	3/32"	3/32"	1/4"	7/32"	9/32"	7/32"
Float Drop.....	—	—	—	3/4"	1/2"	3/4"
Bowl Vent Valve (Curb Idle).....	1/16"	1/16"	1/16"	—	—	—
Vacuum Kick (Drill Size).....	7/32"	1 1/4"	1 1/4"	1/8"	—	1/8"
Choke Unloader.....	1 3/4"	1 3/4"	1/4"	3/8"	—	3/8"
Idle Mixture Screws (Turns Open).....	1 1/2	1 1/2	3/4"	1-2	1-2	1-2
Idle Speed RPM (Curb Idle).....	500	500	500	500	700	500
(Air Conditioning on) RPM.....	500	500	500	500	500	500
Fast Idle Speed RPM.....	600	700	700	700	1400	700
Fast Idle Cam Position Adjustment.....	1 7/64"	1/4"	1 3/64"	1 3/64"	—	1 3/64"
Secondary Throttle Lever Adjustment.....	—	—	—	2 1/64"	2 9/64"	2 1/64"
Secondary Throttle Lockout Adjustment.....	—	—	—	.020"	.020"	.020"
Velocity Valve.....	—	—	—	—	Free	—

### CHOKE

Type.....	Well	Well	Well	Hand	Well
Control.....	Thermostatic Coil Spring	Thermostatic Coil Spring	Thermostatic Coil Spring	—	Thermostatic Coil Spring
Setting.....	1 Notch Rich	2 Notches Rich	On Index	—	2 Notches Rich

### FUEL PUMP

#### VC-1, VC-2, VC-3, VY-1

Make.....	Carter
Model.....	M-3672S
Type.....	Diaphragm
Number of Valves.....	2
Driven by.....	Camshaft
Pump Pressure.....	3 1/2 to 5 psi

**14-4 WWC3 CARBURETOR**

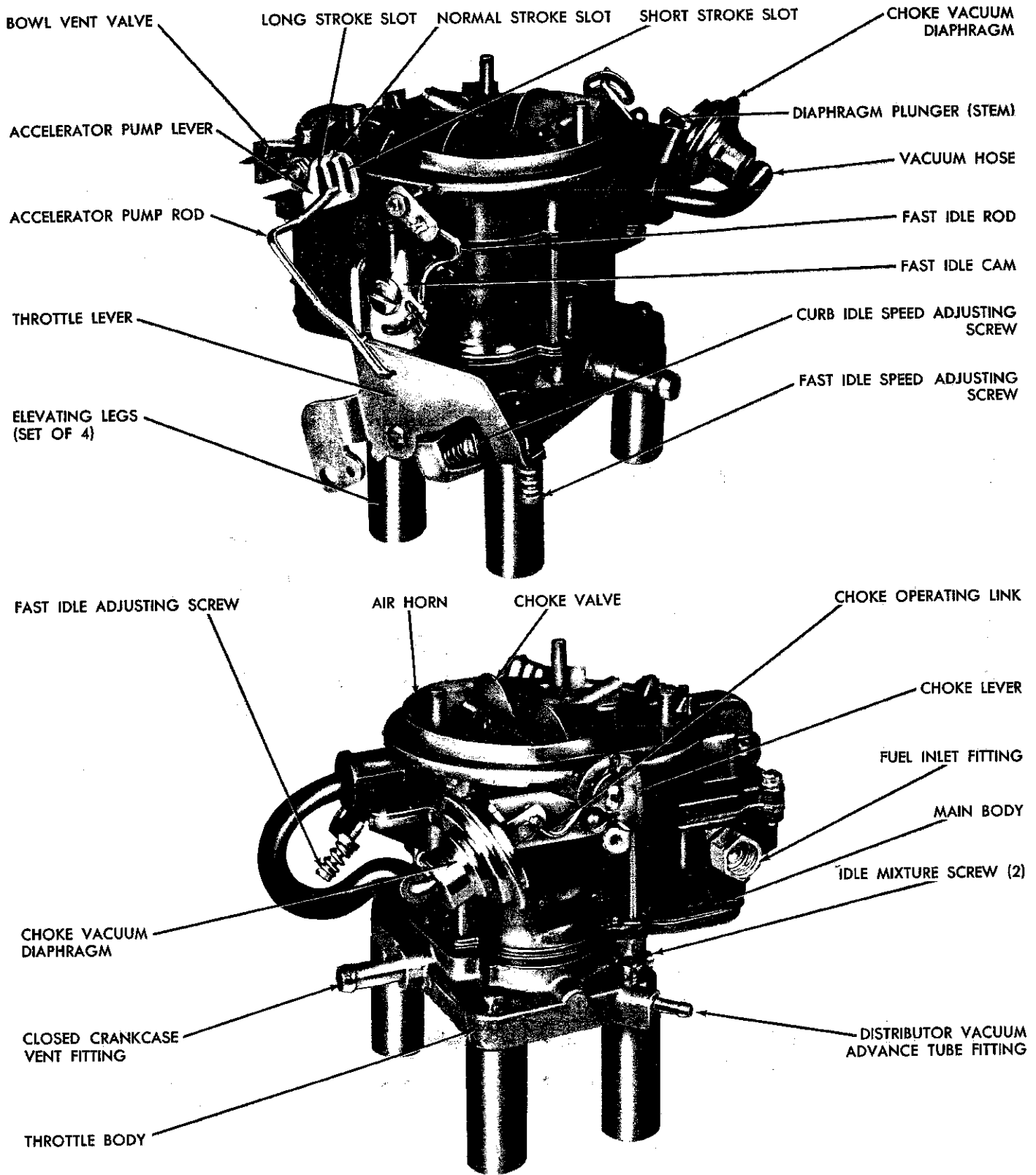

64x22'

**Fig. 1—Carburetor Assembly (WWC3 Series)**

# FUEL SYSTEM

## PART 1

### MODEL WWC3 STROMBERG CARBURETORS

The WWC3 Series Stromberg carburetor (Fig. 1) is a dual throat downdraft type, with each throat having its own idle system, main metering system and throttle valve. The idle and main metering systems are supplemented by the float system, the accelerating system and the power system.

The carburetor incorporates an idle system vent, operated from the throttle linkage, a double venturi cluster which in addition to the small venturi, also includes the discharge nozzles, the main discharge tubes and the idle tubes in a single assembly. Dirt, dust, water and gummy deposits are some of the main causes for improper carburetor operation. Proper cleaning, however, and the installation of new parts, where required, will return the carburetor to

its originally designed performance.

When overhauling the carburetor, several items of importance should be observed to assure a good job.

(1) All parts (except the diaphragm assembly) should be carefully cleaned in a suitable solvent, then inspected for damage or wear.

(2) Use air pressure only, to clean the various orifices and channels.

(3) Replace questionable parts with NEW ones. Always use a complete kit when overhauling the carburetor. Using the code number stamped on the air horn, adjacent to the fuel inlet, refer to the parts catalog and order the correct repair kit for the carburetor being worked on.

## SERVICE PROCEDURES

### 1. DISASSEMBLING THE CARBURETOR (Figs. 1 and 2)

(1) Install four elevating legs, Tool T109-287S, in the mounting flange holes in the throttle body. These legs are used to protect the throttle valves from damage and to provide a suitable base for working.

(2) Remove the hairpin clip that holds the pump rod in the center slot of the pump arm. Remove rod from slot and disengage from the throttle lever.

(3) Remove the hairpin clip that hold the fast idle rod in the fast idle cam. Disengage rod from cam, then rotate rod to disengage from choke lever.

(4) Remove the three short air horn attaching screws, then remove the two long air horn attaching screws. Install two short screws through the main body into the throttle body to hold the bodies together (Fig. 3).

(5) Remove the vacuum hose between the carburetor or air horn and the vacuum diaphragm.

(6) Remove the clip from the choke operating link and disengage the link from the diaphragm plunger (stem) and the choke lever. (Refer to Fig. 1.)

(7) Remove the vacuum diaphragm and bracket assembly and place to one side to be cleaned as a special item. A liquid cleaner other than mineral

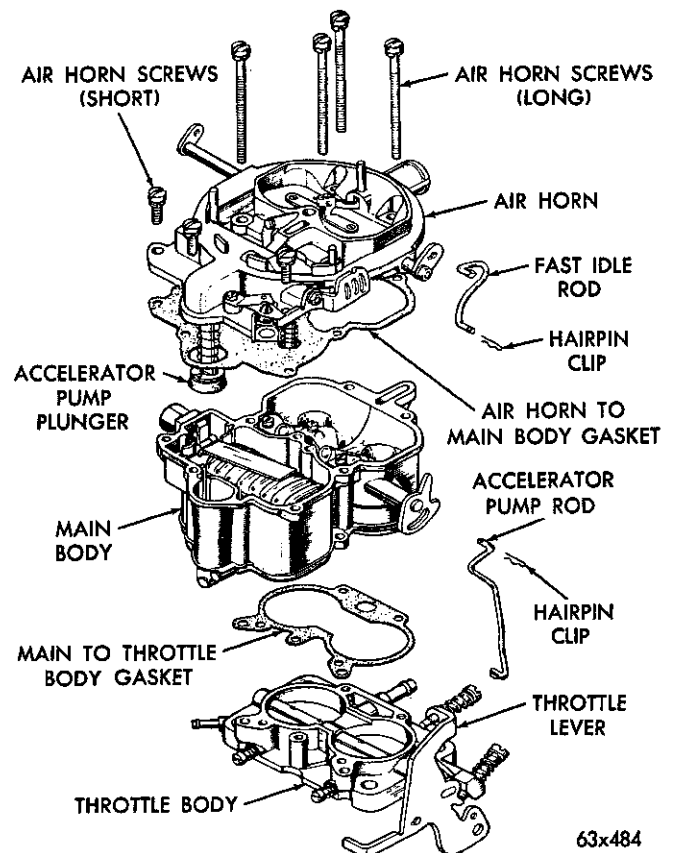

Fig. 2—Carburetor Assembly (Disassembled View)

63x484

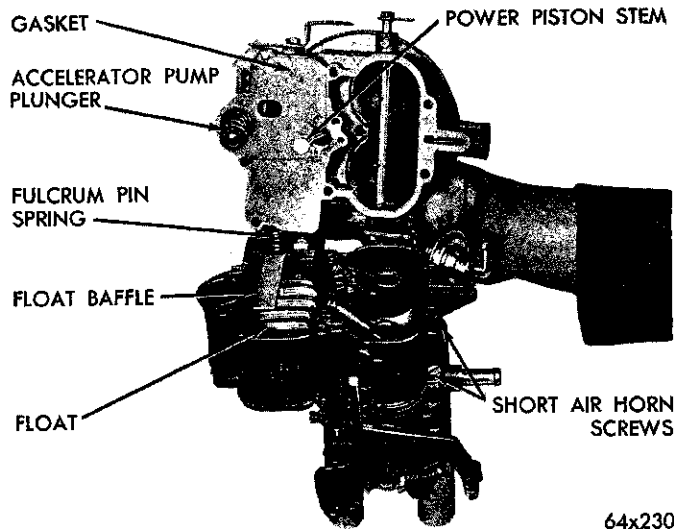

Fig. 3—Removing the Air Horn

spirits, may damage the diaphragm material.

(8) Remove the remaining air horn attaching screws, then lift air horn straight up and away from main body, as shown in Figure 3.

(9) Disengage the accelerator pump-plunger from the pump arm hook by tilting down and out from under hook, as shown in Figure 4. Remove the compression spring.

Place the accelerator pump plunger in a jar of clean gasoline or kerosene to prevent the leather from drying out.

(10) Remove the vacuum power piston from the air horn, using an open end wrench and wood block, as shown in Figure 5. (Exert sufficient pressure on end of wrench to force piston out of its well in air horn. This assembly is staked in the air horn and care should be used at removal.) Discard air horn gasket.

(11) Test the freeness of the choke mechanism in

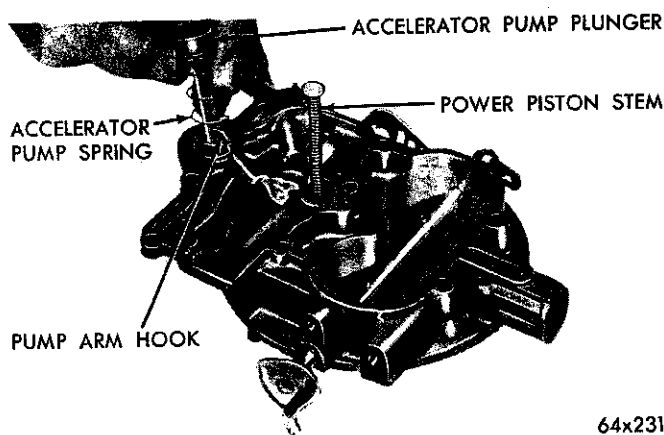

Fig. 4—Removing the Accelerator Pump Plunger

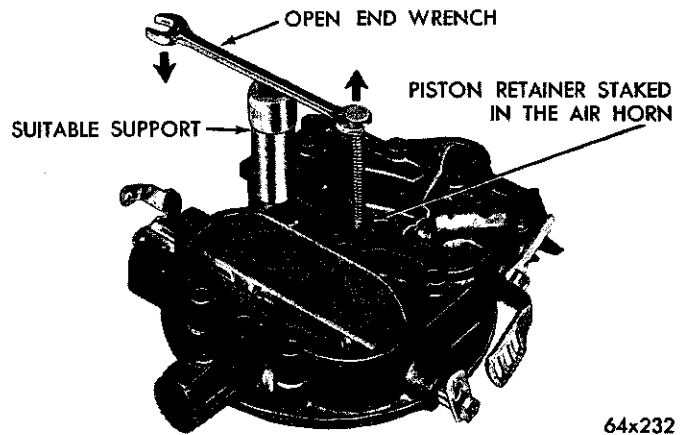

Fig. 5—Removing the Vacuum Power Piston

the air horn. The choke shaft must float free to operate correctly. If the choke shaft sticks in the bearings, or appears to be gummed from deposits in the air horn, a thorough cleaning will be required.

## 2. MAIN BODY REMOVAL

(1) Remove the venturi cluster attaching screws, the venturi cluster and gasket, as shown in Figure 6. Discard the gasket.

(2) Remove the float fulcrum pin spring, the fuel inlet needle valve, seat and gasket.

(3) Slide the float baffle up and out of its grooves, and remove the float and fulcrum pin.

(4) Invert the carburetor main body and drop out the discharge check ball from the discharge passage (Fig. 6), and the accelerator pump inlet check ball from the pump well.

(5) Using Tool 73598, remove the power by-pass jet and gaskets, as shown in Figure 7.

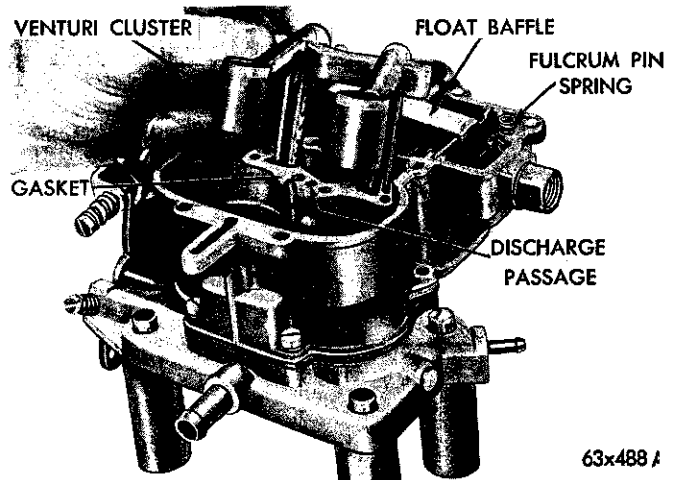

Fig. 6—Removing the Venturi Cluster

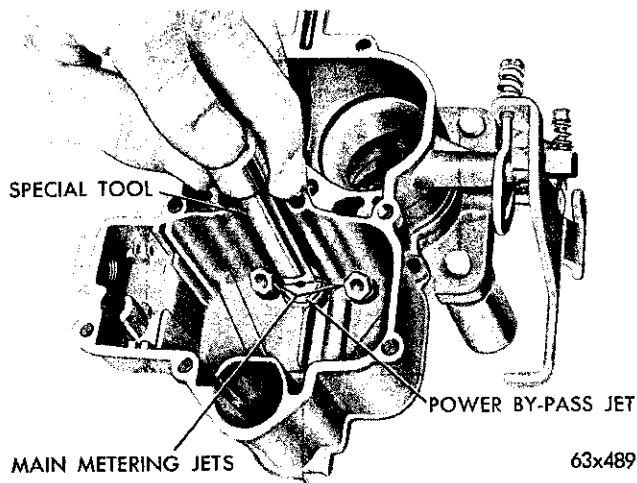

Fig. 7—Removing the Power By-Pass Jet

(6) Using Tool T109-173, remove the two main metering jets, as shown in Figure 8.

(7) Remove the two air horn screws used to hold the main and throttle bodies together. Separate the throttle and main bodies.

**3. THROTTLE BODY REMOVAL**

(1) Unscrew and remove the two idle mixture adjusting screws and springs from the throttle body.

(2) The carburetor now has been disassembled into three units; namely, the air horn, main body and throttle body and the component parts of each disassembled as far as necessary for cleaning and inspection.

**NOTE:** It is usually not advisable to remove the throttle shaft or valves unless wear or damage necessitates installation of new parts.

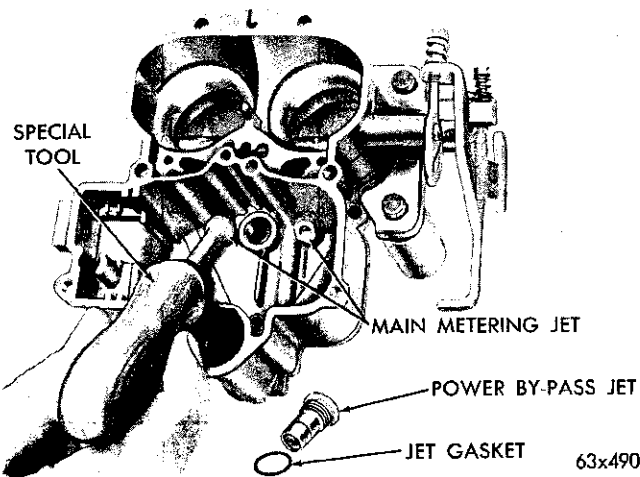

Fig. 8—Removing the Main Metering Jets

**Cleaning Carburetor Parts**

The recommended solvent for gum deposits is de-natured alcohol which is easily obtainable. There are other commercial solvents, however, such as Metalclene, which may be used with satisfactory results.

Check the throttle shaft for excessive wear in the throttle body. If wear is extreme, it is recommended that the throttle body be replaced rather than installing a new throttle shaft in the old body.

The choke diaphragm can be damaged by solvents. Avoid placing the diaphragm assembly in ANY liquid. Clean the external surfaces with a clean cloth or soft wire brush. Shake dirt or other foreign material from the stem side of the diaphragm. Depressing the diaphragm stem to the retracted position, will provide an additional hole for the removal of dirt. Compressed air can be used to remove loose dirt but should not be connected to the vacuum inlet fitting.

**IMPORTANT:** If the commercial solvent or cleaner recommends the use of water as a rinse, it should be "HOT." After rinsing, all trace of water must be blown from the passages with air pressure. It is further advisable to rinse all parts in clean gasoline or kerosene to be certain no trace of moisture remains. Never clean jets with a wire, drill or other mechanical means because the orifices may become enlarged, making the fuel mixture too rich for proper performance.

**4 INSPECTION AND REASSEMBLY**

(1) During manufacture, the location of the idle transfer ports and the spark advance control ports to the valves are carefully established for one particular assembly (Fig. 9).

(2) If a new shaft should be installed in an old worn throttle body, it would be very unlikely that the original relationship of these ports to the valves would be obtained. Changing the port relationship

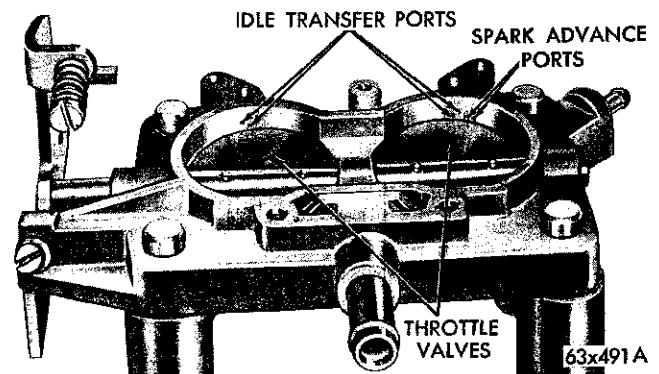

Fig. 9—Ports in Relation to the Throttle Valves

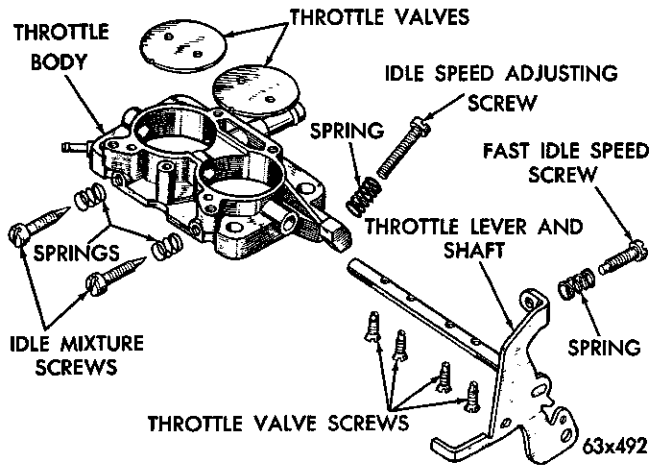

Fig. 10—Throttle Body (Disassembled View)

would adversely affect normal car operation between the speeds of 15 and 30 miles per hour. If it has been determined, however, that a new shaft or valves are to be installed, adhere closely to the following instructions:

(3) Mark the valves to be sure each is replaced in the same bore from where removed (if replacing throttle shaft only. Fig. 10.)

(4) Remove the screws that hold the throttle valves to the shaft. Slide the valves out of shaft and bore.

**CAUTION:** These screws are staked on the opposite side and care should be used at removal so as not to break the screws in the shaft. Remove the staking with a file.

(5) Slide the throttle shaft and lever out of the throttle body.

(6) Install the new throttle shaft and lever in the throttle body.

**NOTE:** The idle speed adjusting screw must be backed off when seating the valves in the following operation.

(7) Slide the valves down into position with the notches in the valves at the ports. Install new screws but do not tighten. Hold the valves in place with the fingers pressing on the high side of valves.

(8) Tap the valves lightly with a screwdriver to seat in the throttle bores. Holding the valves in this position, tighten the screws securely and stake by squeezing with pliers.

(9) Install the two idle mixture adjusting screws and spring in the throttle body. (The tapered portion must be straight and smooth.) If the tapered portion is grooved or ridged, a new idle mixture adjusting screw should be installed to insure having correct idle mixture control.

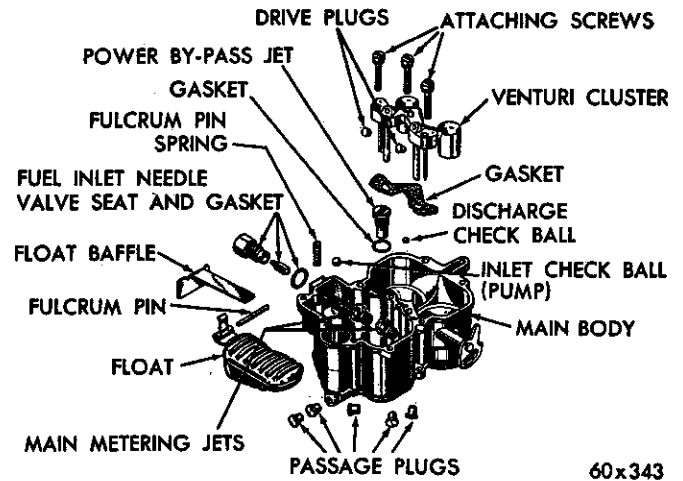

Fig. 11—Main Body (Disassembled View)

**DO NOT USE A SCREWDRIVER.** The idle mixture screw adjustment should be made with the fingers. Turn the screws lightly against their seats, then back off one full turn for an approximate setting.

### 5. MAIN BODY ASSEMBLY (Fig. 11)

(1) Place a new gasket on the throttle body, then install main body. Install two short screws to secure.

(2) Install the main metering jets in the main body. Tighten securely, using Tool T109-173 (Fig. 8).

(3) Install the power by-pass jet and new gasket. Tighten securely, using Tool 73598 (Fig. 7).

(4) Install the accelerator pump inlet check ball ( $\frac{3}{16}$  inch) in the pump well, as shown in Figure 12.

(5) Install the accelerator pump discharge check ball ( $\frac{1}{8}$  inch) in the discharge passage, as shown in Figure 13.

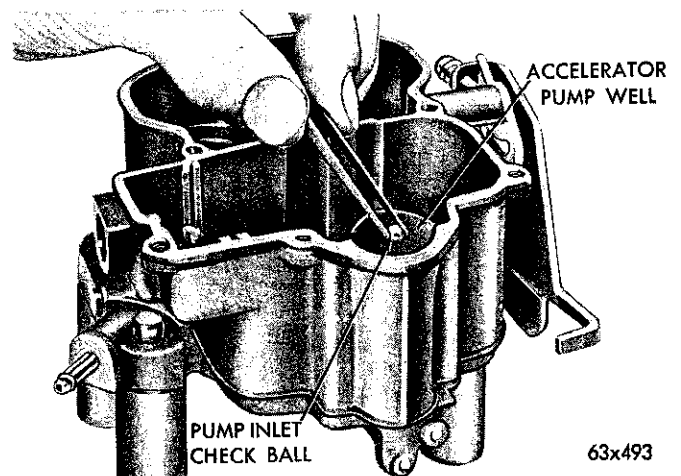

Fig. 12—Installing Accelerator Pump Inlet Check Ball



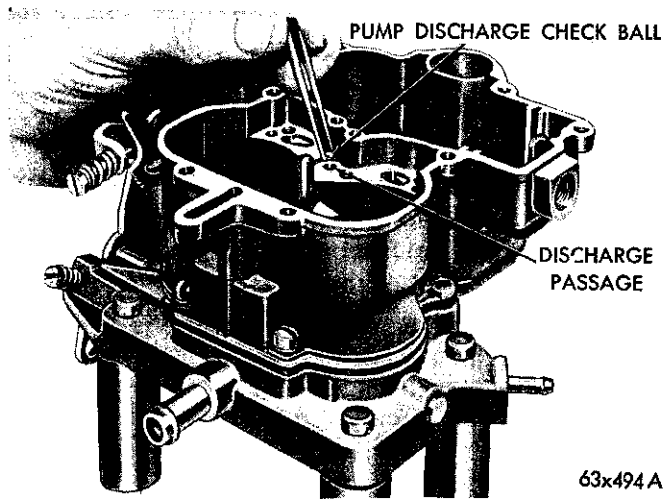

Fig. 13—Installing the Discharge Check Ball

**6. ACCELERATOR PUMP TEST**

(1) Pour clean gasoline into the carburetor bowl approximately 1/2 inch deep. Remove the accelerator pump plunger from the jar of gasoline and slide down in its well. Raise the plunger and press lightly on the plunger shaft to expel the air from the pump passage.

(2) Using a small clean brass rod, hold the discharge check ball firmly down on its seat. Raise the pump plunger and press downward. No fuel should be emitted from either intake or discharge passage, as shown in Figure 14.

(3) If any fuel does emit from either the intake or discharge passages, it indicates the presence of dirt or an imperfect seat. The passages should be recleaned and then thoroughly blown out with compressed air. Examine the ball seat for signs of dam-

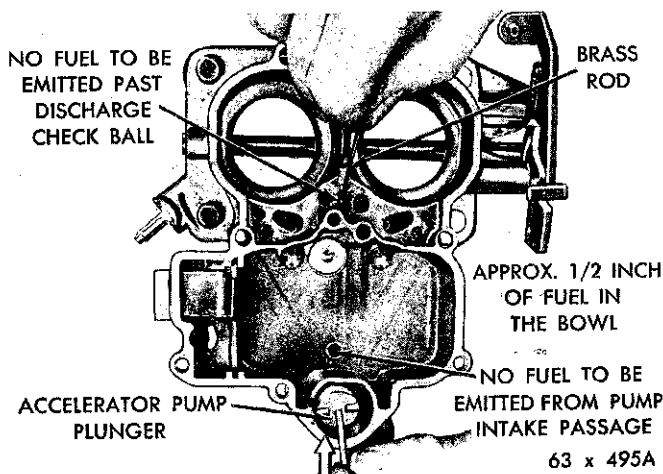

Fig. 14—Testing Accelerator Pump Discharge and Inlet Check Balls

age that would not allow the ball to seat properly.

(4) Reinstall the check ball and test again. If still leaking, place a piece of drill rod down on the check ball and rap sharply with a hammer. Remove the old check ball and install a new one. Then retest. (This operation forms a new ball seat in the carburetor casting.)

(5) Install the venturi cluster gasket and slide the venturi cluster down into position (Fig. 6). Install attaching screws and tighten securely.

Again depress the accelerator plunger. A clear straight stream should emit from each jet orifice. If streams are not identical (if either one is restricted or diverted), remove venturi cluster and reclean.

After test, pour gasoline from the bowl and remove the pump plunger.

(6) Check the float for leaks or damage. If satisfactory for further service, install in position in the bowl.

(7) Assemble the fuel inlet needle valve, seat and gasket, then insert in the main body. Tighten securely. (If the needle valve is ridged or grooved, or badly worn, a new synthetic rubber-tipped fuel inlet needle valve assembly should be installed.)

**Setting the Float Height**

The carburetor is equipped with a synthetic rubber-tipped fuel inlet needle.

(1) Invert the main body so that the weight of the floats only is forcing the needle against the seat. **Be sure hinge pin does not drop out of the float hinge.** Hold down with the fulcrum pin spring.

(2) Using Tool 73725 or a "T" scale, measure the float level, as shown in Figure 15. There should be 5/32 inch from the surface of the fuel bowl to the crown of the float at the center.

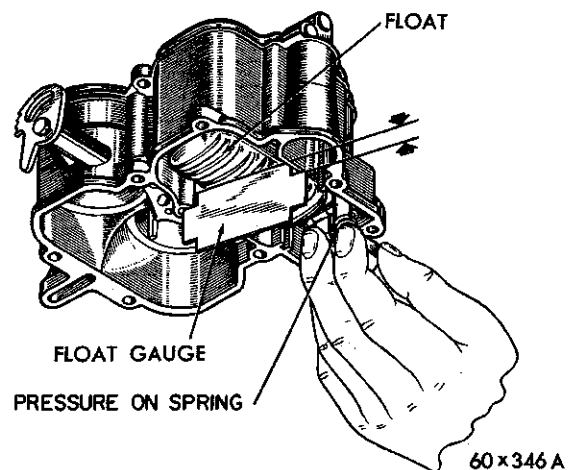

Fig. 15—Measuring the Float Setting

If an adjustment is necessary, remove the needle valve and seat, the fulcrum pin retainer spring, the floats and fulcrum pin. Bend the lip of the float lever either in or out until correct setting has been obtained.

**CAUTION:** Do not attempt to change the setting without removing the float, as the synthetic rubber tip can be compressed sufficiently to cause a false setting, which will affect correct level of fuel in the bowl.

**NOTE:** It is important that the float lip is perpendicular to the needle or slanted not more than 10 degrees away from the needle when the float is set correctly. Do not bend the float lip by forcing the float, use Tool 73605.

(3) Install float, needle and seat and tighten seat securely. Slide the float baffle down into position and install the fulcrum pin spring. Remeasure as described in Step 2 above.

### Air Horn Assembly (Fig. 16)

(1) Slide the choke shaft and lever into the air horn with the choke lever pointing down and away from the air horn. Slide the choke valve down into the slot in the shaft.

(2) Hold the choke valve closed and install new screws. DO NOT TIGHTEN. While holding the valve in the closed position, tap gently with a screwdriver, to center and locate the valve.

(3) Tighten attaching screws securely, then stake by squeezing with pliers. Reinstall the fast idle lever and secure with lockwasher and nut.

(4) Soak the accelerator pump plunger in a jar of clean gasoline. Test the leather. If the leather is hard, cracked, or worn, install a new pump plunger. Be

sure and flex the leather several times before installing plunger in air horn.)

(5) Slide the compression spring over plunger shaft, then slide plunger over hook and into position (Fig. 4).

(6) Install a new air horn gasket, then install the vacuum power piston in air horn. Lock the piston in position by prick punching on the retaining rim. Compress the piston plunger to be sure no binding exists. If the piston sticks or binds enough to hinder smooth operation, install a new piston assembly.

(7) Install the air horn assembly on the main body, guiding the pump plunger into its well (Fig. 2). (Be sure the leather does not curl or fold back.) Install retaining screws and tighten securely.

**NOTE:** The choke valve must be held partially closed while installing the air horn.

(8) Remove the two short screws holding the main body and throttle body together (Fig. 2), and install in air horn. Reinstall the two long screws and tighten securely.

(9) Install the fast idle rod and secure with the hairpin clip.

(10) Install the pump rod and secure with hairpin clip. (Be sure rod is in the center slot of arm, refer to Figure 1.) Work the accelerator pump plunger several times to be sure it operates smoothly.

### Installing the Vacuum Diaphragm

(1) Install the diaphragm assembly on the air horn and tighten the attaching screws securely.

(2) Install the choke operating link in position between the diaphragm stem (plunger) and the choke lever. Install the clip to secure.

(3) Inspect the vacuum diaphragm fitting and remove any dirt or foreign material which could plug the passage. Inspect the rubber vacuum hose for cracks before placing it on the correct vacuum fitting. (Refer to Fig. 1.)

Do not connect the vacuum hose to the diaphragm fitting until after the vacuum kick adjustment has been made. (See Carburetor Adjustments.)

## 7. CARBURETOR ADJUSTMENTS

It is very important that the following adjustments be made on a reconditioned carburetor and in the sequence listed:

- Fast Idle Speed and Cam Position Setting.
- Vacuum Kick Adjustment.
- Unloader Adjustment (Wide Open Kick).

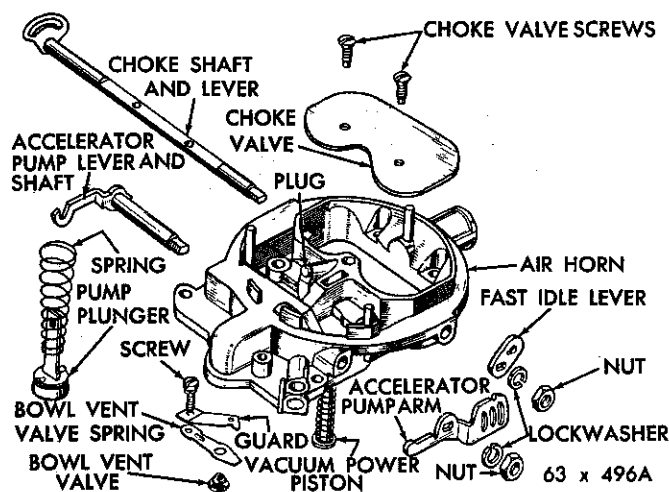

Fig. 16—Air Horn (Disassembled View)

- (d) Accelerator Pump Travel.
- (e) Bowl Vent Valve Setting.

**Fast Idle Speed and Cam Position Adjustment**

The fast idle engine speed adjustment should be made on the vehicle, as described in the "Fast Idle Speed Adjustment" (On the vehicle) paragraph of this group, however, the Fast Idle Cam Position Adjustment can be made on the bench, as follows:

- (1) With the fast idle speed adjusting screw contacting the lowest step on the fast idle cam, as shown in Figure 17, move the choke valve toward the closed position with light pressure. Insert a 1/4 inch drill or gauge (Auto. Trans.) 1 1/4 inch (Manual Trans.) between the choke valve and the wall of the air horn.
- (2) An adjustment will be necessary if a slight drag is not obtained as the drill or gauge is being removed.
- (3) If an adjustment is necessary, bend the fast idle rod at the upper angle, using Tool T109-213, until the correct valve opening has been obtained.

**Vacuum Kick Adjustment**—(This test can be made ON or OFF the vehicle.

To make the vacuum kick adjustment, the vacuum diaphragm must be energized (either a distributor testing machine with a vacuum source, or vacuum supplied by another vehicle.) To make this adjustment, proceed as follows:

- (1) With the engine **Not** running, open the throttle valves far enough to allow the choke valve to be moved to the closed position.
- (2) Disconnect the vacuum hose from the diaphragm and connect the hose from the vacuum supply, as shown in Figure 18. (A minimum of 10

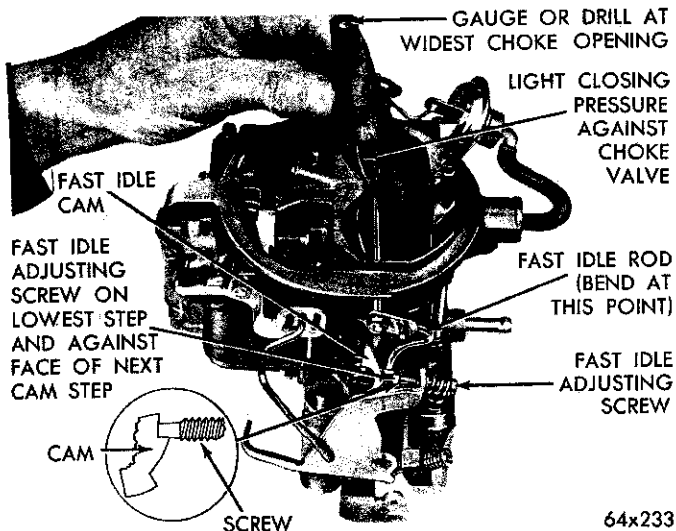

**Fig. 17—Fast Idle Speed and Cam Position Adjustment**

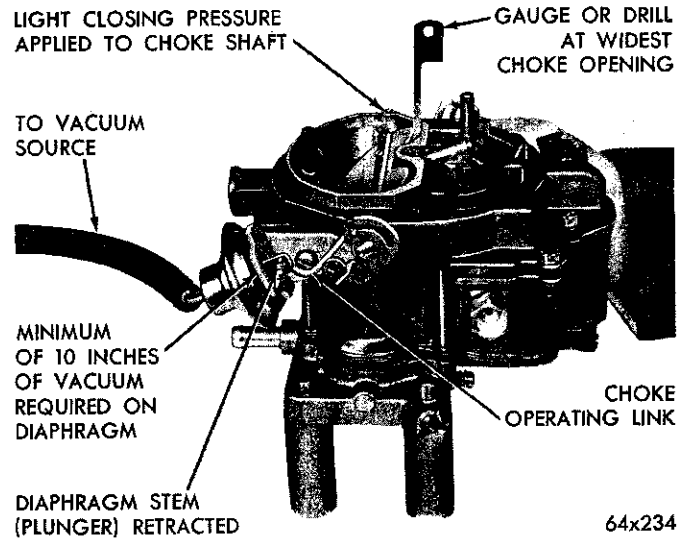

**Fig. 18—Measuring the Choke Vacuum Kick Setting**

inches of mercury (HG) will be required).

(3) Insert a 3/32 inch drill or gauge (Manual Transmission) or an 1 1/4 inch (Automatic Transmission) between the choke valve and the wall of the air horn. (Refer to Fig. 18.) Apply a slight closing pressure to the choke shaft to hold the drill or gauge in position.

(4) An adjustment will be necessary if a slight drag is not obtained as the drill or gauge is being removed.

The adjustment of this opening will require the removal of the choke operating link.

**CAUTION: DAMAGE TO THE DIAPHRAGM AND THE CHOKE LEVER SLOT CAN RESULT, IF THE LINK IS NOT REMOVED FOR THE BENDING OPERATION.**

(5) Remove the clip and disengage the choke operating link from the choke lever, then disengage the link from the diaphragm stem. (The best bending results will be obtained by using a vise and a pair of pliers.)

(6) Bend the choke operating link at the angle to provide the correct choke valve opening.

**CAUTION: A correction in the length of the link of .010 inch, will result in a change of .010 inch in the choke valve opening.**

As an example, if the choke valve opening is .010 inch in error, the correction in the link length would be .010 inch.

A 2" micrometer will be helpful in establishing the original length of the link, as shown in Figure 19, before completing the adjustment.

(7) Install the choke operating link and remeasure the choke valve opening, using a gauge or drill. (Refer to Fig. 18.)

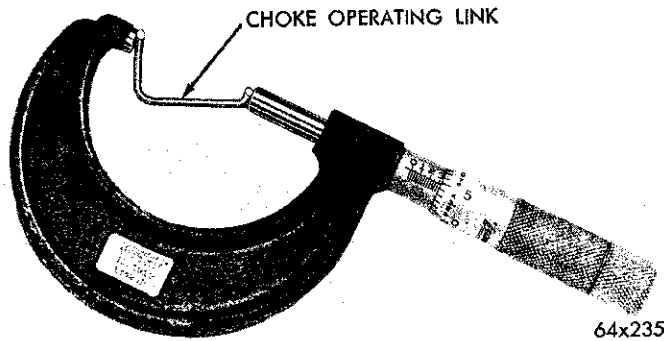

Fig. 19—Choke Operating Link Measurements

Reinstall the vacuum hose to the diaphragm and make the following test:

(8) With no vacuum applied to the diaphragm, some clearance should exist between the choke operating link and the choke lever slot, in both the open and closed choke valve positions, as shown in Figure 20. This clearance is necessary to allow the choke valve to close for starting as well as fully open after the engine reaches the normal operating temperature.

If a clearance does not exist in both of these positions, a retest of the operating link adjustment should be made.

**FREE** movement of the choke valve between the closed and open positions is very necessary.

This free movement should also exist between the kick and the open choke valve positions with the engine running. If binding does exist, the choke opera-

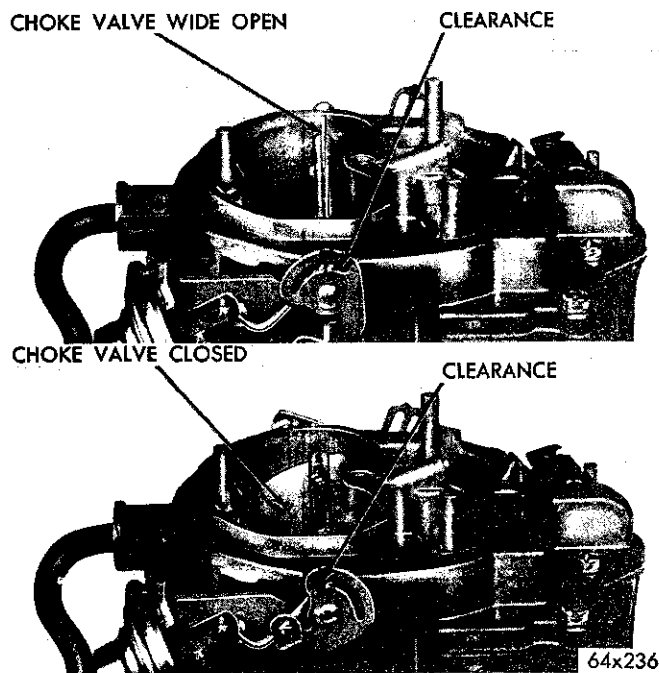

Fig. 20—Choke Operating Link Clearances

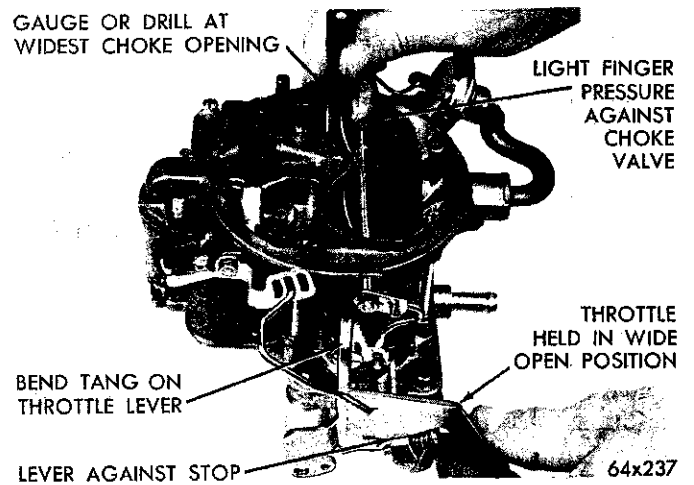

Fig. 21—Unloader Adjustment (Wide Open Kick)

ting link has been improperly bent and should be corrected.

**Unloader Adjustment (Wide Open Kick) (Fig. 21)**

(1) Lightly hold the choke valve closed, then open the throttle valves to the wide open position. The choke valve should be open sufficiently to allow a  $1\frac{5}{64}$  inch drill to be inserted between the choke valve and the wall of the air horn as shown.

(2) To adjust, bend the tang on the throttle lever, using Tool T109-214, until correct opening has been obtained.

(3) Hold the choke valve open and then open and close the throttle valves. Failure to obtain full throttle operation indicates improper assembly.

(4) With the throttle valves held in an open posi-

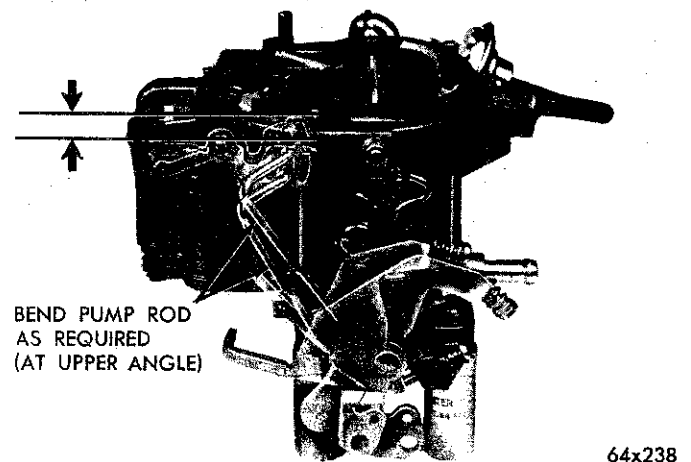

Fig. 22—Accelerator Pump Travel

tion, the choke valve should fall open freely. There should be no bind throughout the entire travel of the choke mechanism.

**Accelerator Pump Travel (Fig. 22)**

(1) With the throttle valves fully closed, measure the pump travel from the fully closed to the fully open throttle.

(2) This travel should be  $\frac{7}{16}$  inch as shown.

(3) If an adjustment is necessary, bend the pump rod at the point shown, using Tool T109-213, until correct travel has been obtained.

**Bowl Vent Valve Setting (Fig. 23)**

This setting is made after the pump travel setting.

(1) With the throttle valves at curb idle, there should be  $\frac{1}{16}$  inch clearance between the bowl vent valve and the air horn, when measured (at the center of the vent valve and the seat) with a gauge or drill shank.

(2) If an adjustment is necessary, bend the bowl vent lever, using Tool T109-214, until the correct opening has been obtained.

**Idle Speed Adjustment**

For the best results, it is recommended that a tachometer be used in this adjustment.

(1) Turn the idle speed screw in or out to obtain 500 rpm. (On vehicles with air conditioning, set the idle speed at 500 rpm, with air conditioning ON). Be sure the choke valve is fully open and that the fast idle adjusting screw is not contacting the fast idle cam (engine off fast idle).

(2) Turn each idle mixture screw in or out until smooth idle is obtained.

(3) Readjust to 500 rpm with the idle speed screw.

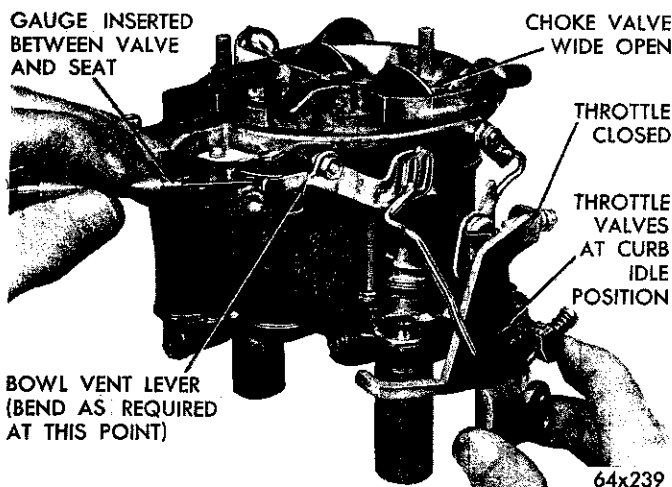

Fig. 23—Measuring Bowl Vent Valve Opening

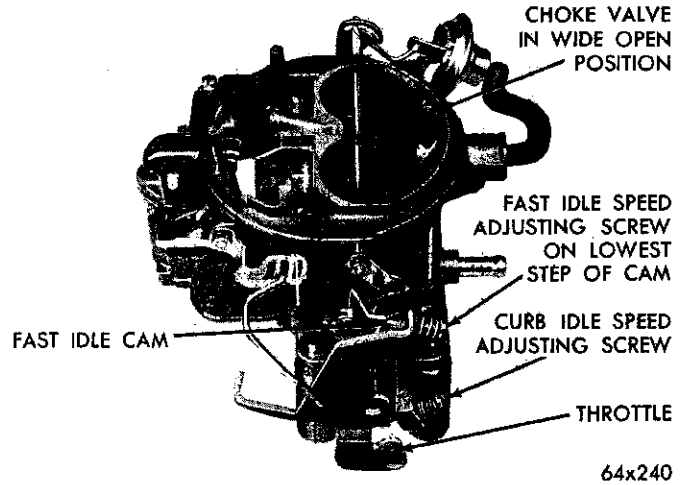

Fig. 24—Fast Idle Speed Adjustment (On the Car)

(4) Repeat the idle mixture screw adjustment.

**Fast Idle Speed Adjustment (On the Engine)**

To set the fast idle speed on the engine connect a tachometer to the vehicle, then set the curb idle speed and proceed as follows:

(1) With the engine running and the transmission in the neutral position, open the throttle slightly.

(2) Close the choke valve about 20 degrees then allow the throttle to close. Return the choke valve to the open position.

(3) The fast idle speed adjusting screw should be contacting the lowest step on the fast idle cam, as shown in Figure 24.

(4) With the engine warmed-up to the normal operating temperature, turn the fast idle speed adjusting screw in or out to secure 700 r.p.m. (Automatic Transmission) or 600 r.p.m. (Manual Transmission). Reposition the cam and throttle after each adjustment.

**Measuring the Float Setting or Fuel Level (On the Vehicle)**

Remove the three short air horn to main body attaching screws. Then remove one long air horn to throttle body screw next to fuel bowl and assemble short screw through main body flange and thread into the throttle body. Remove long screw from side away from fuel bowl and on opposite side and assemble short screw through main body flange. Securely tighten. Remove the air horn as follows:

(1) Remove the spring clip and disconnect the choke operating rod.

(2) Remove the hairpin clip and disconnect the fast idle rod.

(3) Remove the hairpin clip that holds the pump rod in the center slot of the pump arm. Disconnect the pump rod.

(4) Remove the remaining two long screws and lift off the air horn.

Check the float setting as follows:

(1) Seat the float fulcrum pin by pressing finger against the fulcrum pin spring.

There should be enough fuel in the bowl to raise the float so that the lip bears firmly against the needle. Additional fuel may be admitted by slightly depressing the float. If the fuel pressure in the line is insufficient to force additional fuel into the bowl, add the necessary fuel from a clean container.

**CAUTION:** Since the manifolds may be hot, it is dangerous to spill fuel onto these surfaces. Therefore, take the necessary precautions to avoid spillage.

(2) With only the pressure from the buoyant float holding the lip against the inlet needle, check the float setting, using Tool 73725 or "T" scale. There should be  $\frac{5}{32}$  inch from the surface of the bowl (gasket removed) to the top of the float at the center.

If an adjustment is necessary, hold the float on the bottom of the bowl, then bend the float lip toward or away from the needle, using Tool 73605. Recheck the  $\frac{5}{32}$  inch setting again, then repeat the lip bending operation as required.

**CAUTION:** When bending the float lip, do not allow the lip to push against the needle as the rubber tip can be compressed sufficiently to cause a false setting which will affect correct level of fuel in the bowl. After being compressed, the rubber tip is very slow to recover its original shape.

It is very important that the float lip be perpendicular to the needle or slanted not more than 10 degrees away from the needle when the float is set correctly.

(3) Reassemble the air horn.

## 8. AUTOMATIC CHOKE (Well Type)

To function properly, it is important that all parts be clean and move freely. Other than an occasional cleaning, the automatic choke control requires no servicing. It is very important, however, that the choke control unit works freely at the thermostatic coil spring housing and at the choke shaft.

Move the choke rod up and down to test for free movement of the coil housing on the pivot. If the unit binds, a new unit should be installed.

**NOTE:** The well type choke unit is serviced only as a complete unit. Do not attempt to repair.

When installing the well type choke unit, make certain that the coil housing does not contact the sides of the well. Any contact at this point will affect choke operation.

Do not lubricate any of the choke parts or the control unit, since this causes dirt to accumulate which would result in a binding condition of the choke mechanism.

Do not attempt to change the calibration setting. This is pre-determined and should it be changed, improper choke action would result.

The choke control unit is accurately adjusted when originally assembled. Under normal service operation, it is recommended not to change the setting, or to disassemble the components for servicing. If, however, the setting has been disturbed, reset as follows:

Loosen locknut and turn part with screwdriver until index mark on disc coincides with the first mark to the right of center mark on the bracket. Hold in this position with screwdriver while tightening nut.

**NOTE:** After adjustment is made and the choke unit installed on the engine, lift the cover disc and check to see that the rod has clearance when the choke is opened and closed. The rod should have clearance at hole in cover plate.

Should it become necessary to adjust the throttle linkage, refer to Figure 18 for the complete instructions.

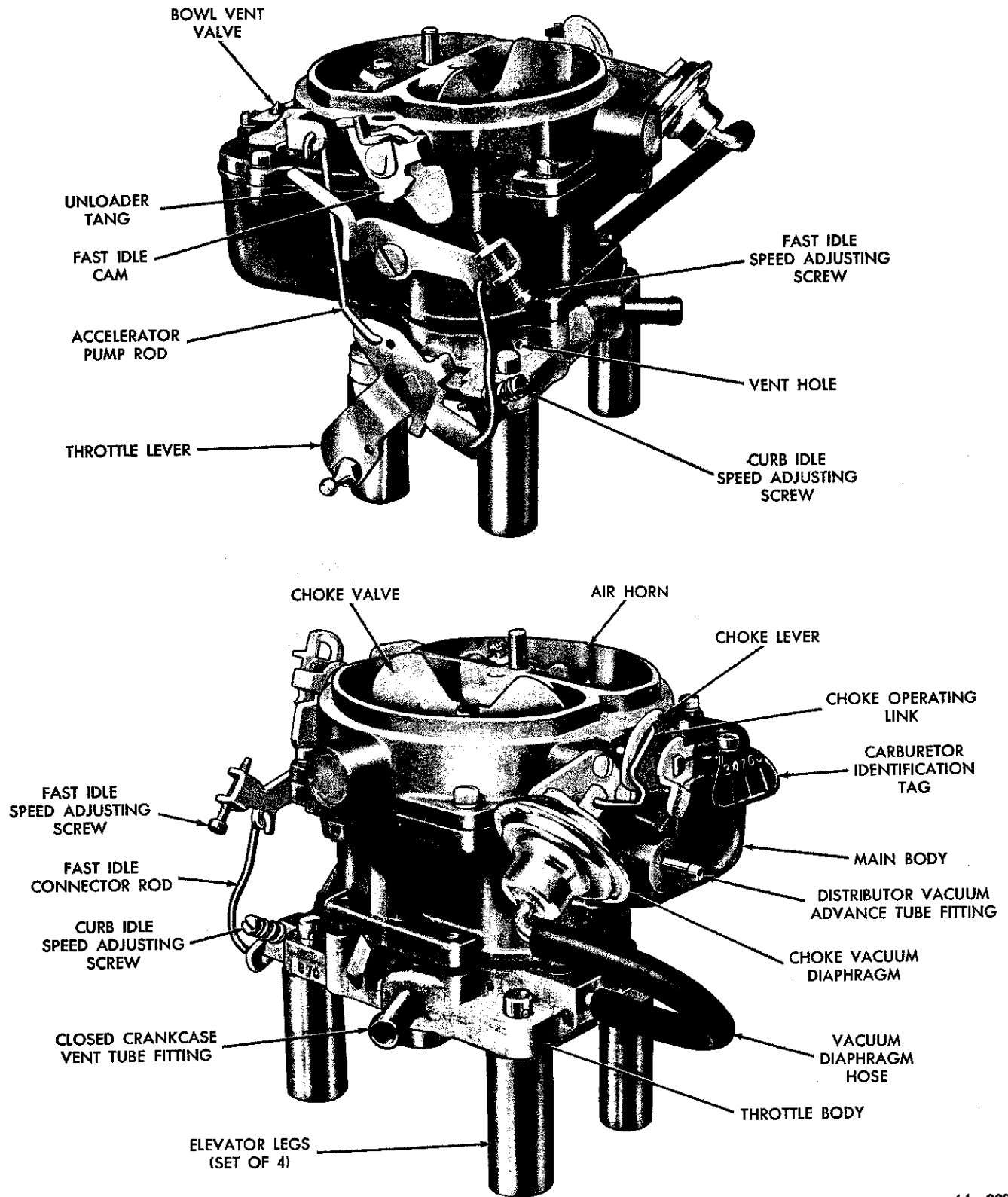

Fig. 1—Carburetor Assembly (BBD-3685S)

## PART 2

## MODEL BBD 3685S CARBURETORS

Dirt, dust, water and gummy deposits are some of the main causes for poor carburetor operation. Proper cleaning, however, and installation of new parts, where required, will return the carburetor to its originally designed performance.

When overhauling the carburetor, several items of importance should be observed to assure a good

job. All parts (except the diaphragm assembly) should be carefully cleaned in a suitable solvent and inspected for damage and wear. Replace questionable parts with new ones.

Use air pressure only, to clear the various orifices and passages.

## SERVICE PROCEDURES

## 1 CARBURETOR DISASSEMBLY (Fig. 1)

(1) Insert three Tool T109-287S and one Tool T109-288S elevating legs through the carburetor throttle body stud holes. (These tools are used to protect the throttle valves from damage and to provide a suitable base for working.)

(2) Remove the hairpin clip and disengage the fast idle connector rod from the throttle and fast idle levers.

(3) Remove the hairpin clip and disengage the accelerator pump rod from the throttle lever and the pump rocker arm.

(4) Remove the vacuum hose between the carburetor throttle body fitting and the vacuum diaphragm.

(5) Remove the clip from the choke operating link and disengage the link from the diaphragm plunger and the choke lever. (Refer to Fig. 1.)

(6) Remove the vacuum diaphragm and bracket assembly and place to one side, to be cleaned as a special item. **A liquid cleaner other than mineral spirits, may damage the diaphragm material.**

(7) Remove the air horn retaining screws and lift air horn straight up and away from the main body. Discard the gasket.

(8) Disengage the accelerator pump plunger from the accelerator pump arm by pushing up on the bottom of the plunger and sliding the plunger shaft off the hook. Slide the plunger out of the air horn and remove the compression spring and seat.

If the old plunger can be used again or if a new plunger is to be installed, place the plunger in a jar of clean gasoline or kerosene to prevent the leather from drying out.

(9) Remove the fuel inlet needle valve, seat and gasket from the main body.

(10) Lift out the float fulcrum pin retainer, and lift out the floats and fulcrum pin.

(11) Remove the step-up piston and retaining screw and slide the step-up piston and rods out of well, as shown in Figure 2. Lift out the step-up piston

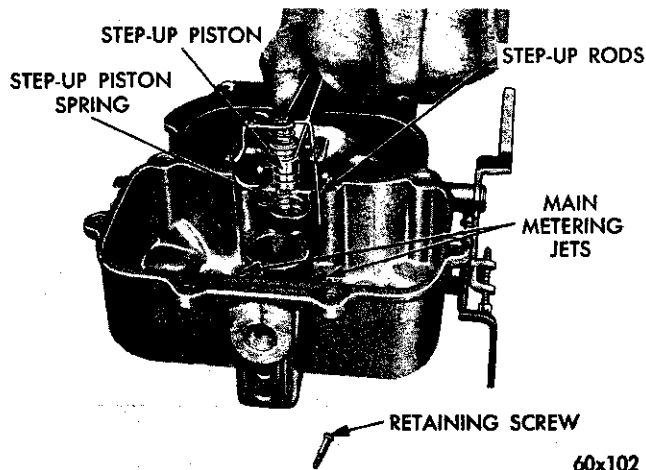

Fig. 2—Removing the Step-up Piston

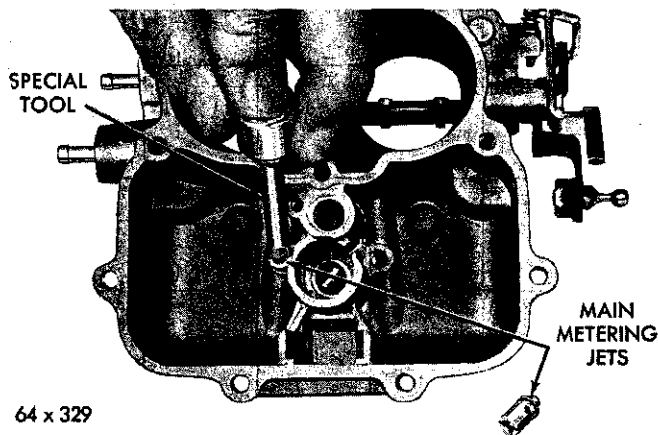

Fig. 3—Removing the Main Metering Jet



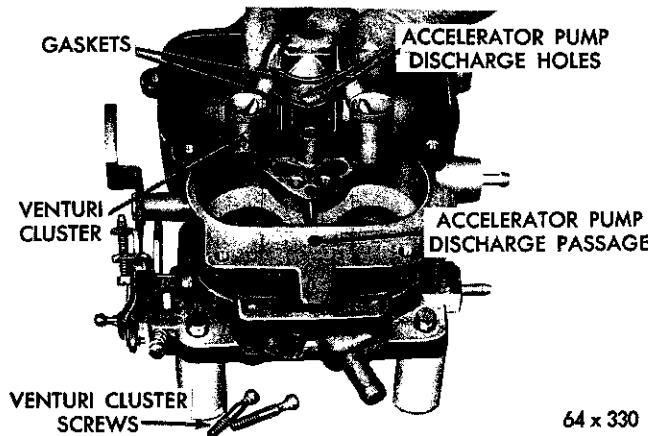

Fig. 4—Removing the Venturi Cluster

spring. Remove the step-up piston gasket from the bottom of the well.

(12) Remove the main metering jets and gaskets, as shown in Figure 3.

(13) Remove the venturi cluster screws, then lift the venturi cluster and gaskets up and away from the main body, as shown in Figure 4. Discard the gaskets. **Do not remove the idle orifice tubes or the main vent tubes from the cluster.** They can be cleaned in a solvent and dried with compressed air.

(14) Invert the carburetor and drop out the accelerator pump discharge check ball.

(15) Remove the idle mixture adjusting screws and springs from the throttle body.

(16) Remove the screws that attach the throttle body to the main body. Separate the bodies and discard the gasket.

The carburetor now has been disassembled into three sub-assemblies, the air horn, main body and throttle body and the components of each disassembled as far as necessary for cleaning and inspection.

It is usually not advisable to remove the throttle shaft or valves from the throttle body, unless wear or damage necessitates the installation of new parts.

## 2. CLEANING CARBURETOR

The recommended solvent for gum deposits is denatured alcohol which is easily obtainable. There are other commercial solvents, however, which may be used with satisfactory results.

The choke diaphragm can be damaged by solvents. Avoid placing the diaphragm assembly in **ANY** liquid. Clean the external surfaces with a clean cloth or soft wire brush. Shake dirt or other foreign material from the stem side of the diaphragm. Depressing the diaphragm plunger (stem) to the retracted position, will

provide an additional hole for the removal of dirt. Compressed air can be used to remove loose dirt but should not be connected to the vacuum inlet fitting.

**IMPORTANT:** If the commercial solvent or cleaner recommends the use of water as a rinse, it should be "HOT." After rinsing, all trace of water must be blown from the passages with air pressure. It is further advisable to rinse all parts in clean kerosene or gasoline to be certain no trace of moisture remains. Never clean jets with a wire, drill or other mechanical means, because the orifices may become enlarged, making the mixture too rich for proper performance.

## 3. INSPECTION AND REASSEMBLY

### Throttle Body

(1) Inspect the throttle shaft and throttle body for excessive wear. If either or both are worn to the point where the carburetor operation will be affected, replace as required.

During manufacture, the location of the idle transfer port and the spark advance control ports to the throttle valve, is carefully established for one particular assembly (Fig. 5).

If a new shaft should be installed in an old, worn throttle body, it would be very unlikely that the original relationship of the ports to the valves would be obtained. Changing the relationship of the valves to the ports would adversely affect normal car operation between the speeds of 15 and 30 miles per hour. If it has been determined, however, that a new shaft or valves is to be installed, adhere to the following instructions.

(2) Mark the position of the throttle valves in the bores. Be sure the idle speed screw is backed off.

(3) Remove the screws that hold the throttle valves to the shaft and slide the valves out of the bores.

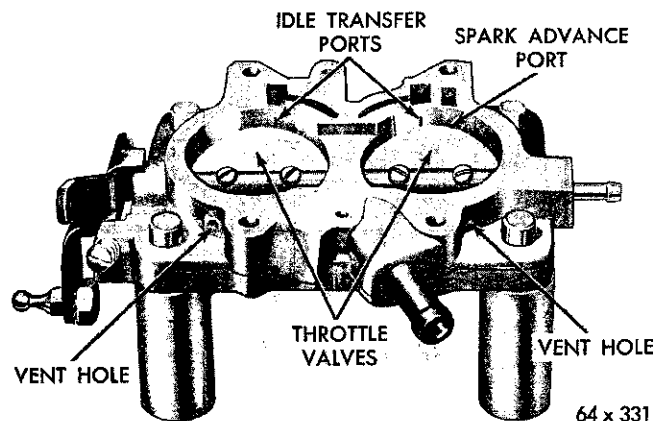

Fig. 5—Ports in Relation to Throttle Valves

**CAUTION:** These screws are staked on the opposite side and care should be used at removal so as not to break off in the shaft. Remove the staked end of the screws with a file.

(4) Slide the throttle shaft and lever out of the body.

(5) Install new throttle shaft and lever.

(6) Install throttle valves in their respective bores (with the valve number toward the manifold). Install new screws but do not tighten. Hold the valves in place, with the fingers pressing on the high sides of the valves. Tap the valves lightly with a screwdriver to seat in the throttle bores. Tighten the screws securely and stake by squeezing with pliers.

(7) Install the idle mixture screws and springs in the throttle body. (The tapered portion must be straight and smooth. If the tapered portion is grooved or ridged, new idle mixture screws should be installed to insure having correct idle mixture control.) **DO NOT USE A SCREWDRIVER.** Turn the screws **lightly** against their seats with the fingers. Back off one full turn for approximate adjustment.

**Main Body**

(1) Invert the main body and place a new gasket in position and place the throttle body on the main body and align. Install screws and tighten securely.

(2) Install the accelerator pump discharge check ball in the discharge passage and check the accelerator pump system; fuel inlet and discharge check balls as follows:

(3) Pour clean gasoline into the carburetor bowl, approximately 1/2 inch deep. Remove the pump plunger from the jar of gasoline, flex the leather several times, then slide down into the pump cylinder. Raise the plunger and press lightly on the plunger shaft to expel all air from the pump passage.

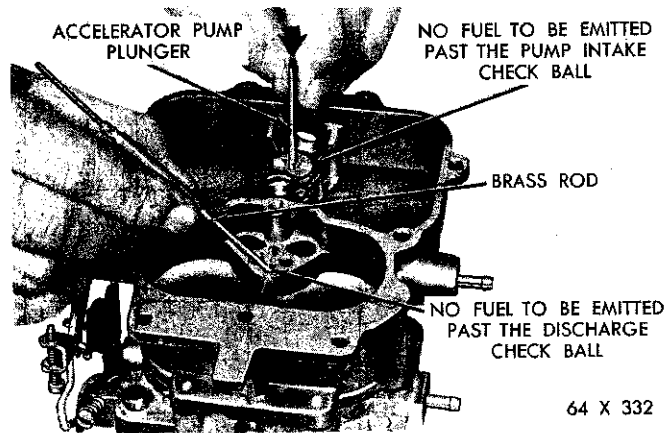

Fig. 6—Testing the Accelerator Pump Intake and Discharge Check Balls

(4) Using a small clean brass rod, hold the discharge check ball down firmly on its seat. Again raise the plunger and press downward. No fuel should be emitted from either the intake or discharge passage, as shown in Figure 6.

If any fuel does emit from either passage it indicates the presence of dirt or a damaged check ball seat. Check the passage again and repeat test. If leakage is still evident, install a new check ball.

The fuel inlet check ball is located at the bottom of the plunger well.

(5) Install new gaskets on the venturi cluster, and install in position in the main body (Fig. 4). Install the idle bleed screws and tighten securely. Test pump discharge by pressing pump plunger down. Two fine streams of fuel should be forced from the cluster. If either stream is restricted or diverted, remove cluster and reclean. After test, pour the fuel from the bowl and remove pump plunger.

(6) Install the main metering jets and gaskets. Tighten securely (Fig. 3).

(7) Before installing the step-up piston, be sure the step-up rods are able to move freely, each side of the vertical position, as shown in Figure 7. The step-up rods must be straight and smooth.

(8) Slide the step-up piston gasket down into position in the piston well, then install the step-up piston springs, step-up piston and rods. Carefully guide the step-up rods into the main metering jets (Fig. 2). Install the retaining screw and tighten securely. Check piston for free operation in the well.

A step-up piston stuck in the **Up** position will cause a rich mixture at part throttle, whereas a piston stuck in the **Down** position will cause a lean mixture at wide open throttle and poor acceleration.

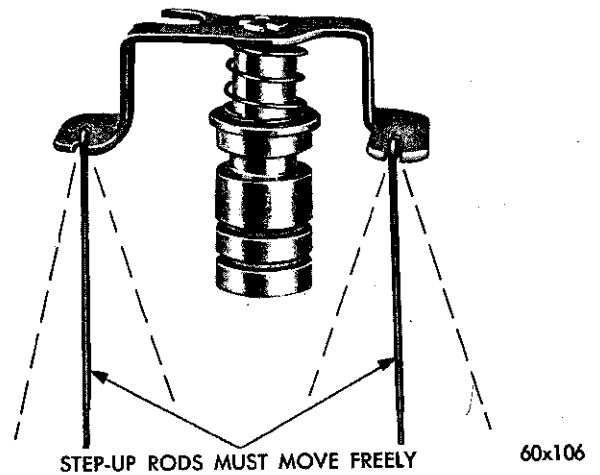

Fig. 7—Step Up Rods Free Play

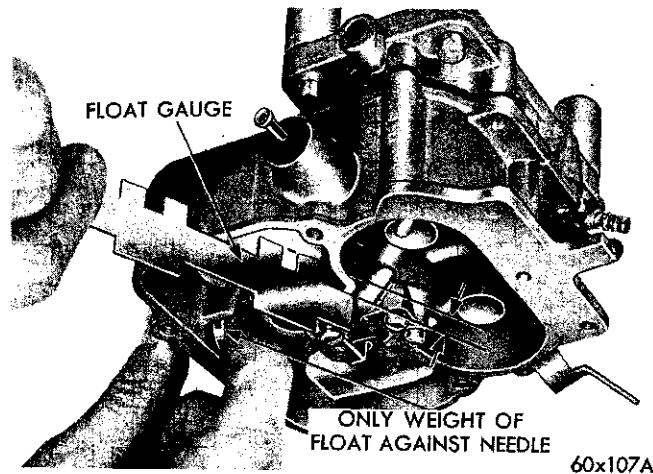

Fig. 8—Measuring the Float Setting

### Measuring the Float Setting (Off the Vehicle)

The carburetors are equipped with a rubber-tipped fuel inlet needle. The rubber tip is flexible enough to make a good seal on the needle seat, and to give increased resistance to flooding.

The use of the rubber-tipped needle requires a new procedure in adjusting the float setting. Care should be taken to perform this operation accurately in order to secure the best performance and fuel economy.

(1) To correctly set the float height when the carburetor is being overhauled, install the floats with the fulcrum pin and pin retainer in the main body.

(2) Install the rubber-tipped needle, seat and gasket in the body and tighten securely.

(3) Invert the main body so that the weight of the float only is forcing the needle against the seat. Hold finger against the retainer to fully seat the fulcrum pin.

(4) Using Tool T109-282, or a "T" scale, measure the float, as shown in Figure 8. There should be  $\frac{1}{4}$  inch from the surface of the fuel bowl to the crown of each float at the center.

If an adjustment is necessary, hold the floats on the bottom of the bowl and bend the float lip toward or away from the needle. Recheck the  $\frac{1}{4}$  inch setting again and repeat the lip bending operation as required.

**CAUTION:** When bending the float lip, do not allow the lip to push against the needle as the rubber tip can be compressed sufficiently to cause a false setting which will affect correct level of fuel in the bowl.

**NOTE:** After being compressed, the rubber tip is very slow to recover its original shape. It is very important that the float lip be perpendicular to the needle or slanted not more than 10 degrees away from the needle when the float height is correct.

### Air Horn

(1) Test the freeness of the choke mechanism in the air horn. The choke shaft must float free to operate correctly. If the choke shaft sticks in the bearings, or appears to be gummed from deposits in the air horn, a thorough cleaning will be required.

(2) Remove the accelerator pump plunger from the gasoline, slide the compression spring and spring seat over the shaft. Install the assembly in the air horn and engage with the accelerator pump arm.

(3) Place a new gasket on the main body, and install the air horn. Install attaching screws and tighten securely. (When installing air horn, be sure the leather on the plunger does not wrinkle or fold back.)

(4) Engage the accelerator pump rod with the pump rocker arm and install loose end in the center hole of throttle lever. Install hairpin clip to secure.

(5) Engage the fast idle connector rod in the fast idle lever and throttle lever. Install hairpin clip to secure.

### Installing the Vacuum Diaphragm

(1) Install the diaphragm assembly on the air horn and tighten the attaching screws securely.

(2) Install the choke operating link in position between the diaphragm plunger (stem) and the choke lever. Install the clip to secure.

(3) Inspect the vacuum diaphragm fitting and remove any dirt or foreign material which could plug the passage. Inspect the rubber hose for cracks, before placing it on the correct fitting. (Refer to Fig. 1.)

Do not connect the vacuum hose to the diaphragm fitting until after the vacuum kick adjustment has been made. (See Carburetor Adjustments.)

## 4. CARBURETOR ADJUSTMENTS

It is very important that the following adjustments are made on a reconditioned carburetor and in the sequence listed:

### Accelerator Pump

(1) Back off the idle speed adjusting screw. Open the choke valve so that the fast idle cam allows the throttle valves to be completely seated in the bores. Be sure that the pump connector rod is installed in the center hole of the throttle lever.

(2) Close the throttle valves tightly. Measure the

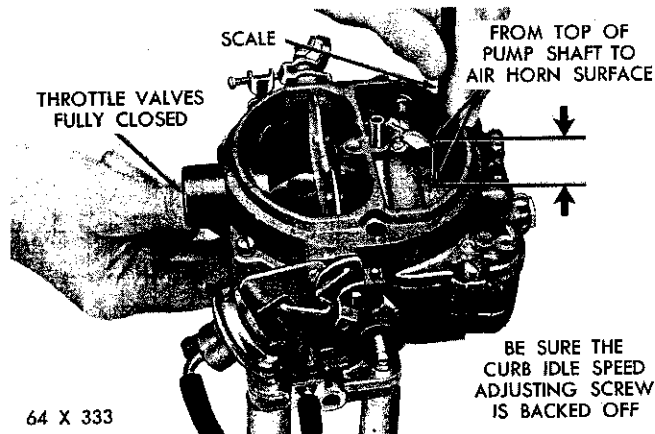

Fig. 9—Measuring the Accelerator Pump Travel

distance between the top of the air horn and the end of plunger shaft, as shown in Figure 9. This measurement should be  $1'' +$  or  $- \frac{1}{64}$  inch.

(3) To adjust the pump setting, bend the pump connector rod, using Tool T109-213, at the lower angle of rod, until the correct travel has been obtained.

### Fast Idle Speed and Cam Position Adjustment

The fast idle engine speed adjustment should be made on the engine, as described in the Fast Idle Speed Adjustment (On the engine) paragraph of this group, however, the Fast Idle Cam Position Adjustment can be made on the bench, as follows:

(1) With the fast idle speed adjusting screw contacting the lowest step on the fast idle cam, as shown in Figure 10, move the choke valve toward the closed position with light pressure. Insert a  $\frac{15}{64}$  inch drill or gauge between the choke valve and the wall of the air horn.

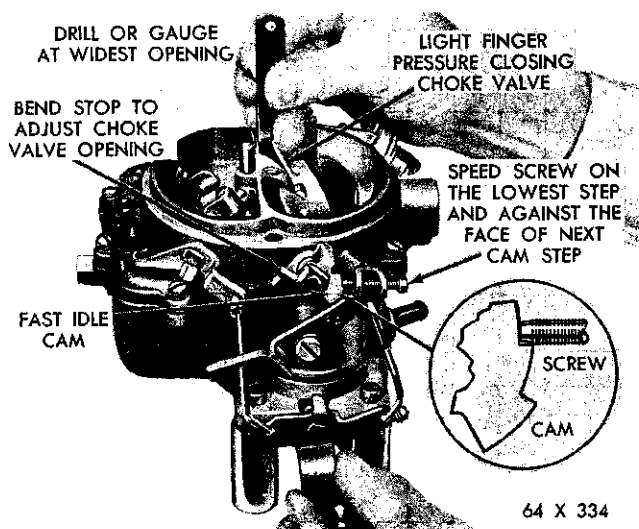

Fig. 10—Fast Idle Cam Position Adjustment

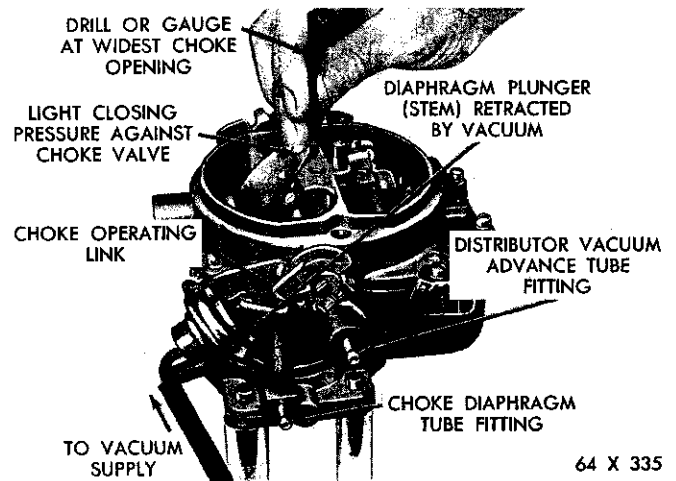

Fig. 11—Measuring the Choke Vacuum Kick Setting

(2) An adjustment will be necessary if a slight drag is not obtained as the drill or gauge is being removed.

(3) If an adjustment is necessary, bend the stop on the choke shaft, using Tool T109-22 until the correct valve opening has been obtained. (Refer to Fig. 10.)

**Vacuum Kick Adjustment**—(This test can be made On or Off the vehicle.)

To make the vacuum kick adjustment, the vacuum diaphragm must be energized (either a distributor testing machine with a vacuum source, or vacuum supplied by another vehicle). To make this adjustment, proceed as follows:

(1) With the engine **Not** running, open the throttle valves far enough to allow the choke valve to be moved to the closed position.

(2) Disconnect the vacuum hose from the diaphragm and connect the hose from the vacuum supply, as shown in Figure 11. (A minimum of 10 inches of mercury (HG) will be required.)

(3) Insert a  $\frac{11}{64}$  inch drill or gauge between the choke valve and the wall of the air horn (Refer to Fig. 11). Apply a slight closing pressure to the choke shaft to hold the drill or gauge in position.

(4) An adjustment will be necessary if a slight drag is not obtained as the drill or gauge is being removed.

The adjustment of this opening will require the removal of the choke operating link.

**CAUTION: DAMAGE TO THE DIAPHRAGM AND THE CHOKE LEVER SLOT CAN RESULT, IF THE LINK IS NOT REMOVED FOR THE BENDING OPERATION.**

(5) Remove the clip and disengage the choke operating link from the diaphragm stem (plunger), then disengage the link from the choke lever. (The

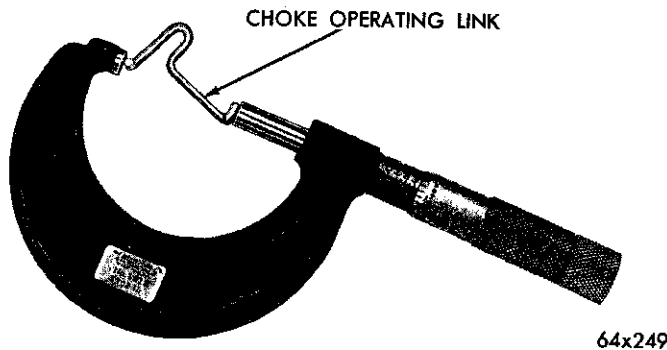

Fig. 12—Choke Operating Link Measurements

best bending results will be obtained by using a vise and a pair of pliers.)

(6) Bend the choke operating link to provide the correct choke valve opening.

**CAUTION:** A correction in the length of the link of .010 inch, will result in a change of .010 inch in the choke valve opening.

As an example, if the choke valve opening is .010 inch in error, the correction in the link length would be .010 inch.

A 2" micrometer will be helpful in establishing the original length of the link, as shown in Figure 12, before completing the adjustment.

(7) Install the choke operating link and retest the choke valve opening, using a gauge or drill. (Refer to Fig. 11.)

Reinstall the vacuum hose to the diaphragm and make the following test:

(8) With no vacuum applied to the diaphragm,

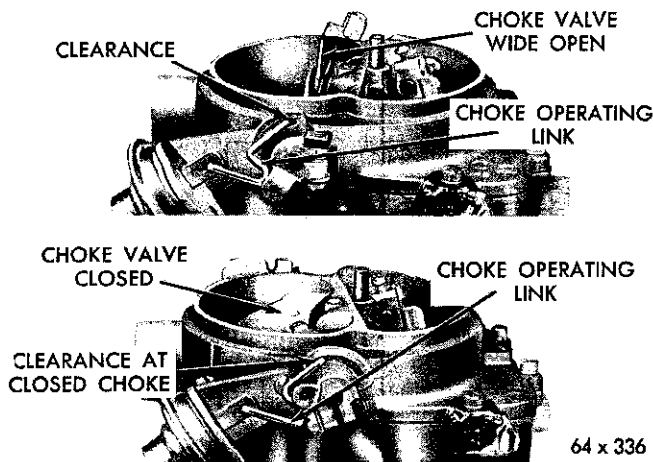

Fig. 13—Choke Operating Link Clearances

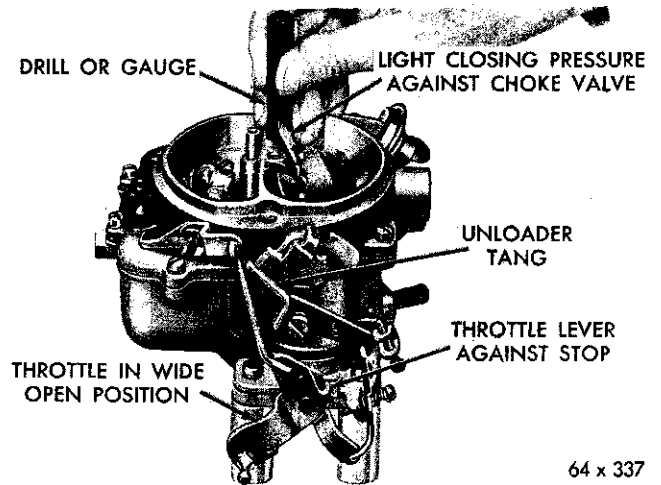

Fig. 14—Measuring the Choke Unloader Setting

some clearance should exist between the choke operating link and the choke lever slot, in both the open and closed choke valve positions, as shown in Figure 13.

**NOTE:** This clearance is necessary to allow the choke valve to close for starting as well as fully open position after the engine reaches the normal operating temperature.

If a clearance does not exist in both of these positions, a retest of the operating link adjustment should be made.

**NOTE:** Free movement of the choke valve between the closed and open positions is very necessary.

This free movement should also exist between the kick and the open choke valve positions with the engine running. If binding does exist, the choke operating link has been improperly bent and should be corrected.

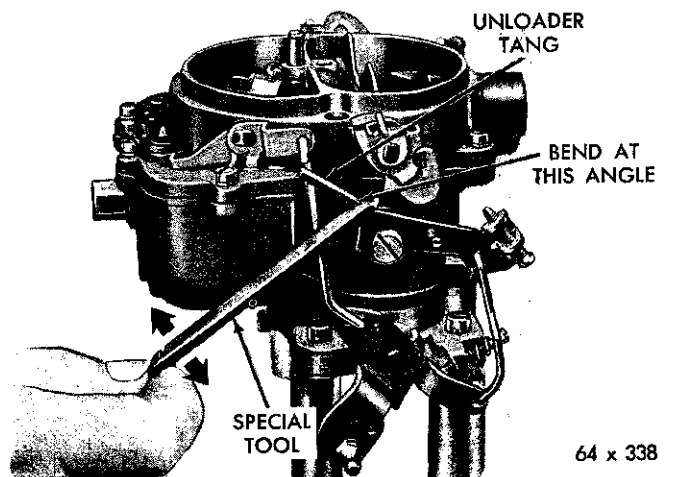

Fig. 15—Bending the Unloader Tang

**Choke Unloader (Wide Open Kick)**

(1) Hold the throttle valves in the wide open position. Insert Tool T109-31 or a ¼" drill shank between the upper edge of the choke valve and the inner wall of the air horn, as shown in Figure 14.

(2) With a finger lightly pressing against the valve, a slight drag should be felt as the gauge is being withdrawn. If an adjustment is necessary, bend the tang on the fast idle lever, using Tool T109-22, as shown in Figure 15, until the correct clearance has been obtained.

**Bowl Vent Valve Adjustment**

(1) With the throttle valves at curb idle, there should be ⅛ inch clearance between the bowl vent valve and the air horn, when measured (at the center of the vent valve and the seat) with a drill shank.

(2) If an adjustment is necessary, bend the short tang on the vent valve operating lever, using Tool T109-22 until the correct opening has been obtained.

**Idle Speed Adjustment (Curb Idle)**

To make the idle speed adjustment, the engine must be thoroughly warmed up. A more reliable idle adjustment can usually be obtained if the car has been driven a minimum of five miles. For best results, it is recommended that a tachometer be used in this adjustment.

On vehicles equipped with automatic transmission, loosen the nut in the sliding link of the carburetor to bellcrank rod so that the stop in the transmission will not interfere with the free movement of the carburetor throttle lever.

(1) To make the idle speed adjustment, turn the idle speed screw in or out to obtain 500 rpm. (On cars with air conditioning, set the idle speed at 500 rpm.) With air conditioning ON be sure the choke valve is fully open and that the fast idle adjusting screw is not contacting the fast idle cam.

(2) Turn each idle mixture screw in or out to obtain the highest rpm. While making the adjustment, carefully watch the tachometer and notice that the speed can be decreased by turning the screws in either direction from the setting that gave the highest rpm reading.

(3) Readjust to 500 rpm with the idle speed screw. (With air conditioning ON).

(4) Turn each idle mixture adjusting screw in the clockwise direction (leaner) until there is a slight drop in rpm. Turn each screw out, counterclockwise (richer) just enough to regain the lost rpm.

This procedure will assure that the idle has been set to the leanest mixture possible for smooth idle. **This setting is very important.**

Since the correct speed was originally set, using

the speed screw, the speed obtained after finding the leanest smooth idle will probably be too fast.

(5) Readjust the speed screw to obtain correct idle speed. Repeat steps 2 and 4 above if necessary.

After the proper idle speed has been obtained, move the sliding link to the rear against the stop and tighten the nut securely.

**5. MEASURING THE FLOAT SETTING OR FUEL LEVEL (On the Vehicle)**

To measure the float setting with the carburetor mounted on the engine, proceed as follows:

(1) Remove the hairpin clip and disengage the accelerator pump rod from the throttle lever and the pump rocker arm. Disconnect the automatic choke rod by unsnapping clip.

(2) Remove the air horn attaching screws and lift the air horn straight up and away from the main body. Remove the gasket.

(3) Set the float fulcrum pin by pressing a finger against the fulcrum pin retainer.

There should be enough fuel in the bowl to raise the floats so that the lip bears firmly against the needle. Additional fuel may be admitted by slightly depressing the float. If the fuel pressure in the line is insufficient to force the additional fuel into the bowl, add the necessary fuel from a clean container.

**WARNING:** Since the manifolds may be hot, it is dangerous to spill fuel onto these surfaces. Take the necessary precautions to avoid spillage.

(4) With only the pressure from the buoyant float holding the lip against the inlet needle, check the float setting, using Tool T109-282, or a "T" scale. There should be ¼ inch from the surface of the bowl (gasket removed) to the crown of the floats at the center.

If an adjustment is necessary, hold the floats on the bottom of the bowl, then bend the float lip toward or away from the needle. Recheck the ¼ inch setting again, then repeat the lip bending operation as required.

**CAUTION:** When bending the float lip, do not allow the lip to push against the needle as the rubber tip can be compressed sufficiently to cause a false setting which will affect correct level of fuel in the bowl.

**NOTE:** After being compressed, the rubber tip is very slow to recover its original shape. It is very important that the float lip be perpendicular to the needle or slanted not more than 10 degrees away from the needle when the float is set correctly.

(5) After the float has been correctly set, reassemble the air horn.

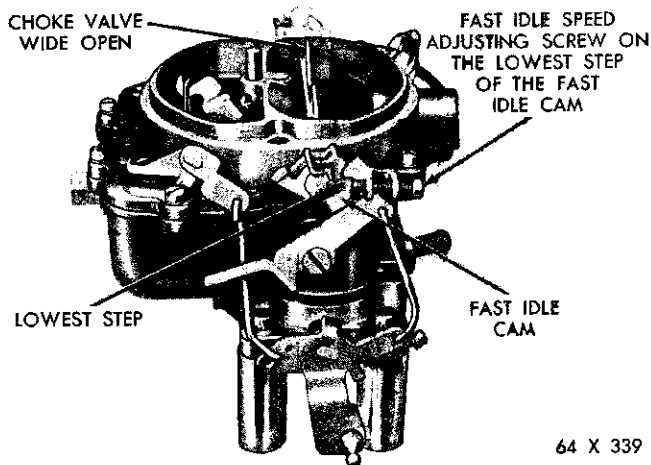

Fig. 16—Fast Idle Speed Adjustment (On the Engine)

**Fast Idle Speed Adjustment (On the Engine)**

To set the fast idle speed on the engine, connect a tachometer to the vehicle, then set the curb idle speed and proceed as follows:

- (1) With the engine running and the transmission in the neutral position, open the throttle slightly.
- (2) Close the choke valve about 20 degrees then allow the throttle to close. Return the choke valve to the open position.
- (3) The fast idle adjusting screw should be contacting the lowest step on the fast idle cam, as shown in Figure 16.
- (4) With the engine warmed-up to the normal operating temperature, turn the fast idle adjusting screw in or out to secure 700 rpm. **Reposition the cam and throttle after each adjustment.**

**6. AUTOMATIC CHOKE—WELL TYPE**

To function properly, it is important that all parts be clean and move freely. Other than an occasional cleaning, the choke requires no servicing. It is very important, however, that the choke control unit work freely in the well and at the choke shaft.

Move the choke rod up and down to check for free movement on the pivot. If the unit binds, a new

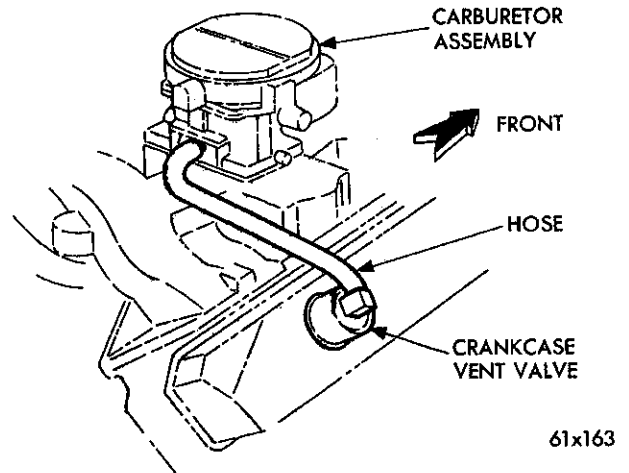

Fig. 17—Closed Crankcase Vent System

choke unit should be installed. **THE WELL TYPE CHOKE UNIT** is serviced as an assembly. Do not attempt to repair or change the index setting.

When installing the well type choke unit, be certain that the coil housing does not contact the sides of the well in the intake manifold. Any contact at this point will affect choke operation.

**Do not lubricate** any parts of the choke or the control unit. This causes an accumulation of dirt which will result in binding of the choke mechanism.

**9. CLOSED CRANKCASE VENT SYSTEM**

The closed crankcase ventilator valve is located in the crankcase vent tube cap and is connected to the carburetor throttle body with a rubber tube. (See Fig. 17.)

The function of the valve is to regulate the flow of unburned hydrocarbons from the crankcase and return them to the intake manifold. From here they enter the combustion chamber and then exit with the exhaust system as completely burned exhaust products. For servicing procedures of this system, refer to "Engine," Group 9.

**10. THROTTLE LINKAGE**

To adjust the throttle linkage refer to Figure 18 for the complete instructions.

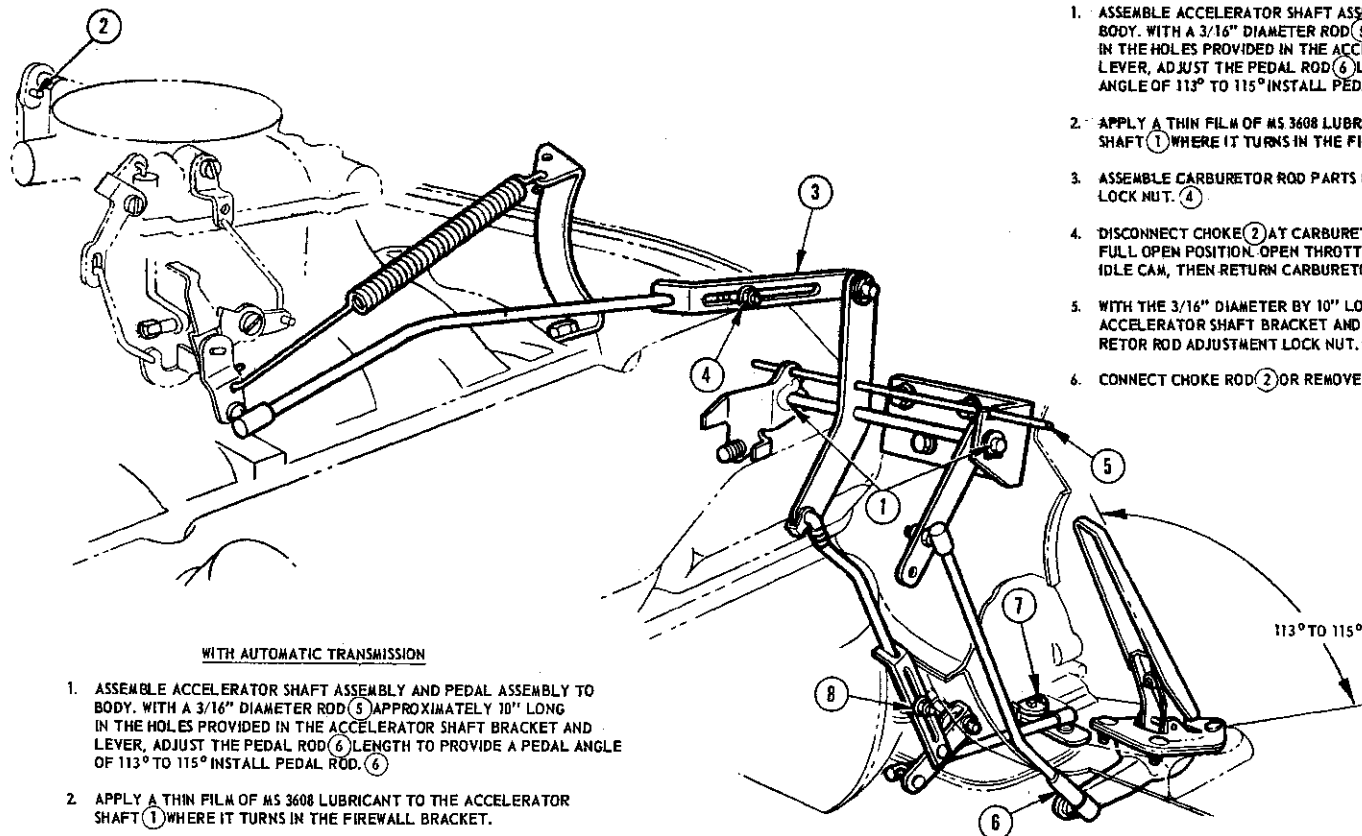

#### WITH AUTOMATIC TRANSMISSION

1. ASSEMBLE ACCELERATOR SHAFT ASSEMBLY AND PEDAL ASSEMBLY TO BODY. WITH A 3/16" DIAMETER ROD (5) APPROXIMATELY 10" LONG IN THE HOLES PROVIDED IN THE ACCELERATOR SHAFT BRACKET AND LEVER, ADJUST THE PEDAL ROD (6) LENGTH TO PROVIDE A PEDAL ANGLE OF 113° TO 115° INSTALL PEDAL ROD. (6)
2. APPLY A THIN FILM OF MS 3608 LUBRICANT TO THE ACCELERATOR SHAFT (1) WHERE IT TURNS IN THE FIREWALL BRACKET.
3. ASSEMBLE CARBURETOR ROD PARTS BUT DO NOT TIGHTEN ADJUSTMENT LOCK NUT. (4)
4. DISCONNECT CHOKE (2) AT CARBURETOR OR BLOCK CHOKE VALVE IN FULL OPEN POSITION. OPEN THROTTLE SLIGHTLY TO RELEASE FAST IDLE CAM, THEN RETURN CARBURETOR TO CURB IDLE.
5. WITH THE TRANSMISSION ROD ASSEMBLY AND TRANSMISSION THROTTLE LEVER IN PLACE, MOVE THE TRANSMISSION THROTTLE LEVER (7) FORWARD AGAINST THE STOP AND TIGHTEN TRANSMISSION ROD ADJUSTMENT LOCK NUT. (8) REMOVE 3/16" DIAMETER ROD (5) FROM ACCELERATOR SHAFT BRACKET.

#### WITH MANUAL TRANSMISSION

1. ASSEMBLE ACCELERATOR SHAFT ASSEMBLY AND PEDAL ASSEMBLY TO BODY. WITH A 3/16" DIAMETER ROD (5) APPROXIMATELY 10" LONG IN THE HOLES PROVIDED IN THE ACCELERATOR SHAFT BRACKET AND LEVER, ADJUST THE PEDAL ROD (6) LENGTH TO PROVIDE A PEDAL ANGLE OF 113° TO 115° INSTALL PEDAL ROD. (6)
2. APPLY A THIN FILM OF MS 3608 LUBRICANT TO THE ACCELERATOR SHAFT (1) WHERE IT TURNS IN THE FIREWALL BRACKET.
3. ASSEMBLE CARBURETOR ROD PARTS BUT DO NOT TIGHTEN ADJUSTMENT LOCK NUT. (4)
4. DISCONNECT CHOKE (2) AT CARBURETOR OR BLOCK CHOKE VALVE IN FULL OPEN POSITION. OPEN THROTTLE SLIGHTLY TO RELEASE FAST IDLE CAM, THEN RETURN CARBURETOR TO CURB IDLE.
5. WITH THE 3/16" DIAMETER BY 10" LONG ROD (5) IN PLACE IN THE ACCELERATOR SHAFT BRACKET AND LEVER ASSEMBLY, TIGHTEN CARBURETOR ROD ADJUSTMENT LOCK NUT. (4)
6. CONNECT CHOKE ROD (2) OR REMOVE BLOCKING FIXTURE.

6. MOVE REAR PORTION OF CARBURETOR ROD ASSEMBLY (3) REARWARD UNTIL TRANSMISSION THROTTLE LEVER (7) STOP IS CONTACTED. TIGHTEN CARBURETOR ROD ADJUSTMENT LOCK NUT. (4)
7. CONNECT CHOKE ROD (2) OR REMOVE BLOCKING FIXTURE.

63x367

Fig. 18—Throttle Linkage Adjustments



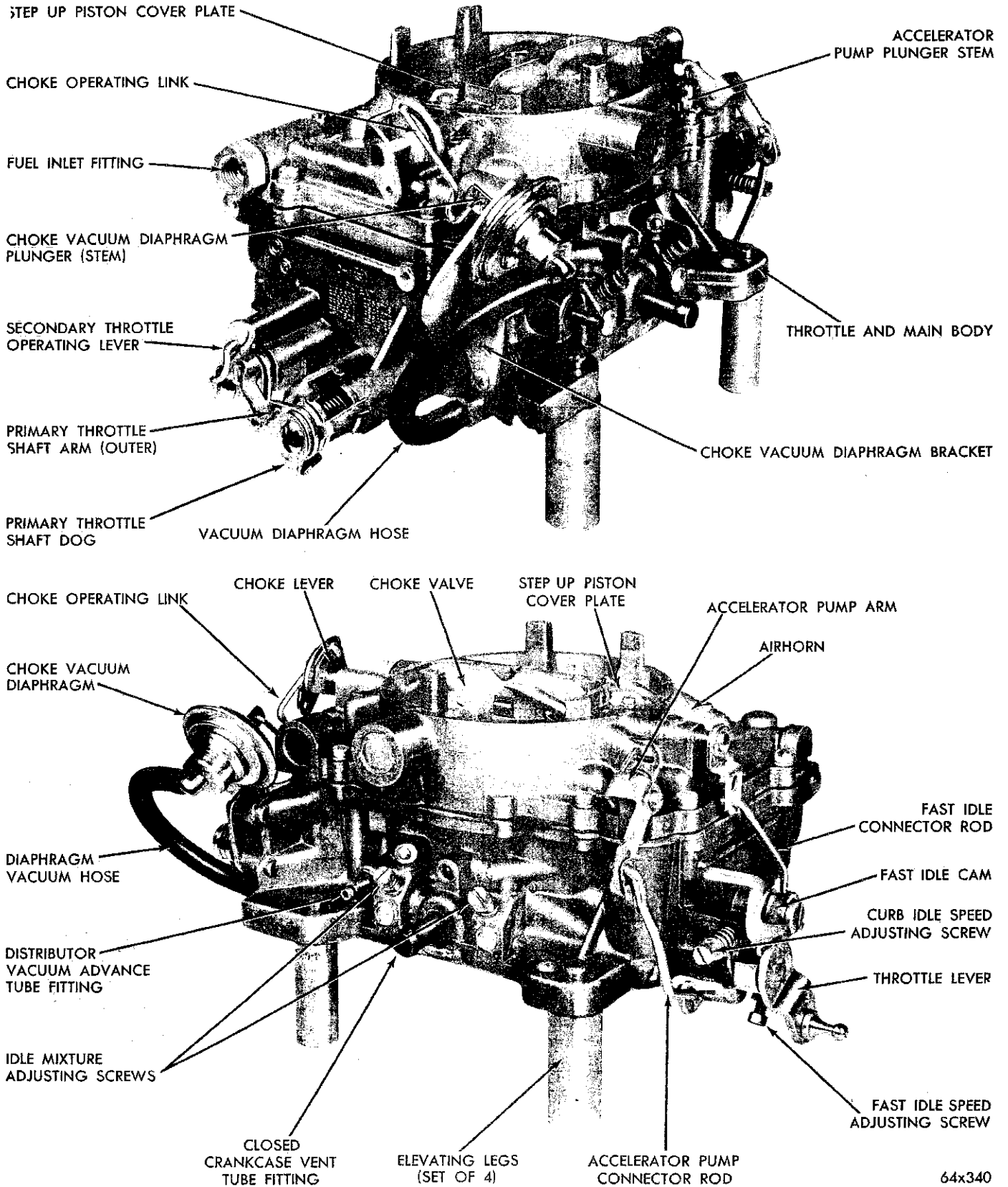

64x340

Fig. 1—Carburetor Assembly (AFB Series)

## PART 3

# AFB CARBURETORS

The AFB (aluminum four barrel) carburetor contains many features, some of which are the location for the step-up rods and pistons. The step-up rods, pistons and springs are accessible for service without removing the air horn, or the carburetor from the engine.

The venturi assemblies (primary and secondary) are replaceable and contain many of the calibration points for both the high and low speed system. One fuel bowl feeds both the primary and secondary nozzles on the right side while the other fuel bowl takes care of the primary and secondary nozzles on

the left side. This provides improved performance in cornering, quick stops and acceleration.

All the major castings of the carburetor are aluminum, with the throttle body cast integral with the main body. This allows an overall height reduction in the carburetor. The section containing the accelerator pump is termed the primary side of the carburetor. The rear section is the secondary.

The five conventional systems are two float systems, two low speed systems (primary side only), two high speed systems, one accelerator pump system and one automatic choke control system.

## SERVICE PROCEDURES

### 1. SERVICING THE CARBURETOR

Dirt, dust, water and gummy deposits are some of the main causes for poor carburetor operation. However, proper cleaning and the installation of new parts, where required, will return the carburetor to its originally designed performance.

When overhauling the AFB carburetor, several items of importance should be observed to assure a good job.

The carburetor should be carefully disassembled and all parts (except the choke diaphragm assembly) should be cleaned in a suitable solvent and inspected for wear or damage.

Air pressure only should be used to clean the various orifices and channels. Replace questionable parts with new ones.

### 2. DISASSEMBLING THE CARBURETOR (Fig. 1)

(1) Place the carburetor assembly on repair stand Tool C-3400 or T-109-287S elevating legs.

(2) Remove the hairpin clip that attaches the fast idle connector rod to the choke lever. Disengage rod from lever, then swing rod at an arc until it can be disengaged from the fast idle cam.

(3) Remove the retainer and spring that holds the throttle connector rod in the center hole of the accelerator pump arm. Remove the hairpin clip that attaches the lower end of rod in the primary throttle shaft lever. Disengage rod from arm and lever, then remove from carburetor.

(4) Remove the vacuum hose between the carburetor body and the vacuum diaphragm.

(5) Remove the clip from the choke operating link and disengage the link from the diaphragm plunger (stem) and the choke lever. (Refer to Fig. 1.)

(6) Remove the vacuum diaphragm and bracket assembly and place to one side to be cleaned as a separate item. **A liquid cleaner may damage the diaphragm material.**

(7) Remove the screws attaching the step-up piston and rod cover plates.

**NOTE:** Hold cover down with a finger to prevent the piston and rods from flying out.

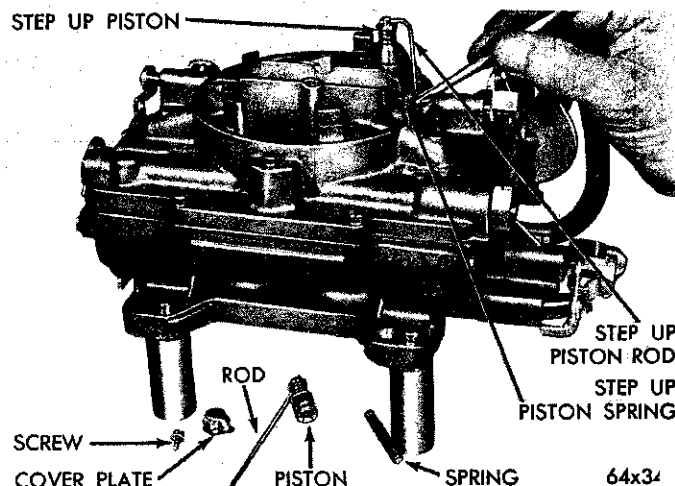

Fig. 2—Removing Step-up Pistons and Rods

(8) Lift off the plates and slide the step-up pistons and rods out of the air horn, as shown in Figure 2. Remove the step-up piston springs.

(9) Remove the ten screws that attach the air horn to the main body (1 screw in hole in air horn). Lift air horn straight up and away from the main body.

**NOTE:** When removing air horn, use care so as not to bend or damage the floats.

(10) Remove the accelerator pump plunger lower spring from the pump cylinder.

### Disassembling the Air Horn

Place the air horn in an inverted position on the bench (to protect the floats).

(1) Using a suitable tool, remove the float fulcrum pins (left and right) and lift the floats up and out of bosses on air horn.

**NOTE:** It is suggested that the float on the pump side be marked so that the floats can be re-installed in their respective positions.

(2) Remove the two needle valves from their respective seats, after marking the one on the pump side for identification. Using a wide blade screw driver, remove the needle valve seats. Be sure each needle valve is returned to its original seat at re-assembly.

(3) Remove the hairpin clip that holds the accelerator pump connector link in the pump arm and plunger shaft. Disengage link from pump arm and shaft. Slide the accelerator pump plunger and spring out of the air horn. Remove the air horn to main body gasket and discard.

(4) Place the accelerator pump plunger in a jar of clean gasoline or kerosene, to prevent the leather from drying out.

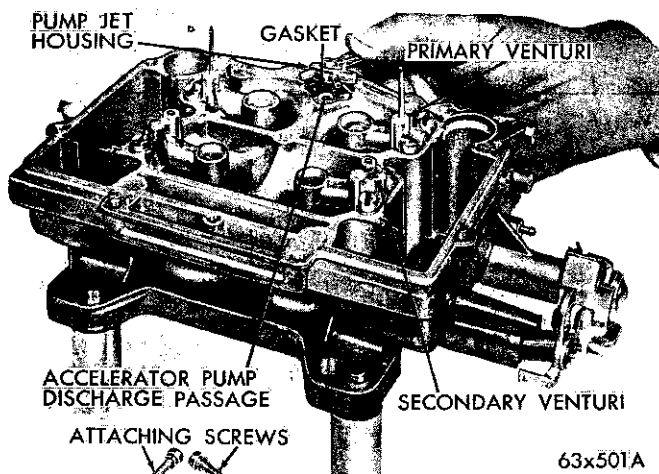

Fig. 3—Removing Accelerator Pump Jet Housing

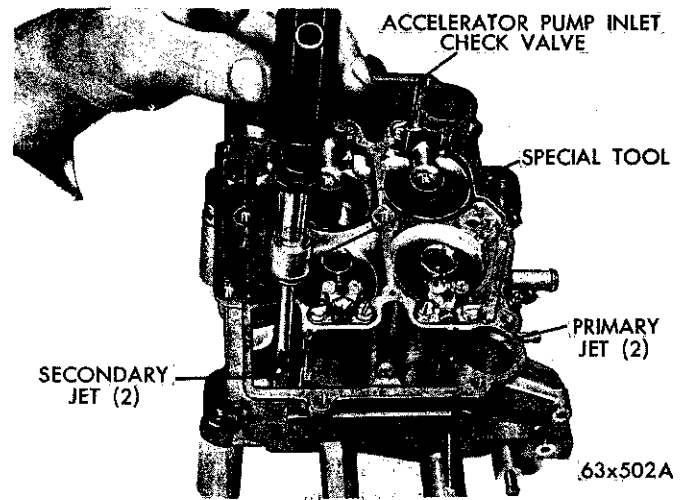

Fig. 4—Removing Main Metering Jets

(5) Remove the fuel inlet fitting and filter screen from the air horn.

(6) Test the freeness of the choke mechanism in the air horn. The choke shaft must float free to operate correctly. If the choke shaft sticks in the bearings, or appears to be gummed from deposits in the air horn, a thorough cleaning will be required.

### Main Body Disassembly

(1) Remove the screws that attach the accelerator pump jet housing to the main body. Lift out the jet housing and gasket, as shown in Figure 3. Discard the gasket. Invert the main body and drop out the discharge check needle from the discharge passage.

(2) Using Tool T109-58 remove the main metering jets (secondary side), as shown in Figure 4.

**NOTE:** The primary and secondary main metering jets are not interchangeable. It is very important that these jets be installed in their respective locations in the main body at reassembly.

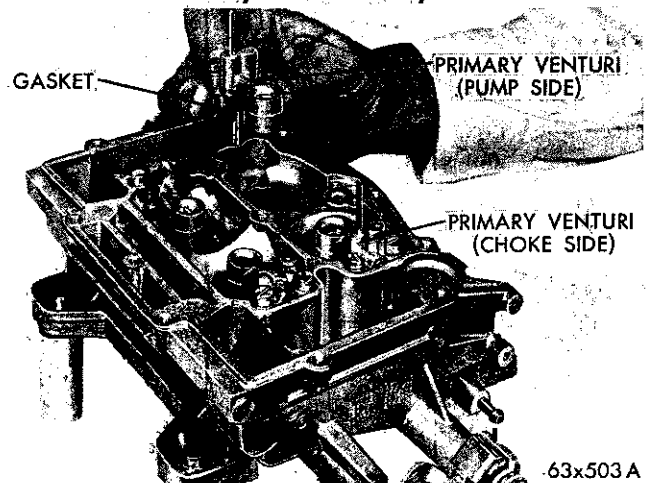

Fig. 5—Removing Primary Venturi

(3) Using Tool T-109-58, remove the main metering jets (primary side).

(4) Remove the screws that attach the primary venturi (choke and pump side) to the main body. Lift the venturi straight up and away from the main body, as shown in Figure 5. Discard the gaskets.

**NOTE:** The venturi assemblies are not interchangeable, side for side and must be re-installed in their original location at reassembly.

(5) Remove the screws that attach the secondary venturi (choke and pump side) to the main body. Lift the secondary venturi assemblies straight up and away from the body, as shown in Figure 6.

(6) Using Tool T-109-59, screw driver bit, remove the accelerator pump intake check ball assembly. (The check ball assembly is located at the front of the bowl at the base of the accelerator pump cylinder. Be sure that the check ball is thoroughly cleaned before installation.

(7) Remove the two idle mixture adjusting screws and springs from the throttle body portion of the main casting.

The carburetor now has been disassembled into two units, the air horn and main and throttle body casting. The component parts of each have been disassembled as far as necessary for cleaning and inspection.

It is usually not advisable to remove the throttle shafts or valves, unless wear or damage necessitates

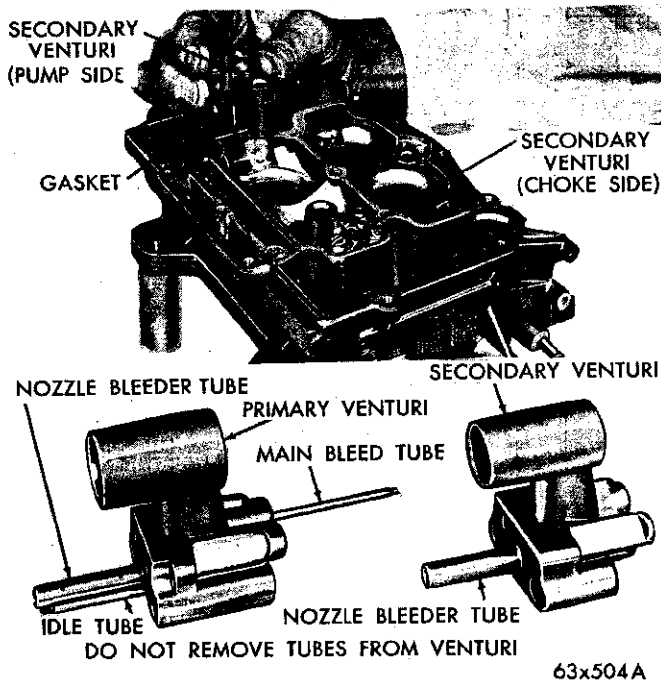

Fig. 6—Removing Secondary Venturi

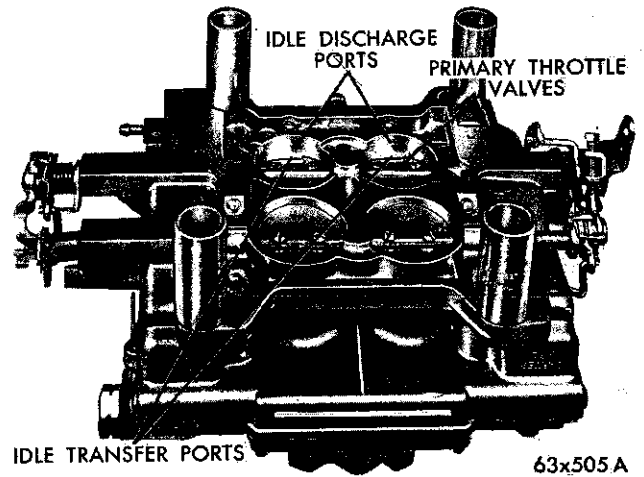

Fig. 7—Ports in Relation to Throttle Valves

the installation of new parts. During the manufacture of the carburetor, the location of the idle transfer ports and the idle discharge ports to the valve is carefully established for one particular assembly, as shown in Figure 7. The valves are milled to give the proper port relation.

If new throttle shafts should be installed in an old, worn body, it would be very unlikely that the original relationship of these ports to the valves would be obtained. A very slight change in the port relationship to the valves would adversely affect normal carburetor operation, between the speeds of 15 and 30 miles per hour.

It is recommended that if the throttle shafts are excessively worn, that a new carburetor be installed. If the throttle valves, however, have become nicked, burred or damaged, new valves may be installed, providing the following instructions are carefully followed:

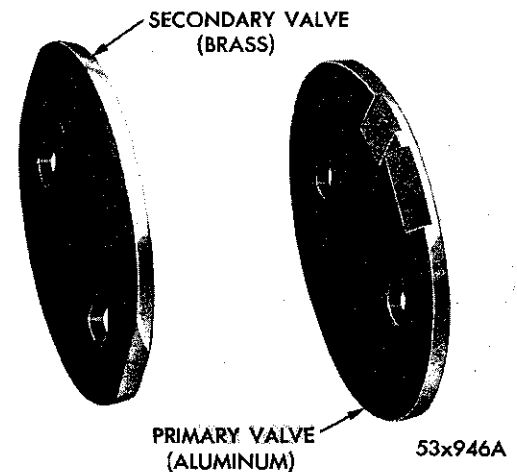

Fig. 8—Throttle Valve Identification

**NOTE:** The screws that attach the throttle valves are staked on the opposite side and care should be used in removal so as not to break the screws in the throttle shaft. Remove the staked portion of the screws with a file.

Remove the screws that attach the primary throttle valves to the throttle shaft and slide valve (or valves) out of the bores.

Remove the screws that attach the secondary throttle valves to the throttle shaft and slide valve (or valves) out of the bores.

The primary valves and secondary valves are not interchangeable and should be kept separate in order that each may be returned to its respective bore. (See Fig. 8.)

### 3. CLEANING THE CARBURETOR PARTS

The recommended solvent for gum deposits is denatured alcohol. There are other commercial solvents, however, which may be used with satisfactory results.

The choke diaphragm can be damaged by solvents. Avoid placing the diaphragm assembly in any liquid. Clean the external surfaces with a clean cloth or soft wire brush. Shake dirt or other foreign material from the stem side of the diaphragm. Depressing the diaphragm stem to the retracted position, will provide an additional hole for the removal of dirt. Compressed air can be used to remove loose dirt, but should not be connected to the vacuum inlet fitting.

**IMPORTANT:** If the commercial solvent or cleaner recommends the use of a water rinse, it should be "HOT." After rinsing, all trace of water must be blown from the passages with air pressure. It is further advisable to rinse all parts in clean kerosene or gasoline to be certain no trace of moisture remains. Never clean jets with a wire, drill, or other mechanical means, because the orifices may become enlarged, making the mixture too rich for proper performance.

### 3. INSPECTION AND REASSEMBLY

#### *Main and Throttle Body Casting*

(1) Slide the primary throttle valve (or valves) into their respective bores, install new screws, but do not tighten. Be sure the idle speed adjusting screw is backed out. Hold the valves in place with fingers (fingers pressing on the high side of the valves).

(2) Tap the valves lightly with a screw driver to seat in the bores. Holding the valves in this position, tighten the screws securely. Stake screws by squeezing with pliers.

(3) Install the two idle mixture adjusting screws and springs in the throttle body portion of the casting.

The tapered portion must be smooth and straight. If the tapered portion is grooved or ridged, a new idle mixture adjusting screw should be installed to insure having correct idle mixture control.

**NOTE:** Do not use a screw driver.

The adjustment should be made with the fingers. Turn the idle mixture adjusting screws lightly against their seats and back off one full turn for an approximate adjustment.

(4) Place the new secondary venturi gaskets in position (bleed hole in top, toward the center of the carburetor), install the secondary venturi (pump and choke side) by lowering straight down on the gaskets. Install the attaching screws and tighten securely.

**NOTE:** Be sure all the metering holes and vent tubes are clean, in both the primary and secondary venturi.

(5) Place new primary venturi gaskets in position, then install the primary venturi (pump and choke side) by lowering straight down on the gaskets. (See Fig. 5.) Install attaching screws and tighten securely.

(6) Install the primary and secondary main metering jets, using Tool T109-58. (See Fig. 4.) Tighten jets securely.

(7) Install the accelerator pump intake check ball assembly in position in the carburetor bowl. Tighten securely, using Tool T109-59.

#### **Accelerator Pump Test**

(1) Pour clean gasoline into the carburetor bowl (approximately ½ inch deep). Remove the accelerator pump plunger from the jar of gasoline. Flex the leather several times, then slide it on the pump cylinder.

(2) Install the accelerator pump discharge check needle in the discharge passage. Raise the pump plunger and press lightly on the plunger shaft to expel air from the pump passages. Using a small clean brass rod, hold the discharge check needle firmly on its seat. Again raise the plunger and press downward. No fuel should be emitted from either the intake or discharge passage.

(3) If fuel does emit from the intake passage, disassemble the intake check ball and reclean the passage. Fuel leakage at the discharge check needle indicates the presence of dirt or a damaged check needle. Clean again and then install a new check needle. Retest for leakage.

(4) If either the intake check ball or discharge check needle leaks after above test and service fix, attempt to reseat as follows:

**Intake Check Ball**

Remove the accelerator pump check ball assembly and install a new check ball assembly.

**Discharge Check Needle**

(1) With the discharge check needle installed, insert a piece of drill rod down on the needle. Lightly tap the drill rod with a hammer to form a new seat. Remove and discard old needle and install a new one. Retest as described previously. If the service fix does not correct the condition, a new carburetor must be installed.

(2) Install the accelerator pump discharge check needle, jet housing and gasket. Install housing and attaching screws. Tighten screws securely.

(3) Press down on the accelerator pump plunger shaft and as the plunger is being depressed, a clear straight stream should emit from each jet. If the streams are identical (if either one is diverted or restricted) a new accelerator pump jet housing should be installed. After test, pour the gasoline from the carburetor bowl and remove pump plunger.

**Air Horn Assembly**

(1) Slide the fuel inlet screen into the fuel line fitting, then install fitting in air horn. Tighten securely.

(2) Inspect to see if the leather on the accelerator pump plunger is hard, cracked or worn. If any sign of wear or deterioration is evident, install a new plunger assembly.

(3) When reassembling, make sure the large diameter of the pivot screw enters the hole in the pump arm and that the shoulder of the screw has not pinched the pump arm.

(4) Place a new air horn to main body gasket in position on the air horn and install the float needle valve seats. (Be sure each needle seat and needle is reinstalled in its original position.)

The carburetors are equipped with synthetic rubber-tipped fuel inlet needle. The rubber tip is flexible enough to make a good seal on the needle seat, and to give increased resistance to flooding.

**NOTE:** The use of the rubber-tipped needles require that care be used when making float adjustments. Avoid applying any pressure on the floats which might compress the tip of the fuel inlet needles. The rubber tip can be compressed sufficiently to cause a false setting which will affect correct level of fuel in the bowl.

(5) Slide the right and left floats into position in the air horn and install the float fulcrum pins.

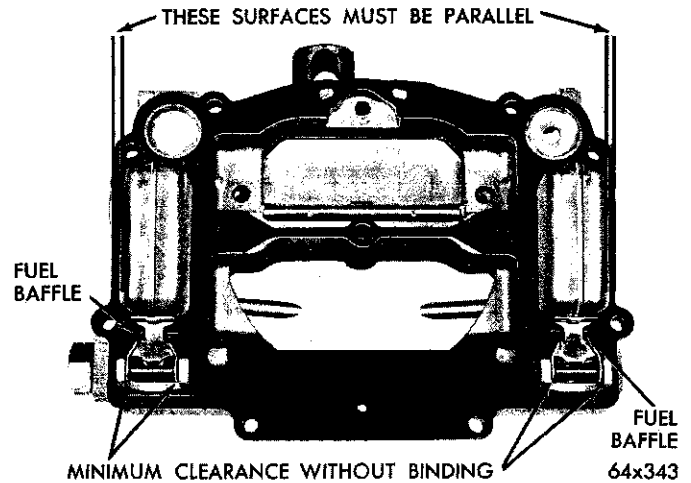

Fig. 9—Measuring the Float Alignment

**NOTE:** Be sure the marked float is installed on the pump side of the air horn.

(6) After the floats have been installed, test the float alignment, level and drop settings as follows:

**Float Alignment Setting**

(1) Sight down the side of each float shell to determine if the side of the float is parallel to the outer edge of the air horn casting, as shown in Figure 9.

(2) If the sides of the float are not in alignment with the edge of casting, bend the float lever by applying pressure to the end of the float shell with the fingers while supporting the float lever with the thumb.

**NOTE:** To avoid damage to the float, apply only enough pressure to bend the float lever.

(3) The arms of the float lever should be parallel to the inner surfaces of the lugs or the casting.

**Float Level Setting**

(1) With the air horn inverted, the air horn gasket

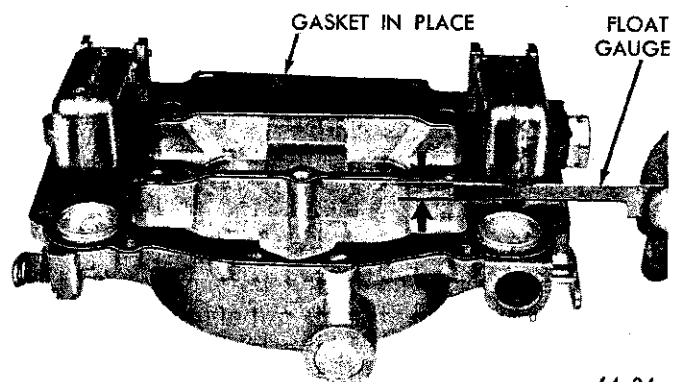

Fig. 10—Measuring the Float Height

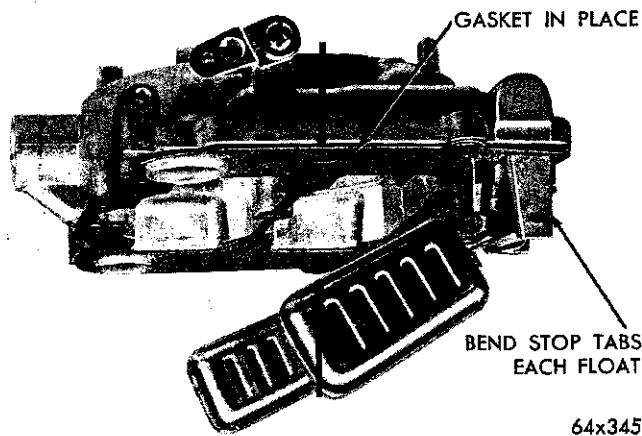

Fig. 11—Measuring the Float Drop

in place and the float needle seated, slide the float gauge Tool T109-106 ( $\frac{1}{32}$ " ) between the top of the float (at outer end) and the air horn gasket, as shown in Figure 10.

(2) Measure the other float in the same manner. If an adjustment is necessary, bend the float arm using Tool T109-22, until correct clearance has been obtained. After bending arm, recheck the float alignment.

### Float Drop Setting

(1) Holding the air horn in an upright position, measure the distance from the top of the floats (outer end) to the air horn gasket, as shown in Figure 11. This measurement should be  $\frac{3}{4}$  inch. If an adjustment is necessary, bend the stop tabs on the float levers until the correct drop setting has been obtained. Bend the tab towards the needle seat to lessen the drop, or away from the seat to increase the drop.

(2) After the floats have been inspected and adjusted, continue to assemble the carburetor as follows:

(3) Place the accelerator pump plunger lower spring in the pump cylinder, then lower the air horn carefully down on the main body.

**CAUTION:** Be sure the fuel baffles on the air horn, slide down in front (bowl side) of the float chamber baffles, or the air horn will not index correctly with the main body and can cause the floats to hang up. Be sure the leather on the plunger does not curl or wrinkle. Accelerator pump operation will be affected if this precaution is not observed.

(4) Install the (10) air horn attaching screws and tighten securely. (The two long screws should be installed in the holes that are located at the air cleaner mounting surface. The 1 inch screw at the front and the  $1\frac{1}{2}$  inch at the rear.)

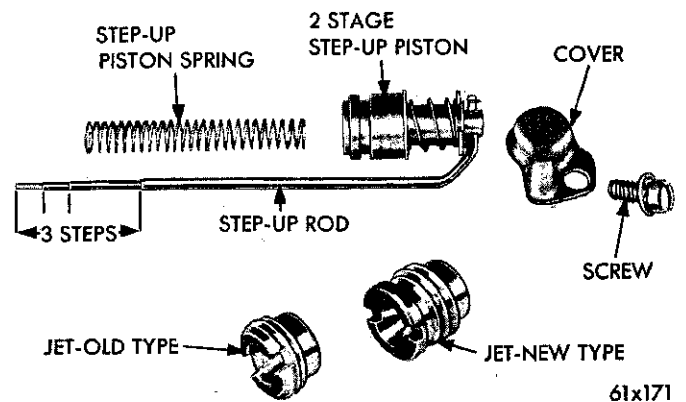

Fig. 12—Step-up Piston, Rod and Jet

The change from the low speed, best fuel economy, road load mixtures to the richer wide open throttle pull mixtures is accomplished in two steps. This has made it possible to secure best low speed fuel economy without sacrificing performance in the intermediate speed range. To do this, there is a new step-up piston and spring assembly, new metering rods with three diameters, and new style primary metering jets, as shown in Figure 12.

(5) Slide the step-up piston springs into the piston cylinders, followed by the step-up pistons and step-up rods. Install the cover plates and attaching screws while holding the step-up pistons down in position. Tighten screws securely.

(6) Slide the choke piston into its cylinder in the air horn, guiding the link into the slot in the choke valve lever. Align hole, then install attaching cotter pin. Place a new welch plug over the cylinder opening and secure by rapping with a hammer. (Be sure the sealing surface is clean.) Check the fit of the choke valve in air horn. The valve should be evenly spaced on all sides. Loosen screws and reposition, if necessary.

(7) Engage the throttle connector rod with the primary throttle shaft lever and install hairpin clip. Install the other end of the connector rod in the pump arm and secure with clevis clip.

(8) Engage the lower end of the fast idle connector rod with the fast idle cam, then swing in an arc to lock in cam. Slide other end of rod into the choke shaft lever and secure with hairpin clip.

### Installing the Vacuum Diaphragm

(1) Install the vacuum diaphragm assembly on the main body and tighten the attaching screws securely.

(2) Install the choke operating link in position between the diaphragm plunger (stem) and the choke lever. Install the clip to secure.

(3) Inspect the vacuum diaphragm fitting and remove any dirt or foreign material which could clog the passage. Inspect the rubber hose for cracks, before placing it on the correct throttle body fitting. (Refer to Fig. 1.)

Do not connect the vacuum hose to the diaphragm fitting until after the vacuum kick adjustment has been made. (See Carburetor Adjustments.)

#### 4. CARBURETOR ADJUSTMENTS

The adjustments are made with the carburetor on the bench for ease of working, and should be made in the following order:

##### Fast Idle Speed and Cam Position Adjustment

The fast idle engine speed adjustment should be made on the engine, as described in the Fast Idle Speed Adjustment (On the engine) paragraph of this group, however, the Fast Idle Cam Position Adjustment can be made on the bench.

(1) Open the throttle valves far enough to allow the fast idle speed adjusting screw to clear the fast idle cam.

(2) Insert a  $\frac{5}{32}$  inch drill or gauge between the choke valve and the air horn wall, as shown in Figure 13.

(3) Close the throttle valves until the fast idle speed adjusting screw contacts the fast idle cam.

(4) Adjust the fast idle connector rod, using Tool T109-213 by bending at the angle until the fast idle speed adjusting screw lightly contacts the **middle step** on the fast idle cam, but slides onto the **bottom** step of the cam. The fast idle speed adjusting screw must

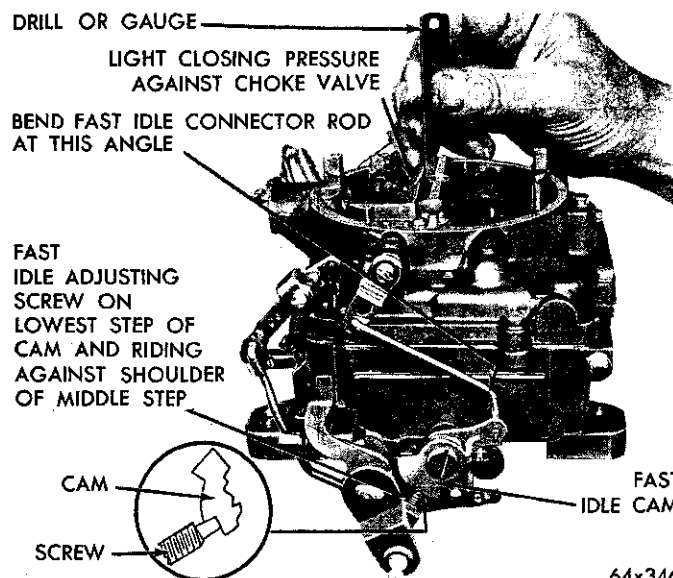

Fig. 13—Fast Idle Cam Position Adjustment

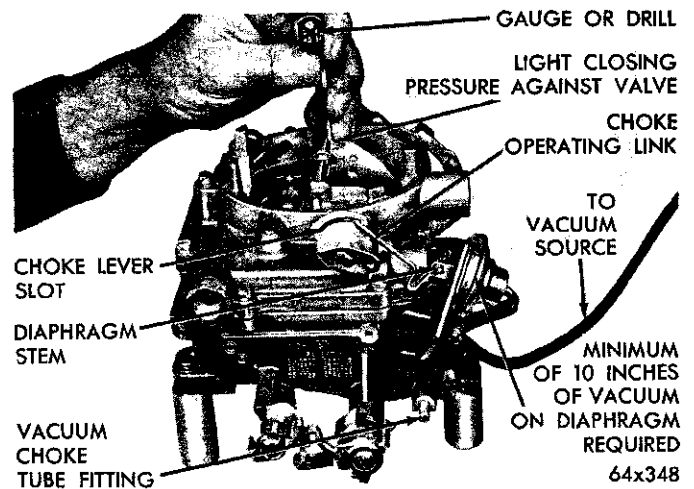

Fig. 14—Measuring the Choke Vacuum Kick Setting

touch or ride against the shoulder of the middle step on the cam.

(This special procedure is required because the fast idle speed cam is spring loaded to follow the choke valve.)

**Vacuum Kick Adjustment**—(This test can be made ON or Off the vehicle.)

To make the vacuum kick adjustment, the vacuum diaphragm must be energized (either a distributor testing machine with a vacuum source, or vacuum supplied by another vehicle.) To make this adjustment, proceed as follows:

(1) With the engine **Not** running, open the throttle valves far enough to allow the choke valve to be moved to the closed position.

(2) Disconnect the vacuum hose from the diaphragm and connect the hose from the vacuum supply, as shown in Figure 14. (A minimum of 10 inches of mercury (HG) will be required.)

(3) Insert a  $\frac{1}{8}$  inch drill or gauge between the choke valve and the wall of the air horn. (Refer to Fig. 14.) Apply a slight closing pressure to the choke shaft to hold the drill or gauge in position.

(4) An adjustment will be necessary if a slight drag is not obtained as the drill or gauge is being removed.

The adjustment of this opening will require the removal of the choke operating link.

**CAUTION: DAMAGE TO THE DIAPHRAGM AND THE CHOKE LEVER SLOT CAN RESULT, IF THE LINK IS NOT REMOVED FOR THE BENDING OPERATION.**

(5) Remove the clip and disengage the choke operating link from the choke lever, then disengage the link from the diaphragm stem. (The best bending



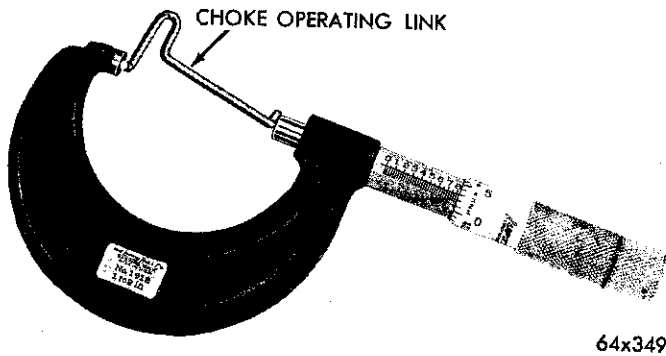

Fig. 15—Choke Operating Link Measurement

results will be obtained by using a vise and a pair of pliers.)

(6) Bend the choke operating link to provide the correct choke valve opening.

**CAUTION:** A correction in the length of the link of .015 inch, will result in a change of .010 inch in the choke valve opening.

As an example, if the choke valve opening is .010 inch in error, the correction in the link length would be .015.

A 2" micrometer will be helpful in establishing the original length of the link, as shown in Figure 15, before completing the adjustment.

(7) Install the choke operating link and retest the choke valve opening, using a drill or gauge. (Refer to Fig. 14.)

Reinstall the vacuum hose to the diaphragm and make the following test:

(8) With no vacuum applied to the diaphragm, some clearance should exist between the choke operating link and the choke lever slot, in both the open and closed choke valve positions, as shown in Figure 16.

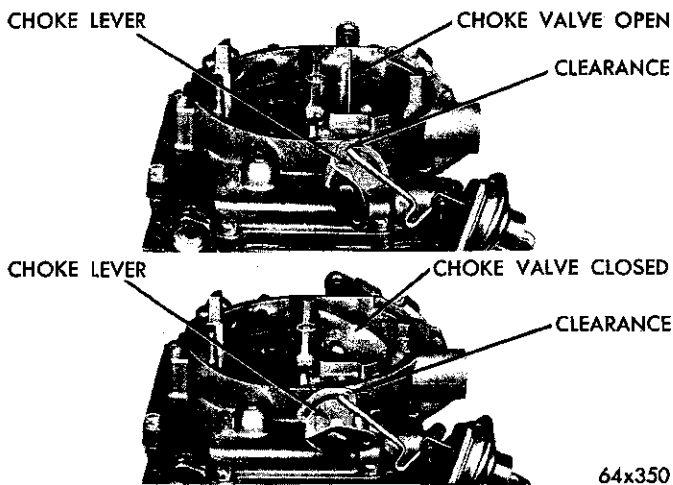

Fig. 16—Choke Operating Link Clearances

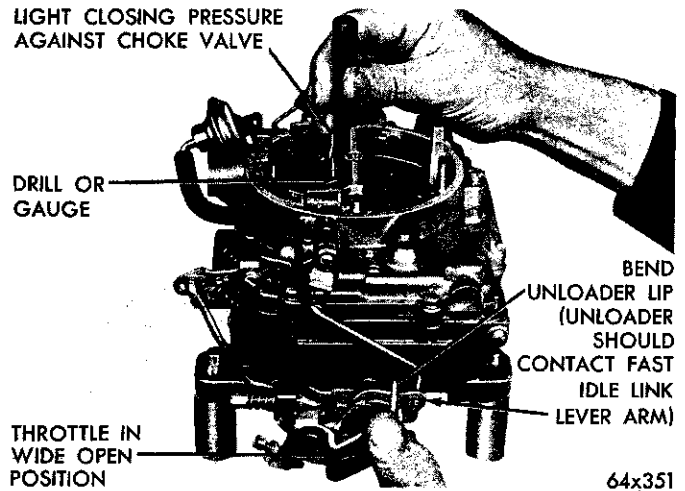

Fig. 17—Testing Choke Unloader (Wide Open Kick)

**NOTE:** This clearance is necessary to allow the choke valve to close for starting as well as fully open after the engine reaches the normal operating temperature.

If a clearance does not exist in both of these positions, a retest of the operating link adjustment should be made.

**NOTE:** Free movement of the choke valve between the closed and open positions is very necessary.

This free movement should also exist between the kick and the open choke valve positions with the engine running. If binding does exist, the choke operating link has been improperly bent and should be corrected.

**Choke Unloader Adjustment**

(1) With the throttle valves in the wide open position, it should be possible to insert Tool T109-80 (3/8 inch) gauge between the upper edge of the choke valve and the inner wall of the air horn, as shown in Figure 17.

(2) If an adjustment is necessary, bend the unloader lip on the throttle shaft lever, using Tool T109-41, until correct opening has been obtained.

**Accelerator Pump Adjustment**

(1) Move the choke valve to wide open position, to release the fast idle cam. Back off the idle speed adjusting screw, (curb idle) until the throttle valves are seated in the bores.

(2) Measure the distance from the top of the air horn to the top of the plunger shaft, using a "T" scale as shown in Figure 18. This distance should be 7/16 inch.

(3) If an adjustment is necessary, bend the throttle connector rod at the lower angle, using Tool T-109-213, until correct travel has been obtained.

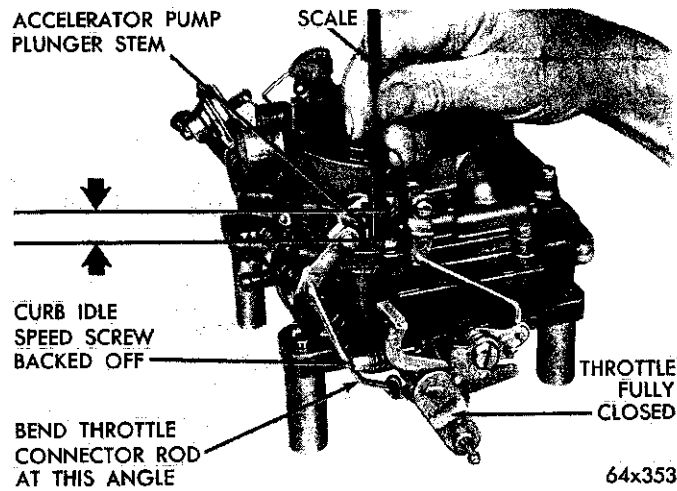

Fig. 18—Testing the Accelerator Pump Adjustment

**Secondary Throttle Lever Adjustment**

(1) To measure the secondary throttle lever adjustment, block the choke valve in the wide open position and invert the carburetor.

(2) Slowly open the primary throttle valves until it is possible to measure  $2\frac{1}{4}$  inch between the lower edge of the primary valve and the bore (opposite idle port) as shown in Figure 19. At this measurement, the secondary valves should just start to open.

(3) If an adjustment is necessary, bend the secondary throttle operating rod at the angle, using Tool T109-213, until correct adjustment has been obtained.

(4) With the primary and secondary throttle valves in the tightly closed position, it should be possible to insert Tool T109-29 (.020 inch) wire gauge, between the positive closing shoes on the secondary throttle levers, as shown in Figure 20.

(5) If an adjustment is necessary, bend the shoe on the secondary throttle lever, using Tool T109-22, until correct clearance has been obtained.

**Secondary Throttle Lock-out Adjustment**

(1) Open the throttle valves slightly, then manually open and close the choke valve. The tang on the secondary throttle lever should freely engage in the notch of the lock-out dog. (Refer to Fig. 19.)

(2) If an adjustment is necessary, bend the tang on the secondary throttle lever, until engagement has been made. Use Tool T109-22 for this operation.

(3) After adjustments have been made, reinstall carburetor on engine, using a new gasket.

(4) It is suggested that the carburetor bowl be filled with clean gasoline. This will help prevent dirt that is trapped in the fuel system from being dis-

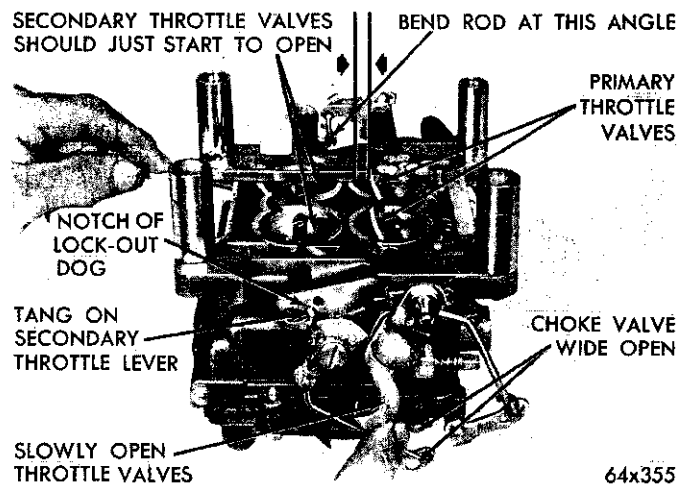

Fig. 19—Testing the Secondary Throttle Adjustment

lodged by the free flow of fuel, as the carburetor is primed.

**Idle Speed Adjustment (Curb Idle)**

To make the idle speed adjustment, the engine must be thoroughly warmed up. A much more reliable idle adjustment can usually be obtained if the car has been driven a minimum of five miles. For the best results, it is recommended that a tachometer be used in this adjustment. (Before making the idle speed adjustment, observe the following precautions:)

On cars equipped with the automatic transmission loosen the nut in the sliding link of the carburetor to bellcrank rod so that the stop in the transmission will not interfere with the free movement of the carburetor throttle lever.

(1) To make the idle speed adjustment, turn the idle speed screw in or out to obtain 500 rpm. (On cars with air conditioning, set the idle speed at 500

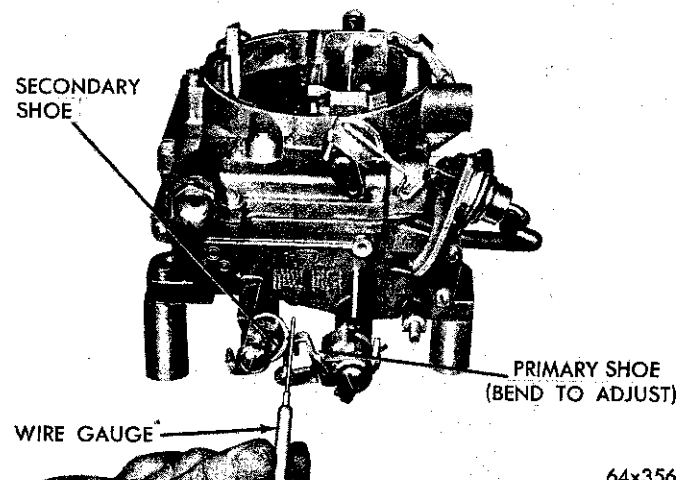

Fig. 20—Measuring Clearance Between Closing Shoes

64x355

64x356

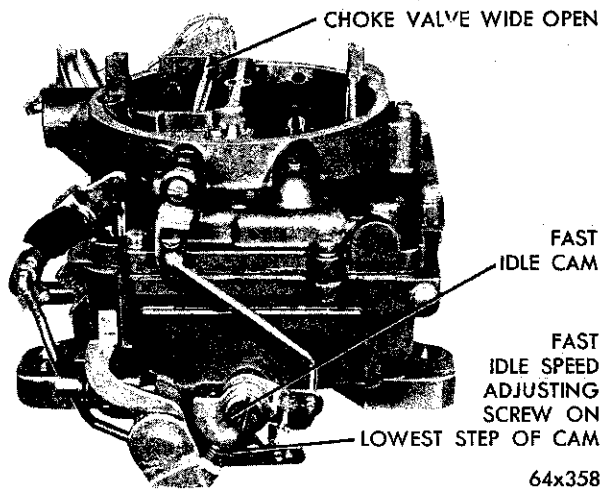

Fig. 21—Fast Idle Speed Adjustment (On the Engine)

rpm.) Be sure the choke valve is fully open and that the fast idle adjusting screw is not contacting the fast idle cam.

(2) Turn each idle mixture screw to obtain the highest rpm. While making the adjustment, carefully watch the tachometer and notice that the speed can be decreased by turning the screws in either direction from the setting that gave the highest rpm. reading.

(3) Readjust to 500 rpm. with the idle speed screw. (Air conditioning ON).

(4) Turn each idle mixture adjusting screw in the clockwise direction (leaner) until there is a slight drop in rpm. Turn each screw out, counter-clockwise (richer) just enough to regain the lost rpm.

This procedure will assure that the idle has been set to the leanest possible mixture for smooth idle. **This setting is very important.**

**NOTE:** Since the correct speed was originally set using the speed screw, the speed obtained after finding the leanest smooth idle setting will probably be too fast.

(5) Readjust the speed screw to obtain correct idle speed. Repeat steps 2 and 4 above if necessary.

After the proper idle speed has been obtained, move the sliding link to the rear, against the stop, and tighten the nut securely.

### Fast Idle Speed Adjustment (On the Engine)

To set the fast idle speed on the engine, connect a tachometer to the vehicle, then set the curb idle speed and proceed as follows:

(1) With the engine running and the transmission in the neutral position, open the throttle slightly.

(2) Close the choke valve about 20 degrees, then

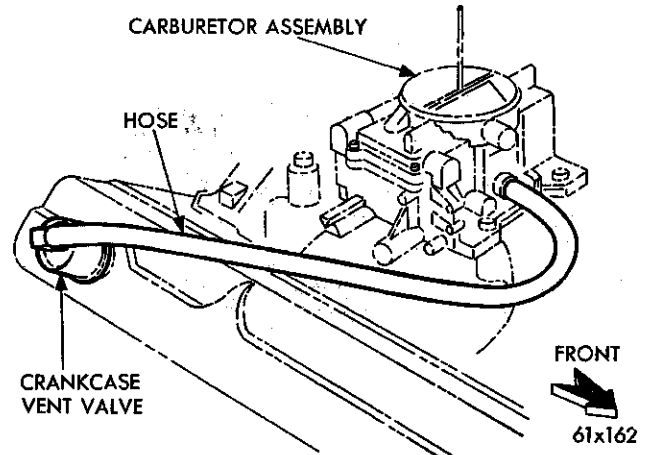

Fig. 22—Closed Crankcase Vent System

allow the throttle to close. Return the choke valve to the wide open position.

(3) The fast idle speed adjusting screw should be contacting the lowest step on the fast idle cam, as shown in Figure 21.

(4) With the engine warmed-up to the normal operating temperature, turn the fast idle speed adjusting screw in or out to secure 700 rpm. **Reposition the cam and throttle after every fast idle speed screw adjustment.**

### 5. AUTOMATIC CHOKE (Well Type)

To function properly, it is important that all parts be clean and move freely. Other than the occasional cleaning, the automatic choke control requires no servicing. It is very important, however, that the choke control unit moves freely at the thermostatic coil spring housing and at the choke shaft. Move the choke rod up and down to check for free movement of the coil housing on the pivot. If unit binds, a new unit should be installed. **The Well Type Choke Control Unit is serviced only as a complete unit. Do not attempt to repair.**

Do not lubricate any parts of the choke or control unit since this causes dirt accumulation which would result in binding of the choke mechanism.

Do not attempt to change the calibration setting. (Refer to specifications.) This is pre-determined and should it be changed, improper action would result.

Clean all choke parts using a suitable solvent and then blow dry with compressed air. Examine all choke parts for wear or damage. Worn or damaged parts must be replaced with new in order to insure proper choke operation.

When installing the well type choke unit, make certain that the coil housing does not contact the

## **14-36 AFB CARBURETOR**

---

sides of the wall in the intake manifold. Any contact at this point will affect operation.

### **6. CLOSED CRANKCASE VENT SYSTEM**

The closed crankcase ventilator valve is located in the crankcase vent tube cap and is connected to the carburetor throttle body via a rubber tube. (See Fig. 22.) The function of the valve is to regulate the flow of unburned hydrocarbons from the crankcase and return them to the intake manifold. From here they

enter the combustion chamber and then exit via the exhaust system as completely burned exhaust products.

For servicing procedures of this system, refer to the "Engine section" Group 9.

### **7. THROTTLE LINKAGE**

To adjust the throttle linkage, refer to Figure 23 for the complete instructions.

---

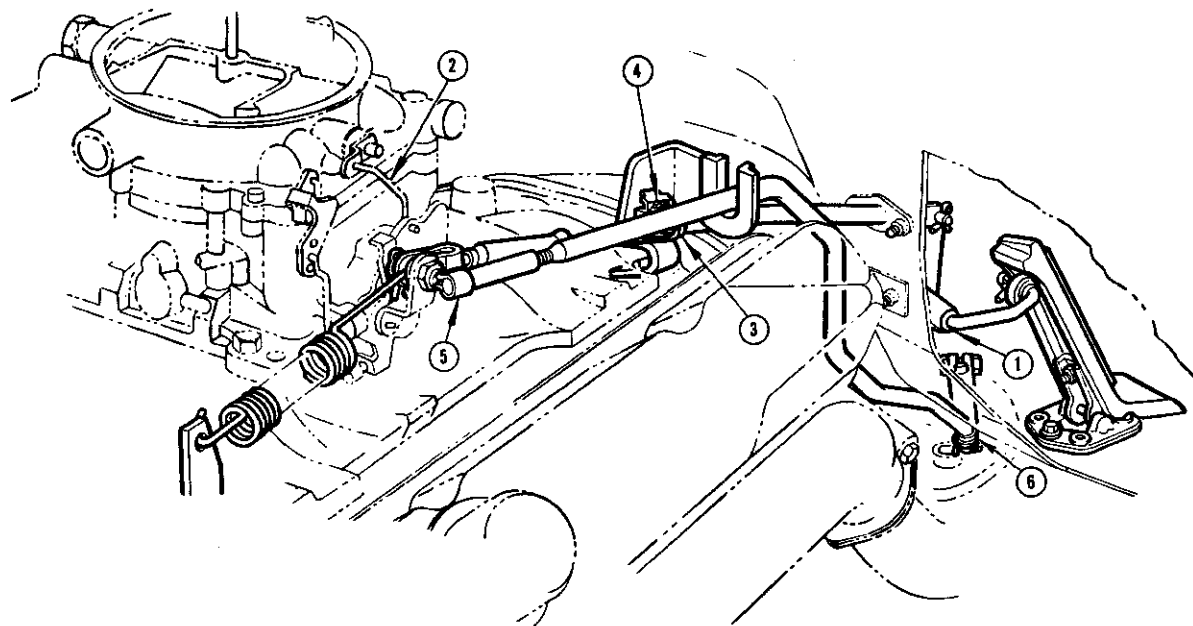

1. ASSEMBLE TRANSMISSION CONTROL LINKAGE PARTS IN PLACE BUT DO NOT ASSEMBLE TRANSMISSION ROD BALL SOCKET (5) TO BALL END.
2. APPLY A THIN FILM OF MS 3701 LUBRICANT TO THE ACCELERATOR SHAFT (1) WHERE IT TURNS IN THE BRACKET.
3. DISCONNECT CHOKE (2) AT CARBURETOR OR BLOCK CHOKE VALVE IN FULL OPEN POSITION, OPEN THROTTLE SLIGHTLY TO RELEASE FAST IDLE CAM, THEN RETURN CARBURETOR TO CURB IDLE.
4. HOLD THE TRANSMISSION LEVER (6) FORWARD AGAINST ITS STOP AND ADJUST THE LENGTH OF THE TRANSMISSION ROD BY MEANS OF THE THREADED ADJUSTMENT (5) AT THE UPPER END. THE BALL SOCKET MUST LINE UP DIRECTLY WITH THE BALL END WITHOUT EXERTING ANY FORWARD FORCE ON THE ROD. THE BALL SOCKET MUST BE AT THE SAME HEIGHT AS THE BALL END WHEN CHECKING ROD LENGTH.
5. LENGTHEN ROD BY ONE TURN OF THE ADJUSTMENT. (5)
6. ASSEMBLE BALL SOCKET (5) TO BALL END. WHEN THE CARBURETOR THROTTLE IS OPENED, THE TRANSMISSION SHOULD BEGIN ITS TRAVEL AT THE SAME TIME WITH NO VERTICAL MOVEMENT OF THE LEVER OR VERTICAL MOVEMENT OF THE ROD IN THE LEVER.
7. ASSEMBLE REMAINDER OF THE LINKAGE PARTS IN PLACE. WITH THE CABLE CLAMP NUT (4) LOOSE, ADJUST THE POSITION OF THE CABLE HOUSING FERRULE (3) IN THE CLAMP SO THAT ALL SLACK IS REMOVED FROM THE CABLE WITH THE CARBURETOR AT CURB IDLE. TO REMOVE SLACK FROM THE CABLE, MOVE THE FERRULE (3) IN THE CLAMP IN THE DIRECTION AWAY FROM THE CARBURETOR LEVER.
8. BACK OFF FERRULE (3) 1/2". THIS PROVIDES 1/2" FREE PLAY BETWEEN THE REAR SURFACE OF THE ACCELERATOR BRKT. AND THE FRONT EDGE OF ACCELERATOR SHAFT LEVER. TIGHTEN CLAMP NUT (4)
9. ROUTE CABLE SO THAT IT DOES NOT INTERFERE WITH THE TRANSMISSION ROD THROUGHOUT ITS FULL TRAVEL.
10. CONNECT CHOKE ROD (2) OR REMOVE BLOCKING FIXTURE.

64 x 422

Fig. 23—Throttle Linkage Adjustments (Imperial)

## PART 4

## FIRE POWER 390 FUEL AND INDUCTION SYSTEM

The Chrysler Fire Power 390 engine, as shown in Figure 1, is equipped with twin air cleaners, twin AFB carburetors, hand type chokes and two aluminum

manifolds, containing eight sweeping passages (four in each manifold), all of which employ a new method of fuel induction.

## SERVICE PROCEDURES

## 1. INTAKE MANIFOLDS

**Removal (Fig. 2)**

- (1) Drain the cooling system.
- (2) Remove the carburetor air cleaners.
- (3) Disconnect the fuel line between the fuel pump and the left hand carburetor.
- (4) Disconnect the fuel line between the left and right hand carburetor. Disconnect the choke control.
- (5) Disconnect the vacuum line between the right hand carburetor and the distributor.
- (6) Remove the high tension coil wire.
- (7) Disconnect the throttle linkage at both carburetors and the bell crank, to the accelerator shaft.
- (8) Loosen the clamps that attach the equalizer tube couplings to the manifolds, and to the equalizer tube. Slide either coupling inward on the tube far enough to clear the manifold tube opening. Lift the equalizer tube, couplings and clamps up and away from engine.
- (9) Disconnect the power steering hoses (if so equipped) at the pump and secure against the fire wall.

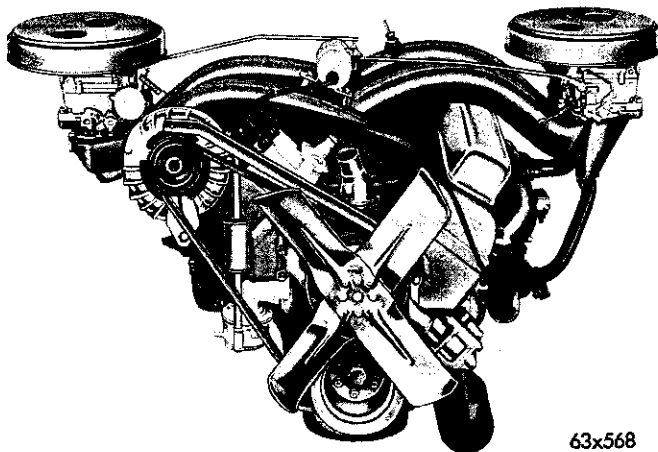

63x568

Fig. 1—Fire Power Manifold

- (10) Remove the air conditioning compressor and brackets, (if so equipped). Refer to Air Conditioning Section.

- (11) Remove the eight attaching bolts that hold the left fender shield access plate to fender shield, then slide plate out of the engine compartment.

- (12) Remove the two bolts that attach the left hand by-pass pipe to the lower chamber.

- (13) Remove the two bolts that attach the left hand exhaust manifold elbow to the lower chamber. Discard the gaskets.

- (14) Remove the four bolts that attach the intake manifold to the right bank cylinder head. Remove the exhaust passage crossover cover.

- (15) Lift the intake manifold and carburetor from the engine as an assembly.

- (16) Remove the nuts that attach the carburetor to the intake manifold. Remove the carburetor.

- (17) Remove the eight attaching bolts that hold the right fender shield access plate to the fender shield, then slide plate out of engine compartment.

- (18) Remove the two bolts that attach the right hand exhaust by-pass pipe to the lower chamber.

- (19) Remove the two bolts that attach the right hand exhaust manifold elbow to the lower chamber. Discard the gaskets.

- (20) Remove the four bolts that attach the intake manifold to the left bank cylinder head. Remove the exhaust passage crossover cover.

- (21) Lift the manifold and carburetor from the engine as an assembly.

- (22) Remove the nuts that attach the carburetor to the intake manifold, then disconnect the automatic choke rod from the lever. Remove the carburetor.

**Installation**

When installing the intake manifolds be sure and use new gaskets and be sure all mating surfaces are smooth and clean.

To install the left hand intake manifold, refer to Figure 2, then proceed as follows:

(1) Place the carburetor in position on the mounting pad of the intake manifold and engage the choke control. Install the carburetor mounting nuts and tighten.

(2) Place the intake manifold assembly in position on the right hand bank cylinder head. Place the exhaust crossover passage cover over the passage, then install the manifold attaching bolts finger tight.

(3) Slide a new gasket between the left hand exhaust manifold elbow and the lower chamber of the intake manifold. Install attaching bolts finger tight.

(4) Slide a new gasket between the left hand exhaust by-pass pipe and the manifold lower chamber. Install the attaching bolts and tighten to 10 foot-pounds. Tighten the elbow attaching bolts to 10 foot-pounds and the intake manifolds bolts to 50 foot-pounds.

(5) Slide the left hand fender shield access plate into position against fender shield. Install bolts and tighten.

If both intake manifolds were removed, continue to install the right hand manifold as follows:

(6) Place the carburetor in position on the mounting pad of the intake manifold and connect the choke control. Install the carburetor mounting nuts and tighten.

(7) Place the intake manifold assembly in position on the left hand bank cylinder head. Place the exhaust crossover passage cover over the passage, then install the manifold attaching bolts finger tight.

(8) Slide a new gasket between the right hand exhaust manifold elbow and the lower chamber of the intake manifold. Install attaching bolts finger tight.

(9) Slide a new gasket between the right hand exhaust by-pass pipe and the lower chamber. Install attaching bolts and tighten to 10 foot-pounds. Tighten the elbow attaching bolts to 10 foot-pounds and the intake manifold bolts to 50 foot-pounds.

(10) Slide the right hand fender shield access plate into position against fender shield. Install bolts and tighten.

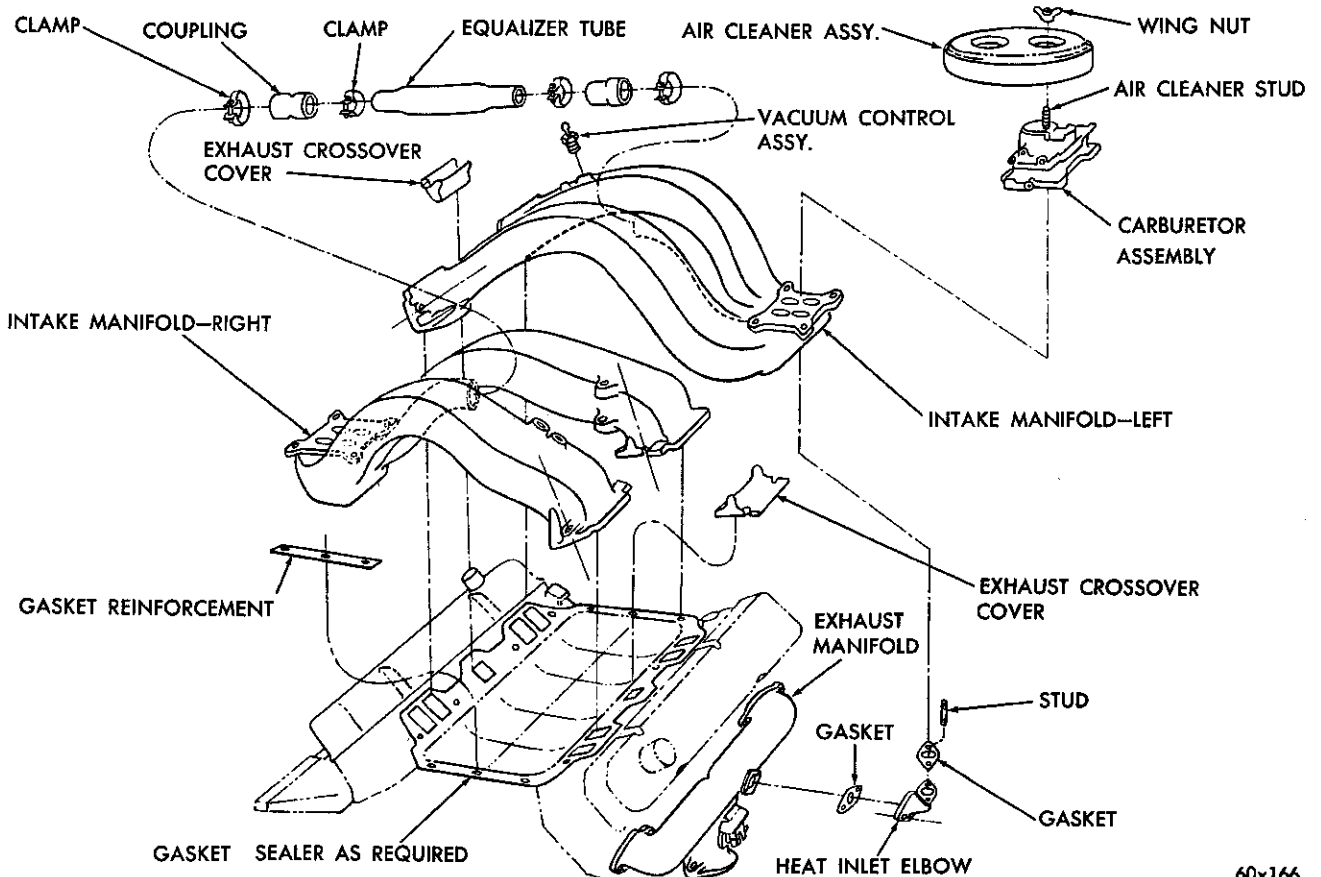

Fig. 2—Fire Power Manifold (Disassembled)

**14-40 FUEL AND INDUCTION SYSTEM**

(11) Place the air conditioning compressor and brackets in position (if so equipped) and install attaching bolts. Tighten securely. (Refer to the Air Conditioning Group 24 for method of recharging the system.)

(12) Reconnect the Power Steering hoses to the pump (if so equipped). (Refer to Power Steering Group 19 for method of bleeding air out of the system.)

(13) Slide the equalizer tube, clamps and couplings over the manifold tubes. Slide either coupling outward

far enough to firmly engage the manifold. Tighten clamps securely.

(14) Reconnect the throttle linkage at both carburetor and bell-crank to accelerator shaft.

(15) Reinstall the high tension coil wire.

(16) Reconnect the vacuum line between the carburetor and distributor.

(17) Reconnect the fuel line between the left and right hand carburetors.

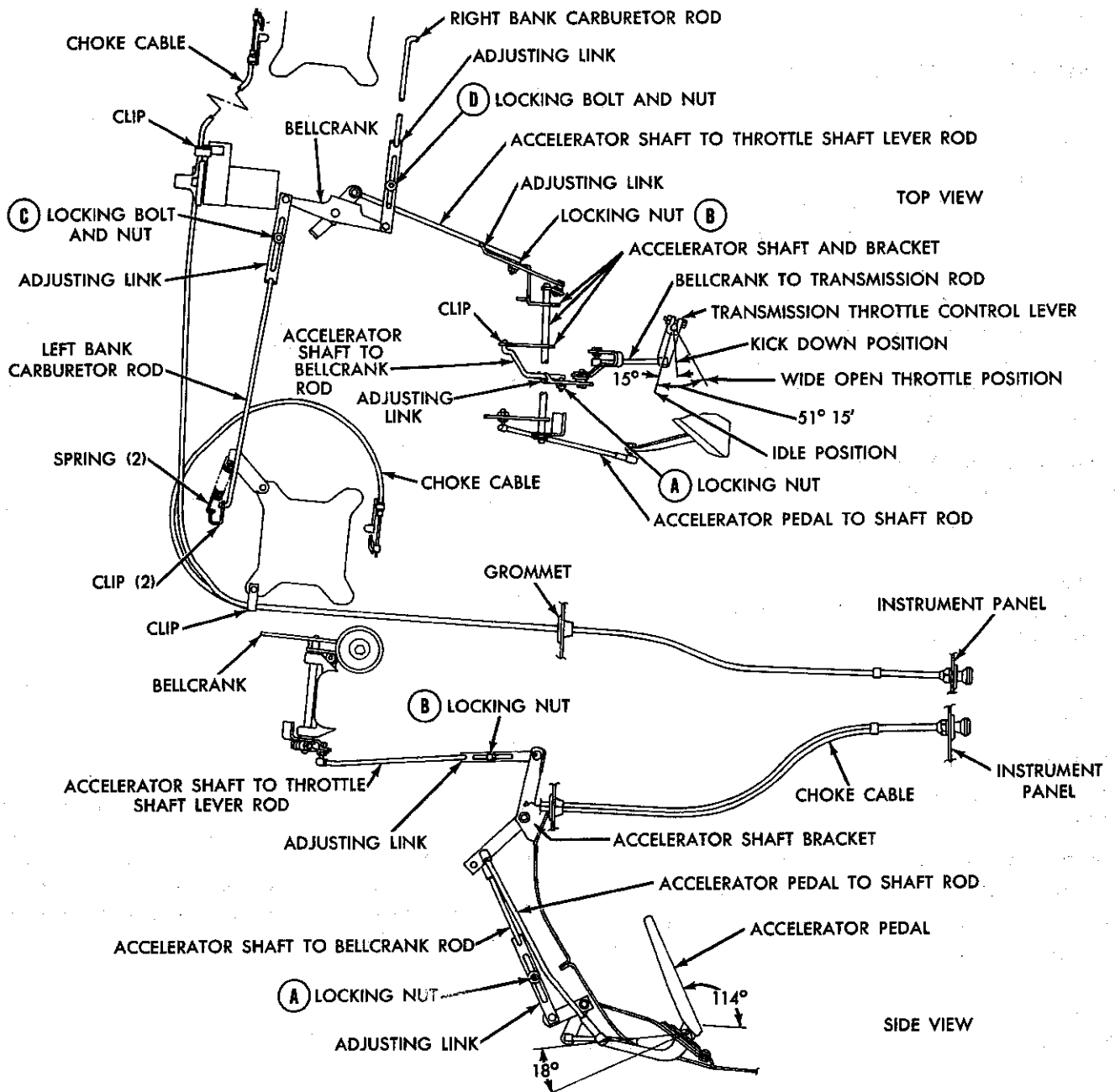

**Fig. 3—Throttle Linkage (Schematic)**



(18) Reconnect the fuel line between the fuel pump and the left hand carburetor.

(19) Reinstall the right and left carburetor air cleaners.

(20) Refill the cooling system to required capacity. (Refer to specifications.)

After the intake manifolds have been installed it is very important that the next procedure of setting the throttle linkage be done in order to obtain peak engine performance.

## 2. SETTING THE THROTTLE LINKAGE

As mentioned previously, setting the throttle linkage is a very important step. Various conditions affecting car performance can be encountered, such as loss of performance, no wide open throttle response, delayed shifting of the transmission, no kickdown, delayed up shifts and etc.

Setting the throttle linkage is divided into three parts, namely: Positioning the accelerator shaft, positioning the accelerator pedal, setting the bellcrank and synchronizing each carburetor. It is very important that the throttle linkage be set in this order.

### Positioning the Accelerator Shaft

To position the accelerator shaft, (if equipped with automatic transmission) refer to Figure 3 then proceed as follows:

(1) Loosen the adjusting nuts "A" and "B" (accelerator shaft to transmission rod and accelerator shaft to throttle shaft lever rod).

(2) Insert a piece of  $\frac{3}{16}$  inch welding rod, 10 inches long into the accelerator shaft bracket and through hole in lever.

(3) Now move the transmission throttle lever forward until it stops. Tighten the locknut "A" securely. This positions the accelerator shaft.

### Positioning the Accelerator Pedal

(1) Unsnap the accelerator pedal from shaft rod.

(2) Turn the threaded end of rod either in or out until a measurement of 114 degrees is obtained between the floor of car and the flat face of the accelerator pedal.

(3) This measurement can be made with a spirit protractor.

(4) After correct measurement has been obtained, reconnect rod. Remove pin from accelerator shaft bracket.

### Setting the Bellcrank

(1) Loosen locking nuts "C" and "D" (left and right bank carburetor rods).

(2) Pivot the ballcrank until a  $\frac{3}{16}$  inch piece of welding rod 3 inches long can be inserted through the bellcrank hole and down into the locating hole in the intake manifold.

(3) Test each carburetor to be sure the choke valves are open; that the fast idle cams are released and that the throttle valves are closed.

(4) Tighten locking nuts "C" and "D" securely. Remove pin from bellcrank.

(5) Push rearward on the accelerator shaft to throttle shaft lever rod adjusting link, until stop is obtained. Tighten locking nut securely.

### Idle Speed and Mixture Adjustment

Connect a tachometer and warm-up the engine to normal operating temperature. Be sure the choke is fully off and that the engine is at curb idle, (transmission in Neutral). Proceed as follows:

(1) Turn the idle mixture screws from 1 to 2 turns open.

(2) Set the idle bypass air screws 2 turns open and adjust the idle speed to 700 rpm. or if equipped with air conditioning, 500 rpm. with the compressor ON.

The idle bypass air screw is located at the front of each carburetor body flange, between the two idle mixture screws. Adjust the idle mixture screws on each carburetor for maximum rpm. Repeat on each carburetor.

Before attaching the rod at each carburetor, check the transmission to throttle linkage adjustments, so that the idle position is not disturbed.

**NOTE: Accurate carburetor synchronization or balance is extremely important and when performed should be rechecked and rebalanced in the outside ambient temperature after a five mile or more road test. This readjustment will prevent rough engine idle performance and possible engine stalling when the vehicle is returned to the owner.**

### Fast Idle Adjustment (On Vehicle)

When making fast idle adjustment on the vehicle, each AFB carburetor should be adjusted individually.

(1) The engine should be at normal operating temperature and have a curb idle speed of 700 rpm. or if equipped with air conditioning, 500 rpm. with the compressor ON.

**14-42 FUEL AND INDUCTION SYSTEM**

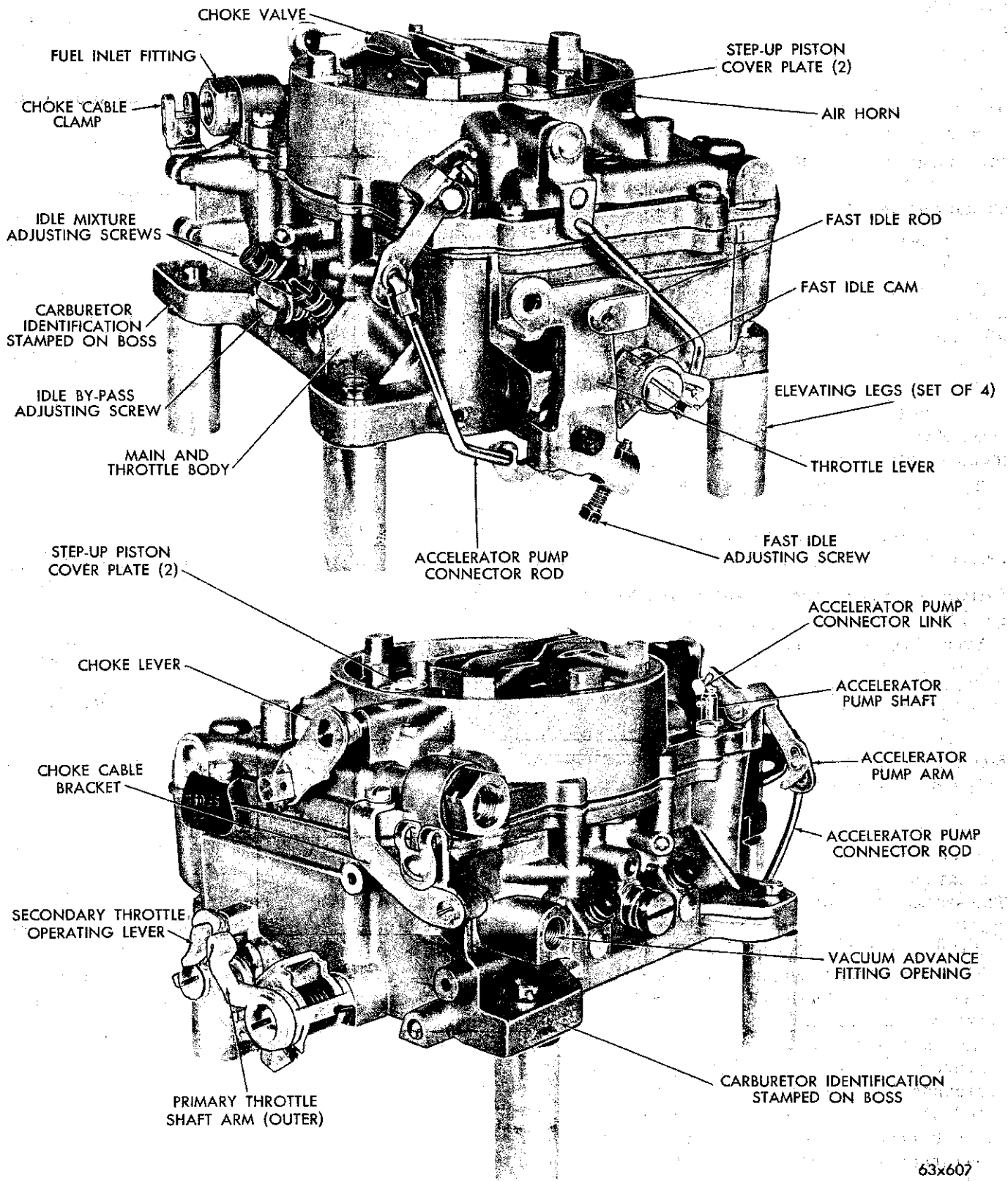

63x607

**Fig. 4—Carburetor Assembly (AFB-35055)**

(2) Turn air conditioning compressor "OFF" (if so equipped) before proceeding with following adjustments.

(3) Remove each air cleaner.

(4) Disconnect each throttle rod at the bellcrank on the intake manifold.

(5) Open the throttle valves of the left carburetor far enough to allow positioning of the fast idle cam to the fast idle index mark. The right carburetor should remain at the curb idle position.

(6) Adjust fast idle screw until a fast idle speed of 1400 rpm. is obtained.

(7) After the desired engine speed has been obtained, open the throttle slightly to allow the fast idle cam to return to the open choke (or off fast idle) position.

(8) Repeat steps 5, 6 and 7 in setting right carburetor fast idle speed as it is very important at the completion of this step (8), that each carburetor has identical fast idle speeds. **There is no specification for engine rpm. with both carburetors simultaneously set at the fast idle position.**

(9) Connect both carburetor throttle rods to the bell crank.

**Carburetor Air Cleaner—Do Not Wash or Oil**

Every 5,000 miles, remove filter element and blow out dirt gently with air hose. Direct air from inside out, and keep nozzle 1 inch away from element to avoid damaging. Clean the metal housing and replace the element. Every 15,000 miles, install a new factory recommended filter element. Service the unit more frequently when driving under severe conditions, such as in dusty areas.

Twin 4-barrel AFB series 3505S carburetors are used on the Chrysler 300K (Fig. 4). These carburetors are basically the same as previous AFB carburetors. The service procedures for disassembly, cleaning, inspection, reassembly and adjustments are different and will be covered in detail.

The carburetor is equipped with a pair of velocity valves, which are controlled by the secondary valve operation. The throttle valves in the secondary half of the carburetor are mechanically connected to the primary valves and open with the primary after an approximate 60 degree lag; and continue to open until both primary and secondary throttle valves reach the wide open position at the same time. As engine speed increases, the forces exerted by the velocity of intake air down through the venturi, permits the off set velocity valves to position themselves according to engine requirements.

The four conventional systems used in this carburetor are two float systems, two low speed systems (primary side only), two high speed systems and the accelerator pump system.

Dirt, dust, water and gummy deposits are some of the main causes for poor carburetor operation. However, proper cleaning and the installation of new parts, where required, will return the carburetor to its originally designed performance.

When overhauling the AFB carburetor, several items of importance should be observed to assure a good job; namely, the carburetor should be carefully disassembled. All parts thoroughly cleaned in a suitable solvent, then inspected for damage or wear. Only air pressure should be used to clear the various orifices and channels. Questionable parts should be replaced with new ones. (When inspecting parts removed from the carburetor, it is at times rather difficult to determine if they are satisfactory for further service. It is recommended, therefore, that in such case, that NEW parts be installed.)

**3. CARBURETOR Disassembly**

(1) Place the carburetor on repair stand C-3400 or elevating legs (4) T109-287S. (These tools are used to protect the throttle valves from damage and to provide a suitable base for working.)

(2) Remove the clip that holds the accelerator pump rod in the center hole in the pump arm, and the hairpin clip that holds the rod in the throttle lever. Remove the rod.

(3) Remove the hairpin clip that attaches the fast idle connector rod to the choke lever. Disengage rod from lever, then swing rod at an arc until it can be disengaged from the fast idle cam.

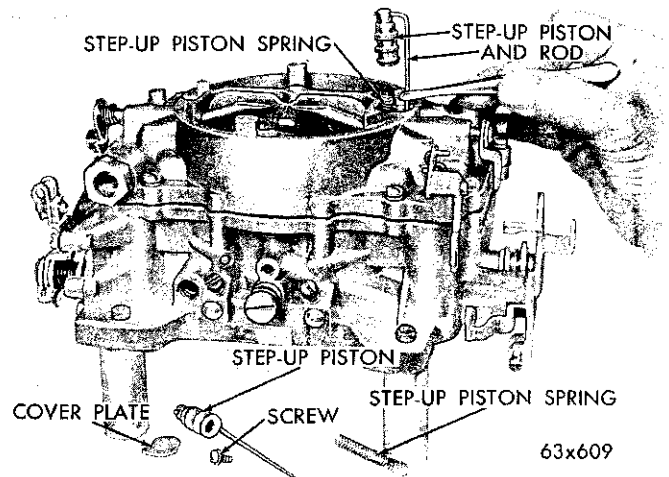

Fig. 5—Removing the Step Up Pistons

(4) Remove the step-up piston cover plate screws and plates. (Hold a finger over plate when removing screws to prevent the piston and metering rods from flying out.) Remove the step-up pistons and metering rods, as shown in Figure 5. Remove the step-up piston springs.

(5) Remove the choke cable bracket, then remove the ten air horn attaching screws (1 screw recessed). Then lift the air horn straight up and away from main body. Be careful not to bend or damage the floats. Remove the pump plunger spring from the pump well.

**Disassembling the Air Horn**

Place the air horn in an inverted position on the bench (mainly to protect the floats), then disassemble as follows:

(1) Remove the float fulcrum pins, then remove each float. (Before removing floats, it is suggested that the float on the pump side be marked so that the floats can be installed in their original locations.)

(2) Remove the two needle valves, after marking the pump side for identification.

(3) Using a wide blade screwdriver, or Tool T109-57, remove the needle valve seats. (Mark the pump side seat for identification.)

(4) Remove the pump arm pivot screw, then disengage the pump link, by removing pump arm. Slide pump plunger out of the air horn, then remove spring seat and compression spring from pump shaft. Discard the air horn to main body gasket.

Place the accelerator pump plunger in a jar of clean gasoline or kerosene to prevent the leather from drying out.

(5) Remove the fuel inlet fitting nut and gasket, then remove filter screen.

**Disassembling the Main Body**

(1) Remove the accelerator pump jet housing screws, then remove jet housing and gasket, as shown in Figure 6. Invert the carburetor and drop out the discharge check needle.

(2) Using Tool T-109-58, remove the main metering jets from the primary and secondary side, as shown in Figure 7. These jets are not interchangeable. (No. 120-159 primary; and No. 120-158 secondary.)

(3) Remove the screws that attach the primary venturi to the main body. (These venturi are not interchangeable side for side, and it is suggested that the pump side venturi be marked for identification). Remove the venturi, as shown in Figure 8. Discard the gaskets. (The pump side venturi is numbered 687. The opposite one, numbered 686.)

(4) Remove the screws that attach the secondary

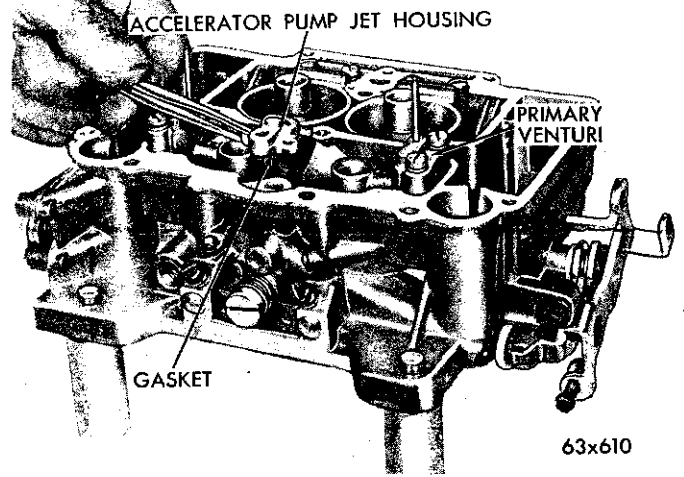

Fig. 6—Removing the Pump Jet Housing

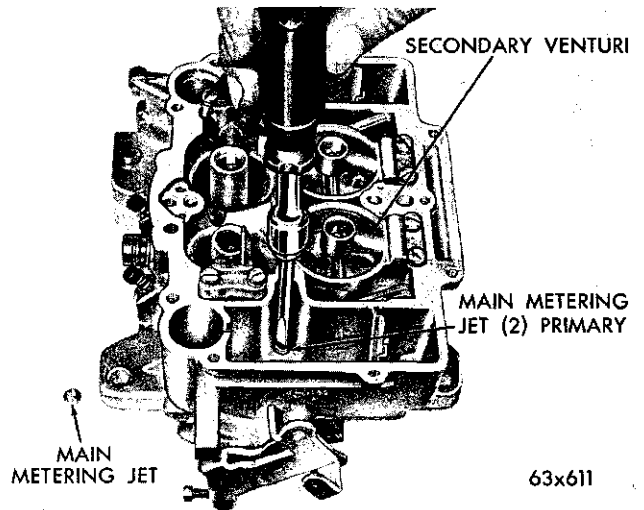

Fig. 7—Removing the Main Metering Jets

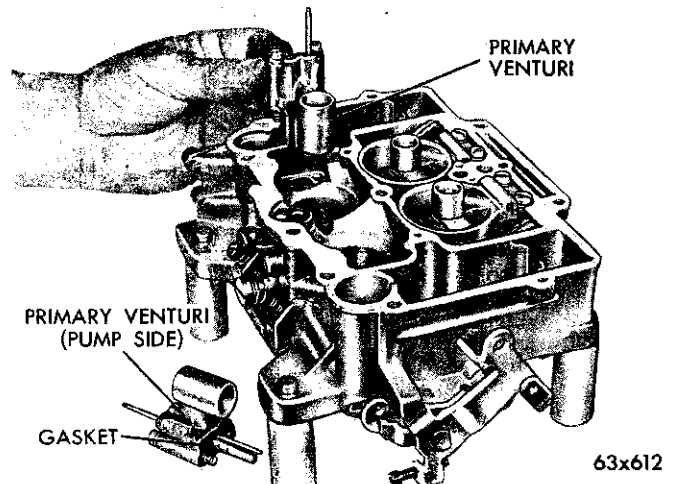

Fig. 8—Removing the Primary Venturi

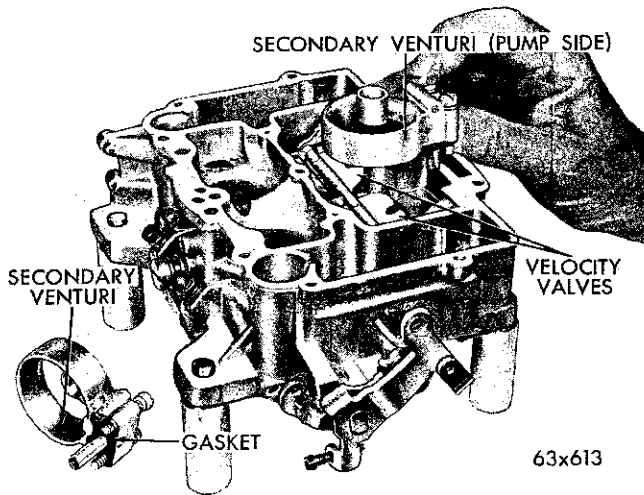

Fig. 9—Removing the Secondary Venturi

venturi to the main body. (These venturi are not interchangeable side for side, and it is suggested that the pump side venturi be marked for identification.) Remove the venturi, as shown in Figure 9. Discard the gaskets. (The pump side venturi is numbered 678. The opposite one, numbered 679.)

(5) Lift out the velocity valves and counterweights, as shown in Figure 10.

(6) Using Tool T109-58, remove the accelerator pump inlet check ball and cage, as shown in Figure 11.

(7) Remove the idle mixture adjusting screws and springs from the throttle body casting.

The carburetor now has been disassembled into two units, namely the air horn and the main throttle body casting. The component parts of each unit have been disassembled as far as necessary for cleaning and inspection.

**Cleaning the Carburetor Parts**

The recommended solvent for gum deposits is de-

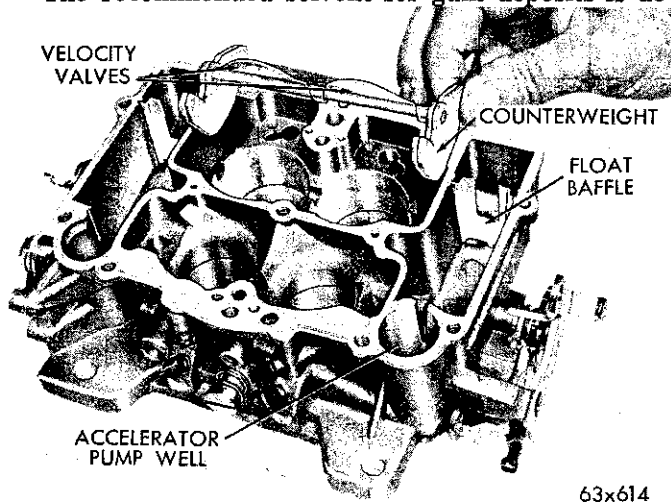

Fig. 10—Removing the Velocity Valves

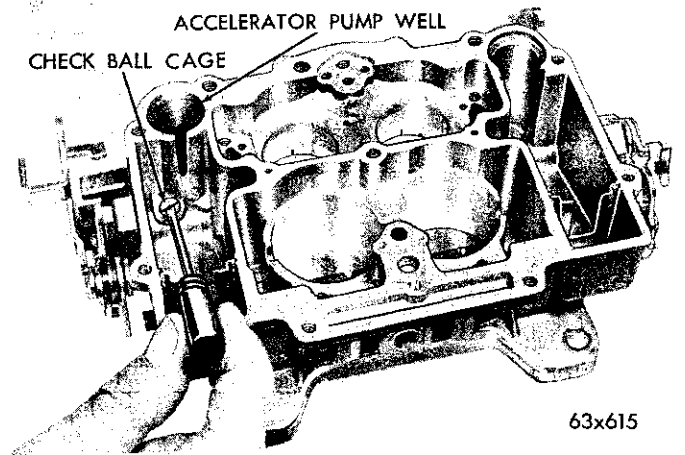

Fig. 11—Removing the Pump Inlet Check Ball Cage

natured alcohol, which is easily obtainable. However, there are other commercial solvents (such as Metalclene) which may be used with satisfactory results.

**IMPORTANT:** If the commercial solvent or cleaner recommends the use of water as a rinse, it should be "HOT". After rinsing, all trace of water must be blown from the various passages with air pressure. It is further advisable to rinse all parts in clean kerosene or gasoline to be certain no trace of moisture remains. Never clean jets with a wire, drill or other mechanical means, because the orifices may become enlarged, making the mixture too rich for proper performance.

**Inspection and Reassembly Throttle Body**

It is usually not advisable to remove the throttle shafts or valves unless the wear or damage is sufficient to affect idle or operation of the carburetor. If

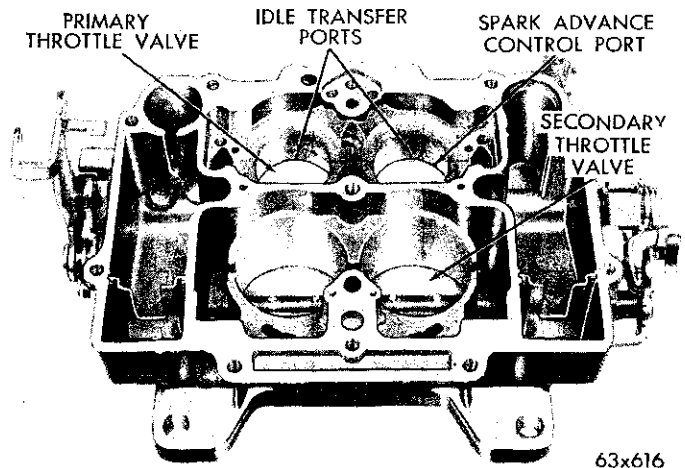

Fig. 12—Parts in Relation to Throttle Valves

such is the case, install a new main and throttle body assembly. However, damaged valves can be replaced providing the instructions for installation are followed closely.

During manufacture, the location of the idle transfer port and the spark advance control ports to the valves is carefully established for one particular assembly (See Fig. 12). Changing the port relationship would affect vehicle operation between the speeds of 15 and 30 miles per hour. If it is necessary to install new valves, proceed as follows:

(1) Remove the screws that hold the throttle valve (or valves) to be replaced to the throttle shaft, then slide valve (or valves) out of the bore.

**CAUTION:** These screws are staked on the opposite side and care should be used so as not to break off in the shaft. Remove staking with a file.

(2) Slide the new valve (or valves) down into the bore and through the slot in the shaft. Install new screws but do not tighten.

(3) Hold the valves in place with the fingers pressing on the high side of valves. Tap the valves lightly with a screwdriver to seat in the throttle bores.

(4) Holding the valves in this position, tighten the screws securely and stake by squeezing with pliers.

(5) Install the two idle mixture adjusting screws and springs in the throttle body. The tapered portion of the screws must be straight and smooth. If the tapered portion is grooved or ridged, new idle mixture screws should be installed to insure having correct idle mixture control. **DO NOT USE A SCREW DRIVER.** The adjustment should be made with the fingers. Turn the screws lightly against their seats then back off one full turn for approximate setting.

(6) Install the velocity valves and counterweights (Refer to Fig. 10).

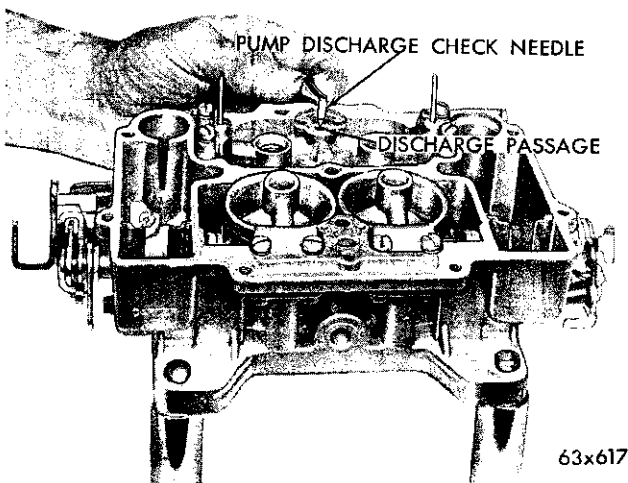

Fig. 13—Installing the Pump Discharge Check Needle

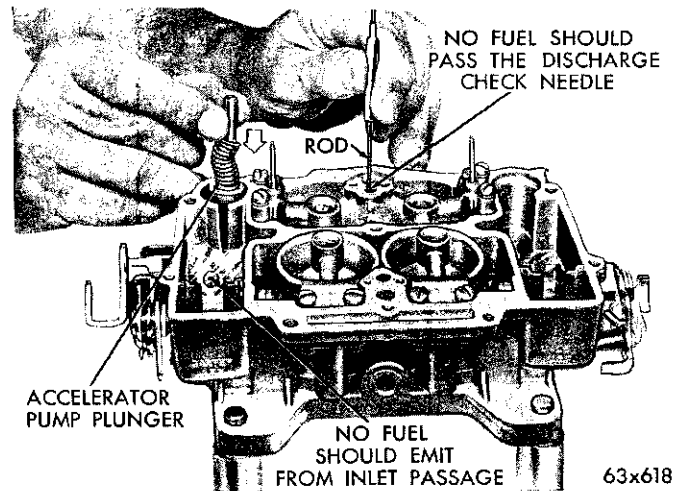

Fig. 14—Testing the Accelerator Pump Check Ball and Discharge Needle

(7) Place new secondary venturi gaskets in position, then install the secondary venturi. (Refer to Fig. 9.) Install screws and tighten securely. Be sure each is located in its original place.

Be sure all the metering holes and vent tubes are clean and clear in both the primary and secondary venturi.

(8) Place new primary venturi gaskets in position, then install the primary venturi. (Refer to Fig. 8.) Install screws and tighten securely. Be sure each is located in its original place.

(9) Install the primary and secondary main metering jets in the main body. Tighten securely, using Tool T109-58. (Refer to Fig. 7.) Tighten securely.

**Accelerator Pump Test**

(1) Pour clean gasoline into the float bowl (pump side) approximately 1/2 inch deep. Remove the pump plunger from the jar of gasoline and flex the leather several times, then slide down into the pump well.

(2) Install the accelerator pump discharge check needle in the discharge passage, as shown in Figure 13. Raise the pump plunger and press lightly on the plunger shaft to expel air from the pump passage.

(3) Using a small clean brass rod, hold the discharge check needle firmly down on its seat. Again raise the plunger and press downward. No fuel should be emitted from the discharge or the intake sage, as shown in Figure 14.

If fuel does emit from the intake passage, remove the intake check ball and cage and reclean. Fuel leakage at the discharge check needle indicates the presence of dirt or a damaged check needle. Clean again and install a new needle. Retest as described above.

If either the intake check ball or discharge check

needle leaks after the above test, attempt to reseal needle or install a new check ball.

### Discharge Check Needle

(1) With the discharge check needle installed, insert a piece of drill rod down on the needle. Lightly tap with a hammer on the end of the drill rod. This will form a new seat for the needle.

(2) Remove and discard old needle and install a new one. Retest as described above.

(3) If the service fix does not correct the condition, a new carburetor will have to be installed.

(4) Install the accelerator pump discharge check needle, jet housing and gasket. Install attaching screws and tighten securely.

(5) Press down on accelerator pump plunger; a clear straight stream should flow from each jet. If the streams are not identical (if either one is diverted or restricted) a new accelerator pump jet housing should be installed.

After test, pour the gasoline from the bowl and remove plunger.

### Assembling the Air Horn

(1) Slide the fuel inlet screen into the fuel line inlet fitting and install in air horn. Tighten securely.

Check to see if the leather on the pump plunger is hard, cracked, or worn. If any sign of wear or deterioration is evident, install a new plunger assembly.

(2) Slide the compression spring over plunger shaft, followed by the spring seat. Now slide the pump assembly into the air horn. Install "S" link to hold in position.

(3) Install a new air horn to main body gasket, then install the float needle valve seats. (Be sure each is returned to its original location.) Tighten securely, using Tool T109-57.

### Synthetic Rubber-Tipped Fuel Inlet Needle

The AFB carburetors are equipped with two synthetic rubber-tipped fuel inlet needles. The needle tip is a rubber-like material which is not affected by gasoline and is stable over a wide range of temperatures. The tip is flexible enough to make a good seal on the needle seat, and to give increased resistance to flooding.

The use of the needles require that care be used when making float adjustments. Avoid any pressure on the floats which might compress the tip of the needles. The tip can be compressed sufficiently to cause a false setting which will affect correct level of the fuel in the bowl.

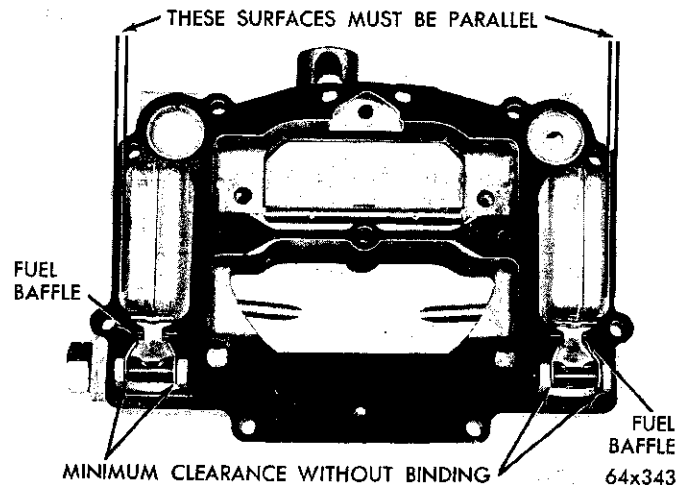

Fig. 15—Measuring the Float Alignment

Install the fuel inlet needles in their respective seats, then install each float and fulcrum pin. (Be sure the marked float is installed on the pump side.)

After the floats have been installed, test the float alignment, level and drop settings as follows:

### Float Alignment Setting

(1) Sight down the side of each float shell to determine if the side of the float is parallel to the outer edge of the air horn casting, as shown in Figure 15.

(2) If the sides of the floats are not in alignment with the edge of the casting, bend the float lever by applying pressure on the end of the float shell with the fingers, while supporting the float lever with the thumb. To avoid damage to the float, apply only enough pressure to bend the float lever.

(3) After aligning the floats, remove as much clearance as possible between the arms of the float lever and the lugs on the air horn. To do this bend

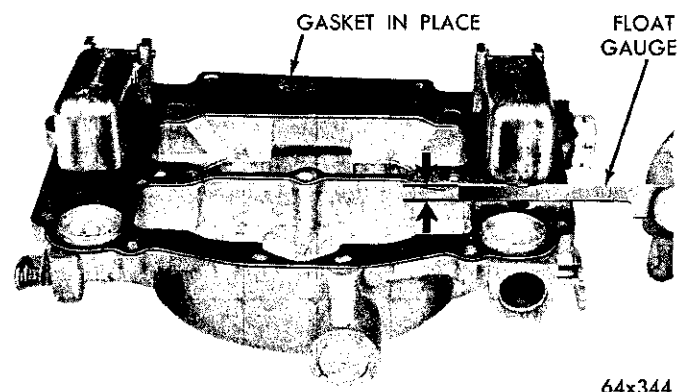

Fig. 16—Measuring the Float Height

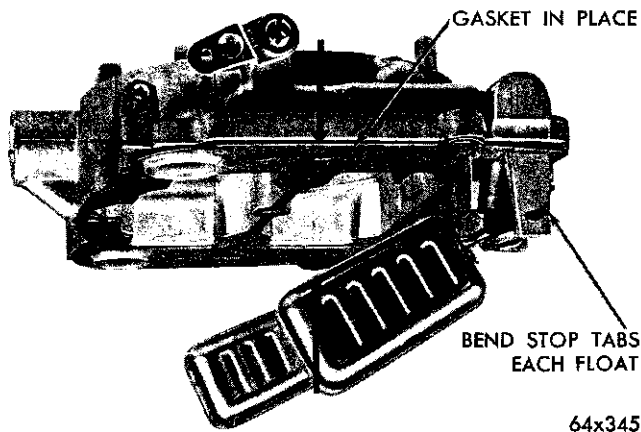

Fig. 17—Measuring the Float Drop

the float lever. The arms of the float lever should be parallel as possible to the inner surfaces of the lugs or the casting.

#### Float Level Setting

(1) With the air horn inverted, the air horn gasket in place and the float needles seated, slide float gauge Tool T109-126 between the top of the float (at outer end) and the air horn gasket, as shown in Figure 16. The float should just touch the gauge.

(2) Check the other float in the same manner. If an adjustment is necessary, bend the float arm, using Tool T109-22, until correct clearance has been obtained. After bending the arm, test the float alignment.

#### Float Drop Setting

(1) Holding the air horn in an upright position, measure the distance from the top of floats (outer end) and the air horn gasket, as shown in Figure 17. This measurement should be  $\frac{1}{2}$  inch. If an adjustment is necessary, bend the stop tabs on the float levers until correct drop setting has been obtained. Bend the tab toward the needle seat to decrease the drop, or away from the float to increase the drop.

After the floats have been checked and adjusted, continue to assemble the carburetor as follows:

(2) Engage the accelerator pump arm with the plunger "S" link and install the pivot screw. Tighten securely.

(3) Place the accelerator pump plunger spring in the pump well, then lower the air horn carefully down on the main body. Be sure the fuel baffles on the air horn slide down in front (bowl side) of the float chamber baffles, or the air horn will not index correctly with the main body. This can cause the floats to "hang up". Also, be sure the leather on the

pump plunger does not curl or wrinkle. Accelerator pump operation will be affected if this precaution is not observed.

(4) Install the air horn attaching screws and tighten securely. Install the choke cable bracket and attaching screws. Tighten securely. (The two long screws should be installed in the holes that are located at the air cleaner mounting surface. The 1 inch screw at the front and the  $1\frac{1}{2}$  inch at the rear.)

(5) Slide the step-up piston springs into the piston wells, followed by the step-up pistons and metering rods. Install the cover plates and attaching screws while holding the step-up pistons down in position. Tighten screws securely. (Refer to Fig. 5.)

(6) Engage the accelerator pump rod with the throttle lever and in the center hole of the pump arm. Install clips to secure.

#### 4. CARBURETOR ADJUSTMENTS

The following adjustments should be made on a reconditioned carburetor, before installation on the vehicle:

##### Accelerator Pump Adjustment

Measure the distance from the top of the air horn to the top of the plunger shaft, using a "T" scale, as shown in Figure 18. This distance should be  $\frac{7}{16}$  inch.

If an adjustment is necessary, bend the pump rod at the lower angle, using Tool T109-213, until the correct travel has been obtained.

##### Secondary Throttle Lever Adjustment

(1) Invert the carburetor and slowly open the primary throttle valves, until it is possible to measure

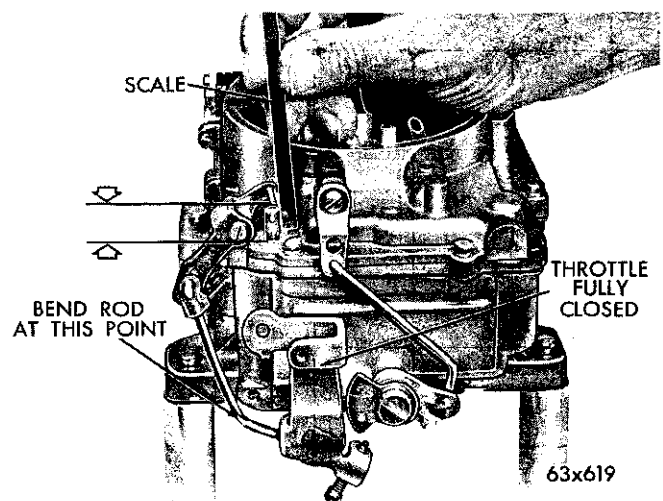

Fig. 18—Measuring the Accelerator Pump Travel



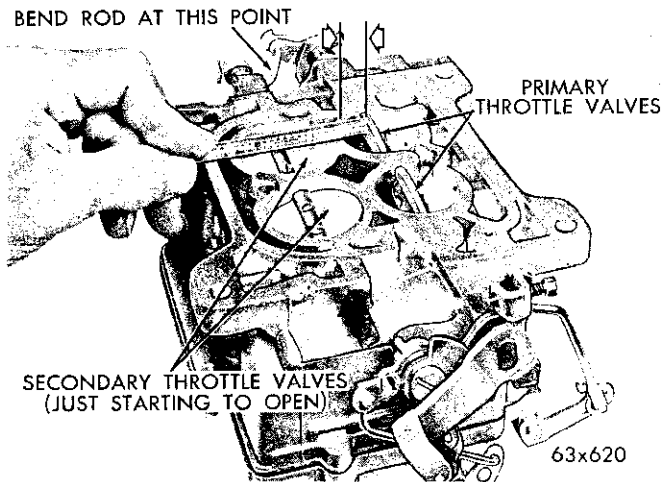

Fig. 19—Measuring the Secondary Throttle Opening

$\frac{29}{64}$  inch between the lower edge of the primary valve and the bore (opposite the idle port), as shown in Figure 19.

(2) At this measurement, the secondary throttle valves should just start to open. The stop lugs on both the primary and secondary throttle levers should contact the bosses on the flange at the same time.

If an adjustment is necessary, bend the secondary throttle operating rod at the angle, using Tool T109-213, until correct adjustment has been obtained. At wide open throttle, the primary throttle valves should be from 6 to 8 degrees past vertical. The secondary throttle valves should be from 6 to 8 degrees before vertical position.

(3) With the primary and secondary valves tightly closed, it should be possible to insert Tool T109-29 (.020 inch) wire gauge between the positive closing shoes on the primary and secondary throttle levers, as shown in Figure 20.

If an adjustment is necessary, bend the shoe on the primary throttle lever, using Tool T109-22, until correct clearance has been obtained.

It is suggested that the carburetor bowls be filled with clean gasoline. This will help prevent dirt that is trapped in the fuel system from being dislodged by the free flow of fuel as the carburetor is primed.

After all adjustments have been made, reinstall the carburetor on the engine, using a new gasket. Tighten mounting stud nuts to 100 inch pounds.

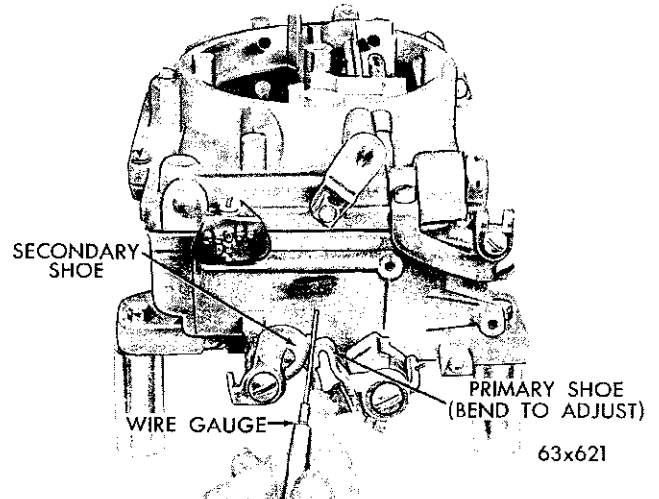

Fig. 20—Measuring the Clearance Between Closing Shoes

**Fast Idle Cam Indexing**

(1) Open the throttle valves to wide open position. Close the choke valve tightly and then close the throttle valves. This will position the fast idle cam to fast idle. The index mark on the cam should split the center of the fast idle adjusting screw, as shown in Figure 21.

(2) If an adjustment is necessary, bend the fast idle connector rod at the angle, using Tool T109-213, until the index mark on the cam indexes the fast idle adjusting screw.

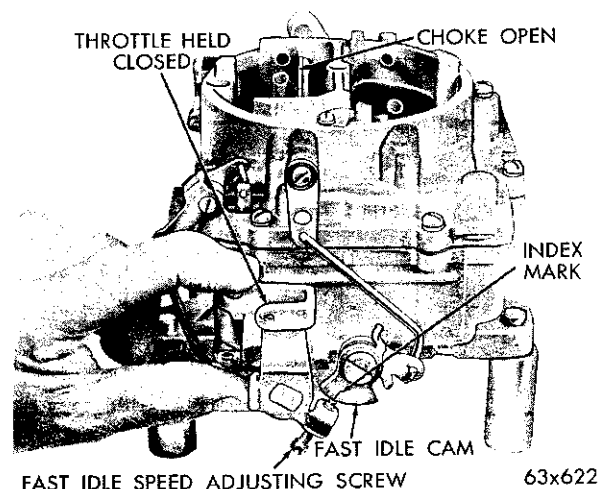

Fig. 21—Fast Idle Cam Indexing

## PART 5

# FUEL PUMP-TANK

### FUEL PUMP

Fuel pump Model M-3672S is used on all Chrysler and Imperial engines. The fuel pump is of the pressed steel type and cannot be disassembled for service. If a pump malfunction occurs, remove the old pump and install a new one.

#### 1. OPERATION—FUEL PUMP

The fuel pump (Fig. 1) is driven by an eccentric cam (cast integral with the camshaft) through the medium of a short push rod.

As the camshaft rotates, the eccentric cam presses against the push rod, forcing the pump rocker arm down. This action lifts the pull rod and diaphragm upwards against the fuel pump main spring, thus creating a vacuum in the valve housing, which opens the inlet valves, forcing fuel into the valve housing chamber. On the return stroke, the main spring forces the diaphragm to the down position which closes the inlet valves and expels the fuel in the valve housing chamber, through the outlet valve to the fuel filter and the carburetor.

It is recommended that the fuel filter be replaced when performing an engine tuneup or at least every 16,000 miles. DO NOT ATTEMPT TO CLEAN.

#### 2. TESTING THE FUEL PUMP (On the Vehicle)

If the fuel pump fails to supply fuel properly to the carburetor, the following tests should be made before removing the fuel pump from the vehicle.

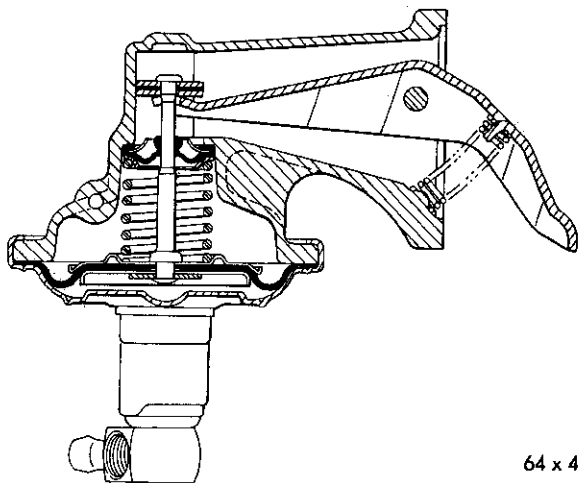

64 x 415

Fig. 1—Fuel Pump Assembly

#### Pressure Test

If leakage is not apparent, test pump for pressure, as follows:

(1) Insert a "T" fitting in the fuel line at the carburetor, as shown in Figure 2.

(2) Connect a 6 inch piece of hose between the "T" fitting and gauge Tool C-3411. (The hose should not exceed 6 inches. A longer hose will collect fuel and the additional weight would be added to the pressure of the pump and result in an inaccurate reading.)

(3) Vent the pump for a few seconds (this relieves any air trapped in the fuel chamber). If this is not done, the pump will not operate at full capacity and a low pressure reading will result.

(4) Connect a tachometer, then start the engine and run at 500 rpm. The reading should be from 3½ to 5 psi. The pressure should remain constant or return to zero very, very slowly when the engine is stopped. An instant drop to zero indicates a leaky outlet valve. If the pressure is too low, a weak main spring or improper assembly of the diaphragm may be the cause. If the pressure is too high, the main spring is too strong.

#### Vacuum Test

The vacuum test should be made with the fuel line disconnected from the carburetor. (This will allow the pump to operate at full capacity, which it must do to prime a dry carburetor.)

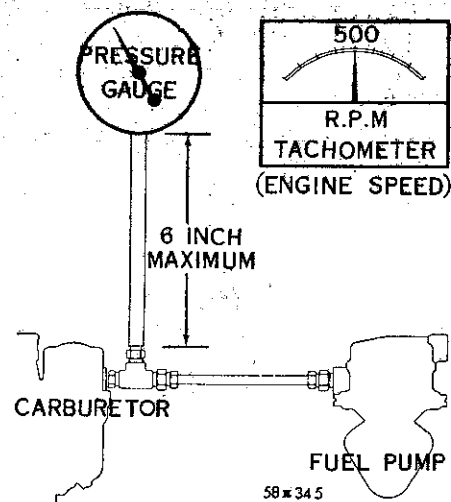

58 x 34 5

Fig. 2—Pressure Testing the Fuel Pump

The vacuum reading should be at least 10" of vacuum at 500 rpm. with the fuel line disconnected at the carburetor.

**Volume Test**

The fuel pump should supply 1 quart of fuel in 1 minute or less at 500 rpm.

**Inlet Valve Test**

To test the inlet valve, connect a vacuum gauge on the inlet fitting while the line is disconnected.

(1) Start the engine or turn over with the starting motor.

(2) There should be a noticeable vacuum present, not alternated by blowback.

(3) If blowback is present, the inlet valves are not seating properly and should be cleaned, or a new valve body installed.

If the fuel pump does not perform to the above test requirements, the fuel pump should be removed from the vehicle and reconditioned as follows:

**FUEL TANK**

The fuel tank on all models except the Town and Country Models is located at the rear of the body, under the trunk compartment floor, as shown in Figure 1. In the Town and Country models, the fuel tank is mounted in the left rear quarter panel beyond the wheel house, as shown in Figure 2.

If the vehicle is to be stored for any appreciable length of time, the gasoline should be drained from the entire system, in order to prevent gum formation. If the vehicle has been undercoated, be sure the fuel tank vent tube (under kickup in floor pan) is open. If this is not done, a collapsed fuel tank will result.

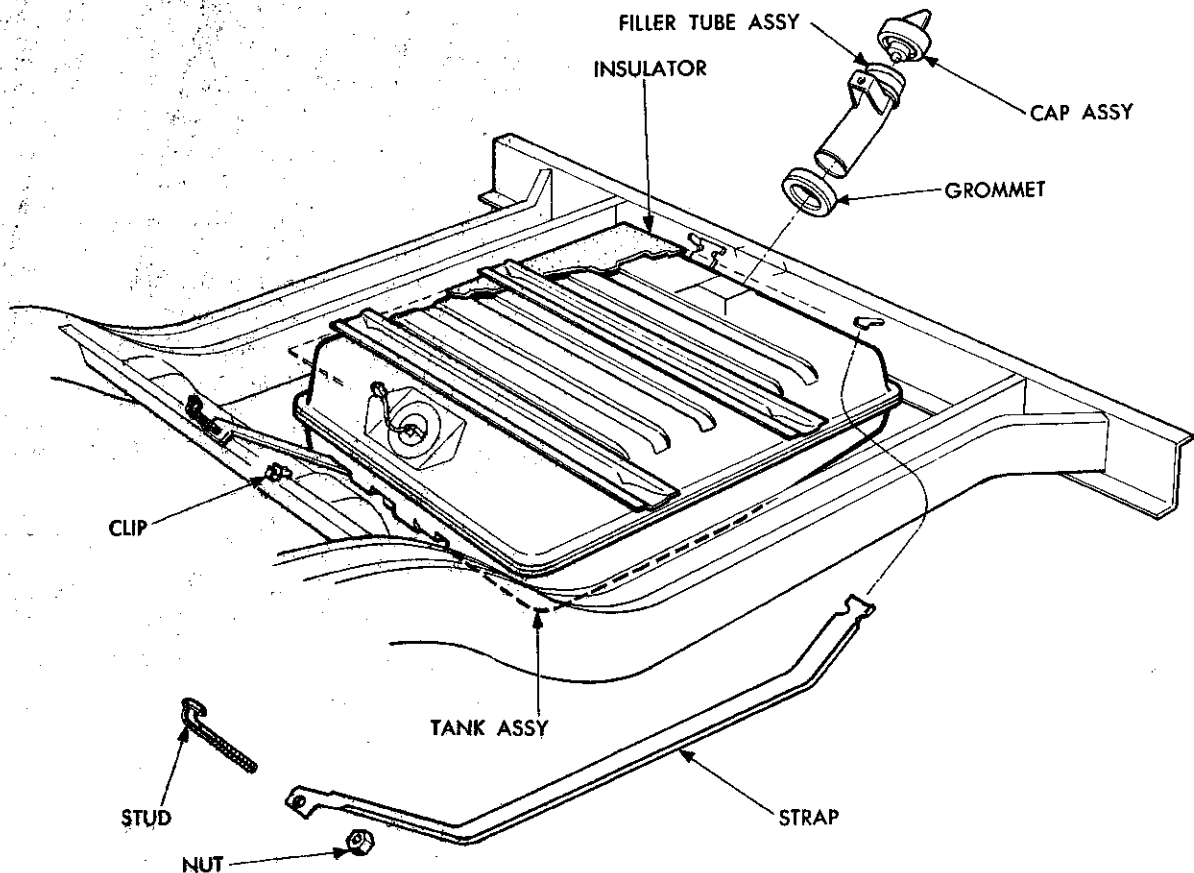

Fig. 1—Fuel Tank Mounting (Chrysler) (Except Town and Country)

The fuel tank on all models except the Town and Country has a 23 gallon capacity. The Town and Country capacity is 21 gallons. The filler tube on the conventional models is accessible through the center of the deck opening lower panel, while the Town and Country fills at the left rear upper quarter panel between the quarter post and the fin. The fuel tank is fitted with a gauge unit, including the suction pipe, as shown in Figure 2. The filter on the end of the suction pipe is replaceable unit and prevents the entry of water and dirt. When installing a tank unit, be sure the filter is pushed on the end of the tube until seated.

**1. REMOVING THE FUEL TANK (Except Town and Country and Imperial)**

**CAUTION:** Be sure the ignition switch is turned off before disconnecting or connecting the gauge wire.

**Removal**

- (1) Drain the tank into a safety can, then disconnect the fuel line and the wire lead to the gauge unit.
- (2) Disconnect the vent tube at the nose connection at the leading edge of the tank.

- (3) Remove the nuts that hold the ends of the fuel tank hold down straps to the frame. Lower the front end of the tank far enough to disengage the filler tube from the rear panel and slide out from under the vehicle.

- (4) Remove the tank gauge unit, using spanner wrench Tool C-3582 (Fig. 3). Check the rubber grommet around the filler tube. If cracked or deteriorated, install a new grommet at reassembly.

**Installation**

Before installing the tank gauge unit, check the condition of the filter on the end of suction tube. If the filter is plugged, plastic will not corrode, install a new filter.

- (1) Position the fuel tank gauge unit in the tank, using a new gasket. Tighten securely, using Tool C-3582.
- (2) Slide the fuel tank under the vehicle. Raise the tank far enough to engage the filler spout with the opening in the rear panel, and the locator embossments on the floor pan.
- (3) Push the tank toward the rear to fully engage the filler spout in the opening.

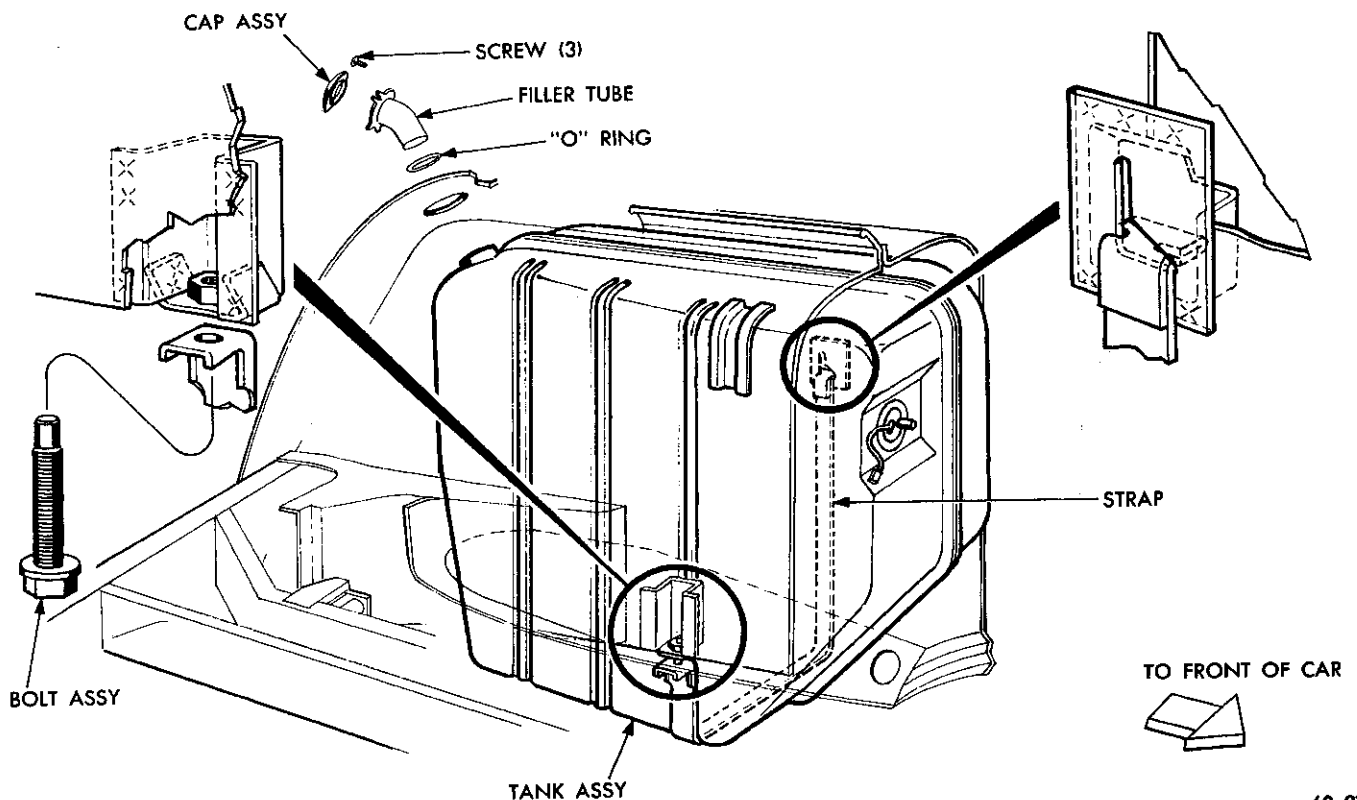

Fig. 2.—Fuel Tank Mounting (Town and Country)

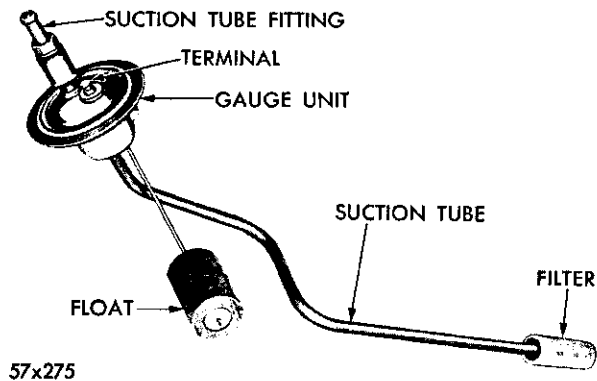

Fig. 3—Fuel Gauge Tank Unit

(4) Hold the fuel tank in this position, and place the hold down straps in position, feeding the attaching studs through holes in the end of the straps. Install the nuts but do not tighten.

(5) Guide the button head of the studs into the slots in the frame and down into position. Tighten the hold down strap attaching nuts securely.

(6) Connect the lead wire to the tank gauge unit and reconnect the fuel line.

(7) Refill the tank and check for leaks.

## 2. FUEL TANK AND FILLER TUBE (Imperial)

### Removal

**CAUTION:** Disconnect the battery cable at the battery post before disconnecting or connecting the fuel gauge wire.

(1) Drain the tank, then disconnect the fuel line and the lead wire to the fuel gauge unit.

(2) Remove the screw that attaches the filler tube bracket to the trunk panel.

(3) Push the tube into the tank far enough for the tube bracket to clear the trunk panel. Push the tube downward slightly so that the mounting bracket clears the opening in the panel. Pull the tube out of the tank, using a suitable tool.

(4) Loosen the nuts that hold the ends of the fuel tank tie down straps until the button heads can be disengaged from the floor pan brackets. Disengage the studs from the brackets, then lower the tank to the floor.

(5) Remove the tube seal and inspect. If the seal is cracked or deteriorated, install a new seal at reassembly.

(6) Remove the gauge tank unit, using spanner wrench Tool C-3582. Discard the gasket.

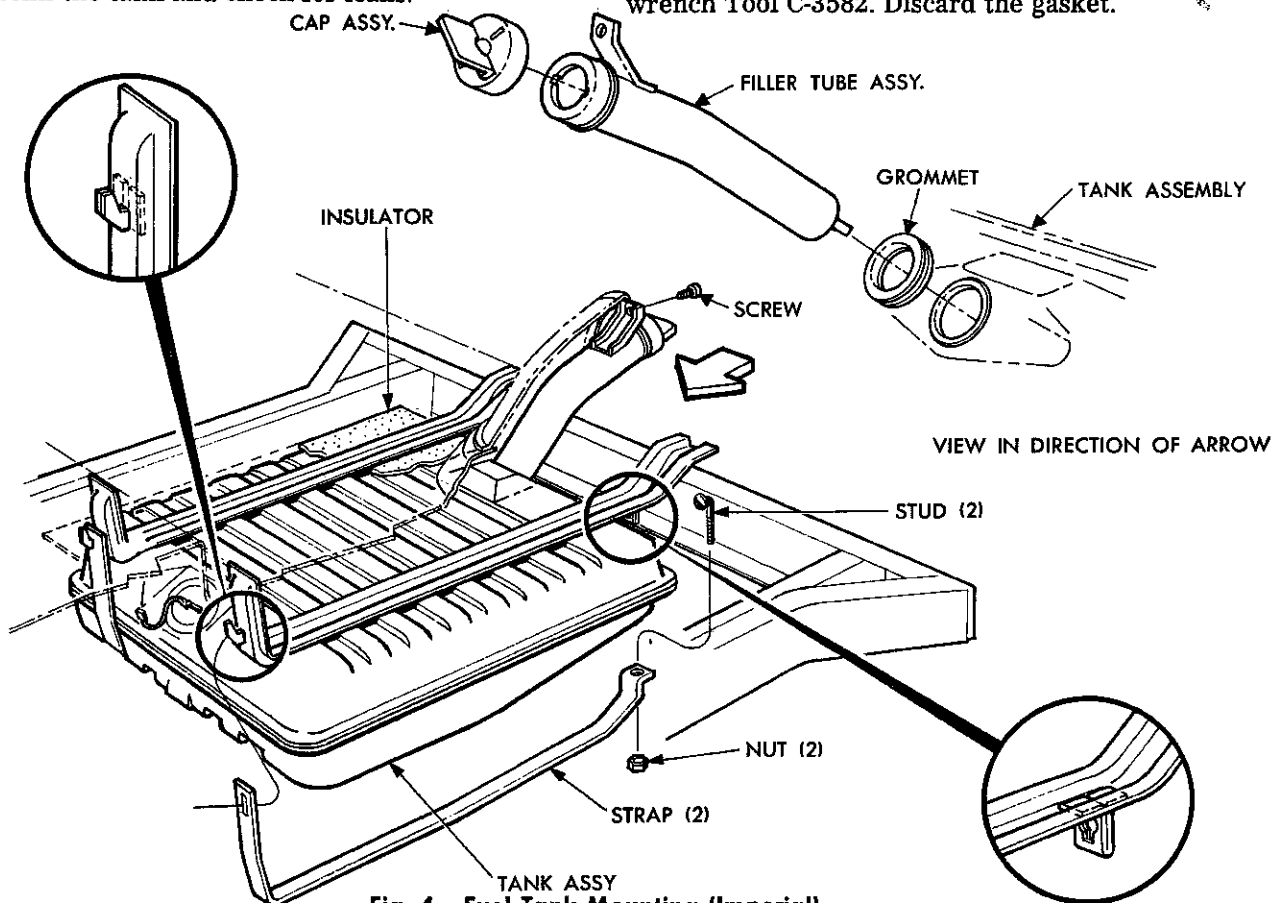

Fig. 4—Fuel Tank Mounting (Imperial)

**Installation**

**NOTE:** When installing a new tube seal, be sure the diameter of the seal lip is placed in the tank opening. Do not use any lubricant on the seal at the tank contact surface.

**NOTE:** Before installing the tank gauge unit, inspect the condition of the filter on the end of the suction tube. If the filter is corroded, install a new filter unit.

(1) Position the fuel tank gauge unit in the tank, using a new gasket. Using Tool C-3582, tighten the unit securely.

(2) Install a new filler tube seal in the tank opening, as described above. Lightly coat the inner side of the seal with lubricate.

(3) Slide the tank up into position, against the locator embossments on the floor pan. Install the button head studs in the slots in the floor pan brackets. Snug down the nuts, but do not tighten.

(4) Check and be sure the fuel tank is in the correct position, then tighten the nuts securely.

(5) Connect the fuel line to the tank fitting and the lead wire to the gauge unit.

(6) Insert the filler tube through the trunk panel and insert into the seal. Push the tube into the tank far enough for the tube mounting bracket to clear the trunk panel opening. Slightly pull the tube out of the tank until the bracket aligns with the mounting screw hole. Install the screw and tighten securely.

(7) Refill the tank and inspect for leaks.

### 3. FUEL TANK (Town and Country) (Fig. 2)

**Removal**

**CAUTION:** Be sure the Ignition Switch is turned OFF before disconnecting or connecting the gauge wire.

(1) Drain the tank, and disconnect the fuel line and the lead to the gauge unit under the rear fender, behind the wheel house.

(2) Remove the screws that attach the stone shield to the lower edge of the wheel house at the rear. Remove the shield.

(3) Remove the button plug at the rear of wheel house (front of gauge unit).

(4) Remove the bolt and washer that attaches the tank hold down strap to the lower support.

(5) Remove the filler cap and the filler tube sleeve attaching screws. Using a suitable tool, or Tool C-3584, pull out the filler tube. Slide the sleeve out of the body opening. Remove the gasket from sleeve and "O" ring from the filler tube.

(6) Slide the tank down and out from under the quarter panel. Reach up under the quarter panel and disengage the hold down strap from the bracket. If strap is to be replaced, refer to Figure 2.

(7) Loosen the tank gauge unit, using a spanner wrench Tool C-3582. Slide the unit up and out of the tank.

Check the condition of the rubber "O" ring. If cracked or deteriorated, install a new "O" ring at reassembly.

**Installation**

Before installing the tank gauge unit, check the condition of the filter on the end of suction tube. If the filter is corroded, install a new filter.

(1) Position the fuel tank gauge unit in tank, using a new gasket. Tighten securely, using Tool C-3582.

(2) Slide the hold down strap under this quarter panel, inserting the end of strap into slot. Allow the strap to hang.

(3) Install a new "O" ring in the neck of the tank.

(4) Slide the tank up under the quarter panel with the gauge unit facing front of the vehicle. Push the tank up into position. Make sure the filler neck is aligned with the opening in top of the quarter panel. Attach with the strap and bolt. Do not tighten.

(5) Place a new gasket over the filler tube and down against the flange. Insert the filler tube down into neck of tank. Drive the tube into "O" ring until the dimples in the tube contact the seal retainer. Be sure the anchor tab on the tube is aligned with a screw hole. Install the screws and tighten securely.

(6) Tighten the fuel tank hold down strap bolt securely.

(7) Install the stone shield. Connect fuel line and lead to gauge unit. Reinstall the button plugs. Refill the tank and check for leaks.

For testing the fuel gauge, refer to the "Electrical" Group 8 "Gauges."

## PART 6

### SERVICE DIAGNOSIS

Condition	Possible Cause	Correction
<b>Poor Idling</b>	(a) Idle air bleed carbonized or of incorrect size.	(a) Disassemble the carburetor. Then, use compressed air to clear idle bleed after soaking it in a suitable solvent.
	(b) Idle discharged holes plugged or gummed.	(b) Disassemble the carburetor. Then, use compressed air to clear idle discharge holes after soaking the main and throttle bodies in a suitable solvent.
	(c) Throttle body carbonized or worn throttle shaft.	(c) Disassemble the carburetor. Inspect the throttle valve shaft for wear. If excessive wear is apparent, replace the throttle body assembly.
	(d) Damaged or worn idle mixture needle.	(d) Replace the worn or damaged idle needle. Adjust the air mixture.
	(e) Low grade fuel or incorrect float level.	(e) Test the fuel level in the carburetor. Adjust as necessary to obtain the correct float level.
	(f) Loose main body to throttle body screws.	(f) Tighten the main body to throttle body screws securely to prevent air leaks and cracked housings.
<b>Poor acceleration</b>	(a) Accelerator pump by-pass seat corroded or bad.	(a) Disassemble the carburetor. Clean and inspect accelerator pump by-pass jet. Replace by-pass if it is in questionable condition.
	(b) Accelerator pump piston (or plunger) leather too hard, worn, or loose on stem.	(b) Disassemble the carburetor. Replace accelerator pump assembly if leather is hard, cracked or worn. Test follow-up spring for compression.
	(c) Faulty accelerator pump discharge ball.	(c) Disassemble the carburetor. Use compressed air to clear the discharge nozzle and channels after soaking the main body in a suitable solvent. Test the fuel pump capacity.
	(d) Faulty accelerator pump inlet check ball.	(d) Disassemble the carburetor. Inspect the accelerator pump inlet check ball for poor seat or release. If part is faulty, replace.
	(e) Incorrect fuel or float level.	(e) Test the fuel or float level in the carburetor. Adjust as necessary to obtain the correct float level.
	(f) Worn or corroded needle valve and seat.	(f) Clean and inspect the needle valve and seat. If found to be in questionable condition, replace assembly. Then, test fuel pump pressure. Refer to Specifications for correct fuel pump pressure.
	(g) Worn accelerator pump and throttle linkage.	(g) Disassemble the Carburetor. Replace the worn accelerator pump and throttle linkage and measure for the correct position.
	(h) Automatic choke not operating properly.	(h) Test adjustment and operation of automatic choke. If necessary, replace the choke.
<b>Carburetor floods or leaks</b>	(a) Cracked body.	(a) Disassemble the carburetor. Replace the cracked body. Make sure main to throttle body screws are tight.
	(b) Faulty body gasket.	(b) Disassemble the carburetor. Replace the faulty gaskets and test for leakage. Be sure the screws are tightened securely.

**SERVICE DIAGNOSIS—(Continued)**

Condition	Possible Cause	Correction
	(c) High float level.	(c) Test the fuel level in the carburetor. Make the necessary adjustment to obtain float level.
	(d) Excessive fuel pump pressure.	(d) Clean and inspect the needle valve and seat. If found to be in a questionable condition, replace the complete assembly and test the fuel pump pressure. Refer to Specifications for correct fuel pump pressure. (e) Test the fuel pump pressure. If the pressure is in excess of recommended pressure (refer to Specifications), replace fuel pump.
<b>Poor performance— Mixture too rich</b>	(a) Restricted air cleaner.	(a) Remove and clean the air cleaner.
	(b) Leaking float.	(b) Disassemble the carburetor. Replace leaking float. Test the float level and correct as necessary to the proper level.
	(c) High float level.	(c) Adjust the float level as necessary to secure the proper level.
	(d) Excessive fuel pump pressure.	(d) Test the fuel pump pressure. Refer to Specifications for recommended pressure. If pressure is in excess of recommended pressure, replace the fuel pump assembly.
	(e) Worn metering jet.	(e) Disassemble the carburetor. Replace the worn metering jet, using a new jet of the correct size and type.

**POOR COLD ENGINE STARTING**

<b>Incorrect Procedure</b>	(a) Throttle must be opened to free choke system. Best position for all temperatures and all conditions is $\frac{1}{3}$ open.	(a) Instruct owner.
<b>Choke Valve Fails to Close</b>	(a) Choke thermostat adjustment leaner than specified.	(a) Adjust.
	(b) Choke thermostat corroded such that it has cracked and distorted lean.	(b) Replace assembly.
	(c) Choke linkage, shaft or related parts corroded, bent or dirty such that the system is not entirely free to move from the open to the closed position.	(c) Repair, clean or replace.
	(d) Choke valve improperly seated.	(d) Reseat valve.
	(e) Air cleaner interferes with choke shaft or linkage.	(e) Rotate cleaner to correct position.



**SERVICE DIAGNOSIS— (Continued)**

Condition	Possible Cause	Correction
	(f) Air cleaner gasket interferes with choke valve or linkage.	(f) Reinstall gasket properly.
<b>Low Engine Output (10°F or lower)</b>	(a) Engine lubricating oil of incorrect viscosity. (b) Valve Lash incorrect. (c) Choke thermostat adjustment incorrect, rich.	(a) Recommend 5W-20. (b) Readjust. (c) Adjust to correct setting.
<b>ENGINE RUNS LEAN, FIRST HALF MILE</b>		
<b>Choke Lean</b>	(a) Check items under (Poor Starting). (b) Diaphragm adjustment lean.	(a) See "Choke Valve Fails to Close". (b) Readjust to specification.
<b>ENGINE RUNS LEAN AFTER HALF MILE</b>		
<b>Engine Heat Insufficient</b>	(a) Heat valve stuck open. (b) Heat valve thermostat distorted. (c) Heat valve failed within exhaust. See engine section for proper diagnosis. (d) Water temperature sub-normal.	(a) Free with solvent. (b) Replace thermostat. (c) Replace heat valve. (d) Test the thermostat.
<b>Carburetor Mixtures Lean</b>	(a) Air leak bypassing the carburetor. (b) Carburetor has economy metering system.	(a) Repair. (b) Inform customer.
<b>ENGINE RUNS EXCESSIVELY RICH AFTER COLD START</b>		
<b>Choke System Rich</b>	(a) Choke thermostat adjustment richer than specified. (b) Choke thermostat distorted rich by overheating. (c) Choke vacuum diaphragm inoperative or misadjusted. (d) Choke Vacuum passage blocked or leaking.	(a) Correct. (b) Replace, since this problem can be corrected by use of proper choke assembly. (c) Correct or replace. (d) Correct.
<b>Carburetor Rich</b>	(a) Incorrect gasket or gasket installation between carburetor and intake manifold.	(a) Replace or correct.

**14-58      DIAGNOSIS—FUEL SYSTEM**

---

<b>Condition</b>	<b>Possible Cause</b>	<b>Correction</b>
<b>EXCESSIVE STALLS AFTER COLD START</b>		
<b>Choke System Lean</b>	(a) Check items under "Poor Starting-Choke Valve Fails to Close".	(a) Refer to page 56 for correction.
	(b) Choke vacuum diaphragm adjustment lean.	(b) Adjust to Specification.
<b>Engine Output Low</b>	(a) Fast idle speed low.	(a) Adjust to specification.
	(b) Fast idle cam position adjustment incorrect.	(b) Adjust to specification.
	(c) Engine lubrication oil of incorrect viscosity.	(c) Recommend 5W-20.
<b>Carburetor Lean</b>	(a) Curb idle set very lean.	(a) Adjust.
	(b) Air leak bypassing the carburetor.	(b) Repair.

---