

GROUP 23
BODY AND SHEET METAL
CONTENTS

PART 1—BODY MAINTENANCE

	Page		Page
Cleaning Interior Upholstery.....	5	Rear Window (Convertible Coupe).....	6
Paint Finish Care (All Models).....	5	Care and Cleaning of the Top.....	6

PART 2—BODY ADJUSTMENTS

Aligning the Hood.....	7	Vent Wing Frame and Door Glass Adjustment.....	12
Aligning Doors (All Models).....	8	Front Door Vent Wing and Door Glass Adjustment (Hardtop Models) Chrysler.....	13
To Raise or Lower Door (Front Doors).....	9	Rear Door Glass Adjustment (Hardtop) Imperial.....	13
Moving the Door Forward or Back (Front Door).....	9	Rear Door Glass Adjustment (Hardtop) Chrysler.....	14
Fitting the Front Door Flush with Adjacent Panels.....	9	Quarter Glass Adjustment (Imperial).....	14
Final Door Striker Plate Adjustment.....	9	Quarter Glass Adjustment (Chrysler).....	15
Rear Door Adjustments.....	10	Hood.....	15
Deck Lid Alignment.....	10	Hood Hinge.....	15
Centering Deck Lid in Opening.....	10		

PART 3—BODY SEALING

Weatherstrip Adhesive.....	16	Housing—Fuel Filler.....	21
Windshield Rubber Cement.....	16	Rear Quarter Panel.....	21
General Seam Sealing Material.....	16	Rear Window.....	22
Gasoline Resistant Sealer.....	16	Deck Lid Lock Cylinder and Bezel.....	22
Water and Dust Leakage Areas.....	16	Roof.....	22
Door Openings.....	19	Exterior Moulding Attachment.....	23
Luggage Compartment Sealing.....	20	Floor Pan Leakage.....	23
Leakage at Deck Lid.....	21		

PART 4—MINOR BODY SERVICING

Grille (Imperial Models).....	24	Door Inside Hardware and Trim (Manual Door Locks).....	30
Grille (Chrysler Models).....	24	Door Lock and Remote Control Assemblies.....	31
Deflector (Imperial Models).....	24	Outside Door Handle and Key Cylinder.....	33
Deflector (Chrysler Models).....	24	Lock Cylinder.....	33
Fender.....	24	Front and Rear Door Window Regulator.....	34
Radiator Core Support.....	25	Rear Deck Lid, Hinges and Locks—Removal, Installation Alignment.....	35
Door and Quarter Panel Trim Replacement.....	25	Rear Deck Lid (Convertible).....	35
Door and Quarter Panel Trim Panels Removal.....	25	Deck Lid.....	36
Electric Window Regulator Switch Removal.....	25	Deck Lid Hinges.....	37
Door Opening Weatherseal.....	26	Windshield Glass—(All Models).....	37
Headlining.....	26	Convertible Windshield Glass.....	39
Custom Positioned Six-Way Manual Front Seat Adjustment.....	28	Rear Window Glass.....	40
Front Seat.....	28	Front Door Vent Wing.....	40
Rear Seat.....	29	Front Door Glass.....	41
Rear Seat Back.....	29	Front Door Glass (Four Door Sedan) Chrysler.....	43
Exterior Mouldings.....	29	Rear Door Glass (Four Door Hardtop and Town and Country).....	43
Front Door.....	29	Rear Door Glass (Four Door Sedan).....	44
Rear Door (All Models).....	30	Quarter Glass (Convertible and Hardtop).....	44
Door Hinges (All Models).....	30		

CONTENTS—(Continued)**PART 5—MAJOR BODY SERVICING**

	Page		Page
Replacement of Body Panels Sub-Assemblies (All Models)	46	Removing old Finish	47
Paint Refinishing	47	Refinishing	48
Preparation	47	Application	48

PART 6—CONVERTIBLE MAINTENANCE

Body Alignment—Imperial Only	49	Front Top Bow Adjustment	53
Operating the Convertible Coupe Top	49	Roof Side Rail Weatherstrip Adjustment	54
Top Adjustments	49	Rear Bow Tension Cables	54
Top Headers	50	Correcting Wrinkles in Backlight	54
Top Header Adjustment	50	Correcting Top Well Water Leak	55
Correcting Top Header Water Leaks	51	Servicing the Top Folding Mechanism	55
Vent Frame Leak at Top Edge	51	Fluid Level in Reservoir	55
Roof Side Rail Alignment	51	Top Will Not Raise or Lower	55
Front Hinge Adjustment	52	Testing the Top Control Switch	56
Rear Hinge Adjustment	52	Testing Wires between Control Switch and Pump Motor	56
Main Control Prop Link Bracket Adjustment	53	Rear Window (Convertible Coupe)	56
Top Shifts to One Side	53	Care and Cleaning of Top	56
Power Guide Link Adjustment	53		

PART 7—TOWN AND COUNTRY

Tail Gate	57	Tail Gate Glass	59
Tail Gate Glass	57	Tail Gate Weatherstrip	59
Tail Gate Glass Run Channel	58	Tail Gate Sealing	59
Folding Third Seat	58	Tail Gate Glass Run Channel Leakage	60
Quarter Glass	58	Tail Lamps	60
Power Windows (Vent Wing, Door, Quarter Glass and Tail Gate)	59		

PART 8—SERVICE DIAGNOSIS

Manual Door Locks and Linkage	61	Convertible Coupe Top	64
Vacuum Door Locks	62		

BODY AND SHEET METAL

All Chrysler models, except Imperial, feature a "Unibody" type construction (Fig. 1) in which the body shell and the underbody (frame) are welded together into one unit.

The Imperial Models use a conventional type body in which the body is bolted to the frame (Fig. 2).

To achieve greater terminal rigidity and improve overall strength of the body-shell on the "Unibody" construction, two heavy-duty crossmembers, one under the rear seat area and the other at the extreme rear end of the body are welded to the box side rails extending from under the rear seat over the body "kick-up" to the rear of the body. These box-section

members with extra reinforcements also attach the rear springs and axle assembly (Fig. 3).

The radiator yoke, fender side shields and cowl panels are attached to the body to add structural strength to the fore-structure and the body assembly.

An integral fore-structure assembly extending forward of the front passenger compartment is bolted to the "Unibody" with ten body bolts, eight of these lie in a fore-and-aft position and two in a transverse position.

The fore-structure, with box-section side rails and "Y" section reinforcements at the front-end, has three crossmembers. The first crossmember supports

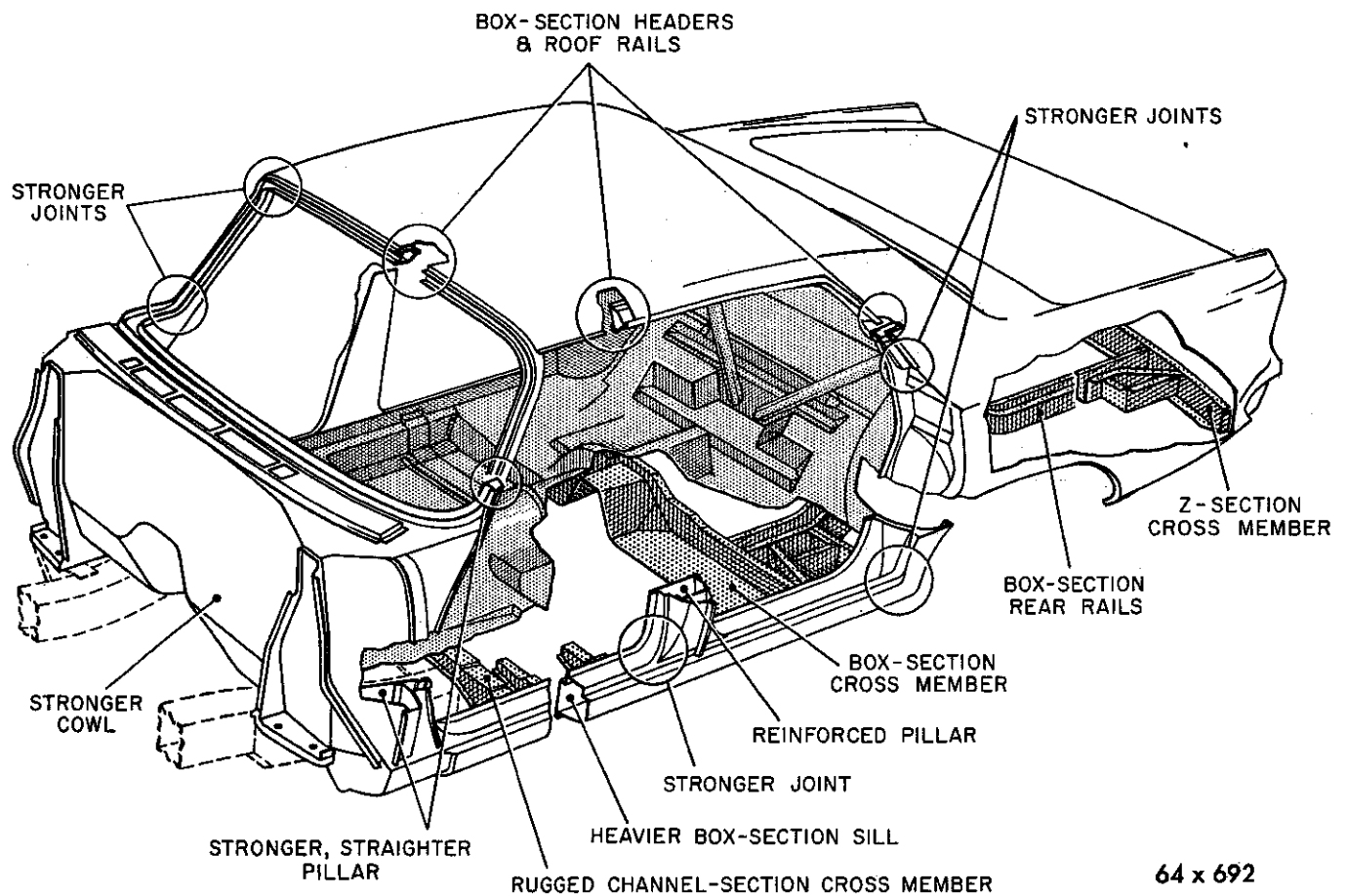

64 x 692

Fig. 1—Basic Body Construction (Chrysler)

23-4 BODY AND SHEET METAL

the diagonal struts for the front suspension control arms, the second crossmember supports the front engine mounts, and the number three crossmember supports the engine and transmission at the rear engine mount.

The heavy roof bows in the body assure greater strength to the roof panel. The front door hinge pillar is one continuous piece from roof rail to the body sill. Sheet metal seams overlap for improved sealing. Metal cages welded to the outside of the cowl side panels enclose the retaining nuts for attaching fenders and hood hinge supports. Inner hinge reinforcements have been added to the doors to keep the doors aligned and maintain proper door adjustment.

The hood construction incorporates heavy hinge supports to eliminate hood flutter. The "Unibody"

is subjected to a 7 step corrosion and rust-proofing immersion and spraying operation. Each immersion covers the entire underbody internally and externally extending up to body and door sides.

On the Imperial models (Fig. 2), heavier section center pillars, box section and roof rails, are used to improve the overall strength of the upper body structure. The body diagonal braces are welded to the underside of the floor pan to minimize flexing.

The floor-pan design includes metal-to-metal welded lap-joints to eliminate dust and water leaks. "U" braces behind the rear seats and quarter panel are welded to the floor-pan to increase body rigidity. The step-down sill construction, life-guard door latches and six-way seat adjustment contributes to body safety, comfort and serviceability.

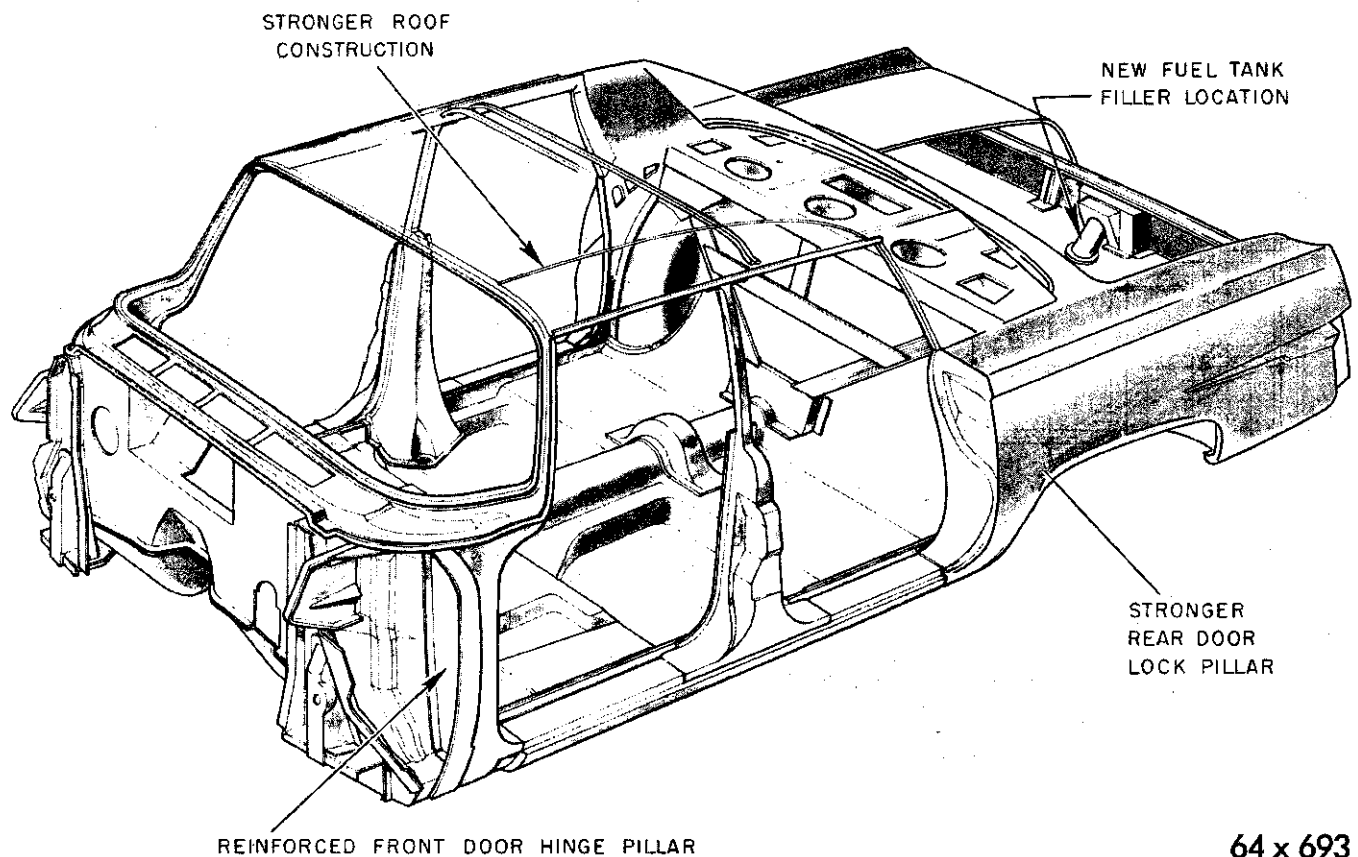

64 x 693

Fig. 2—Basic Body Construction (Imperial)

PART I

BODY MAINTENANCE

1. CLEANING INTERIOR UPHOLSTERY

Most stains can be removed quite easily from fabrics while they are fresh and have not hardened and set into the fabric. An exception is mud or clay, which should be allowed to dry so that most of it can be brushed off. It is also very helpful to know the nature of the staining matter so the proper solvent may be used. Most common stains can be removed with a dry cleaning solvent, such as water solution containing one cup per gallon of a laundry type detergent. Thus, if the nature of the staining matter can only be guessed at and a dry cleaning fluid does not remove the stain, it should be cleaned with one cup per gallon of laundry type detergent in water.

When using a detergent, **do not use one containing a bleach** as this could discolor the fabric. As most detergents contain a certain amount of bleach, caution should be exercised as to the amount used.

Some of the most common upholstery stains can be removed as follows:

(1) **Candy, Chocolate or Ice Cream Stains.** Scrape off as much of the staining matter as possible with a dull knife. Clean with a one-half of 1% solution of a laundry detergent in warm water.

General Instructions: Use a piece of clean cotton cheesecloth approximately 3" x 3". Squeeze most of liquid from the fabric and it is less likely to leave a ring. Wipe the soiled fabric very lightly with a lifting motion. Always work from the outside toward the center of the spot. Turn the cheesecloth over as soon as one side becomes stained to prevent working the staining matter back into the cleaned portion of the fabric. Use a new piece of cheesecloth as soon as both sides become stained.

(2) **Grease, Oil or Tar Stains.** Scrap off as much of the staining matter as possible with a dull knife. Clean the fabric using the recommended cleaner. Be sure the cleaner manufacturer's instructions are followed. Follow General Instructions as listed in No. 1 above.

If grease, oil or tar stains cannot be removed satisfactorily with fabric cleaner on a certain type of fabric, use carbon tetrachloride cleaning fluid. The same procedure can be followed as with fabric cleaner.

(3) **Lipstick or Rouge Stains.** First work white vaseline into the staining matter to loosen it. Then clean with fabric cleaner as recommended in No. 2 above.

(4) **Mud or Clay.** Allow the mud or clay to dry completely. Then, brush it off with a soft bristled brush. Clean with a one-half of 1% solution of detergent in water as recommended in No. 1 above.

When cleaning by any of the methods outlined above, never squeeze the liquid from the cleaning cloth back into the container of cleaning fluid, and never dip the cleaning cloth back into the container of cleaning fluid after the cloth has contacted the stain. Be sure that the cleaning fluid has no impurities and is not discolored before using it. If particles of the staining matter become locked between the fibres of the fabric, it may be necessary to use a clean, soft bristled brush instead of the cheesecloth with the cleaning fluid.

Cleaning of Vinyl Interior Trim

The following are recommendations for cleaning plastic trim:

(1) **Grease, Oil, or Tar Stains.** These stains should be cleaned as soon as possible or they will migrate into the plastic and leave a permanent discoloration on the plastic surface. These stains should be cleaned with either fabric cleaner as recommended above.

(2) The stain grained vinyl should be cleaned as soon as it appears to be getting dirty, otherwise the dirt particles may get rubbed into the small grain crevices and be almost impossible to remove. The dirty vinyl trim should be cleaned with a piece of clean cotton cheesecloth dipped in a sudsy solution of a non-alkaline detergent in water. If the vinyl plastic trim still does not clean up, a clean brush with many fairly stiff bristles should be used in place of the cheesecloth.

Removal of Dirt from White Plastic Trim Panels

The white plastic trim should be cleaned in the same manner as other vinyl interior trim, however, if the dirt has been rubbed into the grain so that it is not possible to remove with the detergent solution, a cleaner may be used. Any abrasive cleaning material will cause the material to peel. To clean use plain water or water with a mild soap solution.

2. PAINT FINISH CARE (All Models)

Dark Spots Appearing on Paint (Metallic)

This condition can be caused by foreign particles

23-6 BODY MAINTENANCE

that are carried through the air and settle on the flat surfaces of the paint.

If any of this foreign substance, containing acid-like particles, is allowed to remain on the paint for any length of time, it may result in a spotting condition. This spotting condition is caused by the reaction of such particles with the aluminum, used in all metallic paints, causing the aluminum flakes to disappear, leaving the base color. These same acid-like particles can also attack a non-metallic paint, but it will usually result in an etched condition rather than a discoloration.

In view of this, it is advisable to wash cars frequently to prevent the possibility of such conditions occurring.

Foreign Material in Paint

In instances where minute particles of foreign material have embedded themselves in the horizontal surfaces of the paint, they are quite likely abrasives, such as metal particles, that have been carried through the air.

If these particles are allowed to remain on the paint surfaces for any length of time in the presence of moisture, a chemical reaction will take place, resulting in the metal particles eating into the paint surface. Early removal of this material by a thorough washing will prevent this from happening.

NOTE: When the above described condition is encountered in the field, it is often mistakenly diagnosed as rust coming up from the metal below the paint.

3. REAR WINDOW (Convertible Coupe)

The rear window is made from flexible vinyl plastic material and special attention should be given to cleaning and storage of the window. To clean the window, rinse with cold water spray to remove grit and dirt. Lather the surface with suds of a mild soap (such as Castile), using the palm of the hand. Rinse thoroughly and allow to air dry. **Do not use a towel, sponge, or chamois to apply suds or to dry the window. Otherwise, the surface may become scratched.** If this procedure does not clean the window thoroughly, a solution of 40 per cent rubbing alcohol and 60 per cent clean water should be used. Apply with palm of hand and rub surface of window with a circular motion. Use solution generously.

4. CARE AND CLEANING OF THE TOP

Frequent brushing and vacuuming will keep the top free of abrasive dust and dirt. Wash top with warm water and mild soap, lathering well with soft cloth or sponge. Rinse with plenty of clean water to remove all traces of soap. Allow to dry completely before lowering.

PART 2
BODY ADJUSTMENTS

5. ALIGNING THE HOOD

An important factor in the alignment of the hood to fenders, is the mounting of the body to frame. Unequal torquing of the body bolts may result in sufficient body distortion to cause misalignment of the hood and fenders.

The upper hinge mounting stud holes are elongated for forward and rearward hood adjustment (Fig. 3). The hood hinge mounting bolt holes in the dash panel are elongated for up or down adjustment of the hood.

Excessive Space Between Rear Edge of Hood and Cowl Panel

(1) To correct this condition, prop the hood open to relieve tension on the hinge springs.

(2) Loosen the bolts attaching the hood to the hinge plate, move hood rearward until correct spacing has been obtained, then tighten attaching bolts securely and inspect fit of hood. (Refer to Fig. 3). When moving the hood forward or rearward, it is suggested that the hood latch adjustment be inspected.

NOTE: Do not remove the prop from under the hood until the hood attaching bolts have been tightened.

Hood Binding at Cowl Panel

(1) Prop the hood open to relieve the tension on the hinge springs.

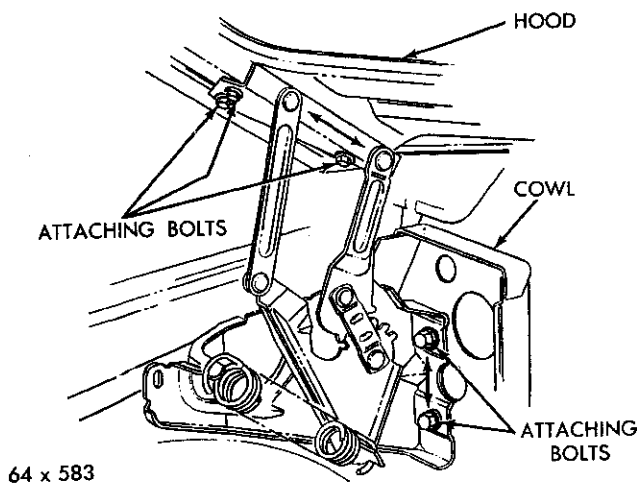

Fig. 3—Hood Hinge Adjustments (Imperial)

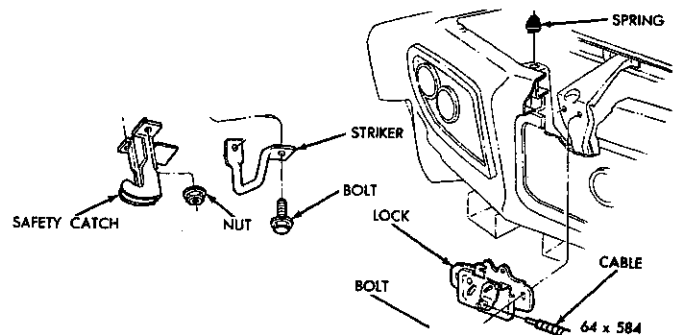

Fig. 4—Hood Lock and Striker (Imperial)

(2) Loosen the bolts attaching the hood to the hinge plate. Move the hood forward until the correct spacing has been obtained, then tighten the attaching bolts securely and test the fit of the hood. When moving the hood forward or rearward, it is suggested that the hood latch adjustment be measured.

NOTE: Do not remove the prop from under the hood until the attaching bolts have been tightened.

Adjustment of Hood Latch and Striker

The hood latch on Chrysler models is located on the fore edge of the hood panel. The latch is attached by two attaching screws.

The attaching screw holes are oversize to permit movement of the latch to assist in alignment of the hood. The latch engages a striker bar attached to the upper radiator grille support.

The hood lock of the Imperial Models is manually operated by a cable and wire assembly (Fig. 4) located under the instrument panel in the driver's compartment. To open, pull on the cable knob enough to allow the hood to snap up to the safety catch. On Chrysler models, the hood latch is operated from under the front part of the hood. Push down slightly on the hood, then trip the safety catch with the fingers to release the hood.

Unequal Spacing Between Rear of Hood and Fenders

(1) Loosen the four hinge to hood attaching bolts on each side of the hood.

(2) Move the hood (at the rear) in the direction of

the wide space, until spacing appears to be equal on each side.

(3) Tighten the hinge to hood bolts, lower the hood and test for the correct fit.

If the spacing is correct on one side but too little or too much on the other side, loosen the bolts attaching the hood to hinge and the diagonal brace on the side to be adjusted. (If the hood needs to be moved out, insert a large screw driver between the upper hinge plate and the hood flange. Force the hood out as required while holding pressure on the screw driver, and tighten the bolts securely.

To move the hood in, apply pressure on the outside edge of hood, then tighten the bolts securely. Lower the hood and test the hood for a proper fit.

Hood Projects Beyond Front of Fender

Location is correct at the cowl but the hood projects beyond the front fender and the fender to door spacing is too close. The fender can be moved forward with a standard bumper jack, having a 10½ inch long piece of steel welded to its base.

(1) Loosen the bolts that hold the front fender to the cowl side panel.

(2) Place the extended end of the jack against the hinge bracket on the side cowl panel, and lifting the lug of the jack against the upper section of the radiator support.

(3) Extend the jack carefully, measuring the clearance between the rear edge of fender and the leading edge of the front door. When the spacing between the door and the fender is correct, tighten the fender to cowl bolts securely.

(4) Remove the jack and lower the hood.

Front of Hood Higher than Fenders

If this condition is apparent, inspect the rear edge of the hood to see if it is low at the cowl or spaced properly. If the hood to cowl adjustment is correct, inspect the hood latch and striker bar. If the hood latch is raised, the hood will be drawn down. It will be necessary also to adjust the hood bumpers on both sides when adjusting the hood.

Hood Side Contour Does Not Follow Fender

When the side contour of the hood does not follow the curve of the fender, the hood should be reshaped.

(1) Insert a small block of wood (about 1 inch square) between the fender flange and hood, just opposite the low spot on the hood.

(2) Close the hood slowly. With the hands placed just ahead of the block, gently apply pressure to the hood.

(3) Repeat this operation about every six inches

until the contour of the fender and hood conform evenly.

Fender Below Level of Hood at Front End

If the hood has been properly adjusted and one fender is still below the level of the hood at the front, the fender should be raised.

(1) Raise the hood, then loosen the bolts that hold the fender to the radiator support.

(2) Wrap a cloth around the lifting lug of the service jack and install under front lower corner of the fender.

(3) Raise the jack until the fender is in the correct position. Leave the jack in place and tighten the fender bolts securely.

(4) Lower the jack, close the hood and inspect the fit.

(5) Adjust the hood bumpers as required.

6. ALIGNING DOORS (All Models)

All models are equipped with a newly designed cam and roller type door hinges providing full or intermediate check of door openings with tapered floating hinge plates located behind the hinges in the body pillars for the centering or aligning of the doors.

(1) Make a thorough inspection of the door before attempting adjustment. A properly fitted door has evenly spaced gaps on all sides.

(2) Test the engagement of the door latch with the striker plate.

(3) The door should raise slightly as the latch passes over the plate.

(4) The striker plate, as shown in Figure 5 can be moved "in" or "out" and controls the tightness of the door against the body.

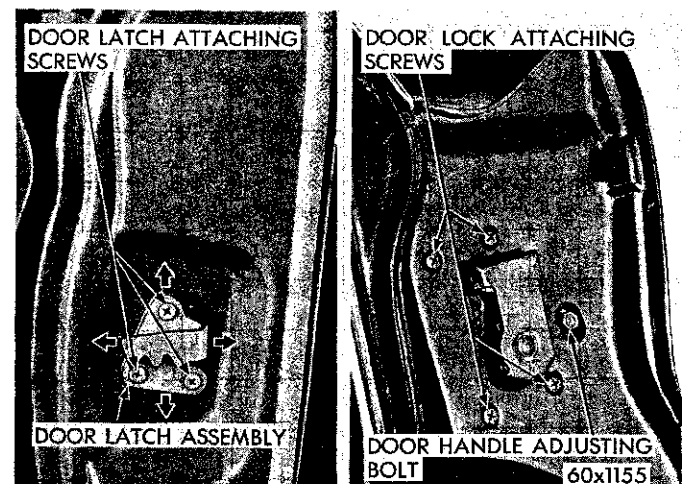

Fig. 5—Door Lock Rotor and Striker Assembly

(5) The "up" and "down" adjustment will determine the actual point of engagement between the door lock rotor and the lower portion of the striker plate.

(6) Each hinge is attached to two floating plates, one located at the front pillar and the other at the door panel.

(7) "Up" or "down" adjustment of the door can be made at the front pillar or in the door itself.

NOTE: "Forward" or "Rearward" adjustment can be made only at the door. "In" or "out" adjustment can be made at the front pillar only.

(8) After the door has been fitted properly to the opening, adjust the striker plate as necessary.

7. TO RAISE OR LOWER DOOR (Front Doors)

- (1) Remove the trim panel.
- (2) Place a jack under the door as near the hinge as possible. (This will hold the weight of the door as the hinge bolts are loosened).
- (3) Scribe a line around the upper and lower hinge.
- (4) Loosen the upper and lower hinge bolts (Fig. 6).

The amount of vertical movement in the door is limited; however, the amount of movement can be determined by the scribed line previously made.

(5) Raise or lower the jack until the desired clearance is obtained then tighten the hinge bolts securely.

NOTE: Measure the scribe lines to make certain

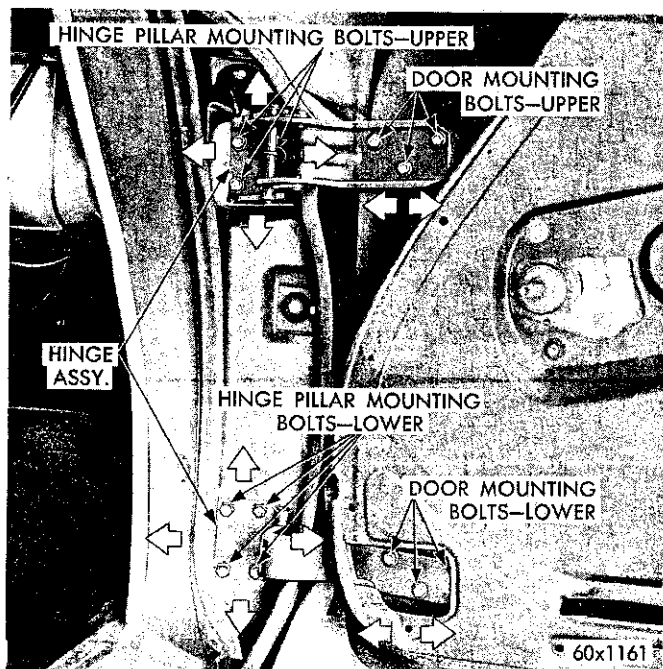

Fig. 6—Front Door Hinge Assembly (Chrysler)

the rear portion of the door did not move forward or rearward.

8. MOVING THE DOOR FORWARD OR BACK (Front Door)

(1) Moving the door forward or rearward is accomplished by loosening either the upper or lower hinge bolts. (See Fig. 6).

(2) To move the upper portion of the door forward or back (trim panel removed), loosen the upper hinge bolts and either pull or push the upper portion of the door in the desired direction.

(3) Tighten the hinge bolts and inspect the fit.

(4) To move the lower portion of the door forward or rearward (trim panel removed), loosen the lower hinge bolts and either pull or push the lower portion of the door in the desired direction.

(5) Tighten the hinge bolts and inspect the fit.

(6) When correct, reinstall the door trim panel.

9. FITTING THE FRONT DOOR FLUSH WITH ADJACENT PANELS

(1) If the door is not flush with the adjacent panels, correct by loosening the four hinge bolts (on the front door pillar or the three hinge bolts on the rear door pillar).

(2) When loosening the upper hinge and pulling "out" or pushing "in" on the front upper corner of the door, the lower corner of the door will be moved inward or outward also. The opposite corners of the door will also be affected in a similar manner when the lower hinge is moved "in" or "out". This applies to both the front and rear doors.

10. FINAL DOOR STRIKER PLATE ADJUSTMENT

(1) After the door has been centered in its opening and all the hinge bolts have been tightened 18 to 20 foot pounds torque, test the door for ease of opening and closing.

(2) To adjust, move the striker plate "in" or "out", "up" or "down" as necessary (Fig. 5) until easy operation is obtained, and the door fits snugly against the weatherstrip.

(3) Be sure the top surface of the striker plate is parallel with the bottom of the door latch nylon wedge in the rotor housing.

(4) The striker plate is properly positioned when the door has a very slight lift as it is closed.

(5) If proper adjustment cannot be obtained, the use of shims between the latch plate and pillar

23-10 BODY ADJUSTMENTS

should be used. The shims are available in $\frac{1}{32}$ and $\frac{1}{16}$ inch thickness. (The shims are used to bring the latch plate closer to the door for full engagement).

(6) The door weatherstrip seal may be tested by holding a heavy piece of paper (similar to a shipping tag) against the lock pillar and then closing the door.

(7) This paper test should be made all around the door at approximately six-inch intervals.

(8) A slight drag should be felt as the paper is being pulled out.

(9) If no drag is felt, move the striker plate in closer.

(10) If no drag is felt on the paper, after adjusting the striker, make the necessary adjustments to either or both hinge pockets.

11. REAR DOOR ADJUSTMENTS

(1) To move the door "up or "down" in the body opening or to move the door "in" or "out" to bring the door panel flush with the body. Loosen the hinge attaching bolts at the rear door hinge ("B") pillar.

(2) Move the door as required to obtain the proper fit with the door opening.

(3) Tighten the bolts securely.

12. DECK LID ALIGNMENT

The deck lid hinges, lock and striker plate are adjustable, enabling a proper fit of the deck lid with little effort.

13. CENTERING DECK LID IN OPENING

On Chrysler Models, the two bolts in each of the deck lid hinges are slightly oversized, thereby permitting the lid to be moved ahead or back. On Imperial Models, (Fig. 7), the rear attaching bolt hole is elongated to allow fore and aft adjustment. The front attaching bolt hole is enlarged to permit fore and aft adjustment and up and down adjustment. When positioning, locate the lid so the extreme rear portion along the sides are both flush with the body panel as well as equally spaced in the opening. To adjust, loosen the hinge bolts (one hinge at a time) as shown in Figure 7. Move the lid in the desired direction, retighten the bolts. Repeat this operation on the opposite side until the lid fits flush with the body panel and is equally spaced all around.

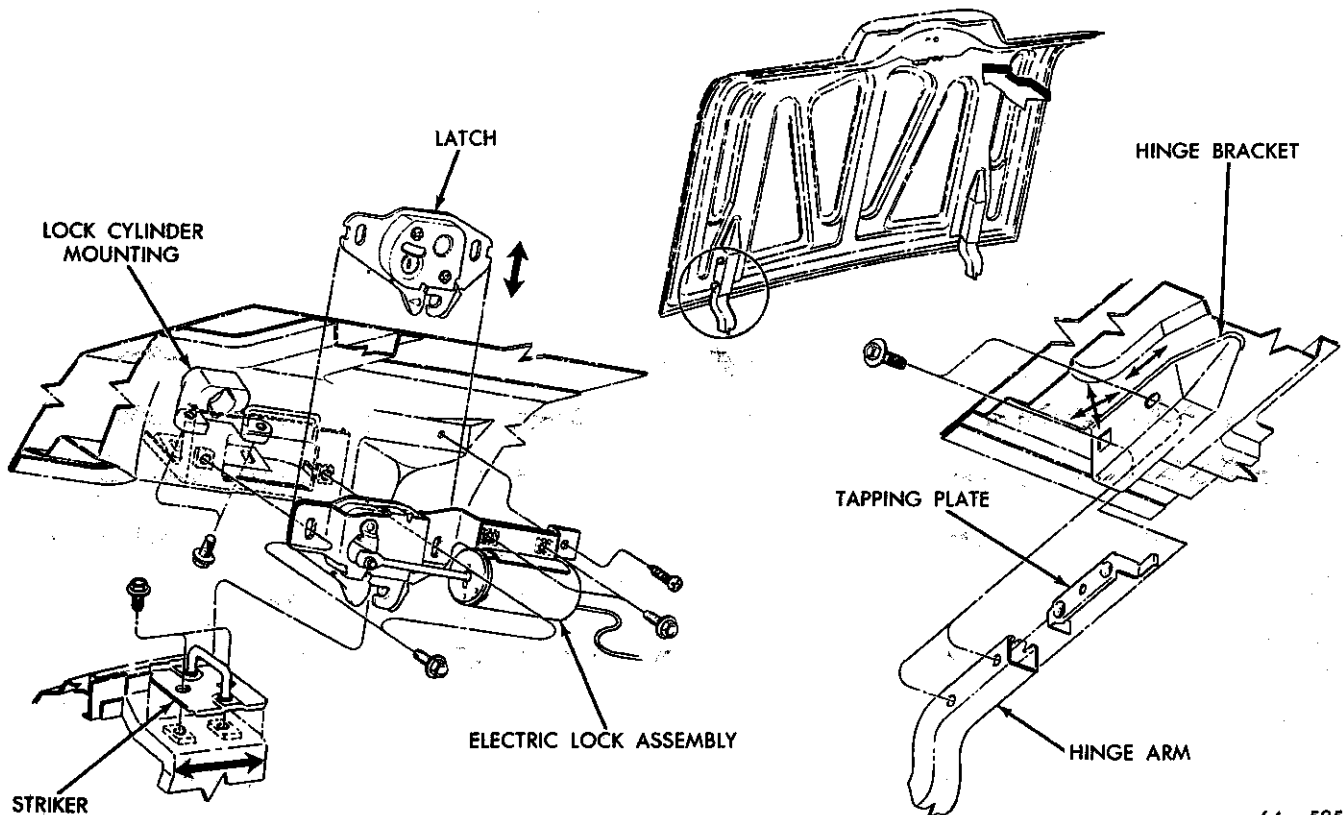

Fig. 7—Deck Lid Adjusting Points (Imperial)

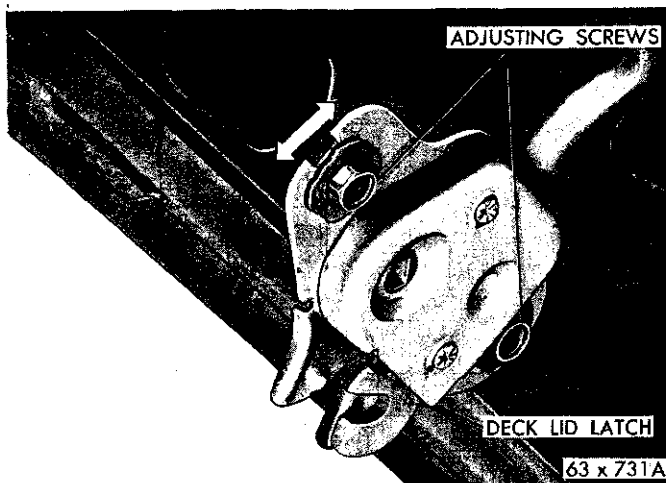

Fig. 8—Deck Lid Latch Adjustment

Raising or Lowering the Upper Corners of Deck Lid

To Raise—If either of the upper corners are too low, open the deck lid and loosen the bolts that hold the hinge bracket. Insert a small fiber block under the low corner between the lid and side panel. Slightly lower the lid. Tighten the bolts and inspect the fit.

To Lower—Raise the deck lid and loosen the bolts. Press down on top of the deck lid at the high corner until the correct fit has been obtained. Tighten the bolts, test the adjustment of the latch and the striker plate.

Adjusting the Latch and Striker Plate

Both latch and striker plate are adjustable, but better results can be obtained by adjusting the striker plate. The striker plate is adjustable in two directions, forward and backward, and to either side, as shown in Figures 7 and 8. As the plate moves to the rear, it also rises making it easier to close the lid. Moving the plate forward lowers it and makes the lid close tighter.

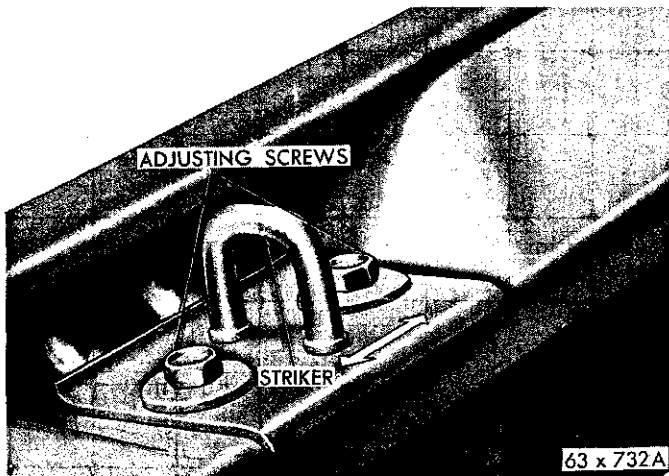

Fig. 9—Deck Lid Striker Adjustment

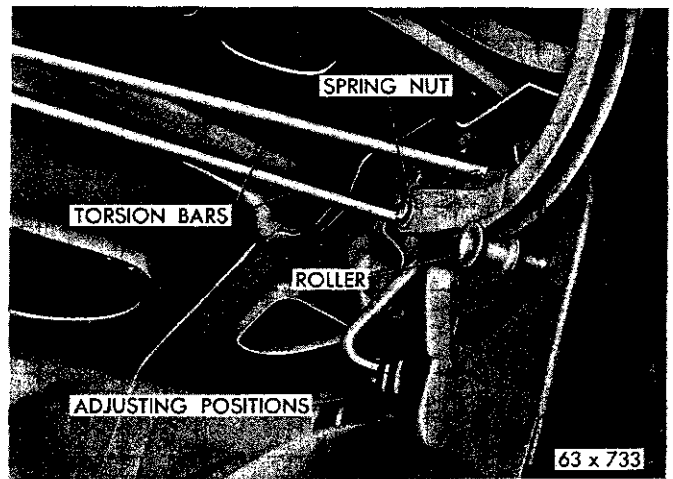

Fig. 10—Deck Lid Hinge and Torsion Bar

Adjusting the Latch

Loosen the mounting bolts, as shown in Figures 7 and 9, and move the latch into the proper engaging position. Tighten the bolts securely.

Inspecting for a Correctly Fitted Deck Lid

A correctly fitted deck lid is one that is centered in the opening, and fits flush with the body panels. A test for proper fitting and seal of the deck lid can be made with strips of paper. Insert the strips of paper (about an inch wide) along the edge of the deck lid opening and close the lid. If the papers fit snug all along the edges of the lid as they are pulled out, a good seal is evident. If the papers fit loosely on one side, and tight on the other, the deck lid should be aligned.

Deck Lid Torsion Bar

The weight of the lid is counterbalanced in all posi-

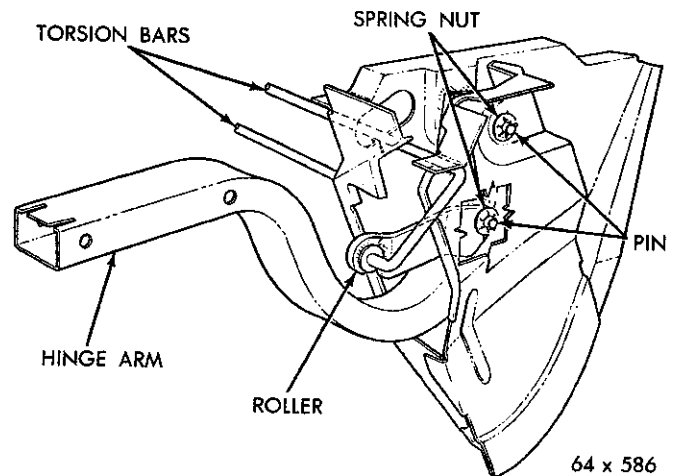

Fig. 11—Deck Lid Hinge and Torsion Bar (Imperial)

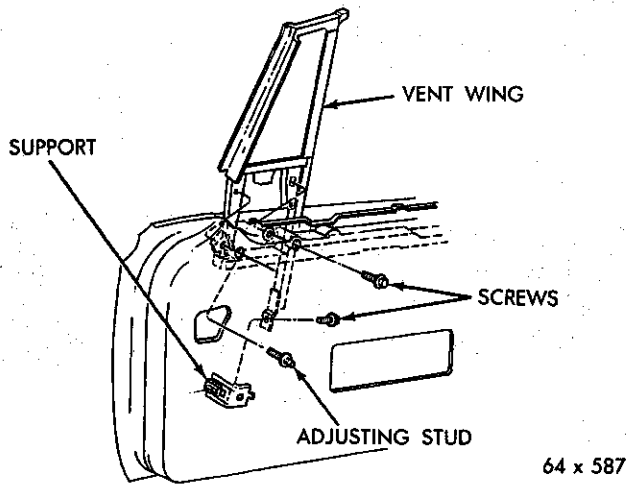

Fig. 12—Vent Wing Assembly (Imperial)

tions by the tension of two torsion bars. (See Figs. 10 and 11.) The torsion bars are long, small diameter steel bars, that are free at one end and anchored to support the bracket at the other. A roller sleeve on the free end, operates against a "camcontour" on the back face of the hinge. As the deck lid is raised, the action of the rollers against the hinges cause the bars to twist, exerting a torsional resistance that balances the lid. To permit adjustment of the torsion bar tension three slots are located in each support plate (Fig. 10).

14. VENT WING FRAME AND DOOR GLASS ADJUSTMENT (Imperial Models) (Figs. 12 and 13)

NOTE: Align the front door with the "A" post and cowl prior to making any adjustments to the vent wing frame.

- (1) Remove the inside remote control handle.

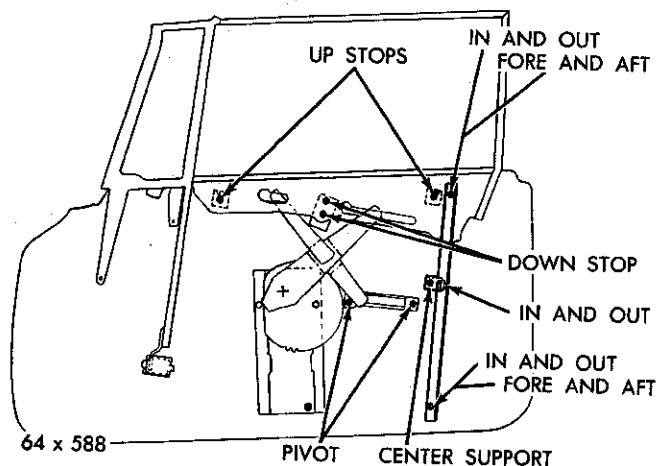

Fig. 13—Door Glass Adjustments (Imperial)

- (2) Remove the inside upholstery trim panel and weather shield.

- (3) Close the door and observe the direction the vent frame must be moved to align the frame with the "A" post and also make a good weather seal at the roof rail weather seal.

- (4) Loosen the forward attaching screws and the division bar adjusting stud locking nut and washer (Fig. 12).

- (5) Run the door glass to the down position and move the vent wing fore or aft position to make the correct alignment with the "A" post.

- (6) Holding the vent frame in position, tighten the two forward adjusting screws to 40 inch pounds torque.

- (7) To move the top of the vent frame inboard, turn the division bar lower adjusting stud counter-clockwise. To move the top of the vent frame outboard turn the adjusting stud clockwise.

- (8) With the vent frame in position at the "A" post and making a good weather seal at the roof rail tighten the division bar adjusting stud lock nut and washer 30 to 50 inch pounds torque and retighten the two forward attaching screws 80 to 120 inch pounds torque.

- (9) Run the door glass to the up position and test for ease of operation.

- (10) Turn the upper rear roller track sleeve nut until the rear of the glass touches lightly on the cat whiskers at the belt line of the door outside panel.

- (11) Run the window, with the door closed, seating the glass fully against the roof rail weatherstrip and with the top of the glass flush with the top of the vent wing.

- (12) Adjust the lower frame parallel to the belt line of the door outside panel.

- (13) Tighten the pivot bracket screws securely.

- (14) Adjust the up stops down against window lower frame.

- (15) Adjust the upper rear roller track forward so the glass is seated in the vent wing channel.

- (16) Run the window down fully.

- (17) Adjust the lower rear roller track sleeve nut until its boss is against the outboard side of the door inner panel.

- (18) Move the track forward until the glass is seated in the vent frame channel and tighten the nut.

- (19) Adjust the down stops so the glass is slightly below the belt line.

- (20) Loosen the center support to roller track screw

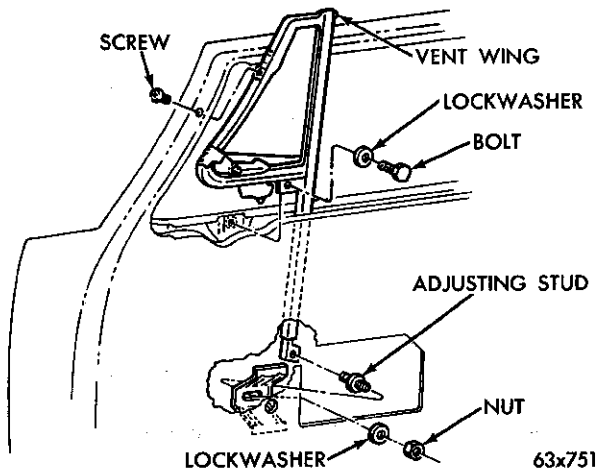

Fig. 14—Vent Wing Assembly (Chrysler)

and move the support against the inside panel. Tighten the support screw securely.

- (21) Operate the window and inspect the alignment and operation.
- (22) Install the door inside, trim and hardware.

15. FRONT DOOR VENT WING AND DOOR GLASS ADJUSTMENT HARDTOP (Chrysler Models)

- (1) Remove the remote control handle, trim panel, and garnish moulding.
- (2) Loosen the vent wing attaching bolts and divisional bar adjusting nut. (Fig. 14).
- (3) Position the vent wing assembly in the door opening to line up with the front door post and roof rail.
- (4) Tighten the attaching screws and divisional bar nut.
- (5) Inspect the vent wing for proper alignment.
- (6) Raise the window and inspect alignment with the roof rail and weatherstrip.

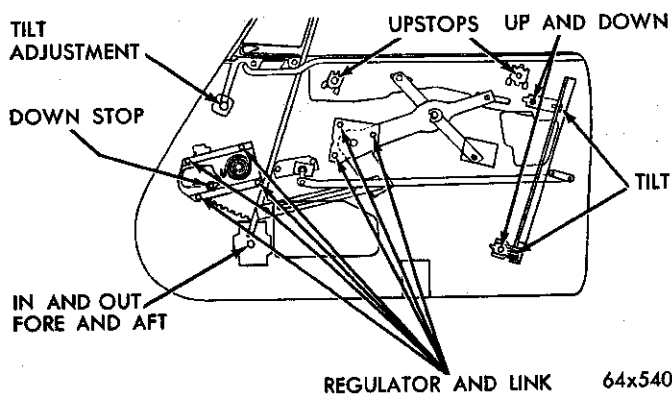

Fig. 15—Door Glass Adjustments (Chrysler)

(7) Adjust the rear guide upper adjustment (Fig. 15) to align the window with the outer edge of the weatherstrip so that only light contact is maintained with the lip of the weatherstrip.

(8) Adjust the rear track (Fig. 15) in and out adjustment to line the glass up while positioning the window glass up against the roof rail weatherstrip.

(9) Adjust the rear track to a forward and rearward position to hold the glass partially snug.

(10) Reposition the regulator pivot to correct the window misalignment as required to fit the roof rail contour.

(11) Reset the upper and lower stops.

NOTE: It may be necessary to realign the rear door window glass opening to conform with the front glass alignment for the perfect fit.

(12) Raise and lower the glass a couple of times and test for proper fit.

16. REAR DOOR GLASS ADJUSTMENT (Hardtop) (Imperial Models) (Fig. 16)

With both front and rear doors closed, observe the alignment of the rear door glass with the front door and the roof rail weather seal then adjust.

- (1) Remove the remote control door handle and the remote lock lever.
- (2) Remove the trim panel and disconnect the window regulator switch, (if so equipped) and remove the weather shield.
- (3) Loosen the lock nut of both upper guide track adjusters.
- (4) Raise the door glass approximately three-fourths of the way up.

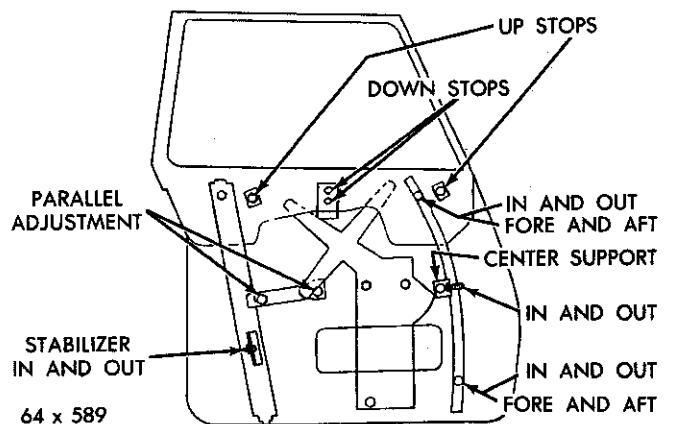

Fig. 16—Rear Door Glass Adjustments (Imperial)

23-14 BODY ADJUSTMENTS

(5) Turn the upper track attachment nut until the rear of the glass touches the cat whiskers lightly at the door outside panel side.

(6) Raise the window fully and adjust the lower stabilizer (in or out) so that the front of the glass is aligned with the rear of the front door glass at the roof rail area.

(7) Adjust the regulator pivot bracket so that the front edge of the glass is parallel to the rear edge of the front door glass.

(8) Adjust the upper track attachment forward until the glass weatherstrip is forward against the front door glass.

(9) Adjust the door glass up stops.

(10) Lower the window until the top edge of the glass is slightly below the belt line of the door outside panel.

(11) Adjust the lower track until the boss of the track sleeve nut is against the inside panel.

(12) Adjust the door glass down stops.

(13) Operate the door window and inspect alignment and operation.

(14) Install the door trim panel and hardware.

17. REAR DOOR GLASS ADJUSTMENT (Hardtop) (Chrysler Models) (Fig. 17)

With both front and rear doors closed, and the glass in the **UP** position, observe the alignment of the rear edge of the front glass and the front edge of the rear door glass. Compare the height of both glass and the contact of the rear glass with the lip of the roof rail weather seal.

(1) Remove the inside handles and remote lock lever.

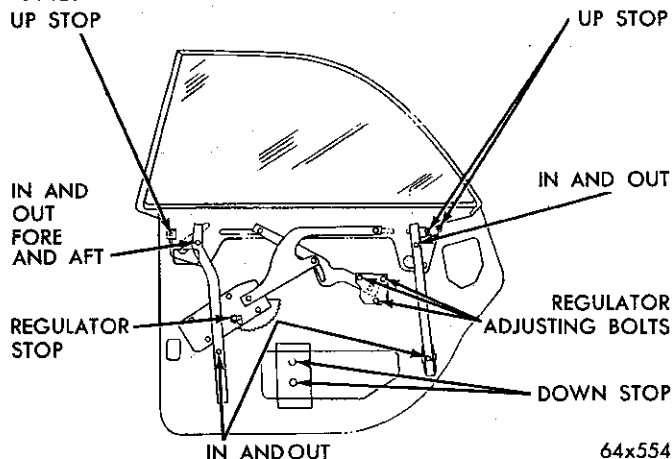

Fig. 17—Rear Door Glass Adjustments
(Chrysler-Hard Top)

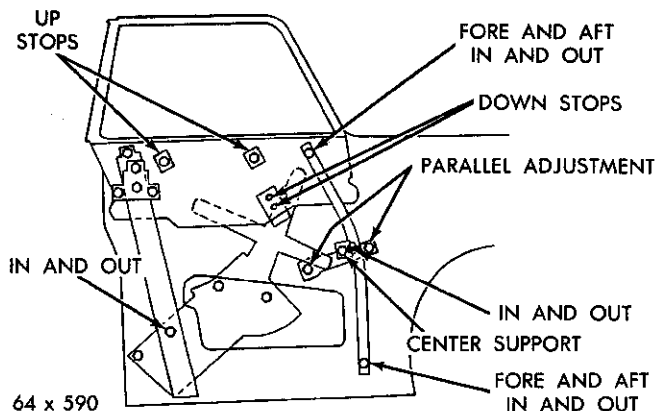

Fig. 18—Quarter Glass Adjustments (Imperial)

(2) Remove the upholstery trim panel and weather shield.

(3) Loosen the upper and lower channel adjusting screw lock nuts.

(4) Run the upper channel adjusting screws either "in" or "out" so that the glass makes light contact with the door upper weather seal.

(5) Remove the channel adjusting screws either fore or aft until the front edge of the rear door glass evenly contacts the seal of the front glass.

(6) Tighten the locking nuts of the upper adjusting screws.

(7) Adjust the lower track adjusting screws so that the top edge of the glass seals against the lip of the roof seal. Turning the screw in will move the top of the glass inboard and turning the screws out will move the top of the glass inboard and turning the screws out will move the top of the glass outboard.

(8) Tighten the locking nuts, install the weather shield, upholstery trim panel and install the inside handles and remote lock lever.

18. QUARTER GLASS ADJUSTMENT (Imperial Models) (Fig. 18)

(1) Remove the rear seat cushion seat back and the upholstering quarter panel and weather shield. Disconnect the wires from the window regulator switch.

(2) Close the door and raise the quarter window to the three quarter closed position.

(3) Adjust the upper track attachment until the rear of the glass touches lightly on the cat whiskers at the outside panel.

(4) Raise the window fully and adjust the lower frame so it is parallel to the belt line of the quarter outside panel.

(5) Adjust the lower stabilizer attachment until the front of the glass is aligned with the rear of the front door glass at the roof rail.

(6) Adjust the regulator pivot bracket (up or down) so the top of the glass is fully against and parallel to the roof rail weatherstrip.

(7) Adjust the **UP** stops against the lower window frame.

(8) Lower the window until the top edge of the glass is slightly below the belt line.

(9) Adjust the lower track attachment until the boss of the sleeve nut is against the inside panel.

(10) Adjust the center support, at the roller track, against the inside panel.

(11) Operate the window and inspect the alignment and operation.

(12) Install the weather seal, trim panel, hardware and rear seat back and seat.

19. QUARTER GLASS ADJUSTMENT (Chrysler Models) (Fig. 19)

(1) Remove the rear seat cushion, seat back, the regulator handle, the quarter panel trim and weather shield.

(2) Loosen the roller guide attaching nuts on both front and rear guide tracks.

(3) Run the window up and test the alignment of the door and quarter glass and roof rail weather seal.

(4) Turn the upper sleeve nuts "in" or "out" so that the glass makes light contact with the belt line weather seal (Turn the sleeve nut clockwise to move the glass inboard and counter-clockwise to move the glass outboard).

(5) Move the guide tracks forward to align the quarter glass to the rear of the door glass.

(6) Tighten the locking nuts of the guide sleeve nuts.

(7) Run the glass "up" and "down" several times and test the "up" and "down" several times and test the "up" and "down" stops.

(8) Install the weather shield, trim panel, the regulator handle, rear seat back and seat cushion.

20. HOOD Removal (Fig. 3)

NOTE: Before removing the bolts, mark the outline of the hinges on the hood, using a soft pencil or wax crayon. This will aid in the hood alignment when reinstalling.

(1) Raise the hood and remove the bolts and washers attaching the hood to the hinge arms (both sides). Leave one bolt and washer on each finger loose.

(2) Brace the hood in such a manner that the hood

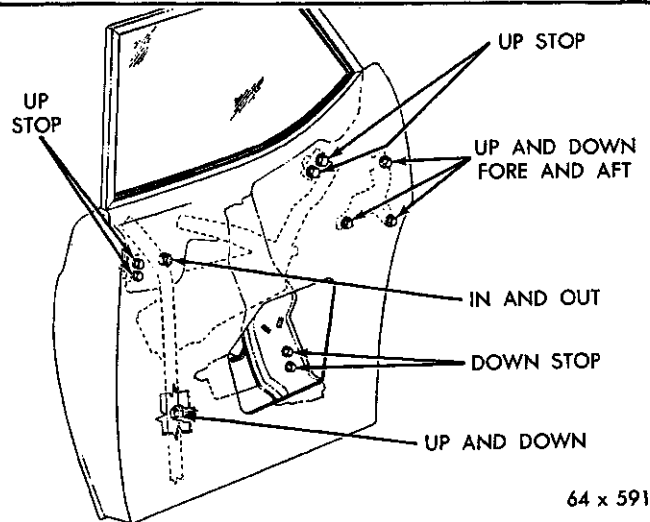

Fig. 19—Quarter Glass Adjustments (Chrysler)

will not slide to the rear and damage the painted surface of the cowl or fenders.

(3) After the hood is braced properly, remove the last two bolts and washers. Lift the hood up and away from the vehicle.

Installation

When installing the hood, the same precautions as taken above, should be followed.

Lift the hood and slide into position, brace securely, then install the attaching bolts and washers. Just snug down. Do not tighten. Align the hood with the marks previously made, then tighten the attaching bolts securely.

21. HOOD HINGE

Removal

(1) Repeat the above steps for hood removal, making certain the hinge location has been scribed on both the hood and cowl panel.

(2) Remove the hinge to cowl bolts and remove the hinge.

NOTE: Do not attempt to remove the hinge spring from the hinge as the hinge assembly is serviced as a unit.

Installation

(1) Place the hinge assembly on the cowl and install the attaching bolts finger tight.

(2) Place the hood on the hinges and install the attaching screws finger tight.

(3) Align the hinge with the scribe mark on the cowl and tighten the attaching screws.

(4) Align the hood and hinge scribe marks and tighten the attaching screws.

(5) Lubricate the hinge and adjust the hood alignment.

PART 3

BODY SEALING

22. WEATHERSTRIP ADHESIVE

This cement may be used where a strong bonding of rubber parts to painted or unpainted steel surfaces is desired. It can be used for such purposes as the attachment of weatherstripping on doors and luggage compartment lid or for the attachment of felt pads.

NOTE: Before sealing, always clean all surfaces to be cemented with unleaded gasoline. Do not use kerosene as this liquid leaves a thin film of oil which will prevent adequate adhesion of the sealer.

23. WINDSHIELD RUBBER CEMENT

A heavy viscosity, black, rubber cement. This cement is used where glass is confined in the rubber

weatherstrip, such as on the windshield and rear window to eliminate glass chatter and water leakage. This cement will not harm paint or chrome finish and can easily be removed with a cloth moistened with solvent.

24. GENERAL SEAM SEALING MATERIAL

Body caulking gray putty sealer, used for body seam and joint—require areas for sealing to be free of dirt, moisture and foreign matter. Sealer must be pressed firmly into seam to effect a proper seal.

25. GASOLINE RESISTANT SEALER

Used in areas subject to gasoline spillage such as filler housing door.

26. WATER AND DUST LEAKAGE AREAS

Windshield and Rear Window Weatherstrip—Glass to Rubber (Figs. 20 and 21)

To eliminate glass chatter and water leakage between glass and rubber weatherstrip, it is recommended to lift the lip of the rubber weatherstrip where it contacts the glass, using a nozzle type applicator and force a continuous $\frac{1}{8}$ " diameter bead of windshield rubber cement deeply around the entire edge of glass, as shown in Figure 21.

Windshield and Rear Window Weatherstrip (Figs. 21 and 22—Rubber to Body and Moulding Attaching Clips)

Remove the outside finish mouldings; and apply a

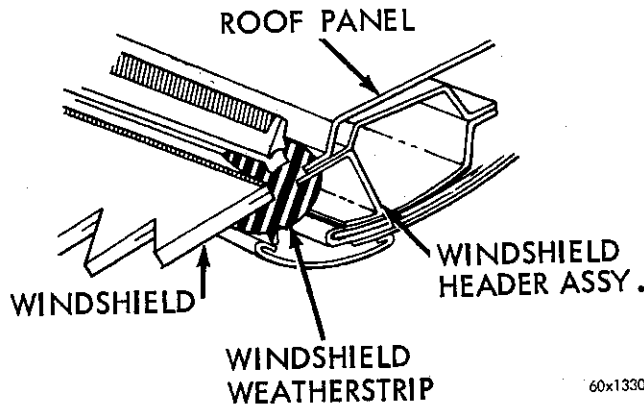

Fig. 20—Windshield Weatherstrip Sealing

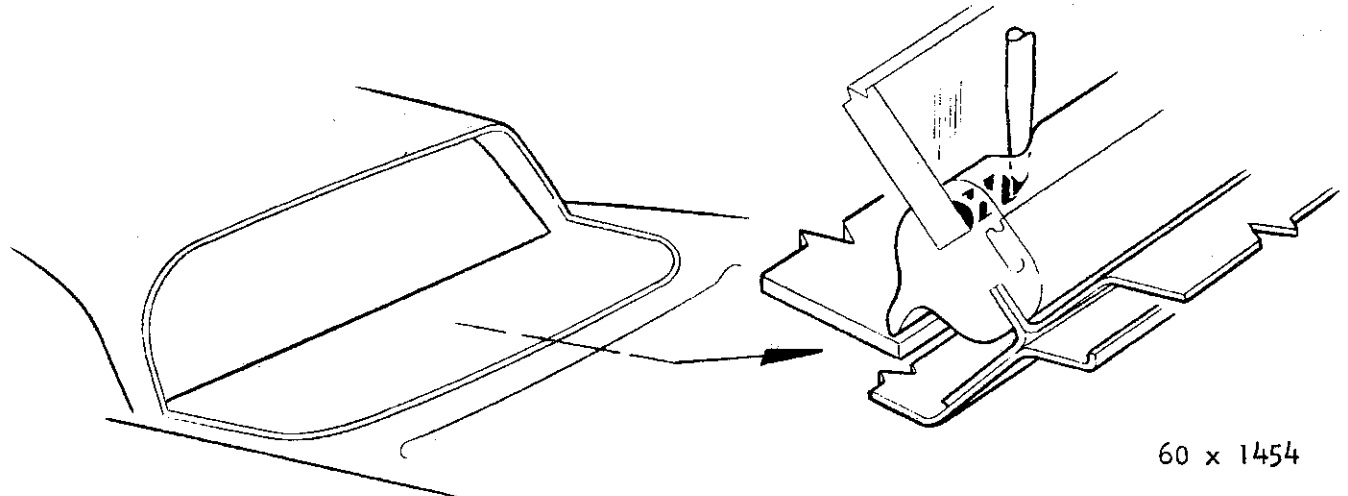
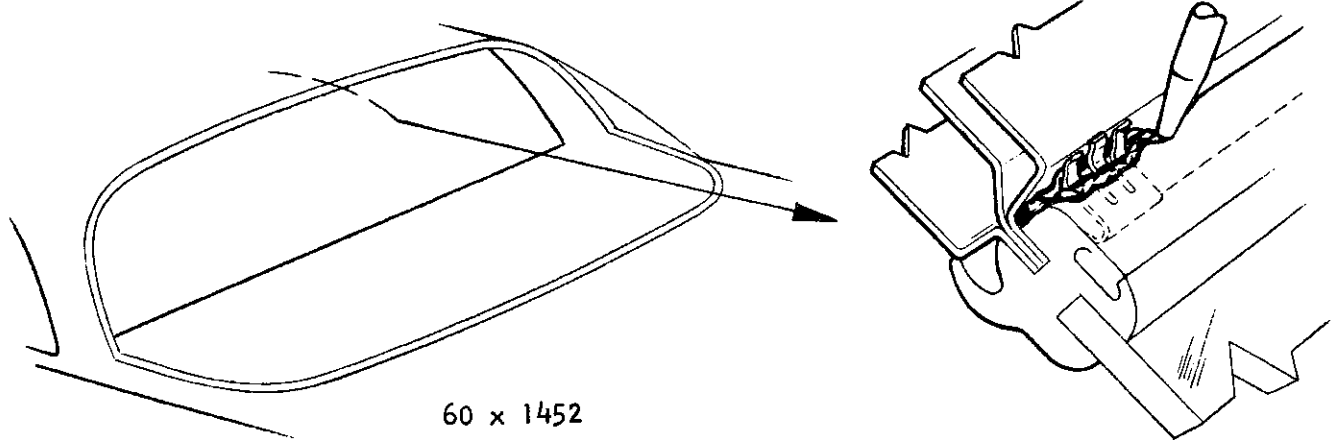

Fig. 21—Rear Window Weatherstrip Sealing (Lower)



60 x 1452

Fig. 22—Rear Window Weatherstrip Sealing (Upper)

continuous $\frac{1}{8}$ " diameter bead of windshield rubber cement around entire edge of rubber to body opening fence. It is recommended to take particular caution to apply an ample amount of cement around each moulding attaching clip.

Windshield Weatherstrip Sealing (Fig. 23)

Seal the weatherstrip against the body opening by carefully working a thin coating of body seam sealer between the body edge and the rubber moulding, or lift the lip of the rubber weatherstrip where it contacts the body metal. Use a nozzle-type applicator (sealer gun) to force the sealer deeply around the entire edge. It is seldom necessary to reseal between the glass and the weatherstrip, unless the glass has been replaced. If faulty sealing of the glass to the

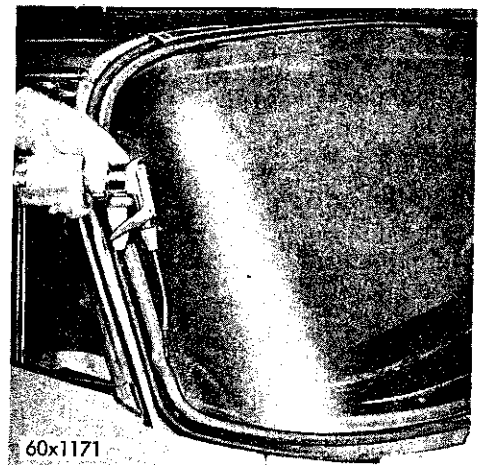

60x1171

Fig. 23—Sealing the Windshield Weatherstrip

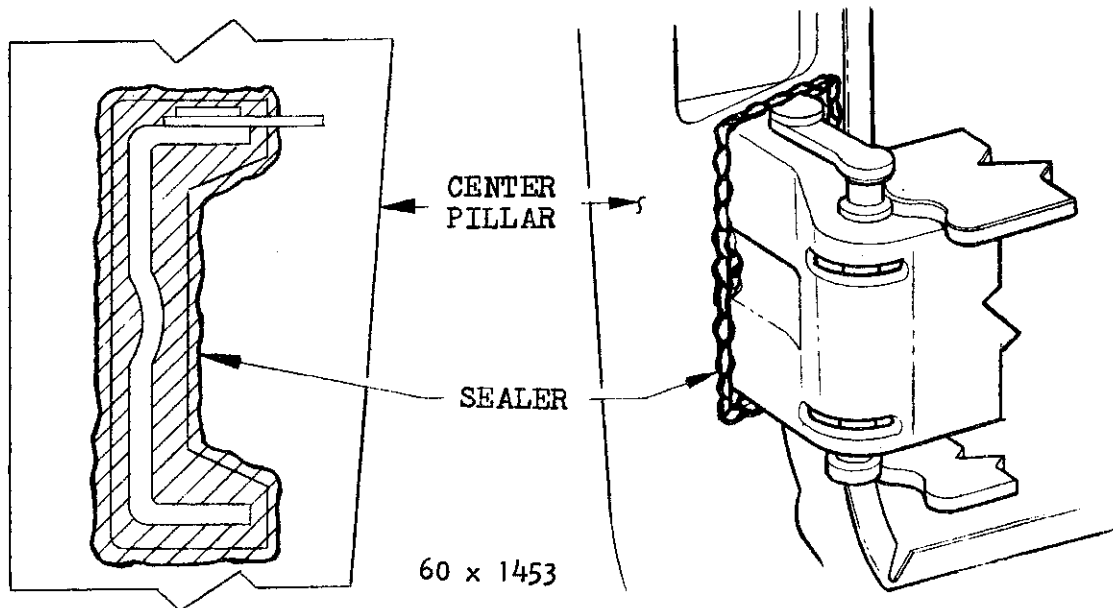

60 x 1453

Fig. 24—Rear Door Hinge Sealing

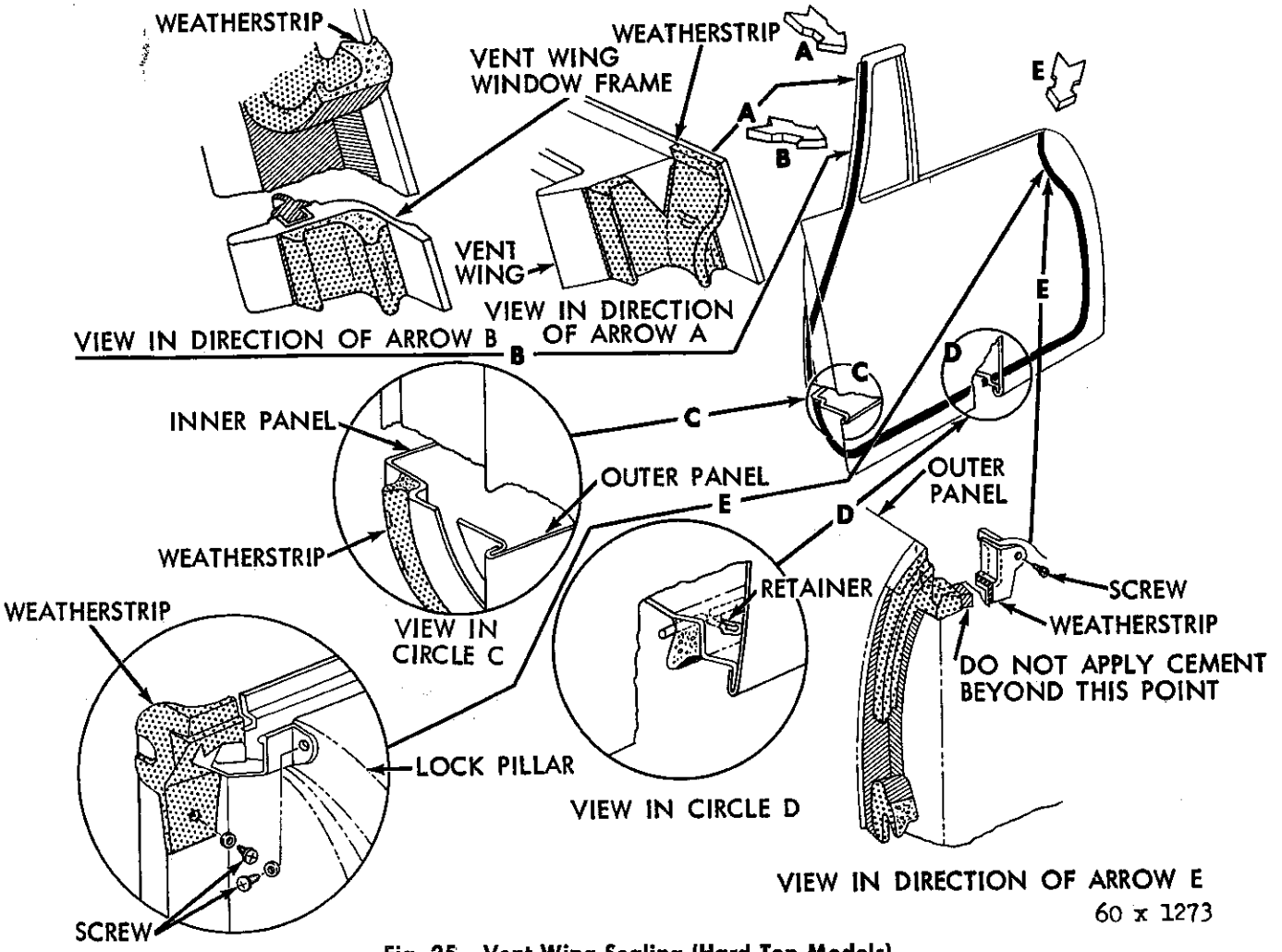

Fig. 25—Vent Wing Sealing (Hard Top Models)

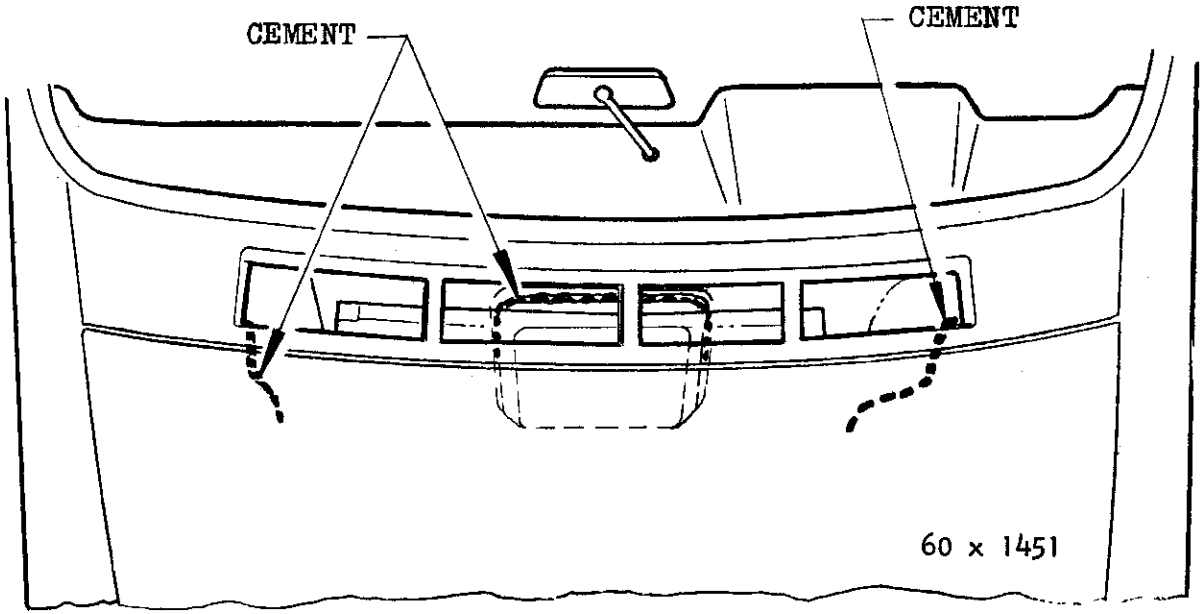

Fig. 26—Cowl Panel Sealing

weatherstrip has caused a leak, remove the windshield finish moulding and apply sealer as far down as possible between the inner weatherstrip and the glass for a considerable distance on each side of the leakage point (Fig. 23). Clean off excess sealer with a rag. Reinstall the finish mouldings and inspect for proper seal.

Door Hinges at Center Pillar (Fig. 24)

Inspect the sealer where the rear door hinge enters through the center pillar. This should be done after the door fitting, as the sealer may become cracked or loose. The seal around the hinge should be an air tight seal. Reseal if necessary with body caulking putty sealer.

Seal all openings and joint seams on the inside of the luggage compartment lower panel, especially the back-up lamp wire grommets. Seal all luggage compartment floor panel seams with liquid body sealer. Seal between the luggage compartment lower panel and door panel with body caulking sealer. Make sure all plugs and grommets are properly installed.

Front Door Vent Wing (Fig. 25)

Leaks through the vent windows can be located by a water test. After locating the leak area, inspect the condition of the vent weatherstrip, the fit of the vent glass in the vent opening, and the compression of the vent glass weatherstrip.

In most cases simple adjustments will correct the leaks between the vent glass and the weatherstrip. To increase the pressure of the glass against the upper portion of the weatherstrip, install shims made from rubber shim stock and place between the upper vent pivot brackets and the outside of the vent glass.

Application of black mastic or body sealer to the corners of the vent weatherstrip generally corrects the leak in this area if the weatherstrip overlaps. If the weatherstrip is severely damaged, install a new vent wing weatherstrip.

Leaks around the pivots can be corrected by the use of black mastic sealer. Fill the openings in the weatherstrip where the vent pivot goes through the weatherstrip. Seal around the upper pivot bracket at the door frame and at the junction of the division bar and door frame.

The most important requirement to obtain a good water-tight seal between the door window frames and the roof rail weatherstrip is precise adjustments of the doors, the window frames and channels. Adequate adjustments are provided for up and down, in and out, and forward and rearward adjustment of the window frames. It is important that the weatherstrip has sufficient pressure against the frame, but too great pressure may push the window frame out of

alignment and will prevent proper contact with the mating window weatherstrip.

Cowl Top and Fresh Air Plenum Chamber Area Leakage (Fig. 26)

In most cases, water leakage at the heater system rubber fresh air door is caused by ineffective sealing of the fresh air water deflector trough to dash panel. To seal this area, remove the fresh air intake screen and reach into plenum chamber with a sealing gun, flowing a $\frac{3}{16}$ " diameter bead of windshield rubber cement to the sides and top of the deflector trough to dash panel seam.

If water enters around the dash panel with fresh air intake screen removed, flow a $\frac{3}{16}$ " diameter bead of windshield rubber cement between the top of the plenum chamber cover and dash panel seam (lefthand side). To prevent water entering the blower system, flow a $\frac{3}{16}$ " diameter bead of windshield rubber cement to the top and sides of the plenum cover to the dash panel (Fig. 27).

If water enters around the booster brake to dash panel assembly or the heater plenum cover, flow a $\frac{3}{16}$ " diameter bead of windshield rubber cement along the top, sides and bottom of each assembly.

27. DOOR OPENINGS

Door openings contribute to water leaks in two ways: First, there may be leaks at the metal joint seams, and, secondly, the roughness of the door opening metal or coach joints may not provide a good sealing contact surface for the door weatherstrip.

Inspect for rough, exposed or unsealed metal joint seams outboard of the door weatherstrip surface. If the seams are shallow, apply body caulking putty to the seam. If the seams are rough, large or deep, metal finish smooth with adjoining surfaces. Apply cold



Fig. 27—Sealing the Plenum Chamber Housing

23-20 BODY SEALING

solder with a spatula or putty knife smoothing it down as much as possible, and let it completely set up. Finish off with a sander and paint.

(Minor Leakage.) Note particularly the metal seam joints and the coach joints at the junction of the floor side sill to floor pan and the "A", "B" and "C" pillars. Water and dust can get through this joint and under the sill scuff plate. It is recommended to seal the full length of the seam and around the coach joints using liquid body sealer, apply it with a dispensing gun.

28. LUGGAGE COMPARTMENT SEALING

Leaks may occur at medallions or clip-holes, tail lamps or the rear quarter panel which will generally appear in the luggage compartment, floor extensions near the quarter panel.

Before attempting to correct the luggage compartment leaks, carefully determine the actual source of the leak.

CAUTION: Do not confuse condensation on metal parts with water leaks.

When the actual source of the leaks has been traced to the luggage compartment itself, correct as follows:

Be sure to obtain the proper fit and alignment of the luggage compartment deck lid before trying to correct the leak at the lid weatherstrip. Inspect the luggage compartment lid drain trough and weatherstrip retainer joints for rough and porous welds. Seal with body caulking putty or body sealer as required. Brush a continuous coating of weatherstrip cement around the entire weatherstrip into the retainer. Be sure to obtain a good fit and compression of the lid weatherstrip. Adjust deck lid if necessary to obtain proper compression. Test with the use of slips of paper or trace powder.

Leaks at the deck lid weatherstrip retainer trough body joints can best be sealed by loosening the

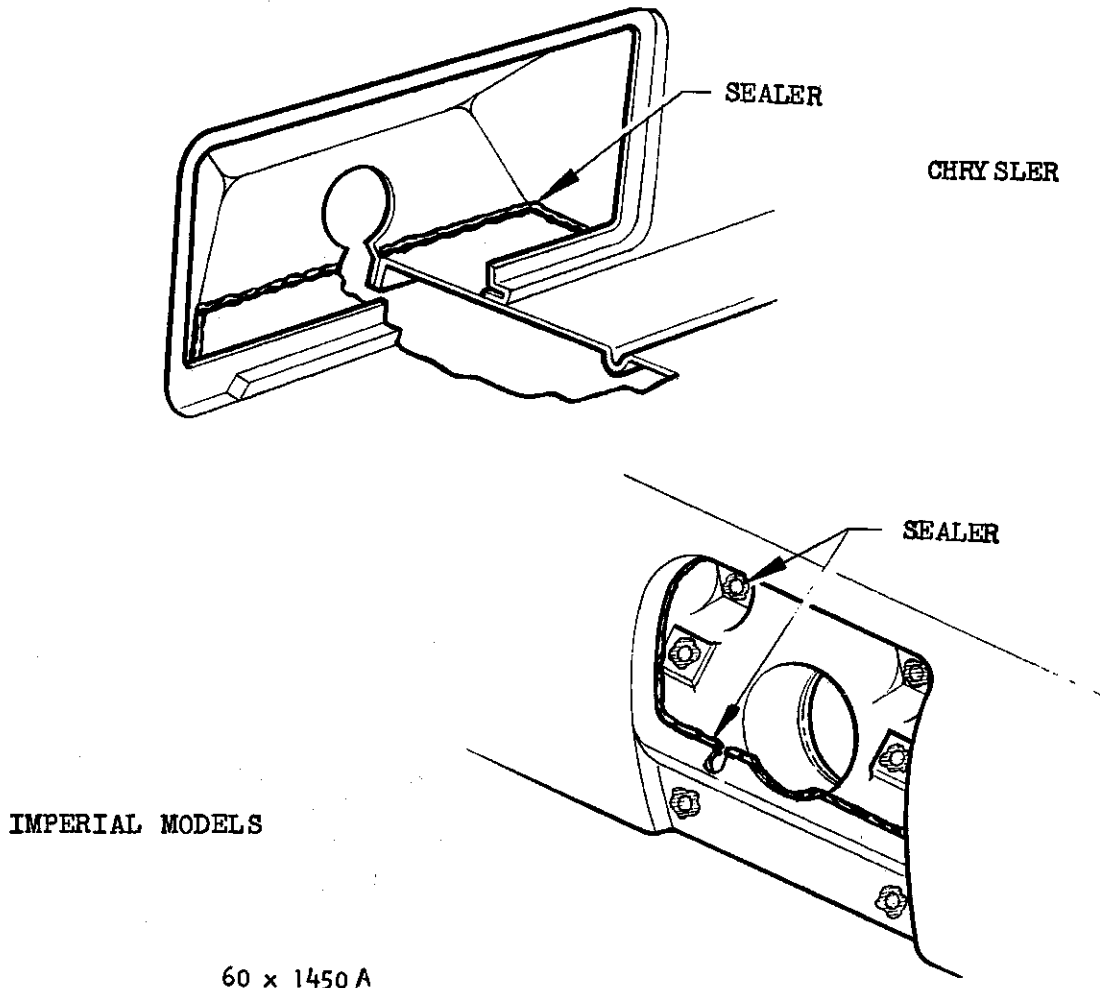

Fig. 28—Sealing the Fuel Filler Housing

weatherstrip at the joint and applying sealer to the entire seam at the inside of the trough and then recement the weatherstrip.

Seal all openings and joint seams on the inside of the luggage compartment lower panel, especially the back-up lamp wire grommets. Seal all luggage compartment floor panel seams with liquid body sealer. Seal between the luggage compartment lower panel and floor panel with black mastic sealer.

29. LEAKAGE AT DECK LID

Before water testing the deck lid make certain that the deck lid is properly fitted. Start the water test at the bottom and work slowly toward the top of each side. Then work across the top of the lid. Inspect the two upper and lower welded joints for proper sealing.

Leakage around the lid is usually caused by insufficient contact between the deck lid and the weatherstrip which may indicate the need for refitting the lid, replacing or shimming the weatherstrip. Clean the surface prior to installation of a new deck lid weatherstrip and brush an even coat of rubber cement to the

weatherstrip cementing surface. Care should be taken not to stretch the weatherstrip during replacement especially at the corners.

NOTE: Reseal the metal weatherstrip retainer joints or burnt spotwelds if required, with body caulking sealer.

30. HOUSING—FUEL FILLER (Fig. 28)

Inspect for pin holes in seam of gas filler housing to deck lower panel (source of gasoline, water, and dust leak into trunk area). Repair seam with gasoline-resistant permagun sealer. To seal, remove attaching screws of fuel filler housing door; apply 1/8" diameter ball of sealer to holes and reinstall the screws.

31. REAR QUARTER PANEL

The increased use of bright metal and medallions on the rear quarter panel results in more clips and bolt holes, which may leak. Leaks from this area will generally appear in the luggage compartment, floor extensions near the quarter panel.

Seal around all attaching clip and bolts holes, tail

CAULKING PUTTY SEALER

IMPERIAL MODELS

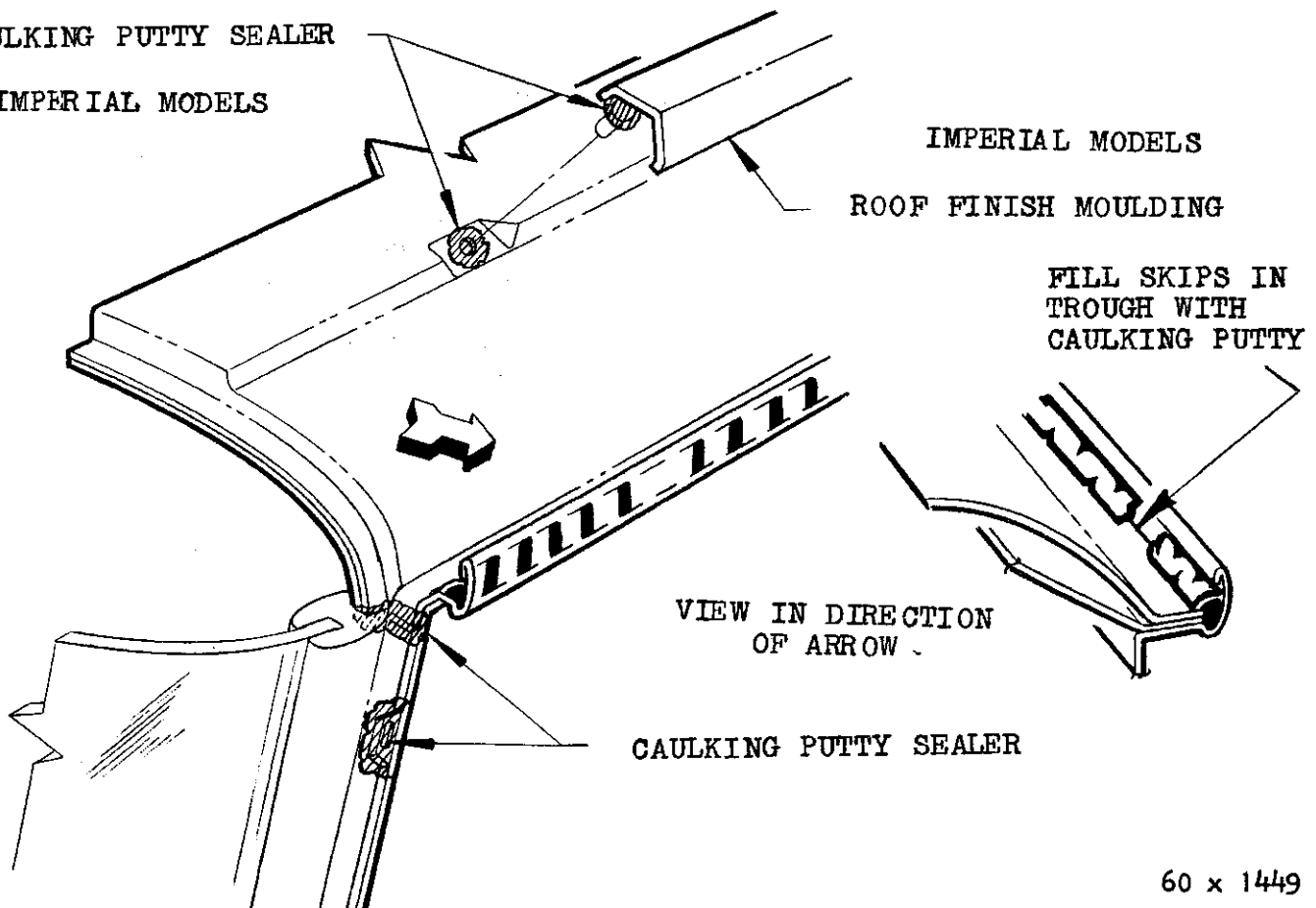
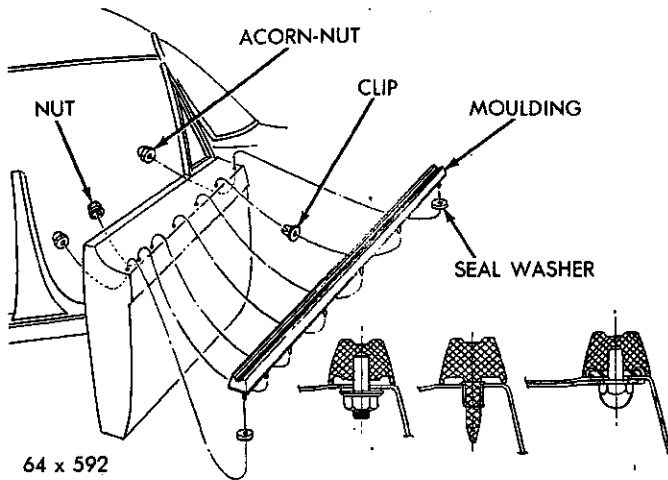

Fig. 29—Sealing Rear Window Glass and Roof Moulding



64 x 592

Fig. 30—Front Door Moulding Attachment (Imperial)

lamp reinforcement seams, and rear quarter panel and floor pan extension with body caulking sealer or windshield cement depending upon the size of the opening at this joint.

32. REAR WINDOW

If water enters the luggage compartment under the package shelf, remove the rear window lower trim moulding and clean out the old sealer from the trough below the weatherstrip. Apply a semi-fluid body caulking putty-type sealer along the entire length of the trough. Seal the trough at both lower corners of the window.

To aid in the installation of the moulding, mark the clip holes by lacing balls of sealer to the rear of each moulding hole. This helps align the trim moulding retaining studs with the holes and avoids the possibility of moving the sealer or damaging the paint.

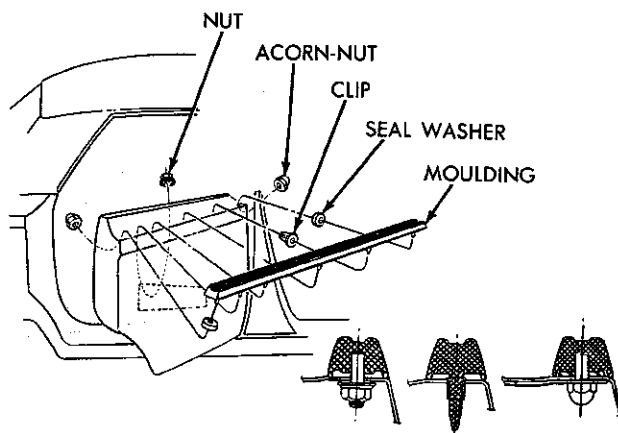

64 x 593

Fig. 31—Rear Door Moulding Attachment (Imperial)

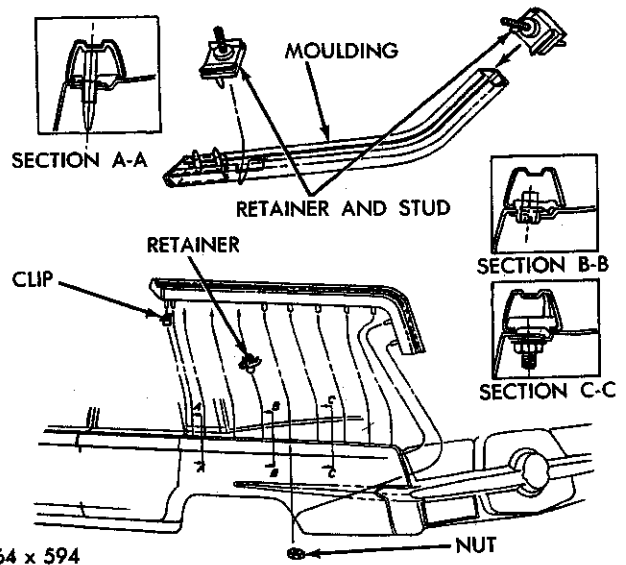

64 x 594

Fig. 32—Quarter Panel Moulding Attachment (Imperial)

33. DECK LID LOCK CYLINDER AND BEZEL

Apply body caulking sealer into the seam of the bezel and deck lid lock. Make sure the sealer is completely around the outer periphery of the bezel.

34. ROOF (Fig. 29)

Inspect the roof drip rails carefully from one end to the other for burned spotwelds, skips or breaks in the seal between the roof flange and the drip rail. Clean the roof drip rail thoroughly before applying the putty caulking sealer. Wipe sealer into areas where skip occurs. Clean off the excess putty. Seal may be painted. It is advisable to inspect the seam joint sealing under the drip rail. Occasionally this seal is incomplete or broken. Use procedure as outlined above for repair.

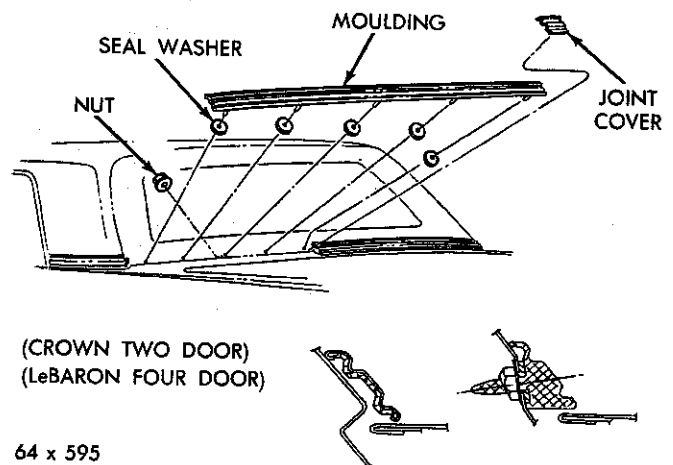

(CROWN TWO DOOR)
(LeBARON FOUR DOOR)

64 x 595

Fig. 33—Deck Opening Upper Moulding Attachment (Imperial)

When correcting a water leak at the front end of the roof, be sure to fill the joint of the roof to the "A" pillar and the slotted notches and skips in the seam in the "A" pillar flange with body caulking sealer. These notches and seams can be seen by removing the windshield pillar mouldings.

On Imperial models, if damage occurs to the headlining due to water and requires replacement, correct the water leakage at the roof trim mouldings.

NOTE: Be sure to remove the trim mouldings and seal around each retaining stud and clip with body caulking putty.

When correcting leaks in the roof panel areas, while the headlining is down, inspect the sealing at the junction of the roof rails, windshield opening header, and windshield pillar (upper "A" pillar). Seal all open body joints with body caulking putty.

35. EXTERIOR MOULDING ATTACHMENT (Figs. 30, 31, 32, 33 and 34)

Exterior mouldings are sometimes a source of water leaks that may be difficult to find. Removing the upholstery trim panels will provide access to the clips and bolts. Usually water stains on the inside panels will indicate the clips or bolts needing to be sealed. Use a soft non-hardening putty type of sealer.

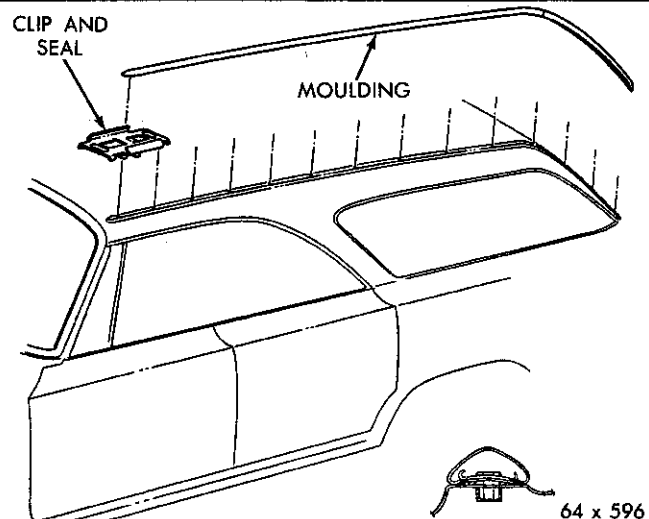

Fig. 34—Roof Top Moulding Attachment (Town and Country)

64 x 596

36. FLOOR PAN LEAKAGE

Road splash can enter the body through any opening in the floor pan seams. Proper sealing can be determined by visual inspection of mud and dust traces inside the body. Properly clean area to be sealed and apply a ball of body caulking sealer to the area, pressing sealer into the seam. Remove floor carpeting and rear seat cushion, if necessary.

PART 4

MINOR BODY SERVICING

37. GRILLE (Imperial Models)

Removal

- (1) Remove the grille to the center support bracket screws.
- (2) Remove the nuts attaching the grille to the front fenders (the nuts are accessible from under the fenders).
- (3) Remove the bolts attaching the grille to the shield.
- (4) Pull the grille straight out to remove.
- (5) Remove the bolts attaching the outer grille sections to the center section.

Installation

- (1) Connect the outer grille sections to the center grille section.
- (2) Position the grille in its opening and install the grille to the stone shield bolts.
- (3) Install the nuts on the grille outer sections retaining studs under the front fenders.
- (4) Install the grille to the center support bracket screws.

38. GRILLE (Chrysler Models)

Removal

- (1) Remove the grille moulding.
- (2) Remove the grille to splash shield bolts.
- (3) Remove the grille to fender tie-bar support bolts.
- (4) Remove the grille assembly.

Installation

- (1) Position the grille in its opening and install the grille to the fender tie-bar support bolts loosely.
- (2) Install the grille to the fender splash shield bolts loosely.
- (3) Align the grille in its opening for correct spacing and tighten all retaining bolts securely.
- (4) Install the grille moulding.

39 DEFLECTOR (Imperial Models)

Removal

- (1) Remove the bumper.

(2) Remove the bolts attaching the grille brackets to the stone shield.

(3) Remove the stone shield to the fender splash shield bolts.

(4) Remove the grille to the support bracket bolts and the screw attaching the shield to the yoke and carefully remove the stone shield.

(4) Remove the grille to the support bracket bolts and the screw attaching the shield to the yoke and carefully remove the stone shield.

Installation

(1) Slide the stone shield into position and install the screws attaching the shield to yoke and the support brackets.

(2) Install the stone shield to the fender splash shield bolts.

(3) Install the grille bracket to the stone shield bolts.

(4) Install the bumper assembly.

40. DEFLECTOR (Chrysler Models)

Removal

- (1) Remove the bumper assembly.
- (2) Remove the grille moulding.
- (3) Remove the stone deflector.

Installation

(1) Position the stone deflector and install the stone deflector to the grille bracket bolts.

(2) Install the grille moulding.

(3) Install the bumper assembly.

41. FENDER

Removal and installation of the front fenders should not present unusual difficulties except that the cowl to fender bracket studs and nuts should be removed to facilitate the removal of the fender assembly.

Removal

- (1) Raise the hood.
 - (2) Tape the leading edge of the front doors and cowl to fender area to avoid damage to the finish.
 - (3) Remove the fender to splash shield, radiator
-

yoke, grille bar, and fender to body attaching bolts.

(4) Remove the outside rear view mirror and antenna lead (if so equipped).

(5) Remove the head lamps, horns, and wires. Remove the fender assembly.

Installation

(1) Install the splash shield, yoke grille body brackets attaching bolts.

(2) Install the head lamp, horn and antenna and outside mirror (if so equipped).

(3) Install the cowl quarter to fender bracket studs and nuts.

(4) Install the head lamp wires.

(5) Adjust the hood to fender and the fender to door alignment.

42. RADIATOR CORE SUPPORT

The radiator core support is the basic foundation for all front end sheet metal. In the case of an accident, it is best to replace the support if there is indication of sheet metal misalignment.

Removal

(1) Drain the radiator, remove the radiator hoses and remove the radiator core attaching screws. Remove the radiator from the engine compartment.

(2) Remove the hood lock striker bar.

(3) Remove the horn and headlight wiring from the core support.

(4) From under the fenders remove the fender side shield to core support attaching screws.

(5) Remove the core support to frame attaching screws.

(6) Remove the radiator core support up out of the engine compartment.

Installation

(1) Position the radiator core support down into the engine compartment. Install the frame to core support attaching screws finger tight.

(2) From under the fenders install the fender side shield to core support attaching screws only finger tight.

(3) Attach the horn and light wires to the core support with the plastic straps.

(4) When all attaching screws have been installed, tighten them progressively to their specified torque readings.

(5) Install the radiator core, radiator hoses and fill the radiator.

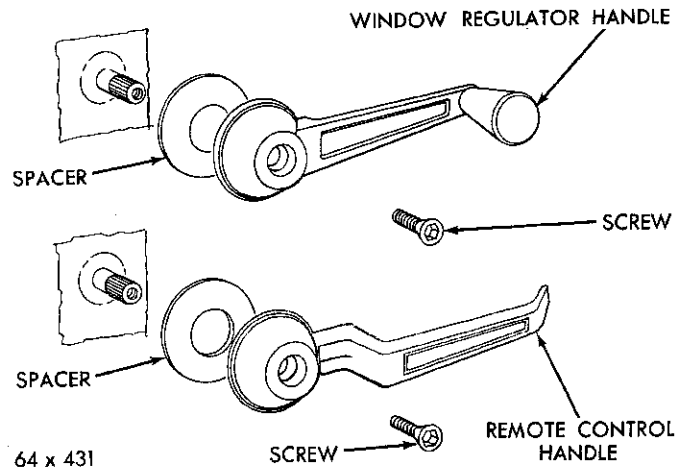

Fig. 35—Inside Handle Attachment (Chrysler)

43. DOOR AND QUARTER PANEL TRIM REPLACEMENT

Inside Handle Removal (Imperial)

The inside handles are retained on the remote control shaft by a screw and clamp. To remove the handle remove the two arm rest well attaching screws and elevate the rear of the well. Loosen the handle attaching screw and work the handle out and off of the shaft as the upholstery panel is held out from the door frame.

Inside Handle Removal (Chrysler) (Fig. 35)

The remove control and window regulator handles are attached by an Allen set screw located in the center of the large end of the handle. The shaft and handle are splined to permit different handle locations.

44. DOOR AND QUARTER TRIM PANELS REMOVAL

The trim panels are retained to the door and body by spring clips attached to the trim panels and snapped into matching holes in the door or body inner panels. The panels are removed by inserting a screw driver or suitable tool between the trim panel and the door and body panel and then prying the clips out.

45. ELECTRIC WINDOW REGULATOR SWITCH REMOVAL

The window regulator switch is retained in the upholstery panel by a spring clip attached to the switch housing on the inside of the trim panel. Remove the trim panel and disconnect the wires from the switch. Remove the retaining clip from the switch housing and remove the switch from the trim panel.

46. DOOR OPENING WEATHERSEAL

Removal

- (1) Remove the step plate attaching screws and remove the step plate from the sill of the door opening.
- (2) Grasp one end of the weatherseal assembly and pull the weatherseal and windlacing assembly up and off of the fence or door opening flange.
- (3) Continue the full distance around the door opening.

Installation

- (1) Press one end of the weatherseal and windlacing over the fence or flange in the center of the door sill.
- (2) Progressively work the assembly onto the fence or flange by lightly tapping it into place with a block of wood or soft faced hammer.
- (3) Butt the two ends of the weatherseal together and install the step plate and attaching screws.

47. HEADLINING

Removal (All Models Except Hardtops and Convertibles)

- (1) Remove the dome light assembly and rear seat back and cushion assembly as well as the sun visor and the upper windshield garnish moulding.
- (2) Pull the rear window weatherstrip out at the top and down the side of the rear window opening.
- (3) Pull the headlining out from under the rear package shelf and away from the rear quarter panel and wheel housing.
- (4) Pry the headlining retainer strip, with a screw driver, away from the roof rail above the doors (The headlining is cemented in place over the windshield header and at the rear window body opening). To

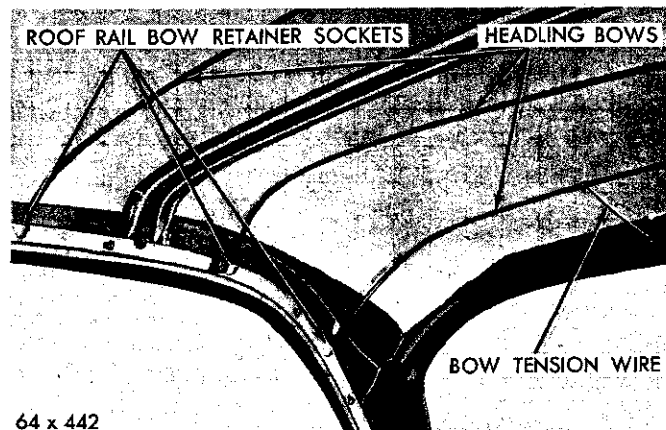

64 x 442

Fig. 36—Roof Rail Bows

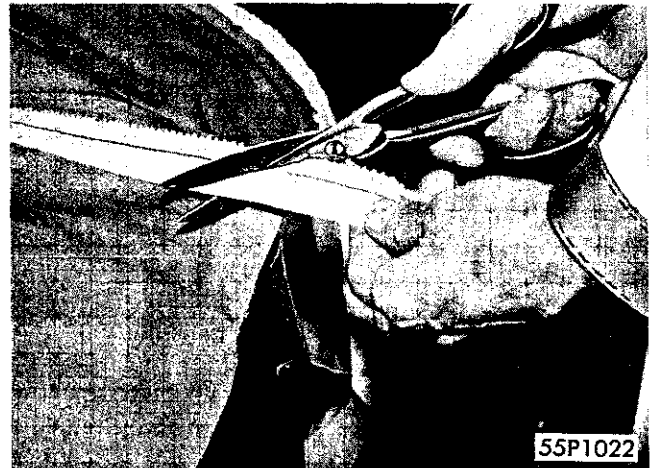

55P1022

Fig. 37—Trimming Excess Listings

remove the lining remove the cemented front and rear sections of the headlining from the windshield and rear window openings before removing the headlining and bows from the roof rails.

NOTE: The roof rails on all models using cloth headlining are strung through retaining loops sewed into the lining. Each bow is held in place by an attaching loop pressed into each roof rail and sprung in place when installed to keep the headliner taut (Fig. 36).

(5) After pulling the headlining from the windshield and rear window opening, remove the headlining bows from the roof rail retainers. Use care not to damage the lining.

(6) Remove the bow retaining springs and remove the headlining from the roof, the rear quarter and the lower section under the package shelf.

Installation

- (1) Remove each bow from the old listing.

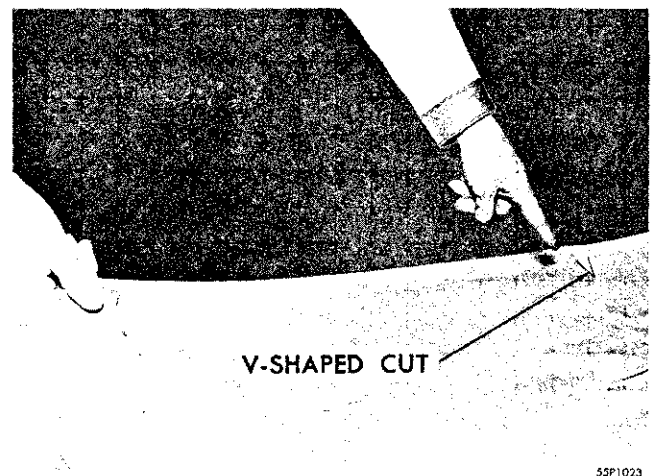

V-SHAPED CUT

55P1023

Fig. 38—Marking the Center of Headlining

NOTE: Before installing the bows in the new headlining, trim the excess listing even with the edges of the headlining, as shown in Figure 37.

(2) Notch the headlining at the front and rear ends to indicate the center of the material by making small V-shaped cuts, as shown in Figure 38. Use these marks as guides to properly center the headlining.

(3) Starting at the rear of the vehicle apply cement to the window opening. Install the rear bow tension spring.

(4) Install the bows in the correct location, since bows are of different length and must be correctly positioned to prevent the headlining from wrinkling. This procedure assures correct installation of the bows.

(5) Install the remaining bows, making sure to stretch the headlining evenly so that approximately the same amount of material hangs down on each side.

(6) Apply cement to the windshield header bar (Fig. 39). Wait until it becomes tacky. Stretch the headlining forward and over the cemented area, and onto the barbs on the windshield header. Make sure the first seam of the headlining is straight.

(7) Cut holes in the headlining for the visor (Fig. 40) retaining screws and pivot.

(8) Install the visors before tucking in the corners of the headlining at the top of the windshield posts to prevent tearing the headlining when tightening the screws.

(9) Install the garnish mouldings.

NOTE: In most cases the listing is longer than necessary. Cut the material at the ends to prevent wrinkling at the seams when it is tucked or cemented

Visor Attaching Screw Holes

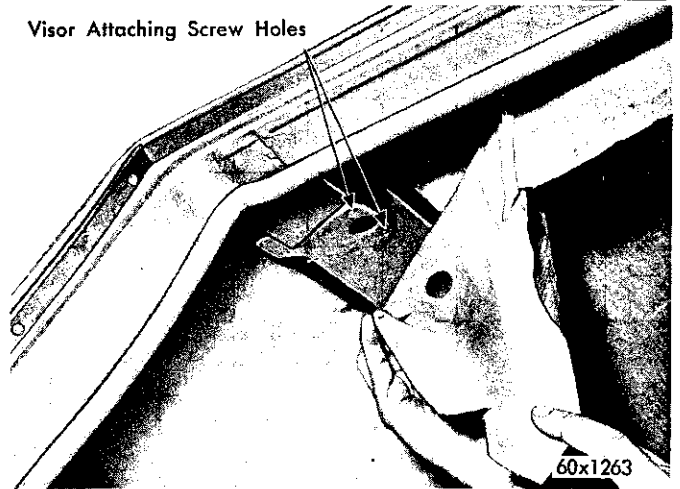

Fig. 40—Visor Attaching Points

in place. Cut the listing from the end up to the clip. Use care to prevent cutting the listing too far up the bow and ruining the fit of the headlining.

(10) After listings are cut, start at the front and trim the headlining so that only ½ to 1 inch of material hangs down below the door windcord.

(11) Use a dull putty knife to tuck the first and second seam between the roof side rail and retainer, as shown in Figure 41. Tuck the remaining material in place around the rear window opening and lower package shelf.

(12) When one man is performing the installation, alternate from one side to the other, completing one section at a time; make certain that the seams are straight. As the work progresses, the material should be kept free of wrinkles until all of the headlining is tucked in place between the roof rail and the retainer.

(13) Install the rear window glass moulding dome light, side and the upper windshield mouldings.

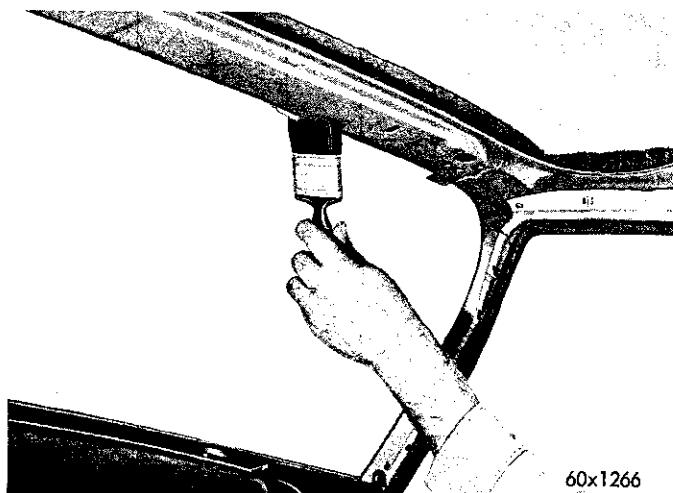

Fig. 39—Applying Cement to Windshield Header Bar



Fig. 41—Installing Headlining at Roof Rail

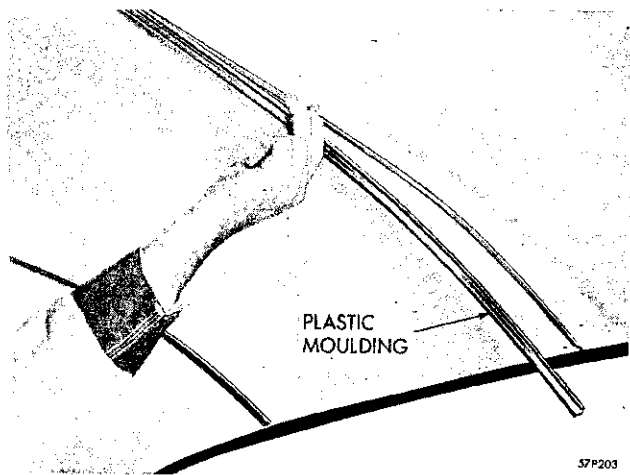

Fig. 42—Removing Plastic Mouldings

(14) Install the rear package shelf and rear seat back and cushion.

(15) Seal and inspect the rear window glass for leaks.

Hardtop Models (Plastic Mouldings)

If either of the outer sections are to be replaced it is only necessary to remove one plastic moulding (See Fig. 42). If the center section is to be replaced it will be necessary to remove both plastic mouldings from the retainers, as shown in Figure 43.

Removal

- (1) Remove the front and rear window garnish mouldings.
- (2) Starting at either end, pry the plastic moulding off of the retainer.

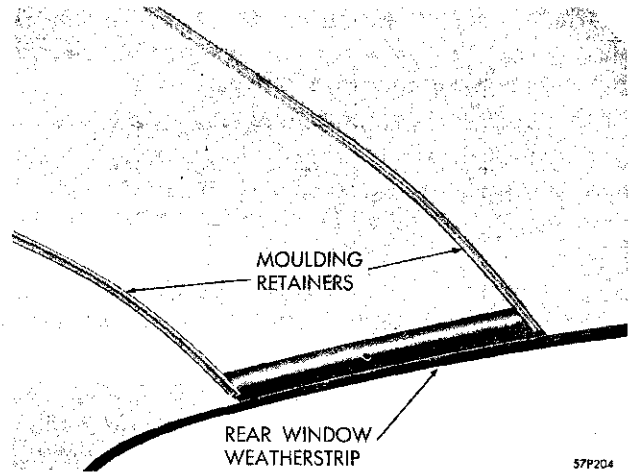

Fig. 43—Plastic Mouldings Removed

(3) Pull down on the moulding to release it from the retainer.

(4) Remove the damaged section by pulling it downward to release it from the retainer.

(5) To remove the plastic headlining at the side pull towards the center of the vehicle and this will release the plastic headlining from the small spring-type clips at the outer edges.

Installation

- (1) Push the plastic headlining onto the small retainer clips on each side of the vehicle.
- (2) Push the headlining up at the center and properly center the moulding and snap in into place.
- (3) If the center section is to be installed push it into place on the retainers and snap ring.
- (4) Snap the mouldings onto the retainers and install the garnish mouldings.

SEATS

48. CUSTOM POSITIONED SIX-WAY MANUAL FRONT SEAT ADJUSTMENT (Fig. 44)

- (1) Loosen the four adjusting bolts (two in each seat base).
- (2) The horizontal slots allow a fore or aft movement of 1 5/8 inches.
- (3) The vertical slots allow up, down or tilt movement of 1 1/8 inches.
- (4) Position the seat as desired and tighten the bolts to lock it in place.

49. FRONT SEAT

Removal

- (1) The front seat cushion is an integral part of the seat frame. From under the vehicle remove the 4 nuts attaching the seat base to the floor pan.
- (2) Remove the seat and base assembly.

Installation

- (1) Place the seat and base assembly on the floor pan so that the studs in the seat base line up with the holes in the floor pan.
- (2) Install the 4 attaching nuts and tighten securely.

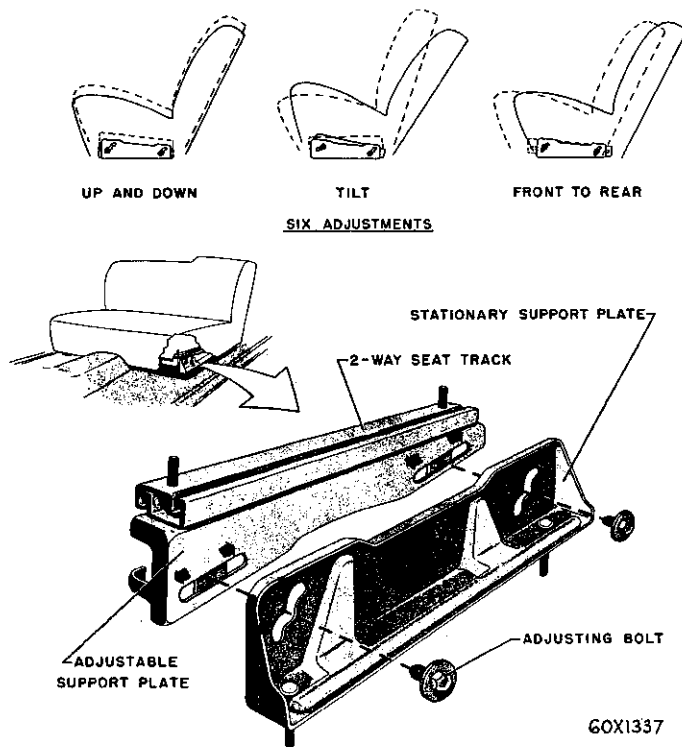

Fig. 44—Six Way Slotted Seat Track Assembly

50. REAR SEAT

The rear seat cushion is held in place by inserting the rear edge of the seat cushion under the lower edge of the seat back. The front lower frame of the seat engages into a slotted bracket welded to the floor pan.

Removal

(1) At the base of the seat frame midway from the floor pan tunnel and the end of the seat, press firmly

toward the rear of the vehicle and disengage the seat frame from the hold down brackets.

(2) Raise the front of the seat up and withdraw it from under the seat back.

51. REAR SEAT BACK

The rear seat back is held in place by two tangs of the upper edge of the seat frame being inserted into slots in the package shelf. The lower edge of the seat back is held in place by two metal strips of the floor pan being bent over the lower edge of the seat back frame.

Removal

(1) With the seat cushion removed, bend up the two metal retaining strips at the lower edge of the seat back frame.

(2) Raise the seat back straight up and disengage the tangs from the package shelf and remove the seat back from the car.

52. EXTERIOR MOULDINGS

Exterior mouldings are held in place by numerous clips, "T" bolts, brackets and by a new plastic retainer. This is a button type retainer with expanding legs that extend through holes in the sheet metal. These are expanded by forcing a tapered pin through the retainer and expanding the inner part of the retainer. The moulding is then snapped over the outer flange of the retainer. The mouldings may be pried off the retainer for replacement.

Reference to (Figs. 30, 31, 32, 33 and 34) will show the type and location of retainers and clips used to hold the various mouldings in place.

DOORS, DECK LID, TAIL GATE AND HARDWARE (All Models)

53. FRONT DOOR

Removal

(1) With the door in the open position, place a jack, with a block of wood or pad on the lifting plate of the jack, as near the hinge as possible (This will hold the weight of the door as the hinge bolts are loosened).

(2) Remove the inside handles, trim panel and weather shield.

(3) Scribe a line around the upper and lower hinge plates on the "A" post and also on the door panel.

(4) Remove the hinge attaching screws from the "A" post and remove the door for further disassembly.

NOTE: On vehicles with electric windows, disconnect the battery and disconnect the wires from the window regulator motor and remove them from the door assembly.

Installation

(1) With the door inner hardware installed and the hinges attached to the door panel, place the door in position in the door opening, supported by a padded jack.

(2) Locate the door hinge plates on the body "A" post and install the hinge attaching screws only finger tight.

(3) Adjust the jack to align the hinge plate scribe marks on the "A" post and tighten the attaching screws.

(4) Complete the door aligning procedure and install the weather shield, trim panel and inside handles.

NOTE: Prior to this installation, on electric window lifts, install the wiring in the doors and attach to the motor and control switch.

54. REAR DOOR (All Models)

Removal (4 Door Sedan)

(1) Open the rear door and place a padded jack under the door near the hinges.

(2) Remove the inside handles and door lock remote lever, upholstery trim panel and weather shield.

(3) Scribe aligning marks around the hinge plates on the "B" post and on the door frame.

(4) Remove the hinge attaching screws from the "B" post and remove the door from the body.

NOTE: On vehicles with electric window lifts disconnect the battery and disconnect the wires from the motor and control switch and remove them from the door prior to door removal.

Installation

(1) With the rear door inner hardware installed and the hinges attached to the door panel, place the door in position in the door opening.

(2) Place the hinge plates in location on the "B" post and install the attaching bolts finger tight.

(3) Support the door on a padded jack and align the hinges with the scribe marks.

(4) Tighten the attaching screws and test the door for alignment.

(5) Install the weather shield, trim panel and inside handles.

NOTE: On vehicles with electric window lifts, insert the wiring into the door and attach the wiring to the motor and control switch prior to the installation of the trim panel. Reconnect the battery cable.

(6) Open and close the door several times and inspect the alignment.

Removal (4 Door Hardtop Rear)

(1) Open the door and support it on a padded jack placed near the hinges.

(2) Remove the "B" post trim panel and scribe aligning marks around the hinges.

(3) Remove the door inside handles, remote lock lever, upholstery trim panel and the weathershield.

(4) Scribe aligning marks around the hinges on the door panel and remove the hinge attaching screws from the "B" post.

(5) Remove the door from the vehicle.

NOTE: On vehicles with electric window lifts, disconnect the battery and remove the wires from the motor and withdraw from the door panel prior to the door removal.

Installation

(1) With the rear door inside hardware installed in the door and the hinges attached, place the door assembly in the body opening.

(2) Support the door on a padded jack and align the hinges with the scribe marks in the "B" post.

(3) Install and tighten the hinge attaching screws.

(4) On vehicles with electric window lifts insert the wires into the door and attach the motor and control switch.

(5) Install the weathershield, trim panel, inside handles and remote lock lever.

(6) Open and close the door several times and inspect the alignment.

55. DOOR HINGES (All Models)

The door hinge replacement should be followed as suggested in the door replacement section of this manual.

56. DOOR INSIDE HARWARE AND TRIM (Manual Door Locks)

Removal

(1) On the Chrysler Newport and 300 models with

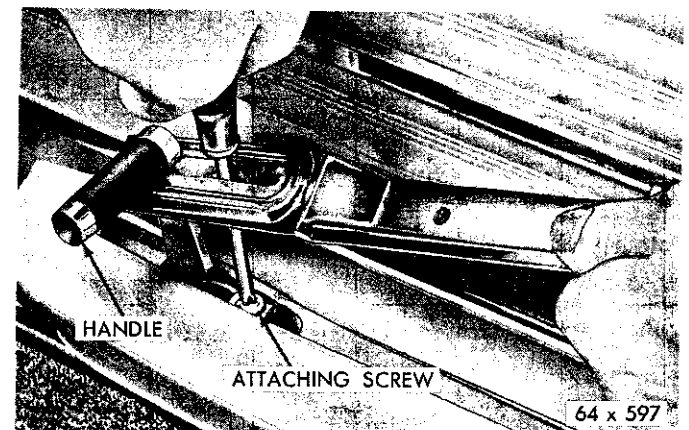

Fig. 45—Inside Door Handle Attachment (Imperial)

the handles behind the arm rest, remove the arm rest to reach the remote control handle attaching screw.

(2) On Imperials or Chrysler New Yorker models use a long screw driver to reach through the handle slot and loosen the handle clamping screw which is directly in the rear of the handle (Fig. 45).

(3) After loosening, the handle may be pulled off the shaft as the trim panel is removed.

(4) The rear door locking control knob is attached to its shaft on all models by means of a small screw through the center of the hub into the center of the end of the shaft. The knob is positioned on the shaft by spline teeth on the O.D. of the shaft and the I.D. of the hole in the knob.

Installation

(1) On all models, position the locking control knob on the splined shaft.

(2) Insert the small screw through the center of the hub into the center end of shaft.

(3) On the Chrysler Newport and 300 models, install the arm rest if removed.

(4) On Imperials and New Yorker models, replace the trim. The handle can be replaced with the trim.

(5) Using a long screw driver tighten the handle clamping screw which is directly in front of the handle.

57. DOOR LOCK AND REMOTE CONTROL ASSEMBLIES

Front Doors, All Models Except Hardtop—Removal

(1) Remove the door inside hardware and trim and disconnect the outside handle control links.

(2) Remove the glass run felt channel.

(3) Starting at the top end of the division bar and working rearward pull the channel down and out of its retaining channel all the way to the glass at the lock face of the door then pull straight up so the channel will slide out from between the glass and the lower channel.

(4) If the glass fits tight, loosen the glass guide channel extension (lower extension of division bar) at its bottom attachment to allow the glass to move forward.

(5) With the felt channel removed pull up the metal that retains the felt channel below the window opening.

(6) Carefully raise the glass, by means of the regulator crank, being sure the glass follows in the channel from which the felt channel was removed.

(7) With the glass in this position, disconnect the outside handle link at the lock, and the key cylinder link at the lock.

(8) Remove the two screws attaching the remote control assembly to the door inner panel and the four screws holding the lock to the door shut face.

(9) Slide the lock out of the hole in shut face of the door and rotate the lock to disconnect the remote control link at the lock. Remove both lock and remote control from the large opening in the door inner panel.

Installation

NOTE: Lubricate all pivots on the linkage as they are assembled.

(1) Insert the lock and remote control into the door.

(2) Connect the remote control link to the lock.

(3) Slide the lock into the hole in the shut face of the door.

(4) Install the four screws that hold the lock to the door shut face.

(5) Install the two screws that attach the remote control assembly to the door inner panel.

(6) Connect the key cylinder link to the lock.

(7) Connect the outside handle link to the lock.

(8) When reinstalling the metal glass run channel (with glass lowered) be sure it is retained in the clip at the bottom bracket and that the top clip hooks into the slot provided.

(9) After this channel is secure, push the felt channel down the edge of the glass into the metal channel, being sure it goes back of the lower clip. Soap solution added to the glass run will ease installation. (**Never use oil.**)

(10) Press the upper part of the felt channel into the proper location, up the side and along the top of the door window opening.

(11) Be sure to adjust the glass fit between the channels by moving the adjustment of the bottom end of the division bar so the glass cannot get out of the channels yet is not binding between them.

(12) Install the trim.

All Rear Doors and Front Hardtop Doors

Raise the glass to the top position and remove the lock and remote control screws (rear door—also take the nut off the locking lever assembly) and remove the assemblies from the panel. Rotate the bottom of the lock forward to disconnect the remote and lock control links (Fig. 46). Take the lock out of the door. On Imperial front doors, it is easier to get

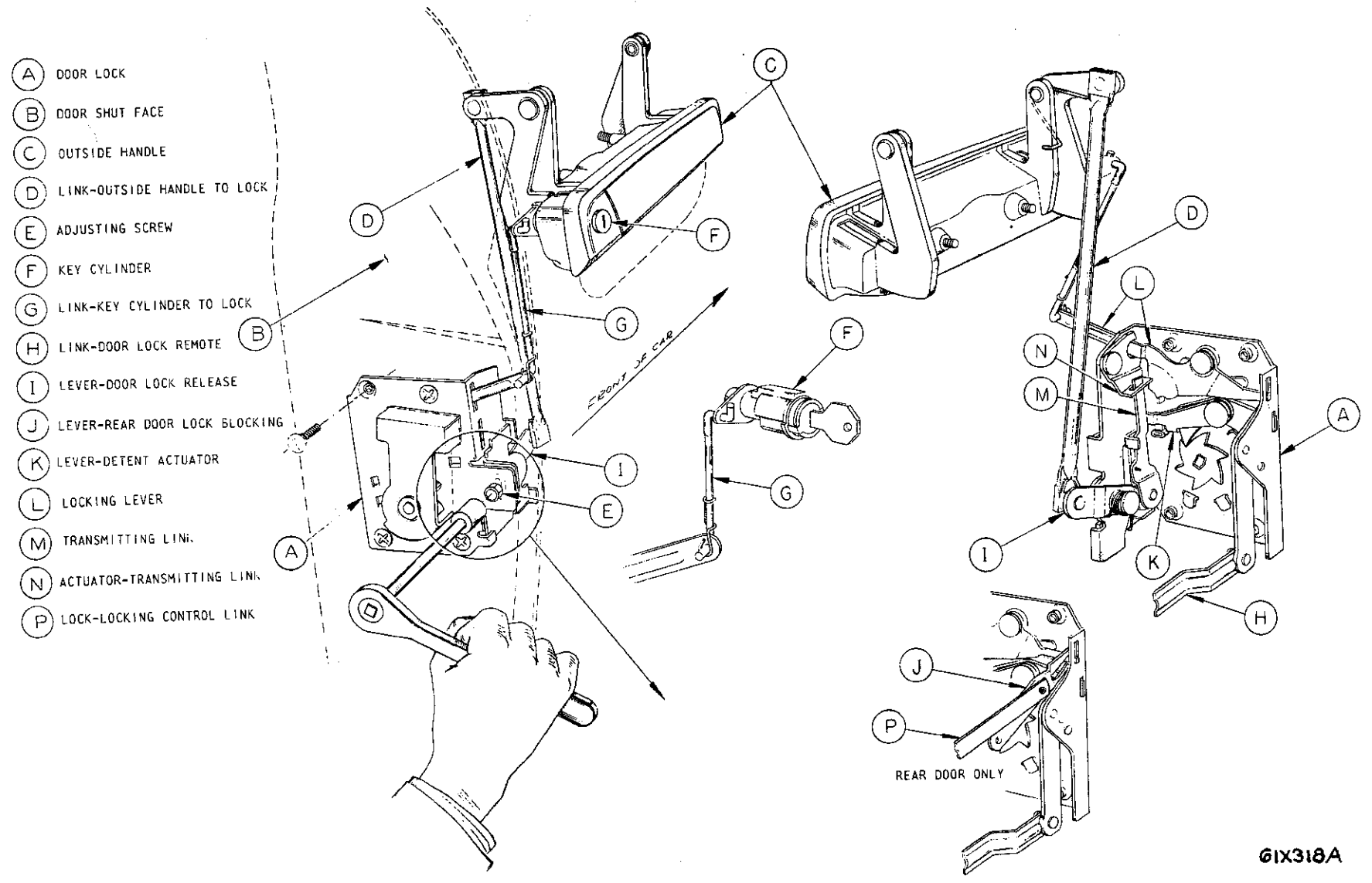

Fig. 46—Manual Door Lock and Linkage

the remote control disconnected from the lock if the glass rear lower guide channel bottom attaching screw nut is removed and the channel pushed away from the inside panel so that the lock remote control link can be freed from back of the channel.

Front and Rear Doors On Imperial Sedans

The extruded aluminum upper window frame must be removed before the lock can be taken out of both front and rear doors.

This is accomplished by removing bolts attaching the upper aluminum frame to door.

58. OUTSIDE DOOR HANDLE AND KEY CYLINDER (Fig. 46)

Removal (Imperial)

- (1) Remove the inside hardware and trim.
- (2) Run the window glass up to the top position.
- (3) Disconnect link (D) from the handle to lock by pulling away from lock release lever (I). The link clip will snap off over the ball on which the link pivots. On the front door only disconnect the link from the key cylinder (F) to the lock (G) by removing the formed wire clip from the rod and removing the rod from the lock lever (L).
- (4) Back off the two nuts on the studs at the back of the handle. Pull the handle out of the door.
- (5) To remove the lock cylinder (with or without removing outside handle) take out the cylinder retaining screw at the back of the cylinder and pull the cylinder out of the handle.

Installation

- (1) Install the lock cylinder (F) in position, install the link rod (G) and the wire clip.
- (2) Install and tighten the cylinder retaining screw.
- (3) Insert the handle in the door, install the two stud nuts on the back of the handle.
- (4) Install the wire clip on the rod (D) and snap the rod over ball on which the link pivots.
- (5) Install the trim and hardware.

Removal (Chrysler)

- (1) Remove the inside handles, trim panel and weather shield.
- (2) Through the access hole in the inner door panel unsnap the door lock link from the ball of the outside handle.
- (3) Remove the nut and washer from the grip end of the handle and the screw and washer from the button end of the outside door handle.

CAUTION: Be careful not to lose the gaskets used under the ends of the handle.

Installation

- (1) Place the gaskets on the ends of the door handle and hold the handle in place on the outside door panel.
- (2) Install the attaching nut and washer and the screw and washer in the ends of the handle.
- (3) Snap the socket of the link onto the ball of the push button.
- (4) Install the weathershield, trim panel and inside handles.

59. LOCK CYLINDER (Fig. 47)

Removal

- (1) Remove the inside handles, trim panel and weathershield.
- (2) Using a screwdriver through the access hole of the door inner panel pry the "U" shaped retainer off of the back of the lock cylinder.
- (3) Withdraw the lock cylinder part way out of the door panel and with a rotating motion of the lock cylinder body, disengage the lock cylinder arm from the link.

Installation

- (1) Hold the lock cylinder link in alignment with the lock cylinder hole in the door outer panel.
- (2) Engage the hole of the lock cylinder arm with the link and rotate the lock cylinder until the link is locked in place.
- (3) Enter the lock cylinder into place and install the "U" shaped retainer into the grooves of the lock cylinder.
- (4) Install the weather shield, trim panel and inside handles.

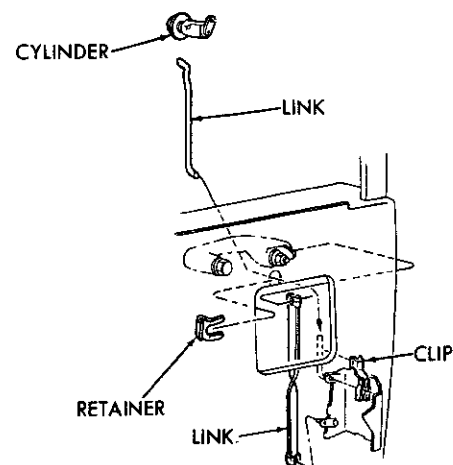

63 x 740

Fig. 47—Door Lock and Lock Cylinder

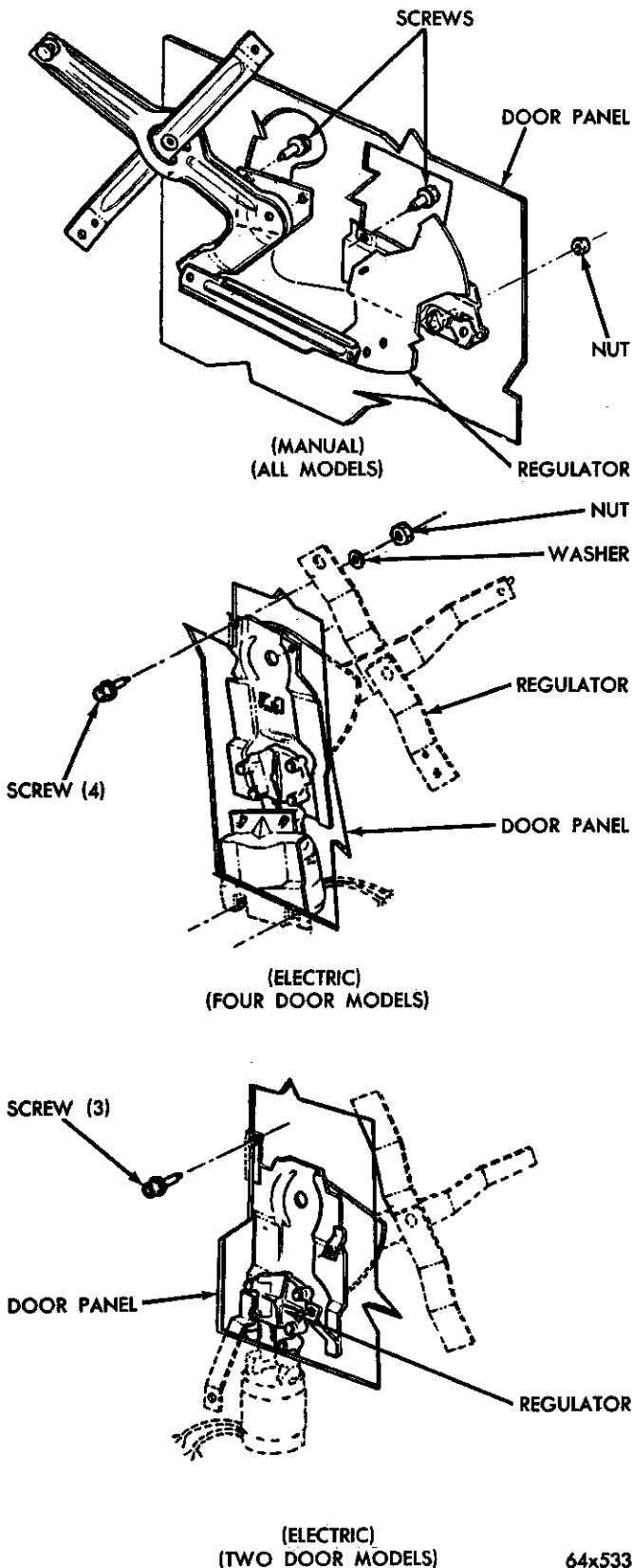

Fig. 48—Front Door Window Regulators (Chrysler)

60. FRONT AND REAR DOOR WINDOW REGULATOR (Figs. 48, 49 and 50)

Removal

- (1) Remove the garnish moulding, arm rest and remote control handles.
- (2) Remove the trim panel and water shield.
- (3) Raise the door glass and remove glass from regulator.
- (4) Remove the regulator attaching screws and remove the regulator and pivot links through the door opening.

Installation

- (1) Install the pivot link and regulator assembly.
- (2) After installing the regulator, turn the handle so the arm is in the raised position.
- (3) Engage the regulator arm in the door glass lower channel. Lower the glass and install regulator arm retainer and clips.
- (4) Install the water shield trim panel and inside door hardware.
- (5) Install the garnish moulding.

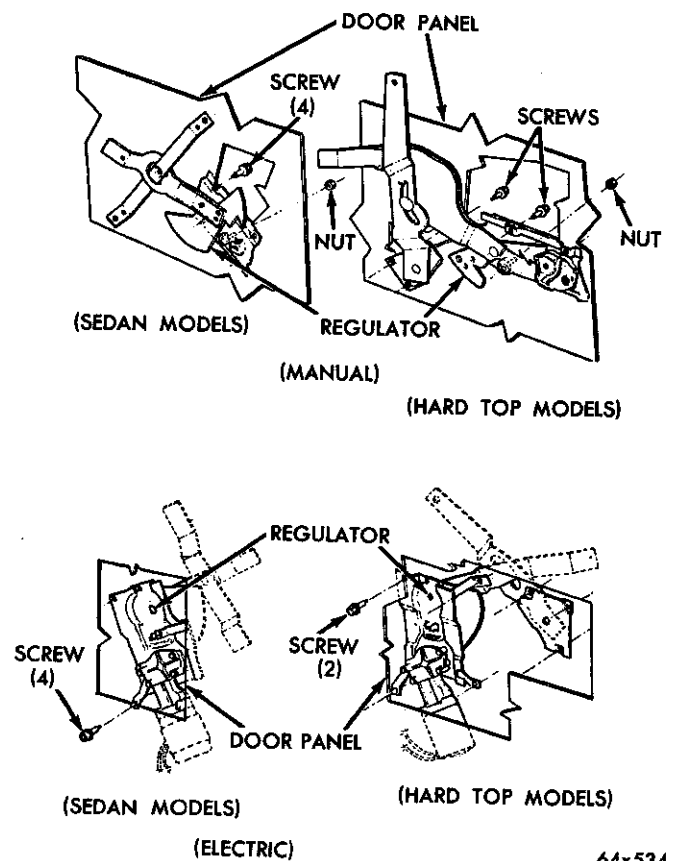

Fig. 49—Rear Door Window Regulator (Chrysler)

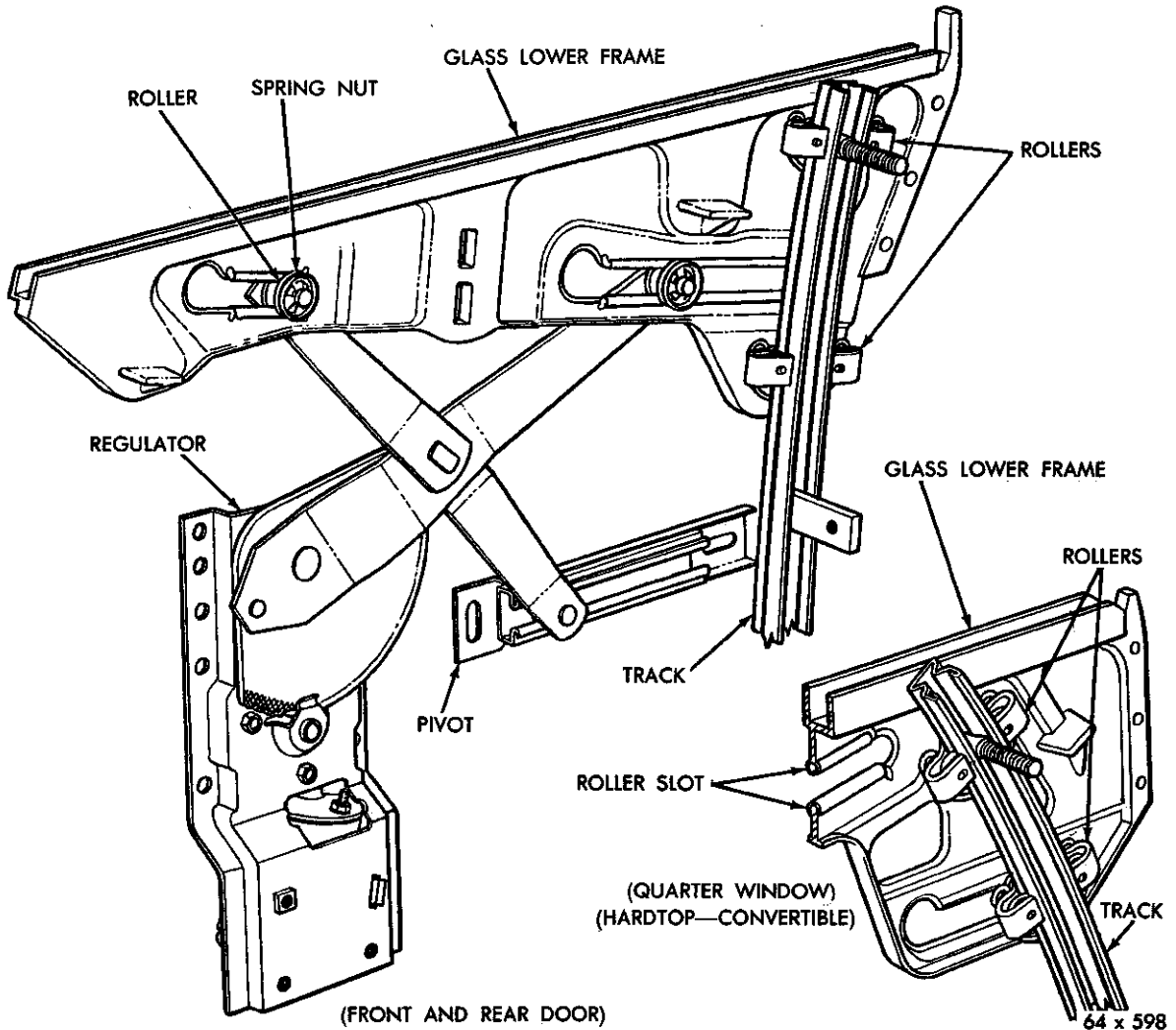

Fig. 50—Window Regulator (Imperial)

61. REAR DECK LID, HINGES AND LOCKS—Removal, Installation

Alignment

The weight of the lid is counterbalanced in all positions by the tension of two torsion bars (See Figure 51). The torsion bars are long, small diameter steel bars, that are free at one end and anchored to support the bracket at the other. A roller sleeve on the free end, operates against a "cam contour" on the back face of the hinge. As the deck lid is raised, the action of the rollers against the hinges cause the bars to twist, exerting a torsional resistance that balances the lid. To permit adjustment of the torsion bar tension, four slots are located in each support plate.

62. REAR DECK LID (Convertible)

On convertible models, the weight of the rear deck lid is counterbalanced by the use of coil springs

(Figure 52). Vertical and lateral adjustments of the deck lid are accomplished through the use of elongated bolt holes in the hinge brackets.

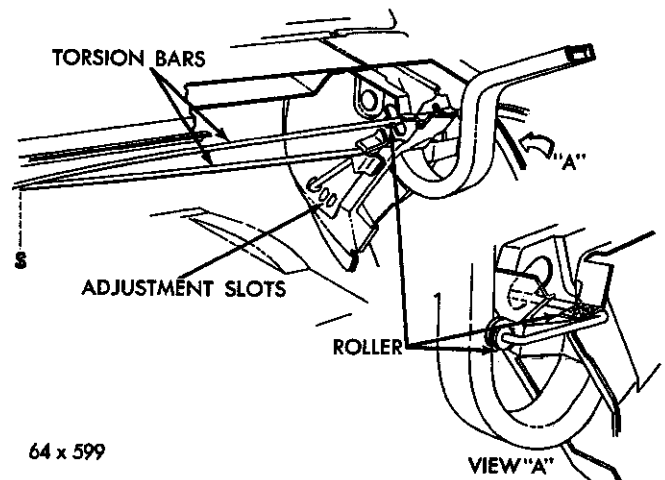

Fig. 51—Deck Lid Hinge (Imperial)

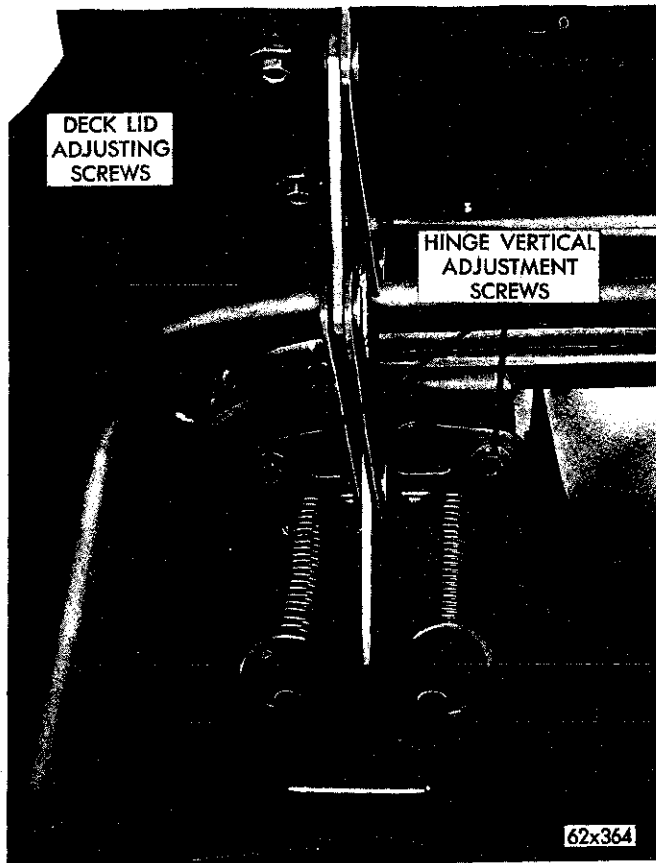

Fig. 52—Deck Lid Hinge (Convertible)

63. DECK LID

Removal

Adjustment of the deck lid is obtained by loosening the bolts and shifting the lid from side to side or front to rear. It is often possible, however, to properly fit deck lid by adjusting the striker plate, latch or both. Should it become necessary to remove the deck lid for replacement or repair, refer to Figure 11.

(1) Raise the deck lid remove one of the two bolts in each hinge that attach the lid to the hinge arm (Leave the remaining two bolts finger loose).

(2) Brace the deck lid in such a hammer so as to hold the lid in position while removing the last two bolts (This will keep the lid from sliding down and damaging the rear deck).

(3) Remove the last two bolts and lift the deck lid up and away from rear of the vehicle.

Installation

(1) Lift the lid and slide down into position. Install the attaching bolts. Do not tighten them, just snug down.

(2) Lower the lid and check fit.

(3) If necessary adjust lid, test the adjustment of the latch and striker plate.

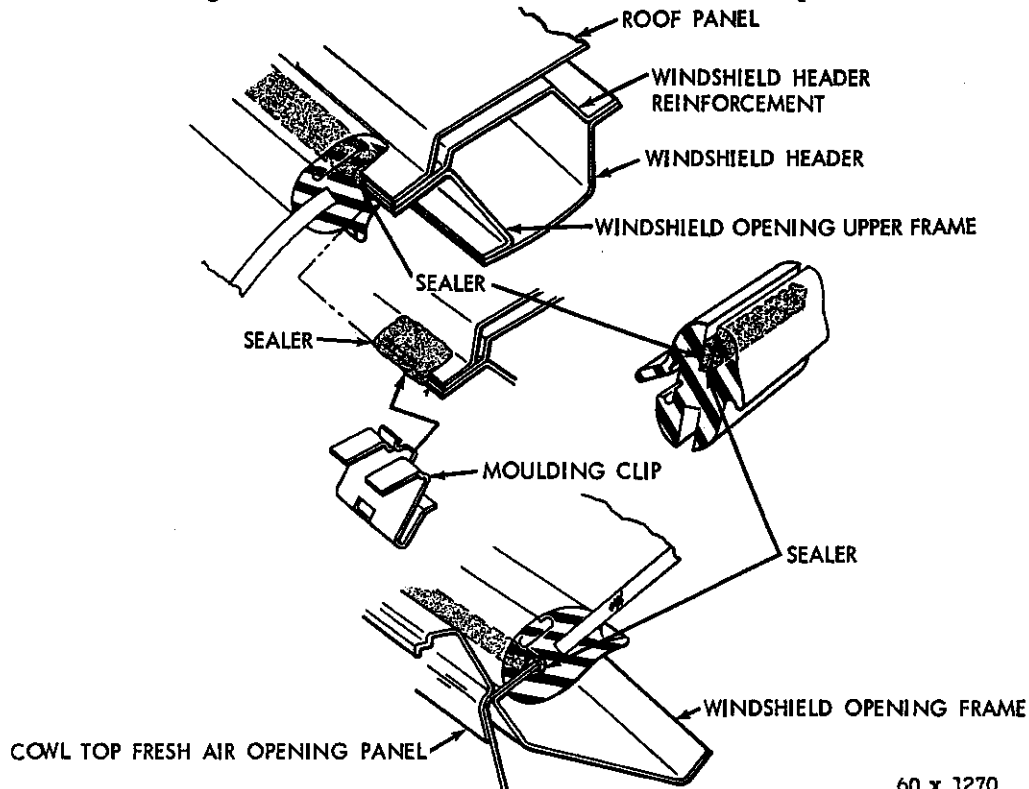

Fig. 53—Windshield Weatherstrip Cowl and Roof Panel Sealing

60 x 1270

64. DECK LID HINGES (Fig. 51)

Removal

The deck lid hinge upper mounting flange is fastened to the deck lid by two bolts at each hinge. The bolt holes are slotted and slightly oversize to permit fore-and-aft adjustment of the deck lid.

- (1) Raise the deck lid and brace the lid on the corner where the hinge is to be removed.
- (2) Remove the torsion bar from the side the hinge is to be removed.
- (3) Remove the bolts that hold the deck lid to the hinge arm.
- (4) Remove the spring nut from the hinge pivot.
- (5) Disengage the hinge from the pivot and remove the hinge from the rear compartment.

Installation

- (1) Slide the hinge into position in trunk rear compartment. Install the spring nut on the pivot.
- (2) Install the bolts that hold the hinge to the deck lid. Do not tighten, just snug down.
- (3) Remove the prop and lower the lid and inspect the fit.
- (4) Make the necessary adjustments. Test the adjustment of the latch and striker. After adjustments have been made, prop the lid open and install the torsion bar.

65. WINDSHIELD GLASS—(All Models)

The windshield and rear window weatherstrip are

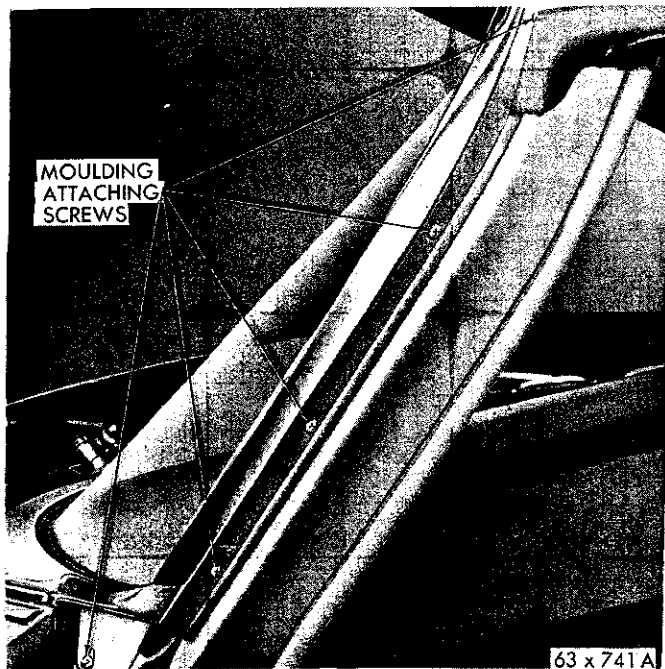

Fig. 54—"A" Post Moulding Attachment

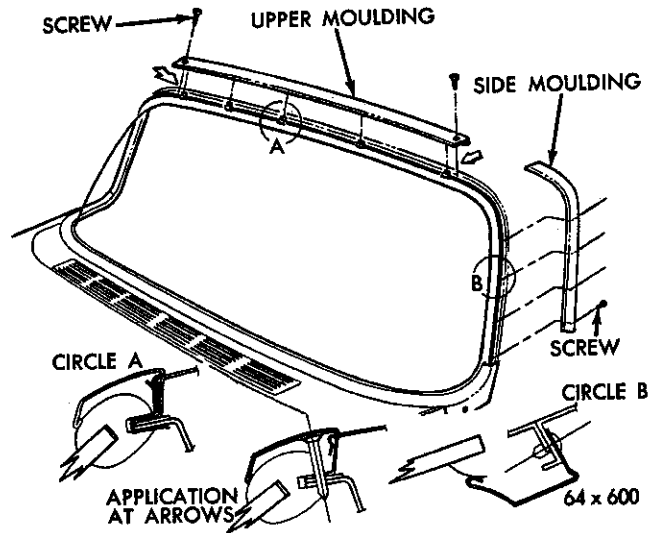

Fig. 55—Windshield Upper and Side Moulding Attachment

of the one-piece type with an integral outside locking lip, as shown in Figure 53. The windshield is a single piece of curved glass and is inserted in the glass channel of the weather strip. The windshield and weather strip are held in the body opening by the pressure of the closed locking lip.

Removal

- (1) Cover the adjacent cowl, hood and fender area with a protective covering.
- (2) Disengage the "A" post side mounting screws from the moulding (Fig. 54).
- (3) Remove the "A" post lower moulding attaching screws and remove the moulding (Figs. 55 and 56).
- (4) With a suitable tool carefully raise the extreme

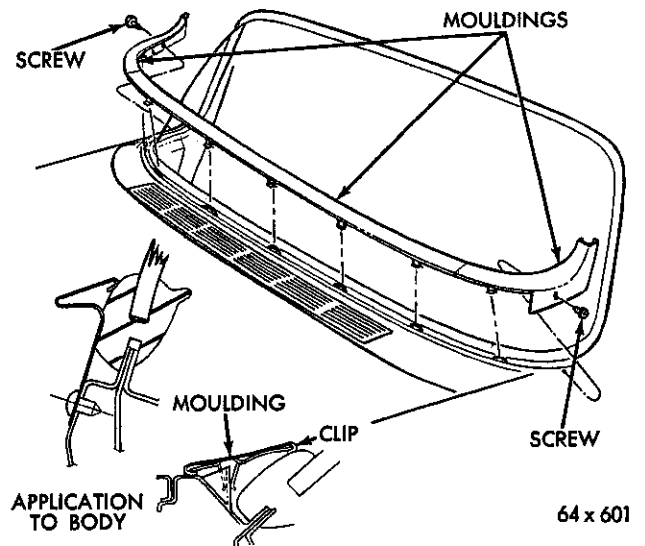

Fig. 56—Windshield Lower Moulding Attachment

end of the upper and lower moulding from the clips and remove the mouldings.

(5) On Imperial models remove the upper and lower center clips.

(6) Carefully remove the sealing compound from around the weather strip and body opening.

(7) Pry the lid of the weather strip apart, insert the fibre tool, twist slightly to unlock, while moving the tool across the cowl, over the top and around the sides of the weather strip to completely unlock the locking strip (Fig. 57).

(8) With a helper supporting the opposite end of the windshield, exert pressure to force the windshield out of the weather strip and carefully remove the windshield glass from the vehicle.

A windshield which has a crack originating from under the weather strip indicates the possibility of a pressure crack. Before installing a new windshield, it is advisable to inspect the windshield fence and opening clearances. The weather strip fence can be straightened and the opening clearances can be measured as follows:

(1) Remove the windshield weather strip.

(2) Install the glass in the opening with six four-inch long pieces of weather strip, as shown in Figure 58). (This is enough to support the windshield in place).

(3) Measure the clearance between the glass and the fence. A properly centered glass has $2\frac{1}{64}$ to $3\frac{3}{64}$ inch clearance on all sides, and $\frac{1}{8}$ to $\frac{1}{4}$ inch distance between the outer edge of the glass and the centerline of the fence.

Any spot that varies should be reworked by either grinding or straightening the fence.

Installation

(1) Inspect the moulding retaining clips around the windshield opening (Figs. 55 and 56).



Fig. 57—Locking the Windshield Weatherseal

(2) Apply a generous coating of sealing compound to the body fence and to the lip of the weather strip where it contacts the opening frame; completely around the weather strip.

(3) It is advisable to inspect and seal the seam joint between the roof panel and windshield opening fence.

(4) Form a ball of sealing compound and place it in each moulding retaining clip bolt holes.

(5) When installing the mouldings, press the retaining clip bolts through the balls of the sealing compound.

(6) Use black weather strip cement to seal between the windshield glass and the weather strip.

(7) Insert the nozzle of the dispensing gun about $\frac{1}{8}$ inch between the glass and weather strip.

(8) Apply a bead of cement between the glass and weather strip.

(9) Apply about three feet at a time, clean the excess off with a cloth moistened with solvent.

(10) Place the glass in position across the cowl.

(11) Slide the upper edge of the glass into the channel of the weather strip.

(12) Pound the glass with the palm of the hand, using an upward motion, until glass is fully seated in the channel of the weather strip at top, bottom and sides of glass.

After properly seating glass in the weather strip, strip in glass with a wedge-shaped tool of hardwood or fibre (Fig. 57) inserted between the weather strip and glass at either corner to strip glass into weather strip. Slide the tool across the top, bottom, and around the sides of the weather strip to properly seat the glass in place (Fig. 57).

NOTE: Always work the tool across the top down each side and over the bottom.

(13) Seal the rear edge of the weather strip all around the glass opening.

(14) Align and install the upper windshield moulding over the top of the windshield; on Imperial models only, make sure to exert sufficient pressure on the center of the moulding to force the moulding all the way down on the clips.

(15) Align and install the lower center moulding.

(16) Install the lower cowl side mountings and attaching screws. Be sure the lower cowl side mouldings overlap the lower moulding to insure proper installation.

(17) Slide the door hinge pillar ("A" post) lower side mouldings into position with the lower end overlapping the cowl moulding upper end of side moulding into position overlapping the upper moulding.

Install the screws and tighten securely.

(18) On Imperial models, install the upper and lower center clips.

(19) Install the windshield wiper arms and blades, then tighten the windshield garnish moulding attaching screws securely.

(20) Clean the windshield, using a suitable solvent, then test for water leaks.

66. CONVERTIBLE WINDSHIELD GLASS

(1) Cover up the adjacent cowl, hood and fender area with protective covering.

(2) Release the top locking mechanism and push the top header from the windshield frame to expose the screws holding the moulding.

(3) Remove the windshield wiper arms and blades.

(4) Remove the upper header moulding, attaching screws and remove the moulding.

(5) Pry the header moulding up slightly to clear the moulding from the weather strip then disengage from the header and remove, as shown in Figure 58).

(6) Remove the screws attaching the inner and outer side "A" post side mouldings.

(7) Remove the sun visors.

(8) Remove the screws attaching the header trim cap to header.

(9) Remove the windshield glass.

Installation

Install the windshield on the convertible in the same manner as described in "Windshield Glass Installation," then continue as follows:

(1) Slide the header cap moulding up against weatherstrip.

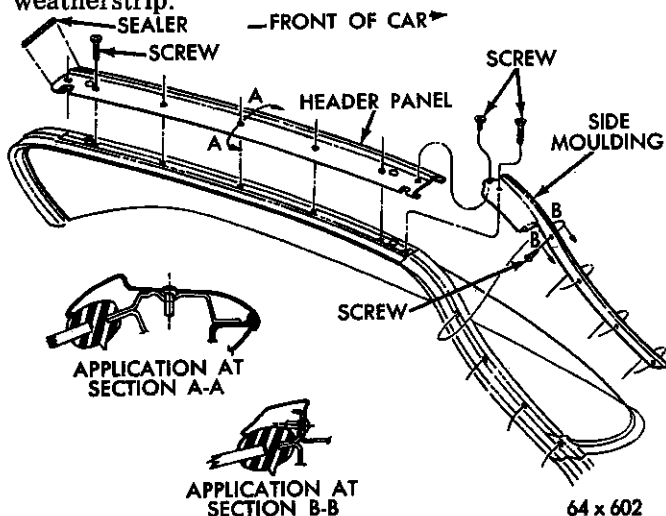

Fig. 58—Windshield Header and Side Moulding Attachment (Convertible)

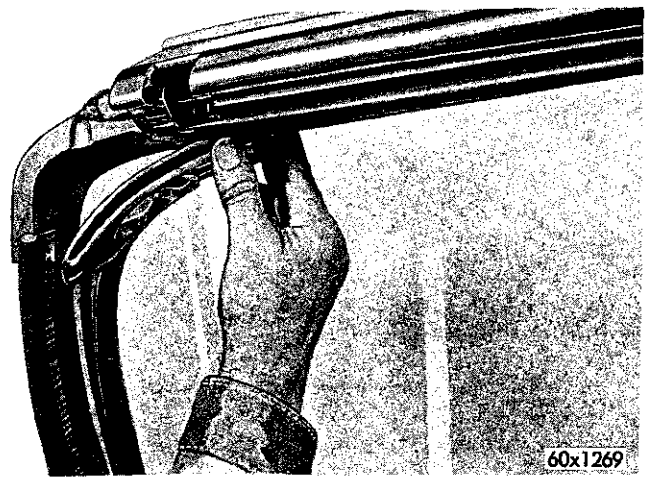

Fig. 59—"A" Post Inner Side Moulding

(2) Force the moulding against the weather strip, then press the rear edge down over the header.

(3) Install the screws to hold in position, then tap lightly with a rubber hammer to seat (Be sure the cap is evenly spaced across the header).

(4) Install the screws and tighten securely.

(5) Install the inner and outer trim mouldings (Refer to Figs. 58 and 59).

(6) Press tightly against the weather strip, engage with the header, and lower moulding, then press down over door hinge pillar ("A" post) and install the retaining screws.

(7) Seal the windshield.

(8) Install the sun visor and wiper arms. Test for leaks and clean the windshield.

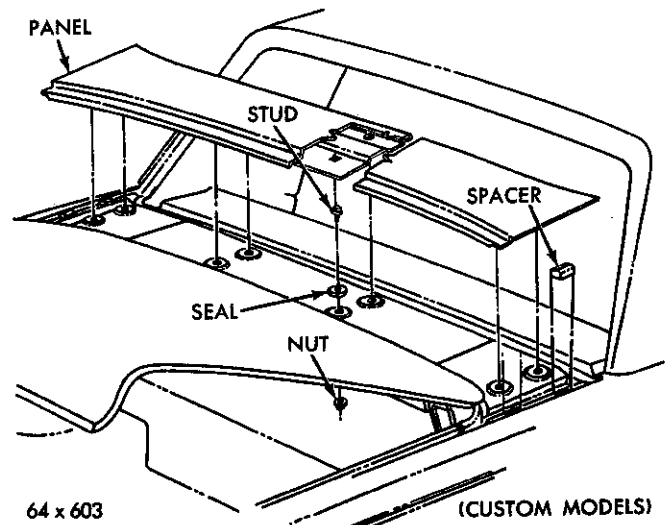

Fig. 60—Deck Lid Opening Upper Panel (Imperial)

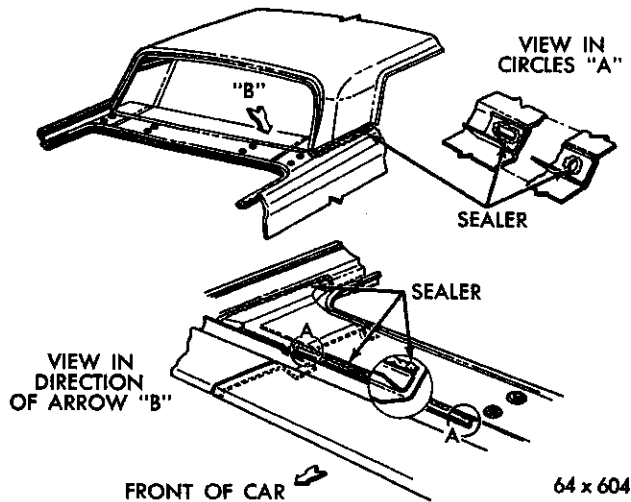

Fig. 61—Sealing Deck Lid Opening Lower Panel

67. REAR WINDOW GLASS

Removal

- (1) Cover the rear deck, rear window and quarter panel areas with protective covering.
- (2) Remove the upper, lower, and center moulding retaining clips.
- (3) Remove the upper and lower and center weather strip mouldings (Figs. 60 and 61).
- (4) Using a fibre wedge, loosen the weather strip from the rear window fence, both inside and outside lips.
- (5) With an assistant steadying the glass on the outside, push against the glass at one of the upper corners, from inside the car, and remove the glass and weather strip from the fence. **Gloves should be worn as a precautionary measure.**
- (6) Place the glass on a cloth covered bench and carefully remove the weather strip from the glass.
- (7) Remove all sealer from the glass, weather strip and rear window fence.

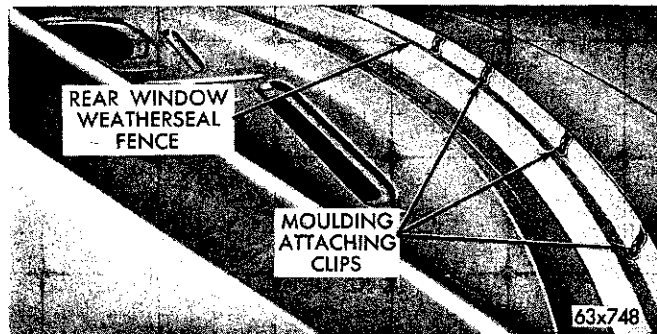

Fig. 62—Rear Window Moulding Attaching Clips

Installation

- (1) Inspect the rear window fence to be certain it is clean, smooth and straight and the moulding clips are correctly positioned (Fig. 62).
- (2) Flow a continuous ribbon of cement on each lip and around the entire length of the glass groove of the weather strip (Fig. 63).
- (3) Install the weather strip on the rear window.
- (4) Install twine into the groove of the weatherstrip that seats on the rear window fence.
- (5) The ends of the twine should be at the top center section of the weather strip (Fig. 63).
- (6) With an assistant, position the rear window glass and weather strip in the rear window opening.
- (7) With the assistant holding the glass in position, enter the car and pull the twine slowly to seat the weather strip on the fence.
- (8) With the palm of the hand tap the rear window glass, on the outside, to make certain it is fully seated.
- (9) Seal the weather strip to fence areas, on the outside only. Remove all excess sealer.

68. FRONT DOOR VENT WING

Removal (Imperial)

- (1) Remove the inside handle, trim panel (disconnect the window control switch) and remove the weather shield.
- (2) Remove the vent wing frame adjustment lock nut and washer, at the lower end of the vent wing frame division bar and run channel.
- (3) Remove the three vent wing frame attaching screws (Fig. 12).

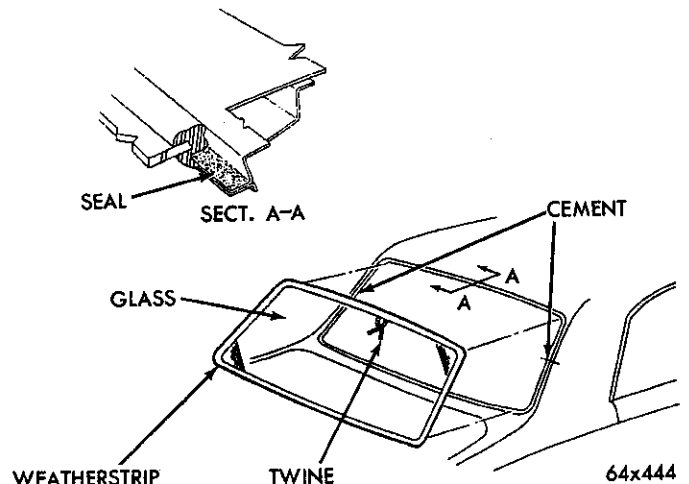

Fig. 63—Rear Window Installation

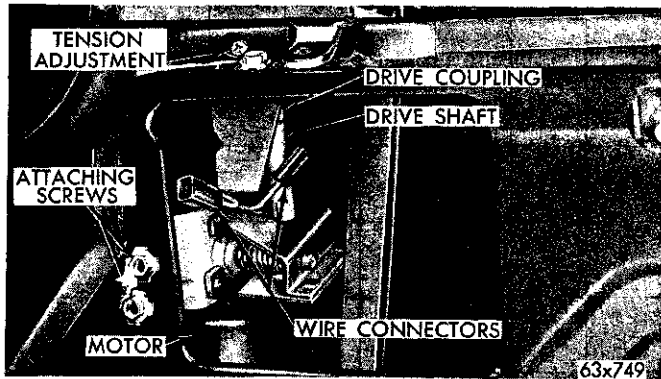

Fig. 64—Electric Operated Vent Wing

(4) Run the door glass down and tip the vent wing to the rear.

(5) Pull the vent wing frame assembly up and out of the door frame.

NOTE: Electrically operated vent wings (Fig. 64) are coupled to the drive motor by a rubber coupling and it will not be necessary to remove the motor to remove and replace the vent wing assembly.

Removal (Chrysler)

(1) Remove the inside handles, trim panel (disconnect the battery and the electric window switch if so equipped) and the weather shield.

(2) Remove the vent wing frame adjustment lock nut and washer, at the lower end of the vent wing frame division bar and run channel.

(3) Remove the vent wing frame attaching screws (Figs. 65 and 66).

(4) Run the door glass down and tip the vent wing assembly to the rear.

(5) Pull the vent wing assembly up and out of the door frame.

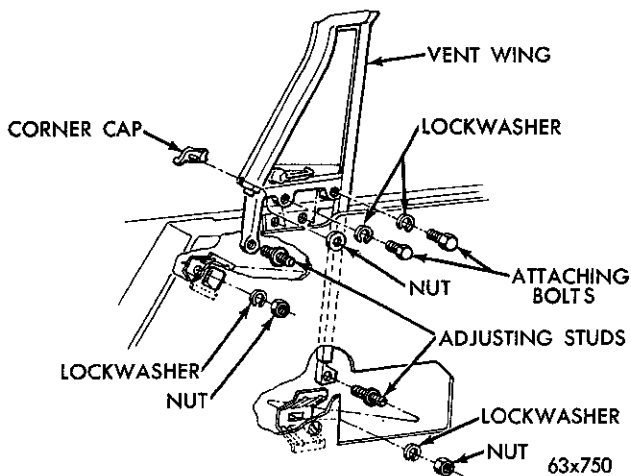

Fig. 65—Vent Wing Attaching Points (All Chrysler Models except 4-Door Sedan)

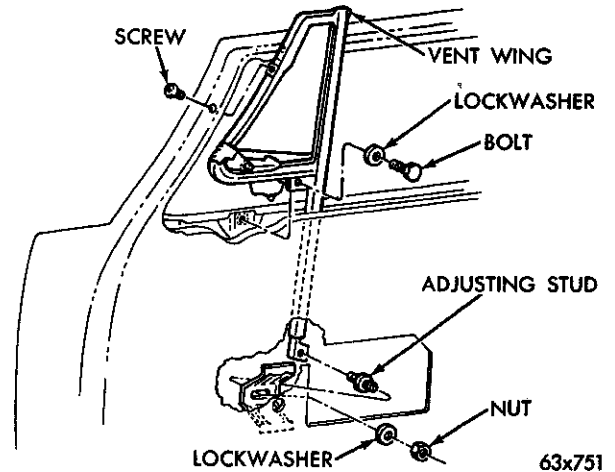

Fig. 66—Vent Wing Attaching Points (Chrysler 4-Door Sedan)

Installation

(1) Insert the vent wing assembly down into the door frame.

(2) Install the vent wing attaching screws finger tight.

(3) Install the vent wing lower adjusting screw lock nut and washer.

(4) Close the door and inspect the vent wing alignment with the "A" post and the roof rail weather seal.

(5) Correct any misalignment (Figs. 67 and 68) and tighten the attaching bolts and adjusting screw lock nut.

(6) Install the weather shield, trim panel (connect the wires to the control switch) and the inside handles.

69. FRONT DOOR GLASS

Removal (Imperial Models)

(1) Remove the inside handle, trim panel (discon-

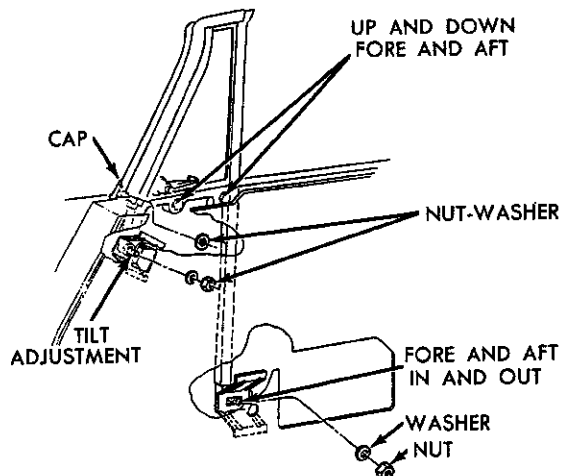

Fig. 67—Vent Wing Adjustments (Chrysler)

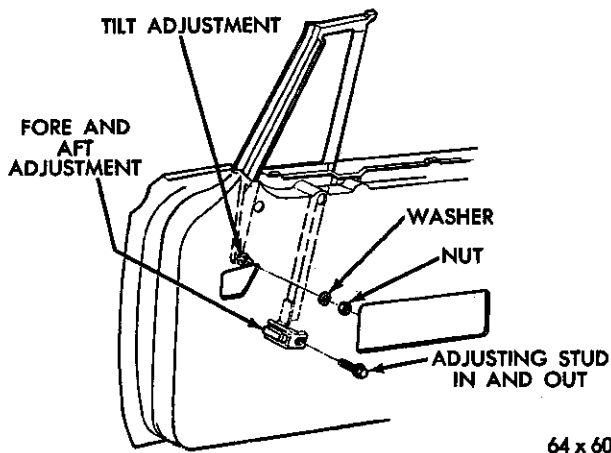

Fig. 68—Vent Wing Adjustments (Imperial)

nect the wires from the control switch) (if so equipped) and remove the weather shield.

(2) Run the door glass to the down position and remove the up stop brackets (Fig. 13).

(3) Remove the two screws and studs from the window regulator arms (Fig. 69).

NOTE: Care should be taken not to lose the washers between the regulator arm and roller.

(4) Raise the door glass up and out of the run channels.

(5) Remove the rollers from the glass lower frame.

Installation

(1) Install the rollers in the roller tracks of the glass lower frame.

(2) Lubricate the rollers and roller run channels.

(3) Install the rollers into the run channel and lower the glass down into the door frame.

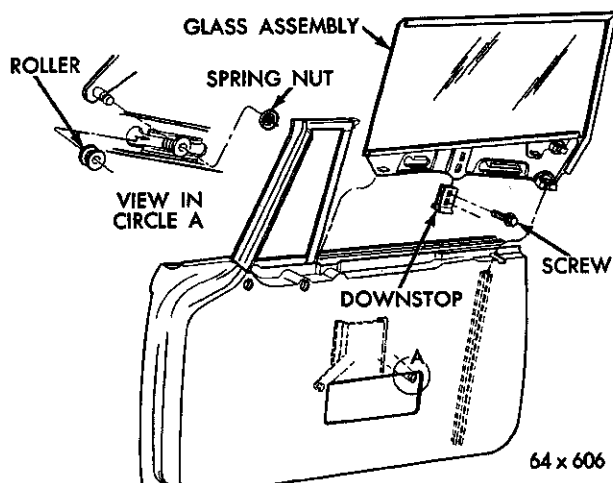

Fig. 69—Front Door Glass and Frame (Imperial)

(4) Install the stud, washer and screw through the roller and regulator arm.

(5) Install the up stops only finger tight.

(6) Close the door and run the glass up to the aligning position with the vent wing frame and roof rail weather seal.

(7) Set the up stops in this position.

(8) Run the window up and down several times and test for ease of operation and alignment.

(9) Install the weather shield, trim panel (connect the wires to the control switch) (if so equipped) and the inside handle.

Hard Top, Convertible, Town and Country, Manual (Chrysler) Removal (Fig. 70)

(1) Remove the inside handles, arm rest (if so equipped), trim panel and weather shield.

(2) Run the glass to the down position and remove the up stops.

(3) Remove the clips from the regulator arms and remove the washers and arms from the glass lower frame.

(4) Raise the glass up and out of the door frame.

Installation

(1) Enter the glass into the run channels and lower the glass to the down position.

(2) Lubricate the regulator arm rollers and glass lower frame guides.

(3) Install the regulator arms into the glass frame and install the washers and retaining clips.

(4) Install and adjust the up stops so that the top edge of the glass is level with the top of the vent wing frame and makes a good weather seal with the roof rail weather seal.

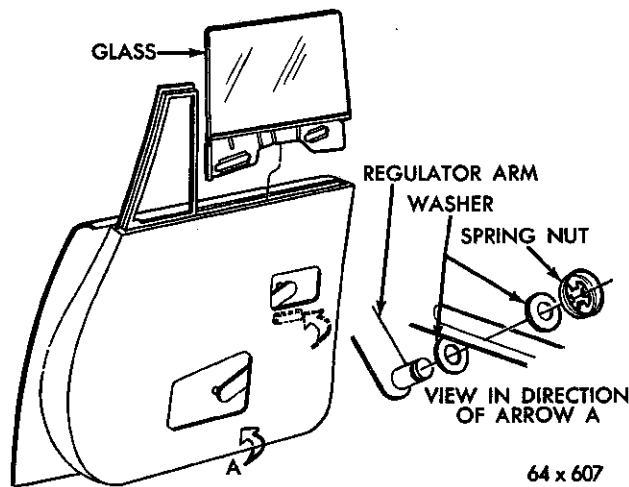

Fig. 70—Front Door Glass and Frame (Chrysler)

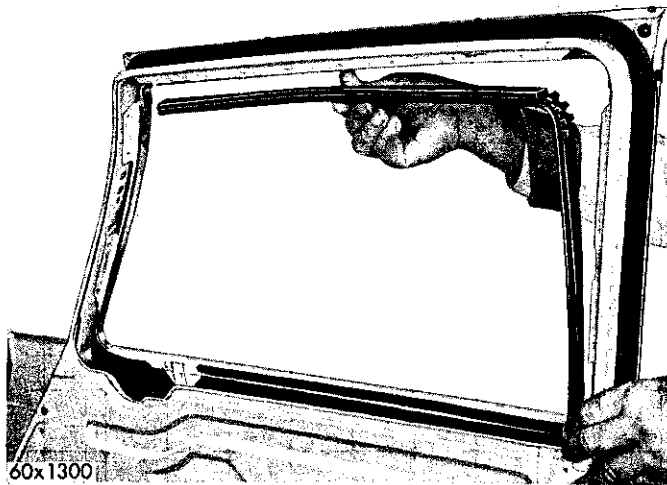

Fig. 71—Removing the Glass Run Channel (Chrysler)

(5) Install the weather shield, trim panel, arm rests (if so equipped) and the inside handles.

70. FRONT DOOR GLASS (Four Door Sedan) Chrysler

Removal

(1) Remove the inside handles, arm rests (if so equipped), trim panel and weather shield.

(2) Run the window to the down position and pry the forward end of the run channel down and out of the door frame (Fig. 71).

(3) Disengage the lower end of the run channel and work it up and out of the door.

(4) Disengage the regulator arms from the glass lower channel.

(5) Raise the glass up and out of the door frame.

Installation

(1) Place the glass down into the door frame.

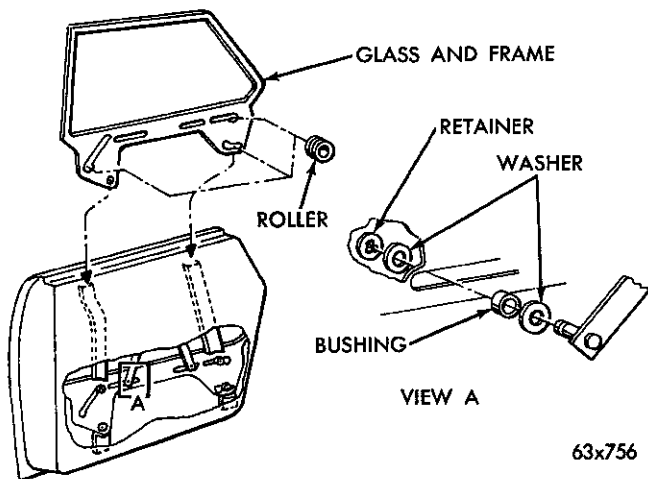

Fig. 72—Rear Door Glass (Chrysler—All Except Sedan)

(2) Work the run channel down into the door and engage the lower end with the door frame.

(3) Work the run channel into place and tuck the upper front end up and against the ventilator frame.

(4) Lubricate the regulator arm pins, rollers and window lower channel guides.

(5) Engage the regulator arms into the glass lower channel and attach the retaining clips.

(6) Operate the glass up and down several times and check for ease of operation.

(7) Inspect and adjust the down stop (The top edge of the door glass should be level or slightly below the door frame).

(8) Install the weather shield, trim panel, inside handles and arm rests (if so equipped).

71. REAR DOOR GLASS (Four Door Hard Top and Town and Country) (Figs. 72 and 73)

Removal

(1) Remove the inside handles, remote door lock lever, arm rest (if so equipped), the trim panel and weathershield.

(2) Run the door glass to the down position and remove the regulator arm attaching retainers.

(3) Disengage the regulator arms from the glass lower channel.

(4) Remove the glass stops and raise the glass and channel up out of the door frame.

Installation

(1) Lubricate the guides and rollers and enter the glass down into the door.

(2) Engage the regulator arms into the glass lower channel and install the retainers.

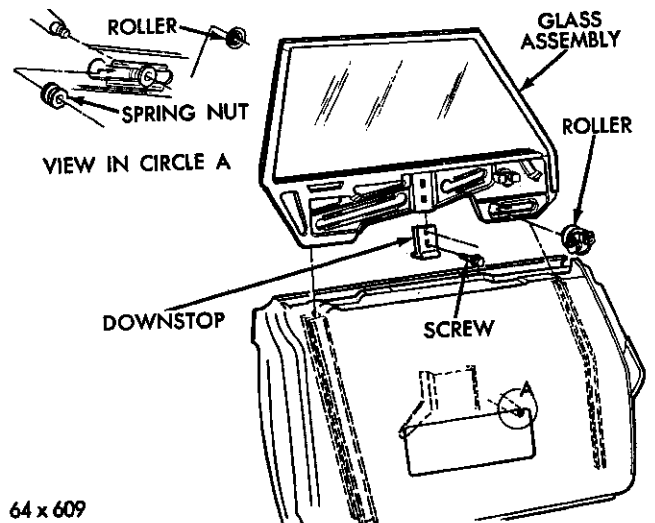

Fig. 73—Rear Door Glass Assembly (Imperial Four Door Hard Top)

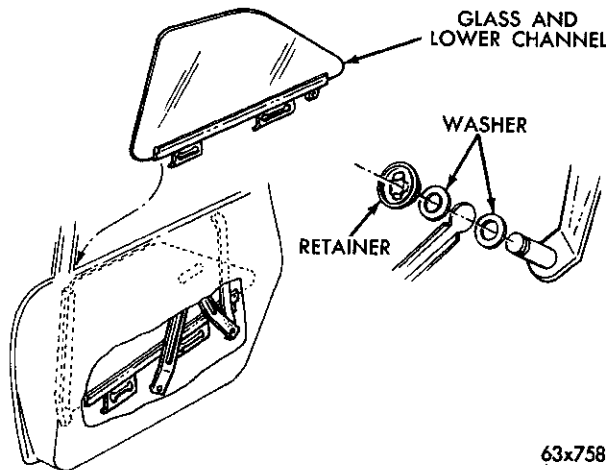

Fig. 74—Rear Door Glass Assembly (Chrysler Four Door Sedan)

- (3) Close the door and raise the glass to sealing position with the roof rail weatherseal.
- (4) Install and adjust the up stops.
- (5) Install the weathershield, trim panel, arm rest (if so equipped), the inside handles and the remote lock lever.

72. REAR DOOR GLASS (Four Door Sedan) (Fig. 74)

Removal

- (1) Remove the inside handles, arm rests (if so equipped), remote door lock lever, trim panel and the weather shield.
- (2) Run the glass to the down position and remove the regulator arm retainers and washer.
- (3) Disengage the regulator arm from the glass lower channel.
- (4) Remove the glass run channel from the door frame.

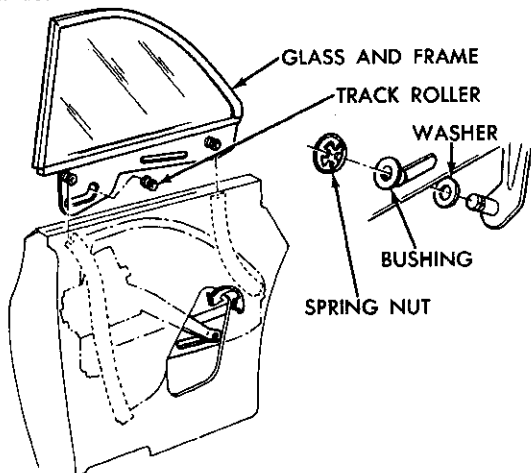

Fig. 75—Convertible Quarter Glass (Chrysler)

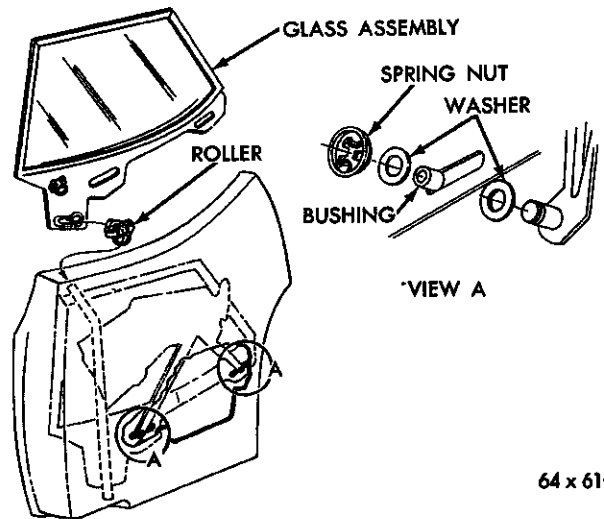

Fig. 76—Quarter Glass Assembly (Chrysler Hard Top)

- (5) Raise the glass up and out of the door frame.

Installation

- (1) Lubricate the regulator arm pins and the glass lower channel slots (Fig. 74).
- (2) Enter the glass down into the door frame.
- (3) Engage the regulator arms into the glass lower channel and install the washers and retainers.
- (4) Install the run channel into the door frame.
- (5) Operate the glass up and down several times and check for ease of operation.
- (6) Install the weather shield, trim panel, arm rest (if so equipped), inside handles and the remote door lock lever.

73. QUARTER GLASS (Convertible and Hard Top)

Refer to Figures 75, 76-and 77 for the quarter glass attaching points.

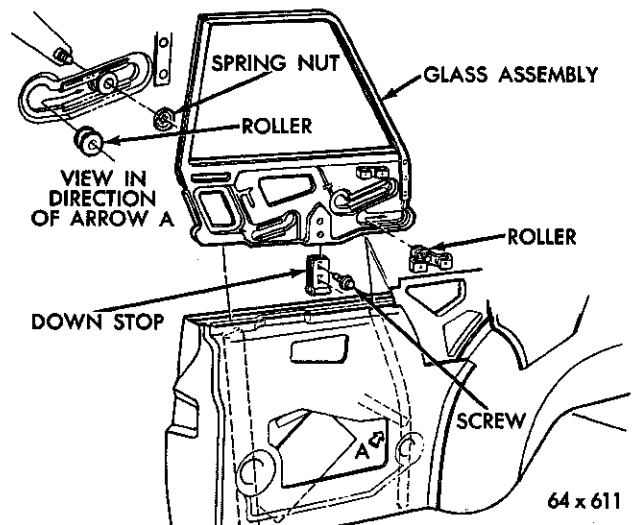

Fig. 77—Hard Top and Convertible Quarter Glass (Imperial)

PART 5

MAJOR BODY SERVICING

Servicing the "Unibody" should not present any unusual difficulties or necessitate additional equipment other than that required for the conventional and body repair. The use of heavy duty jacks and application of heat must be carefully controlled because of the difference of the gauge of the metal in the sub-frame of a unibody and the stress points developed in a single welded unit construction. It is possible to pull damaged areas back into alignment with the use of light-weight jacks and hydraulic body equipment without heating the metal.

Any attempt to cold-straighten severely bent floor pan side rails or brackets may cause ruptures of the welds or cracks in the bent part. Whenever heat is used to facilitate repair, the part or area should never be heated more than a dull red.

To align or square up the Unibody, take two opposite diagonal measurements between the body pillars, as shown in Figure 78 and 79. To check the frame body alignment, measure the distance between the points connected by line "A". Compare this measurement with the distance between the points connected by line "B". Compare all corresponding diagonals in this manner. The distance between the points connected by any two corresponding diagonals should be within 1/4 inch.

Place the vehicle on a level floor. Suspend a plumb bob directly under the center of points indicated in Figure 80 and mark the floor at these points. Repeat the procedure on each side of vehicle. The marks

made on the floor will represent the various points which can be checked diagonally. Use a measuring train for these measurements. Take the measurements between reference points such as crease lines or weld joints which are diagonally opposite each other on the two pillars being measured. Since all measurements should be made from the bare metal, remove all interior trim from the checking points.

In some cases, it may be difficult to obtain proper body alignment when repairing a body that is damaged on both sides. In these instances, horizontal and vertical measurements may be taken from a body of the same body style. Once these basic dimensions are taken and established on the damaged body, alignment can be made by diagonal measurements taken from the measuring point on two pillars.

When two opposite diagonal measurements are not the same, the body should be forced in the direction of the short diagonal. The distance to force that part of the body will be a little more than one half the difference in the two diagonal checking points to compensate for "spring-back".

Door openings are checked in the same manner as the body. Horizontal, vertical, and diagonal checking points are established on all four sides of the door opening that is being measured.

Body bolt inspection and tightening should be performed regularly. Imperial models have 12 body bolts (except the convertible which has 14 bolts). Chrysler models have 10 Unibody to fore structure bolts.

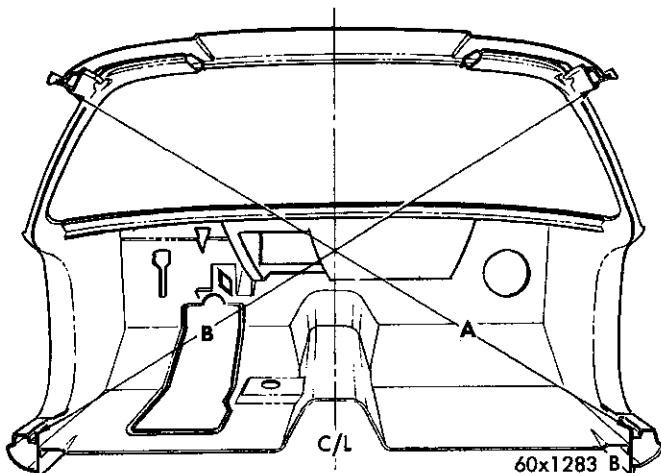

Fig. 78—Aligning Body at Center Line of Front Pillar (Chrysler)

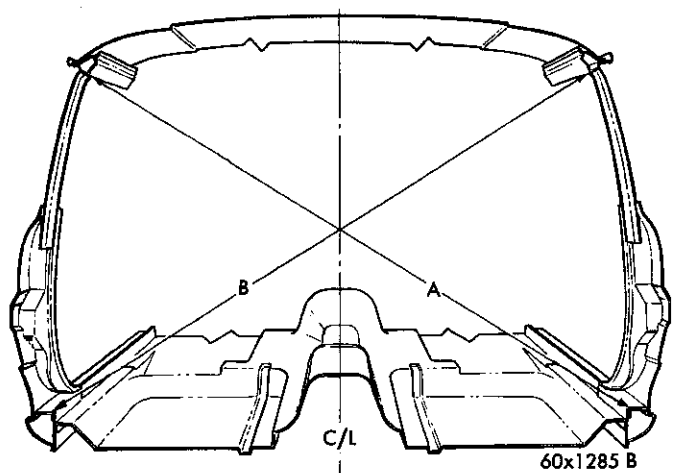

Fig. 79—Aligning Body at Center Line of Center Pillar (Chrysler)

If tightening bolts and screws located on such an assembly as deck lid, doors, hood, radiator support, and front end does not eliminate squeak or rattles, the trouble is probably caused by misalignment and incorrect adjustment procedures.

74. REPLACEMENT OF BODY PANELS ASSEMBLIES (All Models)

NOTE: When repairing damaged panels and other body parts, it may be less expensive to replace rather than repair a damaged panel or parts. The decision to replace rather than repair a panel should be based on the cost or replacement (parts plus labor) as against cost of repairs (labor) only. Satisfactory decisions can be derived only by becoming familiar with the various replacement panels and assemblies available.

With proper equipment, an experienced body repair man can repair a damaged area in a body panel by one of three methods:

- (1) External or surface damage that can be bumped out or refinished.
- (2) External damage that can be repaired by removing a complete panel and installing a service panel.

(3) Extensive damage necessitating the removal of the outer panels and the realignment or replacement of sections of the fore-structure. **When performing repairs of this type, measure sufficient overlap to assure an adequate area for a strong welded surface.**

In cases where only a portion of a panel requires replacement, a section of a service panel can be used. Complete service panels are available if the area is extensively damaged.

If a complete panel requires replacement, the following procedure is one of several methods that can be used for cutting out and replacing a portion of the quarter panel.

Rough out and shape as much of the damaged area as possible. Measure the piece of metal to be cut out. This measurement should be taken from a definite point such as a moulding or bead.

Make the corresponding measurements on the service panel. Be sure measurements are taken from the same points. Scribe a line around the area to be cut from the service panel.

Drill a 1/4 inch hole at any one corner of the scribe line as a starting point for cutting. Use a suitable cutting tool and cut the new piece out along the scribed line.

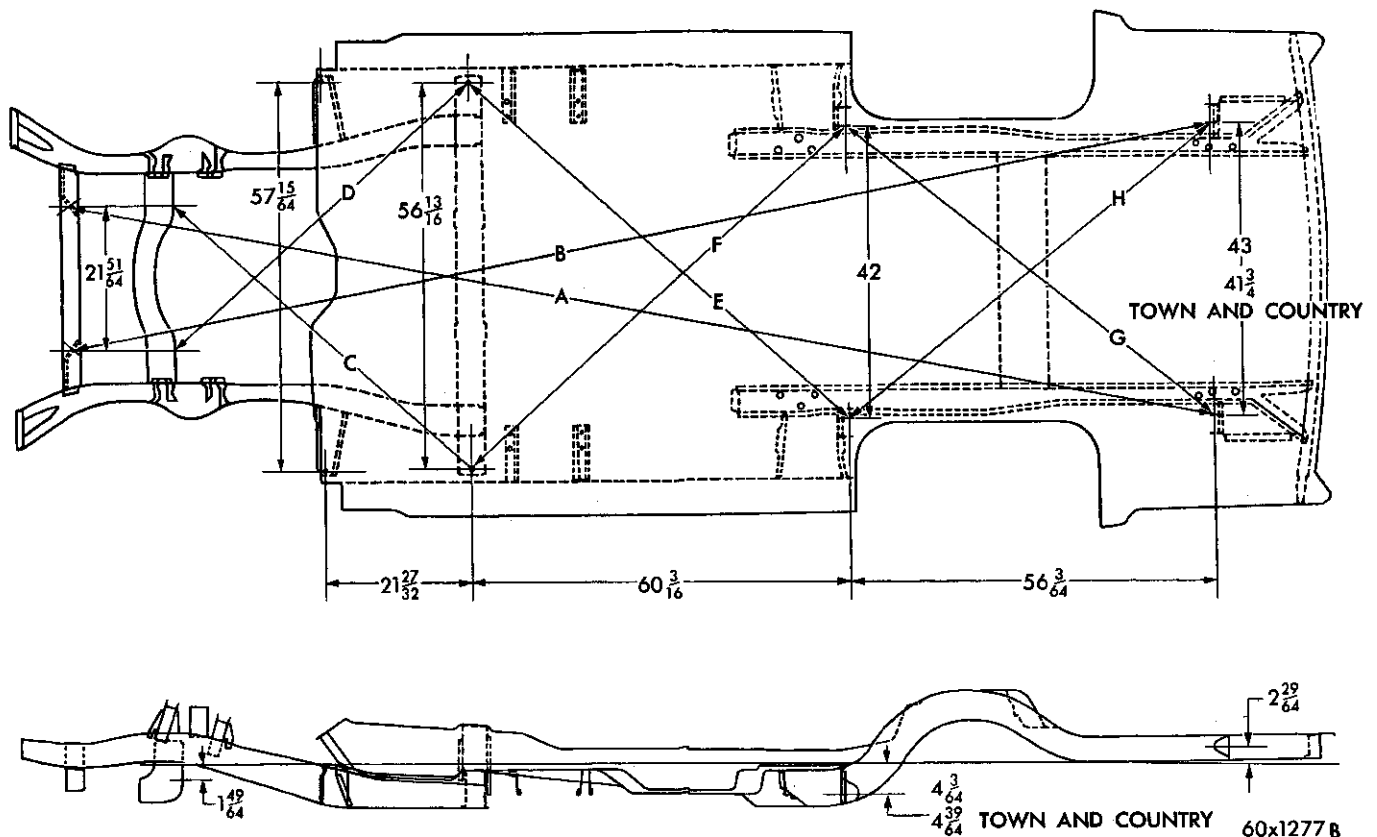

Fig. 80—Frame to Under Body Alignment (Chrysler)

Straighten the edge of the piece that was cut out, and position it over the damaged area as a template. Fasten the cut out section of the service panel over the damaged area of the body, and scribe a line around the panel. Cut out the damaged area.

If the piece to be replaced is at the pillar or at any point where the panel is spotwelded to other parts of the body, such as the body side panels, lower edge or wheel housing assembly, the damaged piece should be split at the weld if possible. To split a spotweld, drive a sharp chisel between the two pieces of metal at the weld. In difficult cases, a spotweld may be broken by drilling a 1/4 inch hole into the center of the weld.

Straighten the cut edge of the panel. Fit the service panel portion into the cut out area in the body panel. Be sure that the two panels do not overlap. Tack-weld at intervals, let the metal cool, and make a continuous weld around the two pieces. Wet asbestos putty may be used to prevent the heat from traveling. Weld about 6 inches at a time. Stagger the welds to prevent excessive distortion.

Hammer the weld below the contours of the surface not more than 1/16 inch with a grooving dolly.

Metal finish the repair area and file it smooth, taking care to produce the correct contour.

Grind the welded area, clean, and tin.

Fill in with solder, taking care that sufficient solder is applied so that the final metal finish will not have indentations.

Metal-finish the panel to prepare it for painting.

Although this procedure is used here for quarter panel repairs, it can be applied to other sections of the body as well.

75. PAINT REFINISHING

Chrysler built cars are finished with a Luster-Bond Super Enamel. These super enamels provide the utmost in appearance and durability.

To repair individual or small panels, an air dry or low bake enamel has been developed and has the same characteristics of appearance and durability as the original baked enamel. Repainting a complete fender, door or body panel is recommended and will be found to be more satisfactory than to try and do a touch up on a large surface.

The use of lacquer for spot painting will usually prove unsatisfactory as the sheen or gloss of lacquer and enamel do not match. Lacquer has a tendency to oxidize and fade over long exposures to weather.

76. PREPARATION

The surface to be finished must be thoroughly cleaned and free from oil, grease, rust, moisture,

polishes and waxes containing silicone, resins or oils. Crawling of the paint, improper wetting of the surface, craters or fish eyes and poor adhesion will result if not properly prepared.

NOTE: Test to determine if silicone polishes or waxes have been used. Spray a small amount of enamel on a small vertical area of the vehicle. The presence of silicone polishes or wax will appear as "craters" or "fish eyes" before the enamel dries. The test area may be washed off with reducer while the paint is still wet.

The new super enamel is hard and a second or repair coat will not bite in or attack the finish to give good adhesion. To accomplish this a light sanding with No. 400 wet or dry abrasive paper until the glass is dulled, will give enough tooth for the refinishing enamel to adhere to. After sanding, the surface to be painted should be thoroughly washed with a suitable solvent.

77. REMOVING OLD FINISH

The old finish is usually removed by grinding. A No. 16 open coat grinding disc removes paint with a minimum clogging of the paper. The exposed metal should be sanded with No. 50 paper then followed with No. 220 paper and all edges of the paint film should be feather edged with No. 320 and finished with No. 400 wet and dry paper.

On large areas and complete panels it is sometimes more efficient to use paint remover. Be sure to select a paint remover that is water neutralizing.

Sand blasting is an excellent method of removing paint, particularly on complete refinish jobs. When sand blasting it is advisable to remove all mouldings and trim. Thoroughly mask all glass.

A vibrating feather edger may also be used to finish small areas or panels.

After the metal has been properly sanded it should be thoroughly washed with a good wax and grease remover.

CAUTION: After the metal has been cleaned do not rub the metal with bare hands as the normal oil of the skin may leave a thin film on the metal and cause poor adherence or peeling.

The metal is now ready to be treated with a good metal conditioner and rust inhibitor. This may be applied at room temperature and it will create a light etching action and will assure maximum adhesion to the metal.

CAUTION: Be certain to follow the manufacturers instruction for maximum results.

78. REFINISHING

The finished paint job will be no better than the surface that it covers so particular attention should be paid the priming and surfacing of the metal. It is advisable to apply two or three medium coats of primer rather than one heavy coat. This will reduce the drying time between coats. Use No. 320 or 360 paper and sand each coat to remove any blemishes or scratches. Finish the last coat with No. 400 wetpaper.

79. APPLICATION

To obtain a good color match make certain to reduce the enamel in accordance with the instructions

on the container. It is always preferable to use a little more rather than less reducer. A good match will generally result when most colors are sprayed 6 to 8 inches from the surface being painted and air pressure regulated to 40 to 45 pounds at the gun. Using an inferior or insufficient amount of reducer will produce a spray that is slightly dry and light in texture. Fast drying reducer and high air pressure have the same effect. Excessive slow drying reducer and heavy wet coats with low air pressure produce very dark shades. In the application of non-metallic colors, the number of coats or final film thickness effect the final color. It has been found that the thicker the coat the lighter the shade.



PART 6

CONVERTIBLE MAINTENANCE

80. BODY ALIGNMENT—Imperial Only

An important factor in the proper alignment of the doors and convertible top is the attachment of the body to the frame of the car. Uneven tightening of body bolts, the use of too many or not enough shims, or overtightening of the body bolts may result in distortion of the body sill and cause misalignment of the doors and top fit at the header.

Therefore, before any adjustments are performed to correct the door or the top misalignment, be sure that all the body bolts are tightened to 18 foot pounds torque. In some cases, it may be advisable to loosen the body bolts and drive the vehicle a short distance to permit the body to settle evenly on the frame. Then, tighten the bolts to the specified torque.

If the body shimming is necessary to obtain the proper door alignment, this should be done before attempting to make the adjustments of the top linkage.

Figure 81 illustrates how to correct a door fit which is tight at the top and open at the bottom. If the door fit were open at the top and closed at the bottom, it would be necessary to add shims at the body mounting near the front and rear of the door. In some instances, add shims on the right side of the car and remove them on the left side or vice versa. The important thing, however, to keep in mind is that shimming of the body as illustrated changes the fitting of the top header at the windshield frame.

81. OPERATING THE CONVERTIBLE COUPE TOP

To Lower the Top

Release the safety catch on the locking handle located in the center of the header, pull the handle

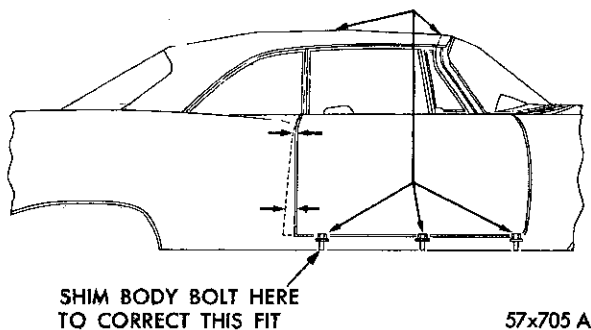

Fig. 81—Shimming Body for Door Alignment (Imperial)

down and to the rear. Push header free of windshield. Be sure the Convertible Top storage compartment is free of articles. On Imperial models unzip the rear window and drop into the storage compartment. On Chrysler models, the rear window need not be unzipped. Operate the engine in NEUTRAL at a speed above idle. Turn the top control switch located on the instrument panel to the right and hold in this position until the top is fully lowered. Fasten the top boot over the compartment snapping it at the sides and rear.

CAUTION: Never attempt to raise or lower the top while the vehicle is in motion. It is advisable to raise and lower the top at least once a month to keep the top mechanism in working condition.

To Raise the Top

Unsnap the top boot at the sides and rear and fold into the storage compartment. Turn the top control switch to the left and hold in this position until the header rests on the windshield. Zip up rear curtain. Pull the top down firmly on the top header. Push the locking handle all the way forward until the safety catch engages.

82. TOP ADJUSTMENTS

Convertible top adjustments are of two general classifications — minor and major. The minor adjustments are easily accessible and can be made without any major disassembly.

Minor Adjustments

The minor adjustments are provided to assist in aligning the top header in relation to the windshield header to prevent water and air leakage into this area; to improve top frontal area appearance and assure ease of operation in raising and lowering the top. They are also provided to assure correct alignment of the roof side rails with door and quarter glass to prevent air and water leakage. Adjustments are also provided to eliminate wrinkles in the top material.

Major Adjustments

The only major adjustment is at the prop control link bracket at the rear quarter panel. It is used to improve roof side rail alignment if minor hinge adjustments do not completely correct the condition. Making this adjustment involves removing the rear seat and quarter pocket panels.

Door and Glass Alignment

It is important to remember that before making any top adjustments, doors, vent wings and door and quarter glass must be properly aligned. Misalignment in any of these areas make it impossible to obtain satisfactory results from top adjustments alone. Glass up-stop adjustments should be made after the correct roof side rail alignment to limit the upward travel of the glass. This is necessary to assure effective sealing between the roof side rail weatherstrip and glass.

83. TOP HEADER

Seal

The entrance of water and air between the top header and windshield header is eliminated by a closed cell weatherstrip secured to the underside of the top header. The lip on the forward edge of the weatherstrip contacts the windshield header outside finish moulding.

Header Locating Dowels

Good weathersealing at the frontal area is dependent upon proper positioning of the top header on the windshield header. Two steel locating dowels, one assembled in each end of the top header, engage sockets in the windshield header to correctly position the top header. The sockets are slightly oversize to permit fore-or-aft or lateral top header movement for proper positioning.

The top header is adjustable at the front roof side rails to permit fore-or-aft and lateral movement. The header is attached to the side rails by two header-to-side rail screws on each side (Fig. 82).

Top Header Latching Mechanisms

The amount of pressure exerted by the weather-

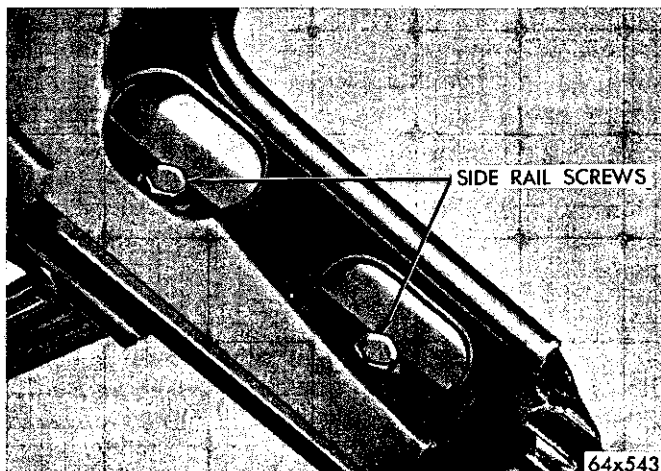

Fig. 82—Header Adjusting Points

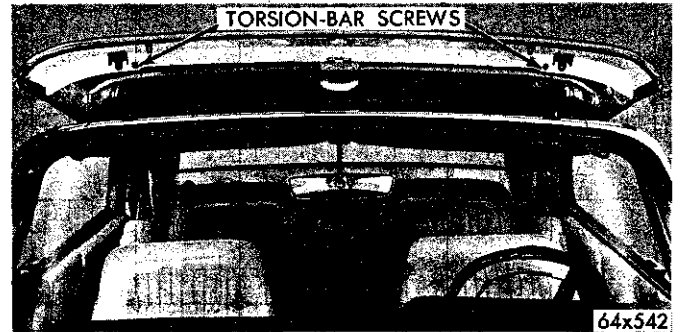

Fig. 83—Latch Mechanism Adjusting Points

strip against the finish moulding is controlled by the top latching mechanism attached to the top header.

The locking and unlocking effort of the latching mechanism is adjustable to control the pressure on the weatherstrip.

The single center-mounted latch adjustment is controlled by two torsion bar adjusting screws (Fig. 83). One is located in each side of the top header and they are accessible through holes in the underside of the top header near the locating dowels. Turn the screws counterclockwise to decrease the latching effort and clockwise to increase the latching effort.

84. TOP HEADER ADJUSTMENT

Incorrect alignment between the top header and the windshield finish mouldings may result in air or water leakage. Inspect the clearance between the header and the finish moulding for uniformity. If the top header is too far forward at one end or all across the finish moulding, the interference between the header and the finish moulding may prevent proper pressure on the weatherstrip when the top header is latched. This condition will also cause objectionable high locking and unlocking effort. The misalignment may also result in making it difficult to engage the top header locating dowels in their sockets.

To eliminate the interference between the header and the finish moulding, loosen the two vertically positioned header-to-side-rail screws in the header, inboard of the header panel. Adjust the header, as required, to provide the proper clearance.

Forward movement of the header will be limited by the amount of top material. Inspect the top header dowel engagement in the windshield before securing the screws. If there is interference between the dowels and sockets, adjust the header by loosening the two horizontally positioned screws on the inside surface of the header panel and the single clip screw on the header. Tighten the screws securely.

CAUTION: When servicing the top linkage, inspect for any sharp edges or burrs on the top linkage

or mouldings that can damage the top material. Dress or file them down. Also, watch for screws that are too long and can damage the top material. Cut off the excess length, or replace with shorter screws.

85. CORRECTING TOP HEADER WATER LEAKS

If adjusting the top header for uniform spacing and the latching mechanisms for proper header tension on the header weatherstrip does not provide satisfactory sealing, additional sealing on the underside of the header will be necessary.

Remove Weatherstrip Retainer

Lower the top and fold it back into the top well. Remove and discard the small curved black metal weatherstrip retainer and screws at each corner of the header. If the weatherstrip shows signs of distortion in this area due to the retainer, discard it. The weatherstrip cannot be reshaped to provide an effective seal.

Punch a three-sixteenths inch hole at each corner of the weatherstrip, midway between the two corner retainer screw holes. Drill a number twenty-eight hole in the top material retainer, at each corner, in line with the punched hole in the weatherstrip.

Remove the weatherstrip retainer and the top material retainers from the top header and discard the screws. New, longer screws must be used when the retainers are reinstalled.

Header-To-Roof-Rail Joint Sealing

Seal the joints between the top header and the front roof side rails by applying one-inch balls of body sealer to the notches formed by the joint between side rail and the top header.

Cement a strip of polyethylene foam seal, Part No. 2484159, across the header, close to the corners, and extending out one-quarter inch from the header inner panel at the ends. Install the top material and weather-strip retainers, using round washer head screws, No. 8-18 x 1/2".

Sealing Ends of Top Material Retainers

It is important to seal at both ends of the two curved top material retainers. Use a one-half inch ball of body sealer under the offset tab at the end of the curved retainer. Apply a four-inch length of sealer to the joint formed by the curved retainer and the header weatherstrip retainer.

Cementing Weatherstrip to Retainer

Apply a light coating of rubber cement on the inside of the weatherstrip retainer and the weatherstrip. Allow cement to become tacky on retainer and

weatherstrip before installing weatherstrip. Cementing the weatherstrip in place will hold it securely and enable the lip to provide a good seal at the windshield finish moulding.

Secure the weatherstrip at the corners with No. 8-18 x 1/2" round washer head screws and plain washers, 3/16 I/D x 5/8" x 1/32", using the three-sixteenths-inch holes punched in the weatherstrip.

Raise the top and carefully water test the area to check on the work performed.

86. VENT FRAME LEAK AT TOP EDGE

Water leaks at the top header can be corrected by the following method. Latch the top down securely and close the door. From the inside of the car, inspect for a possible leak at the pillar-to-vent-wing seal. Look for water traces or light anywhere along the top edge of the vent wing frame.

Inspect the condition of the seal from outside the car. If there is a leak, it may be that the sealing lip of the roof rail weatherstrip doesn't seal properly along the top edge of the vent frame. It is possible for water to leak in even where there seems to be no visible evidence of a leak.

Correcting Leak at Top Edge of Vent Frame

It may be necessary to either shim or trim off the top of the seal to get a good sealing lip along the top edge of the vent frame. When reinstalling the seal, be sure to clean the surface thoroughly of all old cement with a solvent. Clean the seal to remove any mold powder. Apply cement to the windshield pillar and the seal. When tacky, press the seal into place. It may be necessary to install a new seal to stop a leak at the upper edge of the vent wing frame.

87. ROOF SIDE RAIL ALIGNMENT

The roof side rail structure (Fig. 84) consists of

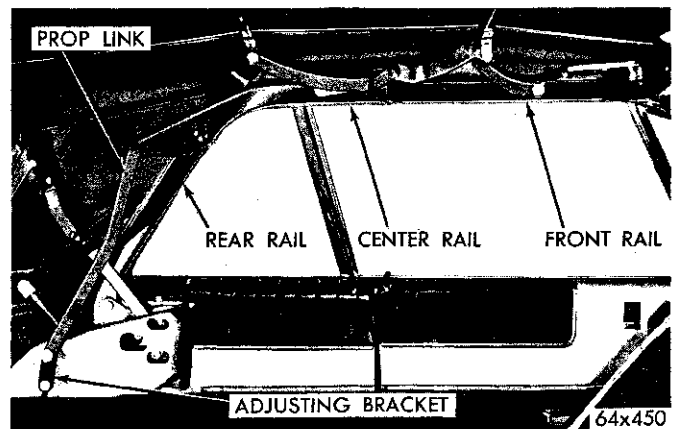

Fig. 84—Roof Side Rail Structure

three separate rails, hinged together to enable the top to fold into the wall when not in use. Hinges are provided between the front and center rails and the center and rear rails. The rails must be in good alignment and parallel to the top edges of the vent wings, door and quarter glass to provide a good weatherseal. Alignment of the rails is controlled by a set screw arrangement which consists of a socket-type set screw in one rail and a steel drive stud in the adjoining rail.

Side Rail Hinge Locations

The front hinge set screw is accessible from the top surface of the front rail and angles downward to the rear. It contacts the steel drive stud in the center rail to open or close the hinge, as required. The rear hinge set screw is located in the underside of the center rail and angles upward and to the rear. It contacts the drive stud in the rear rail. Access to the set screw can be made by removing the center roof side rail weatherstrip and retainer.

Front Hinge Misadjusted

Water and/or air leaks between the top and door or quarter glass may be caused by poor contact between the roof side rail weatherstrip and the glass or only a partial contact between the roof rails and the top edge of the glass. If inspection shows the leakage is due to a jackknifed condition at the hinge (Fig. 85), it will be necessary to adjust the hinge set screw to close the joint.

CAUTION: To avoid stripping the set screw threads, unfasten the top header latches to relieve tension on the linkage, before adjusting the set screws.

88. FRONT HINGE ADJUSTMENT

If the front hinge is jackknifed, use a one-eighth-inch Allen wrench and turn the set screw (Fig. 86) in a counter-clockwise direction to close the joint until

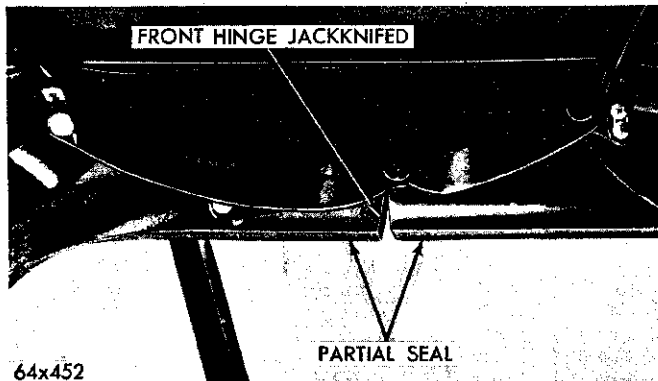

Fig. 85—Front Hinge Jack Knifed

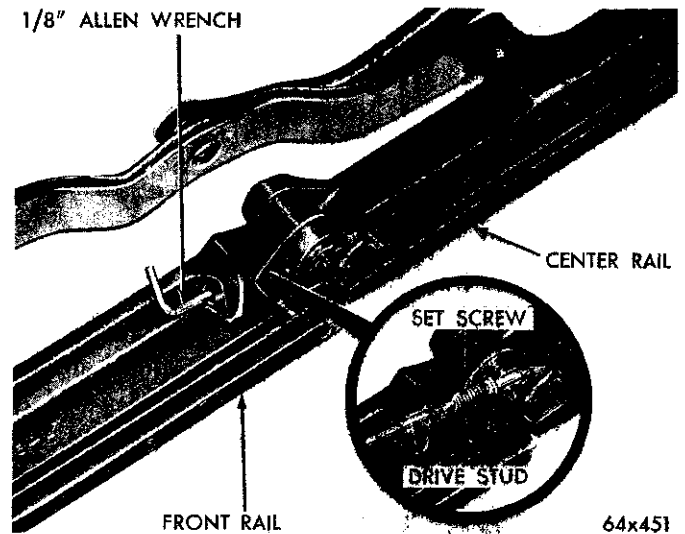

Fig. 86—Front Hinge Adjusting Screw

the front and center rails are parallel. Fasten the top temporarily to inspect parallelism and alignment with the door glass. Readjust the set screw, if necessary.

89. REAR HINGE ADJUSTMENT

Inspect the center and rear roof side rail alignment at the quarter glass. If additional clearance is noted in this area, as indicated by the hinge being jackknifed open, again unfasten the top header. Remove the side rail weatherstrip and retainer and adjust the rear hinge set screw (Fig. 87) from the underside of the center rail until proper alignment and clearance is obtained.

Adjusting the two hinge set screws will normally correct any roof side rail alignment problems, however, if an alignment problem still exists, and additional leveling of the roof side rails is required, the linkage through the main control prop link bracket can be adjusted.

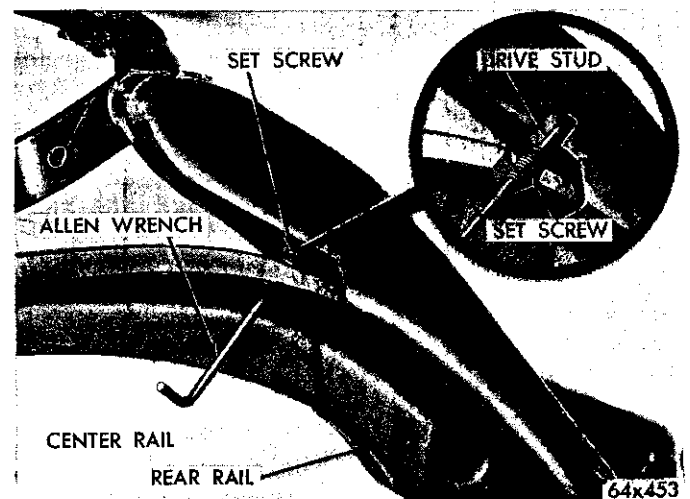

Fig. 87—Rear Hinge Adjusting Screw

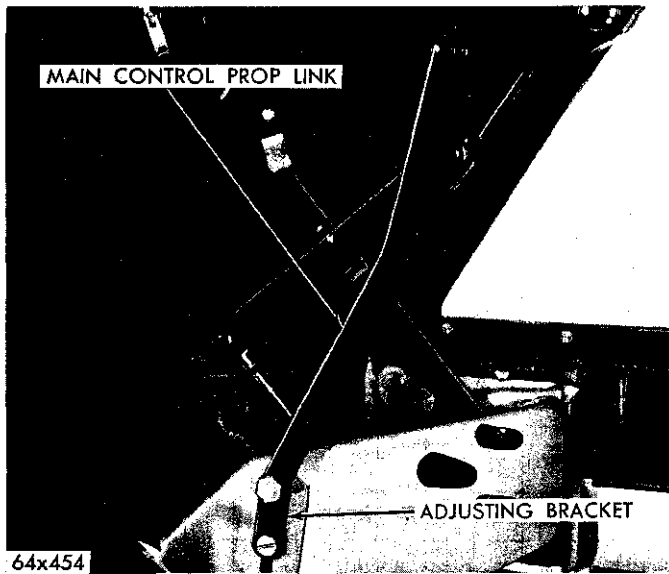

Fig. 88—Main Control Prop Link Bracket

90. MAIN CONTROL PROP LINK BRACKET ADJUSTMENT

To gain access to this bracket, remove the rear seat and the pocket panels on both sides. Unfasten the top header latches to relieve the tension from the linkage. The door glass and quarter glass must be raised to prevent the side rail structure from dropping when the adjusting bracket screws are loosened.

The serrated prop link adjusting bracket (Fig. 88) is attached to the quarter panel reinforcement by two screws threaded into a tapped plate. Loosen the screws just enough to permit moving the bracket up or down, as required. Raising the bracket and link causes the center rail to rotate on its pivot in the rear rail, lowering the front and center rails to improve the weatherstrip fit with the door and quarter glass. When proper alignment has been obtained, tighten the adjusting bracket screws. Inspect the side rail hinge adjustments, and adjust as necessary.

91. TOP SHIFTS TO ONE SIDE

If it is necessary to pull the top to one side to engage the locating dowels in their jackets in the windshield header or the top shifts to one side when raising the header from the windshield header, inspect the main prop link bracket adjustments. Brackets not adjusted uniformly, changes the operating angle of the linkage causing the top to twist when it is raised.

When one bracket is adjusted, be sure the position of the bracket on the opposite side is inspected and adjusted, if necessary.

NOTE: It should not be necessary to adjust the power guide link supports unless the top assembly has been removed for servicing or replacement of linkage parts. When this is done, be sure both supports are adjusted to provide identical travel of the piston rods.

92. POWER GUIDE LINK ADJUSTMENT

The link adjusting support is attached to the panel by two screws, which when loosened, permit forward or rearward movement of the support. It is important that the supports on both sides be positioned at approximately the same position. If one support is positioned rearward of the other one, it would cause the power piston rod linked to that support to start to actuate the linkage slightly ahead of the piston rod on the opposite side. This can cause one side of the top to twist slightly.

The rearward position of the support also increases the travel of the power piston rod, resulting in a small amount of overtravel when the top is fully raised. When the power is turned off, the power piston assumes its normal position due to leak-back in the hydraulic system.

93. FRONT TOP BOW ADJUSTMENT

If the top material at the front bow appears to hang down too low and interferes with the top edge of the door glass when the door is closed, adjust the number one top bow at the adjusting plate attached to the outer ends of the top bow (Fig. 89). This permits the bow to be moved up or down, as required.

If the roof side rails are exposed below the top material, the bow can be lowered. To adjust the bow, loosen the screw at each end and move the bow up or down, as required.

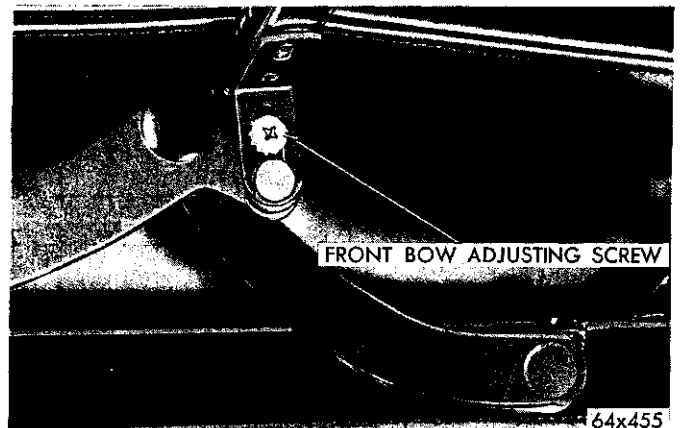

Fig. 89—Front Top Bow Adjusting Points

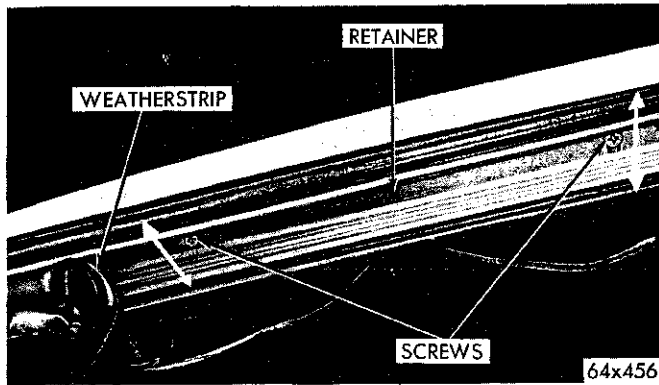

Fig. 90—Roof Side Rail Weatherstrip Adjustment

94. ROOF SIDE RAIL WEATHERSTRIP ADJUSTMENT

After the roof side rails have been aligned, inspect the side rail weatherstrip to make sure it is providing a good seal at the top of the door and quarter glass.

If the weatherstrip is not sealing properly, the retainer and weatherstrip can be adjusted to improve the seal. The retainer has elongated attaching screw holes which permit the retainer and weatherstrip to be moved in or out (Fig. 90).

To adjust the seal fit along the edge of the glass, loosen the retainer screws under the weatherstrip and adjust the retainer, as required.

Raise the glass until the top edge of the glass curls the outer lip of the weatherstrip inward just enough to contact the inner lip. Adjust the up-stops to limit further upward travel of the glass.

95. REAR BOW TENSION CABLES

Two steel cables attached to the rear bow and the top well are provided to keep the bow from moving

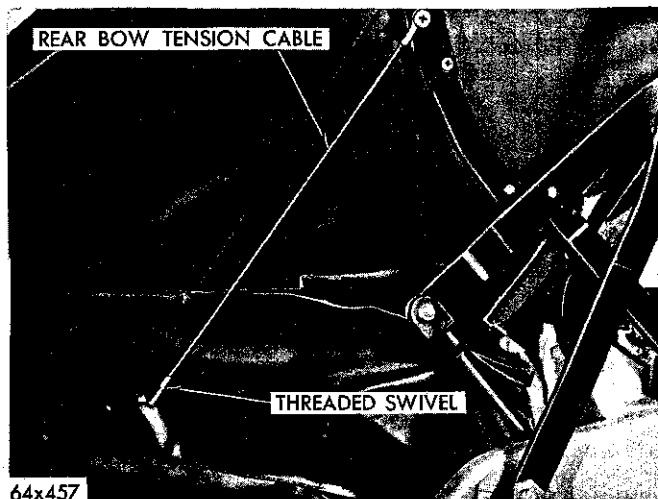

Fig. 91—Rear Bow Tension Cable

forward and wrinkling the top material. They also prevent excessive tension on the backlight zipper. The upper end of the cables are attached to the bow by screws. The lower end is threaded into a clinch nut attached to a bracket at the top well which permits the cables to be shortened or lengthened to increase or decrease tension (Fig. 91). The degree of tension is determined from a measurement taken between the lower rear edge of the bow and the ledge of the top well under the backlight.

Before attempting to adjust the cables, unfasten the top header latches to relieve tension on the linkage.

REAR BOW TENSION CABLE CHART

Model	Each Side of	
	Centerline (Inches)	Bow to Ledge (Inches)
Chrysler.....	20	27¼
Imperial.....	20	24½

Testing Cable Adjustment

On the inside of the car, locate the centerline of the top on the rear bow and the ledge of the top well. From the centerline, measure the specified distances (refer to the rear bow tension cable chart), each side of the centerline at the bow and the ledge. These are locating points for backlight depth dimensions that govern the cable tension.

Measure down from the rear edge of the rear bow to the top well ledge on each side.

If the spacings between the bow and the ledge are not to specifications, the cables must be adjusted. With an assistant holding a tape measure at one location, remove one cable attaching screw. While holding the top bow in the measured position, turn the upper end of the cable in the proper direction until the eye of the cable is in line with the screw hole. Install the screw. Repeat the procedure, if required, on the opposite cable.

96. CORRECTING THE WRINKLES IN THE BACKLIGHT

Cable adjustment may cause wrinkles in the backlight area. To correct this condition, it will be necessary to remove the mouldings and retainers and relocate the backlight and quarter trim.

Before removing the moulding screws, place a strip of masking tape on the deck, directly behind the mouldings. Mark the screw locations on the tape to aid in reassembly.

Remove the moulding screws, moulding, retainer screws and retainer. Restretch the backlight and

quarter trim to remove the wrinkles. Trim off excess backlight and quarter trim material that extends beyond the retainer. Reinstall the retainers and mouldings.

97. CORRECTING TOP WELL WATER LEAK (Chrysler Models)

Water leaking into the top well may be entering between the lower edge of the backlight and the deck opening upper panel. To correct, seal the area with body sealer and a polyethylene foam seal. Apply a strip of masking tape on the deck panel directly to the rear of the finish moulding to facilitate the installation of the retainer and moulding screws.

Remove the moulding and retainer screws. Lift off the mouldings, retainers and top material from the deck panel. Carefully clean the deck panel surface. Spread a bead of body sealer along the edge of the panel. Place the top well material back in position on the sealer. Position a 104-inch x 5/8-inch wide x 1/8-inch polyethylene foam seal on the top material.

Install the retainers. Install an additional No. 8, self-tapping screw with a plain washer through the top material and deck panel, midway between the center and end retainers to provide a tight seal. Install the mouldings. Water test the area and inspect for leaks.

98. SERVICING THE TOP FOLDING MECHANISM

The electric-hydraulic top folding mechanism, Figure 92 consists of two cylinders, a piping system, an electric motor, a pump and reservoir assembly,

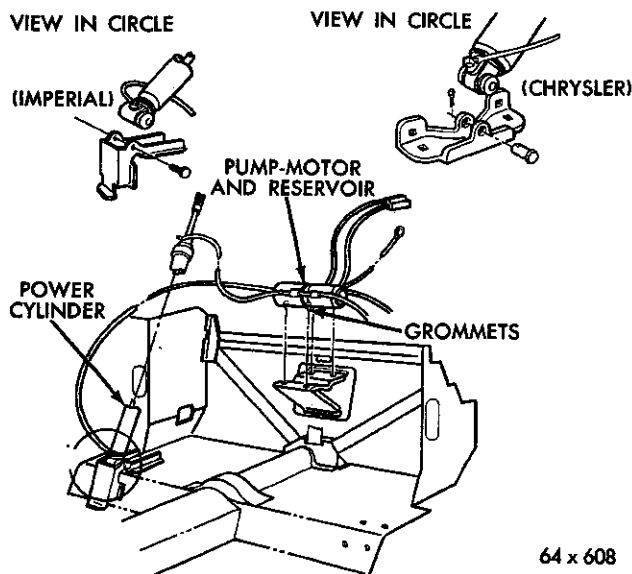

Fig. 92—Convertible Top Hydraulic Mechanism

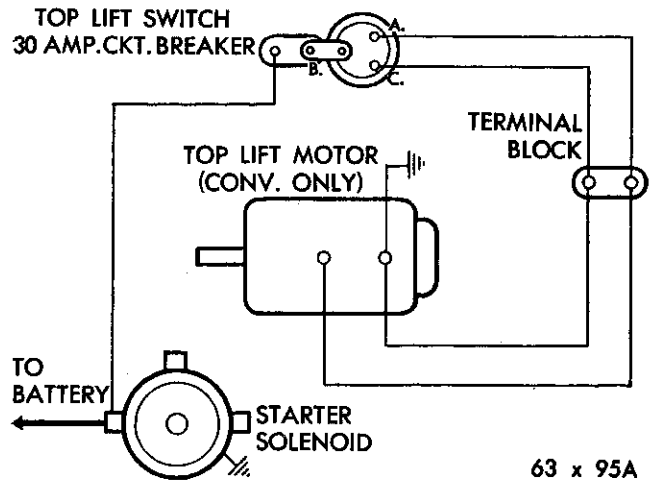

Fig. 93—Convertible Top Wiring Diagram

and a double-throw rotary switch. The wiring and motor are protected by a separate circuit breaker, as shown in Figure 93.

The pump is a two-direction, reversing motor type and is connected to the cylinders by flexible lines and tubing. A valve and port assembly in the reservoir directs flow of fluid in the system. The motor, pump, and reservoir assembly can be replaced as a unit, or the electric motor can be replaced separately. The cylinders are sealed units and must be replaced as assemblies. If difficulty is encountered in raising or lowering the top with the motor running, with sufficient fluid in the reservoir, and again with the pivot points operating freely without binding, the cause is probably improper linkage alignment and adjustment.

99. FLUID LEVEL IN RESERVOIR

Insufficient fluid in the system may cause the top to raise slowly or cause noise in the pump and motor during the operation. Measure the fluid level in the reservoir. If low, look for a leak due to a broken line or a loose connection. Replace the line or tighten the connection as necessary. Fill the reservoir until the fluid runs out of the filler holes. Use type "A" suffix "A" automatic transmission fluid.

NOTE: After filling the reservoir, raise and lower the top several times to force out air that may be trapped in the system. Always measure the fluid level when the top is lowered.

100. TOP WILL NOT RAISE OR LOWER

Hook one wire of a test lamp to a good ground and the other wire of the test lamp feed to the terminal on the control switch. The test lamp should light. If the test lamp does not light, test on each side of the circuit breaker, as necessary.

101. TESTING THE TOP CONTROL SWITCH

Disconnect the black wire at the top control switch and hold it firmly against the black and red wire terminal on the control switch. The top (if raised) should start to lower. Repeat this test with a green wire. The top (in the lowered position) should start to rise. If the top operates during these tests, but fails to operate when the control switch lever is moved to right or left, the switch is at fault and should be replaced. If the top fails to operate during these tests, follow the procedure outlined for "Adjusting the Top", "Checking the Fluid Level in the Reservoir and Testing the Wires between the Control Switch and the Pump Motor.

102. TESTING WIRES BETWEEN THE CONTROL SWITCH AND PUMP MOTOR

This test can be made from the luggage compartment. Inspect the pump motor ground wire (black wire between the pump motor and the ground) to make certain it has a good, clean ground connection. Connect one wire of a test lamp to the black wire terminal on the pump motor and ground the other wire of the test lamp. Move the top control lever to the right. Test test lamp should light. If the test lamp does not light, the black wire between the pump motor and the control switch is faulty and should be

replaced. Repeat this test at the green wire terminal, moving the top control lever to the left. If the test lamp lights in both cases, but the pump motor fails to operate, replace the pump motor.

103. REAR WINDOW (Convertible Coupe)

The rear window is made from flexible vinyl plastic material and special attention should be given to cleaning and storage of the window. To clean the window, rinse with a cold water spray to remove grit and dirt. Lather the surface with suds of a mild soap (such as Castile), using the palm of the hand. Rinse thoroughly and allow to air dry. Do not use a towel, sponge, or chamois to apply suds or to dry the window. Otherwise, the surface may become scratched. If this procedure does not clean the window thoroughly, a solution of 40 per cent rubbing alcohol and 60 per cent clean water should be used. Apply with palm of hand and rub surface of window with a circular motion. Use the solution generously.

104. CARE AND CLEANING OF TOP

Frequent brushing and vacuuming will keep the top free of abrasive dust and dirt. Wash the top with warm water and mild soap, lathering well with a soft cloth or sponge. Rinse with plenty of clean water to remove all traces of soap. Allow to dry completely before lowering.

PART 7

TOWN AND COUNTRY

105. TAIL GATE

The tail gate of the Chrysler Town and Country is hinged at the lower corners and is counter-balanced by a single torsion bar to aid in raising and lowering. The 3 seat Town and Country is equipped with an electric window which is optional on the other models. The electric window is controlled by a switch on the instrument panel. An externally operated lock cylinder switch provides for external operation of the window.

A squeeze and pull type handle is located in the center of the upper inside garnish moulding to unlatch the tail gate. The tail gate is held closed by two rotary type locks mounted on the sides of the tail gate. These rotary locks engage two-stage strikers attached to the pillar post.

Removal (Tail Gate)

(1) Remove the rear bumper face bar to enable the tail gate to be removed down and out of the body opening.

(2) Under the tail gate door, remove the torsion bar brackets from the pillar posts.

(3) Open the tail gate and support on jacks or stands.

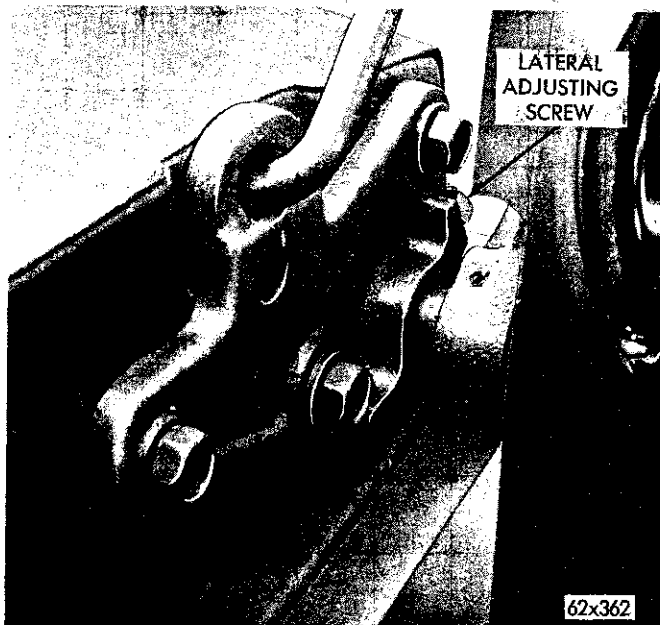

Fig. 94—Torsion Bar Hinge and Aligning Points

(4) Loosen the hinge pivot pin locking screws (Fig. 94).

(5) Use a pencil and outline the hinge plate position on pillar post for future assembly.

NOTE: On vehicles with an electric window, disconnect the battery and remove the trim panel and disconnect the terminals at the control switch on the left edge of the tail gate.

(6) Remove the hinge plate attaching bolts from the pillar post.

(7) Slide the hinge plate and the torsion bar in through the guide toward the center of the tail gate.

(8) Lower the tail gate down and out of the body opening.

Installation (Tail Gate)

(1) With the torsion bar and hinge plates pushed in toward the center of the tail gate, engage the hinge plates into the lower opening of body.

(2) Attach the hinge plate attaching bolts into the pillar posts and locate the hinge plates in relation to the previous pencil marked positions.

(3) Tighten the attaching bolt firmly enough to hold the position and check the alignment.

(4) Close the tail gate and center in opening.

(5) Attach the torsion bar bracket to the pillar post.

(6) Open the tail gate and tighten the locking screws on the hinge pivot pin.

(7) Connect the wires to the control switch and install the trim panel.

(8) Operate the tail gate window and check for alignment.

106. TAIL GATE GLASS

Removal

(1) Lower the tail gate glass and open the tail gate.

(2) Remove the attaching screws and remove the garnish moulding and the handle.

(3) Remove the inside trim panel.

(4) With an assistant operating the instrument panel control switch, support the glass as it emerges.

(5) Remove the retaining clips and the regulator arms from the window frame and remove the glass from the tail gate.

Installation

(1) Insert the glass into the tail gate run channels deep enough to engage the regulator arms into the window frame.

(2) Install the inside trim panel.

(3) Install the garnish moulding and the handle.

(4) Operate the window and inspect for misalignment.

107. TAIL GATE GLASS RUN CHANNEL**Removal**

(1) With the tail gate glass removed, remove the channel attaching bolts and remove the channel.

Installation

(1) Position run glass channel into the tail gate and install the attaching bolts only finger tight.

(2) Install the tail gate glass into the run channel and engage the regulator arms and install the retaining clips.

Adjustment

(1) Run the tail gate glass to the bottom stop and close the tail gate.

(2) Operate the glass up and down several times to center or position the run channel.

(3) Tighten the run channel attaching bolts and reinstall the trim panel, the garnish moulding and the handle.

Tail Gate Glass Adjustment

(1) Remove the tail gate inside trim panel.

(2) Loosen the lower run channel attaching screws.

(3) Close the tail gate and run the glass to the mid-way position.

(4) Tighten the lower run channel attaching screws.

(5) Run the glass to within one-half inch of the top seal and check the level of the glass in relation to the top weather seal (To level the glass, loosen the regulator attaching screws and raise or lower one end of the regulator to align the glass. Retighten the regulator screws).

(6) Tighten the top screws of the lower run channel.

(7) Operate the glass several times to check ease of operation and also the position of the glass down stops (The glass should be level or slightly lower than the belt line of the tail gate).

(8) Install the tail gate inside trim panel.

108. FOLDING THIRD SEAT

The folding third seat and seat back are adjustable

to assure a level floor condition when in a closed position. The seat and seat back may also be removed to provide additional cargo space by removing the hinge bracket attaching bolts.

109. QUARTER GLASS**Removal**

(1) Remove the inside garnish mouldings.

(2) Remove the outside moulding attaching screw from the lower rear corner of the quarter glass.

(3) Insert a tapered fiber stick between the window fence and the weatherstrip and loosen the weatherstrip from the body.

(4) With an assistant to hold the glass from outside, press the glass from the lower rear corner and remove the glass, weatherstrip and moulding assembly from the window opening.

(5) Bend up the attaching tabs of both the upper and lower corner moulding caps and remove the moulding from the weatherstrip.

(6) Roll the weatherstrip off of the glass.

Installation

(1) Inspect the weatherstrip for tears, cuts or distortion.

(2) Apply a small coat of weathersealing cement to the edge of the glass and starting at the front corner, roll the weatherstrip onto the glass.

(3) Starting at the front upper corner of the weatherstrip, work the trim moulding into the groove of the weatherstrip.

(4) Install the front corner moulding cap and insert the attaching tab through slot of weatherstrip and bend under.

(5) Install the lower moulding.

(6) Install the rear corner moulding cap and insert the attaching tab through slot in weatherstrip.

(7) Place the glass, weatherstrip and moulding assembly on a padded table with inside of glass up.

(8) Starting at the lower center of the weatherstrip insert a pull-cord in the flange groove with the ends of the cord crossed.

(9) With an assistant holding the glass, weatherstrip and moulding assembly in approximate position in the window opening, slowly work the weatherstrip over the window fence by pulling the cord.

(10) Position the glass into place by bumping glass with the palm of the hand.

(11) Install the rear corner moulding attaching screw.

(12) Install the inside garnish mouldings.

**110. POWER WINDOWS
(Vent Wing, Door, Quarter Glass
and Tail Gate)**

Imperial vehicles are equipped with power windows as standard equipment. They are also offered as optional equipment on Chrysler models.

The windows are operated electrically by a master switch located in the left door panel. The windows may also be operated by individual switches located in the upholstery panels adjacent to the glass they operate. The glass adjustments remain the same as the manual operated glass.

111. TAIL GATE GLASS

Adjust the glass for proper fit. Be sure to adjust lift so that when glass is raised it fits squarely into top channel and compresses against the glass run. If glass does not seat in run when in closed position, it is possible for dust, water and carbon monoxide gas to be pulled in and around top of glass.

112. TAIL GATE WEATHERSTRIP

The tail gate weatherstrip is designed to fit under a lip and into a channel at the sides of the tail gate opening. At its upper end a piece extends out and fits up into the bottom of the pillar (Fig. 95). Remove all weatherstrip that is not installed properly. Clean the channel and the weatherstrip with cement removing solvent. Apply a coat of cement to each part and reinstall weatherstrip. At the bottom of opening, it is sometimes necessary to remove the weatherstrip and after cleaning shim the weatherstrip surfaces and reinstall.

113. TAIL GATE SEALING

Sealing procedures pertaining to the roof, cowl, firewall, fresh air vent, doors and openings are essentially the same as contained in the section devoted to the sedans and coupe models.

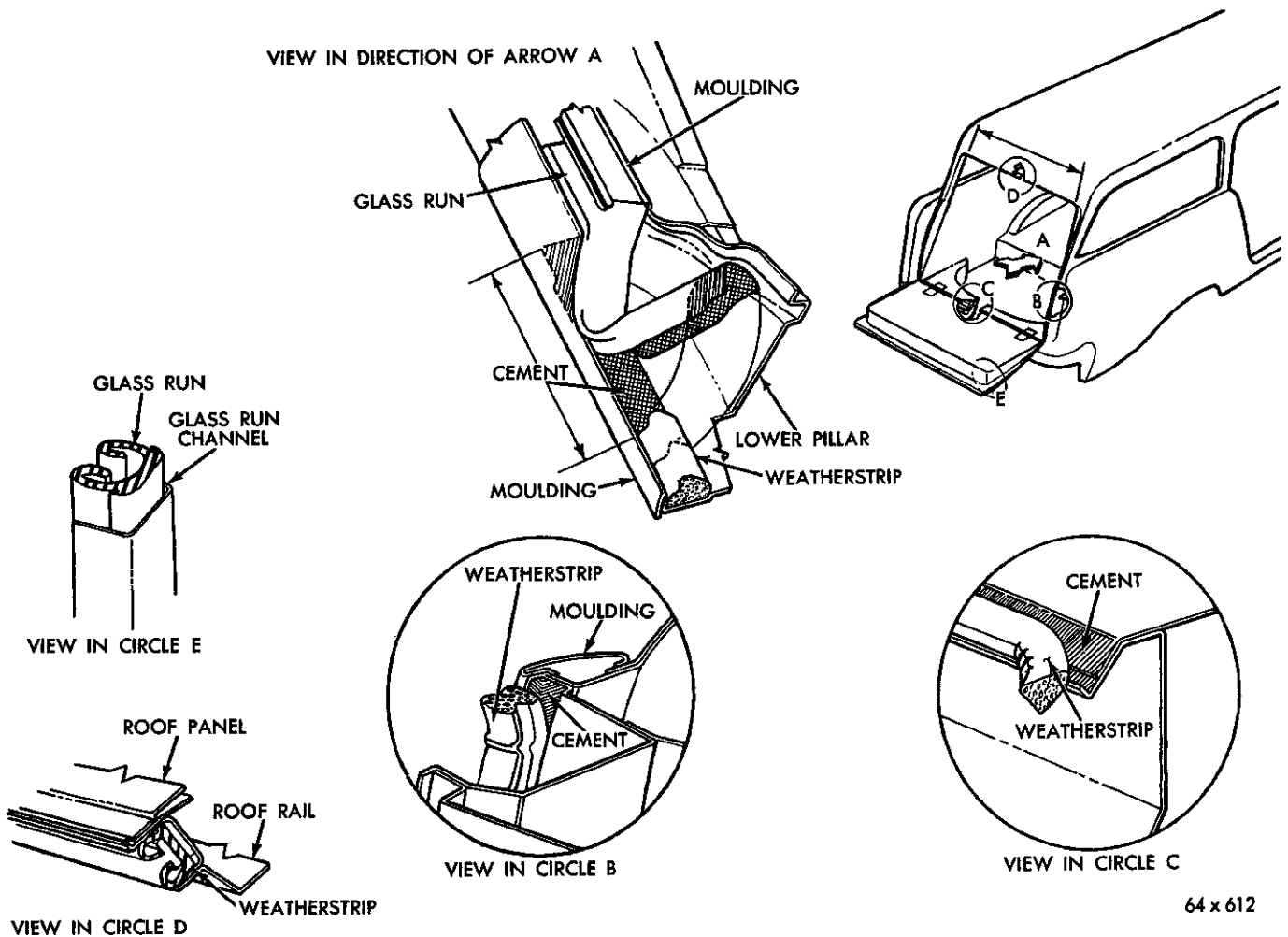

64 x 612

Fig. 95—Town and Country Tail Gate Seating

114. TAIL GATE GLASS RUN CHANNEL LEAKAGE

Water leaking past the glass run around the channel may be sealed off (Fig. 95) by applying sealer at indicated points. Water leaking around glass run may be sealed by removing glass run and applying additional beads of sealer to the glass run channel. Press a bead of rope-type seal into moulding seams and clean off surplus. While rear pillar garnish moulding is removed, inspect the outer "D" shaped

opening; seal if necessary. This opening should be filled with caulking putty.

115. TAIL LAMPS

Water test tail lamp area for possible leakage into the luggage compartment. Water may enter between the tail lamp housing and quarter panel openings. To obtain a good seal, use a body caulking compound and the tail lamp should be removed, resealed and reassembled.

PART 8
SERVICE DIAGNOSIS

MANUAL DOOR LOCK AND LINKAGE

Condition	Possible Cause	Correction
Door Hard to Open Sticks	<ul style="list-style-type: none"> (a) Striker rubbing on the door face or on the back rotor housing. (b) Lock striker not set at the correct angle or position. 	<ul style="list-style-type: none"> (a) Add or remove shims in back of the striker to remove the interference. (b) Adjust the striker so that the top of the lock housing moves parallel to the bottom surface of the striker teeth and the door is not raised or pulled down as the lock engages the striker. (c) Relocate the moulding being sure the screw heads do not project.
Door is Hard to Close	<ul style="list-style-type: none"> (a) Door weatherstrips have high spots or other crowded conditions when the door is in the proper closed condition. (b) Door rubber bumpers too thick. (c) Upper and lower hinges improperly aligned or lack lubrication. (d) Striker not properly adjusted. (e) Excessive side glass interference with roof rail weatherstrip. (f) Excessive door upper frame (Imperial interference with roof rail.) 	<ul style="list-style-type: none"> (a) Correctly shim or adjust the weatherstrips. Re-cement wherever necessary. (b) Cut the bumpers down if they are too thick. (c) Adjust and lubricate the hinges using MoPar Lubriplate. (d) Adjust the striker so the lock engages in the second position when the door surface is flush with the pillar or adjoining sheet metal. (e) Readjust the door glass to reduce interference with the roof rail but still maintaining the proper seal. (f) Readjust the door upper frame (Imperial) to reduce interference but retain seal.
Outside Handle Does Not Return	<ul style="list-style-type: none"> (a) Handle interferes with the escutcheon. (b) Handle is free but does not return freely due to broken spring. (c) Handle sluggish but shows no interference in the handle mechanism and the spring is operating correctly after removing the handle to lock link. 	<ul style="list-style-type: none"> (a) Insert a screwdriver between the handle and escutcheon and pry in the desired direction to relieve the interference. (b) Replace the handle. (c) Inspect the lock mechanism for proper lubrication. Lubricate with MoPar Lubriplate. Test for interference in the pivot and spring of the lock release and links.
Remote Control Handle Does Not Return to the Neutral Position	<ul style="list-style-type: none"> (a) Interference between the remote control handle and the slot in the arm rest. (b) Interference between the trim panel and the hub of the remote control handle. Test by pressing the trim panel away from the remote control handle. 	<ul style="list-style-type: none"> (a) Adjust the trim panel to provide proper clearance. (b) Remove the tapered coil spring from the remote control handle shaft.

SERVICE DIAGNOSIS— (Continued)
MANUAL DOOR LOCK AND LINKAGE

Condition	Possible Cause	Correction
	(c) Interference in the remote control mechanism.	(c) Inspect for an excessively tight anti-rattle clip on the inner panel at the middle of the remote to lock link. Properly lubricate the remote control mechanism and the lock assembly, using MoPar Lubriplate.
Outside Handle Does Not Release the Lock	(a) Lock adjustment set too high. (b) Outside handle to lock link disconnected.	(a) Properly adjust the lock adjusting screw. (b) Be sure the flattened end of the link is not too wide spreading the clip. File the edge of the flat so the clip fits freely. Install the link.
	(c) Ineffective release lever spring or damaged transmitter or detent actuator.	(c) Install a new lock.
Inside Handle Does Not Release Lock on Front Doors	(a) Remote control assembly improperly adjusted.	(a) Adjust the control mechanism until it will completely lock and release the lock.
Inside Handle Does Not Release the Lock on the Rear Doors	(a) Remote control assembly improperly adjusted.	(a) Loosen the remote control assembly attaching screws and, with the lock locked, move the remote control assembly forward as far as possible without forcing or bending the lock to control link. Tighten the remote control assembly attaching screws.
Door Lock Does Not Hold Door Closed (False Latching)	(a) The rotor pawl or lever may be jammed or bent.	(a) Install a new lock.
The Whole Door Rattles or Moves Excessively When Driving	(a) Door rubber bumpers missing on back of door flanges or pillars. (b) Improperly adjusted lock striker. (c) Loose rotor. (d) Welds broken and rotor cover loose.	(a) Install the bumpers where required. (b) Adjust the striker. (c) Re-rivet inside and outside rotors. Install a new lock if damaged. (d) Install a new lock.

VACUUM DOOR LOCKS

Vacuum Door Lock System is Inoperative	(a) Main vacuum feed hose is pinched or blocked. (b) Manifold to vacuum tank hose disconnected. (c) Vacuum tank to vacuum distributor hose disconnected.	(a) Inspect the main vacuum hoses from the intake manifold to the vacuum tank, and from the vacuum tank to the vacuum distributor. Inspect the hoses for short bends, kinks, or being pinched. Correct as required. Install new hoses if necessary. (b) Connect the manifold to the vacuum tank hose. (c) Connect the vacuum tank to the distributor hose.
---	--	--

SERVICE DIAGNOSIS— (Continued)
VACUUM DOOR LOCKS

Condition	Possible Cause	Correction
	(d) Vacuum distributor to control switch hose disconnected.	(d) Connect the vacuum distributor to the control switch hose. Be sure the hose marked "white" connects to the large diameter fitting marked "white" on the switch.
	(e) Vacuum distributor to main tee hose disconnected.	(e) Connect the vacuum distributor to main tee hoses, according to the color code of the hoses and fittings.
	(f) Malfunctioning or faulty switch.	(f) Remove the small diameter hoses from the switch. Start the engine, and operate the control switch. If there is no vacuum at the switch connections, the switch is at fault. Install a new switch.
	(g) Faulty vacuum distributor.	(g) Remove the distributor to main tee hose from the distributor connection. Start the engine. Operate the switch to "lock" and "unlock" positions. If no vacuum at the connections, the distributor is at fault. Install new distributor.
Vacuum Door Lock System Fails to Lock. (Manual Operation Satisfactory. Vacuum Unlock Operation Satisfactory.)	(a) Hose with "red" marking disconnected at the switch.	(a) Connect the hose with the "red" marking to the switch fitting marked "red".
	(b) Hose with "red" marking disconnected at the vacuum distributor.	(b) Connect the hose with the "red" marking to the distributor fitting marked "red".
	(c) Faulty control switch.	(c) Disconnect the hose with the "red" marking at the switch. Start the engine. Move the control switch to the lock position. If no vacuum is felt at the "red" connection, the switch is at fault. Install a new switch.
	(d) Faulty vacuum distributor. (Lock valve stuck.)	(d) Remove the distributor to main tee hose marked "red", from the distributor connection. Start the engine. Operate the switch to the "lock" position. If no vacuum is felt at the connection, the distributor is at fault. Install a new distributor.
	(e) Hose disconnected at any fitting in the "red" hose system to the actuator.	(e) Inspect all the connections in the "red" hose system to the actuator.
	(f) Leak in hose to door.	(f) Install a new hose.
	(g) Broken hose connector on the actuator.	(g) Remove the door inside trim panel. Inspect the actuator. Install a new actuator if the connector is broken.
Vacuum Door Lock Systems Fails to Unlock. (Manual Operation Satisfactory. Vacuum "Lock" Operation Satisfactory.)	(a) Hose disconnected at the control switch.	(a) Connect the hose at the switch.
	(b) Hose disconnected at the vacuum distributor.	(b) Connect the hose at the vacuum distributor.
	(c) Faulty control switch.	(c) Disconnect the hose with no marking at the switch. Start the engine. Move the control switch to the "unlock" position. If no vacuum can be felt at the connector, the switch is at fault. Install a new switch.

SERVICE DIAGNOSIS—(Continued)
VACUUM DOOR LOCKS

Condition	Possible Cause	Correction
	(d) Faulty vacuum distributor. (Unlock valve stuck.)	(d) Remove the distributor to main tee "unmarked" hose from the distributor connection; start the engine. Operate the switch to the "unlock" position. If no vacuum is felt at the connection, the distributor is at fault. Install a new distributor.
	(e) Hose disconnected at any fitting in the "unmarked" hose system to the actuator.	(e) Inspect all the hoses in the "unmarked" hose system to the actuator.
	(f) Leak in the hose to the door.	(f) Install a new hose.
	(g) Broken hose connector on the actuator.	(g) Remove the door inside trim panel. Inspect the actuator. Install a new actuator if the connector is broken.
Door Locks Operate Opposite to That of the Switch Operation	(a) Small hoses reversed on the control switch. (b) Hoses reversed at the distributor connections. (c) Control switch mounted in reverse position.	(a) Connect the hoses correctly. (b) Connect the hoses correctly at the distributor. (c) Install and correctly connect the switch.
Doors on One Side Lock, While the Doors on the Opposite Side Unlock.	(a) Door hose lines incorrectly connected to the tee at the cowl side panels.	(a) Correctly connect the hoses.
One Door Lock Operates Opposite to the Lock of the Other Doors	(a) Hoses improperly connected to the tee at the cowl side panel. (b) Hoses improperly connected at the door lock actuator.	(a) Connect the hoses correctly. (b) Connect the hoses at the actuator correctly.
One Door Vacuum Lock Fails to Operate. (Manual Operation Satisfactory.)	(a) Binding or malfunctioning door lock actuator linkage. (b) Faulty actuator.	(a) Remove the door inside trim panel. Inspect the actuator and linkage, correct as required. (b) Remove the door inside trim panel. Inspect the actuator and linkage. Install a new actuator if necessary.

CONVERTIBLE COUPE TOP

Folding Top Header and Windshield Header Not Meeting at Correct Angle	(a) Incorrect front and rear side rail adjustment.	(a) With the top in the up position and the header locked in, turn the square head screw at the front side rail hinge and the set screw at the rear side rail hinge until they contact the head.
"Jack Knifing" of the Side Rails at the Rail Hinges	(a) Improper alignment of the side rails to the top of the window glass.	(a) Adjust by moving the serrated adjustment plate up or down to hold the side rails in their correct relationship to the window frame. Adjust both sides to the same height to maintain parallelism of the side rails.

**SERVICE DIAGNOSIS—(Continued)
 CONVERTIBLE COUPE TOP**

Condition	Possible Cause	Correction
Improper Meeting (Fore and Aft) of the Folding Top Header With the Windshield Header	(a) Improper adjustment of the power link.	(a) Adjust the power link "fore and aft" across the serrated plate. Adjustment is in direction of movement desired.
Folding Top Header Not in Alignment With the Guide Dowels on the Windshield Header	(a) Improper adjustment of the folding header.	(a) Adjust the folding top header "fore and aft" until alignment with the guide dowels is accomplished.
Top Fabric Too Loose or Too Tight	(a) Improper adjustment of the number 1 roof bow.	(a) Adjust the roof bow up or down on the bow support.
Air or Water Leaks at the Windshield Header	(a) Folding top header torsion bar not properly adjusted.	(a) Adjust the folding top header torsion bar to accomplish a 30 pound locking handle effort.

1