

GROUP 6 - CLUTCH

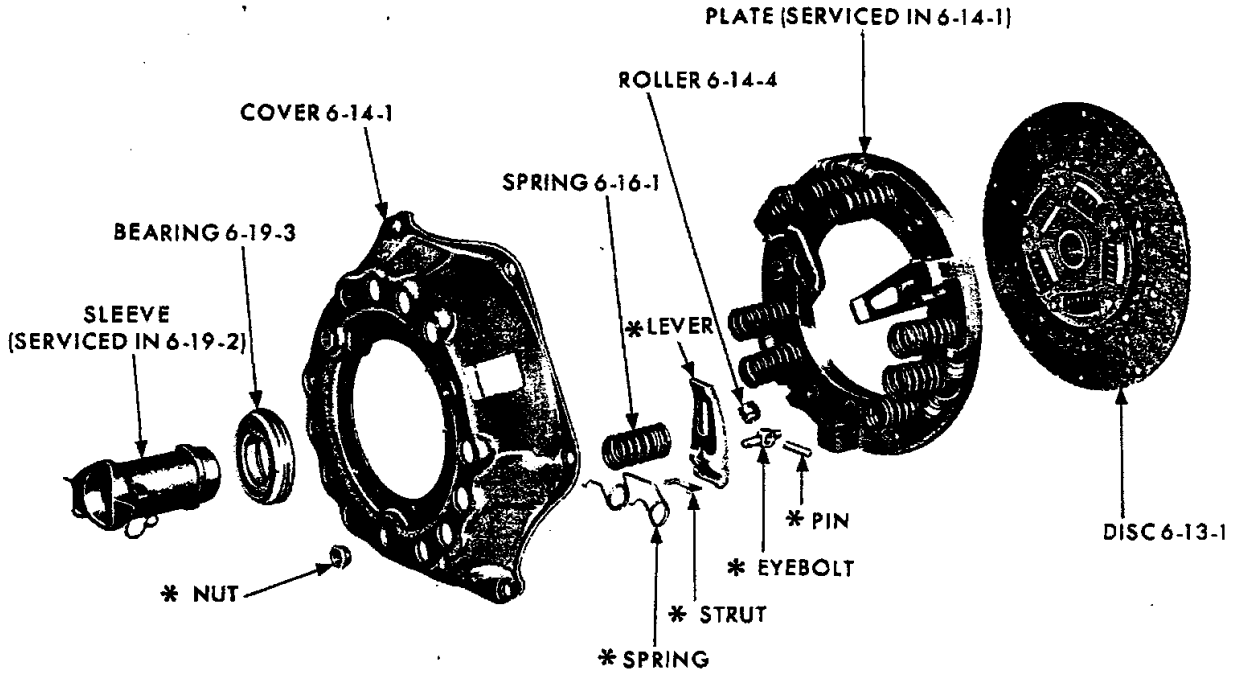

* SERVICED IN LEVER PACKAGE 6-17-3

19x8633C

CLUTCH PRESSURE PLATE AND DISC

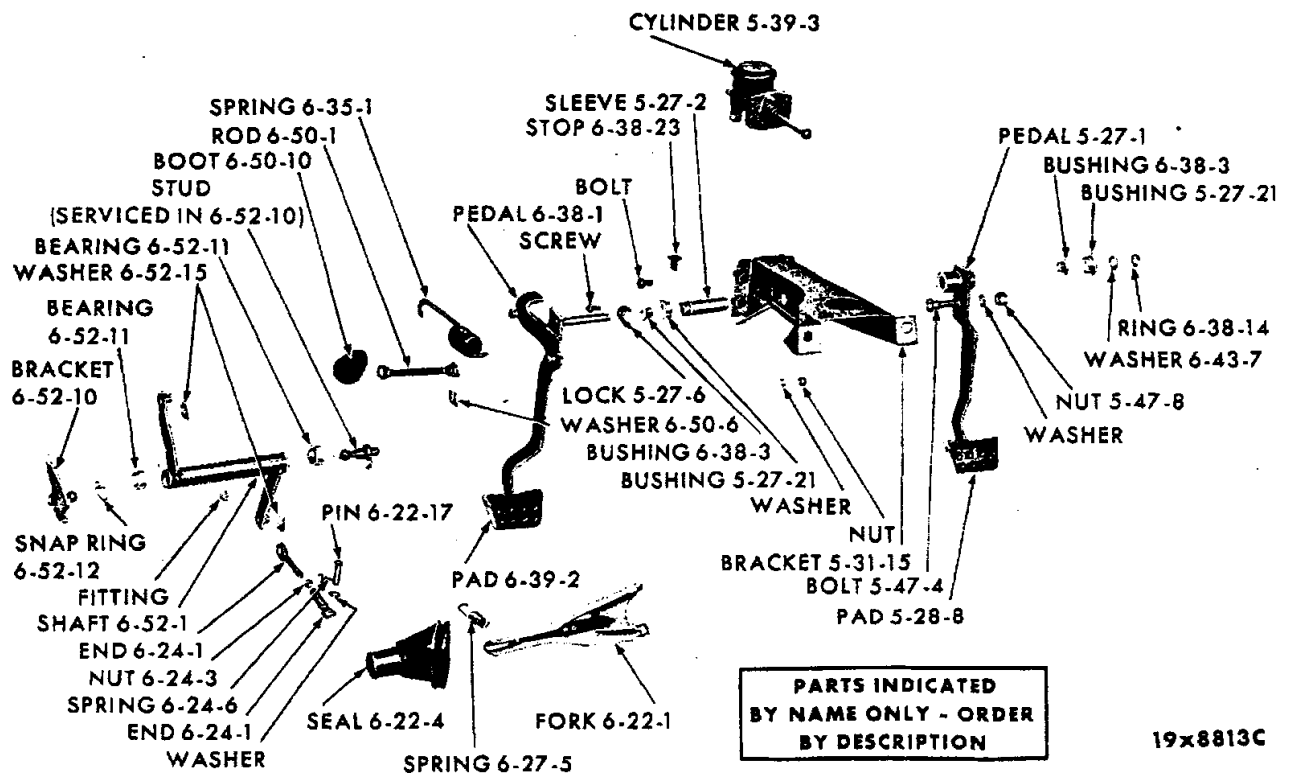

PARTS INDICATED BY NAME ONLY - ORDER BY DESCRIPTION

19x8813C

CLUTCH AND BRAKE PEDAL LINKAGE - VALIANT VV1-2 AND DART VL1-2 (WITH MANUAL TRANSMISSION)

19x9314B

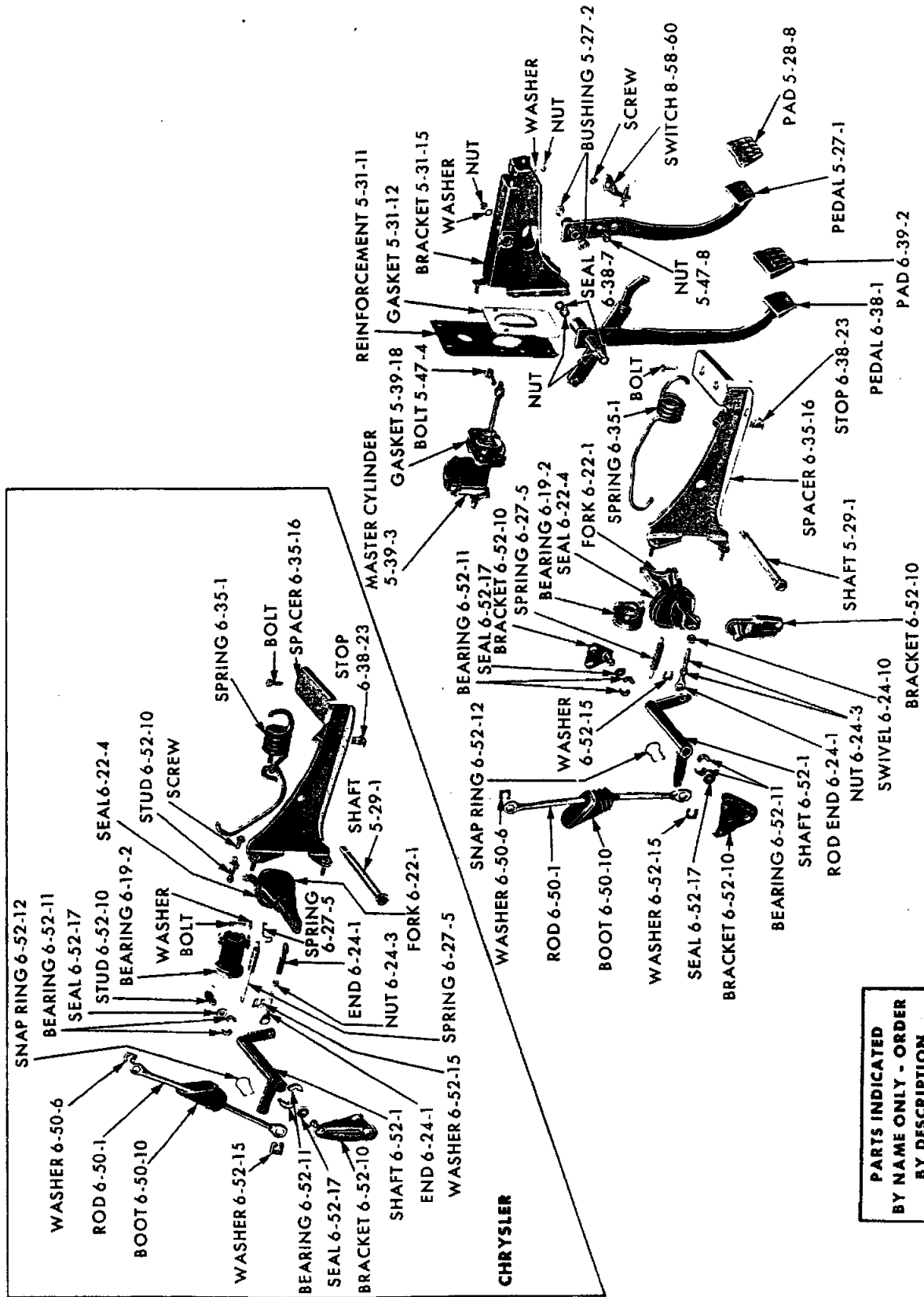

PARTS INDICATED BY NAME ONLY - ORDER BY DESCRIPTION

CLUTCH AND BRAKE PEDAL LINKAGE - PLYMOUTH VP1-2, DODGE VDI-2 AND CHRYSLER VC1-2-3 (WITH MANUAL TRANSMISSION)

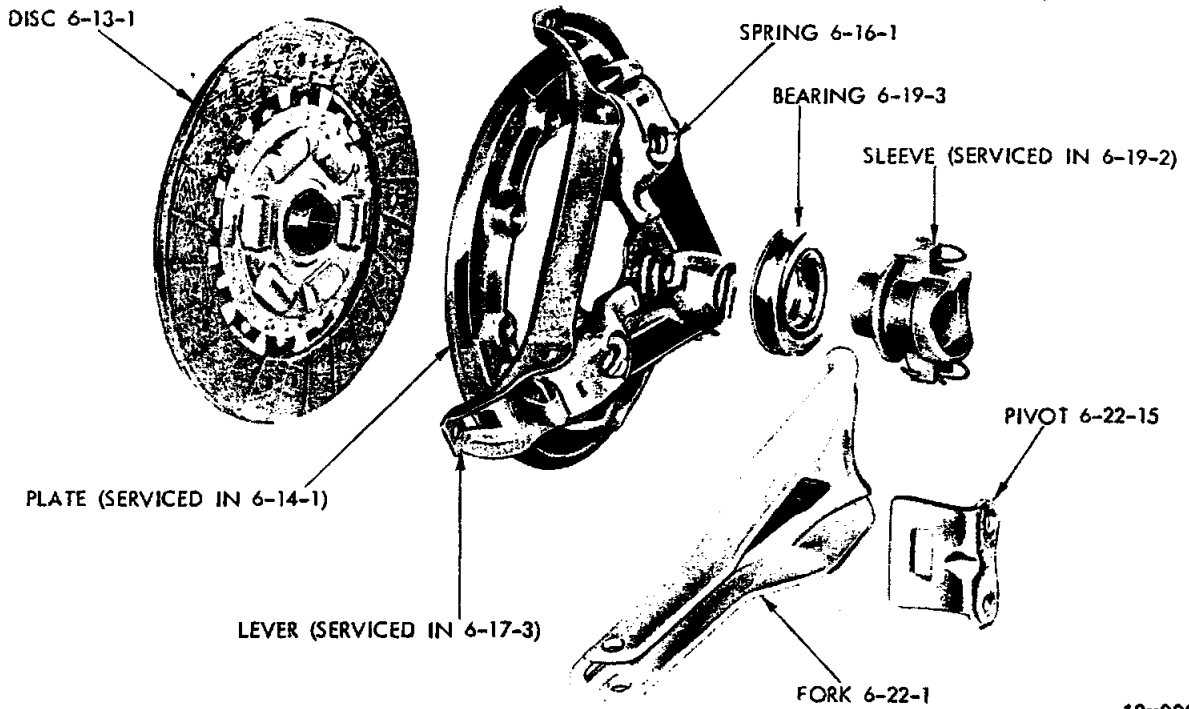

19x9996

CLUTCH - USED WITH 273 CU. IN. ENGINE

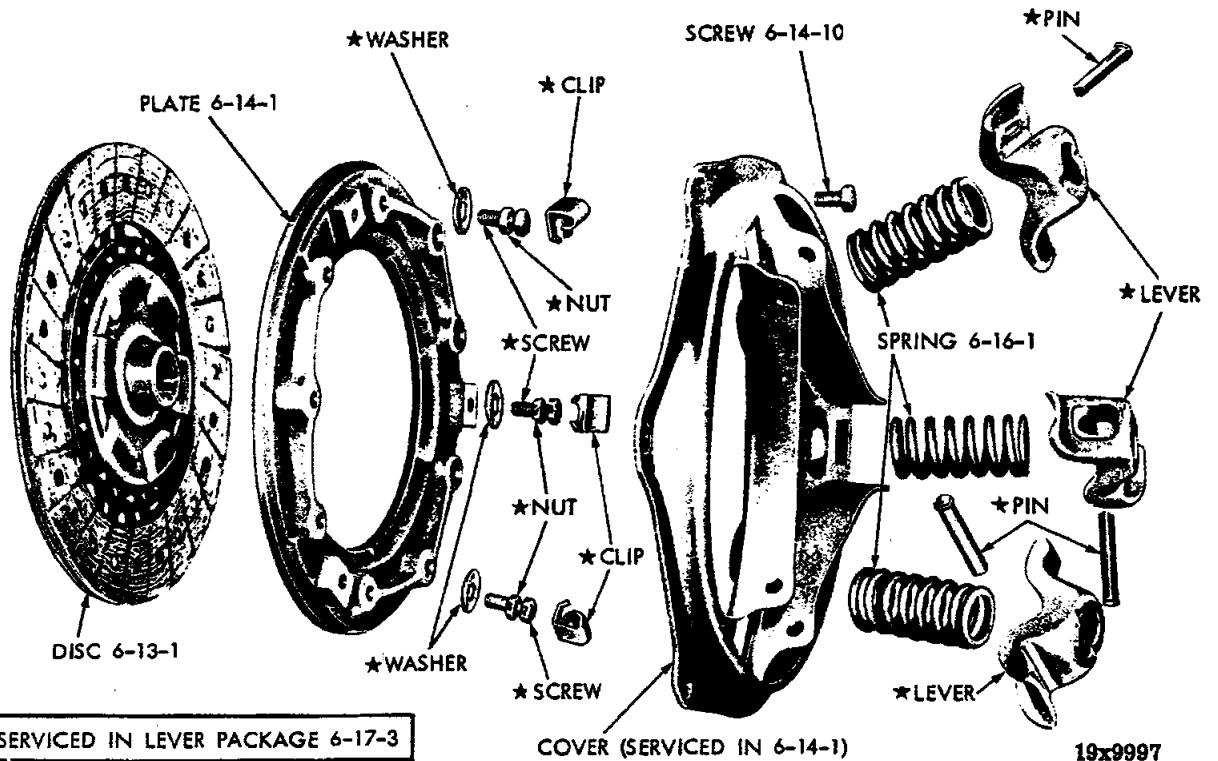

★ SERVICED IN LEVER PACKAGE 6-17-3

19x9997

CLUTCH - 3 SPRING TYPE

CODE	PART NAME AND DESCRIPTION	C Y L	PER CAR	VALIANT DART	PLYMOUTH DODGE	CHRYSLER IMPERIAL
6-01-0 CLUTCH						
6-01-3	CLUTCH PACKAGE, w/170 cu. in. Eng., 9 1/8" Clutch	6	1	2279 893		
	w/225 cu. in. Eng., 9 1/4" Clutch	6	1	2448 372	2448 372	
6-09-0 CLUTCH HOUSING						
6-09-1	HOUSING, w/170, 225 cu. in. Eng.	6	1	2402 690	2402 690	
	w/170, 225 cu. in. Eng. w/4 Speed Trans.	6	1	2463 025	2463 025	
	w/273 cu. in. Eng., 3 Speed Manual Trans.	8	1	2463 411		
	w/273 cu. in. Eng., 4 Speed Manual Trans.	8	1	2465 524		
	w/225 cu. in. Eng., 11" Clutch, Taxi	6	1	----	2483 565	
	w/318 cu. in. Eng.	8	1	----	2402 696	
	w/361, 383 cu. in. Eng., 3 Speed Trans.	8	1	----	*2402 681	
	VA3, VC1, VC2, w/361, 383, 413, cu. in. Eng.	8	1	----	2128 351	2128 351
	w/426 cu. in. Eng., w/3 Speed Manual Trans.	8	1	----	E2406 043	
	VP2, VD2, VA3, VC2, w/426 cu. in. Eng., 4 Speed Trans., Hemispherical	8	1	----	*2463 235	
	VP2, VD2, VA3, VC2, w/361, 383, 413, 426 cu. in. Eng., Std., 4 Speed Manual Trans.	8	1	----	*2463 017	*2463 017
	SCREW, Housing to Block 3/8 x 1 3/8"	8	5	6023 187	6023 187	
6-09-11	STRUT, Housing to Block	6	1	2129 887	2129 887	
	w/318 cu. in. Eng., Right	8	1	----	2204 702	
	SCREW, w/WASHER, 7/16 x 1 1/8"	8	1	----	6023 143	
	WASHER, Lock 7/16"	8	1	----	6023 050	6023 050
6-10-0 CLUTCH HOUSING PAN						
6-10-2	PAN, w/170, 225 cu. in. Eng.	6	1	2129 885	2129 885	
	w/273 cu. in. Eng., w/3 and 4 Speed Trans.	8	1	2463 414		
	w/318 cu. in. Eng.	8	1	----	2128 938	
	w/225 cu. in. Eng., 11" Clutch, Taxi	6	1	----	2483 588	
	VP2, VD2, w/361, 383 cu. in. Eng., VC2 w/413 cu. in. Eng., 3 Speed Trans.	8	1	----	2402 935	2402 935
	VP2, VD2, VA3, VC2, w/361, 383, 413, cu. in. Eng., 4 Speed Manual Trans.	8	1	----	2402 935	2402 935
	w/426 cu. in. Eng., 4 Speed Trans., Std.	8	1	----	*2402 935	
	VP2, VD2, Hemispherical w/4 Speed Trans.	8	1	----	*2406 045	
	VA3, VC1, VC2, w/361, 383, 413, cu. in. Eng.	8	1	----	1739 613	1739 616
6-10-10	SEAL, Clutch Housing Pan	6	1	2129 886	2129 886	
	w/273 cu. in. Eng., 3 and 4 Speed Trans.	8	1	2465 549		
	w/318 cu. in. Eng.	8	1	----	2128 939	
6-10-31	SCREW, Clutch Housing Pan, 5/16 x 11/16"	8	★	1947 953	1947 953	1947 953
	WASHER, w/426 cu. in. Eng.	8	6	----	6023 054	
6-13-0 CLUTCH DISC						
6-13-1	DISC, 9 1/8" Clutch, 170 cu. in. Eng.	6	1	2298 904		
	9 1/4" Clutch, w/170, 225 cu. in. Eng.	6	1	2448 336	2448 336	
	10" Clutch, w/225 cu. in. Eng., VP1, VD1, Police Cars	6	1	*2200 069	*2200 069	
	9 1/2" Clutch, w/273 cu. in. Eng.	8	1	2401 120		
	10" Clutch, w/318 cu. in. Eng.	8	1	----	2200 051	
	10 1/2" Clutch, w/426 cu. in. Eng., 4 Speed Trans., 11.1 Compression ratio, Max. Performance	3	1	----	*2401 097	
	10 1/2" Clutch, w/426 cu. in. Eng., 4 Speed Trans., 12.5 Compression Ratio, Max. Performance	8	1	----	*2409 713	
	10 1/2" Clutch, w/318, 361, 383, 413 and 426 Std. cu. in. Eng.	8	1	----	*2266 232	*2266 232
	11" Clutch, w/413, 383 cu. in. Eng.	8	1	----	2208 273	2208 273
	11" Clutch, w/225 cu. in. Eng., Taxi	6	1	----	2409 683	

★ Indicates use as required.

Numerals in parentheses () refer to notes.

Printed in U.S.A.

☐ Indicates parts not listed in any previous parts book.

Prices and specifications subject to change without notice.

* Indicates change or addition.

CODE	PART NAME AND DESCRIPTION	CYL	PER CAR	VALIANT DART	PLYMOUTH DODGE	CHRYSLER IMPERIAL
6-13-0 CLUTCH DISC - Cont'd						
6-13-4	FACING, Clutch Disc, 9 1/8" Clutch, 170 cu. in. Eng., w/32 Rivet Holes	6	2	2073 684		
	9 1/8" Clutch, 170 cu. in. Eng., w/24 Rivet Holes	6	2	2265 464		
	9 1/4" Clutch, 225 cu. in. Eng., w/32 Rivet Holes	6	2	859 882	859 882	
	9 1/4" Clutch, 225 cu. in. Eng., w/24 Rivet Holes	6	2	1820 454	1820 454	
	9 1/2" Clutch, w/273 cu. in. Eng.	8	1	2401 115		
	10" Clutch, 225 cu. in. Eng., Front	6	1	----	2201 218	
	10" Clutch, 225 cu. in. Eng., Rear	6	1	----	2201 217	
	10" Clutch, 318 cu. in. Eng.	8	2	----	1554 593	
	10 1/2" Clutch, 426 cu. in. Eng.	8	2	----	2401 098	
	10 1/2" Clutch, 318, 361, 383, 413, 426 Std. cu. in. Eng.	8	2	*2266 233	*2266 233	*2266 233
	11" Clutch, 383, 413, cu. in. Eng.	8	2	----	2208 272	2208 272
	11" Clutch, w/225 cu. in. Eng., Taxi	6	2	----	2409 685	
6-13-8	RIVET, Disc, Facing 7/32" lgh., 9/16" dia.		★	660 146	660 146	660 146
	1/4" lgh., 1/8" dia.		★	1313 312	1313 312	
6-14-0 CLUTCH COVER AND PRESSURE PLATE						
6-14-1	COVER, w/PLATE, 9 1/8" Clutch, w/170 cu. in. Eng.	6	1	2298 903		
	9 1/4" Clutch, 170 w/225 cu. in. Eng.	6	1	*2298 518	*2298 518	
	9 1/2" Clutch, w/273 cu. in. Eng.	8	1	2401 118		
	10" Clutch, w/225 cu. in. Eng.	6	1	----	2266 235	
	10" Clutch, w/318 cu. in. Eng.	8	1	----	2122 254	
	10 1/2" Clutch, w/318 cu. in. Eng., 3 Speed Trans.	8	1	----	*2122 255	
	10 1/2" Clutch, VA3, VC1, w/361 cu. in. Eng., Police Cars	8	1	----	2122 255	*2122 255
	10 1/2" Clutch, VA3, w/361 cu. in. Eng., 4 Speed Trans.	8	1	----	2122 255	2122 255
	10 1/2" Clutch, w/426 cu. in. Eng., Std.	8	1	----	*2409 688	
	10 1/2" Clutch, 383, 413 cu. in. Eng.	8	1	----	2409 688	2409 688
	10 1/2" Clutch, w/426 cu. in. Eng., 11.1, 12.5 Compression Ratio, Hemispherical	8	1	----	*2409 712	
	11" Clutch, 383, 413, cu. in. Eng.	8	1	----	2208 274	2208 274
	11" Clutch, 225 cu. in. Eng., Taxi	6	1	----	2409 682	
6-14-4	ROLLER, Centrifugal	8	1	----	2122 262	2122 262
6-14-10	SCREW, Cover to Flywheel, 7/8" x 5/16"	6	6	307 555	307 555	
	1" x 3/8"	8	6	----	314 926	314 926
	13/16" x 5/16"	6	6	----	2200 050	2200 050
6-16-0 CLUTCH PRESSURE SPRING						
6-16-1	SPRING, w/9 Black Coils		★	2266 239		
	8 3/8 Red Striped Coils		★	2208 268	2208 268	
	8 Red Coils	6	★	*2530 379	*2530 379	
	6 3/4 White Coils		★	1406 504	1406 504	1406 504
	7 1/4 Red Coils		★	1067 037	1067 037	1067 037
	7 3/4 Orange Coils		★	864 397	* 864 397	* 864 397
	7 3/4 Tan Coils		★	----	866 591	866 591
	7 Light Green Coils	8	3	2409 675		
6-17-0 CLUTCH RELEASE LEVER						
6-17-3	LEVER PACKAGE, 9 1/8" Clutch, w/6 Spring Pressure Plate	6	1	2279 894		
	9 1/8, 9 1/4" Clutch, w/3 Spring Pressure Plate	6	1	2298 909	2298 909	
	9 1/4" Clutch, w/9 Spring Pressure Plate	6	1	2240 634	2240 634	
	10", 10 1/2", 11" Clutch, w/9 and 12 Spring Pressure Plate		3	----	*2495 052	*2495 052
	9 1/2" Clutch, 273 cu. in. Eng.	8	1	2525 030		
	10 1/2" Clutch w/426 cu. in. Eng. Std. and Maximum Performance	8	1	----	*2495 052	

★ Indicates use as required.

Numerals in parentheses () refer to notes.

Printed in U.S.A.

☐ Indicates parts not listed in any previous parts book.

Prices and specifications subject to change without notice.

March 15, 1965 Supersedes March 16, 1964.

Page 6-4

* Indicates change or addition.

CODE	PART NAME AND DESCRIPTION	CYL	PER CAR	VALIANT DART	PLYMOUTH DODGE	CHRYSLER IMPERIAL
6-19-0 CLUTCH RELEASE BEARING						
6-19-2	BEARING, w/SLEEVE		1	2405 077	2405 077	
	w/11" Clutch	6	1	----	2461 494	
	VC1, VA3, w/361 and 426 cu. in. Eng., 4 Speed Trans.	8	1	----	*2405 077	*2405 077
	VA3, VC1, VC2	8	1	----	2200 301	2200 301
6-19-3	BEARING, less Sleeve		1	658 998	658 998	658 998
6-20-0 CLUTCH RELEASE BEARING RETURN SPRING						
8-20-14	SPRING		1	2073 687	2073 687	2073 687
	VA3, VC1, VC2, w/361, 383 cu. in. Eng., 4 Speed Trans.	8	1	----	671 915	671 915
6-22-0 CLUTCH RELEASE FORK						
6-22-1	FORK, includes SPRING		1	2072 902		
	VA3, VC1, VC2, w/361, 383 cu. in. Eng., 4 Speed Trans.	8	1	----	2260 047	
	VV2, VL2, w/273 cu. in. Eng.	8	1	2461 485		1618 848
6-22-4	SEAL, Release Fork		1	2260 021	2260 021	2260 021
	w/4 Speed Trans., VA3	8	1	----	2075 009	2075 009
6-22-15	PIVOT, Release Fork					
	9 1/8" w/170 cu. in. Eng.	6	1	2266 819		
	9 1/4" Clutch, w/225 cu. in. Eng.	6	1	2266 819		
	9 1/4" Clutch, w/225 cu. in. Eng.	6	1	----	2260 719	
	9 1/2" Clutch, w/273 cu. in. Eng.	8	1	2461 484		
	10" Clutch, w/225 cu. in. Eng., Police Cars	6	1	----	2260 719	
	10 1/2" Clutch, w/318, 361, 383 cu. in. Eng., 3 Speed Trans.	8	1	----	*2260 719	
	10 1/2" Clutch, w/426 cu. in. Eng., 4 Speed Trans.	8	1	----	*2260 719	
	10 1/2" Clutch, w/361, 383, 413 cu. in. Eng., 4 Speed Trans., A3, C2, C3	8	1	----	*2409 680	*2409 680
	VP2, VD2, w/426 cu. in. Eng., Hemispherical.	8	1	----	2260 719	
	11" Clutch, w/383, 413 cu. in. Eng.	8	1	----	633 238	633 238
	11" Clutch, w/225 cu. in. Eng., Taxi	6	1	----	2260 719	
6-22-17	PIN, Release Fork		1	1324 090	1324 090	1324 090
6-22-19	SPRING, Release Fork, except VA3		1	2072 901	2072 901	
	VA3	8	1	----	2200 349	2200 349
	RIVET		2	6023 660	6023 660	6023 660
	RIVET, Pivot Spring		2	6023 660	6023 660	6023 660
6-24-0 CLUTCH RELEASE ROD						
6-24-1	END, Front	6	1	2072 849		
	Rear	6	1	1675 246		
	Front, VA3, VC1, All, VC2 w/383 cu. in. Eng.	8	1	----	2200 029	2200 029
	Rear, VA3, VC1 All, VC2 w/383 cu. in. Eng.		1	----	1675 246	1675 246
	ROD, Release Fork, w/225, 318, 361, 383, 426, cu. in. Eng.		1	----	2401 739	2401 739
	VV2, VL2, 9 1/2" Clutch, VV1, VL1 w/Power Brake		1	2461 481		
	ROD, Clutch Release Interlock, Taxi and Police	6	1	----	2405 079	
	CLIP, Interlock Spring	6	1	----	6025 071	
6-24-3	NUT, Rod Adjusting		1	1407 347	1407 347	1407 347

★ Indicates use as required.

Numerals in parentheses () refer to notes.

Printed in U.S.A.

E Indicates parts not listed in any previous parts book.

Prices and specifications subject to change without notice.

* Indicates change or addition.

CODE	PART NAME AND DESCRIPTION	C Y L	PER CAR	VALIANT DART	PLYMOUTH DODGE	CHRYSLER IMPERIAL
6-24-0 CLUTCH RELEASE ROD - Cont'd						
6-24-6	SPRING, Release Fork Rod, Rear		1	1634 508	1634 508	1634 508
6-24-7	WASHER, Release Fork Rod Insulator		1	2461 483	2461 483	2461 483
6-24-8	INSULATOR, Release Rod		1	2461 482	2461 482	2461 482
	SWIVEL, Release Fork Interlock Rod, Police and Taxi	6	1	----	*2404 859	
6-24-14	CLAMP, Release Interlock	6	1	----	2204 274	
6-27-0 CLUTCH RELEASE FORK RETURN SPRING						
6-27-5	SPRING, VV1, VL1	6	1	2072 855		
	VP1, VD1, except 11" Clutch, 3 and 4 Speed Manual Trans.	6	1	----	2260 023	
	VA3, VC1, w/361, 383, 413 cu. in. Eng., 4 Speed Manual Trans.	8	1	----	2260 023	
	VV2, VL2, w/273 cu. in. Eng.	8	1	2461 480		
6-27-10	EXTENSION, Release Fork Return Spring, 11" Clutch	6	1	----	2461 514	
	VA3		1	----	1820 211	1820 211
6-35-0 CLUTCH RELEASE OVER CENTER SPRING						
6-35-1	SPRING	6	1	2266 784	2260 728	
	w/225 cu. in. Eng., Taxi and Police	6	1	----	2260 727	
	w/318, 361, 383, 426 cu. in. Eng., except VA3	8	1	----	2260 727	
	w/225 cu. in. Eng., 11" Clutch	6	1	----	2260 727	
	w/361, 383 cu. in. Eng., VA3	8	1	----	2260 739	2260 739
	w/361, 383 cu. in. Eng., w/4 Speed Trans., VA3 w/273 cu. in. Eng.	8	1	2461 515	2260 739	2260 739
6-35-9	HOOK, Over Center Spring, includes Taxi		1	2266 777		
6-35-16	SPACER, Over Center Spring, except VA3		1	----	2460 344	
	VA3		1	----	2460 345	2460 345
6-35-17	NUT, Spacer, VA3		2	----	2076 232	2076 232
6-38-0 CLUTCH PEDAL						
6-38-1	PEDAL		1	2461 508		
	VP1, VD1, w/225 cu. in. Eng.	6	1	----	2460 047	
	VP1, VD1, w/225 cu. in. Eng., 10" Clutch, Police Cars	6	1	----	*2405 114	
	VP1, VD1, 10" Clutch, Power Brake	6	1	----	2405 114	
	VP1, VD1, w/225 cu. in. Eng., 11" Clutch, Taxi	6	1	----	*2405 114	
	VP2, VD2, w/318 cu. in. Eng.	8	1	----	*2405 114	
	VP2, VD2, w/361, 383, 426 cu. in. Eng., Power Brake	8	1	----	*2405 114	
	VA3, VC1, VC2, All	8	1	----	2405 110	2405 110
6-38-3	BEARING, Clutch Pedal		2	1946 377	1946 377	1946 377
	BUSHING		2	1637 779	1637 779	
6-38-14	RING, Pedal Shaft Lock		1	*2072 831		
6-38-23	STOP, Pedal		1	2266 820	2266 820	2266 820
6-39-0 CLUTCH PEDAL PAD						
6-39-2	PAD, except VA3, Black		1	1731 228	1731 228	
	VA3	8	1	----	2405 089	2405 089

* Indicates use as required.

Numerals in parentheses () refer to notes.

Printed in U.S.A.

E Indicates parts not listed in any previous parts book.

Prices and specifications subject to change without notice.

March 15, 1965 Supersedes March 16, 1964.

* Indicates change or addition.

CODE	PART NAME AND DESCRIPTION	CYL	PER CAR	VALIANT DART	PLYMOUTH DODGE	CHRYSLER IMPERIAL
6-43-0 CLUTCH PEDAL SHAFT						
6-43-1	SHAFT		1	----	2405 113	2405 113
6-43-7	WASHER, Shaft Ring	6	1	2073 632		
6-43-13	SEAL, Pedal Bearing		2	1730 019	1730 019	1730 019
6-43-14	RING, Shaft Lock	6	1	2072 831		
6-50-0 CLUTCH PEDAL ROD						
6-50-1	ROD, w/170, 225 cu. in. Eng.	6	1	2073 642		
	w/225, 318 cu. in. Eng.		1	----	2401 725	
	w/225 cu. in. Eng., 11" Clutch, Police and Taxi	6	1	----	2401 725	
	VP1, VD1 w/225 cu. in. Eng., 10" Clutch	6	1	----	2401 725	
	VV1, VV2, VL1, VL2 w/Power Brake		1	*2461 475		
	w/361, 383, 426, cu. in. Eng.	8	1	----	2401 725	
	VA3, VC1, VC2, w/361, 383, cu. in. Eng.,					
	VC3, w/383, 413, cu. in. Eng.	8	1	----	2260 073	2260 073
6-50-6	WASHER, Pedal Dampner		1	2405 086	2405 086	2405 086
	WASHER, Spring Pin		1	2405 085	2405 085	2405 085
6-50-10	BOOT, Pedal Rod		1	2266 783	2266 818	2266 818
6-52-0 CLUTCH TORQUE SHAFT						
6-52-1	SHAFT, includes PINS	6	1	2265 930		
	VV2, VL2	8	1	2461 491		
	VP2, VD2, w/361, 383, 426 cu.in. Eng.	8	1	----	*2421 399	
	Taxi, w/11" Clutch	6	1	----	2260 678	
	VP1, VD1, w/225 cu. in. Eng., 10" Clutch,	6	1	----	2421 399	
	w/Interlock, Police	6	1	----	2421 399	
	VP1, VD1, w/225 cu.in. Eng., Taxi and Police,					
	Export	6	1	----	*2421 399	
	VA3	8	1	----	2401 747	2401 747
6-52-10	BRACKET, Torque Shaft, Frame End	6	1	2265 944		
	VV1, VL1, VV2, VL2, w/Power Brake	6	1	----	2260 718	
	Except VA3	8	1	2461 476		
	VA3	8	1	----	2260 718	
	BRACKET, Torque Shaft, Eng. End	8	1	----	2265 943	2265 943
	w/225 cu. in. Eng.	6	1	2260 746		
	Heavy Duty, Taxi and Police	6	1	----	2260 744	
	VV1, VV2, VL1, VL2, w/Power Brake		1	2461 478		
	w/318 cu. in. Eng.	8	1	----	2260 746	
	w/361, 383, 426, cu. in. Eng.	8	1	----	2260 746	
	w/225 cu.in. Eng., 11" Clutch	6	1	----	2260 746	
	4 Speed Trans.	8	1	----	1829 383	1829 383
	STUD, Eng. End, VA3	8	1	----	1829 383	1829 383
	SCREW, w/WASHER, Torque Shaft Bracket					
	Eng. End	6	2	6025 084	6025 084	
	SCREW, w/WASHER, Torque Shaft Pivot Eng. End	8	2	----	6023 886	
	SCREW, Torque Shaft Bracket	8	2	----	----	6024 345
6-52-11	BEARING, Torque Shaft Pivot		4	2265 938	2265 938	2265 938
6-52-12	RING, Pivot Snap, 1 1/8" LD.		1	2265 939	2265 939	
	1 1/4" LD.		1	2401 910	2401 910	2401 910
6-52-17	SEAL, Torque Shaft		2	2265 942	2265 942	2265 942

* Indicates use as required.

Numerals in parentheses () refer to notes.

Printed in U.S.A.

⊠ Indicates parts not listed in any previous parts book.

Prices and specifications subject to change without notice.

• Indicates change or addition.

March 15, 1965 Supersedes March 16, 1964.

