

19x9917 A

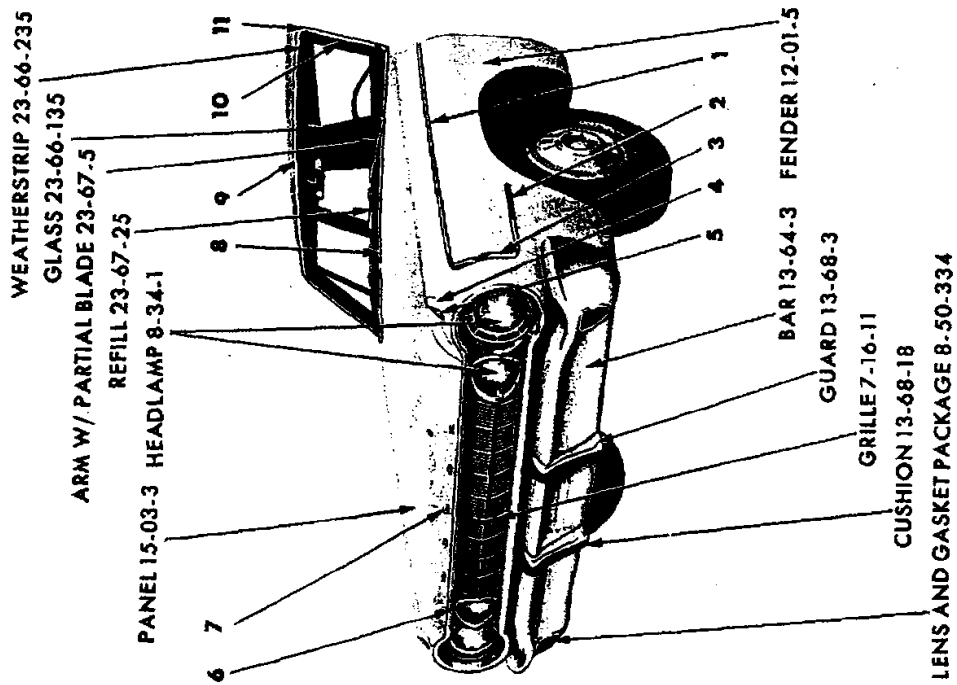

EXTERIOR VIEW - DODGE VDI-2(L) 4 DOOR SEDAN

REF. NO.	QTY	PART NUMBER	DESCRIPTION	REF. NO.	QTY	PART NUMBER	DESCRIPTION
1	1	2495 266-7	MOULDING PACKAGE, Fender Side Upper (12-15-2)	13	1	2480 920-1	MOULDING, Rear Window Outside Lower Corner (23-23-52)
	4	6001 591	Retainer		2	6023 693	Screw
	14	6001 497	Retainer	14	1	2495 269	MOULDING PACKAGE, Rear Window Outside Upper (23-23-52)
	4	6023 685	Nut		6	6001 525	Retainer and Screw
2	1	2525 552-3	MOULDING PACKAGE, Fender Side Lower (12-15-2)	15	1	2480 922	MOULDING, Rear Window Outside Lower (23-23-52)
	4	6001 591	Retainer		6	6023 693	Screw
	4	6023 685	Nut	16	1	2480 918-9	MOULDING, Rear Window Outside Side (23-23-52)
3	1	2495 716-7	CAP PACKAGE, Fender Side Moulding Front (12-15-9)		6	6001 525	Retainer and Screw
	8	6023 685	Nut	17	1	2486 313	ORNAMENT, Deck Lid Lock Cylinder (23-17-19)
4	1	2445 112-3	BASE, Fender Top Medallion (12-15-23)	18	2	2417 825	"D", Deck Lid Letter (23-19-114)
	2	-----	Nut		1	2417 826	"O"
5	2	2449 534	MEDALLION, Fender Top (12-15-21)		1	2417 828	"G"
					1	2417 829	"E"
6	1	2495 253	MOULDING PACKAGE, Hood Front (15-25-2)		10	152 259	Nut
	8	-----	Nut	19	2	2526 914	NAME PLATE, Quarter Outside (23-34-238)
	8	6001 087	Retainer		4	6023 260	Nut
7	1	2417 825	NAME LETTER, Hood Front "D" (15-08-16)	20	1	2495 304-5	MOULDING PACKAGE, Quarter Panel Lower (23-23-39)
	1	2417 826	"O"		16	6001 497	Clip
	1	2417 827	"D"		4	6001 474	Retainer
	1	2417 828	"G"		4	-----	Washer
	1	2417 829	"E"		4	6024 679	Nut
	10	1839 995	Nut	21	1	2448 150-1	MOULDING PACKAGE, Quarter Panel Belt (23-23-39)
8	1	2218 595	MOULDING, Windshield Outside Finish Lower (23-23-65)		6	6001 030	Retainer
	10	6001 537	Retainer and Screw		6	152 259	Nut
9	1	2218 594	MOULDING, Windshield Outside Upper (23-23-65)	22	1	2526 994-5	DEFLECTOR, Quarter Panel Wheel Opening (23-34-240)
	8	6001 537	Retainer and Screw		6	6024 288	Screw
10	1	2218 596-7	MOULDING, Windshield Outside Finish Side (23-23-65)	23	1	2495 322-3	MOULDING PACKAGE, Rear Door (23-23-33)
	6	6023 247	Screw		10	6001 497	Clip
11	1	2491 014-5	MOULDING, Windshield Outside Side Upper Extension (23-23-65)		2	6001 108	Retainer
	6	6024 271	Screw		2	9418 877	Nut
12	1	2483 436	MOULDING, Roof Drain Trough Side (23-59-61)	24	1	2495 326-7	MOULDING PACKAGE, Front Door (23-23-32)
					10	6001 497	Clip
					2	6001 108	Retainer
					2	9418 877	Nut

All Packages Include Attaching Parts

Part Type Code is Indicated in Parentheses

EXTERIOR VIEW - DODGE VD1-2(L) 4 DOOR SEDAN

19x9903A

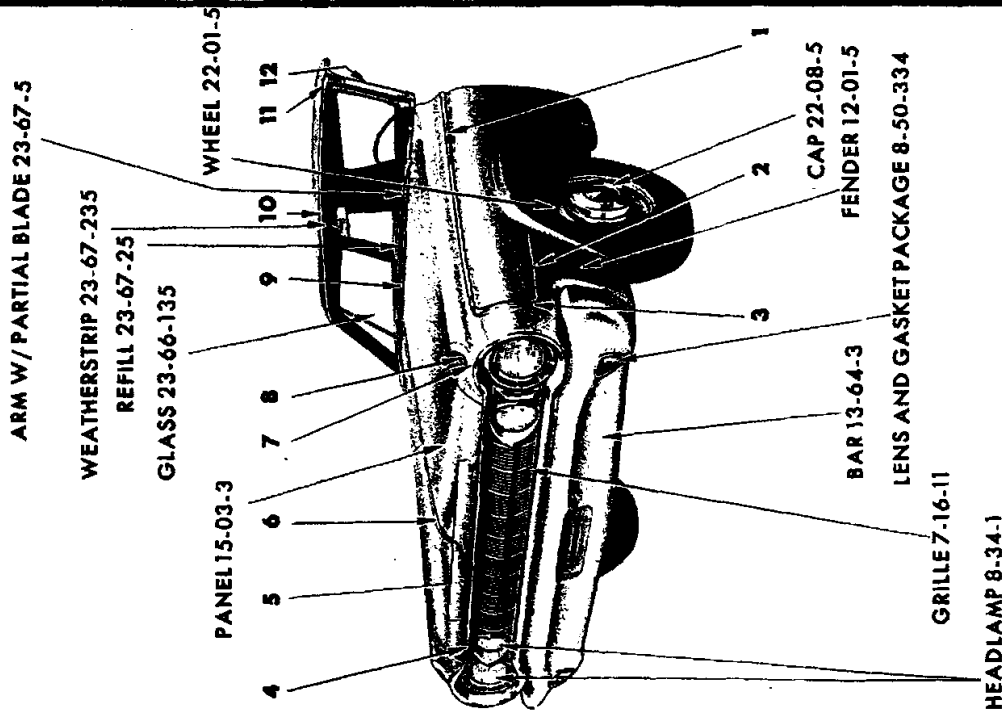
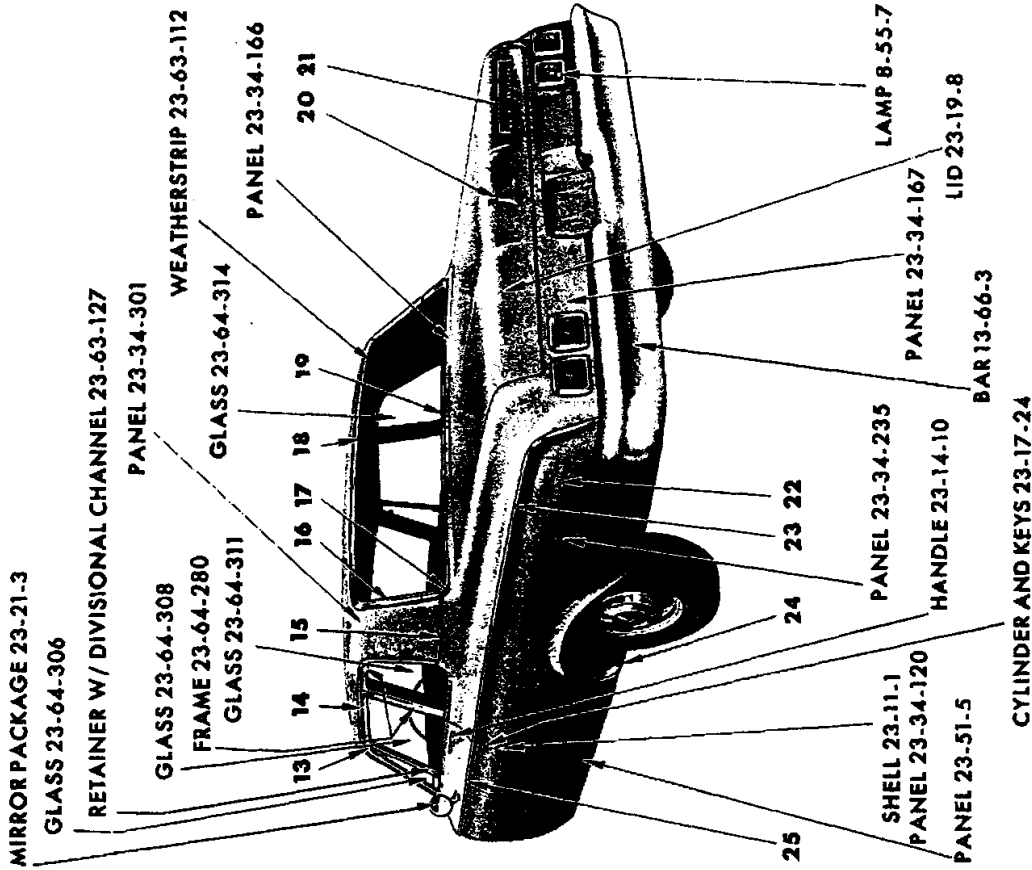

EXTERIOR VIEW - DODGE VD1-2(L) 2 DOOR SEDAN

REF. NO.	QTY	PART NUMBER	DESCRIPTION	REF. NO.	QTY	PART NUMBER	DESCRIPTION
1	1	2495 266-7	MOULDING PACKAGE, Fender Side Upper (12-15-2)	13	2	2422 976	CAP, Roof Drain Trough Moulding Front End (23-59-57)
	4	6001 591	Retainer	14	1	2483 436-7	MOULDING, Roof Drain Trough Side (23-59-61)
14		8001 497	Retainer	15	1	2448 150-1	MOULDING PACKAGE, Quarter Panel Belt (23-23-39)
	4	6023 685	Nut		6	6001 030	Retainer
2	1	2525 552-3	MOULDING PACKAGE, Fender Side Lower (12-15-2)		6	152 259	Nut
	4	6001 591	Retainer	16	1	2480 918-9	MOULDING, Rear Window Outside Side (23-23-52)
	4	6023 685	Nut		6	6001 525	Retainer and Screw
3	1	2495 716-7	CAP PACKAGE, Fender Side Moulding Front (12-15-2)	17	1	2480 920-1	MOULDING, Rear Window Outside Lower Corner (23-23-52)
	8	6023 685	Nut		2	6023 693	Screw
4	1	2495 253	MOULDING PACKAGE, Hood Front (15-25-2)	18	1	2495 269	MOULDING PACKAGE, Rear Window Outside Upper (23-23-52)
	8	-----	Nut		6	6001 525	Retainer and Screw
	8	8001 087	Retainer	19	1	2480 922	MOULDING, Rear Window Outside Lower (23-23-52)
5	1	2417 825	LETTER, Hood Front Name, "D", Front (15-06-16)		6	6023 693	Screw
	1	2417 826	"O"	20	1	2486 313	ORNAMENT, Deck Lid Lock Cylinder (23-17-19)
	1	2417 827	"D", Center	21	2	2417 825	"D", Deck Lid Letter (23-19-114)
	1	2417 828	"G"		1	2417 826	"O"
	1	2417 829	"E"		1	2417 828	"G"
	10	1839 995	Nut		1	2417 829	"E"
6	1	2495 252	MOULDING PACKAGE, Hood Top (15-25-2)		10	152 259	Nut
	5	9414 977	Nut	22	2	2526 914	NAME PLATE, Quarter Outside (23-34-238)
	4	2445 120	Spacer		4	6023 260	Nut
7	2	2445 112-3	BASE, Fender Top Medallion (12-15-23)	23	1	2495 302-3	MOULDING PACKAGE, Quarter Panel Lower (23-23-39)
	2	-----	Nut		24	6001 497	Clip
8	2	2449 534	MEDALLION, Fender Top (12-15-21)	24	1	2526 994-5	DEFLECTOR, Quarter Panel Wheel Opening Stone (23-34-240)
9	1	2218 595	MOULDING, Windshield Outside Finish Lower (23-23-65)		6	6024 288	Screw
	10	6001 537	Retainer and Screw	25	1	2495 324-5	MOULDING PACKAGE, Door (23-23-32)
10	1	2218 594	MOULDING, Windshield Outside Upper (23-23-65)		12	6001 497	Clip
	8	6001 537	Retainer and Screw		2	6001 108	Retainer
11	1	2491 014-5	MOULDING, Windshield Outside Side Upper Extension (23-23-65)		2	9418 877	Nut
	6	6024 271	Screw				
12	1	2218 596-7	MOULDING, Windshield Outside Finish Side (23-23-65)				
	6	6023 247	Screw				

All Packages include Attaching Parts

Part Type Code is indicated in Parentheses

EXTERIOR VIEW - DODGE VD1-2(L) 2 DOOR SEDAN

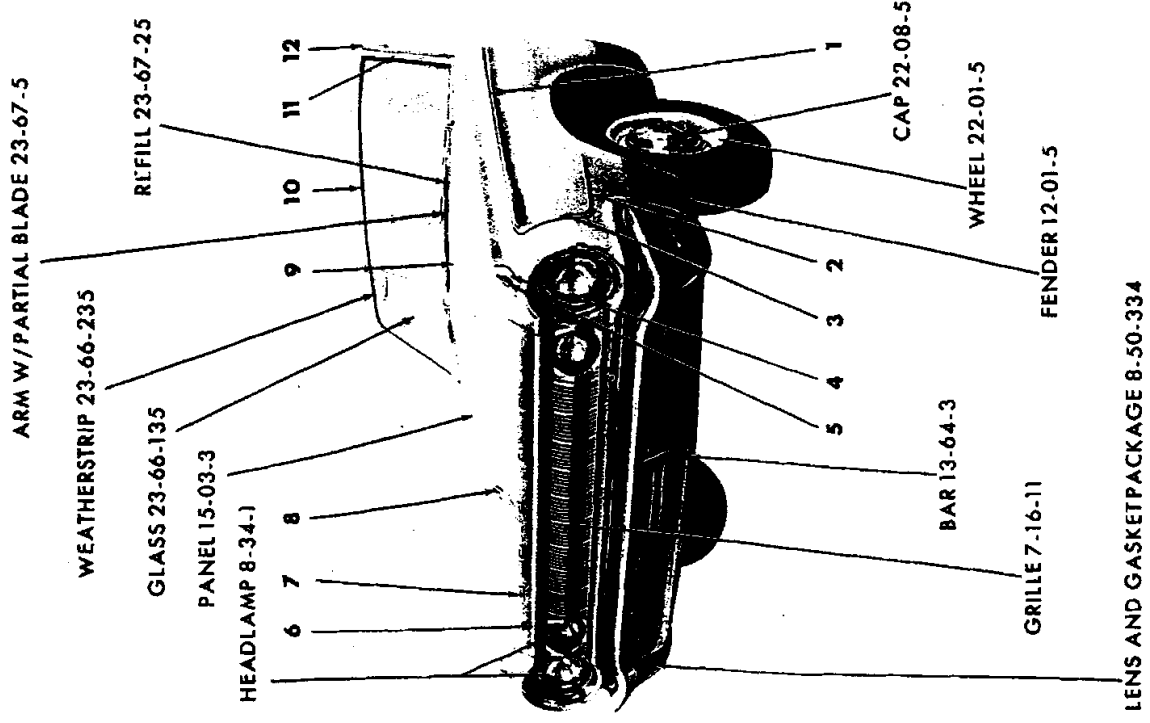
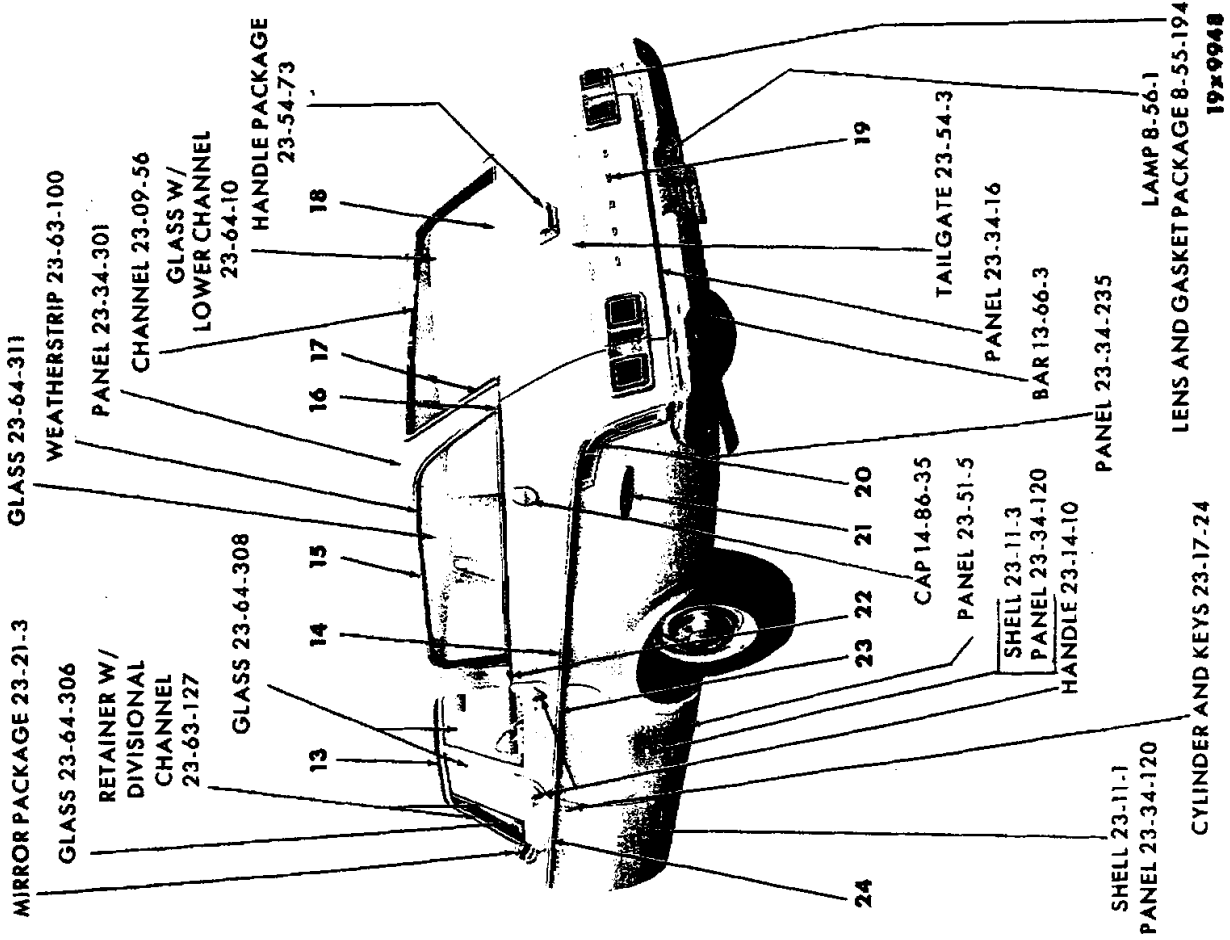

EXTERIOR VIEW - DODGE VDI-2(L) 4 DOOR STATION WAGON

REF. NO.	QTY	PART NUMBER	DESCRIPTION
1	1	2495 266-7	MOULDING PACKAGE, Fender Side Upper (12-15-2)
	4	6001 591	Retainer
	14	6001 497	Retainer
	4	6023 685	Nut
2	1	2525 552-3	MOULDING PACKAGE, Fender Side Lower (12-15-2)
	4	6001 591	Retainer
	4	6023 685	Nut
3	1	2495 716-7	CAP PACKAGE, Fender Side Moulding Front (12-15-9)
	8	6023 685	Nut
4	1	2445 112-3	BASE, Fender Top Medallion (12-15-23)
	2	-----	Nut
5	2	2449 534	MEDALLION, Fender Top (12-15-21)
6	1	2495 253	MOULDING PACKAGE, Hood Front (15-25-2)
	8	-----	Nut
	8	6001 087	Retainer
7	1	2417 825	LETTER, Hood Front Name, "D" Front (15-06-16)
	1	2417 826	"O"
	1	2417 827	"D", Center
	1	2417 828	"G"
	1	2417 829	"E"
	10	1839 995	Nut
8	1	2495 252	MOULDING PACKAGE, Hood Top (15-25-2)
	5	9414 977	Nut
	4	2445 120	Spacer
9	1	2218 595	MOULDING, Windshield Outside Finish Lower (23-23-65)
	10	6001 537	Retainer and Screw
10	1	2218 594	MOULDING, Windshield Outside Upper (23-23-65)
	8	6001 537	Retainer and Screw
11	1	2218 596-7	MOULDING, Windshield Outside Finish Side (23-23-65)
	6	6023 247	Screw
12	1	2491 014-5	MOULDING, Windshield Outside Side Upper Extension (23-23-65)
	6	6024 271	Screw
13	1	2483 436-7	MOULDING, Roof Drain Trough Side (23-59-61)

REF. NO.	QTY	PART NUMBER	DESCRIPTION
14	1	2495 442-3	MOULDING PACKAGE, Quarter Panel Front (23-23-39)
	10	6001 497	Clip
	4	6024 679	Nut
	4	-----	Washer
	4	6001 474	Retainer
15	2	2422 471	LOCKINGSTRIP, Quarter Window Glass Weatherstrip (23-63-110)
16	2	2424 626	CAP, Quarter Window Locking-strip (23-63-117)
17	1	2480 976-7	MOULDING, Rear Upper Pillar Outside (23-23-60)
	8	9417 732	Screw
18	1	2448 488	MOULDING PACKAGE, Tailgate Outside Panel Belt (23-23-61)
	6	6001 436	Clip
	6	-----	Screw
19	2	2417 825	LETTER "D", Tailgate Outside Panel (23-54-11)
	1	2417 826	"O"
	1	2417 828	"G"
	1	2417 829	"E"
	10	6000 050	Speed Clip
20	1	2495 480-1	MOULDING PACKAGE, Quarter Panel Rear (23-23-39)
	4	6023 898	Screw
	4	6000 960	Clip
	2	6024 651	Screw
21	2	2526 914	NAME PLATE, Quarter Outside (23-34-238)
	4	6023 260	Nut
22	1	2299 374	MOULDING PACKAGE, Quarter Panel Belt, Right (23-23-39)
	1	2299 399	MOULDING PACKAGE, Quarter Panel Belt, Left (23-23-39)
	4	6001 071	Clip
23	1	2495 322-3	MOULDING PACKAGE, Rear Door (23-23-32)
	10	6001 497	Clip
	2	6001 108	Retainer
	2	9148 877	Nut
24	1	2495 326-7	MOULDING PACKAGE, Front Door (23-23-32)
	10	6001 497	Clip
	2	6001 108	Retainer
	2	9418 877	Nut

All Packages Include Attaching Parts

Part Type Code is Indicated in Parentheses

EXTERIOR VIEW - DODGE VD1-2(L) 4 DOOR STATION WAGON

WEATHERSTRIP 23-66-235

ARM W/ PARTIAL BLADE 23-67-5

REFILL 23-67-25

GLASS 23-66-135

PANEL 15-03-3

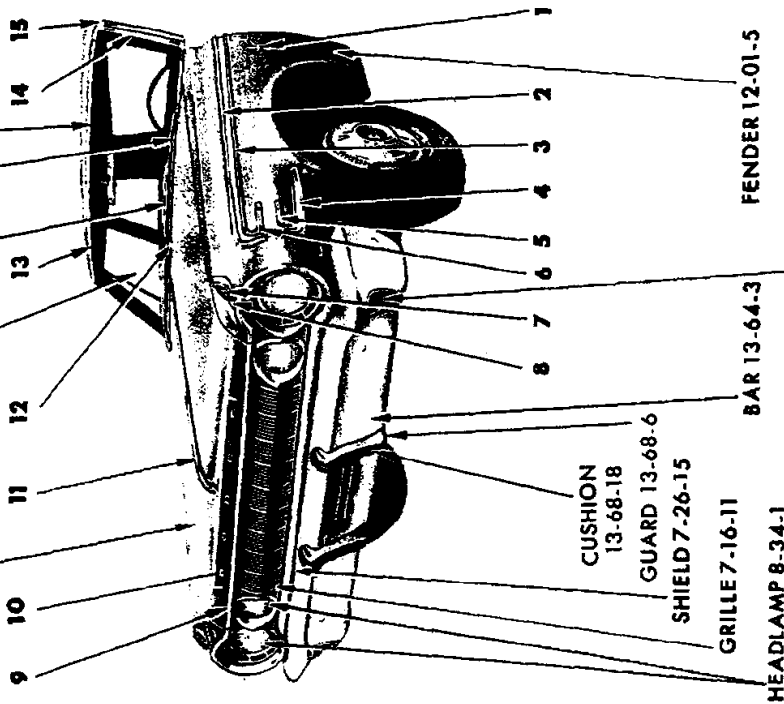

CUSHION 13-68-18

GUARD 13-68-6

SHIELD 7-26-15

GRILLE 7-16-11

HEADLAMP 8-34-1

BAR 13-64-3

FENDER 12-01-5

LENS AND GASKET PACKAGE 8-50-334

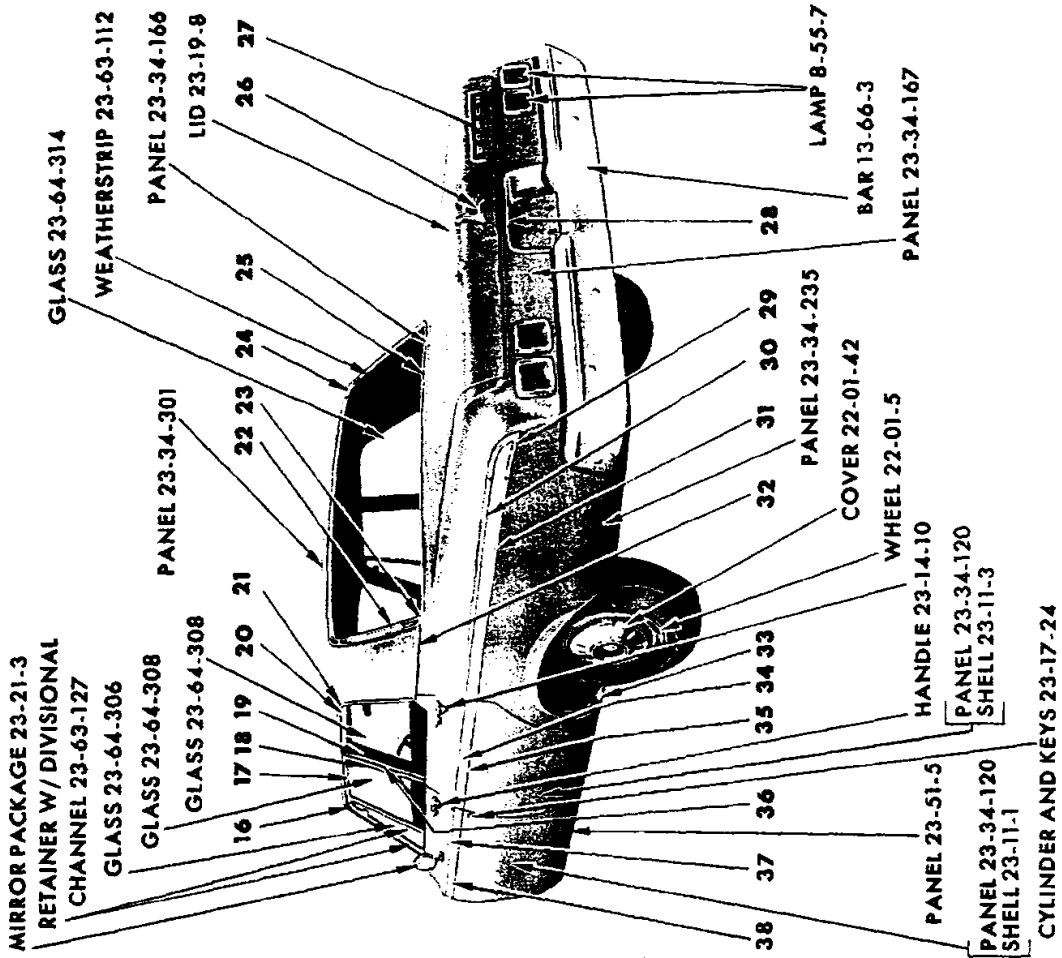

MIRROR PACKAGE 23-21-3  
RETAINER W/ DIVISIONAL CHANNEL 23-63-127  
GLASS 23-64-306

GLASS 23-64-308  
GLASS 23-64-308

PANEL 23-34-301

GLASS 23-64-314

WEATHERSTRIP 23-63-112

PANEL 23-34-166

LID 23-19-8

LAMP 8-55-7

BAR 13-66-3

PANEL 23-34-167

PANEL 23-34-235

COVER 22-01-42

WHEEL 22-01-5

HANDLE 23-14-10

PANEL 23-34-120

SHELL 23-11-3

PANEL 23-51-5

PANEL 23-34-120

SHELL 23-11-1

CYLINDER AND KEYS 23-17-24

19x9905A

EXTERIOR VIEW - DODGE VDI-2(M) 4 DOOR SEDAN

REF. NO.	QTY	PART NUMBER	DESCRIPTION
1	2	2445 097	NAME PLATE, Fender Side (12-15-21)
	8	6001 254	Clip
2	1	2495 266-7	MOULDING PACKAGE, Fender Side Upper (12-15-2)
	4	6001 591	Retainer
	14	6001 497	Retainer 4 6023 685 Nut
3	1	2495 720-1	MOULDING PACKAGE, Fender Side Lower (12-15-2)
	4	6001 591	Retainer
	14	6001 497	Retainer 4 6023 685 Nut
4	1	2495 722-3	CAP PACKAGE, Fender Side Moulding Rear (12-15-9)
	8	6023 685	Nut
5	1	2495 724-5	ORNAMENT PACKAGE, Fender Side (12-15-21)
	10	6023 685	Nut
6	1	2495 716-7	CAP PACKAGE, Fender Side Moulding Front (12-15-9)
	8	6023 685	Nut
7	2	2449 534	MEDALLION, Fender Top (12-15-21)
8	1	2445 112-3	BASE, Fender Top Medallion (12-15-23)
	2	----	Nut
9	1	2495 253	MOULDING PACKAGE, Hood Front (15-25-2)
	8	----	Nut
	8	6001 087	Retainer, w/Stud
10	1	2417 825	LETTER, Hood Front Name, "D", Front (15-06-16)
	1	2417 826	"O"
	1	2417 827	"D", Center
	1	2417 828	"G"
	1	2417 829	"E"
	10	1839 995	Nut
11	1	2495 252	MOULDING PACKAGE, Hood Top (15-25-2)
	5	9414 977	Nut
	4	2445 120	Spacer
12	1	2218 595	MOULDING, Windshield Outside Finish Lower (23-23-65)
	10	6001 537	Retainer and Screw
13	1	2218 594	MOULDING, Windshield Outside Upper (23-23-65)
	8	6001 537	Retainer and Screw
14	1	2218 596-7	MOULDING, Windshield Outside Finish Side (23-23-65)
	6	6023 247	Screw
15	1	2491 014-5	MOULDING, Windshield Outside Upper Extension (23-23-65)
	6	6024 271	Screw
16	2	2422 976	CAP, Roof Drain Trough Moulding Front End (23-59-57)
17	1	2218 444-5	MOULDING, Front Door Frame Upper and Front (23-23-32)
18	1	2167 998-9	MOULDING, Front Door Window Frame Rear (23-23-32)
19	1	2167 998-9	MOULDING, Rear Door Window Frame Front (23-23-33)
20	1	2216 036-7	MOULDING, Rear Door Window Frame Upper (23-23-33)
21	1	2483 436-7	MOULDING, Roof Drain Trough Side Front (23-59-61)

All Packages include Attaching Parts

REF. NO.	QTY	PART NUMBER	DESCRIPTION
22	1	2480 918-9	MOULDING, Rear Window Outside Side (23-23-52)
	6	6001 525	Retainer and Screw
23	1	2480 920-1	MOULDING, Rear Window Outside Lower Corner (23-23-52)
	2	6023 693	Screw
24	1	2495 269	MOULDING PACKAGE, Rear Window Outside Upper (23-23-52)
	6	6001 525	Retainer and Screw
25	1	2480 922	MOULDING, Rear Window Outside Lower (23-23-52)
	6	6023 693	Screw
26	1	2486 313	ORNAMENT, Deck Lid Lock Cylinder (23-17-19)
27	2	2417 825	"D", Deck Lid Letter (23-19-114)
	1	2417 826	"O"
	1	2417 828	"G"
	1	2417 829	"E"
	10	152 259	Nut
28	1	2484 994-5	MOULDING, Deck Lower Panel License Depression, use w/Back-Up Lamp (23-23-23)
	1	2495 946-7	MOULDING PACKAGE, Deck Lower Panel License Depression, use w/o Back-Up Lamp (23-23-23)
	*	6024 245	Nut * 6024 271 Screw
29	1	2495 478-9	MOULDING PACKAGE, Quarter Panel End (23-23-39)
	6	6023 260	Nut
30	1	2495 440-1	MOULDING PACKAGE, Quarter Panel Upper (23-23-39)
	12	6001 497	Clip 4 ---- --- Washer
	4	6001 474	Retainer 4 6023 678 Nut
31	1	2495 474-5	MOULDING PACKAGE, Quarter Panel Lower (23-23-39)
	4	6001 467	Retainer 14 6001 497 Clip
32	1	2448 150-1	MOULDING PACKAGE, Quarter Panel Belt (23-23-39)
	6	6001 030	Retainer 6 152 259 Nut
33	1	2526 994-5	DEFLECTOR, Quarter Panel Wheel Opening Stone (23-34-240)
	6	6024 288	Screw
34	1	2495 322-3	MOULDING PACKAGE, Rear Door Upper (23-23-33)
	2	6001 108	Retainer
	10	6001 497	Clip 2 9417 383 Nut
35	1	2495 470-1	MOULDING PACKAGE, Rear Door Lower (23-23-33)
	10	6001 497	Clip
	2	6001 056	Retainer 2 9417 383 Nut
36	1	2216 356-7	PANEL, Center Upper Pillar Finish (23-23-16)
	4	6022 890	Screw
37	1	2495 326-7	MOULDING PACKAGE, Front Door Upper (23-23-32)
	10	6001 497	Clip
	2	6001 108	Retainer 2 9417 383 Nut
38	1	2495 468-9	MOULDING PACKAGE, Front Door Lower (23-23-32)
	12	6001 497	Clip
	2	6001 056	Retainer 2 9417 383 Nut

Part Type Code is Indicated in Parentheses

EXTERIOR VIEW - DODGE VD1-2(M) 4 DOOR SEDAN



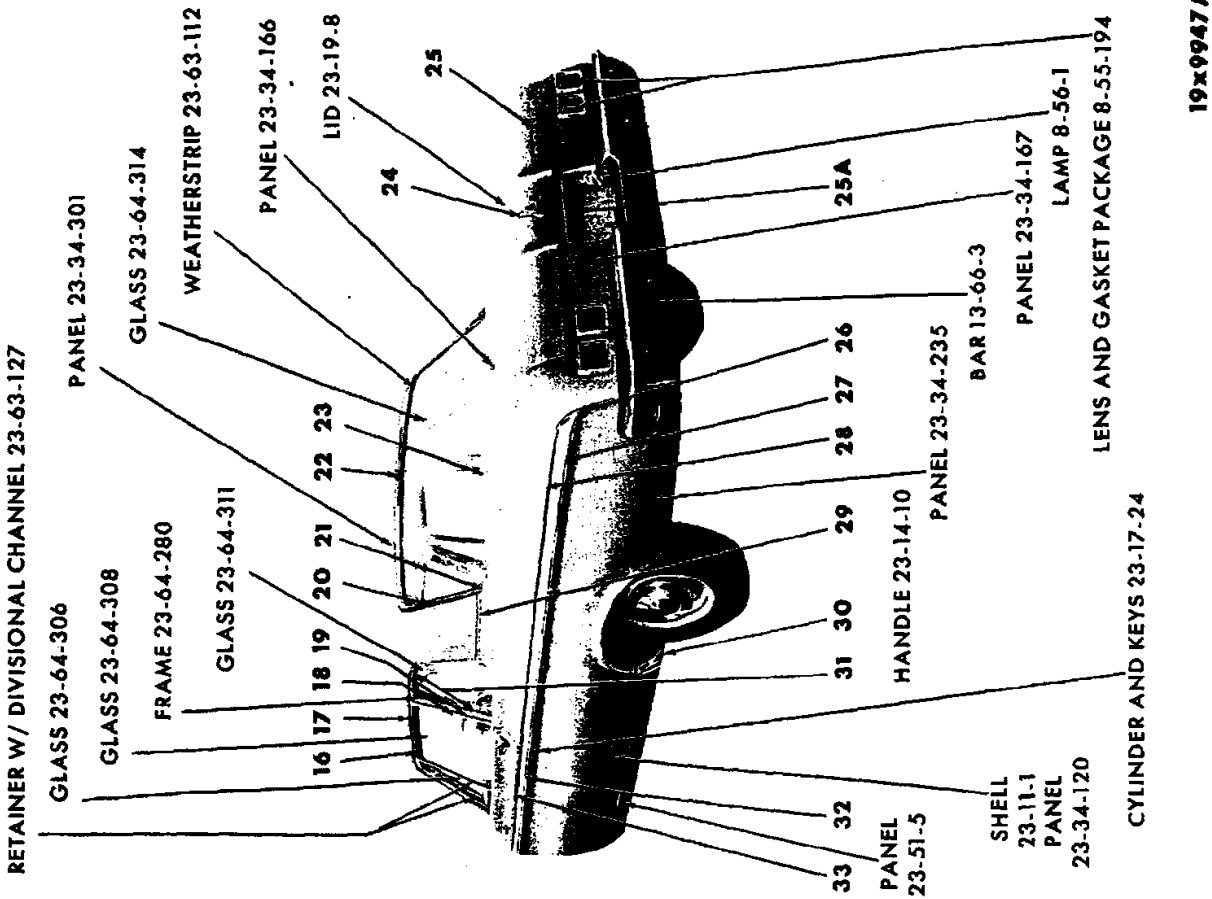

19x9947A

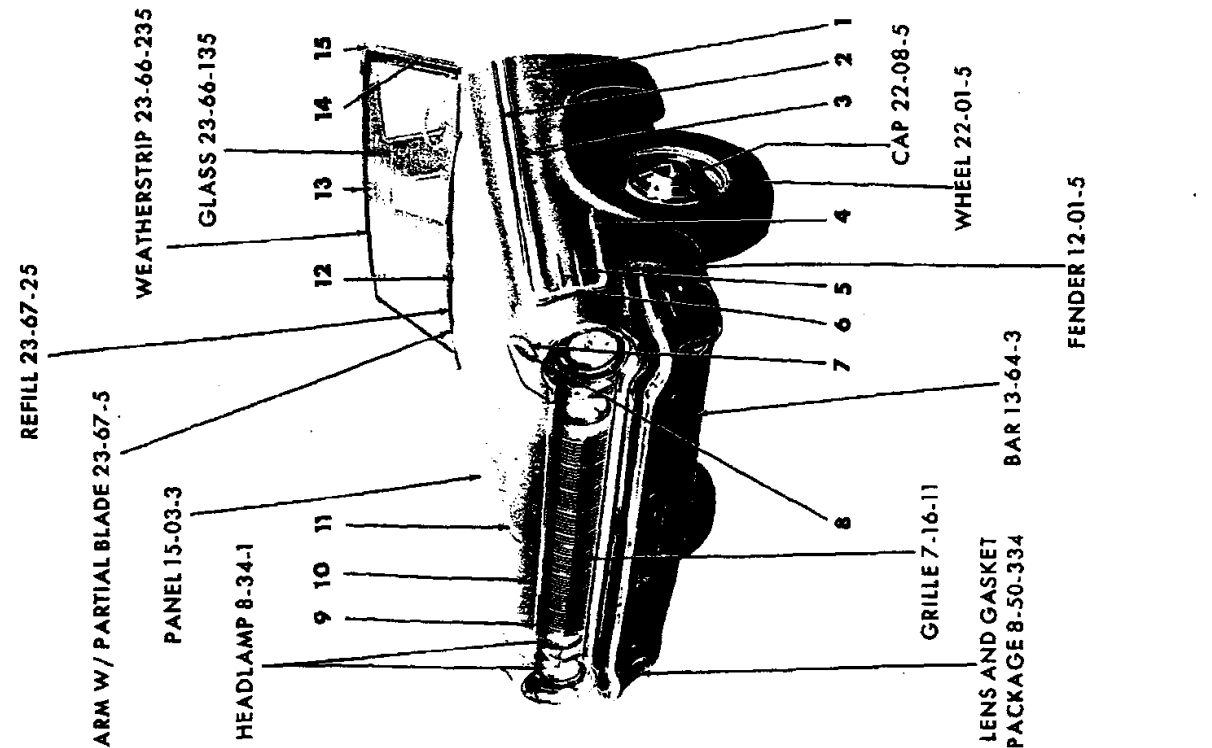

EXTERIOR VIEW - DODGE VDI-2(M) 2 DOOR SEDAN

REF. NO.	QTY	PART NUMBER	DESCRIPTION	REF. NO.	QTY	PART NUMBER	DESCRIPTION
1	2	2445 097	NAME PLATE, Fender Side (12-15-21)	22	1	2495 269	MOULDING PACKAGE, Rear Window Outside Upper (23-23-52)
	8	6001 254	Clip		6	6001 525	Retainer and Screw
2	1	2495 266-7	MOULDING PACKAGE, Fender Side Upper (12-15-2)	23	1	2480 922	MOULDING, Rear Window Outside Lower (23-23-52)
	4	6001 591	Retainer		6	6023 693	Screw
	14	6001 497	Retainer	24	1	2486 313	ORNAMENT, Deck Lid Lock Cylinder (23-17-19)
	4	6023 685	Nut	25	2	2417 825	"D", Deck Lid Letter (23-19-114)
3	1	2495 720-1	MOULDING PACKAGE, Fender Side Lower (12-15-2)		1	2417 826	"O"
	4	6001 591	Retainer		1	2417 828	"G"
	14	6001 497	Retainer		1	2417 829	"E"
	4	6023 685	Nut		10	152 259	Nut
4	1	2495 722-3	CAP PACKAGE, Fender Side Moulding Rear (12-15-9)	25A	1	2484 994-5	MOULDING, Deck Lower Panel License Depression, use w/Back-Up Lamp (23-23-23)
	8	6023 685	Nut		1	2495 946-7	MOULDING PACKAGE, Deck Lower Panel License Depression, use w/o Back-Up Lamp (23-23-23)
5	1	2495 724-5	ORNAMENT PACKAGE, Fender Side (12-15-21)		★	6024 245	Nut
	10	6023 685	Nut		★	6024 271	Screw
6	1	2495 716-7	CAP PACKAGE, Fender Side Moulding Front (12-15-2)	26	1	2495 478-9	MOULDING PACKAGE, Quarter Panel End (23-23-39)
	8	6023 685	Nut		6	6023 260	Nut
7	1	2445 112-3	BASE, Fender Top Medallion (12-15-23)	27	1	2495 472-3	MOULDING PACKAGE, Quarter Panel Lower (23-23-39)
	2	----	Nut		4	----	Retainer
8	2	2449 534	MEDALLION, Fender Top (12-15-21)		2	6001 595	Retainer
9	1	2495 253	MOULDING PACKAGE, Hood Front (15-25-2)		2	6024 679	Nut
	8	----	Nut	28	1	2495 438-9	MOULDING PACKAGE, Quarter Panel Upper (23-23-39)
10	1	2417 825	LETTER, Hood Front Name, "D", Front (15-06-16)		4	6001 474	Retainer
	1	2417 826	"O"		4	----	Washer
	1	2417 827	"D", Center		20	6001 497	Clip
	1	2417 828	"G"		4	6024 679	Nut
	1	2417 829	"E"	29	1	2448 150-1	MOULDING PACKAGE, Quarter Panel Belt (23-23-39)
	10	1839 995	Nut		6	6001 030	Retainer
11	1	2495 252	MOULDING PACKAGE, Hood Top (15-25-2)		6	152 259	Nut
	4	2445 120	Spacer	30	1	2526 994-5	DEFLECTOR, Quarter Panel Wheel Opening Stone (23-34-240)
	5	9414 977	Nut		6	6024 288	Screw
12	1	2218 595	MOULDING, Windshield Outside Finish Lower (23-23-65)	31	1	2422 438-9	MOULDING, Quarter Window Opening Frame Outside Upper (23-23-73)
	10	6001 537	Retainer and Screw		2	2422 534	Retainer
13	1	2218 594	MOULDING, Windshield Outside Upper (23-23-65)		1	2422 440-1	MOULDING, Quarter Window Opening Frame Outside Front (23-23-73)
	8	6001 537	Retainer and Screw	32	1	2495 466-7	MOULDING PACKAGE, Door Lower (23-23-32)
14	1	2218 596-7	MOULDING, Windshield Outside Finish Side (23-23-65)		2	6001 576	Retainer
	6	6023 247	Screw		2	6024 676	Washer
15	1	2491 014-5	MOULDING, Windshield Outside Side Upper Extension (23-23-65)		14	6001 497	Clip
	6	6024 271	Screw		2	9419 629	Screw
16	1	2491 716-7	MOULDING, Door Window Frame Upper and Front (23-23-32)	33	1	2495 324-5	MOULDING, Door Upper (23-23-32)
17	1	2493 436-7	MOULDING, Roof Drain Trough Side (23-59-61)		2	6001 108	Retainer
18	1	2218 724-5	MOULDING, Door Window Frame Rear (23-23-32)		2	6001 576	Retainer
19	1	2480 222-3	PANEL, Lock Pillar Upper Finish (23-23-16)		2	6024 676	Washer
20	1	2480 918-9	MOULDING, Rear Window Outside Side (23-23-52)		2	9418 877	Nut
	6	6001 525	Retainer and Screw		14	6001 497	Clip
21	1	2480 920-1	MOULDING, Rear Window Outside Lower Corner (23-23-52)		2	9419 629	Screw
	2	6023 693	Screw				

All Packages Include Attaching Parts

Part Type Code is Indicated in Parentheses

EXTERIOR VIEW - DODGE VD1-2(M) 2 DOOR SEDAN

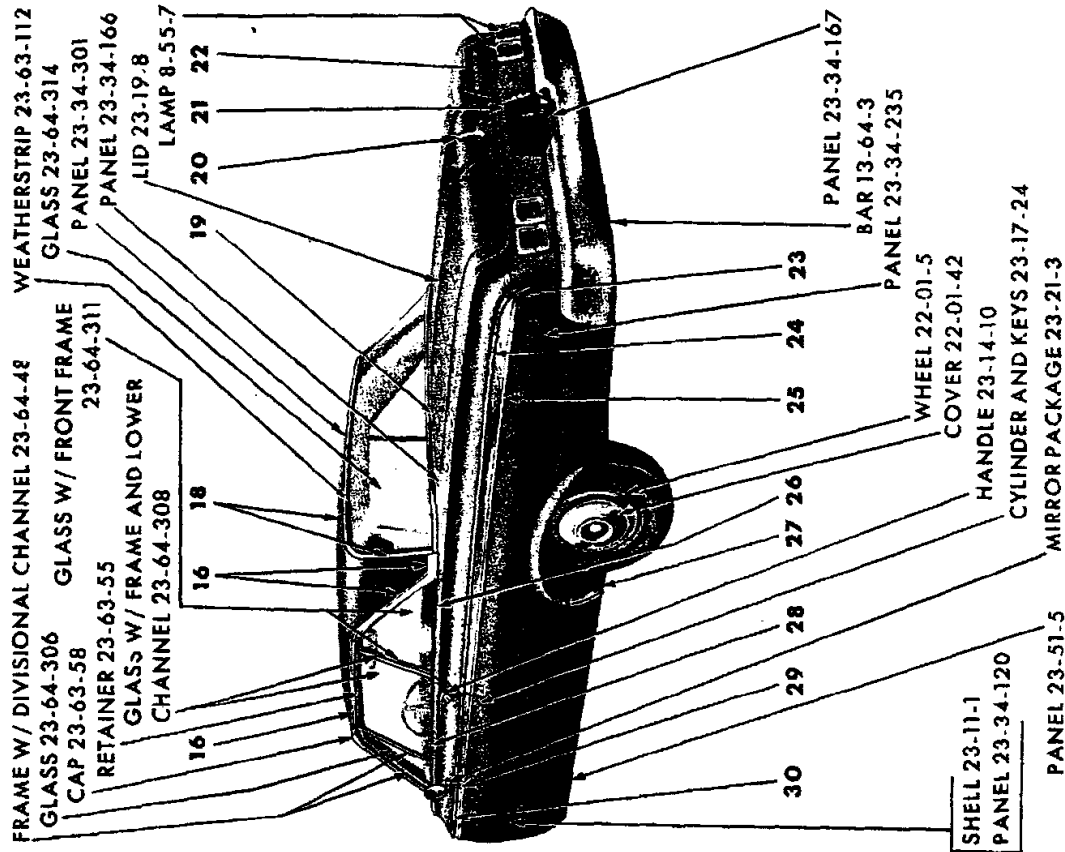

19x9851B

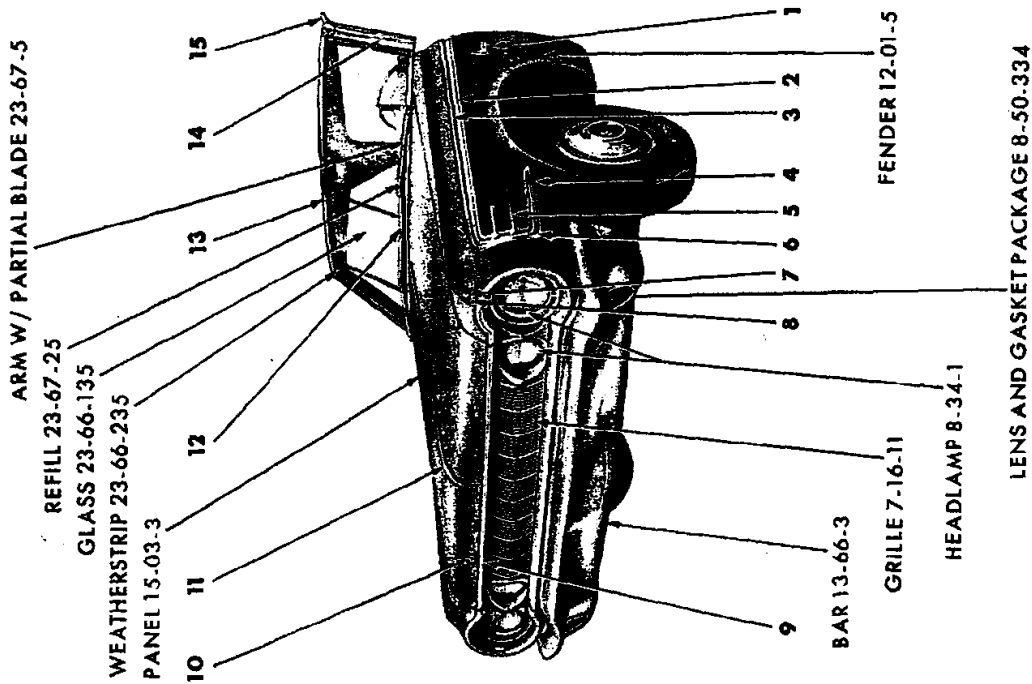

EXTERIOR VIEW - DODGE VDI-2(M) 2 DOOR HARDTOP

REF. NO.	QTY	PART NUMBER	DESCRIPTION	REF. NO.	QTY	PART NUMBER	DESCRIPTION
1	2	2446 097	NAME PLATE, Fender Side (12-15-21)	18	1	2495 276-1	MOULDING PACKAGE, Rear Window Outside Upper and Side (23-23-52)
	8	6001 254	Clip		14	6001 084	Retainer and Screw
2	1	2495 720-1	MOULDING PACKAGE, Fender Side Lower (12-15-2)	19	1	2495 274-1	MOULDING PACKAGE, Rear Window Outside Lower (23-23-52)
	4	6001 591	Retainer		10	6001 084	Retainer and Screw
	14	6001 497	Retainer	20	1	2486 313	ORNAMENT, Deck Lid Lock Cylinder (23-17-19)
	4	6023 685	Nut	21	1	2495 945-7	MOULDING PACKAGE, Deck Lower Panel License Depression (23-23-23)
3	1	2495 266-7	MOULDING PACKAGE, Fender Side Upper (12-15-2)		1	2484 994-5	MOULDING, Deck Lower Panel License Depression, w/Back-Up Lamp Hole (23-23-23)
	4	6001 591	Retainer		★	6024 245	Nut
	14	6001 497	Retainer		★	6024 271	Screw
	4	6023 685	Nut	22	2	2417 825	"D" LETTER, Deck Lid Name (23-19-114)
4	1	2495 722-3	CAP PACKAGE, Fender Side Moulding Rear (12-15-9)		1	2417 826	"O"
	8	6023 685	Nut		1	2417 828	"G"
5	1	2495 724-5	ORNAMENT PACKAGE, Fender Side (12-15-21)		1	2417 829	"E"
	10	6023 685	Nut		10	152 259	Nut
6	1	2495 716-7	CAP PACKAGE, Fender Side Moulding Front (12-15-9)	23	1	2495 478-9	MOULDING PACKAGE, Quarter Panel End (23-23-39)
	8	6023 685	Nut		6	6023 280	Nut
7	2	2449 534	MEDALLION, Fender Top (12-15-21)	24	1	2495 434-9	MOULDING PACKAGE, Quarter Panel Upper (23-23-39)
	2	-----	Nut		20	6001 497	Clip
8	1	2445 112-3	BASE, Fender Top Medallion (12-15-23)		4	6001 474	Retainer
9	1	2495 253	MOULDING PACKAGE, Hood Front (15-25-2)		4	-----	Washer
	8	-----	Nut		4	6024 679	Nut
	8	6001 087	Retainer, w/Stud	25	1	2495 471-3	MOULDING PACKAGE, Quarter Panel Lower (23-23-39)
10	1	2417 825	LETTER, Hood Front Name, "D" (15-06-16)		22	6001 497	Clip
	1	2417 826	"O"		4	6001 487	Retainer
	1	2417 827	"D" Center		2	6001 595	Retainer
	1	2417 828	"G"		2	6024 579	Nut
	1	2417 829	"E"	26	1	2495 320-1	MOULDING PACKAGE, Quarter Panel Belt (23-23-39)
	10	1839 995	Nut		10	6001 500	Clip
11	1	2495 252	MOULDING PACKAGE, Hood Top (15-25-2)		2	6001 438	Clip
	5	9414 977	Nut	27	1	2526 994-5	DEFLECTOR, Quarter Panel Wheel Opening Stone (23-34-240)
	4	2445 120	Spacer		6	6024 282	Screw
12	1	2218 595	MOULDING, Windshield Outside Finish Lower (23-23-65)	28	1	2495 318-9	MOULDING PACKAGE, Door Belt (23-23-32)
	10	6001 537	Retainer and Screw		14	6001 500	Clip
13	1	2218 594	MOULDING, Windshield Outside Upper (23-23-65)	29	1	2495 465-7	MOULDING PACKAGE, Door Lower (23-23-32)
	8	6001 537	Retainer and Screw		12	6001 497	Clip
14	1	2218 596-7	MOULDING, Windshield Outside Finish Side (23-23-65)		4	6001 056	Retainer
	6	6023 247	Screw		4	9418 877	Nut
15	1	2492 712-3	MOULDING, Windshield Outside Side Upper Extension (Narrow Type) (23-23-65)	30	1	2495 324-5	MOULDING PACKAGE, Door Upper (23-23-32)
	1	2491 012-3	MOULDING, Windshield Outside Side Extension (Wide Type) (23-23-65)		16	6001 497	Clip
16	1	2525 556-7	MOULDING, Roof Side Drain Trough Front and Rear (23-59-61)		2	6001 108	Retainer
	6	2483 716	Clip (w/Vinyl Roof)		2	9418 877	Nut
	6	2573 062	Clip (w/o Vinyl Roof)				
	6	6024 271	Screw				
	2	-----	Nut				

All Packages Include Attaching Parts

Part Type Code is Indicated in Parentheses

EXTERIOR VIEW - DODGE VD1-2(M) 2 DOOR HARDTOP

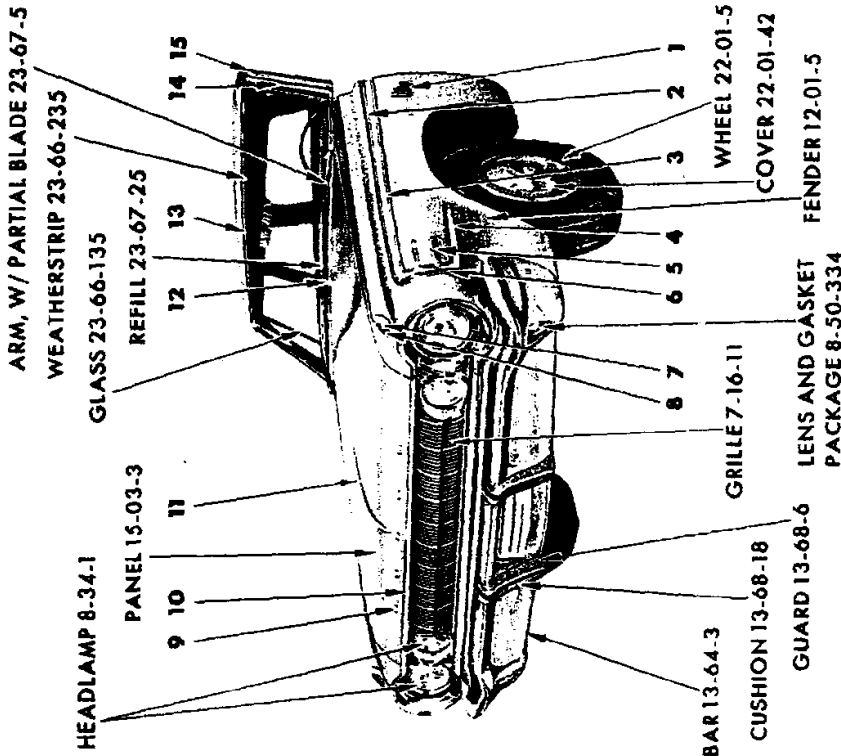
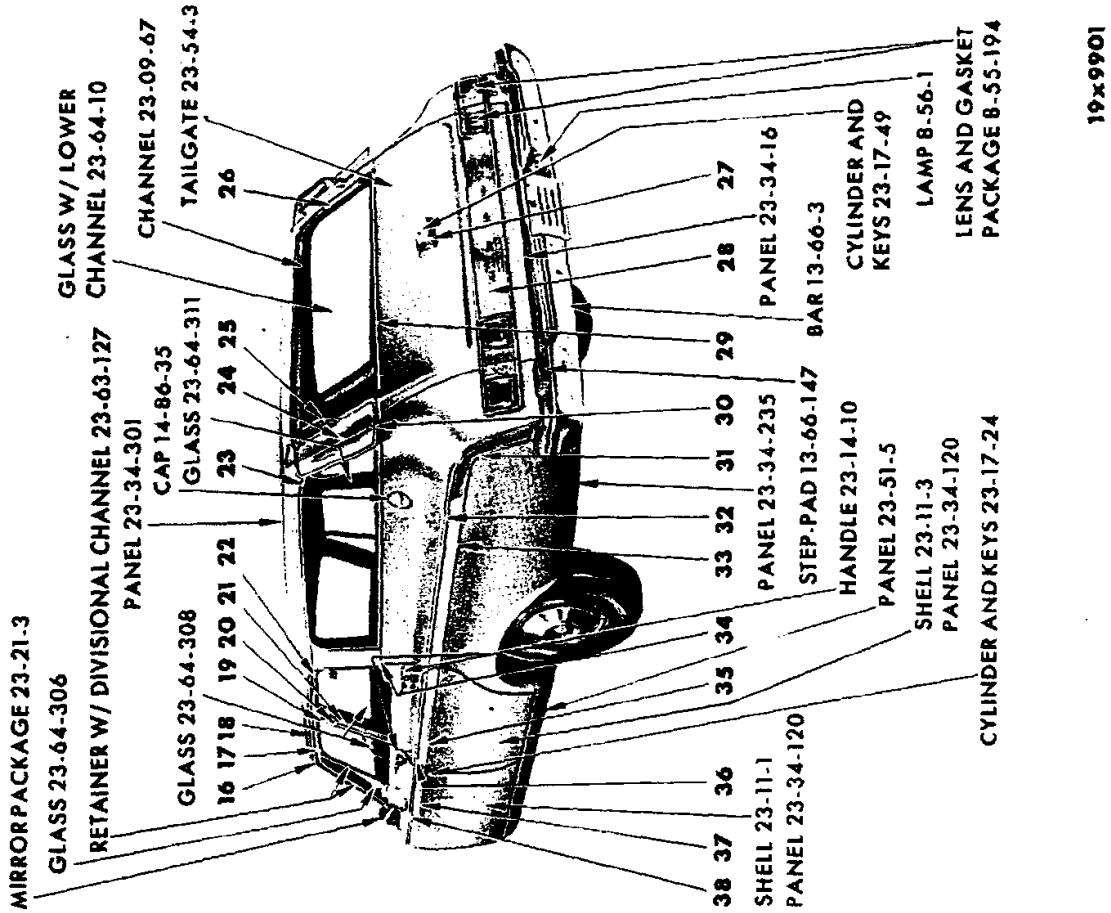

EXTERIOR VIEW - DODGE VDI-2(M) 4 DOOR STATION WAGON

19x9901

REF. NO.	QTY	PART NUMBER	DESCRIPTION	REF. NO.	QTY	PART NUMBER	DESCRIPTION
1	2	2445 097	NAME PLATE, Fender Side (12-15-21)	22	1	2216 036-7	MOULDING, Rear Door Frame Upper (23-23-33)
	8	6001 254	Clip	23	2	2422 471	LOCKINGSTRIP, Quarter Window Glass Weatherstrip Mylar (23-63-110)
2	1	2495 266-7	MOULDING PACKAGE, Fender Side Upper (12-15-2)	24	1	2252 254-5	DEFLECTOR, Roof Panel Outside Air (23-36-134)
	14	6001 497	Retainer	2	167 079	Screw 4 9418 381	Screw
	4	6001 591	Retainer 4 6023 685 Nut	25	1	2482 768-9	HANDLE, Roof Panel Outside Assist (23-36-123)
3	1	2495 720-1	MOULDING PACKAGE, Fender Side Lower (12-15-21)	4	6023 204	Nut and Washer	
	14	6001 497	Retainer	1	2480 980-1	Lower Seal	
	4	6001 591	Retainer 4 6023 685 Nut	2	2482 848-9	Upper Seal	
4	1	2495 722-3	CAP PACKAGE, Fender Side Moulding Rear (12-15-9)	26	1	2480 976-7	MOULDING, Rear Upper Pillar Outside (23-23-60)
	8	6023 685	Nut	8	9417 732	Screw	
5	1	2495 724-5	ORNAMENT PACKAGE, Fender Side Moulding (12-15-21)	27	1	2428 221	BASE, w/Stud, Tailgate Electric Window Regulator Outside Panel (23-54-18)
	10	6023 685	Nut	28	1	2481 257	PANEL and NAME LETTERS, Tailgate Outside Finish Panel (23-23-77)
6	1	2495 716-7	CAP PACKAGE, Fender Side Moulding Front (12-15-9)	5	6000 960	Clip 5 9411 618	Nut
	8	6023 685	Nut	29	1	2448 488	MOULDING PACKAGE, Tailgate Outside Panel Belt (23-23-61)
7	1	2445 112-3	BASE, Fender Top Medallion (12-15-23)	5	6001 435	Clip 5 6024 564	Screw
	2	----	Nut	30	2	2424 626	CAP, Quarter Window Lockingstrip (23-63-117)
8	2	2449 534	MEDALLION, Fender Top (12-15-21)	31	1	2495 480-1	MOULDING PACKAGE, Quarter Panel End (23-23-39)
9	1	2417 825	LETTER, Hood Front Name, Front, "D" (15-06-16)	4	6000 960	Clip	
	1	2417 826	"O"	4	6023 898	Screw 2 6024 651	Screw
	1	2417 827	"D" Center	32	1	2495 442-3	MOULDING PACKAGE, Quarter Panel Upper Front (23-23-39)
	1	2417 828	"G"	10	6001 497	Clip 4 ----	Washer
	1	2417 829	"E"	4	6001 474	Retainer 4 6023 678	Nut
	10	1839 995	Nut	33	1	2495 476-7	MOULDING PACKAGE, Quarter Panel Lower Front (23-23-39)
10	1	2495 253	MOULDING PACKAGE, Hood Front (15-25-2)	14	6001 497	Clip 4 6023 898	Screw
	8	----	Nut	34	1	2299 374	MOULDING PACKAGE, Quarter Panel Belt, Right (23-23-39)
11	1	2495 252	MOULDING PACKAGE, Hood Top (15-25-2)	1	2299 399	MOULDING PACKAGE, Quarter Panel Belt, Left	
	5	9414 977	Nut	4	6001 071	Clip	
	4	2445 120	Spacer	35	1	2495 470-1	MOULDING PACKAGE, Rear Door Rear (23-23-33)
12	1	2218 595	MOULDING, Windshield Outside Finish Lower (23-23-65)	10	6001 497	Clip	
	10	6001 537	Retainer and Screw	2	6001 056	Retainer 2 9417 383	Nut
13	1	2218 594	MOULDING, Windshield Outside Upper (23-23-65)	36	1	2495 322-3	MOULDING PACKAGE, Rear Door Upper (23-23-33)
	8	6001 537	Retainer and Screw	10	6001 497	Clip	
14	1	2218 596-7	MOULDING, Windshield Outside Finish Side (23-23-65)	2	6001 108	Retainer 2 9417 383	Nut
	6	6023 247	Screw	37	1	2495 468-9	MOULDING PACKAGE, Front Door Lower (23-23-39)
15	1	2491 014-5	MOULDING, Windshield Outside Upper Extension (23-23-65)	12	6001 497	Clip	
	6	6024 271	Screw	2	6001 056	Retainer 2 9417 383	Nut
16	2	2422 976	CAP, Roof Drain Trough Moulding Front End (23-59-57)	38	1	2495 326-7	MOULDING PACKAGE, Front Door Upper (23-23-32)
17	1	2218 444-5	MOULDING, Front Door Frame Upper and Front (23-23-32)	10	6001 497	Clip	
18	1	2483 436-7	MOULDING, Roof Drain Trough Side (23-59-61)	2	6001 108	Retainer 2 9417 383	Nut
19	1	2167 998-9	MOULDING, Front Door Frame Rear (23-23-32)	38	1	2495 326-7	MOULDING PACKAGE, Front Door Upper (23-23-32)
20	1	2216 356-7	PANEL, Center Pillar Upper Finish (23-23-16)	10	6001 497	Clip	
21	1	2167 998-9	MOULDING, Rear Door Frame Front (23-23-33)	2	6001 108	Retainer 2 9417 383	Nut

All Packages Include Attaching Parts

Part Type Code is Indicated in Parentheses

EXTERIOR VIEW - DODGE VD1-2(M) 4 DOOR STATION WAGON

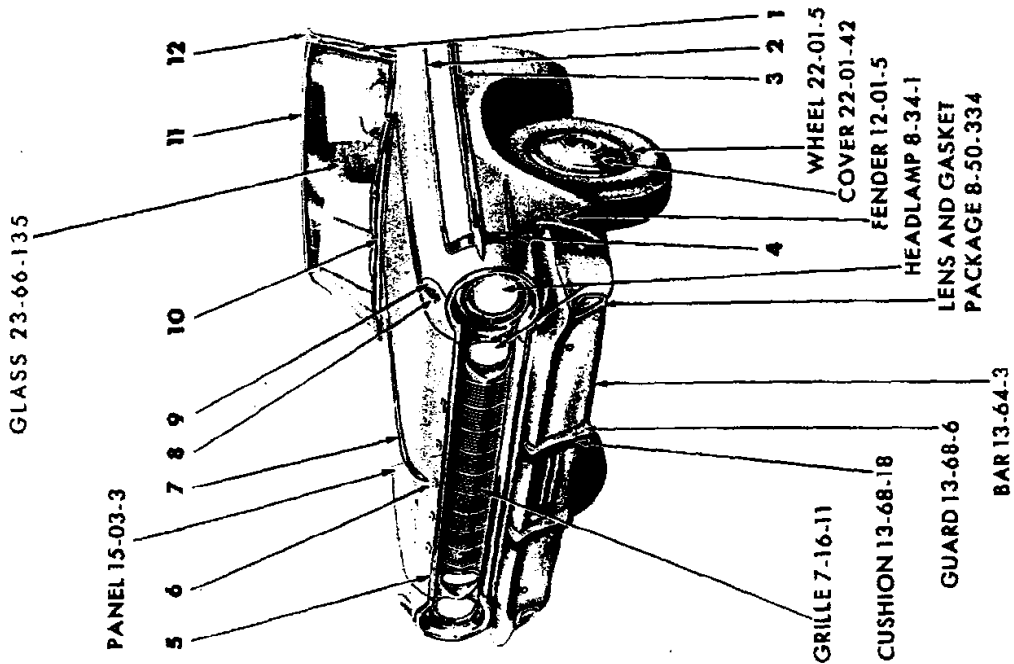
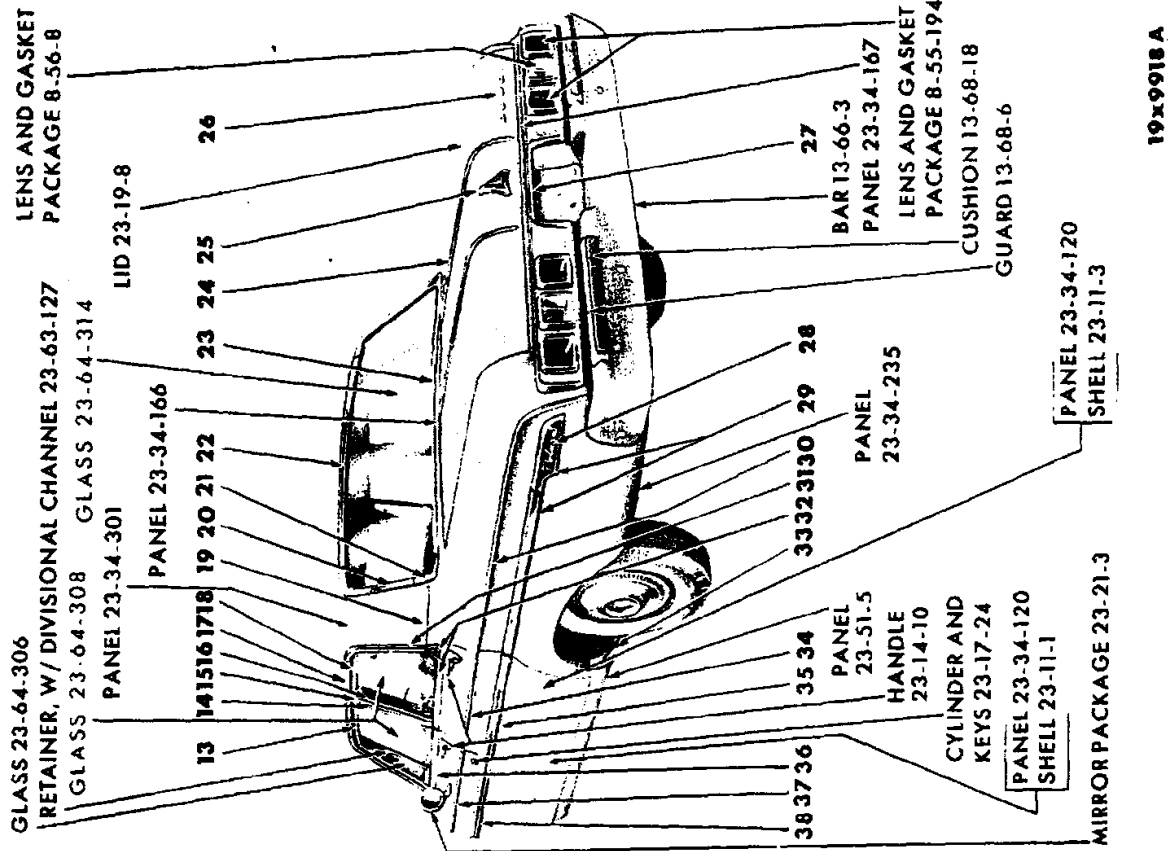

EXTERIOR VIEW - DODGE VDI-2(H) 4 DOOR SEDAN

REF. NO.	QTY	PART NUMBER	DESCRIPTION	REF. NO.	QTY	PART NUMBER	DESCRIPTION
1	1	2218 596-7	MOULDING, Windshield Outside Finish Side (23-23-65)	22	1	2495 269	MOULDING PACKAGE, Rear Window Outside Upper (23-23-52)
	6	6023 247	Screw		6	6001 525	Retainer and Screw
2	1	2495 266-7	MOULDING PACKAGE, Fender Side Upper (12-15-2)	23	1	2480 922	MOULDING, Rear Window Outside Lower (23-23-52)
	4	6001 591	Retainer		6	6023 693	Screw
	14	6001 497	Retainer 4 6023 685 Nut	24	2	2448 583	MOULDING PACKAGE, Deck Lid (23-23-30)
3	1	2495 254-5	MOULDING PACKAGE, Fender Side Intermediate (12-15-2)		12	6001 479	Retainer
	10	6001 563	Retainer		12	9418 877	Nut
	4	6001 595	Clip 4 6023 685 Nut	25	1	2486 313	ORNAMENT, Deck Lid Lock Cylinder (23-17-19)
4	1	2584 128-9	CAP PACKAGE, Fender Side Moulding Front (12-15-9)	26	2	2417 815	"D", Deck Lid Letter (23-19-114)
	12	6023 685	Nut		1	2417 826	"O"
5	1	2495 253	MOULDING PACKAGE, Hood Front (15-25-2)		1	2417 828	"G"
	8	----	Nut		1	2417 829	"E"
	8	6001 087	Retainer, w/Stud		10	152 259	Nut
6	1	2417 825	LETTER, Hood Front Name, D (15-06-16)	27	1	2495 944-5	MOULDING PACKAGE, Deck Lower Panel License Depression (23-23-23)
	1	2417 826	O		6	6024 245	Nut 6 6024 271 Screw
	1	2417 827	D, Center	28	1	2495 698-9	MOULDING PACKAGE, Quarter Panel Lower End (23-23-39)
	1	2417 828	G		4	6001 548	Retainer 4 6023 678 Nut
	1	2417 829	E	29	1	2495 312-3	MOULDING PACKAGE, Quarter Panel Lower, w/Name (23-23-39)
	10	1839 995	Nut		8	6001 563	Clip
7	1	2495 252	MOULDING PACKAGE, Hood Top (15-25-2)		2	6001 595	Retainer
	5	9414 977	Nut 4 2445 120 Spacer		2	6024 279	Nut
8	2	2449 534	MEDALLION, Fender Top (12-15-21)	30	1	2495 304-5	MOULDING PACKAGE, Quarter Panel Upper (23-23-39)
	2	----	Nut		16	6001 497	Clip 4 6024 279 Nut
10	1	2218 595	MOULDING, Windshield Outside Finish Lower (23-23-65)		4	6001 474	Retainer 4 ---- Washer
11	1	2218 594	MOULDING, Windshield Outside Upper (23-23-65)	31	1	2480 620-1	MOULDING, Roof Side Drain Trough Rear (23-59-61)
	8	6001 537	Retainer and Screw		4	6024 271	Screw
12	1	2491 016-7	MOULDING, Windshield Outside Side Upper Extension (23-23-65)	32	1	2495 294-5	MOULDING PACKAGE, Rear Door Belt (23-23-33)
	6	6024 271	Screw		8	6001 495	Clip
13	1	2218 444-5	MOULDING, Front Door Window Frame, Upper and Front (23-23-32)		2	6001 488	Clip 2 116 000 Nut
	4	6022 890	Screw		4	6022 077	Washer 2 9417 621 Nut
14	1	2167 998-9	MOULDING, Front Door Window Frame, Rear (23-23-32)	33	1	2526 994-5	DEFLECTOR, Quarter Panel Wheel Opening Stone (23-34-240)
15	1	2216 356-7	PANEL, Center Pillar Upper Finish (23-23-16)		6	6024 288	Screw
	4	6022 890	Screw	34	1	2495 322-3	MOULDING PACKAGE, Rear Door Upper (23-23-33)
16	1	2167 998-9	MOULDING, Rear Door Window Frame, Front (23-23-33)		10	6001 497	Clip
	4	6022 890	Screw		2	6001 108	Retainer 2 9418 877 Nut
17	1	2495 688-9	MOULDING PACKAGE, Roof Side Drain Trough Front (23-59-61)	35	1	2495 300-1	MOULDING PACKAGE, Rear Door Lower (23-23-33)
	4	6024 271	Screw 8 2484 195 Clip		10	6001 563	Clip
18	1	2216 036-7	MOULDING, Rear Door Window Frame, Upper (23-23-33)		2	6001 562	Retainer 2 9417 621 Nut
19	1	2495 360-1	MOULDING PACKAGE, Quarter Panel Belt (23-23-39)	36	1	2495 316-7	MOULDING PACKAGE, Front Door Belt (23-23-32)
	6	6001 432	Retainer 6 152 259 Nut		10	6001 495	Clip
20	1	2480 918-9	MOULDING, Rear Window Outside Side (23-23-52)		1	2495 326-7	MOULDING PACKAGE, Front Door Upper (23-23-32)
	6	6001 525	Retainer and Screw		10	6001 497	Clip
21	1	2480 920-1	MOULDING, Rear Window Outside Lower Corner (23-23-52)		2	6001 108	Retainer 2 9418 877 Nut
	2	6023 693	Screw	38	1	2495 332-3	MOULDING PACKAGE, Front Door Lower (23-23-32)
					8	6001 563	Clip
					4	6001 562	Retainer
					4	9417 621	Nut

All Packages Include Attaching Parts

Part Type Code is Indicated in Parentheses

EXTERIOR VIEW - DODGE VD1-2(H) 4 DOOR SEDAN



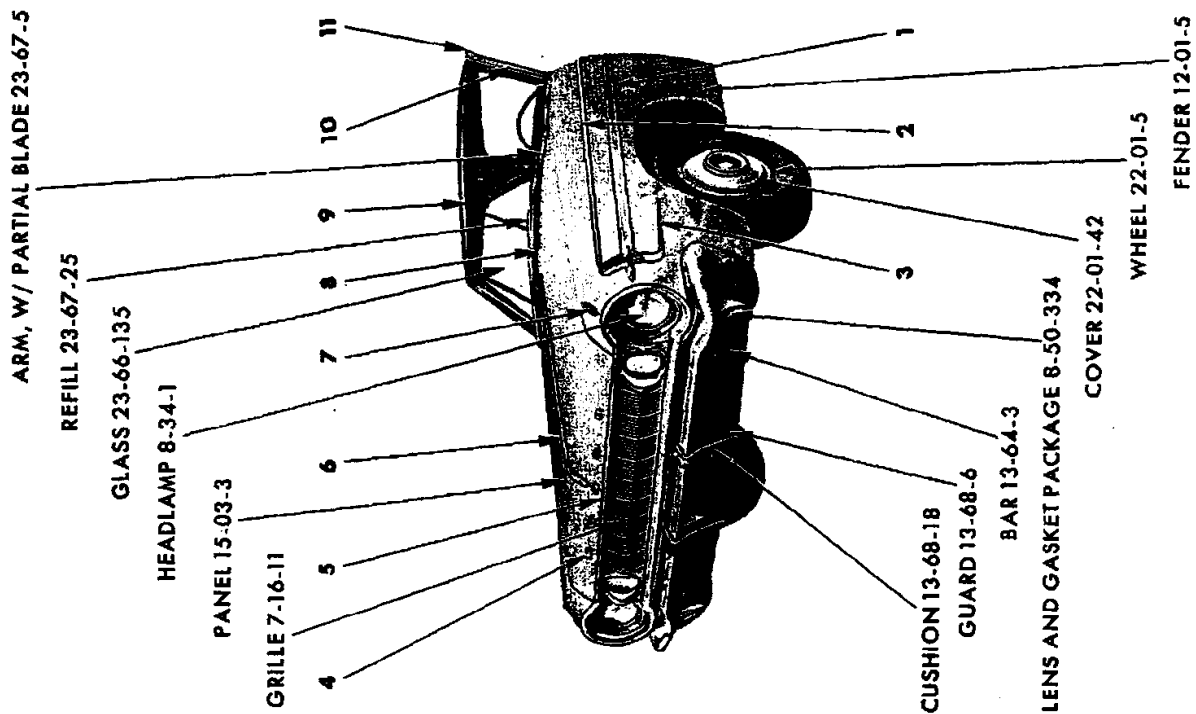
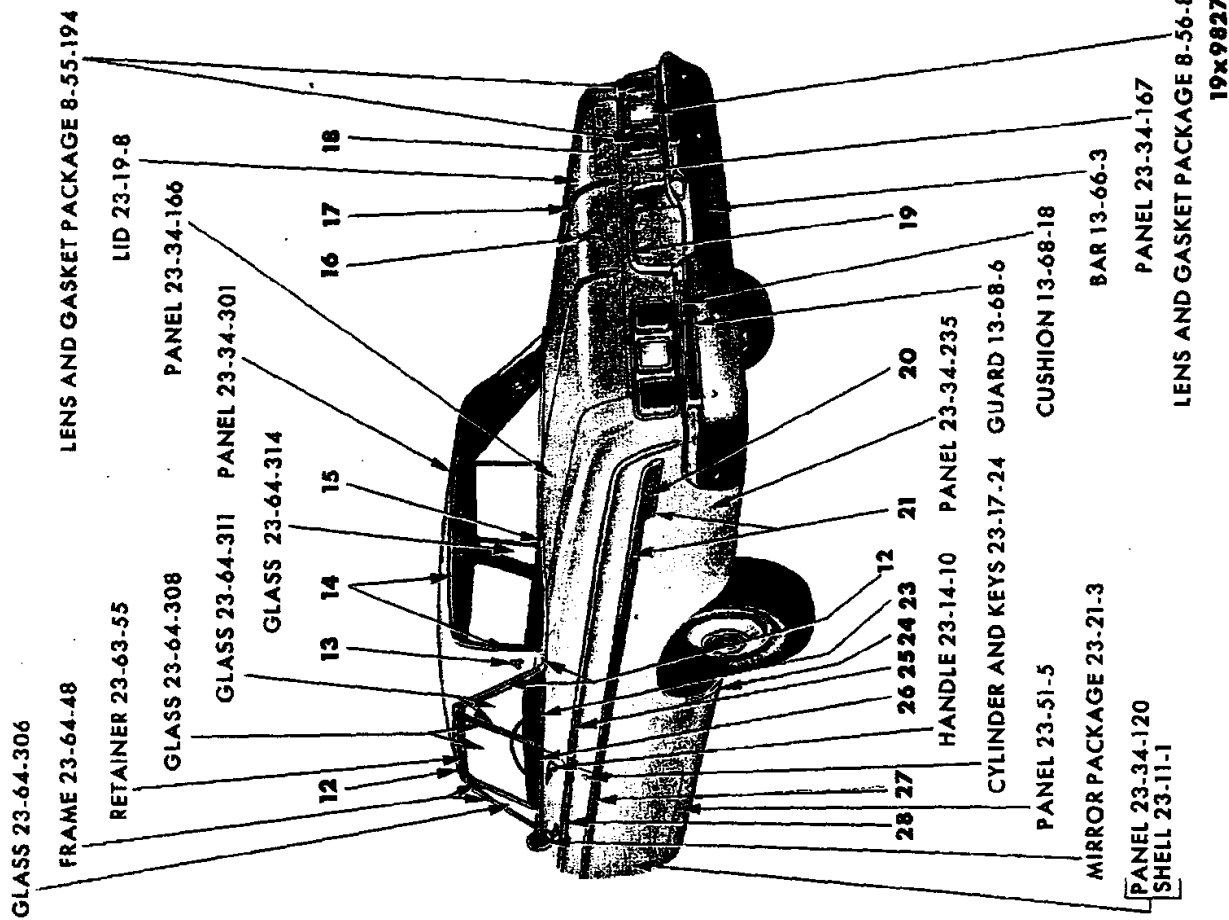

EXTERIOR VIEW - DODGE VDI-2(H) 2 DOOR HARDTOP

REF. NO.	QTY	PART NUMBER	DESCRIPTION
1	1	2495 254-5	MOULDING PACKAGE, Fender Side Intermediate (12-15-2)
	10	6001 563	Retainer
	4	6001 595	Clip
	4	6023 685	Nut
2	1	2495 266-7	MOULDING PACKAGE, Fender Side Upper (12-15-2)
	4	6001 591	Clip
	14	6001 497	Retainer
	4	6023 685	Nut
3	1	2584 128-9	CAP PACKAGE, Fender Side Moulding (12-15-9)
	12	6023 685	Nut
4	1	2417 825	LETTER, Hood Front Name, "D", Front (15-06-16)
	1	2417 826	"O"
	1	2417 827	"D", Center
	1	2417 828	"G"
	1	2417 829	"E"
	10	1839 995	Nut
5	1	2495 253	MOULDING PACKAGE, Hood Front (15-25-2)
	8	----	Nut
	8	6001 087	Retainer, w/Stud
6	1	2495 252	MOULDING PACKAGE, Hood Top (15-25-2)
	5	9414 977	Nut
	4	2445 120	Spacer
7	2	2449 534	MEDALLION, Fender Top (12-15-21)
8	1	2218 595	MOULDING, Windshield Outside Finish Lower (23-23-65)
	10	6001 537	Retainer and Screw
9	1	2218 594	MOULDING, Windshield Outside Upper (23-23-65)
	8	6001 537	Retainer and Screw
10	1	2218 596-7	MOULDING, Windshield Outside Finish Side (23-23-65)
	6	6023 247	Screw
11	1	2492 712-3	MOULDING, Windshield Outside Upper Extension (Narrow Type) (23-23-65)
	6	6024 271	Screw
	1	2491 012-3	MOULDING, Windshield Outside Side Upper Extension (Wide Type) (23-23-65)
12	1	2525 556-7	MOULDING, Roof Side Drain Trough Front and Rear (23-59-61)
	6	2483 716	Clip (w/Vinyl Roof)
	6	2573 062	Clip (w/o Vinyl Roof)
13	2	2482 868	ORNAMENT, Roof Panel Side (23-34-334)
	6	152 259	Nut
14	1	2495 276-7	MOULDING PACKAGE, Rear Window Outside Upper and Side (23-23-52)
	14	6001 084	Retainer and Screw
15	1	2495 274-5	MOULDING PACKAGE, Rear Window Outside Lower (23-23-52)
	10	6001 084	Retainer and Screw
16	1	2486 313	ORNAMENT, Deck Lid Lock Cylinder (23-17-19)

REF. NO.	QTY	PART NUMBER	DESCRIPTION
17	2	2448 583	MOULDING PACKAGE, Deck Lid (23-23-30)
	12	6001 479	Retainer
	12	9418 877	Nut
18	2	2417 825	"D", Deck Lid Letter (23-19-114)
	1	2417 828	"O"
	1	2417 828	"G"
	1	2417 829	"E"
	10	152 259	Nut
19	1	2495 944-5	MOULDING PACKAGE, Deck Lower Panel License Depression (23-23-23)
	6	6024 271	Screw
	6	6024 245	Nut
20	1	2495 698-9	MOULDING PACKAGE, Quarter Panel Lower Rear, w/Name Plate (23-23-39)
	4	6001 548	Retainer
	4	6024 679	Nut
21	1	2495 310-1	MOULDING PACKAGE, Quarter Panel Lower, w/Name Plate (23-23-39)
	16	6001 563	Clip
	2	6024 271	Screw
	2	6024 679	Nut
23	1	2495 320-1	MOULDING PACKAGE, Quarter Panel Belt (23-23-39)
	10	6001 500	Clip
	2	6001 488	Clip
24	1	2526 994-5	DEFLECTOR, Quarter Panel Wheel Opening Stone (23-34-240)
	6	6024 288	Screw
25	1	2495 302-3	MOULDING PACKAGE, Quarter Panel Upper (23-23-39)
	12	6001 497	Clip
	4	6001 474	Retainer
	4	----	Washer
	4	6024 679	Nut
26	1	2495 318-9	MOULDING PACKAGE, Door Belt (23-23-32)
	14	6001 500	Clip
27	1	2495 330-1	MOULDING PACKAGE, Door Lower (23-23-32)
	4	6001 113	Retainer
	4	9417 621	Nut
	10	6001 563	Clip
28	1	2495 324-5	MOULDING PACKAGE, Door Upper (23-23-32)
	2	6001 108	Retainer
	2	9418 877	Nut
	12	6001 497	Clip

All Packages Include Attaching Parts

Part Type Code is Indicated in Parentheses

EXTERIOR VIEW - DODGE VD1-2(H) 2 DOOR HARDTOP

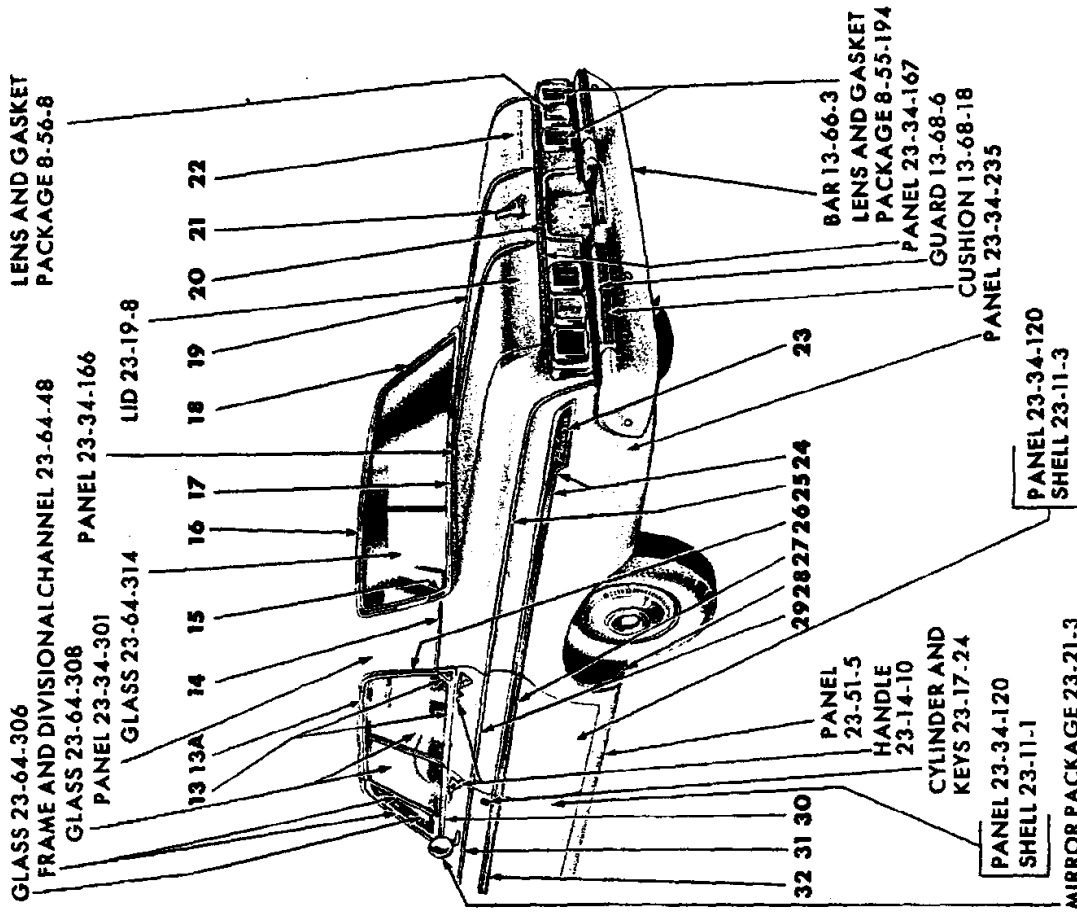

19x9919A

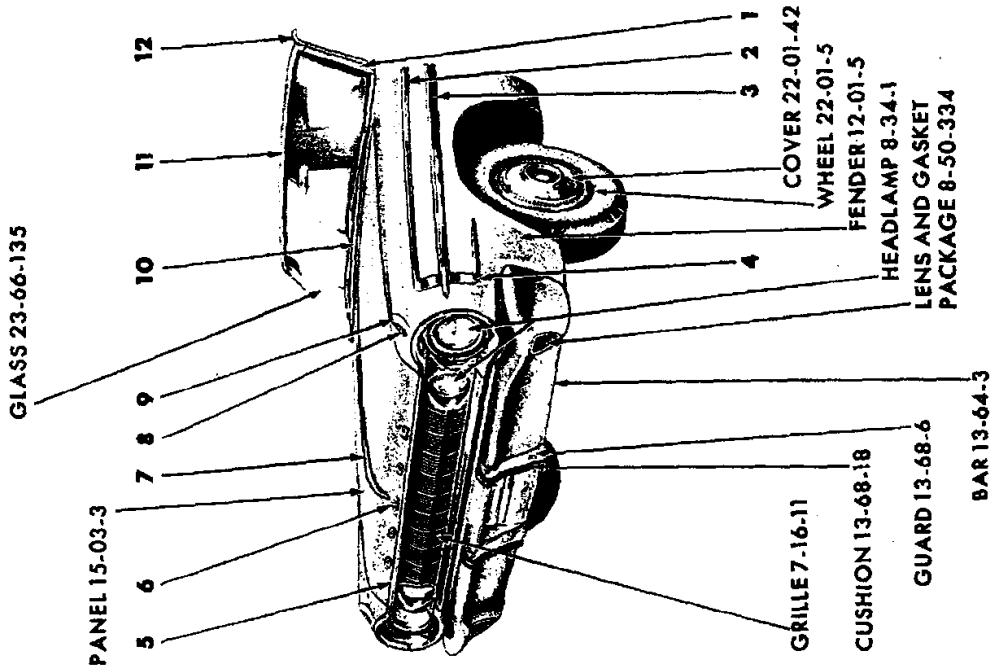

EXTERIOR VIEW - DODGE VD1-2(H) 4 DOOR HARDTOP

REF. NO.	QTY	PART NUMBER	DESCRIPTION	REF. NO.	QTY	PART NUMBER	DESCRIPTION
1	1	2218 596-7	MOULDING, Windshield Outside Finish Side (23-23-65)	17	1	2480 922	MOULDING, Rear Window Outside Lower (23-23-52)
	6	6023 247	Screw		6	6023 693	Screw
2	1	2495 266-7	MOULDING PACKAGE, Fender Side Upper (12-15-2)	18	1	2480 918-9	MOULDING, Rear Window Outside Side (23-23-52)
	4	6001 591	Retainer		6	6001 525	Retainer and Screw
	14	6001 497	Retainer 4 6023 685 Nut	19	2	2448 583	MOULDING PACKAGE, Deck Lid (23-23-30)
3	1	2495 254-5	MOULDING PACKAGE, Fender Side Intermediate (12-15-2)		12	6001 479	Retainer 12 9417 383 Nut
	10	6001 563	Retainer	20	1	2495 944-5	MOULDING PACKAGE, Deck Lower Panel License Depression (23-23-23)
	4	6001 595	Clip 4 6023 685 Nut		6	6024 271	Screw 6 6024 245 Nut
4	1	2584 128-9	CAP PACKAGE, Fender Side Moulding (12-15-9)	21	1	2486 313	ORNAMENT, Deck Lid Lock Cylinder (23-17-19)
	12	6023 685	Nut	22	2	2417 825	"D", Deck Lid Letter (23-19-114)
5	1	2495 253	MOULDING PACKAGE, Hood Front (15-25-2)		1	2417 826	"O"
	8	-----	Nut 8 6001 087 Retainer		1	2417 827	"D" Center
6	1	2417 825	LETTER, Hood Front Name, "D", Front (15-06-16)		1	2417 828	"G"
	1	2417 826	"O"		1	2417 829	"E"
	1	2417 827	"D" Center		10	152 259	Nut
	1	2417 828	"G"	23	1	2495 698-9	MOULDING PACKAGE, Quarter Panel Lower Rear (23-23-39)
	1	2417 829	"E"		4	6001 548	Retainer 4 6023 678 Nut
	10	1839 995	Nut	24	1	2495 312-3	MOULDING PACKAGE, Quarter Panel Lower, w/Name (23-23-39)
7	1	2495 252	MOULDING PACKAGE, Hood Top (15-25-2)		8	6001 563	Clip
	5	9414 977	Nut 4 2445 120 Spacer		2	6001 595	Retainer 2 6023 678 Nut
8	2	2449 534	MEDALLION, Fender Top (12-15-21)	25	1	2495 304-5	MOULDING PACKAGE, Quarter Panel Upper (23-23-39)
9	1	2445 112-3	BASE, Fender Top Medallion (12-15-23)		6	6001 497	Clip 4 ----- Washer
	2	-----	Nut		4	6001 474	Retainer 4 6023 678 Nut
10	1	2218 595	MOULDING, Windshield Outside Finish Lower (23-23-65)	26	1	2480 620-1	MOULDING, Roof Side Drain Trough Rear (23-59-61)
	10	6001 537	Retainer and Screw		4	6024 271	Screw
11	1	2218 594	MOULDING, Windshield Outside Upper (23-23-65)	27	1	2495 300-1	MOULDING PACKAGE, Rear Door Lower (23-23-33)
	8	6001 537	Retainer and Screw		10	6001 563	Clip
12	1	2491 014-5	MOULDING, Windshield Outside Side Upper Extension (23-23-65)		2	6001 562	Retainer 2 9417 621 Nut
	6	6024 271	Screw	28	1	2526 994-5	DEFLECTOR, Quarter Panel Wheel Opening Stone (23-34-240)
13	1	2495 292-3	MOULDING PACKAGE, Rear Door Belt (23-23-33)		6	6024 288	Screw
	8	6001 495	Clip	29	1	2495 322-3	MOULDING PACKAGE, Rear Door Upper (23-23-33)
	2	6001 488	Clip 2 116 000 Nut		10	6001 497	Clip
	4	6022 077	Washer 2 9417 621 Nut		2	6001 108	Retainer 2 9417 383 Nut
13A	1	2495 688-9	MOULDING PACKAGE, Roof Side Train Trough Front (23-59-61)	30	1	2495 314-5	MOULDING PACKAGE, Front Door Belt (23-23-32)
	4	6024 271	Screw		10	6001 495	Clip
	8	2484 195	Clip	31	1	2495 326-7	MOULDING PACKAGE, Front Door Upper (23-23-32)
14	1	2495 360-1	MOULDING PACKAGE, Quarter Panel Belt (23-23-39)		10	6001 497	Clip
	6	6001 432	Retainer 6 152 259 Nut		2	6001 108	Retainer 2 9417 383 Nut
15	1	2480 920-1	MOULDING, Rear Window Outside Lower Corner (23-23-52)	32	1	2495 332-3	MOULDING PACKAGE, Front Door Lower (23-23-32)
	2	6023 693	Screw		8	6001 563	Clip
16	1	2495 269	MOULDING PACKAGE, Rear Window Outside Upper (23-23-52)		4	6001 562	Retainer 4 9417 621 Nut
	6	6001 525	Retainer and Screw				

All Packages Include Attaching Parts

Part Type Code is Indicated in Parentheses

EXTERIOR VIEW - DODGE VD1-2(H) 4 DOOR HARDTOP

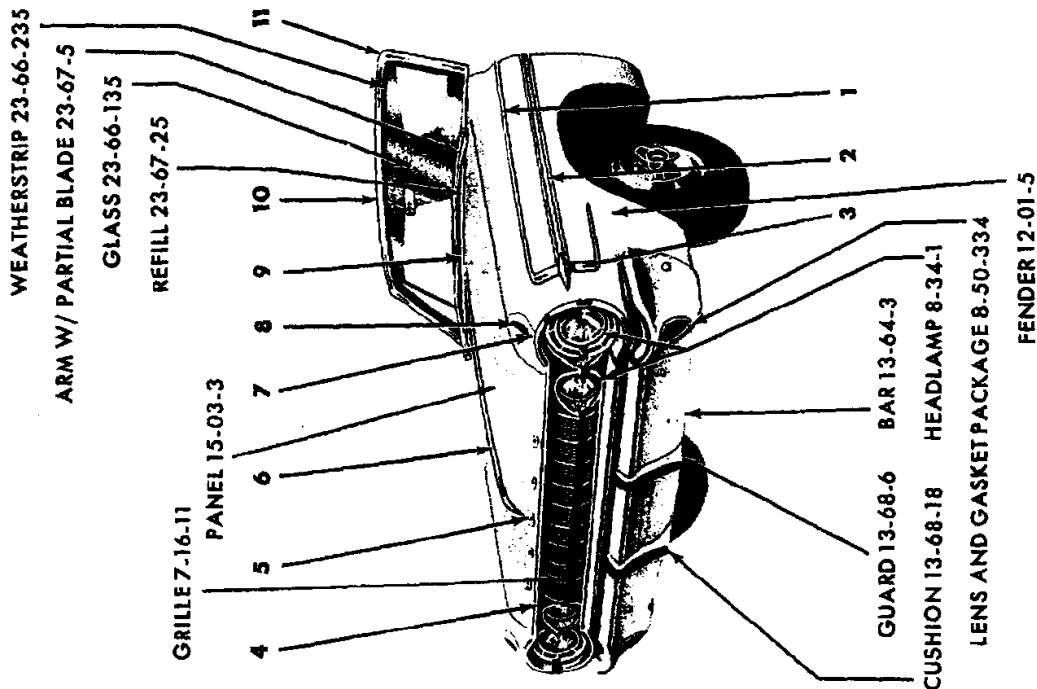
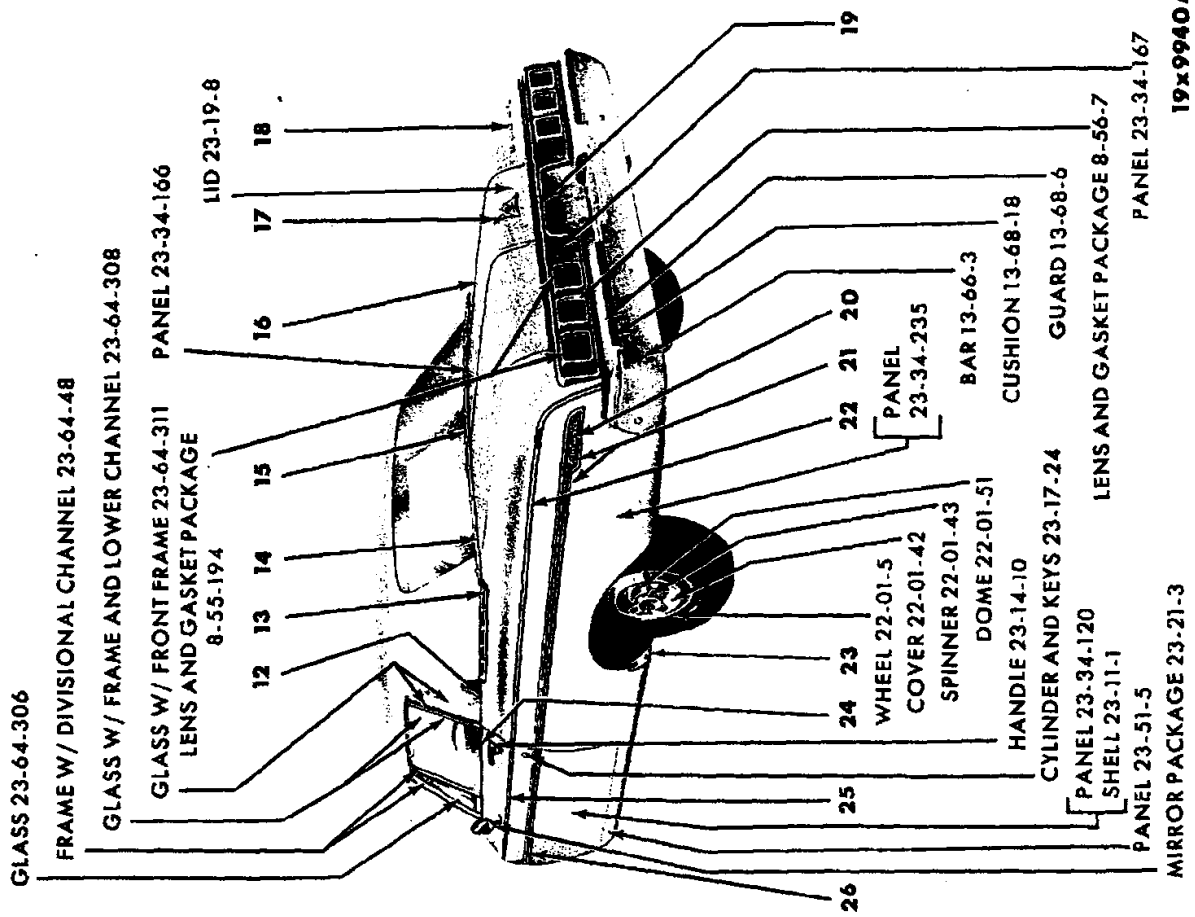

EXTERIOR VIEW - DODGE VD2(H) CONVERTIBLE COUPE

REF. NO.	QTY	PART NUMBER	DESCRIPTION
1	1	2495 266-7	MOULDING PACKAGE, Fender Side Upper (12-15-2)
	4	6001 591	Retainer
	14	6001 497	Retainer
	4	6023 685	Nut
2	1	2495 254-5	MOULDING PACKAGE, Fender Side Intermediate (12-15-2)
	10	6001 563	Retainer
	4	6001 595	Clip
	4	6023 685	Nut
3	1	2495 128-9	CAP PACKAGE, Fender Side Moulding Front (12-15-9)
	12	6023 685	Nut
4	1	2495 253	MOULDING PACKAGE, Hood Front (15-25-2)
	8	-----	Nut
	8	6001 087	Retainer
5	1	2417 825	LETTER, Hood Front Name, "D", Front (15-06-16)
	1	2417 826	"O"
	1	2417 827	"D", Center
	1	2417 828	"G"
	1	2417 829	"E"
	10	1839 995	Nut
6	1	2495 252	MOULDING PACKAGE, Hood Top (15-25-2)
	5	9414 977	Nut
	4	2445 120	Spacer
7	1	2445 112-3	BASE, Fender Top Medallion (12-15-23)
	2	-----	Nut
8	2	2449 534	MEDALLION, Fender Top (12-15-21)
9	1	2218 595	MOULDING, Windshield Outside Finish Lower (23-23-65)
	10	6001 537	Retainer and Screw
10	1	2482 898-9	MOULDING, Windshield Header Outside (23-23-65)
	7	162 402	Screw
	7	-----	Seal
11	1	2218 596-7	MOULDING, Windshield Outside Finish Side (23-23-65)
	6	6023 247	Screw
12	1	2495 362-3	MOULDING PACKAGE, Quarter Panel Belt Front (23-23-39)
	8	6001 500	Retainer
13	1	2495 364-5	MOULDING PACKAGE, Quarter Panel Belt Rear (23-23-39)
	14	6024 472	Fastener
14	1	2448 458-9	MOULDING PACKAGE, Deck Upper Panel (23-23-31)
	10	6024 477	Fastener
15	1	2448 456	COVER PACKAGE, Deck Opening Upper Panel Moulding Joint (23-23-41)
	1	6024 477	Fastener

All Packages include Attaching Parts

REF. NO.	QTY	PART NUMBER	DESCRIPTION
16	2	2448 583	MOULDING PACKAGE, Deck Lid Top (23-23-30)
	12	6001 479	Retainer
	12	9418 877	Nut
17	1	2486 313	ORNAMENT, Deck Lid Lock Cylinder (23-17-19)
18	2	2417 825	"D", Deck Lid Letter (23-19-114)
	1	2417 826	"O"
	1	2417 828	"G"
	1	2417 829	"E"
	10	152 259	Nut
19	1	2495 944-5	MOULDING PACKAGE, Deck Lower Panel License Depression (23-23-23)
	6	6024 245	Nut
	6	6024 271	Screw
20	1	2495 698-9	MOULDING PACKAGE, Quarter Panel Lower Rear, w/Name (23-23-39)
	4	6001 548	Retainer
	4	6024 679	Nut
21	1	2495 310-1	MOULDING PACKAGE, Quarter Panel Lower, w/Name (23-23-39)
	2	6024 271	Screw
	2	6001 595	Retainer
	16	6001 563	Clip
	2	6024 279	Nut
22	1	2495 302-3	MOULDING PACKAGE, Quarter Panel Upper (23-23-39)
	4	-----	Washer
	4	6001 474	Retainer
	24	6001 497	Clip
	4	6024 279	Nut
23	1	2526 994-5	DEFLECTOR, Quarter Panel Wheel Opening Stone (23-34-240)
	6	6024 288	Screw
24	1	2495 318-9	MOULDING PACKAGE, Door Belt (23-23-32)
	14	6001 500	Clip
25	1	2495 324-5	MOULDING PACKAGE, Door Upper (23-23-32)
	2	6001 108	Retainer
	2	6001 576	Retainer
	2	6024 676	Washer
	14	6001 497	Clip
	2	9418 877	Nut
	2	9419 629	Screw
26	1	2495 330-1	MOULDING PACKAGE, Door Lower (23-23-32)
	4	6001 113	Retainer
	2	6001 578	Retainer
	2	6024 676	Washer
	4	9417 621	Nut
	10	6001 563	Clip
	2	9419 629	Screw

Part Type Code is Indicated in Parentheses

# 1964 PASSENGER CAR PARTS CATALOG

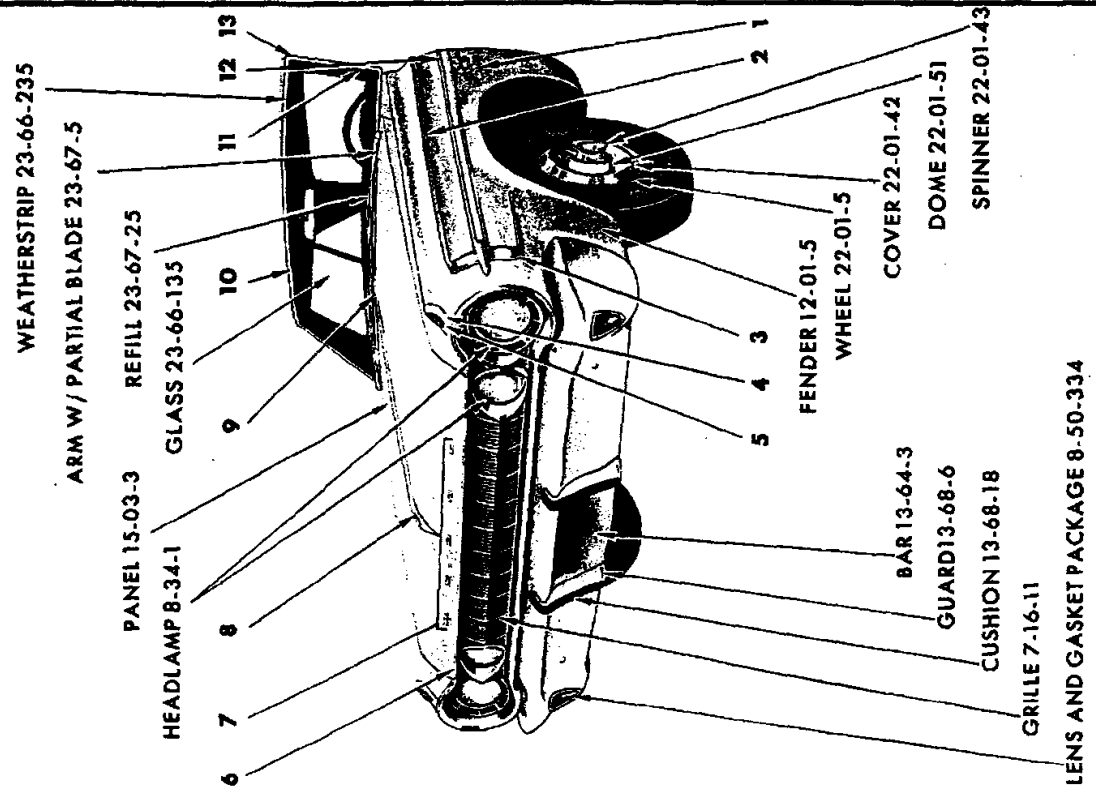
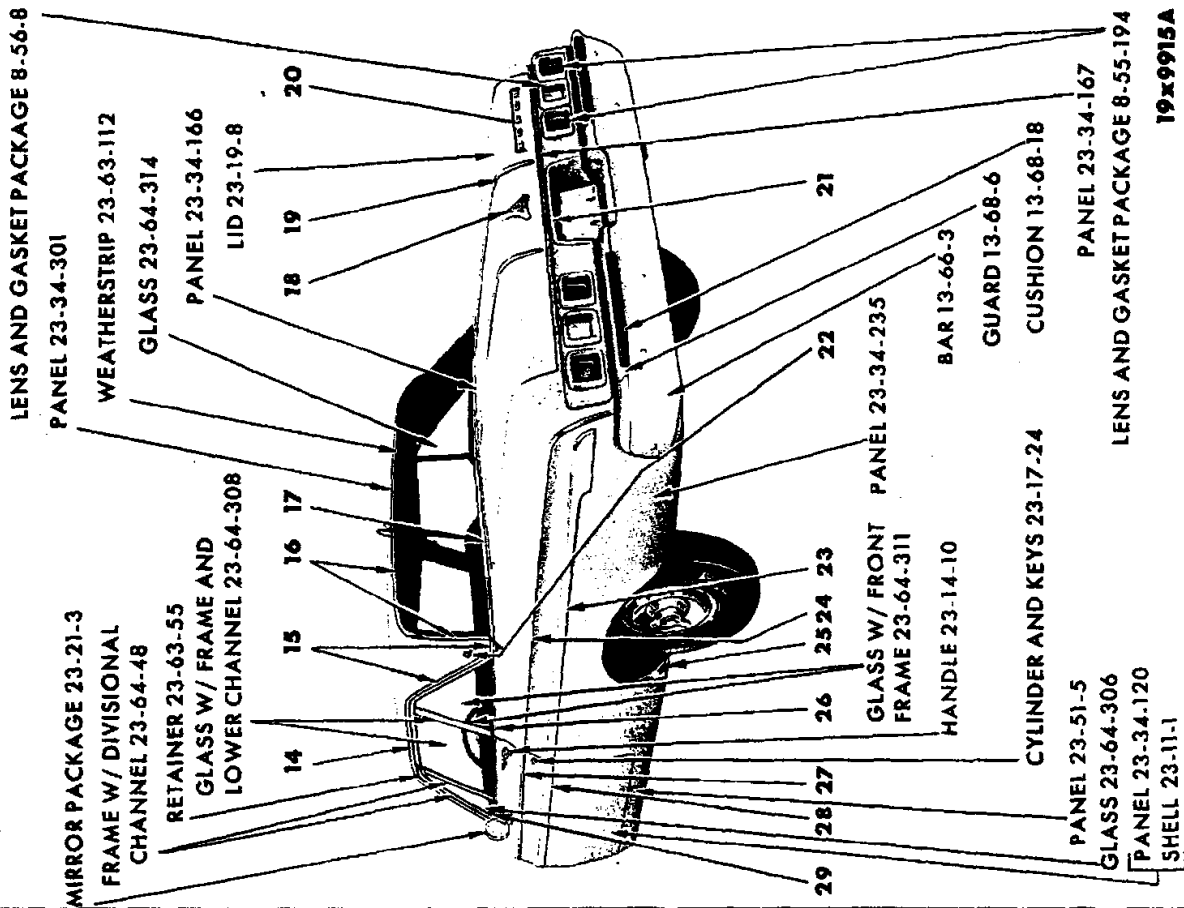

EXTERIOR VIEW - DODGE VD2(P) 2 DOOR HARDTOP

REF. NO.	QTY	PART NUMBER	DESCRIPTION	REF. NO.	QTY	PART NUMBER	DESCRIPTION
1	2	2255 628	NAME PLATE, Fender Side (12-15-21)	15	1	2525 556	MOULDING PACKAGE, Roof Side Drain Trough Rear (23-59-61)
	2	6000 960	Clip		6	6024 271	Screw 2 ---- Nut
	2	-----	Washer 2 6023 097 Nut	16	1	2495 276-7	MOULDING PACKAGE, Rear Window Outside Upper and Side (23-23-52)
2	1	2495 266-7	MOULDING PACKAGE, Fender Side Upper (12-15-2)		14	6001 084	Retainer and Screw
	4	6001 591	Retainer	17	1	2495 274-5	MOULDING PACKAGE, Rear Window Outside Lower (23-23-52)
	14	6001 497	Retainer 4 6023 685 Nut		10	6001 084	Retainer and Screw
3	1	2584 130-1	CAP PACKAGE, Fender Side Moulding Front (12-15-9)	18	1	2486 313	ORNAMENT, Deck Lid Lock Cylinder (23-17-19)
	12	6023 685	Nut	19	2	2448 583	MOULDING PACKAGE, Deck Lid (23-23-30)
4	1	2445 112-3	BASE, Fender Top Medallion (12-15-23)		12	6001 479	Retainer 12 9417 383 Nut
	2	-----	Nut	20	2	2417 825	"D", Deck Lid Letter (23-19-114)
5	2	2449 534	MEDALLION, Fender Top (12-15-21)		1	2417 826	"O"
6	1	2495 253	MOULDING PACKAGE, Hood Front (15-25-2)		1	2417 828	"G"
	8	6001 087	Retainer 8 ---- Nut		1	2417 829	"E"
7	1	2417 825	LETTER, Hood Front Name, "D", Front (15-06-16)		10	152 259	Nut
	1	2417 826	"O"	21	1	2495 944-5	MOULDING PACKAGE, Deck Lower Panel License Depression (23-23-23)
	1	2417 827	"D" Center		6	6024 245	Nut
	1	2417 828	"G"		6	6024 271	Screw
	1	2417 829	"E"	22	2	2482 868	ORNAMENT, Roof Panel Side (23-34-334)
	10	1839 995	Nut		6	152 259	Nut
8	1	2495 252	MOULDING PACKAGE, Hood Top (15-25-2)		6	6024 271	Screw
	5	9414 977	Nut 4 2445 120 Spacer	23	1	2495 916-7	MOULDING PACKAGE, Quarter Panel Lower (23-23-39)
9	1	2218 595	MOULDING, Windshield Outside Finish Lower (23-23-65)		20	6001 563	Retainer
	10	6001 537	Retainer and Screw		2	6001 595	Retainer
10	1	2218 594	MOULDING, Windshield Outside Upper (23-23-65)		4	6001 548	Retainer 6 6023 678 Nut
	8	6001 537	Retainer and Screw	24	1	2495 302-3	MOULDING PACKAGE, Quarter Panel Upper (23-23-39)
11	1	2218 596-7	MOULDING, Windshield Outside Finish Side (23-23-65)		24	6001 497	Clip 4 ---- Washer
	6	6023 247	Screw		4	6001 474	Retainer 4 6023 678 Nut
12	1	2525 550-1	MOULDING PACKAGE, Fender Side Intermediate (12-15-2)	25	1	2526 994-5	DEFLECTOR, Quarter Panel Wheel Opening Stone (23-34-240)
	10	6001 563	Retainer		6	6024 288	Screw
	4	6001 595	Clip 4 ---- Nut	26	1	2495 320-1	MOULDING PACKAGE, Quarter Panel Belt (23-23-39)
13	1	2492 712-3	MOULDING, Windshield Outside Side Upper Extension (Narrow Type) (23-23-65)		10	6001 500	Clip 2 6001 488 Clip
	1	2491 012-3	MOULDING, Windshield Outside Side Upper Extension (Wide Type)	27	1	2495 324-5	MOULDING PACKAGE, Door Upper (23-23-32)
	6	6024 271	Screw		14	6001 497	Clip 2 9417 383 Nut
14	1	2495 906-7	MOULDING, Roof Side Drain Trough Front (23-59-61)		2	6001 108	Retainer 2 9417 629 Screw
	6	2483 716	Clip (w/Vinyl Roof)		2	6001 576	Retainer 2 6024 676 Washer
	6	2573 062	Clip (w/o Vinyl Roof)	28	1	2495 918-9	MOULDING PACKAGE, Door Lower (23-23-32)
					2	6001 562	Retainer 2 9417 621 Nut
					10	6001 563	Retainer 2 9419 629 Screw
					2	6001 578	Retainer 2 6024 676 Washer
				29	1	2495 318-9	MOULDING PACKAGE, Door Belt (23-23-32)
					14	6001 500	Clip

All Packages Include Attaching Parts

Part Type Code is Indicated in Parentheses

EXTERIOR VIEW - DODGE VD2(P) 2 DOOR HARDTOP



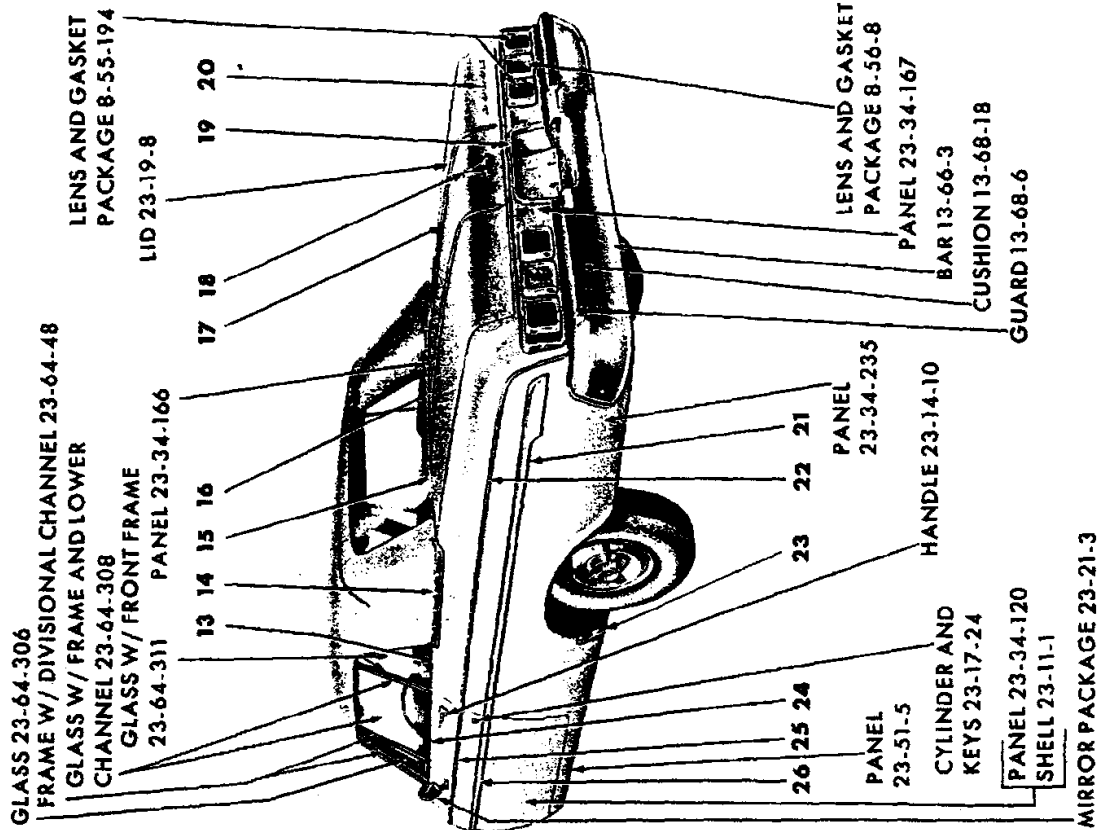

19x9916A

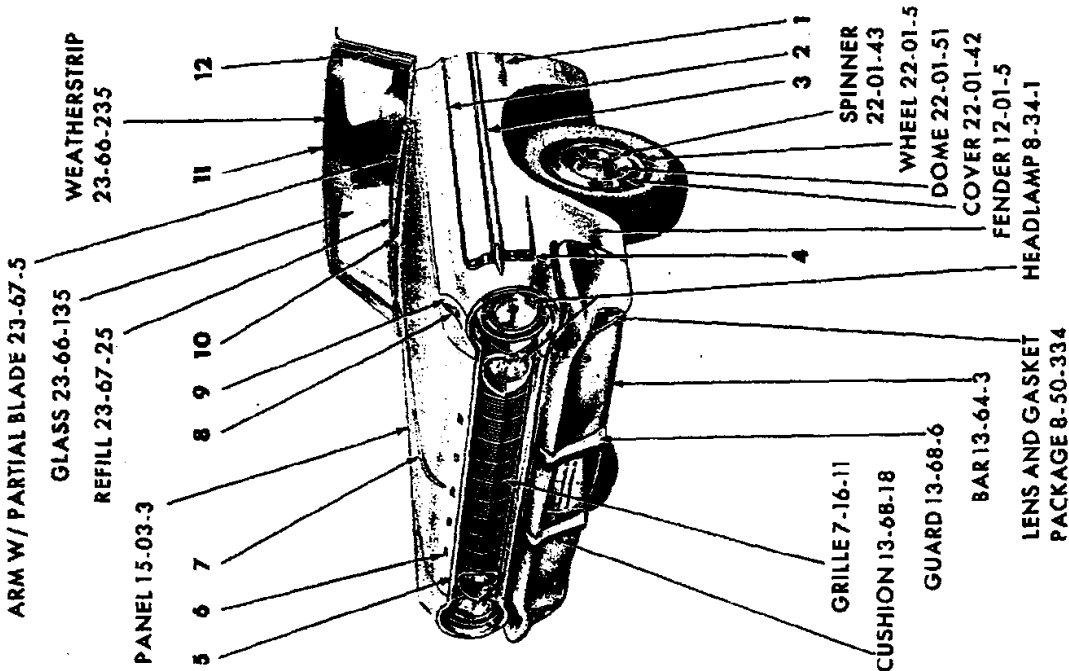

EXTERIOR VIEW - DODGE VD2(P) CONVERTIBLE COUPE

REF. NO.	QTY	PART NUMBER	DESCRIPTION
1	2	2255 628	NAME PLATE, Fender Side (12-15-21)
	2	6000 960	Clip
	2	-----	Washer 2 6023 097 Nut
2	1	2495 266-7	MOULDING PACKAGE, Fender Side Upper (12-15-2)
	4	6001 591	Retainer
	14	6001 497	Retainer 4 6023 685 Nut
3	1	2525 550-1	MOULDING PACKAGE, Fender Side Intermediate (12-15-2)
	10	6001 563	Retainer
	4	6001 595	Clip 4 ----- Nut
4	1	2584 130-1	CAP PACKAGE, Fender Side Moulding Front (12-15-9)
	12	6023 685	Nut
5	1	2495 253	MOULDING PACKAGE, Hood Front (15-25-2)
	8	-----	Nut
	8	6001 087	Retainer, w/Stud
6	1	2417 825	LETTER, Hood Front Name, Front, "D" (15-06-16)
	1	2417 826	"O"
	1	2417 827	"D", Center
	1	2417 828	"G"
	1	2417 829	"E"
	10	1839 995	Nut
7	1	2495 252	MOULDING PACKAGE, Hood Top (15-25-2)
	4	2445 120	Spacer 5 9414 977 Nut
8	2	2449 534	MEDALLION, Fender Top (12-15-21)
9	1	2445 112-3	BASE, Fender Top Medallion (12-15-23)
	2	-----	Nut
10	1	2218 595	MOULDING, Windshield Outside Finish Lower (23-23-65)
	10	6001 537	Retainer and Screw
11	1	2482 898-9	MOULDING, Windshield Header Outside (23-23-65)
	7	162 402	Screw 7 2480 766 Seal
12	1	2218 596-7	MOULDING, Windshield Outside Finish Side (23-23-65)
	6	6023 247	Screw
13	1	2495 362-3	MOULDING PACKAGE, Quarter Panel Belt Front (23-23-39)
	8	6001 500	Retainer

REF. NO.	QTY	PART NUMBER	DESCRIPTION
14	1	2495 364-5	MOULDING PACKAGE, Quarter Panel Belt Rear (23-23-39)
	14	6024 472	Fastener
15	1	2448 458-9	MOULDING PACKAGE, Deck Upper Panel (23-23-31)
	10	6024 477	Fastener
16	1	2448 456	COVER PACKAGE, Deck Opening Upper Panel Moulding Joint (23-23-41)
	1	6024 477	Fastener
17	2	2448 538	MOULDING PACKAGE, Deck Lid (23-23-30)
	12	6001 479	Retainer 12 9418 877 Nut
18	1	2486 313	ORNAMENT, Deck Lid (23-17-19)
19	1	2495 944-5	MOULDING PACKAGE, Deck Lower Panel License Depression (23-23-23)
	6	6024 245	Nut 6 6024 271 Screw
20	2	2417 825	"D", Deck Lid Letter (23-19-114)
	1	2417 826	"O"
	1	2417 828	"G"
	1	2417 829	"E"
	10	152 259	Nut
21	1	2495 916-7	MOULDING PACKAGE, Quarter Panel Lower (23-23-39)
	20	6001 563	Retainer
	2	6001 595	Retainer
	4	6001 548	Retainer 6 6024 679 Nut
22	1	2495 302-3	MOULDING PACKAGE, Quarter Panel Upper (23-23-39)
	24	6001 497	Clip 4 ----- Washer
	4	6001 474	Retainer 4 6024 679 Nut
23	1	2526 994-5	DEFLECTOR, Quarter Panel Wheel Opening Stone (23-34-240)
	6	6024 288	Screw
24	1	2495 318-9	MOULDING PACKAGE, Door Belt (23-23-32)
	14	6001 500	Clip
25	1	2495 324-5	MOULDING PACKAGE, Door Upper (23-23-32)
	2	6001 108	Retainer 2 9418 877 Nut
	2	6001 576	Retainer 14 6001 497 Clip
	2	6024 676	Washer 2 9419 629 Screw
26	1	2495 918-9	MOULDING PACKAGE, Door Lower (23-23-32)
	2	6001 562	Retainer 2 9417 621 Nut
	10	6001 563	Retainer 2 9419 629 Screw
	2	6001 578	Retainer 2 6024 676 Washer

All Packages Include Attaching Parts

Part Type Code is Indicated in Parentheses

EXTERIOR VIEW - DODGE VD2(P) CONVERTIBLE COUPE

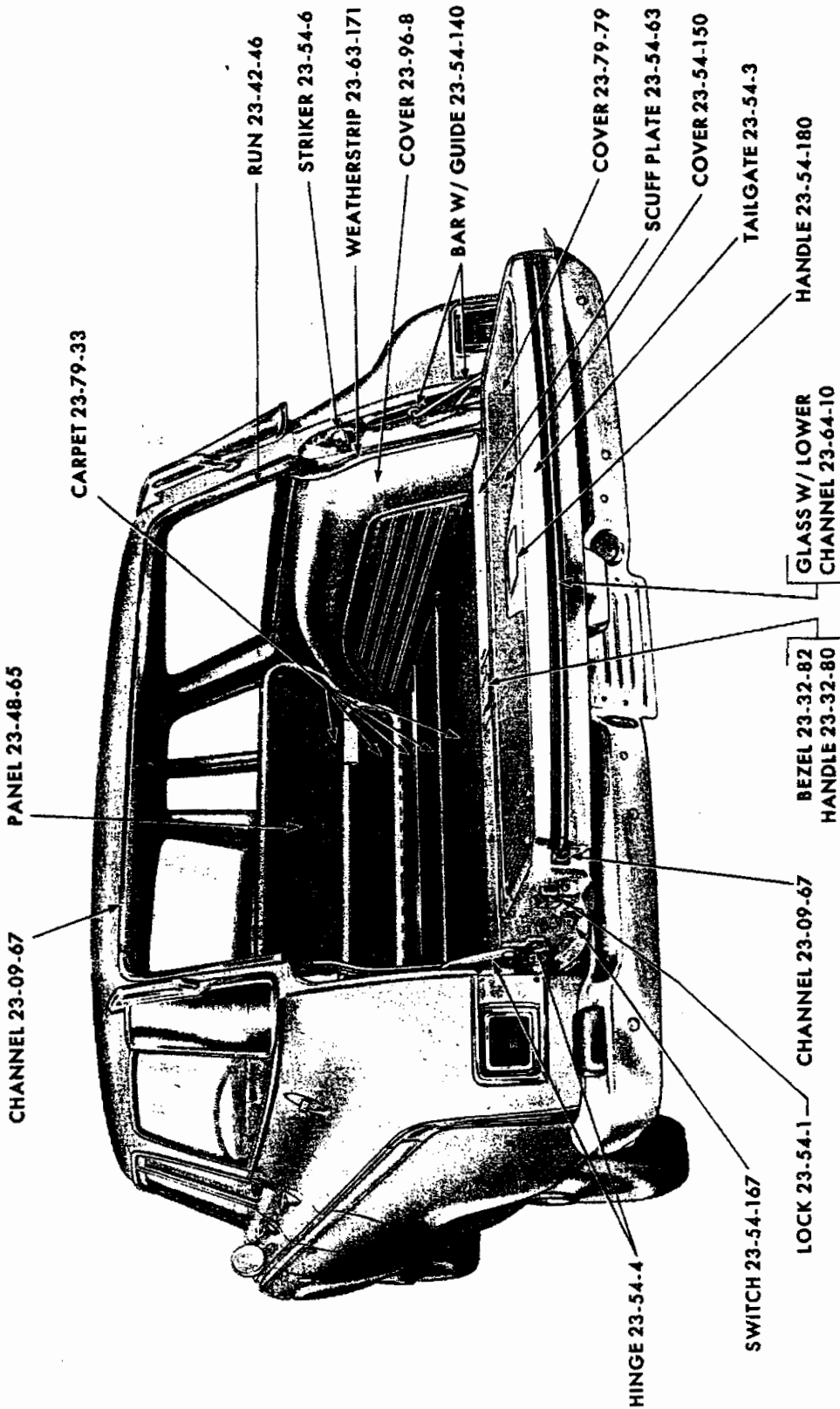

19x9897

REAR INTERIOR VIEW - DODGE VD1-2(M) STATION WAGON



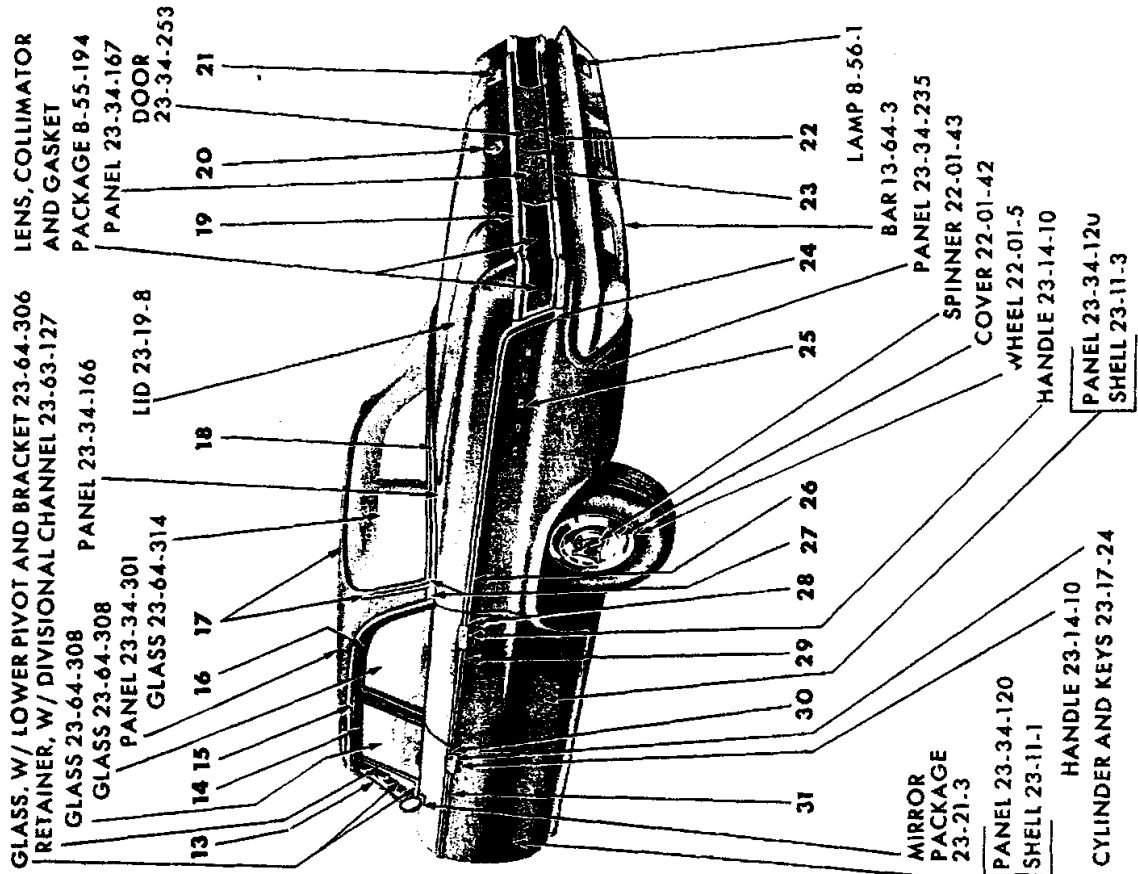

19x9857A

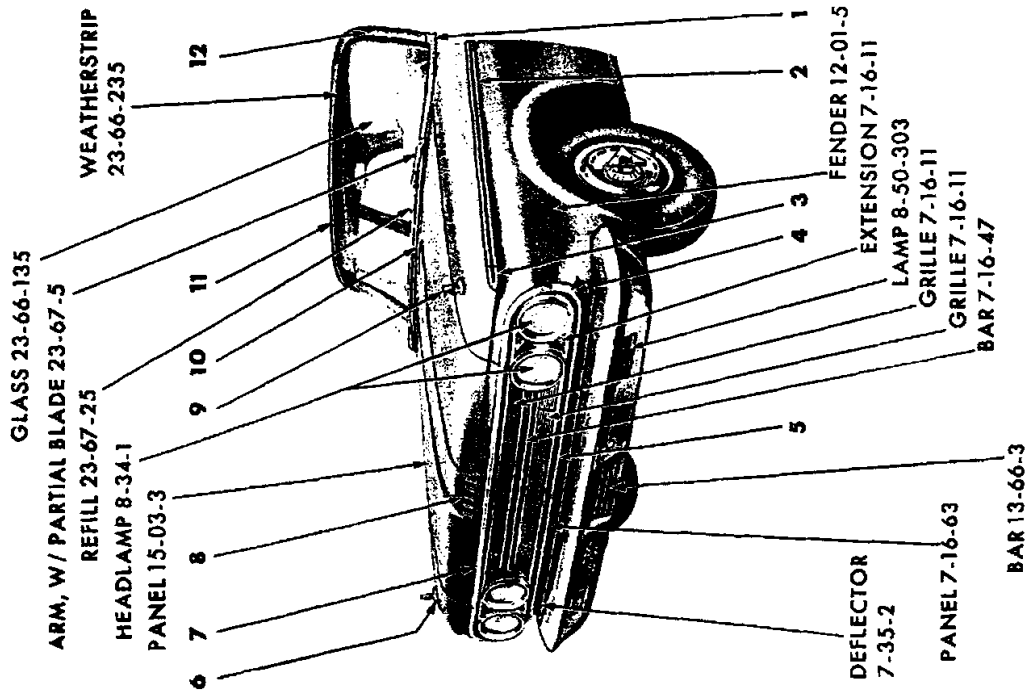

EXTERIOR VIEW - DODGE V8(5) 4 DOOR SEDAN

REF. NO.	QTY	PART NUMBER	DESCRIPTION	REF. NO.	QTY	PART NUMBER	DESCRIPTION
1	1	2196 272-3	MOULDING PACKAGE, Windshield Outside Finish Lower End (23-23-65)	18	1	2495 278	MOULDING PACKAGE, Rear Window Lower (23-23-52)
	2	274 411	Screw		7	6001 528	Clip
	8	6022 010	Screw	19	1	2495 287	MOULDING PACKAGE, Deck Lid (23-23-30)
2	1	2495 186-7	MOULDING PACKAGE, Fender Side (12-15-2)		10	6001 518	Retainer
	4	6001 613	Retainer		10	----	Nut
	10	6001 522	Retainer	20	1	2486 344	ORNAMENT, Deck Lid Lock Cylinder (23-17-17)
	10	----	Nut	21	1	2445 097	NAME PLATE, Deck Lid (23-19-114)
3	2	2495 186	CAP PACKAGE, Fender Side Moulding (12-15-9)		3	152 259	Nut
	2	----	Nut		1	6000 050	Clip
4	1	2448 532-3	MOULDING PACKAGE, Fender Radiator Grille Opening (12-15-2)	22	1	2495 453	MOULDING PACKAGE, Deck Lower Panel Filler Door (23-23-23)
	12	116 000	Nut		2	6001 517	Retainer
	2	----	Nut		2	446 618	Nut
	2	187 121	Screw	23	1	2495 288-9	MOULDING PACKAGE, Deck Lower Panel (23-23-23)
5	1	2495 152	MOULDING PACKAGE, Radiator Grille Lower Panel (7-16-36)		4	6001 517	Retainer
	8	6001 450	Retainer		4	446 618	Nut
6	1	2445 132-3	BASE, Fender Top Ornament (12-15-23)	24	1	2495 422-3	MOULDING PACKAGE, Quarter Panel Rear (23-23-39)
	2	6023 201	Nut		6	6022 052	Seal
7	1	2448 530	MOULDING PACKAGE, Hood Front (15-25-2)		6	----	Nut
	6	----	Nut	25	4	2417 825	"D", Quarter Panel Name Letter (23-34-238)
	6	6001 472	Retainer		2	2417 826	"O"
8	2	2424 905	LETTER, Hood Front Name, "D" (15-06-16)		2	2417 828	"G"
	1	2424 906	"O"		2	2417 829	"E"
	1	2424 907	"G"		20	6023 260	Nut
	1	2424 908	"E"	26	1	2495 428-9	MOULDING PACKAGE, Quarter Panel Front (23-23-39)
	5	152 259	Nut		14	6001 611	Clip
9	2	2445 131	ORNAMENT, Fender Top (12-15-21)		2	6000 745	Clip
	2	9419 633	Screw		2	116 000	Nut
	1	2445 132-3	BASE, Fender Top Ornament	27	1	2495 282-3	MOULDING PACKAGE, Rear Window Outside Lower Corner (23-23-52)
	2	6023 201	Nut		2	6024 617	Screw
10	1	2084 997	MOULDING PACKAGE, Windshield Outside Finish Lower Center (23-23-65)		2	6001 529	Clip
	5	6000 685	Clip		2	6023 682	Screw
11	1	2299 418	MOULDING PACKAGE, Windshield Outside Finish Upper (23-23-65)	28	1	2495 420-1	MOULDING PACKAGE, Rear Door Rear (23-23-33)
	5	6000 927	Clip		2	6000 808	Clip
	1	2240 769-70	MOULDING PACKAGE, Windshield Outside Finish Side (23-23-65)		2	6022 983	Seal
	8	6000 009	Screw		2	----	Nut
13	1	2240 873-4	MOULDING PACKAGE, Front Door Window Frame Front (23-23-32)	29	1	2495 424-5	MOULDING PACKAGE, Rear Door Front (23-23-33)
	6	6023 098	Screw		8	6001 611	Clip
14	1	2240 866-7	MOULDING PACKAGE, Front Door Window Frame Upper (23-23-32)		2	6000 754	Clip
	6	6023 098	Screw		2	116 000	Nut
15	1	2093 648-9	MOULDING, Roof Drain Trough Side (23-59-61)	30	1	2495 418-9	MOULDING PACKAGE, Front Door Rear (23-23-32)
16	1	2240 868-9	MOULDING PACKAGE, Rear Door Window Frame (23-23-33)		2	6022 983	Seal
	8	6023 098	Screw		2	6000 808	Clip
17	1	2495 280-1	MOULDING PACKAGE, Rear Window Outside Upper (23-23-52)	31	1	2495 416-7	MOULDING PACKAGE, Front Door Front (23-23-32)
	14	6000 692	Clip		8	6001 611	Clip
					2	6000 745	Clip
					2	116 000	Nut

All Packages Include Attaching Parts

Part Type Code is Indicated in Parentheses

EXTERIOR VIEW - DODGE VA3(E) 4 DOOR SEDAN

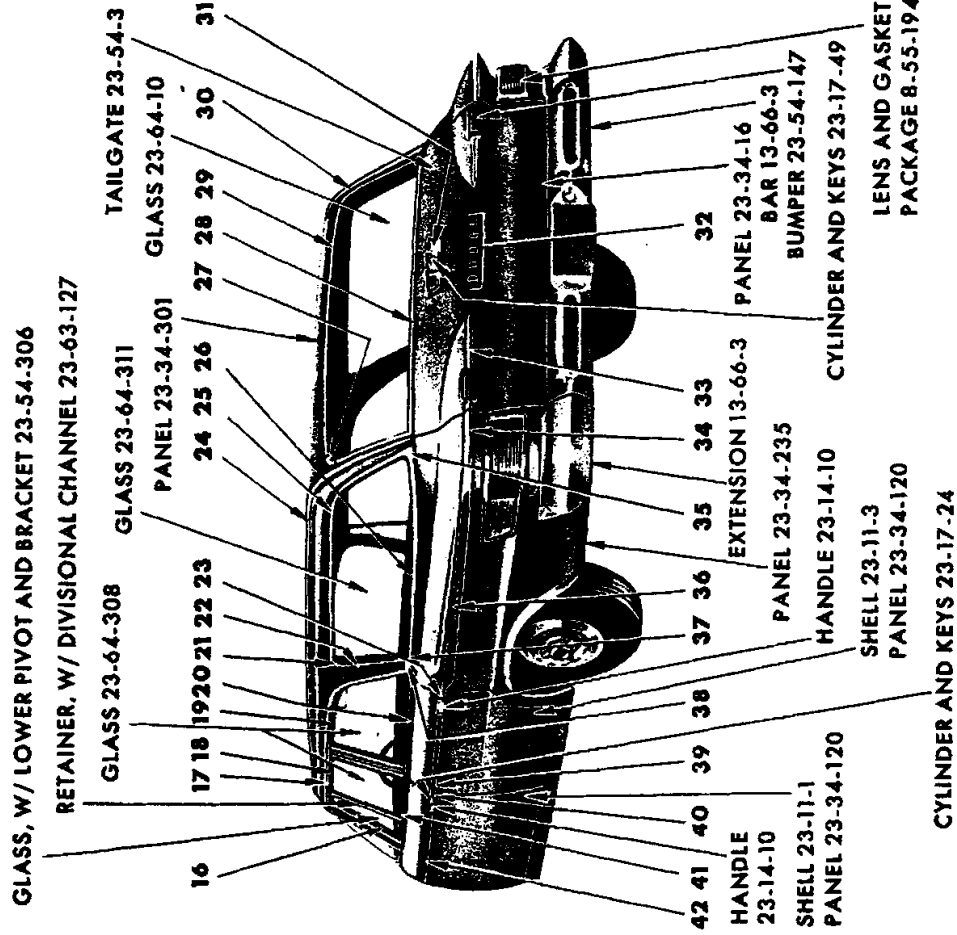

19x9890 A

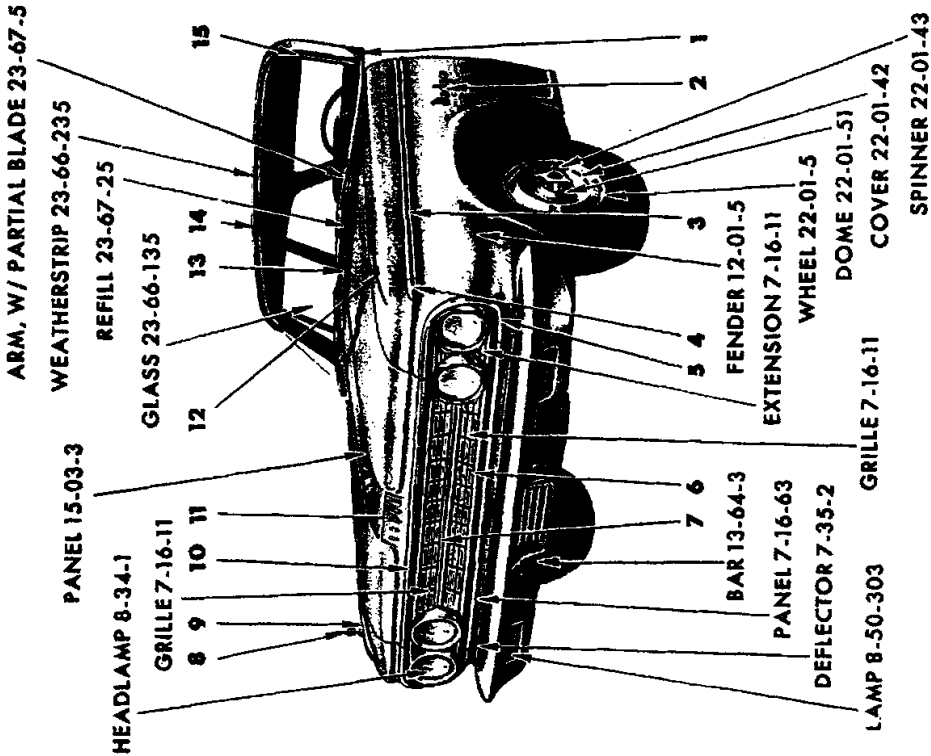

EXTERIOR VIEW - DODGE VA3(E) 4 DOOR STATION WAGON

# 1964 PASSENGER CAR PARTS CATALOG

BODY

Page 23-103

REF. NO.	QTY	PART NUMBER	DESCRIPTION	REF. NO.	QTY	PART NUMBER	DESCRIPTION
1	1	2196 272-3	MOULDING PACKAGE, Wind-shield Lower End (23-23-65)	22	1	2094 018-9	MOULDING, Quarter Window Outside Finish (23-23-73)
	2	274 411	Screw 8 6022 010 Screw	23	1	2495 420-1	MOULDING PACKAGE, Rear Door Lower Rear (23-23-33)
2	2	2445 097	NAME PLATE, Fender Side (12-15-21)		2	6000 808	Clip
	8	6000 050	Clip		2	6022 983	Seal 2 ---- Nut
3	1	2495 186-7	MOULDING PACKAGE, Fender Side (12-15-2)	24	2	2196 252	MOULDING PACKAGE, Roof Panel Outside Finish, used w/Assist Handle (23-23-42)
	4	8001 613	Retainer		2	2196 253	MOULDING PACKAGE, Roof Panel Outside Finish, used w/o Assist Handle
	10	6001 522	Retainer 10 ---- Nut	28	6006 301	Clip	
4	2	2495 186	CAP PACKAGE, Fender Side Moulding (12-15-9)	25	1	1961 212-3	MOULDING, Quarter Window Outside Finish Upper (23-23-73)
	2	----	Nut	26	1	1961 214-5	MOULDING, Quarter Window Outside Finish Lower (23-23-73)
5	1	2448 532-3	MOULDING PACKAGE, Fender Radiator Grille Opening (12-15-2)	27	1	2196 464-5	CAP PACKAGE, Roof Rear Tailgate Opening Moulding (23-23-60)
	2	6000 943	Nut		2	6006 451	Clip
	2	167 121	Screw 12 116 000 Nut	28	1	2196 460	MOULDING PACKAGE, Tailgate Outside Finish Belt (23-23-61)
6	1	2495 152	MOULDING PACKAGE, Radiator Grille Lower Panel (7-16-36)		2	6006 441	Clip 2 151 306 Screw
	8	6001 450	Retainer	29	1	2196 466	MOULDING PACKAGE, Tailgate Opening Outside Finish Roof Rear (23-23-60)
7	1	2445 081	BAR, Radiator Grille (7-16-47)		7	6006 451	Clip
	5	6025 001	Nut	30	1	2196 462-3	MOULDING PACKAGE, Rear Pillar Outside Finish (23-23-60)
8	2	2445 131	ORNAMENT, Fender Top (12-15-21)		★	6006 451	Clip
	2	9419 633	Screw	21	1	2188 389	ORNAMENT, Tailgate Outside Panel (23-54-11)
9	1	2445 132-3	BASE, Fender Top Ornament (12-15-23)		3	116 000	Nut, w/Washer
	2	6023 201	Nut	32	2	2424 905	LETTER "D", Tailgate (23-54-11)
10	1	2448 530	MOULDING PACKAGE, Hood Front (15-25-2)		1	2424 906	"O"
	6	6001 472	Retainer 6 ---- Nut		1	2424 907	"G"
11	2	2424 905	LETTER, Hood Front Name, "D" (15-06-16)		1	2424 908	"E" 10 6000 050 Clip
	1	2424 906	"O"	33	1	2275 031-2	MOULDING PACKAGE, Tailgate Outside Panel Bumper (23-23-61)
	1	2424 907	"G"		4	116 000	Nut
	1	2424 908	"E" 5 152 259 Nut	34	2	2448 507	MOULDING PACKAGE, Quarter Panel Rear (23-23-39)
12	1	2445 132-3	BASE, Fender Top Ornament (12-15-23)		2	6024 654	Screw 4 6000 820 Clip
	2	6023 201	Nut	35	1	2196 816-7	CAP PACKAGE, Quarter Window Outside Finish Lower Rear (23-23-74)
13	1	2084 997	MOULDING PACKAGE, Wind-shield Lower Center (23-23-65)		2	125 978	Screw
	5	6000 685	Clip	36	1	2495 410-1	MOULDING PACKAGE, Quarter Panel Front (23-23-39)
14	1	2299 418	MOULDING PACKAGE, Wind-shield Upper (23-23-65)		2	9416 042	Screw 12 6001 547 Clip
	5	6000 927	Clip 2 9414 754 Screw	37	2	1961 210	CAP, Quarter Window Outside Finish Front (23-23-74)
15	1	2240 769-70	MOULDING PACKAGE, Wind-shield Side (23-23-65)	38	1	2299 430-1	MOULDING PACKAGE, Quarter Panel Belt (23-23-39)
	8	6000 009	Screw		2	6024 401	Screw
16	1	2240 873-4	MOULDING PACKAGE, Front Door Window Frame Front (23-23-32)	39	1	2495 424-5	MOULDING PACKAGE, Rear Door Lower Front (23-23-33)
	6	6023 098	Screw		8	6001 611	Clip
17	1	2093 648-9	MOULDING, Roof Side Drain Trough (23-59-61)		2	6000 745	Clip 2 116 000 Nut
	1	2240 866-7	MOULDING PACKAGE, Front Door Window Frame Upper (23-23-32)	40	1	2495 418-9	MOULDING PACKAGE, Front Door Lower Rear (23-23-32)
	6	6023 098	Screw		2	6022 983	Seal 2 6000 808 Clip
18	1	2240 866-7	MOULDING PACKAGE, Front Door Window Frame Upper (23-23-32)	41	1	2298 610-1	MOULDING PACKAGE, Front Door Belt (23-23-32)
	8	6023 098	Screw		8	6001 264	Clip
19	1	2240 868-9	MOULDING PACKAGE, Rear Door Window Frame (23-23-33)	42	1	2495 416-7	MOULDING PACKAGE, Front Door Lower Front (23-23-32)
	8	6023 098	Screw		8	6001 611	Clip
20	1	2298 616-7	MOULDING PACKAGE, Rear Door Belt (23-23-33)		2	6000 745	Clip 2 116 000 Nut
	10	6001 264	Clip				
21	1	2094 018-7	CAP, Quarter Window Outside Finish Upper, w/Retainer (23-23-74)				

All Packages Include Attaching Parts  
Part Type Code is Indicated in Parentheses

EXTERIOR VIEW - DODGE VA3(E) 4 DOOR STATION WAGON



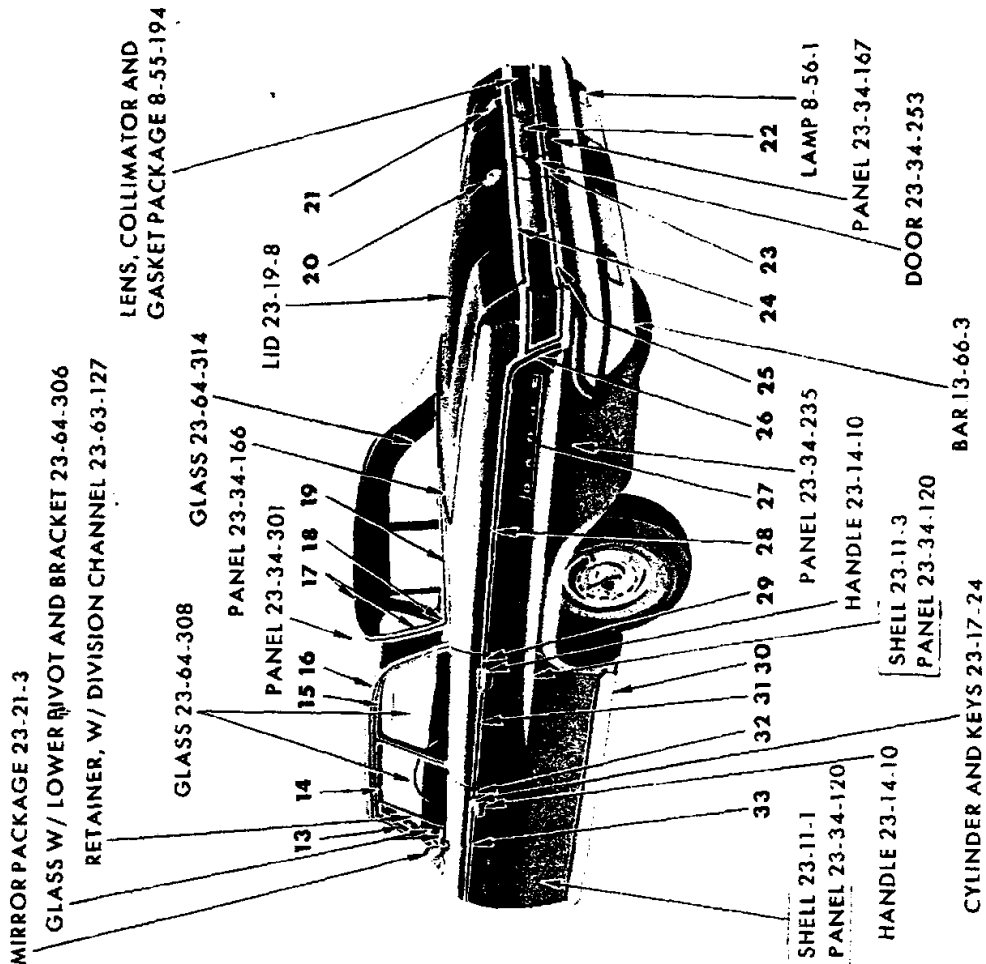

19x9850A

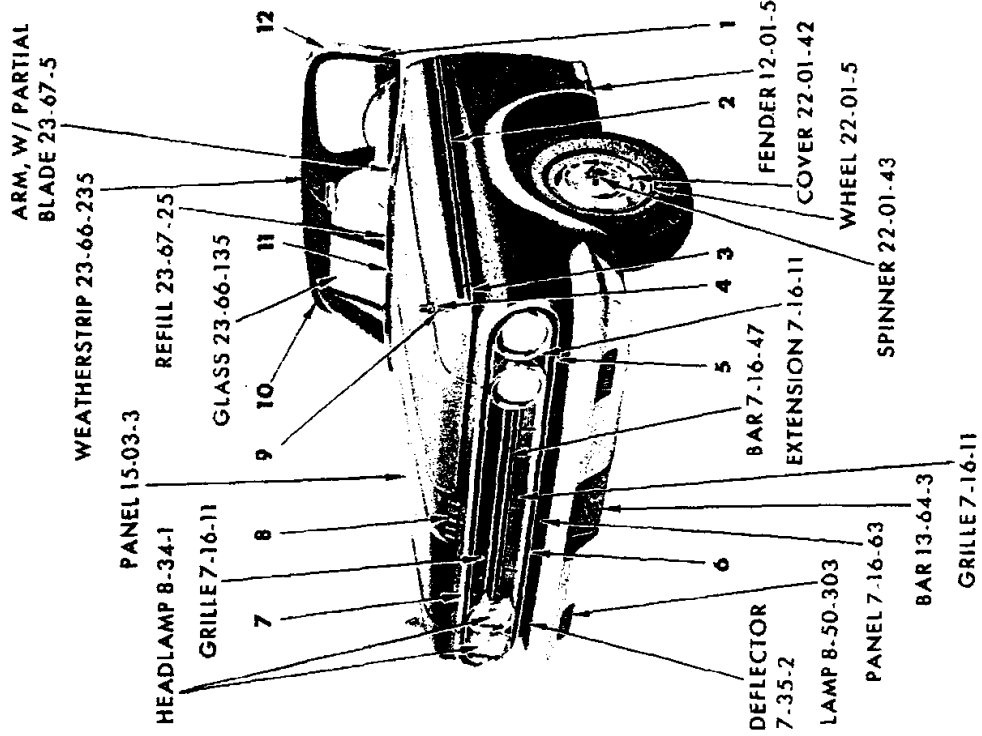

EXTERIOR VIEW - DODGE VAS(L) 4 DOOR SEDAN

REF. NO.	QTY	PART NUMBER	DESCRIPTION
1	1	2196 272-3	MOULDING PACKAGE, Windshield Outside Finish Lower End (23-23-65)
	2	274 411	Screw
	8	6022 010	Screw
2	1	2495 186-7	MOULDING PACKAGE, Fender Side (12-15-2)
	4	6001 613	Retainer
	10	6001 522	Retainer 10 ---- Nut
3	2	2495 186	CAP PACKAGE, Fender Side Moulding (12-15-9)
	2	----	Nut
4	2	2445 131	ORNAMENT, Fender Top (12-15-21)
	2	9419 633	Screw
5	1	2448 532-3	MOULDING PACKAGE, Fender Radiator Grille Opening (12-15-2)
	2	6000 943	Nut
	2	167 121	Screw 12 116 000 Nut
6	1	2495 152	MOULDING PACKAGE, Radiator Grille Lower Panel (7-16-36)
	8	6001 450	Retainer
7	1	2448 530	MOULDING PACKAGE, Hood Front (15-25-2)
	6	6001 472	Retainer
	6	----	Nut
8	2	2424 905	LETTER, Hood Front Name, "D" (15-06-16)
	1	2424 906	"O"
	1	2424 907	"G"
	1	2424 908	"E"
	5	152 259	Nut
9	1	2445 132-3	BASE, Fender Top Ornament (12-15-23)
	2	6023 201	Nut
10	1	2299 418	MOULDING PACKAGE, Windshield Outside Finish Upper (23-23-65)
	2	9414 754	Screw 5 6000 927 Clip
11	1	2084 997	MOULDING PACKAGE, Windshield Outside Finish Lower Center (23-23-65)
	5	6000 685	Clip
12	1	2240 769-70	MOULDING PACKAGE, Windshield Outside Finish Side (23-23-66)
	8	6000 009	Screw
13	1	2240 873-4	MOULDING PACKAGE, Front Door Window Frame Front (23-23-32)
	6	6023 098	Screw
14	1	2240 866-7	MOULDING PACKAGE, Front Door Window Frame Upper (23-23-32)
	6	6023 098	Screw
15	1	2240 868-9	MOULDING PACKAGE, Rear Door Window Frame (23-23-33)
	8	6023 098	Screw
16	1	2093 648-9	MOULDING, Roof Drain Trough Side (23-59-61)
17	1	2495 280-1	MOULDING PACKAGE, Rear Window Outside Upper (23-23-52)
	14	6000 692	Clip

All Packages Include Attaching Parts

REF. NO.	QTY	PART NUMBER	DESCRIPTION
18	1	2495 282-3	MOULDING PACKAGE, Rear Window Outside Lower Corner (23-23-52)
	2	6024 617	Screw
	2	6023 682	Screw 2 6001 529 Clip
19	1	2495 278	MOULDING PACKAGE, Rear Window Lower (23-23-52)
	7	6001 528	Clip
20	1	2486 344	ORNAMENT, Deck Lid Lock Cylinder (23-17-19)
21	1	2445 097	NAME PLATE, Deck Lid (23-19-114)
	3	152 259	Nut
	1	6000 050	Clip
22	1	2482 912-3	PANEL, Deck Lower Panel Finish (23-23-28)
	8	----	Washer 8 ---- Nut
23	1	2495 453	MOULDING PACKAGE, Deck Lower Panel Filler Door (23-23-23)
	2	6001 517	Retainer 2 446 618 Nut
24	1	2495 287	MOULDING PACKAGE, Deck Lid (23-23-30)
	10	6001 518	Retainer
	10	9417 621	Nut
25	1	2495 288-9	MOULDING PACKAGE, Deck Lower Panel (23-23-23)
	4	6001 517	Retainer 4 446 618 Nut
26	1	2495 422-3	MOULDING PACKAGE, Quarter Panel Rear (23-23-39)
	6	6022 052	Seal 6 ---- Nut
27	4	2417 825	NAME LETTER, Quarter Panel, "D" (23-34-238)
	2	2417 826	"O"
	2	2417 828	"G"
	2	2417 829	"E"
	20	6023 260	Nut
28	1	2495 428-9	MOULDING PACKAGE, Quarter Panel Front (23-23-39)
	14	6001 611	Clip
	2	6000 745	Clip 2 116 000 Nut
29	1	2495 420-1	MOULDING PACKAGE, Rear Door Rear (23-23-33)
	2	6000 808	Clip
	2	6022 983	Seal 2 ---- Nut
30	2	2421 588	MOULDING PACKAGE, Body Side Sill (23-23-2)
	4	9413 197	Screw
	4	6024 268	Screw 8 6000 942 Clip
31	1	2495 424-5	MOULDING PACKAGE, Rear Door Front (23-23-33)
	8	6001 541	Clip
	2	6000 745	Clip 2 116 000 Nut
32	1	2495 418-9	MOULDING PACKAGE, Front Door Rear (23-23-32)
	2	6022 983	Seal
	2	6000 808	Clip
33	1	2495 416-7	MOULDING PACKAGE, Front Door Front (23-23-32)
	8	6001 611	Clip
	2	6000 745	Clip
	2	116 000	Nut

Part Type Code is Indicated in Parentheses

EXTERIOR VIEW - DODGE VA3(L) 4 DOOR SEDAN

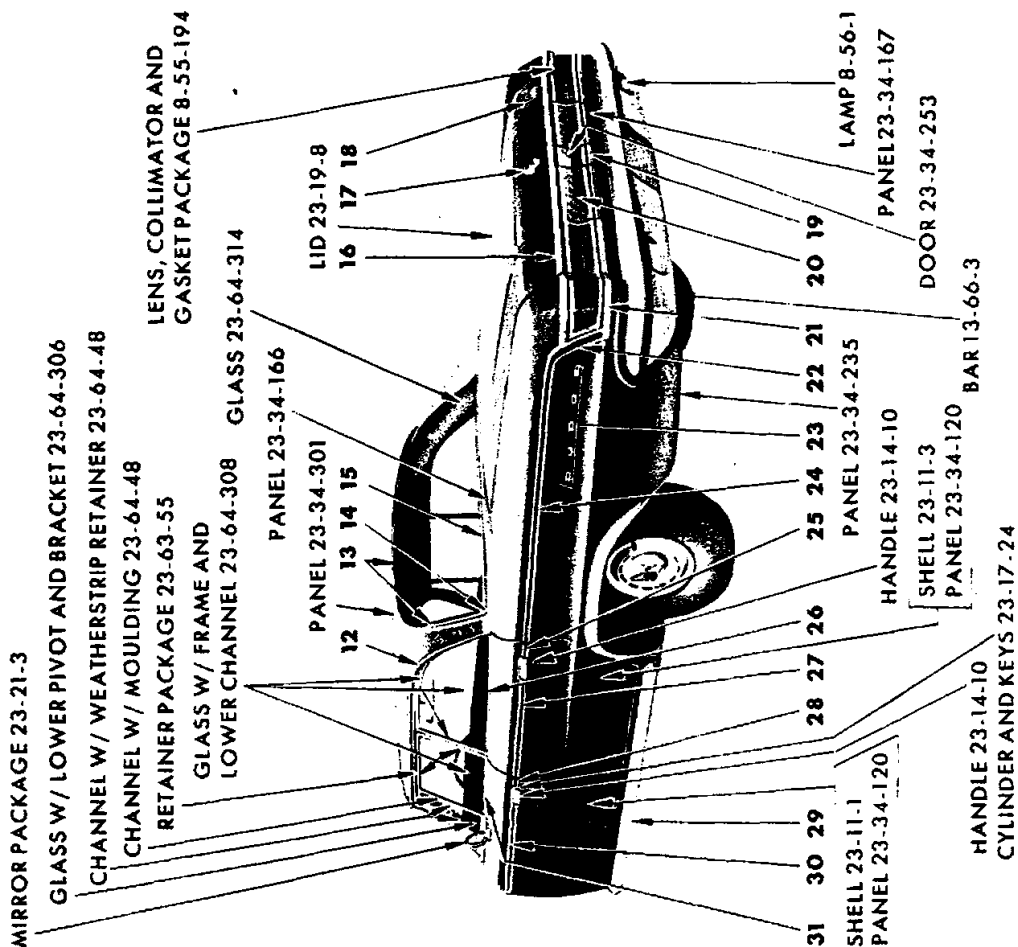

19x9849 A

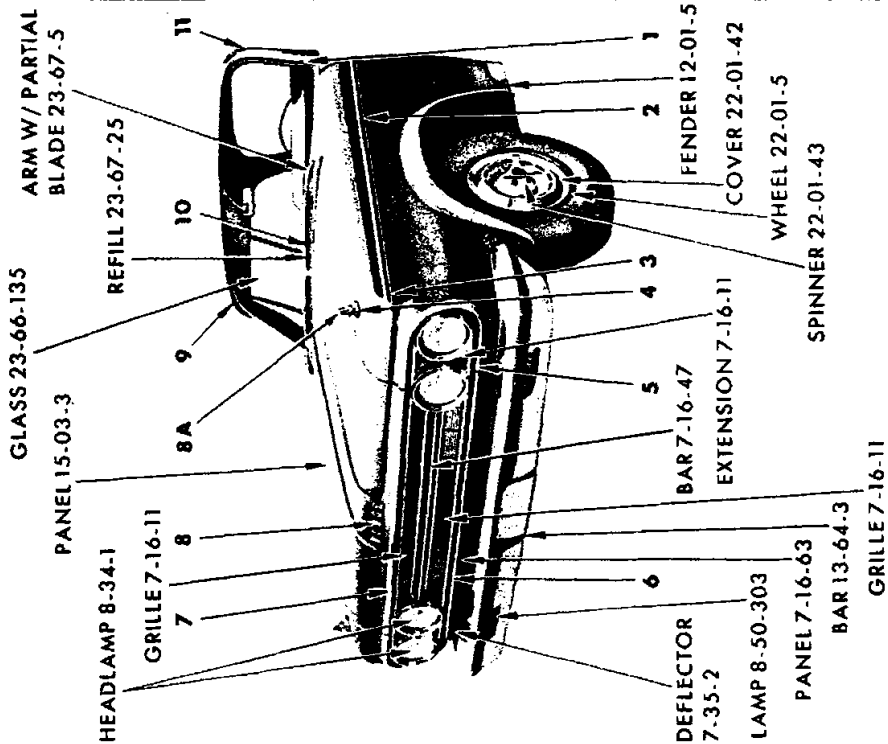

EXTERIOR VIEW - DODGE VA3(L) 4 DOOR HARDTOP

REF. NO.	QTY	PART NUMBER	DESCRIPTION
1	1	2196 272-3	MOULDING PACKAGE, Windshield Outside Finish Lower End (23-23-65)
	2	274 411	Screw
	8	6022 010	Screw
2	1	2495 186-7	MOULDING PACKAGE, Fender Side (12-15-2)
	4	6001 613	Retainer
	10	6001 522	Retainer 10 ---- Nut
3	2	2495 186	CAP PACKAGE, Fender Side Moulding (12-15-9)
	2	----	Nut
4	1	2445 132-3	BASE, Fender Top Ornament (12-15-23)
	2	9419 633	Screw
5	1	2448 532-3	MOULDING PACKAGE, Fender Radiator Grille Opening (12-15-2)
	2	6000 943	Nut
	2	187 121	Screw 12 111 600 Nut
6	1	2495 152	MOULDING PACKAGE, Radiator Grille Lower Panel (7-16-36)
	8	6001 450	Retainer
7	1	2448 530	MOULDING PACKAGE, Hood Front (15-25-2)
	6	6001 472	Retainer 6 ---- Nut
8	2	2424 905	LETTER, Hood Front "D" (15-06-16)
	1	2424 906	"O"
	1	2424 907	"G"
	1	2424 908	"E"
	5	152 259	Nut
8A	2	2445 131	ORNAMENT, Fender Top (12-15-21)
	2	9419 633	Screw
9	1	2299 418	MOULDING PACKAGE, Windshield Outside Finish Upper (23-23-65)
	5	6000 927	Clip
	2	9414 754	Screw
10	1	2084 997	MOULDING PACKAGE, Windshield Outside Finish Lower Center (23-23-65)
	5	6000 685	Clip
11	1	2240 769-70	MOULDING PACKAGE, Windshield Outside Finish Side (23-23-65)
	8	6000 009	Screw
12	1	2093 848-9	MOULDING, Roof Side Drain Trough (23-59-61)
13	1	2495 280-1	MOULDING PACKAGE, Rear Window Outside Upper (23-23-52)
	14	6000 692	Clip
14	1	2495 282-3	MOULDING PACKAGE, Rear Window Outside Lower Corner (23-23-52)
	2	6024 617	Screw
	2	6001 529	Clip
	2	6023 682	Screw
15	1	2495 278	MOULDING PACKAGE, Rear Window Lower (23-23-52)
	7	6001 528	Clip
16	1	2495 287	MOULDING PACKAGE, Deck Lid (23-23-30)
	10	6001 518	Retainer
	10	9417 621	Nut

All Packages include Attaching Parts

REF. NO.	QTY	PART NUMBER	DESCRIPTION
17	1	2486 344	ORNAMENT, Deck Lid Lock Cylinder (23-17-19)
18	1	2445 097	NAME PLATE, Deck Lid (23-19-114)
	3	152 259	Nut
	1	6000 050	Clip
19	1	2495 453	MOULDING PACKAGE, Deck Lower Panel Filler Door (23-23-23)
	2	6001 517	Retainer
	2	446 618	Nut
20	1	2482 912-3	PANEL, Deck Lower Panel Finish (23-23-28)
	8	----	Washer
	8	----	Nut
21	1	2495 288-9	MOULDING PACKAGE, Deck Lower Panel (23-23-23)
	4	6001 517	Retainer
	4	446 618	Nut
22	1	2495 422-3	MOULDING PACKAGE, Quarter Panel Rear (23-23-39)
	6	6022 052	Seal
	6	----	Nut
23	4	2417 825	NAME LETTER, Quarter Panel, "D" (23-34-238)
	2	2417 826	"O"
	2	2417 828	"G"
	2	2417 829	"E"
	20	6023 260	Nut
24	1	2495 428-9	MOULDING PACKAGE, Quarter Panel Front (23-23-39)
	14	6001 611	Clip
	2	6000 745	Clip
	2	116 000	Nut
25	1	2495 420-1	MOULDING PACKAGE, Rear Door Lower Rear (23-23-33)
	2	6000 808	Clip
	2	6022 983	Seal
	2	----	Nut
26	1	2298 616-7	MOULDING PACKAGE, Rear Door Belt (23-23-33)
	10	6001 247	Clip
27	1	2495 424-5	MOULDING PACKAGE, Rear Door Lower Front (23-23-33)
	8	6001 611	Clip
	2	6000 745	Clip
	2	116 000	Nut
28	1	2495 418-9	MOULDING PACKAGE, Front Door Lower Rear (23-23-32)
	2	6022 983	Seal
	2	6000 808	Clip
29	2	2421 588	MOULDING PACKAGE, Body Side Sill (23-23-2)
	8	6000 942	Clip
	8	9413 197	Screw
	4	6024 268	Screw
30	1	2495 416-7	MOULDING PACKAGE, Front Door Lower Front (23-23-32)
	8	6001 611	Clip
	2	6000 745	Clip
	2	116 000	Nut
31	1	2298 610-1	MOULDING PACKAGE, Front Door Belt (23-23-32)
	8	6001 264	Clip

Part Type Code is Indicated in Parentheses

EXTERIOR VIEW - DODGE VA3(L) 4 DOOR HARDTOP

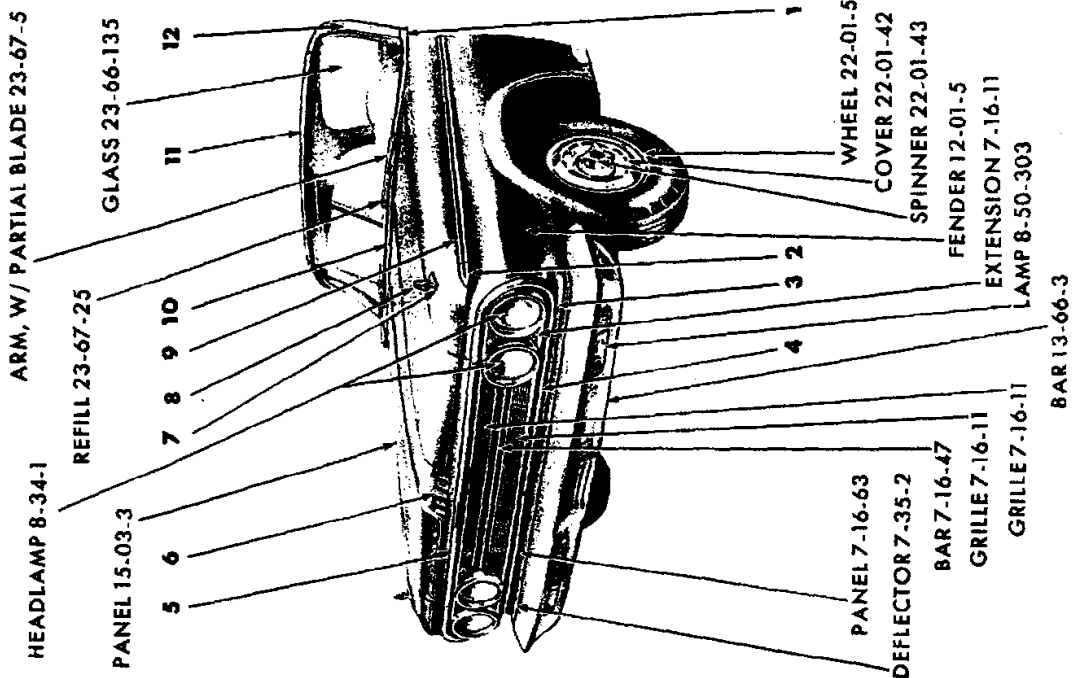
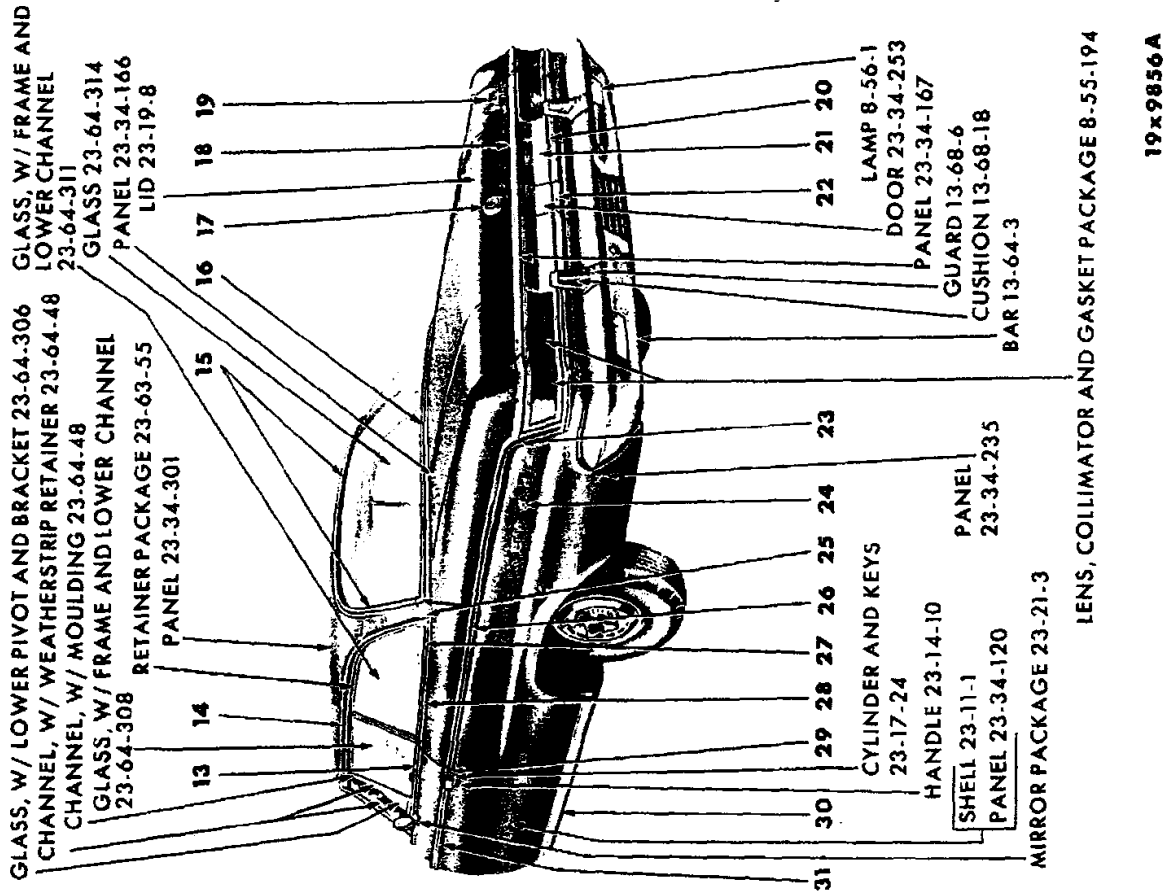

EXTERIOR VIEW - DODGE VA3(L) 2 DOOR HARDTOP

19x9856A

REF. NO.	QTY	PART NUMBER	DESCRIPTION
1	1	2196 272-3	MOULDING PACKAGE, Windshield Outside Finish Lower End (23-23-85)
	2	274 411	Screw
	8	6022 010	Screw
2	2	2495 185	CAP PACKAGE, Fender Side Moulding (12-15-9)
	2	-----	Nut
3	1	2448 532-3	MOULDING PACKAGE, Fender Radiator Grille Opening (12-15-2)
	12	116 000	Nut
	2	-----	Nut
	2	167 121	Screw
4	1	2495 152	MOULDING PACKAGE, Radiator Grille Lower Panel (7-16-36)
	8	6001 450	Retainer
5	1	2448 530	MOULDING PACKAGE, Hood Front (15-25-2)
	6	-----	Nut
	6	6001 472	Retainer
6	2	2424 906	LETTER, Hood Front Name, "D" (15-06-16)
	1	2424 906	"O"
	1	2424 907	"G"
	1	2424 908	"E"
	5	152 259	Nut
7	1	2445 132-3	BASE, Fender Top Ornament (12-15-23)
	2	9419 633	Screw
8	2	2445 131	ORNAMENT, Fender Top (12-15-21)
	2	9419 633	Screw
9	1	2495 186-7	MOULDING PACKAGE, Fender Side (12-15-2)
	4	6001 613	Retainer
	10	6001 522	Retainer
	10	-----	Nut
10	1	2084 997	MOULDING PACKAGE, Windshield Outside Finish Lower Center (23-23-85)
	5	6000 685	Clip
11	1	2299 418	MOULDING PACKAGE, Windshield Outside Finish Upper (23-23-85)
	5	6000 927	Clip
	2	9414 754	Screw
12	1	2240 769-70	MOULDING PACKAGE, Windshield Outside Finish Side (23-23-85)
	8	6000 009	Screw
13	1	2298 612-3	MOULDING PACKAGE, Door Belt (23-23-32)
	10	6001 264	Clip
14	1	2093 174	MOULDING, Roof Drain Trough Side (23-59-61)
15	1	2495 270-1	MOULDING PACKAGE, Rear Window Outside Upper (23-23-52)
	14	6000 692	Clip
16	1	2495 268	MOULDING PACKAGE, Rear Window Lower (23-23-52)
	6	6001 528	Clip
	2	6023 682	Screw

All Packages Include Attaching Parts

REF. NO.	QTY	PART NUMBER	DESCRIPTION
17	1	2486 344	ORNAMENT, Deck Lid Lock Cylinder (23-17-19)
18	1	2495 287	MOULDING PACKAGE, Deck Lid (23-23-30)
	10	6001 518	Retainer
	10	-----	Nut
19	1	2445 097	NAME PLATE, Deck Lid (23-19-114)
	3	152 259	Nut
	1	6000 050	Clip
20	1	2495 288-9	MOULDING PACKAGE, Deck Lower Panel (23-23-23)
	4	6001 517	Retainer
	4	446 618	Nut
21	1	2482 912-3	PANEL, Deck Lower Panel Finish (23-23-28)
	8	-----	Washer
	8	-----	Nut
22	1	2495 453	MOULDING PACKAGE, Deck Lower Panel Filler Door (23-23-23)
	2	6001 517	Retainer
	2	446 618	Nut
23	1	2495 422-3	MOULDING PACKAGE, Quarter Panel Lower Rear (23-23-39)
	6	6022 052	Seal
	6	-----	Nut
24	4	2417 825	"D", Quarter Panel Name Letter (23-34-238)
	2	2417 826	"O"
	2	2417 828	"G"
	2	2417 829	"E"
	20	6023 260	Nut
25	1	2495 272-3	MOULDING PACKAGE, Rear Window Lower Corner (23-23-52)
	2	6001 528	Clip
	2	6024 616	Screw
26	1	2495 426-7	MOULDING PACKAGE, Quarter Panel Lower Front (23-23-39)
	24	6001 611	Clip
	2	6000 745	Clip
	2	116 000	Nut
27	1	2421 919-20	MOULDING PACKAGE, Quarter Panel Belt Rear (23-23-39)
	2	6001 264	Clip
	2	180 075	Screw
28	1	2421 921-2	MOULDING PACKAGE, Quarter Panel Belt Front (23-23-39)
	10	6001 284	Clip
29	1	2495 412-3	MOULDING PACKAGE, Door Lower Rear (23-23-32)
	2	6022 983	Seal
	2	6000 808	Clip
30	2	2421 588	MOULDING PACKAGE, Body Side Sill (23-23-2)
	8	6000 942	Clip
	4	9413 197	Screw
	4	6024 268	Screw
31	1	2495 414-5	MOULDING PACKAGE, Door Lower Front (23-23-32)
	10	6001 611	Clip
	2	6000 745	Clip
	2	116 000	Nut

Part Type Code is Indicated in Parentheses

EXTERIOR VIEW - DODGE VA3(L) 2 DOOR HARDTOP

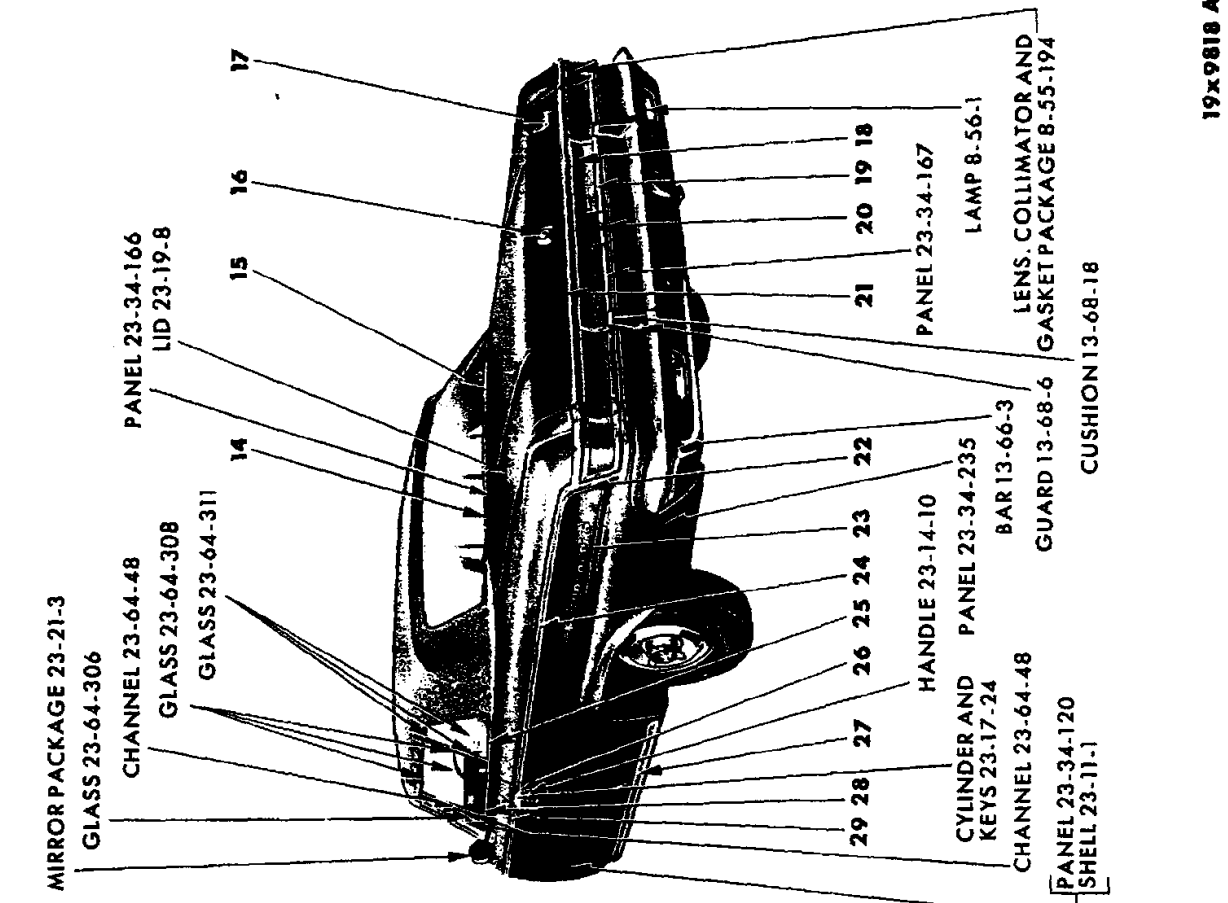

19x9818 A

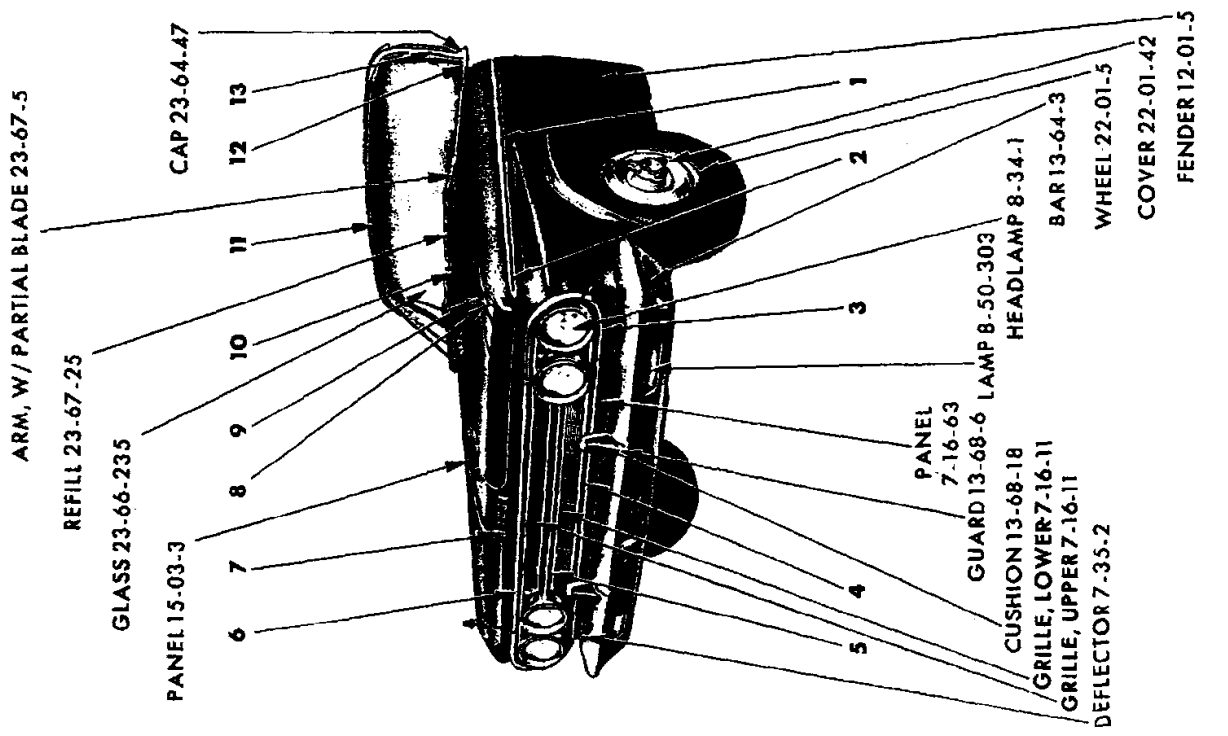

EXTERIOR VIEW - DODGE VA3(L) CONVERTIBLE COUPE

REF. NO.	QTY	PART NUMBER	DESCRIPTION	REF. NO.	QTY	PART NUMBER	DESCRIPTION
1	1	2495 186-7	MOULDING PACKAGE, Fender Side (12-15-2)	17	1	2445 097	NAME PLATE, Deck Lid (23-19-114)
	4	6001 613	Retainer		2	152 259	Nut
	10	6001 522	Retainer		1	6000 050	Clip
	10	-----	Nut	18	1	2482 912-3	PANEL, Deck Lower Panel Finish (23-23-28)
2	2	2495 187	CAP PACKAGE, Fender Side Moulding (12-15-9)		8	-----	Washer
	2	-----	Nut		8	-----	Nut
3	1	2448 532-3	MOULDING PACKAGE, Fender Radiator Grille Opening (12-15-2)	19	1	2495 288-9	MOULDING PACKAGE, Deck Lower Panel (23-23-23)
	2	6000 943	Nut		4	6001 517	Retainer
	2	167 121	Screw		4	446 618	Nut
	12	116 000	Nut	20	1	2495 453	MOULDING PACKAGE, Deck Lower Panel Filler Door (23-23-23)
4	1	2495 152	MOULDING PACKAGE, Radiator Grille Lower Panel (7-16-36)		2	6001 517	Retainer
	8	6001 450	Retainer		2	446 618	Nut
5	1	2445 081	BAR, Radiator Grille (7-16-47)	21	1	2495 287	MOULDING PACKAGE, Deck Lid (23-23-30)
	3	-----	Screw		10	6001 518	Retainer
	2	-----	Screw		10	446 618	Nut
6	1	2448 530	MOULDING PACKAGE, Hood Front (15-25-2)	22	1	2495 422-3	MOULDING PACKAGE, Quarter Panel Lower Rear Extension (23-23-39)
	6	-----	Nut		6	6022 052	Seal
	6	6001 472	Retainer		6	-----	Nut
7	2	2424 905	LETTER, Hood Front Name, "D" (15-06-16)	23	4	2417 825	LETTER, Quarter Panel, "D" (23-34-238)
	1	2424 906	"O"		2	2417 826	"O"
	1	2424 907	"G"		2	2417 828	"G"
	1	2424 908	"E"		2	2417 829	"E"
	5	152 259	Nut		20	6023 260	Nut
8	1	2445 132-3	BASE, Fender Top Ornament (12-15-23)	24	1	2495 426-7	MOULDING PACKAGE, Quarter Panel Lower Front (23-23-39)
	2	9419 633	Screw		24	6001 611	Clip
9	2	2445 131	ORNAMENT, Fender Top (12-15-21)		2	6000 745	Clip
	2	9419 633	Screw		2	116 000	Nut
10	1	2084 997	MOULDING PACKAGE, Windshield Outside Finish Lower Center (23-23-65)	25	1	2298 590-1	MOULDING PACKAGE, Quarter Panel (23-23-39)
	5	6000 685	Clip		6	6001 264	Clip
11	1	2196 119	PANEL PACKAGE, Windshield Header Outside Finish (23-23-64)	26	1	2495 412-3	MOULDING PACKAGE, Door Lower Rear (23-23-32)
	5	6024 400	Screw		2	6022 983	Seal
12	1	2196 272-3	MOULDING PACKAGE, Windshield Outside Finish Lower End (23-23-65)		2	6000 808	Clip
	2	274 411	Screw	27	2	2421 588	MOULDING PACKAGE, Body Side Sill (23-23-2)
	8	6022 010	Screw		8	6000 942	Clip
13	1	2084 998-9	MOULDING PACKAGE, Windshield Outside Finish Side, w/Extension (23-23-65)		8	9413 197	Screw
	2	6024 400	Screw		4	6024 288	Screw
14	1	2165 704-5	MOULDING, Folding Top Belt Outside (23-23-49)	28	1	2298 612-3	MOULDING PACKAGE, Door Belt (23-23-32)
	22	6000 433	Stud		10	6001 264	Clip
15	1	1963 336	COVER, Folding Top Belt Bar Outside Finish Moulding (23-23-41)	29	1	2495 414-5	MOULDING, Door Lower Front (23-23-32)
	1	6000 433	Stud		10	6001 611	Clip
16	1	2486 344	ORNAMENT, Deck Lid Lock Cylinder (23-17-19)		2	6000 745	Clip
					2	116 000	Nut

All Packages Include Attaching Parts

Part Type Code is Indicated in Parentheses

EXTERIOR VIEW - DODGE VA3(L) CONVERTIBLE COUPE



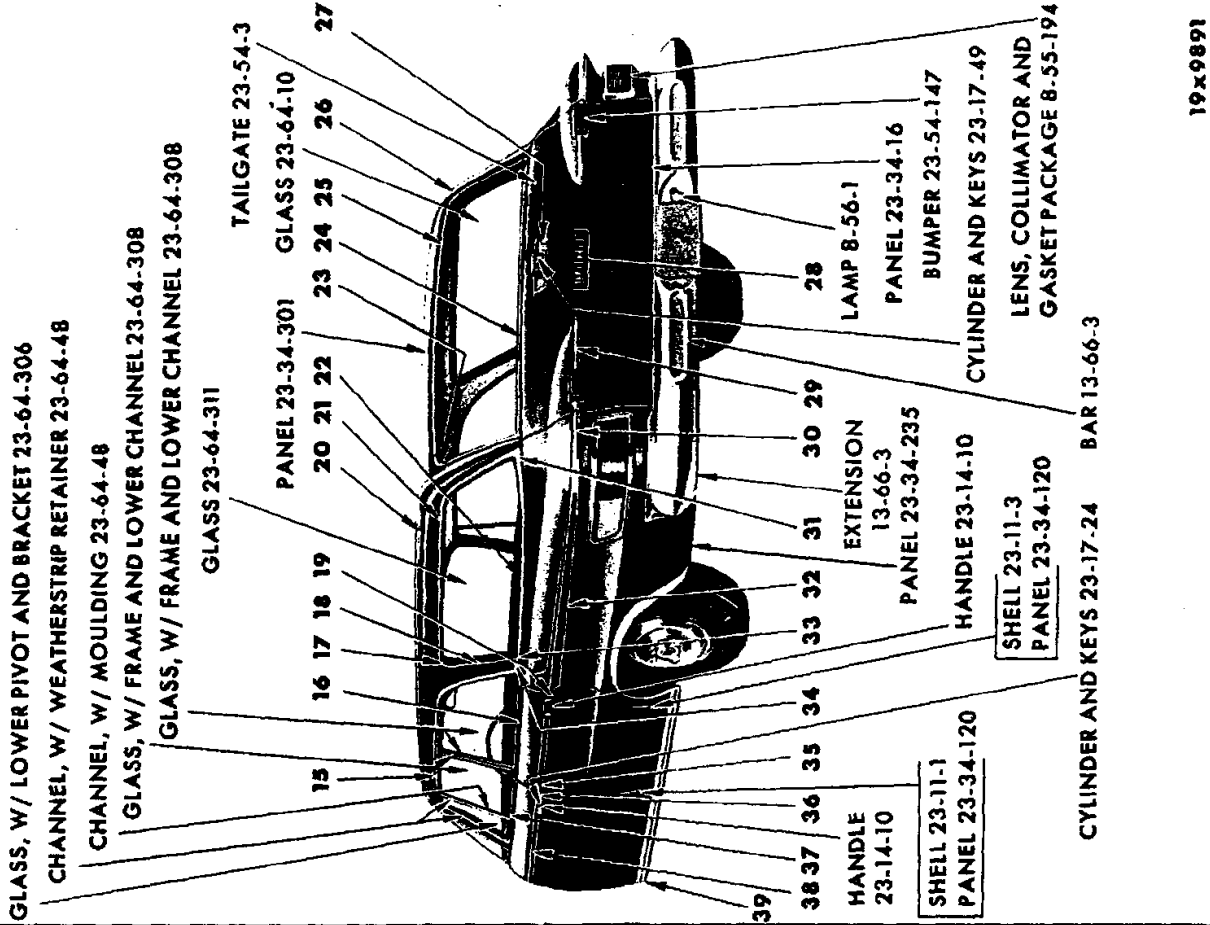

19x9891

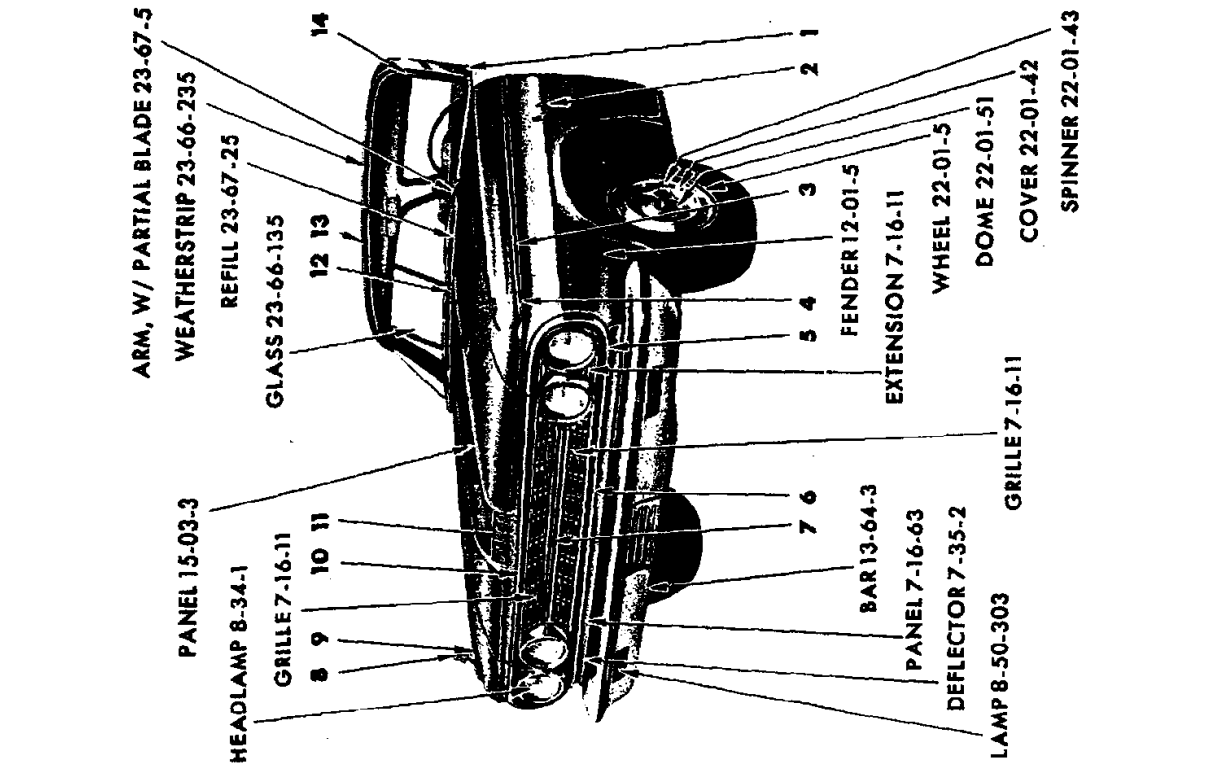

EXTERIOR VIEW - DODGE VA3(L) 4 DOOR HARDTOP STATION WAGON

REF. NO.	QTY	PART NUMBER	DESCRIPTION	REF. NO.	QTY	PART NUMBER	DESCRIPTION
1	1	2196 272-3	MOULDING PACKAGE, Windshield Lower End (23-23-65)	21	1	1961 212-3	MOULDING, Quarter Window Outside Finish Upper (23-23-73)
	8	6022 010	Screw 2 274 411 Screw	22	1	1961 214-5	MOULDING, Quarter Window Outside Finish Lower (23-23-73)
2	2	2445 097	NAME PLATE, Fender Side (12-15-21)	23	1	2196 464-5	CAP PACKAGE, Roof Rear Tailgate Opening Moulding (23-23-60)
	8	6001 254	Clip		2	6006 451	Clip
3	1	2495 186-7	MOULDING PACKAGE, Fender Side (12-15-2)	24	1	2196 460	MOULDING PACKAGE, Tailgate Outside Finish Belt (23-23-61)
	4	6001 613	Retainer		2	6006 441	Clip 2 151 306 Screw
	10	6001 522	Retainer 10 ---- --- Nut	25	1	2196 466	MOULDING PACKAGE, Tailgate Opening Outside Finish Roof Rear (23-23-60)
4	2	2495 187	CAP PACKAGE, Fender Side Moulding (12-15-2)		7	6006 451	Clip
	2	---- ---	Nut	26	1	2196 462-3	MOULDING PACKAGE, Rear Pillar Outside Finish (23-23-60)
5	1	2448 532-3	MOULDING PACKAGE, Fender Radiator Grille Opening (12-15-2)		★	6006 451	Clip
	2	6000 943	Nut	27	1	2188 389	ORNAMENT, Tailgate Outside Panel (23-54-11)
	2	167 121	Screw 12 116 000 Nut		3	116 000	Nut, w/Washer
6	1	2495 152	MOULDING PACKAGE, Radiator Grille Lower Panel (7-16-36)	28	2	2424 905	LETTER "D", Tailgate (23-54-11)
	8	6001 450	Retainer		1	2424 906	"O"
7	1	2445 081	BAR, Radiator Grille (7-16-47)		1	2424 907	"G"
	5	6025 001	Nut		1	2424 908	"E" 10 6000 050 Clip
8	2	2445 131	ORNAMENT, Fender Top (12-15-21)	29	1	2275 031-2	MOULDING PACKAGE, Tailgate Outside Panel Bumper (23-23-61)
	2	9419 633	Screw		4	116 000	Nut
9	1	2445 132-3	BASE, Fender Top Ornament (12-15-23)	30	2	2448 507	MOULDING PACKAGE, Quarter Panel Rear (23-23-39)
	2	6023 201	Nut		2	6024 654	Screw 4 6000 820 Clip
10	1	2448 530	MOULDING PACKAGE, Hood Front (15-25-2)	31	1	2196 816-7	CAP PACKAGE, Quarter Window Outside Finish Lower Rear (23-23-74)
	6	6001 472	Retainer 6 ---- --- Nut		2	125 978	Screw
11	2	2424 905	LETTER, Hood Front Name, "D" (15-06-16)	32	1	2495 410-1	MOULDING PACKAGE, Quarter Panel Front (23-23-39)
	1	2424 906	"O"		2	9416 042	Screw 12 6001 547 Clip
	1	2424 907	"G"	33	2	1961 210	CAP, Quarter Window Outside Finish Front (23-23-74)
	1	2424 908	"E" 5 152 259 Nut	34	1	2299 430-1	MOULDING PACKAGE, Quarter Panel Belt (23-23-39)
12	1	2084 997	MOULDING PACKAGE, Windshield Lower Center (23-23-65)		2	6024 401	Screw
	5	6000 885	Clip	35	1	2495 424-5	MOULDING PACKAGE, Rear Door Lower Front (23-23-33)
13	1	2299 418	MOULDING PACKAGE, Windshield Upper (23-23-65)		8	6001 611	Clip
	2	9414 754	Screw 5 6000 927 Clip		2	6000 745	Clip 2 116 000 Nut
14	1	2240 769-70	MOULDING PACKAGE, Windshield Side (23-23-65)	36	1	2495 418-9	MOULDING PACKAGE, Front Door Lower Rear (23-23-32)
	8	6000 009	Screw		2	6022 983	Seal 2 6000 808 Clip
15	1	2093 648-9	MOULDING, Roof Side Drain Trough (23-59-61)	37	1	2298 610-1	MOULDING PACKAGE, Front Door Belt (23-23-32)
16	1	2298 616-7	MOULDING PACKAGE, Rear Door Belt (23-23-33)		8	6001 264	Clip
	10	6001 264	Clip	38	1	2495 416-7	MOULDING PACKAGE, Front Door Lower Front (23-23-32)
17	1	2094 016-7	CAP, Quarter Window Outside Finish Upper, w/Retainer (23-23-74)		8	6001 611	Clip
18	1	2094 018-9	MOULDING, Quarter Window Outside Finish Front (23-23-73)		2	6000 745	Clip 2 116 000 Nut
19	1	2495 420-1	MOULDING PACKAGE, Rear Door Lower Rear (23-23-33)	39	2	2421 588	MOULDING PACKAGE, Side Sill (23-23-2)
	2	6000 808	Clip		8	6000 942	Clip 4 9413 197 Screw
	2	6022 983	Seal 2 ---- --- Nut		4	6024 268	Screw
20	2	2196 252	MOULDING PACKAGE, Roof Panel Outside Finish used w/Assist Handle (23-23-42)				
	2	2196 253	MOULDING PACKAGE, Roof Panel Outside Finish, used w/o Assist Handle				
	28	6006 301	Clip				

All Packages include Attaching Parts

EXTERIOR VIEW - DODGE VA3(L) 4 DOOR HARDTOP STATION WAGON

Part Type Code is Indicated in Parentheses