

EXTERIOR VIEW - CHRYSLER VC1(L) 4 DOOR SEDAN

19x9923

REF. NO.	QTY	PART NUMBER	DESCRIPTION
1	1	2448 556-7	MOULDING PACKAGE, Fender Wheel Opening to Sill (12-15-2)
	2	-----	Clip
	2	6008 438	Nut
	2	6023 247	Screw
2	1	2276 470-1	MOULDING PACKAGE, Fender Wheel Opening (12-15-2)
	16	6023 247	Screw
3	1	2495 706-7	MOULDING PACKAGE, Fender Side (12-15-2)
	10	6001 605	Retainer
	12	6001 462	Retainer
	4	6001 557	Clip
	12	6024 679	Nut
4	2	2276 474	NAME PLATE, Fender Side (12-15-21)
	8	152 259	Nut
5	1	2495 180	MOULDING PACKAGE, Hood Front (15-25-2)
	6	9411 618	Nut
6	1	2495 726	MOULDING PACKAGE, Radiator Grille Opening Frame (7-16-36)
	9	6001 070	Clip
	9	6023 284	Nut
	9	9415 921	Screw
7	1	2276 410	FRAME, Radiator Grille Opening (7-16-36)
8	1	2495 730-1	MOULDING PACKAGE, Radiator Grille Opening Corner (7-16-36)
	4	6024 689	Nut
9	3	2417 747	MEDALLION, Radiator Grille (7-17-1)
	6	6025 434	Nut
10	1	2495 181	MOULDING PACKAGE, Hood Top (15-25-2)
	7	6023 097	Nut
11	1	2084 997	MOULDING PACKAGE, Windshield Outside Finish Lower Center (23-23-65)
	5	6000 685	Clip
12	1	2495 694	MOULDING PACKAGE, Windshield Outside Finish Upper Center (23-23-65)
	2	6023 277	Screw
13	1	2495 696-7	MOULDING, Windshield Outside Finish Lower End (23-23-65)
	2	274 411	Screw
14	1	2216 870-1	MOULDING, Windshield Outside Finish Side (23-23-65)
	8	6023 247	Screw
15	1	2448 552-3	MOULDING PACKAGE, Front Door Belt (23-23-32)
	8	6001 497	Retainer
	2	6001 087	Retainer
	2	9417 621	Nut
16	1	2243 734-5	MOULDING, Roof Side Drain Trough Front (23-59-61)
17	1	2448 490-1	MOULDING PACKAGE, Rear Door Belt Front (23-23-33)
	6	6001 497	Retainer

REF. NO.	QTY	PART NUMBER	DESCRIPTION
18	1	2243 738-9	CAP, Roof Side Drain Trough Moulding Joint (23-59-57)
19	1	2424 498-9	MOULDING w/Cap, Roof Side Drain Trough Rear (23-59-61)
	6	6024 271	Screw w/Sealer
20	1	2424 292-3	MOULDING, Rear Door Belt Rear (23-23-33)
	2	6024 638	Screw
	6	-----	Washer
	2	6000 960	Clip
	4	9415 312	Nut
21	1	2423 092-3	MOULDING, Rear Window Outside Side and Lower (23-23-52)
	12	6001 084	Retainer and Screw
22	1	2423 091	MOULDING, Rear Window Outside Upper (23-23-52)
	7	6001 084	Retainer and Screw
23	1	2423 504	"C", Deck Lid Letter (23-19-114)
	1	2423 505	"H"
	2	2423 506	"R"
	1	2423 507	"Y"
	1	2423 508	"S"
	1	2423 509	"L"
	1	2423 510	"E"
	8	152 259	Nut
24	3	2480 703	MEDALLION and STUDS, Deck Opening Lower Panel (23-34-184)
	6	9418 877	Nut
	6	6022 077	Seal
25	1	2421 448	MOULDING PACKAGE, Deck Lower Panel Filler Door (23-23-23)
	2	6000 709	Clip 2 6023 265 Nut
26	1	2448 428-9	MOULDING PACKAGE, Quarter Panel Lower Rear (23-23-39)
	10	6001 099	Retainer 4 ----- Nut
	10	6024 679	Nut 2 188 973 Screw
27	1	2525 560-1	MOULDING PACKAGE, Quarter Panel Upper (23-23-39)
	14	6024 656	Washer
	14	9411 618	Nut
28	1	2495 490-1	MOULDING PACKAGE, Quarter Panel Lower (23-23-39)
	2	6024 271	Screw
	4	6001 506	Clip 8 6001 548 Clip
	8	6024 679	Nut 2 6001 507 Clip
29	1	2495 484-5	MOULDING PACKAGE, Rear Door Lower (23-23-33)
	10	6001 505	Retainer 2 ----- Clip
	2	9417 621	Nut
30	2	2495 449	MOULDING PACKAGE, Front Door Lower (23-23-32)
	4	6001 544	Clip 4 9417 621 Nut
	8	6001 605	Retainer
31	1	2421 571-2	MOULDING PACKAGE, Body Side Sill (23-23-2)
	14	6001 100	Retainer
	2	2422 576	Clip 4 ----- Washer
	1	2422 574-5	Clip 4 ----- Nut

All Packages Include Attaching Parts

Part Type Code is Indicated in Parentheses

EXTERIOR VIEW - CHRYSLER VC1(L) 4 DOOR SEDAN

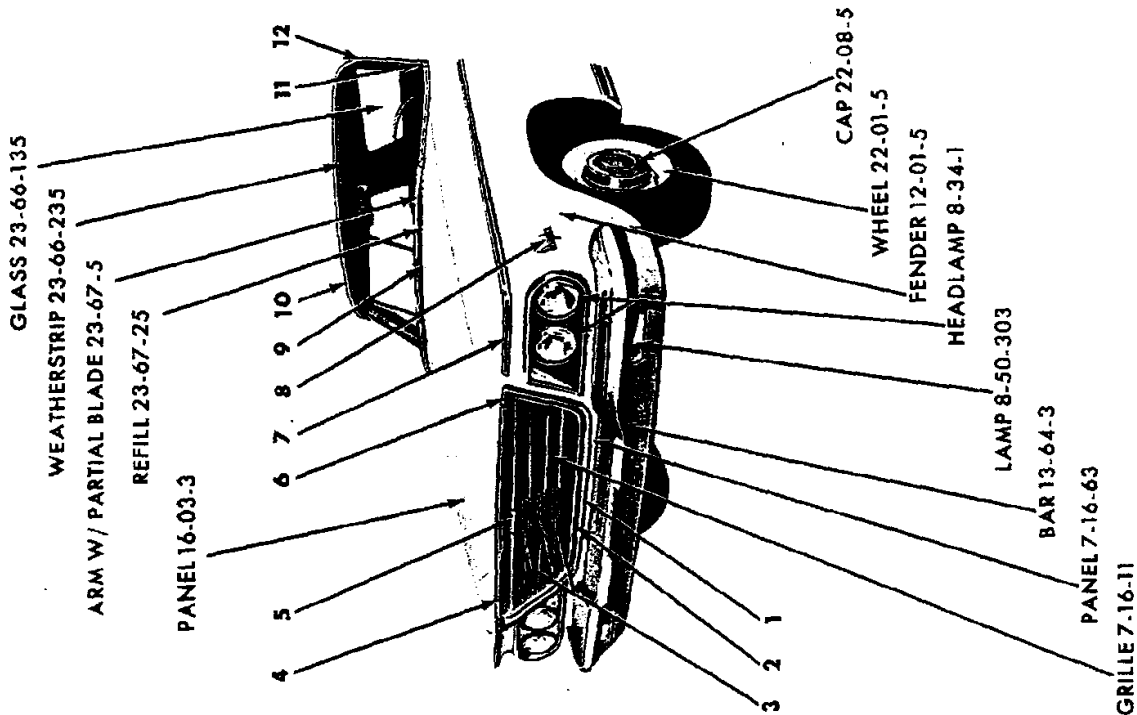
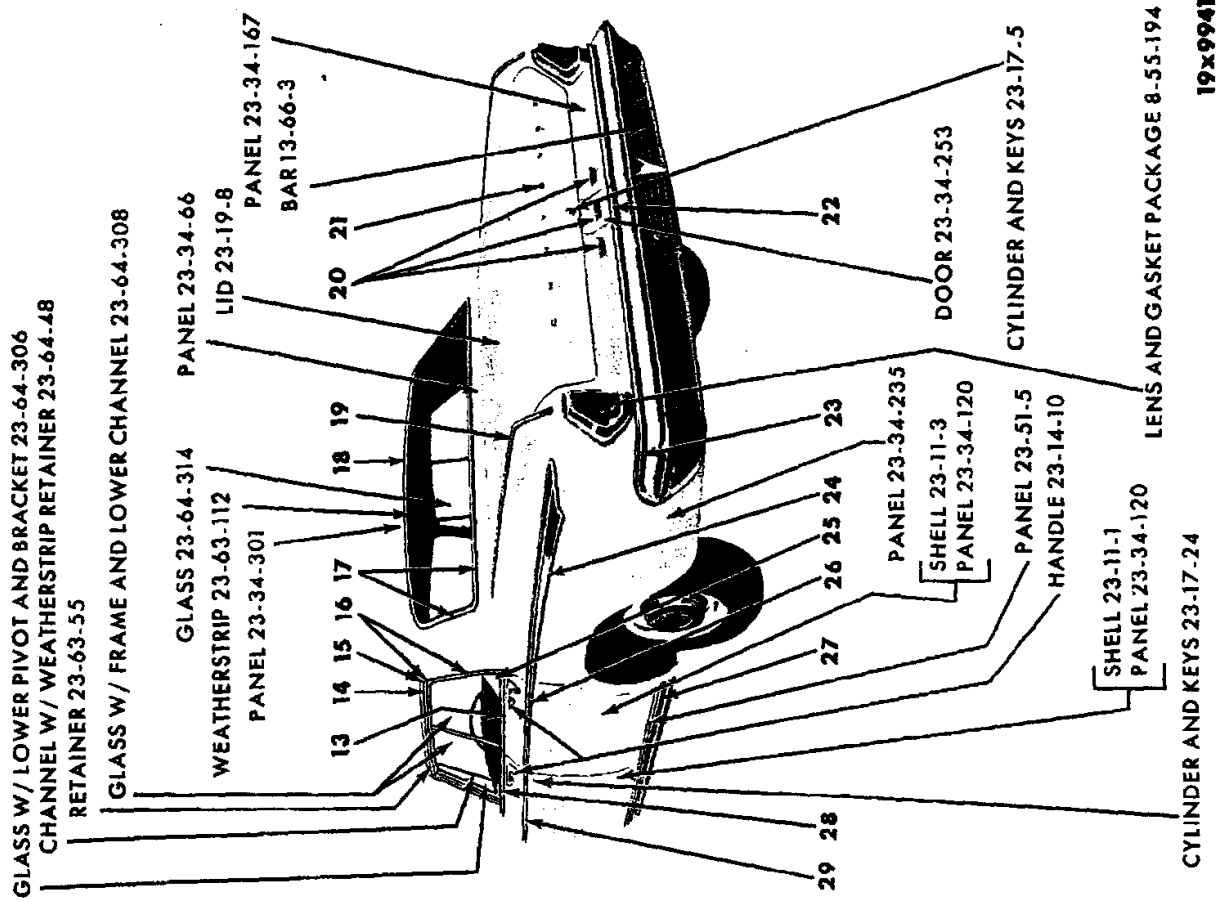

EXTERIOR VIEW - CHRYSLER VCI(L) 4 DOOR HARDTOP

1964 PASSENGER CAR PARTS CATALOG

BODY

Page 23-117

REF. NO.	QTY	PART NUMBER	DESCRIPTION
1	1	2495 726	MOULDING PACKAGE; Radiator Grille Opening Frame (7-16-36)
	9	6001 070	Clip
	9	6023 284	Nut 9 9415 921 Screw
2	1	2276 410	FRAME, Radiator Grille Opening (7-16-36)
3	3	2417 747	MEDALLION, Radiator Grille (7-17-1)
	6	6025 434	Nut
4	1	2495 180	MOULDING PACKAGE, Hood Front (15-25-2)
	6	9411 618	Nut
5	1	2417 874	DOOR, Radiator Grille Hood Lock Access (7-16-65)
6	1	2495 730-1	MOULDING PACKAGE, Radiator Grille Opening Corner (7-16-36)
	4	6024 889	Nut
7	1	2495 706-7	MOULDING PACKAGE, Fender Side (12-15-2)
	10	6001 605	Retainer 4 6001 557 Clip
	12	6001 462	Retainer 12 6024 679 Nut
8	2	2276 474	NAME PLATE, Fender Side (12-15-21)
	8	152 259	Nut
9	1	2084 997	MOULDING PACKAGE, Windshield Outside Finish Lower Center (23-23-65)
	5	6000 685	Clip
10	1	2495 694	MOULDING PACKAGE, Windshield Outside Finish Upper Center (23-23-65)
	5	6000 927	Clip 2 6023 277 Screw
11	1	2495 696-7	MOULDING, Windshield Outside Finish Lower End (23-23-65)
	2	274 411	Screw
12	1	2216 870-1	MOULDING, Windshield Outside Finish Side (23-23-65)
	8	6023 247	Screw
13	1	2448 490-1	MOULDING PACKAGE, Rear Door Belt Front (23-23-33)
	6	6001 497	Retainer
14	1	2243 734-5	MOULDING, Roof Side Drain Trough Front (23-59-61)
15	1	2243 738-9	CAP, Roof Side Drain Trough Moulding Joint (23-59-57)
16	1	2424 498-9	MOULDING w/JOINT CAP, Roof Side Train Trough Rear (23-59-61)
	6	6024 271	Screw w/Sealer
17	1	2423 092-3	MOULDING, Rear Window Outside Side and Lower (23-23-52)
	12	6001 084	Retainer and Screw

REF. NO.	QTY	PART NUMBER	DESCRIPTION
18	1	2423 091	MOULDING, Rear Window Outside Upper (23-23-52)
	7	6001 084	Retainer and Screw
19	1	2525 560-1	MOULDING PACKAGE, Quarter Panel Peak (23-23-39)
	14	6024 656	Washer 14 9411 618 Nut
20	3	2480 703	MEDALLION and STUDS, Deck Opening Lower Panel (23-34-184)
	6	9418 877	Nut 6 6022 077 Seal
21	1	2423 504	"C", Deck Lid Letter (23-19-114)
	1	2423 505	"H"
	2	2423 506	"R"
	1	2423 507	"Y"
	1	2423 508	"S"
	1	2423 509	"L"
	1	2423 510	"E"
	10	152 259	Nut
22	1	2421 448	MOULDING PACKAGE, Deck Lower Panel Filler Door (23-23-23)
	2	6000 709	Clip 2 6024 679 Nut
23	1	2448 428-9	MOULDING PACKAGE, Quarter Panel Lower Rear (23-23-39)
	10	6001 099	Retainer
	2	6024 679	Nut
	4	----	Nut 2 188 973 Screw
24	1	2495 490-1	MOULDING PACKAGE, Quarter Panel Upper (23-23-39)
	2	6024 271	Screw
	4	6001 506	Clip 8 6024 679 Nut
	8	6001 548	Clip 2 6001 570 Clip
25	1	2424 292-3	MOULDING, Rear Door Belt Rear (23-23-33)
	2	6024 638	Screw 2 6000 960 Clip
	6	----	Washer 4 9415 312 Nut
26	1	2495 484-5	MOULDING PACKAGE, Rear Door Lower (23-23-33)
	10	6001 505	Retainer
	2	----	Clip 2 9417 621 Nut
27	1	2421 571-2	MOULDING PACKAGE, Body Side Sill (23-23-2)
	14	6001 100	Retainer
	4	----	Washer 1 2422 574-5 Clip
	2	2422 576	Clip 4 ---- Nut
28	1	2448 552-3	MOULDING PACKAGE, Front Door Belt (23-23-32)
	8	6001 497	Retainer
	2	6001 087	Retainer 2 9417 621 Nut
29	2	2495 449	MOULDING PACKAGE, Front Door Lower (23-23-32)
	8	6001 605	Retainer
	4	6001 544	Clip 4 9417 621 Nut

All Packages Include Attaching Parts

Part Type Code Is Indicated in Parentheses

EXTERIOR VIEW - CHRYSLER VC1(L) 4 DOOR HARDTOP

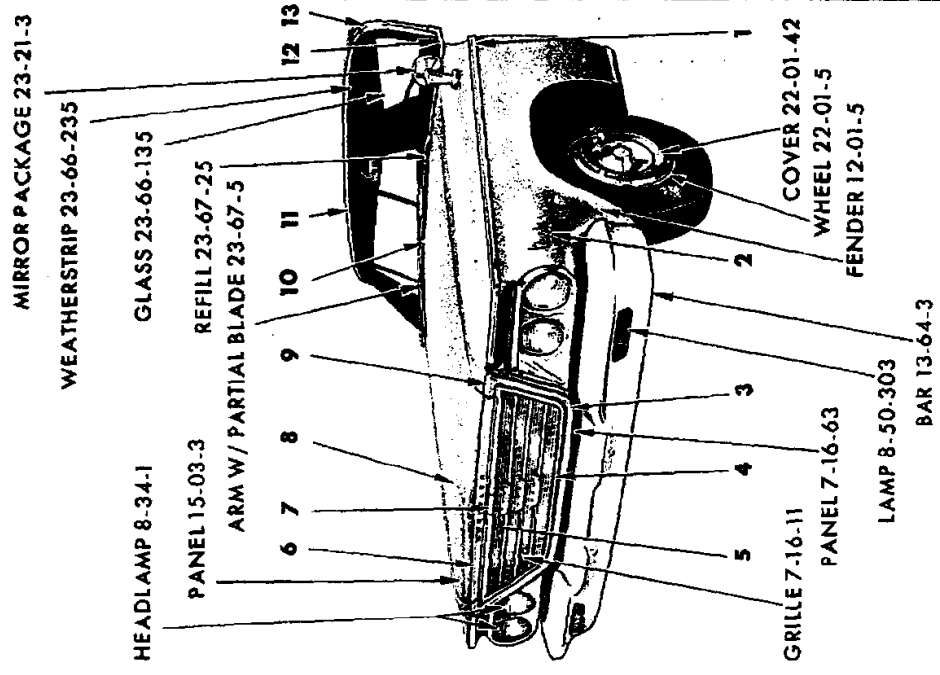
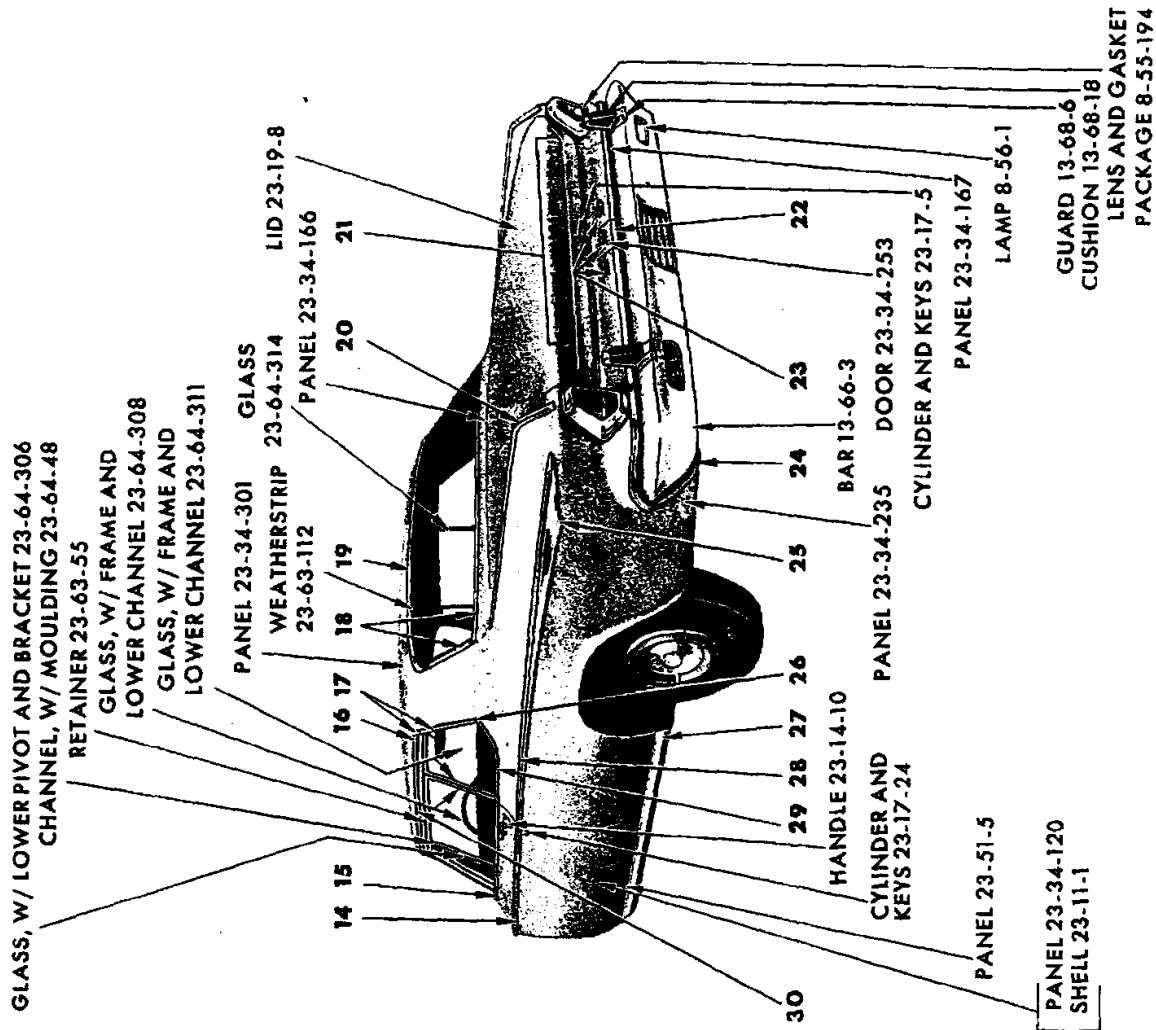

EXTERIOR VIEW - CHRYSLER VC1(L) 2 DOOR HARDTOP

REF. NO.	QTY	PART NUMBER	DESCRIPTION	REF. NO.	QTY	PART NUMBER	DESCRIPTION
1	1	2495 706-7	MOULDING PACKAGE, Fender Side (12-15-2)	16	1	2243 738-9	CAP, Roof Side Drain Trough Moulding Joint (23-59-57)
	10	6001 605	Retainer	17	1	2482 782-3	MOULDING, w/Joint Cap, Roof Side Drain Trough (23-59-61)
	12	6001 462	Retainer		6	6024 271	Screw, w/Sealer
	4	6001 557	Clip	18	1	2423 092-3	MOULDING, Rear Window Outside Side and Lower (23-23-52)
	12	6024 679	Nut	19	1	2423 091	MOULDING, Rear Window Outside Upper (23-23-52)
2	2	2276 474	NAME PLATE, Fender Side (12-15-21)		7	6001 084	Retainer and Screw
	8	152 259	Nut	20	1	2525 560-1	MOULDING PACKAGE, Quarter Panel Peak (23-23-39)
3	1	2495 726	MOULDING PACKAGE, Radiator Grille Opening Frame (7-16-36)		14	6024 656	Washer 14 9411 618 Nut
	9	6001 070	Clip 9 6023 284 Nut	21	1	2423 504	"C", Deck Lid Letter (23-19-114)
	9	9415 921	Screw		1	2423 505	"H"
4	1	2276 410	FRAME, Radiator Grille Opening (7-16-36)		2	2423 506	"R"
5	3	2417 747	MEDALLION, Radiator Grille (7-17-1)		1	2423 507	"Y"
	6	6025 434	Nut		1	2423 508	"S"
6	1	2495 180	MOULDING PACKAGE, Hood Front (15-25-2)		1	2423 509	"L"
	6	9411 618	Nut		1	2423 510	"E"
7	1	2417 874	DOOR, Radiator Grille Hood Lock Access (7-16-65)	22	1	2421 448	MOULDING PACKAGE, Deck Lower Panel License Depression (23-23-23)
8	1	2495 181	MOULDING PACKAGE, Hood Top (15-25-2)		2	6000 709	Clip 2 6024 679 Nut
	7	6023 097	Nut	23	3	2480 703	MEDALLION and STUDS, Deck Opening Lower Panel (23-34-184)
9	1	2495 730-1	MOULDING PACKAGE, Radiator Grille Opening Corner (7-16-36)		6	9418 877	Nut 6 6022 077 Seal
	4	6024 689	Nut	24	1	2448 428-9	MOULDING PACKAGE, Quarter Panel Lower Rear (23-23-39)
10	1	2084 997	MOULDING PACKAGE, Windshield Outside Finish Lower Center (23-23-65)		10	6001 099	Retainer
	5	6000 685	Clip		10	6024 679	Nut
11	1	2495 694	MOULDING PACKAGE, Windshield Outside Finish Upper Center (23-23-65)		4	----	Nut 2 188 973 Screw
	5	6000 927	Clip 2 6023 277 Screw	25	1	2495 496-7	MOULDING PACKAGE, Quarter Panel Upper Rear (23-23-39)
12	1	2495 696-7	MOULDING, Windshield Outside Finish Lower End (23-23-65)		2	6024 271	Screw 4 6001 506 Clip
	2	274 411	Screw		8	6001 548	Clip 8 6024 679 Nut
13	1	2216 870-1	MOULDING, Windshield Outside Finish Side (23-23-65)		2	6001 507	Clip
	8	6023 247	Screw	26	1	2528 992-3	MOULDING, Roof Side Drain Trough Rear Lower (23-59-61)
14	2	2495 450	MOULDING PACKAGE, Door Lower (23-23-32)	27	1	2421 571-2	MOULDING PACKAGE, Body Side Sill (23-23-2)
	2	6001 544	Clip		14	6001 100	Retainer
	2	9417 621	Nut		1	2422 574-5	Clip 2 2422 576 Clip
	12	6001 545	Retainer		4	----	Nut 4 ---- Washer
15	1	2448 550-1	MOULDING PACKAGE, Door Belt (23-23-32)	28	1	2495 700-1	MOULDING PACKAGE, Quarter Panel Upper Front (23-23-39)
	10	6001 497	Retainer		8	6001 505	Clip
	2	6001 087	Retainer		2	6024 271	Screw 2 6024 679 Nut
	2	9417 621	Nut	29	1	2421 554-5	MOULDING PACKAGE, Quarter Panel Belt (23-23-39)
					8	6001 497	Retainer
				30	1	2243 734-5	MOULDING, Roof Side Drain Trough Front (23-59-61)

All Packages Include Attaching Parts

Part Type Code is Indicated in Parentheses

EXTERIOR VIEW - CHRYSLER VC1(L) 2 DOOR HARDTOP

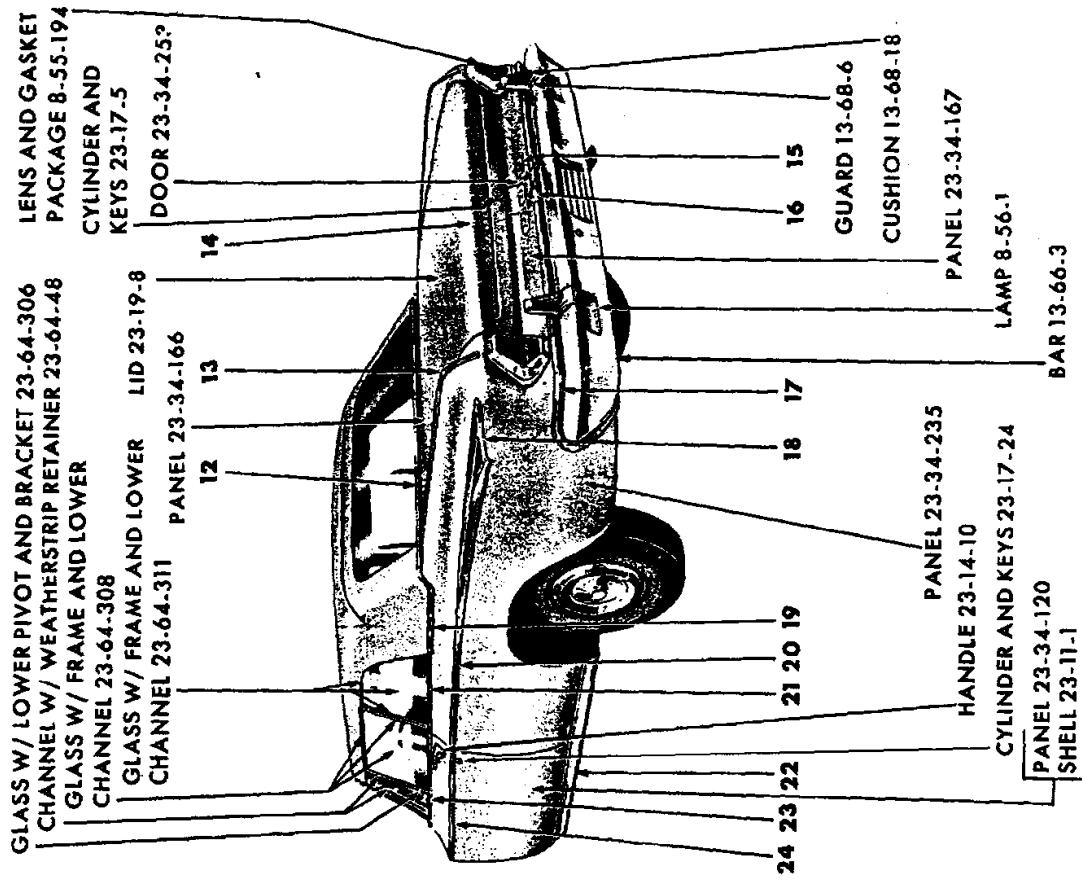

19K9932

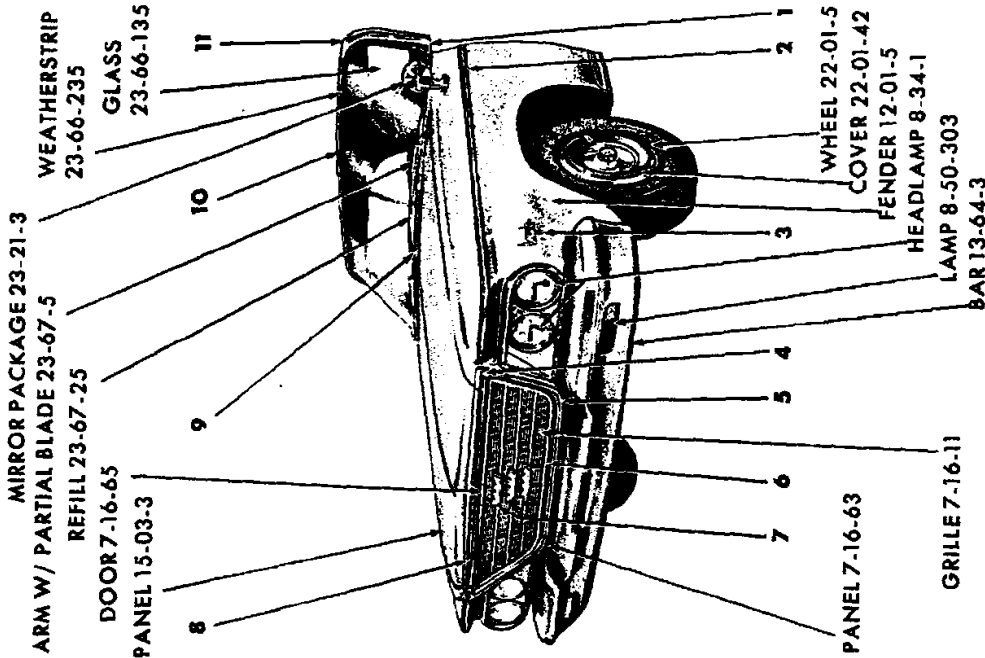

EXTERIOR VIEW - CHRYSLER VCI(L) CONVERTIBLE COUPE

1964 PASSENGER CAR PARTS CATALOG

BODY

Page 23-121

REF. NO.	QTY	PART NUMBER	DESCRIPTION	REF. NO.	QTY	PART NUMBER	DESCRIPTION
1	1	2495 696-7	MOULDING, Windshield Outside Finish Lower End (23-23-65)	15	3	2480 703	MEDALLION and STUDS, Deck Opening Lower Panel (23-34-184)
	2	274 211	Screw		6	9418 877	Nut 6 6022 077 Seal
2	1	2495 706-7	MOULDING PACKAGE, Fender Side (12-15-2)	16	1	2421 448	MOULDING PACKAGE, Deck Lower Panel Filler Door (23-23-23)
	10	6001 605	Retainer 4 6001 557 Clip		2	6000 709	Clip 2 6024 679 Nut
	12	6001 462	Retainer 12 6024 679 Nut	17	1	2448 428-9	MOULDING PACKAGE, Quarter Panel Lower Rear (23-23-39)
3	2	2276 474	NAME PLATE, Fender Side (12-15-21)		10	6001 099	Retainer 4 ---- --- Nut
	8	152 259	Nut		10	6024 679	Nut 2 188 973 Screw
4	1	2495 730-1	MOULDING PACKAGE, Radiator Grille Opening Corner (7-16-36)	18	1	2495 496-7	MOULDING PACKAGE, Quarter Panel Upper Rear (23-23-39)
	4	6024 689	Nut		2	6024 271	Screw
5	1	2495 726	MOULDING PACKAGE, Radiator Grille Opening Frame (7-16-36)		4	6001 506	Clip 8 6024 679 Nut
	9	6001 070	Clip		8	6001 548	Clip 2 6001 507 Clip
	9	6023 284	Nut 9 9415 921 Screw	19	1	2244 648-9	MOULDING, Quarter Panel Belt Intermediate (23-23-39)
6	1	2276 410	FRAME, Radiator Grille Opening (7-16-36)		8	6024 478	Fastener
7	3	2417 747	MEDALLION, Radiator Grille (7-17-1)	20	1	2495 700-1	MOULDING PACKAGE, Quarter Panel Upper Front (23-23-39)
	6	6025 434	Nut		8	6001 501	Clip
8	1	2495 180	MOULDING PACKAGE, Hood Front (15-25-2)		2	6024 271	Screw 2 6024 679 Nut
	6	9411 618	Nut	21	1	2421 550-1	MOULDING PACKAGE, Quarter Panel Belt Front (23-23-39)
9	1	2084 997	MOULDING PACKAGE, Windshield Outside Finish Lower Center (23-23-65)		6	6001 497	Retainer
	5	6000 960	Clip	22	1	2421 571-2	MOULDING PACKAGE, Body Side Sill (23-23-2)
10	1	2196 119	PANEL PACKAGE, Windshield Header Outside Finish (23-23-64)		14	6001 100	Retainer
	5	6024 400	Screw		2	2422 576	Clip 4 ---- --- Nut
11	1	2255 710-11	MOULDING and EXTENSION, Windshield Outside Finish Side (23-23-65)		1	2422 574-5	Clip 4 ---- --- Washer
	8	6023 247	Screw	23	1	2448 550-1	MOULDING PACKAGE, Door Belt (23-23-32)
12	1	2243 913	MOULDING, Deck Opening Upper Panel (23-23-31)		10	6001 497	Retainer
	11	6024 478	Fastener		2	6001 087	Retainer 2 9417 621 Nut
13	1	2525 560-1	MOULDING PACKAGE, Quarter Panel Peak (23-23-39)	24	2	2495 450	MOULDING PACKAGE, Front Door Outside (23-23-32)
	14	6024 656	Washer 14 9411 618 Nut		2	6001 544	Clip
14	1	2423 504	"C", Deck Lid Letter (23-19-114)		2	9417 621	Nut 12 6001 545 Retainer
	1	2423 505	"H"				
	2	2423 508	"R"				
	1	2423 507	"Y"				
	1	2423 508	"S"				
	1	2423 509	"L"				
	1	2423 510	"E"				
	8	152 259	Nut				

All Packages include Attaching Parts

Part Type Code is Indicated in Parentheses

EXTERIOR VIEW - CHRYSLER VC1(L) CONVERTIBLE COUPE

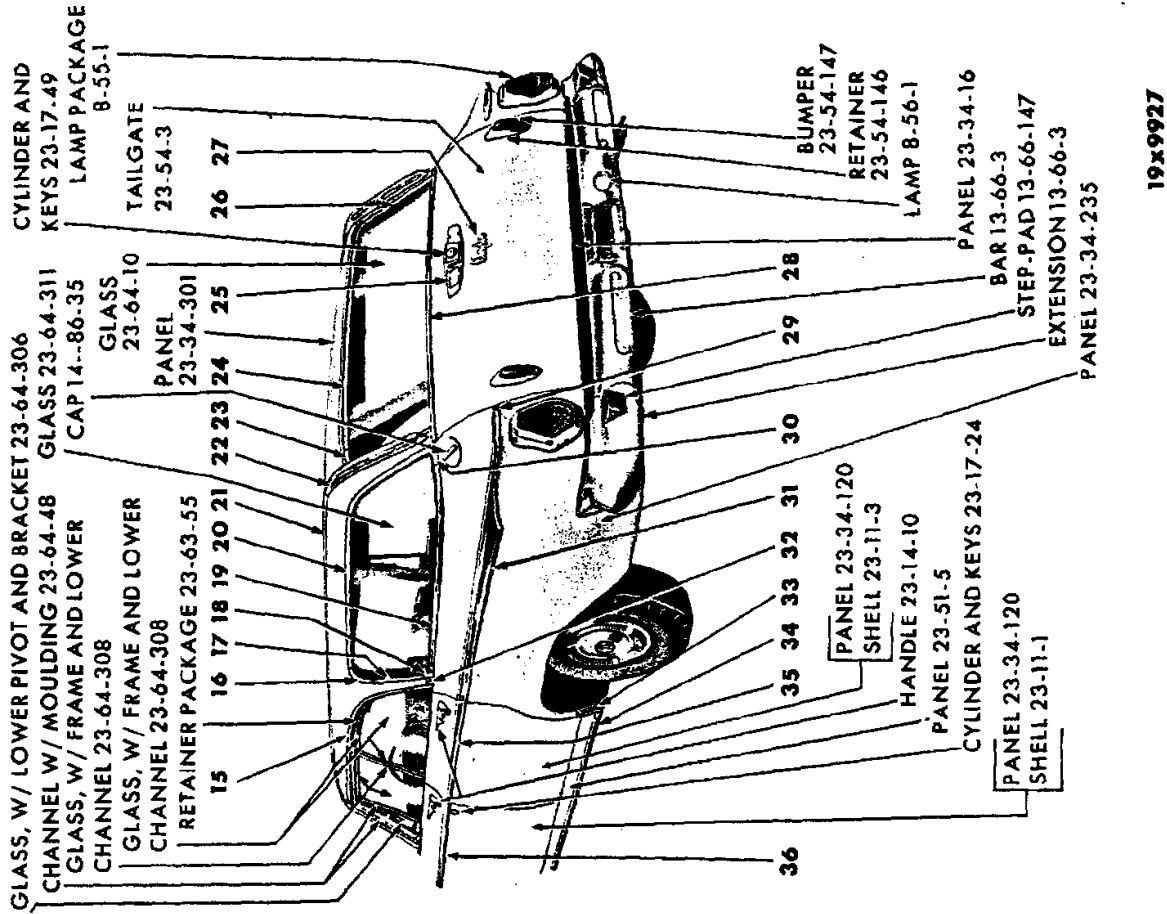

19x9927

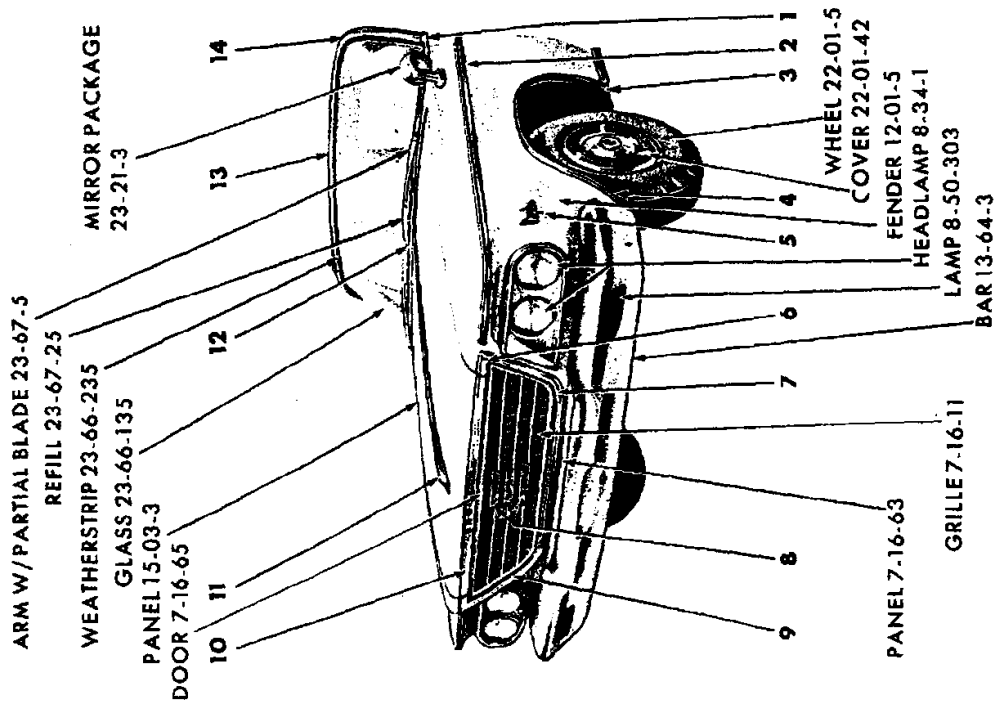

EXTERIOR VIEW - CHRYSLER VCI(L) 4 DOOR HARDTOP STATION WAGON

REF. NO.	QTY	PART NUMBER	DESCRIPTION
1	1	2495 696-7	MOULDING, Windshield Outside Finish Lower End (23-23-65)
	2	274 411	Screw
2	1	2495 706-7	MOULDING PACKAGE, Fender Side (12-15-2)
	10	6001 605	Retainer 4 6001 557 Clip
	12	6001 462	Retainer 12 6024 679 Nut
3	1	2448 556-7	MOULDING PACKAGE, Fender Wheel Opening to Sill (12-15-2)
	2	-----	Clip
	2	6023 247	Screw 2 6006 438 Nut
4	1	2276 470-1	MOULDING PACKAGE, Fender Wheel Opening (12-15-2)
	16	6023 247	Screw
5	2	2276 474	NAME PLATE, Fender Side (12-15-21)
	8	152 259	Nut
6	1	2495 730-1	MOULDING PACKAGE, Radiator Grille Opening Frame Corner (7-16-36)
	4	9411 618	Nut
7	1	2495 726	MOULDING PACKAGE, Radiator Grille Opening Frame (7-16-36)
	9	6001 070	Clip
	9	9415 921	Screw 9 6023 284 Nut
8	3	2417 747	MEDALLION, Radiator Grille (7-17-1)
	6	6025 434	Nut
9	1	2276 410	FRAME, Radiator Grille Opening (7-16-36)
10	1	2495 180	MOULDING PACKAGE, Hood Front (15-25-2)
	6	6023 097	Nut
11	1	2495 181	MOULDING PACKAGE, Hood Top (see print) (15-25-2)
	7	6023 097	Nut
12	1	2084 997	MOULDING PACKAGE, Windshield Outside Finish Lower Center (23-23-65)
	5	6000 685	Clip
13	1	2299 418	MOULDING PACKAGE, Windshield Outside Finish Upper (23-23-65)
	5	6000 927	Clip 2 9414 754 Screw
14	1	2480 458-9	MOULDING, Windshield Outside Finish Side Upper and Lower (23-23-65)
	8	6023 247	Screw
15	1	2093 648-9	MOULDING, Roof Drain Trough Side (23-59-61)
16	1	2094 016-7	CAP, Quarter Window Outside Finish Upper, w/Retainer (23-23-74)
17	1	2094 018-9	MOULDING, Quarter Window Outside Finish Front (23-23-73)
18	2	1961 210	CAP, Quarter Window Outside Finish Lower (23-23-74)
19	1	1961 214-5	MOULDING, Quarter Window Outside Finish Lower (23-23-73)
20	1	1961 212-3	MOULDING, Quarter Window Finish Upper (23-23-73)
21	2	2196 252	MOULDING PACKAGE, Roof Top, used w/Rear Pillar Assist Handle (23-23-42)
	20	6000 923	Clip

REF. NO.	QTY	PART NUMBER	DESCRIPTION
	2	2196 253	MOULDING PACKAGE, Roof Panel Outside Finish, used w/o Assist Handle (23-23-42)
	28	6006 301	Clip
22	2	2196 839	HANDLE PACKAGE, Roof Panel Rear Pillar Assist (23-36-123)
	8	6006 035	Nut
	2	681 135	Bolt
23	1	2196 464-5	CAP PACKAGE, Roof Rear Tailgate Opening Moulding (23-23-60)
	2	6006 451	Clip
24	1	2196 466	MOULDING PACKAGE, Tailgate Opening Outside Finish Roof Rear (23-23-60)
	7	6006 451	Clip
25	1	2188 389	ORNAMENT, Tailgate Outside Panel Electric (23-54-11)
26	1	2196 462-3	MOULDING PACKAGE, Rear Pillar Outside Finish (23-23-60)
	2	6006 451	Clip
27	1	2244 238	NAME PLATE, Tailgate Outside Panel (23-54-11)
	3	6000 604	Speed Clip
28	1	2196 460	MOULDING PACKAGE, Tailgate Outside Finish Belt (23-23-61)
	2	151 306	Screw 2 6006 441 Clip
29	1	2495 482-3	MOULDING PACKAGE, Quarter Panel Lower Rear (23-23-39)
	6	6001 099	Clip
30	1	2196 816-7	CAP PACKAGE, Quarter Window Outside Finish Lower Rear (23-23-74)
	2	125 978	Screw
31	1	2495 488-9	MOULDING PACKAGE, Quarter Panel Lower Front (23-23-39)
	14	6001 547	Clip 2 274 114 Screw
32	1	2299 430-1	MOULDING PACKAGE, Quarter Panel Belt (23-23-39)
	2	6024 401	Screw
33	1	2422 446-7	STONE DEFLECTOR, Quarter Outside Panel Wheel Opening (23-34-240)
	4	6024 564	Screw
34	2	2448 537	MOULDING PACKAGE, Body Side Sill (23-23-2)
	18	6001 605	Retainer
	4	-----	Washer 1 2422 574-5 Clip
	2	2422 576	Clip 4 ----- Nut
35	1	2495 484-5	MOULDING PACKAGE, Rear Door (23-23-33)
	10	6001 505	Retainer
	2	-----	Clip 2 9417 621 Nut
36	2	2495 449	MOULDING PACKAGE, Front Door (23-23-32)
	8	6001 605	Retainer
	4	6001 544	Clip 4 9417 621 Nut

All Packages Include Attaching Parts

Part Type Code is Indicated in Parentheses

EXTERIOR VIEW - CHRYSLER VC1(L) 4 DOOR HARDTOP STATION WAGON

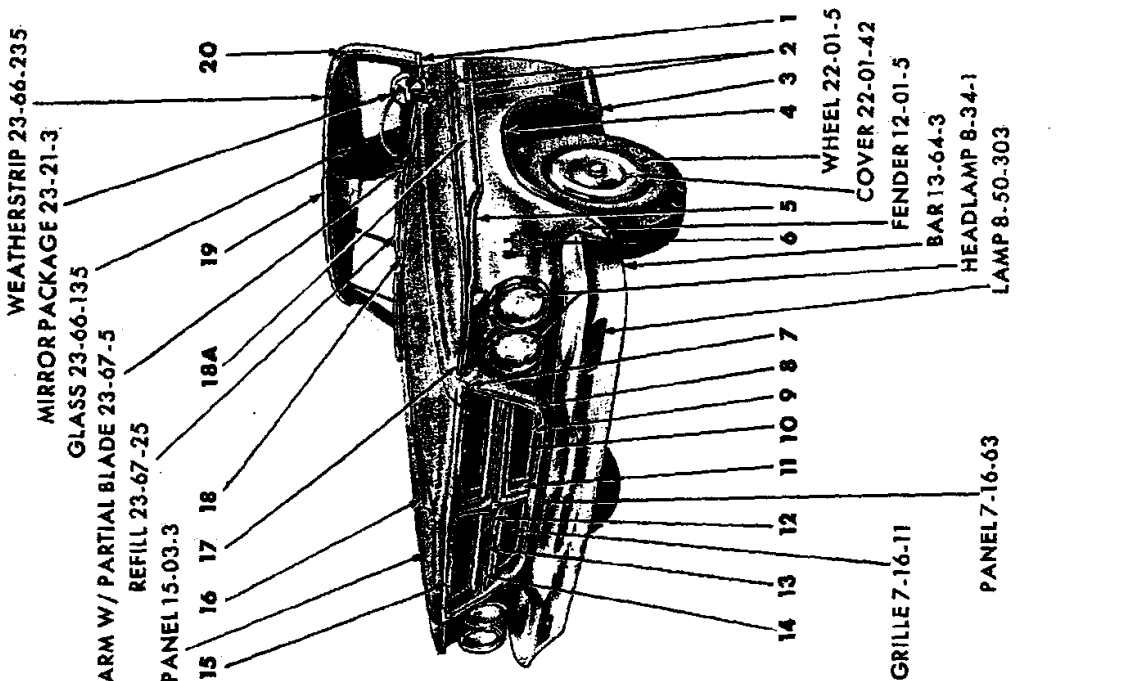
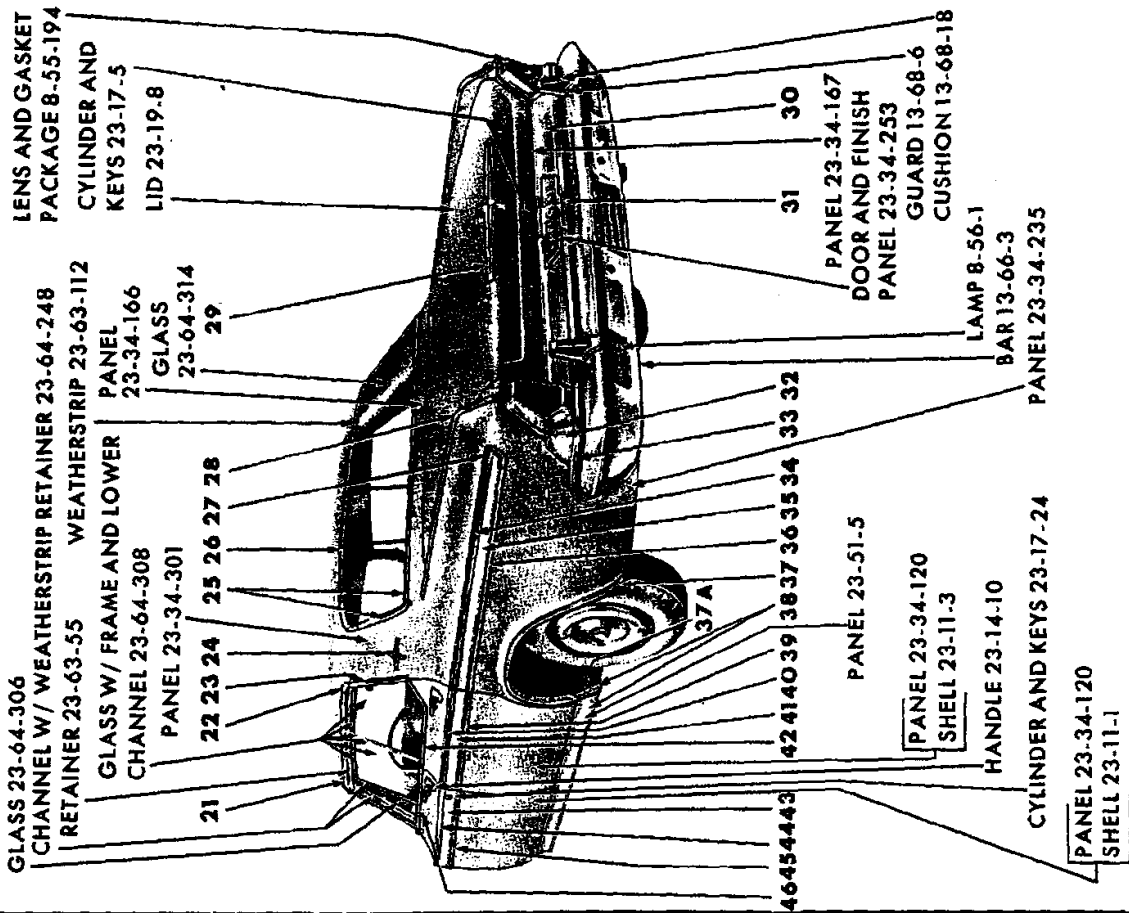

19x9925 B

EXTERIOR VIEW - CHRYSLER V2(M) 4 DOOR HARTOP

REF. NO.	QTY	PART NUMBER	DESCRIPTION	REF. NO.	QTY	PART NUMBER	DESCRIPTION	
1	1	2495 696-7	MOULDING, Windshield Outside Finish Lower End (23-23-65)	25	1	2423 092-3	MOULDING, Rear Window Outside Side and Lower (23-23-52)	
	2	274 411	Screw		12	6001 084	Retainer and Screw	
2	2	2495 708-9	MOULDING PACKAGE, Fender Side (12-15-2)	26	1	2423 091	MOULDING, Rear Window Outside Upper (23-23-52)	
	6	6001 544	Retainer		7	6001 084	Retainer and Screw	
	4	6001 604	Retainer	27	1	2495 464-5	MOULDING PACKAGE, Quarter Panel End (23-23-39)	
3	1	2448 556-7	MOULDING PACKAGE, Fender Wheel Opening to Sill (12-15-2)		6	6023 260	Nut	
	2	----	Clip	28	1	2525 560-1	MOULDING PACKAGE, Quarter Panel Peak (23-23-39)	
	2	6006 438	Nut		14	6024 656	Washer	
4	1	2276 470-1	MOULDING PACKAGE, Fender Wheel Opening (12-15-2)	29	1	2481 225	MEDALLION, Deck Lid (23-19-114)	
	16	6023 247	Screw		5	-----	Washer	
5	1	2495 710-1	CAP PACKAGE, Fender Side Moulding (12-15-2)	30	1	2424 990-1	PANEL, Deck Lower Panel Finish (23-23-28)	
	8	152 272	Nut		12	6022 997	Washer	
6	2	2276 474	NAME PLATE, Fender Side (12-15-21)	31	1	2421 448	MOULDING PACKAGE, Deck Lower Panel Filler Door (23-23-23)	
	8	152 259	Nut		2	6000 709	Clip	
7	1	2495 730-1	MOULDING PACKAGE, Radiator Grille Opening Corner (7-16-36)	32	1	2424 988-9	PANEL, Quarter Outside Finish (23-23-85)	
	4	6025 434	Nut		2	6023 682	Screw	
8	1	2495 726	MOULDING PACKAGE, Radiator Grille Opening Frame (7-16-36)	33	1	2448 428-9	MOULDING PACKAGE, Quarter Panel Lower Rear (23-23-39)	
	9	6001 070	Clip		10	6001 099	Retainer	
	9	6023 284	Nut		2	188 973	Screw	
9	1	2495 728-9	MOULDING PACKAGE, Radiator Grille (7-16-36)	34	1	2495 460-1	MOULDING PACKAGE, Quarter Panel Upper (23-23-39)	
	8	6001 496	Retainer		2	6001 462	Retainer	
10	1	2276 410	FRAME, Radiator Grille Opening (7-16-36)		12	6001 545	Retainer	
11	1	2417 749	BAR, Radiator Grille (7-16-47)	35	2	2483 142	PANEL, Quarter Outside Finish (23-23-85)	
12	1	2417 751	MEDALLION, Radiator Grille Center (7-17-1)	36	1	2495 462-3	MOULDING PACKAGE, Quarter Panel Lower (23-23-39)	
13	1	2445 002-3	MEDALLION, Radiator Grille Outer (7-17-1)		2	6001 462	Retainer	
14	1	2445 001	BASE, Radiator Grille Medallion (7-17-2)		12	6001 545	Retainer	
15	1	2495 180	MOULDING PACKAGE, Hood Front (15-25-2)	37	1	2423 740-1	MOULDING, Quarter Panel Wheel Opening (23-23-39)	
	6	9411 618	Nut		16	6024 271	Screw	
16	1	2495 181	MOULDING PACKAGE, Hood Top (15-25-2)	37A	1	2243 712-3	MOULDING, Quarter Panel Wheel Opening to Sill (23-23-39)	
	7	6023 097	Nut		38	1	2421 573-4	MOULDING PACKAGE, Body Side Sill, w/Cap (23-23-2)
17	1	2495 704-5	MOULDING PACKAGE, Fender Front (12-15-2)		18	6001 605	Retainer	
	12	6001 544	Retainer		2	6022 052	Washer	
	12	6024 711	Washer	39	1	2495 456-7	MOULDING PACKAGE, Rear Door Lower (23-23-33)	
18	1	2084 997	MOULDING PACKAGE, Windshield Outside Lower Center (23-23-65)		10	6001 545	Retainer	
	5	6000 685	Clip		2	6001 544	Clip	
18A	2	2445 592	INSERT, Fender Side Moulding (12-15-4)	40	1	2495 454-5	MOULDING PACKAGE, Rear Door Upper (23-23-33)	
19	1	2495 694	MOULDING PACKAGE, Windshield Outside Finish Upper Center (23-23-65)		10	6001 545	Retainer	
	5	6000 927	Clip		2	6001 544	Clip	
20	1	2216 870-1	MOULDING, Windshield Outside Finish Side (23-23-85)	41	2	2483 138	PANEL, Rear Door Outside Finish (23-23-80)	
	8	6023 247	Screw	42	1	2421 559-659	MOULDING PACKAGE, Rear Door Belt (23-23-33)	
21	1	2243 734-5	MOULDING, Roof Side Drain Trough Front (23-59-61)		8	6001 497	Retainer	
22	1	2243 738-9	CAP, Roof Side Drain Trough Moulding Joint (23-59-57)	43	2	2483 136	PANEL, Front Door Outside Finish (23-23-80)	
23	1	2482 782-3	MOULDING, w/Joist Cap, Roof Side Drain Trough Rear (23-59-61)	44	2	2495 448	MOULDING PACKAGE, Front Door Upper (23-23-32)	
	6	6024 271	Screw w/Washer		4	6001 544	Clip	
24	2	2417 890	MEDALLION, Quarter Outside (23-34-334)	45	2	2495 452	MOULDING PACKAGE, Front Door Lower (23-23-32)	
	2	2445 005	BASE, Quarter Outside Medallion (23-34-340)		4	6001 544	Clip	
	8	6000 050	Speed Clip	46	1	2448 552-3	MOULDING PACKAGE, Front Door Belt (23-23-32)	
					8	6001 497	Retainer	
					2	6001 087	Retainer	

All Packages include Attaching Parts

Part Type Code is Indicated in Parentheses

EXTERIOR VIEW - CHRYSLER VC2(M) 4 DOOR HARDTOP

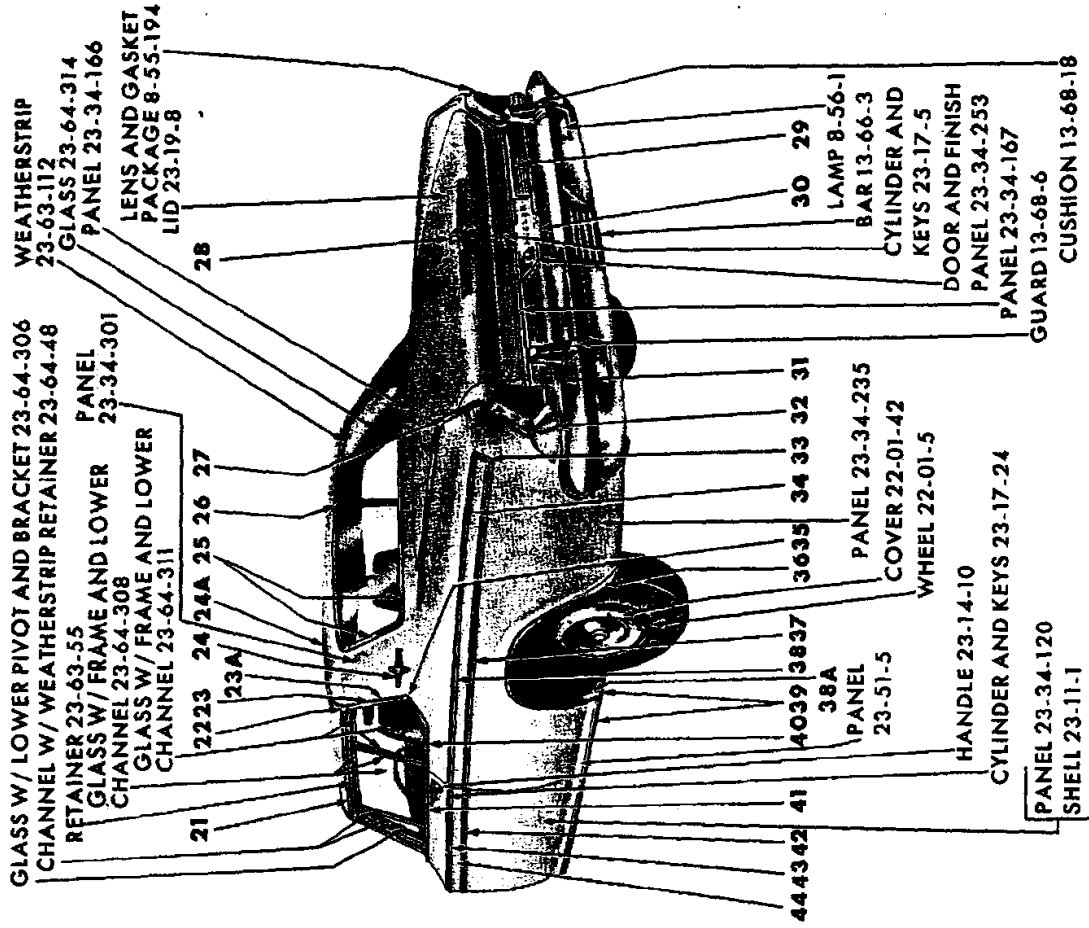

19x9921 B

EXTERIOR VIEW - CHRYSLER VC2(M) 2 DOOR HARDTOP

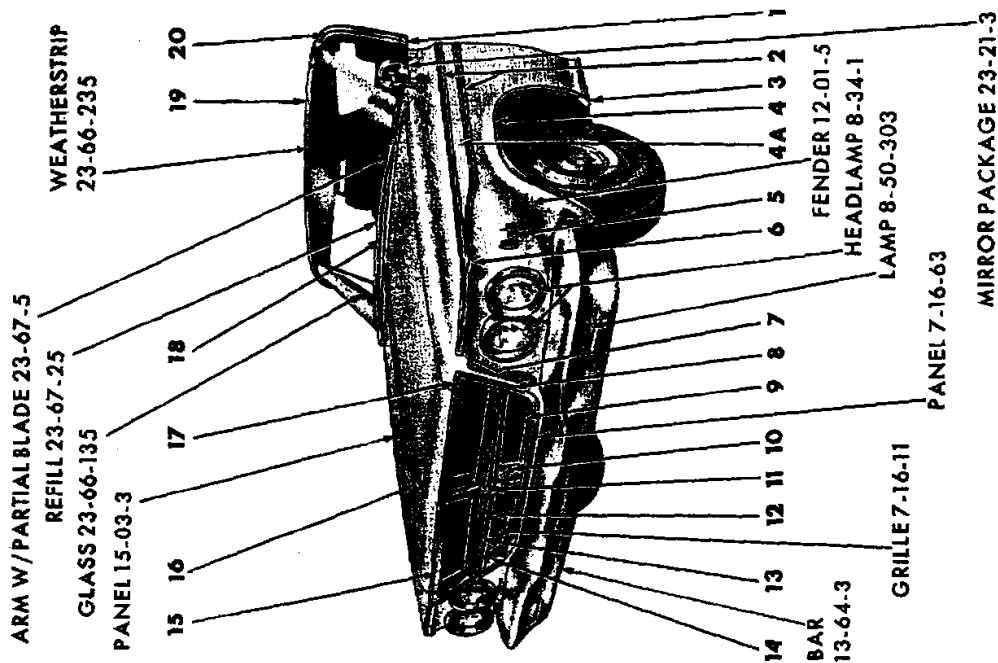

REF. NO.	QTY	PART NUMBER	DESCRIPTION	REF. NO.	QTY	PART NUMBER	DESCRIPTION
1	1	2495 696-7	MOULDING, Windshield Outside Finish Lower End(23-23-65)	20	1	2216 870-1	MOULDING, Windshield Outside Finish Side (23-23-65)
	2	274 411	Screw	8	6023 247		Screw
2	2	2495 708-9	MOULDING PACKAGE, Fender Side (12-15-2)	21	1	2243 734-5	MOULDING, Roof Side Drain Trough Front (w/o Vinyl Roof) (23-59-61)
	12	6001 544	Retainer	1	2480 000-1		MOULDING, Roof Side Drain Trough (w/Vinyl Roof) (23-59-61)
	4	6001 604	Retainer	22	1	2243 738	CAP, Roof Side Drain Trough Moulding Joint (23-59-57)
	2	6001 557	Clip	23	1	2482 782-3	MOULDING, w/Joint Cap, Roof Side Drain Trough Rear (23-59-61)
	6	6024 711	Washer	6	6024 271		Screw w/Sealer
	6	6023 202	Nut	23A	1	2424 066-7	MOULDING, Roof Panel Outside Side (23-23-42)
3	1	2448 556-7	MOULDING PACKAGE, Fender Wheel Opening to Sill (12-15-2)	4	6024 271		Screw and Sealer
	2	-----	Clip	24	2	2417 890	MEDALLION, Quarter Outside (23-34-334)
	2	6006 438	Nut	2	2445 005		BASE, Quarter Outside Medallion (23-34-340)
	2	6023 247	Screw	24A	1	2448 549	MOULDING PACKAGE, Roof Panel Outside Rear (23-23-42)
4	1	2276 470-1	MOULDING PACKAGE, Fender Wheel Opening (12-15-2)	4	6001 455		Clip
	16	6023 247	Screw	4	-----		Nut
4A	2	2445 592	INSERT, Fender Side Moulding (12-15-4)	25	1	2423 092-3	MOULDING, Rear Window Outside Side and Lower (23-23-52)
5	2	2276 474	NAME PLATE, Fender Side (12-15-21)	12	6001 084		Retainer and Screw
	8	152 259	Nut	26	1	2423 091	MOULDING, Rear Window Outside Upper (23-23-52)
6	1	2495 710-1	CAP PACKAGE, Fender Side Moulding (12-15-9)	7	6001 084		Retainer and Screw
	8	152 272	Nut	27	1	2525 560-1	MOULDING PACKAGE, Quarter Panel Peak (23-23-39)
7	1	2495 704-5	MOULDING PACKAGE, Fender Front (12-15-2)	14	6024 656		Washer
	12	6001 544	Retainer	14	9411 618		Nut
	12	6024 711	Washer	28	1	2481 225	MEDALLION, Deck Lid (23-19-114)
	12	6023 202	Nut	5	-----		Washer
8	1	2495 726	MOULDING PACKAGE, Radiator Grille Opening Frame(7-16-36)	5	-----		Nut
	9	6001 070	Clip	29	1	2424 990-1	PANEL, Deck Lower Panel Finish (23-23-28)
	9	6023 284	Nut	12	6022 997		Washer
	9	9415 921	Screw	12	6023 885		Nut
9	1	2495 728-9	MOULDING PACKAGE, Radiator Grille (7-16-36)	30	1	2421 448	MOULDING PACKAGE, Deck Lower Panel Filler Door (23-23-23)
	8	6001 496	Retainer	2	6000 709		Clip
10	1	2417 749	BAR, Radiator Grille (7-16-47)	2	6024 679		Nut
11	1	2417 751	MEDALLION, Radiator Grille Center (7-17-1)	31	1	2448 428-9	MOULDING PACKAGE, Quarter Panel Lower Rear(23-23-39)
12	1	2445 001	BASE, Radiator Grille Medallion (7-17-2)	10	6001 099		Retainer
13	1	2445 002-3	MEDALLION, Radiator Grille Outer (7-17-1)	10	6024 679		Nut
14	1	2276 410	FRAME, Radiator Grille Opening (7-16-36)	2	188 973		Screw
15	1	2495 180	MOULDING PACKAGE, Hood Front (15-25-2)	4	-----		Nut
	6	9411 618	Nut	32	1	2424 988-9	PANEL, Quarter Outside Finish (23-23-85)
16	1	2495 181	MOULDING PACKAGE, Hood Top (15-25-2)	2	6023 682		Screw
	7	6023 097	Nut	2	-----		Seal
17	1	2495 730-1	MOULDING PACKAGE, Radiator Grille Opening Corner(7-16-36)	33	1	2495 464-5	MOULDING PACKAGE, Quarter Panel End (23-23-39)
	4	6025 434	Nut	6	6023 260		Nut
18	1	2084 997	MOULDING PACKAGE, Windshield Outside Finish Lower Center (23-23-65)	34	2	2483 140	PANEL, Quarter Outside Finish (23-23-85)
	5	6000 685	Clip				
19	1	2495 694	MOULDING PACKAGE, Windshield Outside Finish Upper Center (23-23-65)				
	5	6000 927	Clip				
	2	6023 277	Screw				

All Packages include Attaching Parts

Part Type Code is Indicated in Parentheses

EXTERIOR VIEW - CHRYSLER VC2(M) 2 DOOR HARDTOP

1964 PASSENGER CAR PARTS CATALOG

BODY

REF. NO.	QTY	PART NUMBER	DESCRIPTION	REF. NO.	QTY	PART NUMBER	DESCRIPTION
35	1	2528 992	MOULDING, Roof Side Drain Trough Rear Lower (23-59-61)	40	1	2421 554-5	MOULDING PACKAGE, Quarter Panel Belt (23-23-39)
36	1	2423 740-1	MOULDING, Quarter Panel Wheel Opening (23-23-39)		8	6001 497	Retainer
	16	6024 271	Screw	41	1	2448 550-1	MOULDING PACKAGE, Door Belt (23-23-32)
37	1	2495 458-9	MOULDING PACKAGE, Quarter Panel Lower (23-23-39)		10	6001 497	Retainer
	2	8001 544	Retainer		2	6001 087	Retainer
20	20	6001 545	Retainer	42	2	9417 621	Nut
	2	6024 271	Screw		2	2495 451	MOULDING PACKAGE, Door Lower (23-23-32)
	2	6024 679	Nut		2	9417 621	Nut
38	1	2495 458-9	MOULDING PACKAGE, Quarter Panel Upper (23-23-39)		12	6001 545	Retainer
	2	6001 544	Retainer	43	2	6001 544	Clip
20	20	6001 545	Retainer		2	2495 451	MOULDING PACKAGE, Door Upper (23-23-32)
	2	6024 271	Screw		2	9417 621	Nut
	2	6024 679	Nut		12	6001 545	Retainer
38A	1	2243 712-3	MOULDING, Quarter Panel Wheel Opening to Sill (23-23-39)		2	6001 544	Clip
	2	6001 544	Retainer	44	2	2483 134	PANEL, Door Outside Finish (23-23-80)
39	1	2421 573-4	MOULDING PACKAGE, Body Side Sill, w/Cap (23-23-2)		2	9417 621	Nut
	18	6001 605	Retainer		12	6001 545	Retainer
	2	6022 052	Washer		2	6001 544	Clip
	2	----	Nut		2	2483 134	PANEL, Door Outside Finish (23-23-80)

All Packages Include Attaching Parts

Part Type Code is Indicated in Parentheses

EXTERIOR VIEW - CHRYSLER VC2(M) 2 DOOR HARDTOP

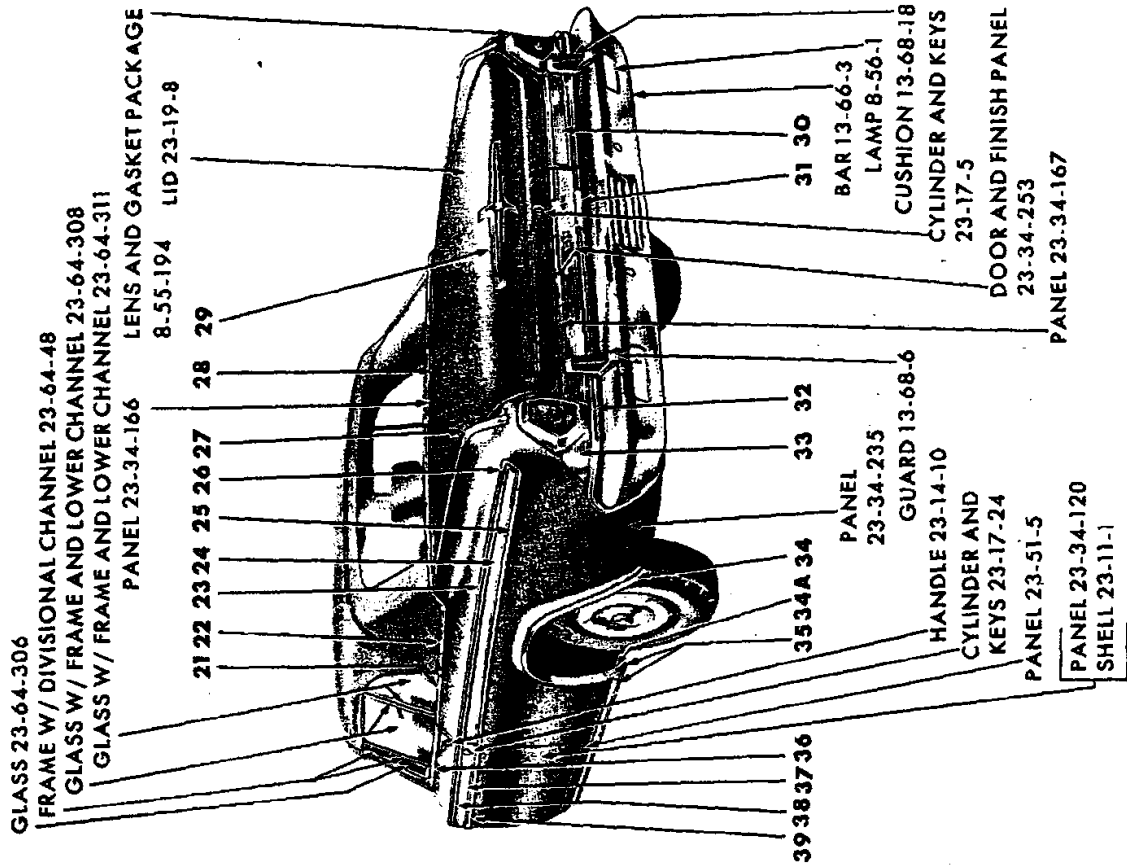

19x9922B

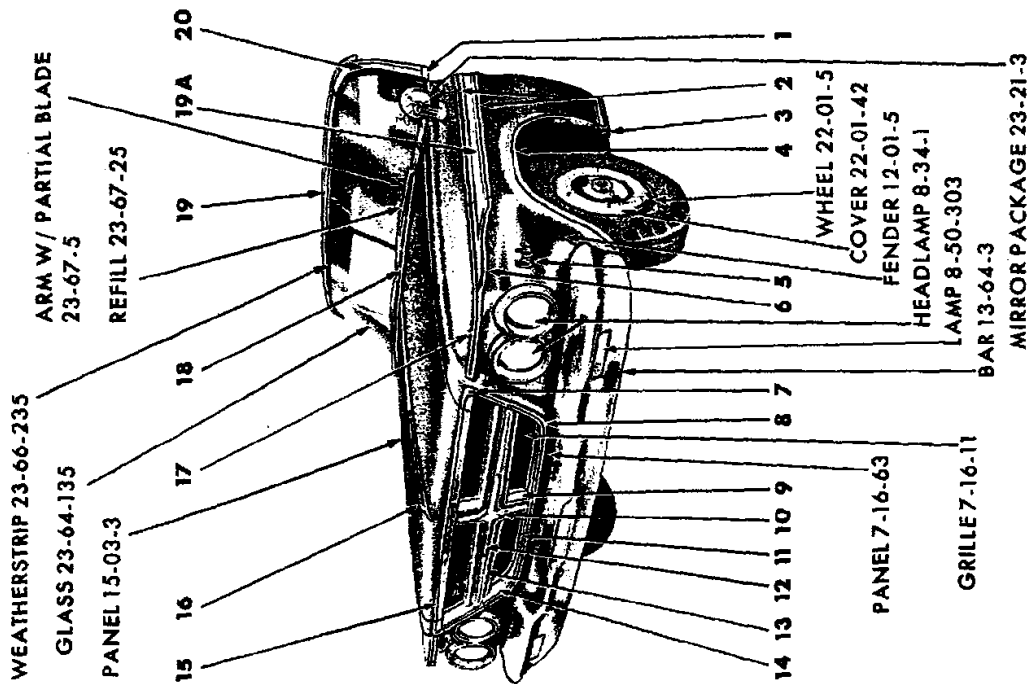

EXTERIOR VIEW - CHRYSLER VC3(M) CONVERTIBLE COUPE

1964 PASSENGER CAR PARTS CATALOG

BODY

Page 23-129

REF. NO.	QTY	PART NUMBER	DESCRIPTION	REF. NO.	QTY	PART NUMBER	DESCRIPTION
1	1	2495 696-7	MOULDING, Windshield Outside Finish Lower End (23-23-65)	21	1	2421 550-1	MOULDING PACKAGE, Quarter Panel Belt Front (23-23-39)
	2	274 211	Screw		6	6001 497	Retainer
2	2	2495 708-9	MOULDING PACKAGE, Fender Side (12-15-2)	22	1	2244 648-9	MOULDING, Quarter Panel Belt Intermediate (23-23-39)
	12	6001 544	Retainer 12 6024 711 Washer		8	6024 478	Fastener
	8	6001 604	Retainer 12 6023 202 Nut	23	1	2495 458-9	MOULDING PACKAGE, Quarter Panel Upper (23-23-39)
3	1	2448 556-7	MOULDING PACKAGE, Fender Wheel Opening to Sill (12-15-2)		2	6024 271	Screw
	2	----	Clip		2	6001 544	Retainer
	2	6006 438	Nut 2 6023 247 Screw		20	6001 545	Retainer 2 6024 679 Nut
4	1	2276 470-1	MOULDING PACKAGE, Fender Wheel Opening (12-15-2)	24	2	2483 140	PANEL, Quarter Outside Finish (23-23-85)
	16	6023 247	Screw	25	1	2495 458-9	MOULDING PACKAGE, Quarter Panel Lower (23-23-39)
5	2	2276 474	NAME PLATE, Fender Side (12-15-21)		2	6001 544	Retainer 2 6024 271 Screw
	8	152 259	Nut		20	6001 545	Retainer 2 6024 679 Nut
6	1	2495 710-1	CAP PACKAGE, Fender Side Moulding (12-15-9)	26	1	2495 464-5	MOULDING PACKAGE, Quarter Panel End (23-23-39)
	8	152 272	Nut		6	6023 260	Nut
7	1	2495 730-1	MOULDING PACKAGE, Radiator Grille Opening Corner (7-16-36)	27	1	2525 560-1	MOULDING PACKAGE, Quarter Panel Peak (23-23-39)
	4	6025 434	Nut		14	6024 656	Washer 14 9411 618 Nut
8	1	2495 726	MOULDING PACKAGE, Radiator Grille Opening Frame (7-16-36)	28	1	2243 913	MOULDING, Deck Upper Panel (23-23-31)
	9	6001 070	Clip		11	6024 478	Fastener
	9	6023 284	Nut 9 9415 921 Screw	29	1	2481 225	MEDALLION, Deck Lid (23-19-114)
9	1	2417 749	BAR, Radiator Grille (7-16-47)		5	----	Washer 5 ---- Nut
10	1	2417 751	MEDALLION, Radiator Grille Center (7-17-1)	30	1	2424 990-1	PANEL, Deck Lower Panel Finish (23-23-28)
11	1	2495 728-9	MOULDING PACKAGE, Radiator Grille (7-16-36)		12	6022 997	Washer 12 6023 685 Nut
	8	6001 496	Retainer	31	1	2421 448	MOULDING PACKAGE, Deck Lower Filler Door (23-23-23)
12	1	2445 001	BASE, Radiator Grille Medallion (7-17-2)		2	6000 709	Clip 2 6023 265 Nut
13	1	2445 002-3	MEDALLION, Radiator Grille Outer (7-17-1)	32	1	2448 428-9	MOULDING PACKAGE, Quarter Panel Lower Rear (23-23-39)
14	1	2276 410	FRAME, Radiator Grille Opening (7-16-36)		10	6001 099	Retainer 10 6024 679 Nut
15	1	2495 180	MOULDING PACKAGE, Hood Front (15-25-2)		2	188 973	Screw 4 ---- Nut
	6	9411 618	Nut	33	1	2424 988-9	PANEL, Quarter Outside Finish (23-23-85)
16	1	2495 181	MOULDING PACKAGE, Hood Top (15-25-2)		2	6023 682	Screw 2 ---- Seal
	7	6023 097	Nut	34	1	2423 740-1	MOULDING, Quarter Panel Wheel Opening (23-23-39)
17	1	2495 704-5	MOULDING PACKAGE, Fender Front (12-15-2)		16	6024 271	Screw
	12	6001 544	Retainer	34A	1	2243 712-3	MOULDING, Quarter Panel Wheel Opening to Sill (23-23-39)
	12	6023 202	Nut 12 6024 711 Washer	35	1	2421 573-4	MOULDING PACKAGE, Body Side Sill, w/Cap (23-23-2)
18	1	2084 997	MOULDING PACKAGE, Windshield Outside Finish Lower Center (23-23-85)		18	6001 605	Retainer
	5	6000 960	Clip		2	6022 052	Washer 2 ---- Nut
19	1	2196 119	PANEL PACKAGE, Windshield Header Outside Finish (23-23-64)	36	1	2448 550-1	MOULDING PACKAGE, Door Belt (23-23-32)
	5	6024 400	Screw		10	6001 497	Retainer
19A	2	2445 592	INSERT, Fender Side Moulding (12-15-4)		2	6001 087	Retainer 2 9417 621 Nut
20	1	2255 710-1	MOULDING and EXTENSION, Windshield Outside Finish Side (23-23-65)	37	2	2483 134	PANEL, Door Outside Finish (23-23-80)
	8	6023 247	Screw	38	2	2495 451	MOULDING PACKAGE, Quarter Panel Upper (23-23-39)
					2	9417 621	Nut
					2	6001 544	Clip 12 6001 545 Retainer
				39	2	2495 451	MOULDING PACKAGE, Quarter Panel Lower (23-23-32)
					2	9417 621	Nut
					12	6001 545	Retainer 2 6001 544 Clip

All Packages include Attaching Parts

Part Type Code is Indicated in Parentheses

EXTERIOR VIEW - CHRYSLER VC2(M) CONVERTIBLE COUPE

1964 PASSENGER CAR PARTS CATALOG

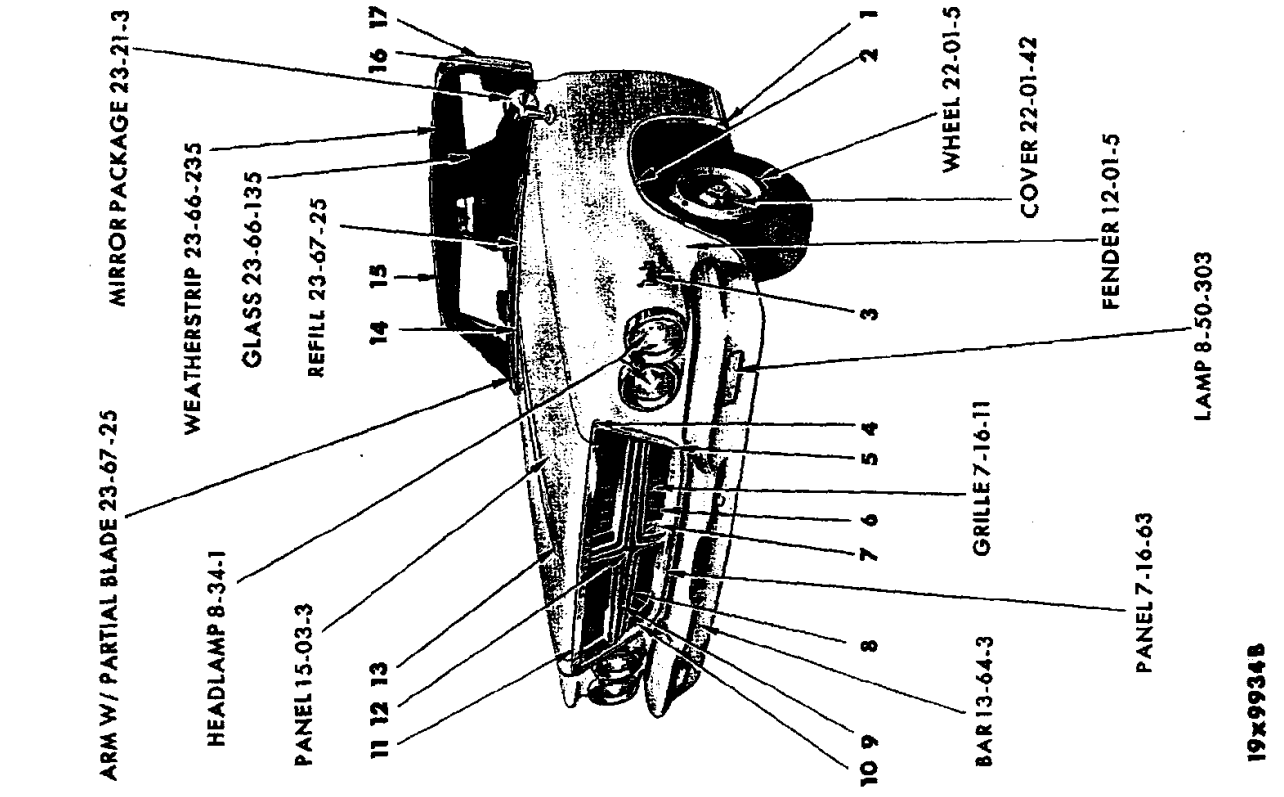
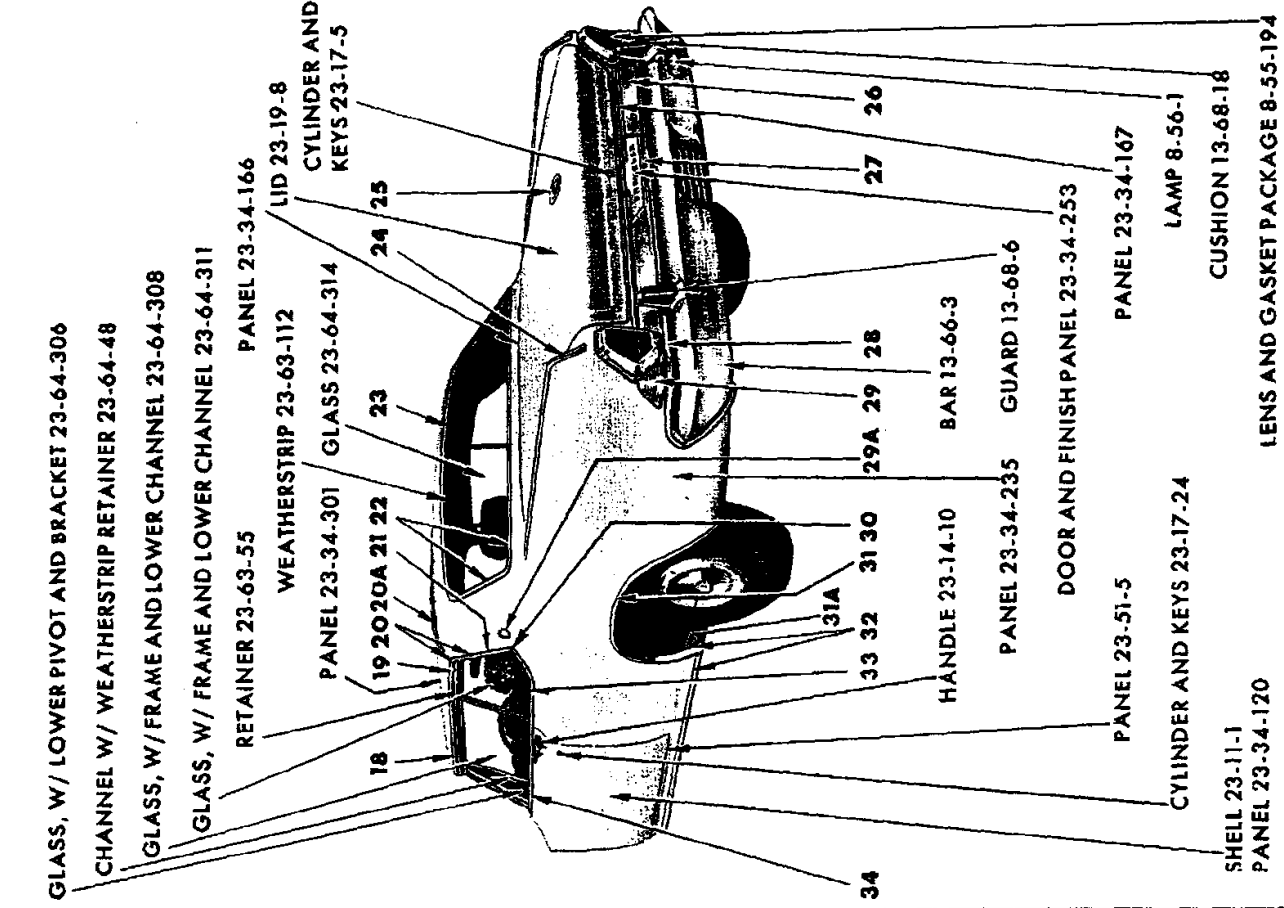

EXTERIOR VIEW - CHRYSLER VC2-300K 2 DOOR HARTDOP

19X99348

REF. NO.	QTY	PART NUMBER	DESCRIPTION	REF. NO.	QTY	PART NUMBER	DESCRIPTION
1	1	2448 556-7	MOULDING PACKAGE, Fender Wheel Opening to Sill (12-15-2)	20A	1	2448 549	MOULDING PACKAGE, Roof Panel Outside Rear (23-23-42)
	2	-----	Clip	4	6001 455		Clip and Seal
	2	6006 438	Nut	4	-----		Nut
	2	6023 247	Screw	21	1	2424 066-7	MOULDING, Roof Panel Outside Side (23-23-42)
2	1	2276 470-1	MOULDING PACKAGE, Fender Wheel Opening (12-15-2)	4	6024 271		Screw and Sealer
	16	6023 247	Screw	22	1	2423 092-3	MOULDING, Rear Window Outside Side and Lower (23-23-52)
3	2	2276 474	NAME PLATE, Fender Side (12-15-21)	12	6001 084		Retainer and Screw
	8	152 259	Nut	23	1	2423 091	MOULDING, Rear Window Outside Upper (23-23-52)
4	1	2495 730-1	MOULDING PACKAGE, Radiator Grille Opening Corner (7-16-36)	7	6001 084		Retainer and Screw
	4	6024 689	Nut	24	1	2525 560-1	MOULDING PACKAGE, Quarter Panel Peak (23-23-39)
5	1	2495 726	MOULDING PACKAGE, Radiator Grille Opening Frame (7-16-36)	14	6024 656		Washer
	9	6001 070	Clip	14	9411 618		Nut
	9	6023 284	Nut	25	1	2482 755	MEDALLION, Deck Lid (23-19-114)
	9	9415 921	Screw	1	6022 013		Washer
6	1	2495 728-9	MOULDING PACKAGE, Radiator Grille (7-16-36)	1	116 000		Nut
	8	6001 496	Retainer	26	1	2424 990-1	PANEL, Deck Lower Panel Finish (23-23-28)
7	1	2417 749	BAR, Radiator Grille (7-16-47)	12	6022 987		Washer
8	1	2445 001	BASE, Radiator Grille Medallion (7-17-2)	12	6023 685		Nut
9	1	2445 002-3	MEDALLION, Radiator Grille Outer (7-17-1)	27	1	2421 448	MOULDING PACKAGE, Deck Lower Panel Filler Door (23-23-23)
10	1	2276 410	FRAME, Radiator Grille Opening (7-16-36)	2	6000 709		Clip
11	1	2495 180	MOULDING PACKAGE, Hood Front (15-25-2)	2	6024 679		Nut
	6	9411 618	Nut	28	1	2448 428-9	MOULDING PACKAGE, Quarter Panel Lower Rear (23-23-39)
12	1	2417 751	MEDALLION, Radiator Grille Center (7-17-1)	10	6001 099		Retainer
13	1	2495 181	MOULDING PACKAGE, Hood Top (15-25-2)	2	188 973		Screw
	7	6023 097	Nut	10	6024 679		Nut
14	1	2084 997	MOULDING PACKAGE, Windshield Outside Finish Lower Center (23-23-65)	4	-----		Nut
	5	6000 685	Clip	29	1	2424 988-9	PANEL, Quarter Outside Finish (23-23-85)
15	1	2495 694	MOULDING PACKAGE, Windshield Outside Finish Upper Center (23-23-65)	2	6023 682		Screw
	5	6000 927	Clip	2	-----		Seal
	2	6023 277	Screw	29A	2	2482 755	MEDALLION, Quarter Outside Panel (23-34-334)
16	1	2495 696-7	MOULDING, Windshield Outside Finish Lower End (23-23-65)	2	1946 415		Seal
	2	274 411	Screw	2	116 000		Nut
17	1	2216 870-1	MOULDING, Windshield Outside Finish Side (23-23-65)	2	6022 013		Seal
	8	6023 247	Screw	30	1	2528 992-3	MOULDING, Roof Side Drain Trough Rear Lower (23-59-61)
18	1	2243 734-5	MOULDING, Roof Side Drain Trough Front (23-59-61)	31	1	2423 740-1	MOULDING, Quarter Panel Wheel Opening (23-23-39)
19	1	2243 738-9	CAP, Roof Side Drain Trough Moulding Joint (23-59-57)	16	6024 271		Screw
20	1	2482 782-3	MOULDING w/Joint Cap, Roof Side Drain Trough Rear (23-59-61)	31A	1	2243 712-3	MOULDING, Quarter Panel Wheel Opening to Sill (23-23-39)
				32	1	2421 573-4	MOULDING PACKAGE, Body Side Sill, w/Cap (23-23-2)
				18	6001 605		Retainer
				2	-----		Washer
				2	-----		Nut
				33	1	2421 554-5	MOULDING PACKAGE, Quarter Panel Belt (23-23-39)
				6	6001 497		Retainer
				34	1	2448 550-1	MOULDING PACKAGE, Door Belt (23-23-32)
				10	6001 497		Retainer
				2	6001 087		Retainer
				2	9417 621		Nut

All Packages include Attaching Parts

Part Type Code is Indicated in Parentheses

EXTERIOR VIEW - CHRYSLER VC2-300K 2 DOOR HARDTOP

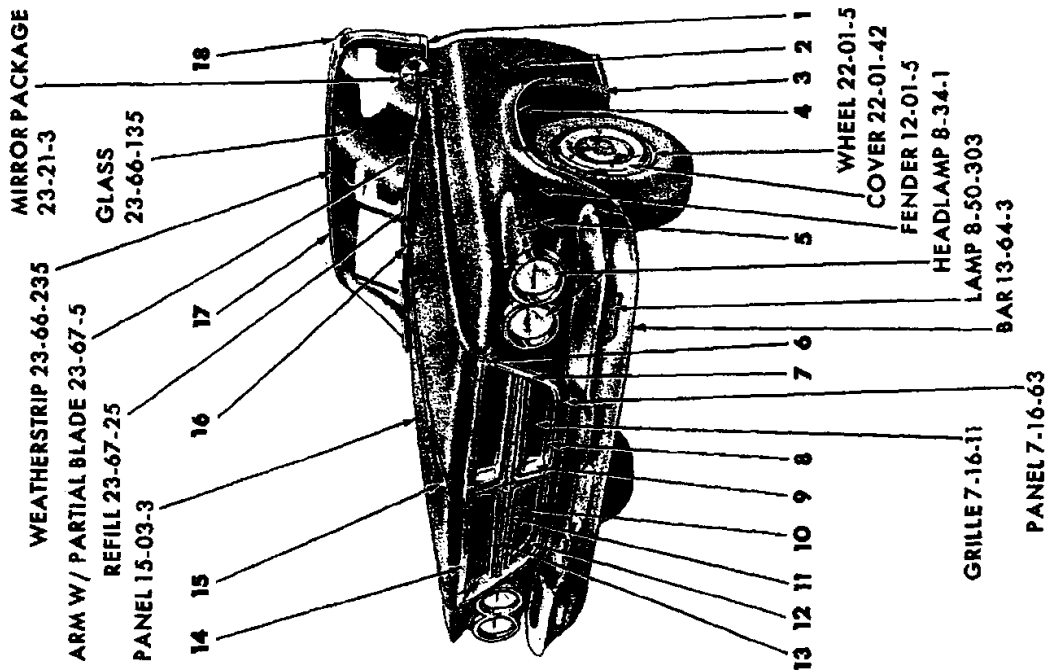
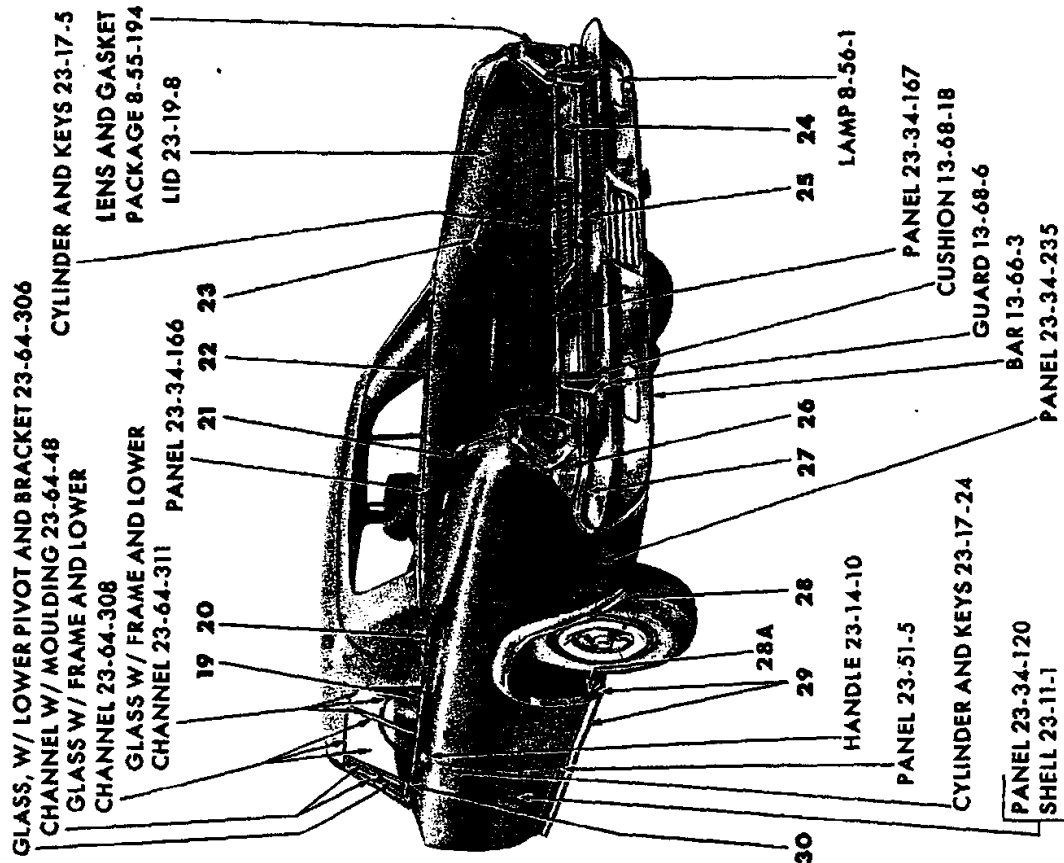

EXTERIOR VIEW - CHRYSLER VC2-300K CONVERTIBLE COUPE

19x9935 A

REF. NO.	QTY	PART NUMBER	DESCRIPTION
1	1	2495 696-7	MOULDING, Windshield Outside Finish Lower End (23-23-65)
	2	274 411	Screw
2	2	2527 978	MEDALLION, Fender Side (12-15-21)
	2	6000 960	Clip
3	1	2448 556-7	MOULDING PACKAGE, Fender Wheel Opening to Sill (12-15-2)
	2	6001 062	Clip
	2	6023 247	Screw 2 6006 438 Nut
4	1	2276 470-1	MOULDING PACKAGE, Fender Wheel Opening (12-15-2)
	16	6023 247	Screw
5	2	2276 474	NAME PLATE, Fender Side (12-15-21)
	8	152 259	Nut
6	1	2495 730-1	MOULDING PACKAGE, Radiator Grille Opening Frame Corner (7-16-36)
	4	9411 618	Nut
7	1	2495 726	MOULDING PACKAGE, Radiator Grille Opening Frame (7-16-36)
	9	6001 070	Clip
	9	6023 284	Nut 9 9415 921 Screw
8	1	2276 410	FRAME, Radiator Grille Opening (7-16-36)
9	1	2417 749	BAR, Radiator Grille (7-16-47)
10	1	2445 001	BASE, Radiator Grille Bar Medallion (7-17-2)
11	1	2417 751	MEDALLION, Radiator Grille Bar Center (7-17-1)
12	1	2495 728-9	MOULDING PACKAGE, Radiator Grille (7-16-36)
	8	6001 496	Retainer
13	1	2445 002-3	MEDALLION, Radiator Grille Bar Outer (7-17-1)
14	1	2495 180	MOULDING PACKAGE, Hood Front (15-25-2)
	6	9411 618	Nut
15	1	2495 181	MOULDING PACKAGE, Hood Top (15-25-2)
	7	6023 097	Nut
16	1	2084 997	MOULDING PACKAGE, Windshield Outside Finish Lower Center (23-23-65)
	5	6006, 685	Clip

REF. NO.	QTY	PART NUMBER	DESCRIPTION
17	1	2196 119	PANEL PACKAGE, Windshield Header Outside Finish (23-23-64)
	5	6024 400	Screw
18	1	2255 710-11	MOULDING and EXTENSION, Windshield Outside Finish Side (23-23-65)
	8	6023 247	Screw
19	1	2421 550-1	MOULDING PACKAGE, Quarter Panel Belt Front (23-23-39)
	6	6001 497	Retainer
20	1	2244 648-9	MOULDING, Quarter Panel Belt Rear (23-23-39)
	8	6024 478	Fastener
21	1	2525 560-1	MOULDING PACKAGE, Quarter Panel Upper (23-23-39)
	14	6024 656	Washer 14 9411 618 Nut
22	1	2243 913	MOULDING, Deck Upper Panel (23-23-31)
	11	6024 478	Fastener
23	1	2482 755	MEDALLION, Deck Lid (23-19-114)
	1	6022 013	Washer 1 116 000 Nut
24	1	2424 990-1	PANEL, Deck Lower Panel Finish (23-23-28)
	12	6022 997	Washer 12 6023 685 Nut
25	1	2421 448	MOULDING PACKAGE, Deck Lower Panel Filler Door (23-23-23)
	2	6010 093	Clip 2 6024 679 Nut
26	1	2424 988-9	PANEL, Quarter Outside Finish (23-23-85)
	2	6023 682	Screw 2 ---- --- Seal
27	1	2448 428-9	MOULDING PACKAGE, Quarter Panel Lower Rear (23-23-39)
	10	6001 099	Retainer 10 6024 679 Nut
	2	188 973	Screw 4 ---- --- Nut
28	1	2423 740-1	MOULDING, Quarter Panel Wheel Opening (23-23-39)
	16	6024 271	Screw
28A	1	2243 712-3	MOULDING, Quarter Panel Wheel Opening to Sill (23-23-39)
29	1	2421 573-4	MOULDING PACKAGE, Body Side Sill, w/Cap (23-23-2)
	18	6001 605	Retainer
	2	6022 052	Washer 2 ---- --- Nut
30	1	2448 550-1	MOULDING PACKAGE, Door Belt (23-23-32)
	10	6001 497	Retainer
	2	6001 087	Retainer 2 9417 621 Nut

All Packages Include Attaching Parts

Part Type Code is Indicated in Parentheses

EXTERIOR VIEW - CHRYSLER VC2-300K CONVERTIBLE COUPE

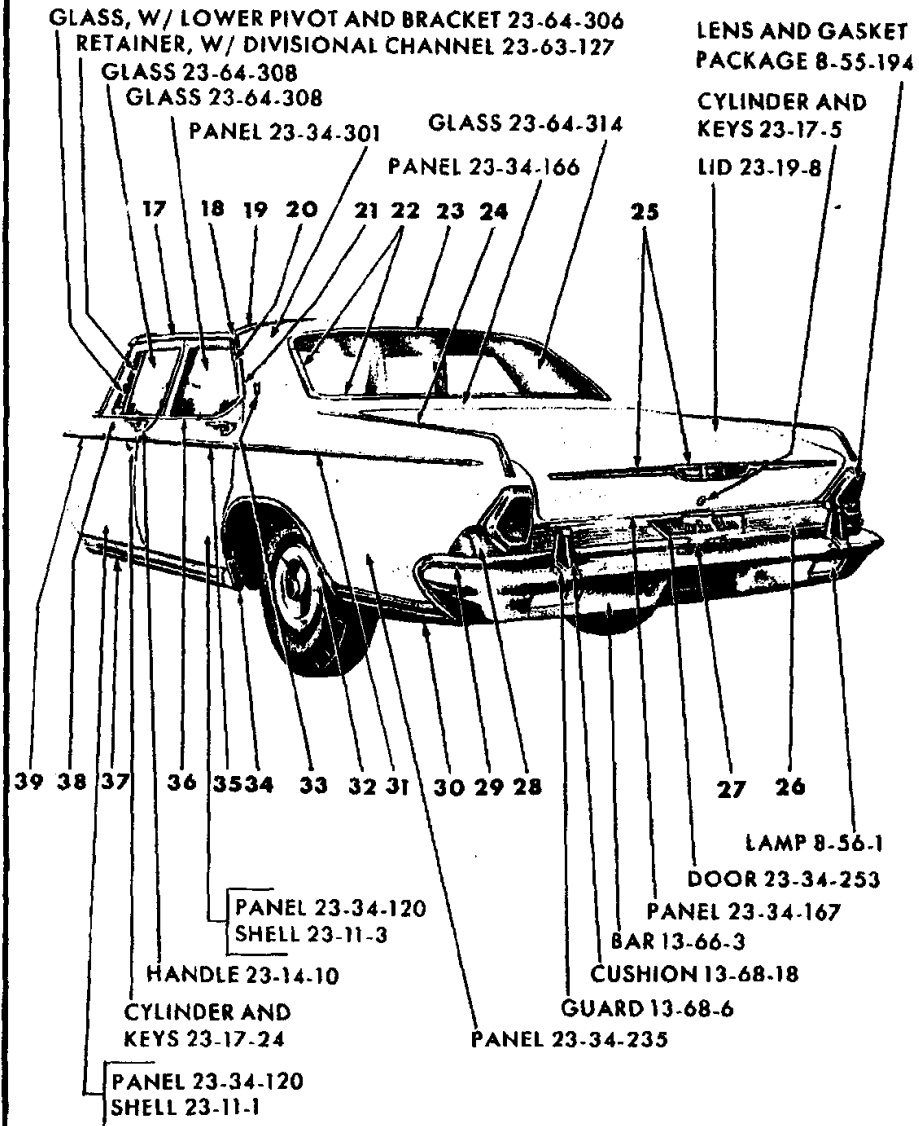
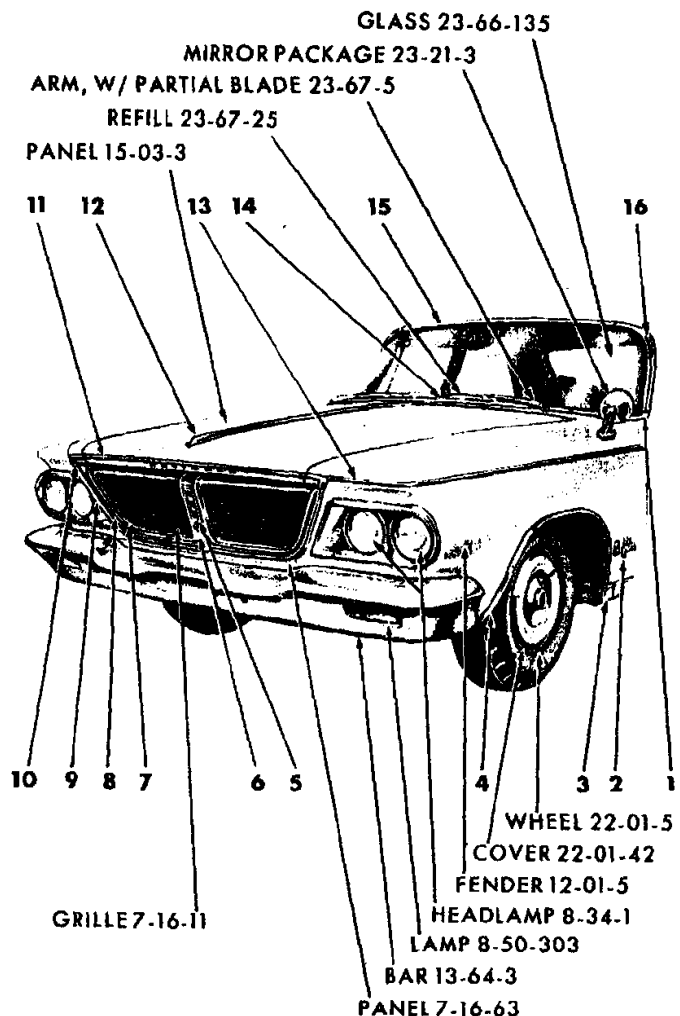

EXTERIOR VIEW - CHRYSLER VC3(H) 4 DOOR SEDAN

19x9924B

REF. NO.	QTY	PART NUMBER	DESCRIPTION	REF. NO.	QTY	PART NUMBER	DESCRIPTION
1	1	2495 896-7	MOULDING, Windshield Outside Finish Lower End (23-23-65)	22	1	2423 092-3	MOULDING, Rear Window Outside Side and Lower (23-23-52)
	2	274 411	Screw	12	6001 084		Retainer and Screw
2	2	2255 082	NAME PLATE, Fender Side, "New" (12-15-21)	23	1	2423 091	MOULDING, Rear Window Outside Upper (23-23-52)
	2	2255 083	"Yorker"	7	6001 084		Retainer and Screw
	10	6000 050	Clip	24	1	2525 560-1	MOULDING PACKAGE, Quarter Panel Peak (23-23-39)
3	1	2495 714-5	MOULDING PACKAGE, Fender Wheel Opening to Sill (12-15-2)	14	6024 656		Washer 14 9411 618 Nut
	2	6023 247	Screw 2 ---- Nut	25	1	2484 405	ORNAMENT and MEDALLION, Deck Lid (23-19-114)
4	1	2445 834-5	MOULDING PACKAGE, Fender Wheel Opening (12-15-2)	8	6023 097		Nut
	16	6023 247	Screw	26	1	2424 990-1	PANEL, Deck Lower Panel Finish (23-23-28)
5	1	2417 999	MEDALLION, Radiator Grille (7-17-1)	12	6022 997		Washer 12 6023 685 Nut
6	1	2445 048	MEDALLION, Radiator Grille, w/Base (7-17-1)	27	1	2421 448	MOULDING PACKAGE, Deck Lower Panel Filler Door (23-23-23)
7	1	2417 754-5	FRAME, Radiator Grille (7-16-36)	2	6000 709		Clip 2 6024 679 Nut
8	1	2276 410	FRAME, Radiator Grille Opening (7-16-36)	28	1	2424 988-9	PANEL, Quarter Outside Finish (23-23-85)
9	1	2495 726	MOULDING PACKAGE, Radiator Grille Opening Frame (7-16-36)	2	----	---	Seal 2 6023 682 Screw
	9	6001 070	Clip	29	1	2448 428-9	MOULDING PACKAGE, Quarter Panel Lower Rear (23-23-39)
	9	6023 284	Nut 9 9415 921 Screw	10	6001 099		Retainer
10	1	2495 730-1	MOULDING PACKAGE, Radiator Grille Opening Frame Corner (7-16-36)	10	6024 679		Nut 4 ---- Nut
	4	9411 618	Nut	30	1	2483 150-1	MOULDING, Quarter Panel Lower Front (23-23-39)
11	1	2495 180	MOULDING PACKAGE, Hood Front (15-25-2)	12	6024 271		Screw
	6	9411 618	Nut	6	6001 430		Retainer 6 ---- Nut
12	1	2495 181	MOULDING PACKAGE, Hood Top (15-25-2)	31	1	2421 567-8	MOULDING PACKAGE, Quarter Panel Lower (23-23-39)
	7	6023 097	Nut	2	6024 679		Nut 2 6000 709 Clip
13	1	2495 712-3	MOULDING PACKAGE, Fender Side (12-15-2)	12	6001 048		Retainer 4 6024 271 Screw
	14	6001 048	Retainer	32	1	2483 714-5	MOULDING, Quarter Panel Wheel Opening (23-23-39)
	6	6001 059	Retainer 6 6024 679 Nut	14	6024 271		Screw
14	1	2084 997	MOULDING PACKAGE, Windshield Outside Finish Lower Center (23-23-65)	33	2	2445 586	MEDALLION, Quarter Outside Panel (23-34-334)
	5	6000 685	Clip	2	6000 050		Clip 2 152 259 Nut
15	1	2495 694	MOULDING PACKAGE, Windshield Outside Finish Upper Center (23-23-65)	34	1	2483 146-7	MOULDING, Body Side Sill to Quarter Panel Wheel Opening (23-23-39)
	5	6000 927	Clip 2 6023 277 Screw	35	1	2421 561-2	MOULDING PACKAGE, Rear Door Lower (23-23-33)
16	1	2216 870-1	MOULDING, Windshield Outside Finish Side (23-23-65)	8	6001 048		Retainer
	8	6023 247	Screw	8	6001 058		Clip 2 446 618 Nut
17	1	2243 740-1	MOULDING, Roof Side Drain Trough Front (23-59-61)	36	1	2421 559-60	MOULDING PACKAGE, Rear Door Belt (23-23-33)
	12	6023 559	Screw w/Washer	12	6001 497		Retainer
	12	2255 633	Clip	37	1	2495 436-7	MOULDING PACKAGE, Body Side Sill (23-23-2)
18	1	2243 744-5	CAP, Roof Side Drain Trough Moulding Joint (23-59-57)	14	6001 546		Retainer 2 6024 288 Screw
19	1	2448 549	MOULDING PACKAGE, Roof Panel Outside Rear (23-23-42)	38	1	2448 552-3	MOULDING PACKAGE, Front Door Belt (23-23-32)
20	1	2424 066-7	MOULDING, Roof Panel Outside Side (23-23-42)	8	6001 497		Retainer
	4	6024 271	Screw and Sealer	2	6001 087		Retainer 2 9417 621 Nut
21	1	2483 588-9	MOULDING, Roof Side Drain Trough Rear (23-59-61)	39	2	2421 558	MOULDING PACKAGE, Front Door Lower (23-23-32)
	4	6024 271	Screw w/Sealer	8	6001 048		Retainer
				8	6001 058		Clip 8 446 618 Nut

All Packages include Attaching Parts

Part Type Code is indicated in Parentheses

EXTERIOR VIEW - CHRYSLER VC3(H) 4 DOOR SEDAN

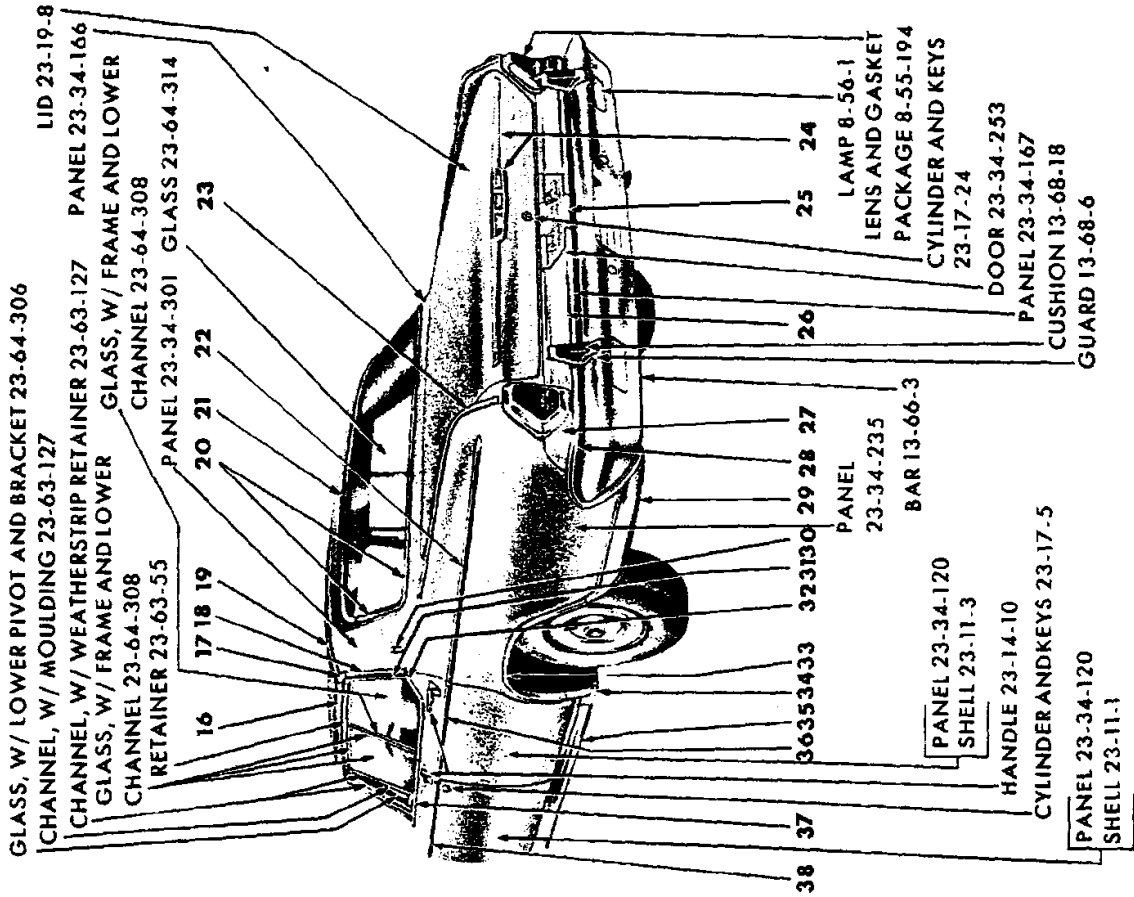

19x99268

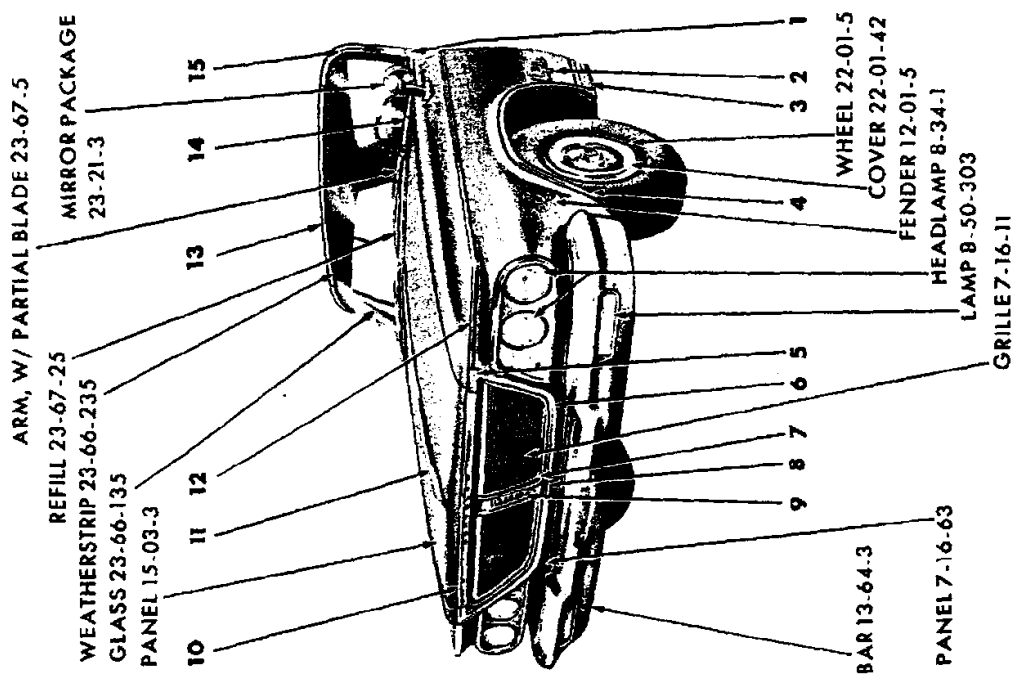

EXTERIOR VIEW - CHRYSLER VC3(H) 4 DOOR HARDTOP

REF. NO.	QTY	PART NUMBER	DESCRIPTION	REF. NO.	QTY	PART NUMBER	DESCRIPTION	
1	1	2495 596-7	MOULDING, Windshield Outside Finish Lower End (23-23-65)	21	1	2423 091	MOULDING, Rear Window Outside Upper (23-23-52)	
	2	274 411	Screw		7	6001 084	Retainer and Screw	
2	2	2255 082	NAME PLATE, Fender Side, "New" (12-15-21)	22	1	2421 567-8	MOULDING PACKAGE, Quarter Panel Lower (23-23-39)	
	2	2255 083	"Yorker"		2	6024 679	Nut 2 6000 709 Clip	
	10	6000 050	Clip		12	6001 048	Retainer 4 6024 271 Screw	
3	1	2495 714-5	MOULDING PACKAGE, Fender Wheel Opening to Sill (12-15-2)	23	1	2525 560-1	MOULDING PACKAGE, Quarter Panel Peak (23-23-39)	
	2	6023 247	Screw 2 ---- Nut		14	6024 656	Washer 14 9411 618 Nut	
4	1	2445 834-5	MOULDING PACKAGE, Fender Wheel Opening (12-15-2)	24	1	2484 405	ORNAMENT and MEDALLION, Deck Lid (23-19-114)	
	16	6023 247	Screw		8	6023 097	Nut	
5	1	2495 730-1	MOULDING PACKAGE, Radiator Grille Corner (7-16-36)	25	1	2421 448	MOULDING PACKAGE, Deck Lower Panel Filler Door (23-23-23)	
	4	9411 618	Nut		2	6010 093	Clip	
6	1	2495 726	MOULDING PACKAGE, Radiator Grille Opening Frame (7-16-36)		2	6024 679	Nut	
	9	6001 070	Clip	26	1	2424 990-1	PANEL, Deck Lower Panel Finish (23-23-28)	
	9	6023 284	Nut 9 9415 921 Screw		12	6022 997	Washer	
7	1	2417 754-5	FRAME, Radiator Grille (7-16-36)		12	6023 685	Nut	
8	1	2276 410	FRAME, Radiator Grille Opening (7-16-36)	27	1	2424 988-9	PANEL, Quarter Outside Finish (23-23-85)	
9	1	2417 999	MEDALLION, Radiator Grille (7-17-1)		2	----	Seal 2 6023 882 Screw	
	1	2445 048	MEDALLION, w/Base, Radiator Grille	28	1	2448 428-9	MOULDING PACKAGE, Quarter Panel Lower Rear (23-23-39)	
	4	6006 264	Nut		10	6001 099	Retainer 4 ---- Nut	
10	1	2495 180	MOULDING PACKAGE, Hood Front (15-25-2)		10	6024 679	Nut 2 188 973 Screw	
	6	9411 618	Nut	29	1	2483 150-1	MOULDING, Quarter Panel Lower Front (23-23-39)	
11	1	2495 181	MOULDING PACKAGE, Hood Top (15-25-2)		12	6024 271	Screw	
	7	6023 097	Nut		6	6001 430	Retainer 6 ---- Nut	
12	1	2495 712-3	MOULDING PACKAGE, Fender Side (12-15-2)	30	2	2445 586	MEDALLION, Quarter Outside Panel (23-34-334)	
	14	6001 048	Retainer		2	6000 050	Clip 2 152 259 Nut	
	6	6001 059	Clip 6 6024 679 Nut	31	1	2424 066-7	MOULDING, Roof Panel Outside Side (23-23-42)	
13	1	2495 694	MOULDING PACKAGE, Windshield Outside Finish Upper Center (23-23-65)		4	6024 271	Screw and Sealer	
	5	6000 927	Clip 2 6023 277 Screw	32	1	2421 559-60	MOULDING PACKAGE, Rear Door Belt (23-23-33)	
14	1	2084 997	MOULDING PACKAGE, Windshield Outside Finish Lower Center (23-23-65)		12	6001 497	Retainer	
	5	6000 685	Clip	33	1	2483 714-5	MOULDING, Quarter Panel Wheel Opening (23-23-39)	
15	1	2216 870-1	MOULDING, Windshield Outside Finish Side (23-23-65)		14	6024 271	Screw	
	8	6023 247	Screw	34	1	2483 146-7	MOULDING, Body Side Sill to Quarter Panel Wheel Opening (23-23-39)	
16	1	2243 740-1	MOULDING, Roof Side Drain Trough Front (23-59-61)		35	1	2495 436-7	MOULDING PACKAGE, Body Side Sill (23-23-2)
	12	2255 633	Clip		14	6001 546	Retainer 2 6024 288 Screw	
	12	6023 559	Screw w/Washer	36	1	2421 561-2	MOULDING PACKAGE, Rear Door Lower (23-23-33)	
17	1	2243 744-5	CAP, Roof Side Drain Trough Moulding Joint (23-59-57)		8	6001 048	Retainer	
	2	446 618	Nut 8 6001 058 Clip	37	1	2448 552-3	MOULDING PACKAGE, Front Door Belt (23-23-32)	
18	1	2483 588-9	MOULDING, Roof Side Drain Trough Rear (23-59-61)		8	6001 497	Retainer	
	4	6024 271	Screw, w/Sealer		2	6001 087	Retainer 2 9417 621 Nut	
19	1	2448 549	MOULDING PACKAGE, Roof Panel Outside Rear (23-23-42)	38	2	2421 558	MOULDING PACKAGE, Front Door Lower (23-23-32)	
	4	6001 455	Clip and Seal		8	6001 048	Retainer	
	4	----	Nut		8	446 618	Nut	
20	1	2423 092-3	MOULDING, Rear Window Outside Side and Lower (23-23-52)		8	6001 058	Clip	
	12	6001 084	Retainer and Screw					

All Packages Include Attaching Parts

Part Type Code is Indicated in Parentheses

EXTERIOR VIEW - CHRYSLER VC3(H) 4 DOOR HARDTOP

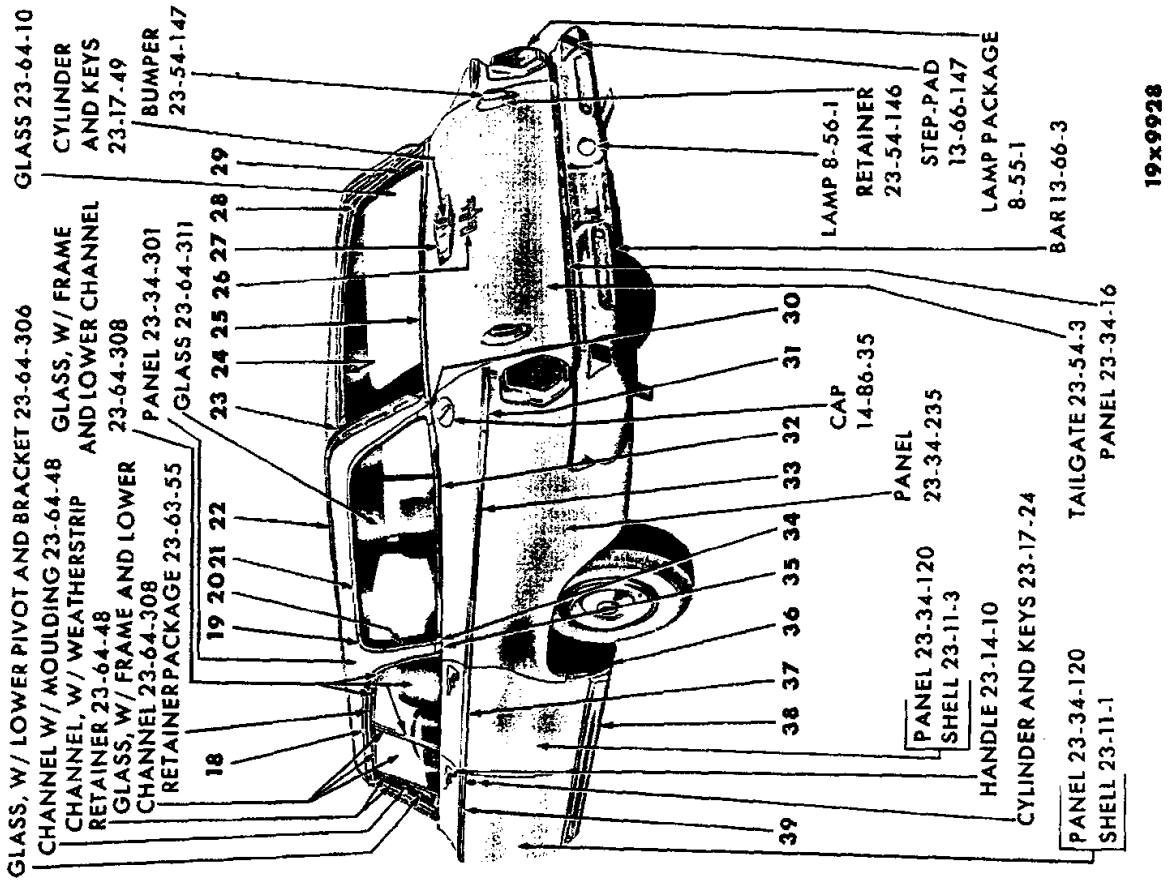

19x9928

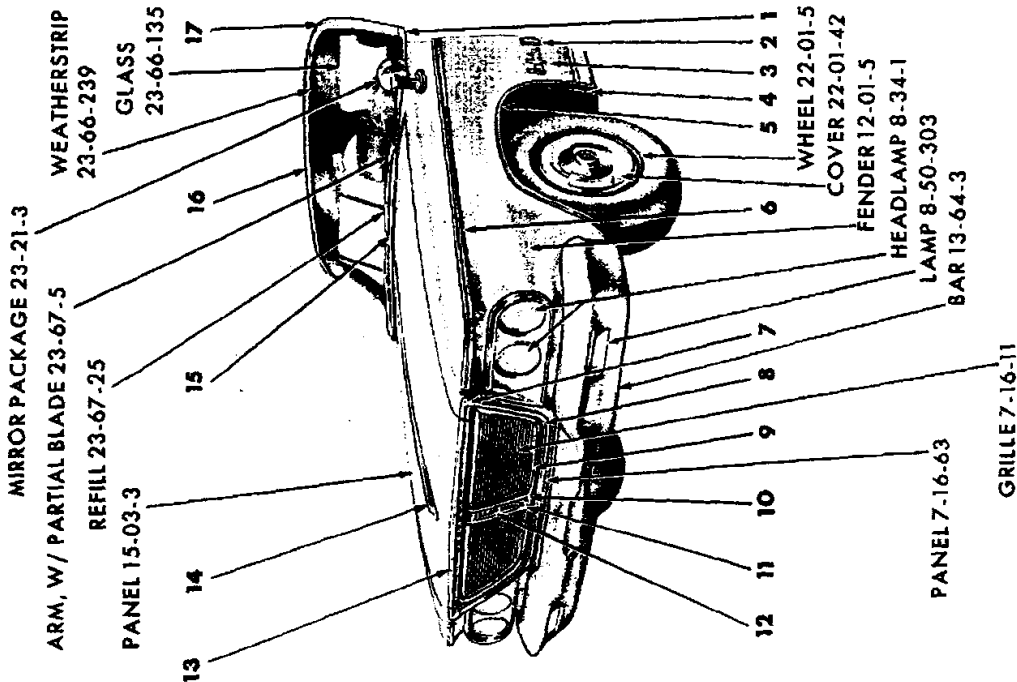

EXTERIOR VIEW - CHRYSLER VC3(H) 4 DOOR HARDTOP STATION WAGON

REF. NO.	QTY	PART NUMBER	DESCRIPTION
1	1	2495 696-7	MOULDING, Windshield Outside Finish Lower End (23-23-65)
	2	274 411	Screw
2	2	2445 586	MEDALLION, Fender Side (12-15-21)
	4	6000 050	Clip
3	2	2255 082	NAME PLATE, Fender Side, "New" (12-15-21)
	2	2255 083	"Yorker"
	10	6000 050	Clip
4	1	2495 714-5	MOULDING PACKAGE, Fender Wheel Opening to Sill (12-15-2)
	2	6023 247	Screw 2 ---- Nut
5	1	2445 834-5	MOULDING PACKAGE, Fender Wheel Opening (12-15-2)
	16	6023 247	Screw
6	1	2495 706-7	MOULDING PACKAGE, Fender Side (12-15-2)
	10	6001 605	Retainer 12 6024 679 Nut
	12	6001 462	Retainer 4 6001 557 Clip
7	1	2495 730-1	MOULDING PACKAGE, Radiator Grille Opening Corner (7-16-36)
	4	6025 434	Nut
8	1	2495 726	MOULDING PACKAGE, Radiator Grille Opening Frame (7-16-36)
	9	6001 070	Clip
	9	6023 284	Nut 9 9415 921 Screw
9	1	2417 754-5	FRAME, Radiator Grille (7-16-36)
10	1	2276 410	FRAME, Radiator Grille Opening (7-16-36)
11	1	2445 048	MEDALLION, Radiator Grille, w/Base (7-17-1)
12	1	2417 999	MEDALLION, Radiator Grille (7-17-1)
13	1	2495 180	MOULDING PACKAGE, Hood Front (15-25-2)
	6	9411 618	Nut
14	1	2495 181	MOULDING PACKAGE, Hood Top (15-25-2)
	7	6023 097	Nut
15	1	2084 997	MOULDING PACKAGE, Windshield Outside Finish Lower Center (23-23-65)
	5	6000 685	Clip
16	1	2299 418	MOULDING PACKAGE, Windshield Outside Finish Upper (23-23-65)
	5	6000 927	Clip 2 9414 754 Screw
17	1	2480 458-9	MOULDING, Windshield Outside Finish Side Upper and Lower (23-23-65)
	8	6023 247	Screw
18	1	2093 648-9	MOULDING, Roof Side Drain Trough (23-59-61)
19	1	2094 016-7	CAP and RETAINER, Quarter Window Outside Front Upper (23-23-74)
20	1	2094 018-9	MOULDING, Quarter Window Front Outside Finish (23-23-73)
21	1	1961 212-3	MOULDING, Quarter Window Upper Outside Finish (23-23-73)
22	2	2196 252	MOULDING PACKAGE, Roof Top, used w/Rear Pillar Assist Handle (23-23-42)
	20	6006 301	Clip

REF. NO.	QTY	PART NUMBER	DESCRIPTION
22	2	2196 253	MOULDING PACKAGE, Roof Panel Outside Finish, used w/o Assist Handle (23-23-42)
	28	6006 301	Clip
23	2	2196 839	HANDLE PACKAGE, Roof Panel Rear Pillar Assist (23-36-123)
	8	6006 035	Nut 2 681 135 Bolt
24	1	2196 466	MOULDING PACKAGE, Roof Peak Tailgate Opening (23-23-60)
	7	6006 451	Clip
25	1	2196 460	MOULDING PACKAGE, Tailgate Outside Finish Belt (23-23-61)
	2	6006 441	Clip 2 151 306 Screw
26	1	2255 082	NAME PLATE "New", Tailgate Outside Panel (23-54-11)
	1	2255 083	"Yorker"
	5	6000 604	Clip
27	1	2188 389	ORNAMENT, Tailgate Outside Panel (23-54-11)
28	1	2196 464-5	CAP PACKAGE, Roof Rear Tailgate Opening Moulding (23-23-60)
	2	6006 451	Clip
29	1	2196 462-3	MOULDING PACKAGE, Rear Pillar Tailgate Opening (23-23-60)
	4	6006 451	Clip
30	1	2196 816-7	CAP PACKAGE, Quarter Window Outside Finish Lower Rear (23-23-74)
	2	125 978	Screw
31	1	2495 482-3	MOULDING PACKAGE, Quarter Panel Rear (23-23-39)
	6	6001 099	Clip
32	1	1961 214-5	MOULDING, Quarter Window Lower Outside Finish (23-23-73)
33	1	2495 488-9	MOULDING PACKAGE, Quarter Panel Front (23-23-39)
	14	6001 547	Clip 2 274 411 Screw
34	2	1961 210	CAP, Quarter Window Outside Finish Lower Front Moulding (23-23-74)
35	1	2299 430-1	MOULDING PACKAGE, Quarter Panel Belt (23-23-39)
	2	6024 401	Screw
36	1	2483 600-1	STONE DEFLECTOR, Quarter Outside Wheel Opening (23-34-240)
	4	6024 271	Screw
37	1	2495 484-5	MOULDING PACKAGE, Rear Door (23-23-39)
	10	6001 505	Retainer
	2	6001 516	Clip 2 9417 621 Nut
38	2	2495 924	MOULDING PACKAGE, Body Side Sill (23-23-2)
	14	6001 546	Retainer
39	2	2495 449	MOULDING PACKAGE, Front Door (23-23-39)
	4	6001 544	Clip
	8	6001 049	Retainer
	4	9417 621	Nut

All Packages include Attaching Parts

Part Type Code is indicated in Parentheses

EXTERIOR VIEW - CHRYSLER VC3(H) 4 DOOR HARDTOP STATION WAGON

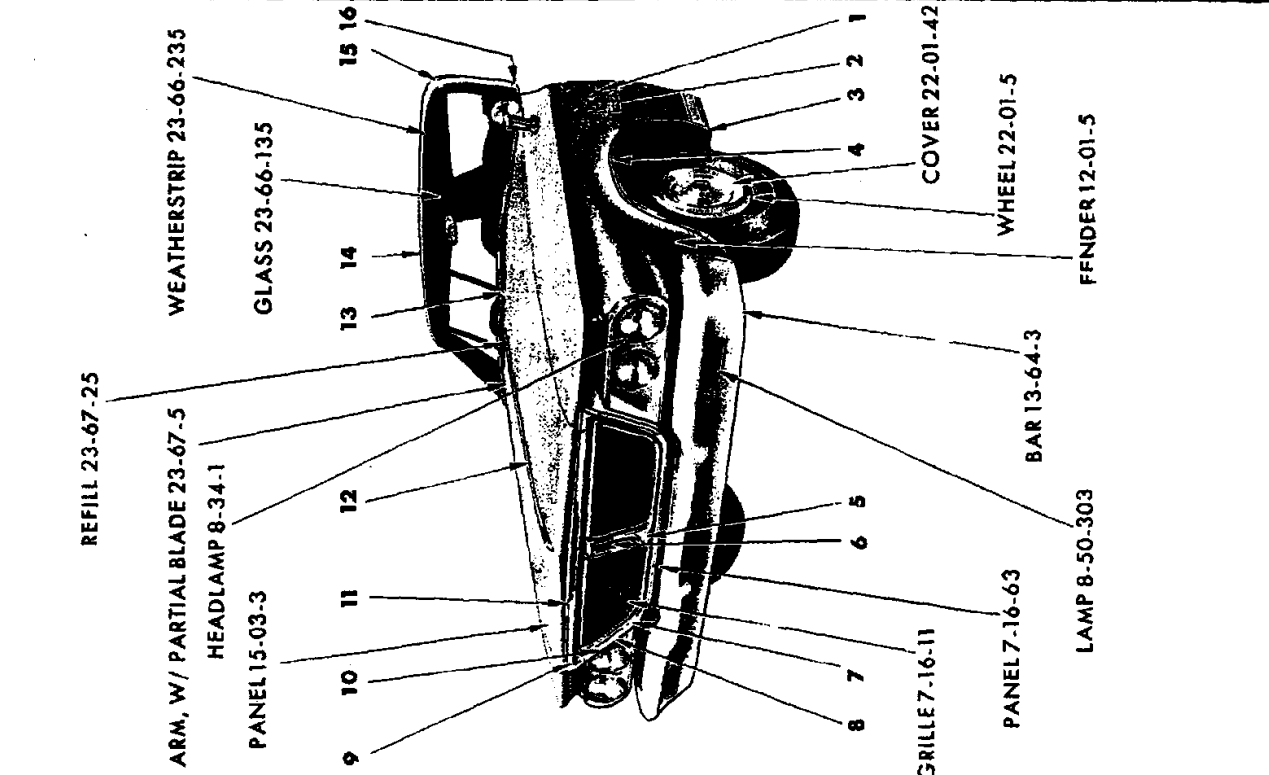
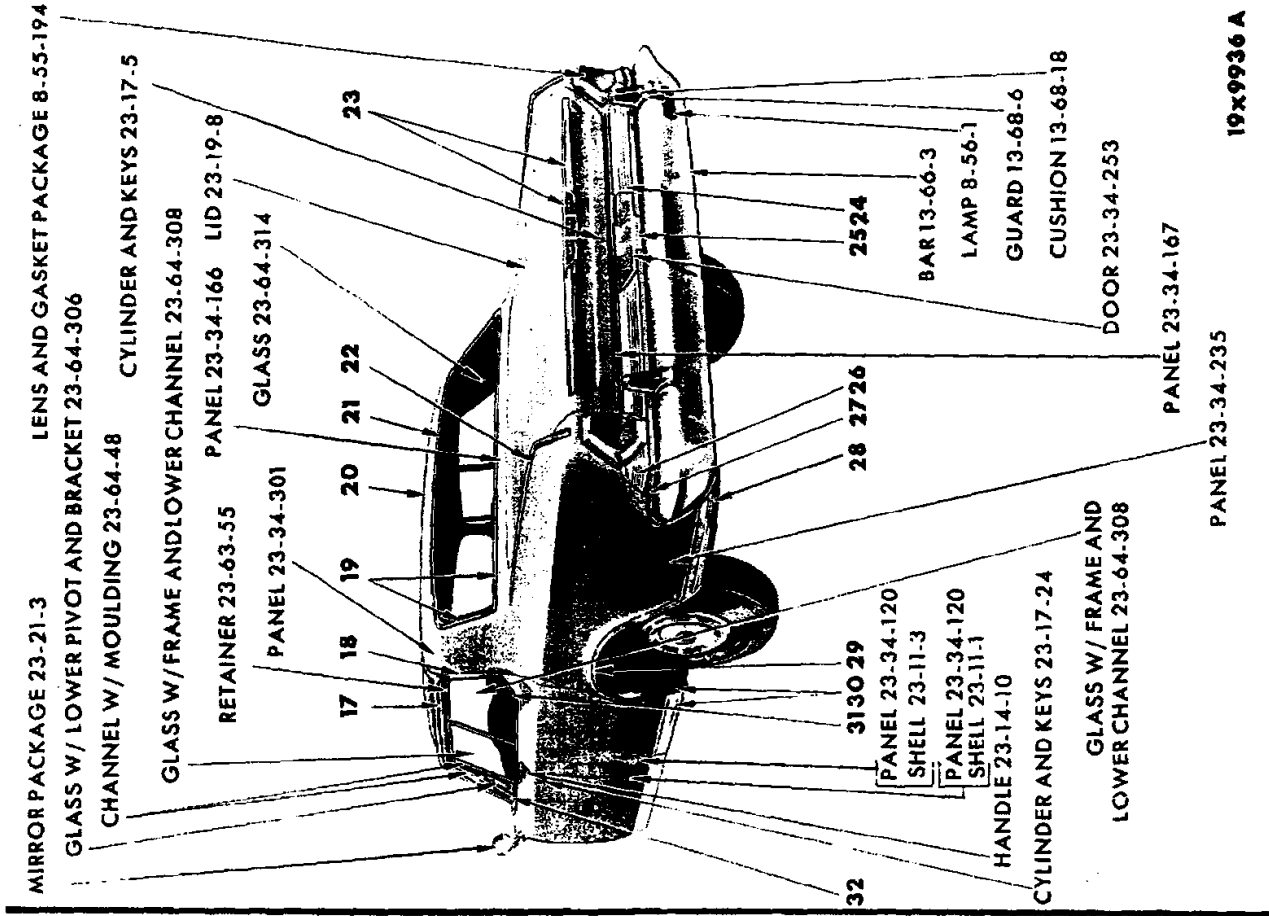

EXTERIOR VIEW - CHRYSLER SALON VC3(H) 4 DOOR HARDTOP

REF. NO.	QTY	PART NUMBER	DESCRIPTION
1	2	2255 082	NAME PLATE, Fender Side, "New" (12-15-21)
	2	2255 083	"Yorker"
	10	6000 050	Clip
2	2	2445 042	NAME LETTER, Fender Side, "S" (12-15-21)
	2	2445 043	"A"
	2	2445 044	"L"
	2	2445 045	"O"
	2	2445 046	"N"
	10	6000 050	Clip
3	1	2495 714-5	MOULDING PACKAGE, Fender Wheel Opening to Sill (12-15-2)
	2	6023 247	Screw 2 ---- Nut
4	1	2445 834-5	MOULDING PACKAGE, Fender Wheel Opening (12-15-2)
	16	6023 247	Screw
5	1	2445 048	MEDALLION, Radiator Grille, w/Base (7-17-1)
6	1	2417 999	MEDALLION, Radiator Grille (7-17-1)
7	1	2417 754-5	FRAME, Radiator Grille (7-16-36)
8	1	2276 410	FRAME, Radiator Grille Opening (7-16-36)
9	1	2495 730-1	MOULDING PACKAGE, Radiator Grille Opening Frame Corner (7-16-36)
	4	9411 618	Nut
10	1	2495 726	MOULDING PACKAGE, Radiator Grille Opening Frame (7-16-36)
	9	6001 070	Clip
	9	6023 234	Nut 9 9415 921 Screw
11	1	2495 180	MOULDING PACKAGE, Hood Front (15-25-2)
	6	9411 618	Nut
12	1	2495 181	MOULDING PACKAGE, Hood Top (15-25-2)
	7	6023 097	Nut
13	1	2084 997	MOULDING PACKAGE, Windshield Outside Lower Center (23-23-65)
	5	6000 685	Clip
14	1	2495 694	MOULDING PACKAGE, Windshield Outside Finish Upper Center (23-23-65)
	5	6000 927	Clip 2 6023 277 Screw
15	1	2216 870-1	MOULDING, Windshield Outside Finish Side (23-23-65)
	8	6023 247	Screw
16	1	2495 696-7	MOULDING, Windshield Outside Finish Lower End (23-23-65)
	2	274 411	Screw
17	1	2480 000-1	MOULDING, Roof Side Drain Trough (23-59-61)
	20	6023 559	Screw w/Washer
	12	2480 004	Clip

REF. NO.	QTY	PART NUMBER	DESCRIPTION
18	1	2424 066-7	MOULDING, Roof Panel Outside Side (23-23-42)
	4	6024 271	Screw and Sealer
19	1	2423 092-3	MOULDING, Rear Window Outside Side and Lower (23-23-52)
	12	6001 084	Retainer and Screw
20	1	2448 549	MOULDING PACKAGE, Roof Panel Outside Rear (23-23-42)
	4	6001 455	Clip and Seal
	4	-----	Nut
21	1	2423 091	MOULDING, Rear Window Outside Upper (23-23-52)
	7	6001 084	Retainer and Screw
22	1	2525 560-1	MOULDING PACKAGE, Quarter Panel Peak (23-23-39)
	14	6024 656	Washer 14 9411 618 Nut
23	1	2484 405	ORNAMENT and MEDALLION, Deck Lid (23-19-114)
	8	6023 097	Nut
24	1	2424 990-1	PANEL, Deck Lower Panel Finish (23-23-28)
	12	6022 997	Washer 12 6023 685 Nut
25	1	2421 448	MOULDING PACKAGE, Deck Lower Panel Filler Door (23-23-23)
	2	6000 709	Clip 2 6024 679 Nut
26	1	2424 988-9	PANEL, Quarter Outside Finish (23-23-85)
	2	-----	Seal 2 6023 682 Screw
27	1	2448 428-9	MOULDING PACKAGE, Quarter Panel Lower Rear (23-23-39)
	10	6001 099	Retainer 4 ---- Nut
	10	6024 679	Nut 2 188 973 Screw
28	1	2483 150-1	MOULDING, Quarter Panel Lower Front (23-23-39)
	12	6024 271	Screw 6 ---- Nut
	6	6001 430	Retainer
29	1	2483 714-5	MOULDING, Quarter Panel Wheelhouse (23-23-39)
	14	6024 271	Screw
30	1	2495 436-7	MOULDING PACKAGE, Body Side Sill (23-23-2)
	14	6001 546	Retainer
	2	6024 288	Screw
31	1	2421 559-60	MOULDING PACKAGE, Rear Door Belt (23-23-33)
	12	6001 497	Retainer
32	1	2448 552-3	MOULDING PACKAGE, Front Door Belt (23-23-32)
	8	6001 497	Retainer
	2	6001 087	Retainer
	2	9417 621	Nut

All Packages Include Attaching Parts

Part Type Code is Indicated in Parentheses

EXTERIOR VIEW - CHRYSLER SALON VC3(H) 4 DOOR HARDTOP

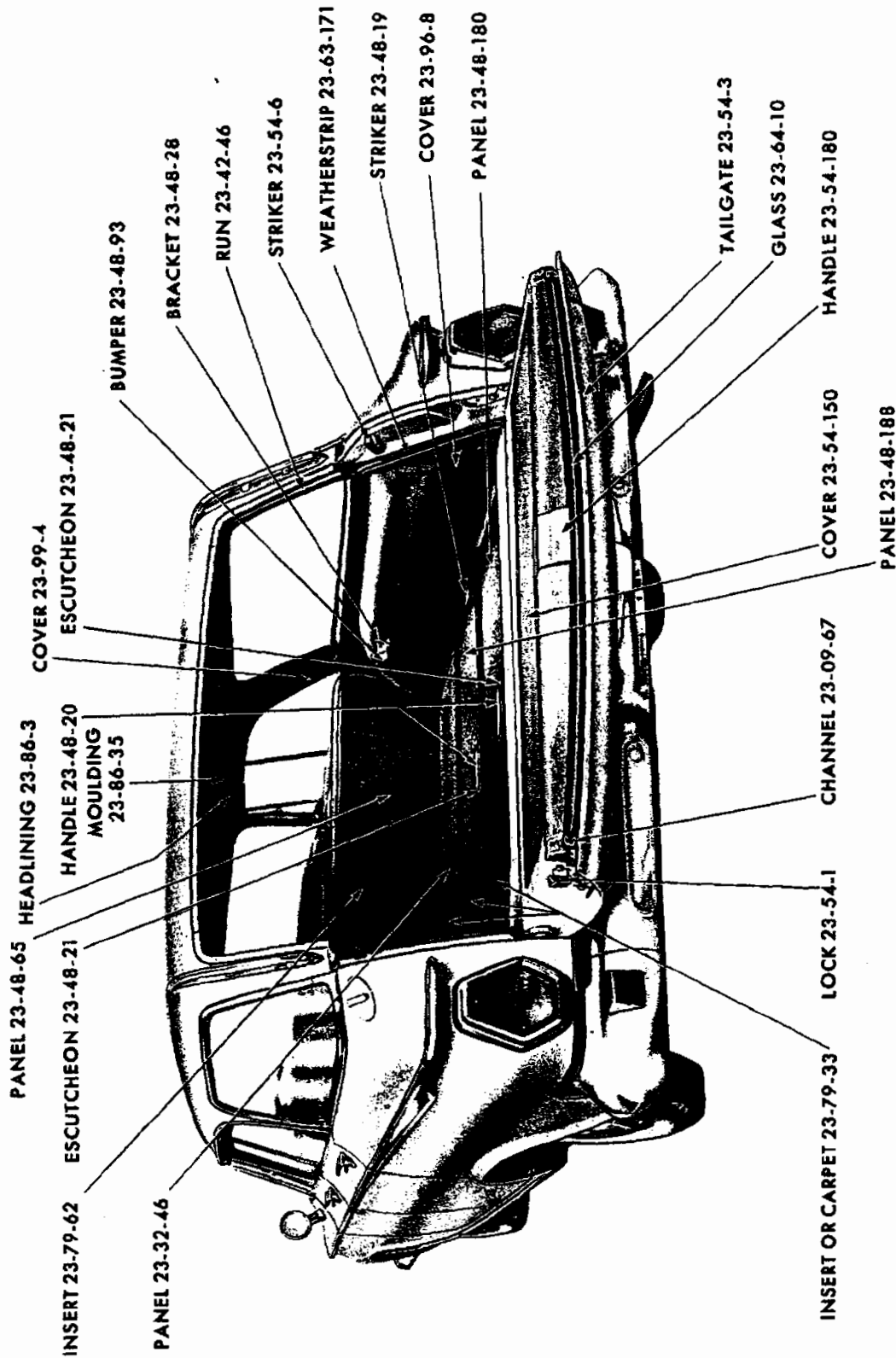

19x9898

REAR INTERIOR VIEW - CHRYSLER VCI-L STATION WAGON (3 SEATER)

