

GROUP 17
SPRINGS AND SHOCK ABSORBERS

CONTENTS

	Page		Page
Front Shock Absorber and/or Bushing.....	5	Rear Spring Interliners.....	3
Measuring Rear Spring Height.....	2	Rear Spring Front Pivot Bushing Replacement.....	4
Rear Shock Absorber Replacement.....	6	Service Diagnosis.....	6
Rear Springs.....	2	Specifications.....	1

SPECIFICATIONS

SPRINGS

Model	TC-1	TC-2	TC-3	TY-1
Type		Semi-Elliptic		
No. of Leaves				
Sedans (all).....	6	6	7	6
Hardtops (all).....	6	6	7	6
Convertibles	6	6	7	6
Town and Country Wagon.....	7	—	7	—
Width (inches).....		2.50		
Length (inches).....	60	60	60	60
Pivot (front).....		Rubber Bushing		
Shackle (rear).....	Side Strapped with Rubber Bushed Bolts			

SHOCK ABSORBERS

Type..... Oriflow, Double Acting Hydraulic

TORQUE REFERENCE

	Foot-Pounds
Rear Spring Front Pivot Bolt Nut.....	125
Rear Spring Shackle Nuts.....	40
Rear Spring "U" Bolt Nuts.....	50
Shock Absorbers Mounting Nut (rear).....	60
(Front—Upper)	25
(Front—Lower)	55
Shock Absorbers Stud Nut—Lower.....	70
Upper	60

GROUP 17

SPRINGS AND SHOCK ABSORBERS

It is important that spring "U" bolts be inspected at regular intervals and kept tight to prevent spring breakage. Tighten the spring "U" bolt nuts 50 foot-pounds torque. The spring shackles should be inspected occasionally to make sure they are tight, but not binding. Tighten to 40 foot-pounds torque. No

lubrication of any kind should be used on the rear springs or rubber bushings.

When measuring the rear spring heights, the vehicle should be placed on a level floor, have the correct front suspension height, the correct tire pressures, no passenger or luggage compartment load and a full tank of fuel.

SERVICE PROCEDURES

1. MEASURING REAR SPRING HEIGHT

(1) Jounce the vehicle several times (front bumper first). Release the bumpers at the same point in each cycle.

(2) Measure the shortest distance from the highest point on the underside of the rear axle bumper strap (at rear of the bumper) to the top of the axle housing.

(3) Measure both the right and left sides.

If these measurements vary by more than $\frac{3}{4}$ inch, it is an indication that one of the rear springs may need replacing. It is normal for rear springs to show

some reverse arch, even with no load, so appearance alone should not be the reason for spring replacement.

Springs may "bottom" under abnormal loading conditions, particularly when road dips and railroad crossings are encountered at relatively high speeds.

2. REAR SPRING (Fig. 1)

Removal

(1) With the vehicle body frame supported on the floor stands and jack pressure under the axle housing,

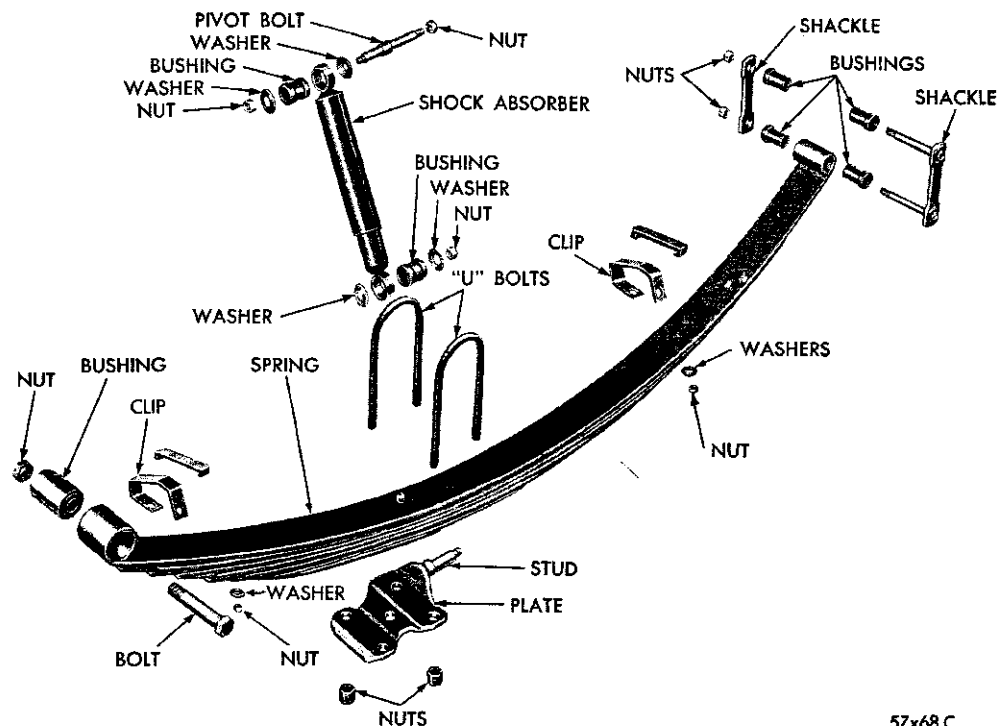

Fig. 1—Rear Springs and Shackles (Disassembled View)



Fig. 2—Rear Spring Rear Shackle

disconnect the shock absorber.

(2) Lower the jack until it supports only the weight of the axle housing and remove the rear spring rear shackle (Fig. 2).

(3) Loosen the rear spring pivot bolt nut. The nut should be backed off until it is retained on the pivot bolt by two or three threads.

(4) Using a pry bar between the pivot bolt nut and the body frame, force the pivot bolt outward until the nut contacts the spring mounting bracket.

(5) Remove the pivot bolt nut and using a suitable tool, force the pivot bolt out of the spring.

(6) Remove the spring "U" bolts and the spring.

Installation

(1) Position the springs in their respective front hangers (Fig. 3) and install the pivot bolts and nuts (**finger tight only**).

(2) Install the spring shackles and nuts.

(3) Install the spring "U" bolts and nuts.

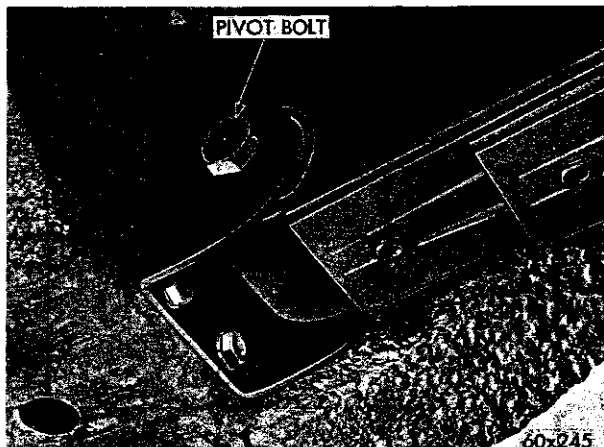

Fig. 3—Rear Spring Front Hanger

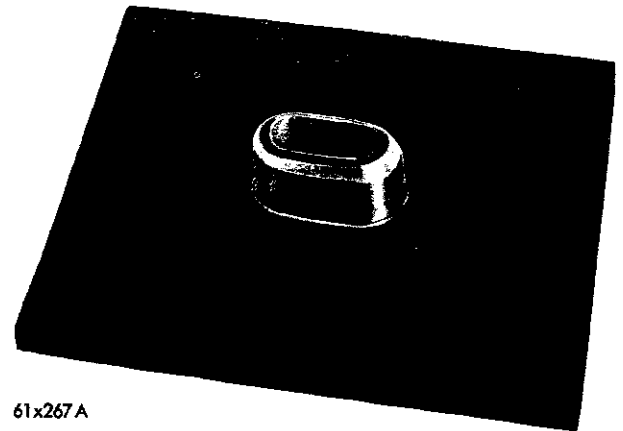

Fig. 4—Rear Spring Front Interliner

(4) Tighten the spring U-bolt nuts 50 foot-pounds torque and shackle bolt nuts 40 foot-pounds torque.

(5) Connect the shock absorbers.

(6) Remove the vehicle floor stands and with the vehicle weight on the wheels, tighten the front pivot bolt to 125 foot-pounds torque.

(7) **The bushings and shackles should not be lubricated at any time.** Measure the vehicle curb height whenever a rear spring or shackle has been replaced.

3. REAR SPRING INTERLINERS (Figs. 4 and 5)

Removal

(1) Raise the rear of the vehicle until the shock absorbers are fully extended.

(2) Remove the alignment clips from the spring.

(3) Separate the spring leaves (Fig. 6) and remove the interliners.

Installation

(1) With the leaves separated, **be sure the spring leaf area where the interliner makes contact, is clean**

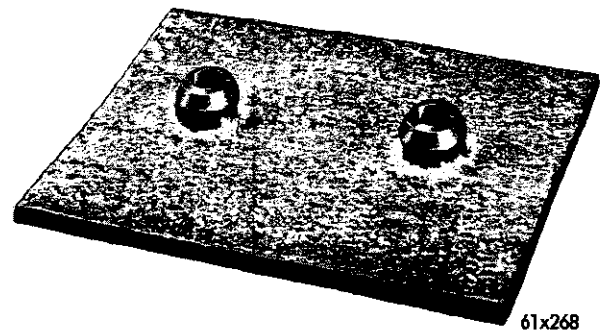
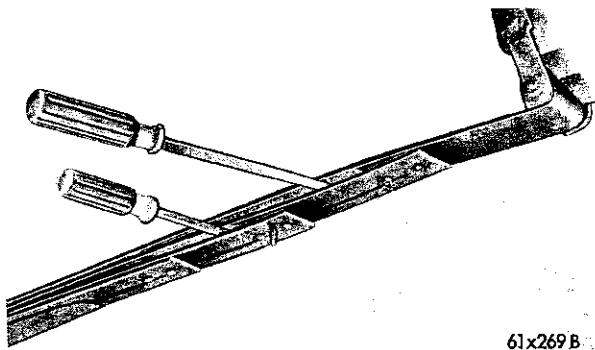
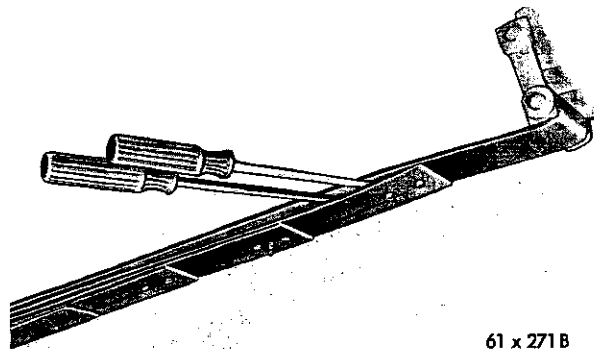

Fig. 5—Rear Spring Rear Interliner



61x269 B

Fig. 6—Separating the Spring Leaves



61 x 271 B

Fig. 8—Installing the Interliner Fastener

and smooth.

(2) Insert the interliner between the spring leaves (Fig. 7) until the fasteners are aligned with the holes.

(3) Force the fastener into the hole in the spring leaf (Fig. 8).

(4) Position the aligning clip (Fig. 9) and tighten the retainer nut. **Do not lubricate rear springs.** The interliners act as the friction control and receive no lubrication.

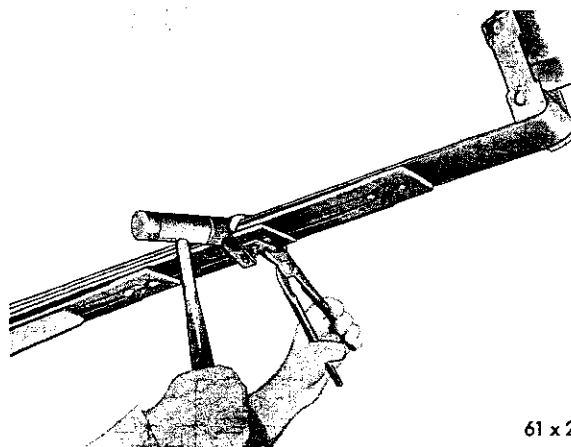

61 x 272 B

Fig. 9—Positioning the Aligning Clip

4. REAR SPRING FRONT PIVOT BUSHING REPLACEMENT

Removal of the old bushing and installation of the new bushing is performed in one operation, using Tool C-3709 (Fig. 10).

(1) On bolt SP-3178, position the bearing washer SP-92, thrust bearing SP-332, bushing adaptor SP-3179 (flat side of adapter next to the washer), spring leaf bushing and remover adapter SP-3180.

(2) Insert bolt SP-3178 through the bushing to be removed.

(3) Install adapter SP3242 on bolt SP-3178. The slot in adaptor SP-3242 should be visible to aid in

correct positioning of the bushing as it is being installed.

(4) Tighten bolt SP-3178 to remove the old bushing and install the new bushing. Remove the tool after the new bushing has been correctly positioned.

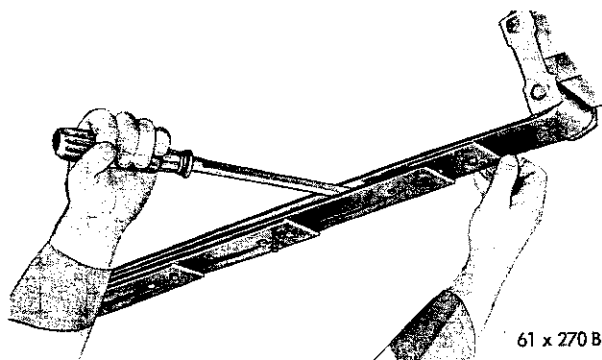

61 x 270 B

Fig. 7—Positioning the Interliner

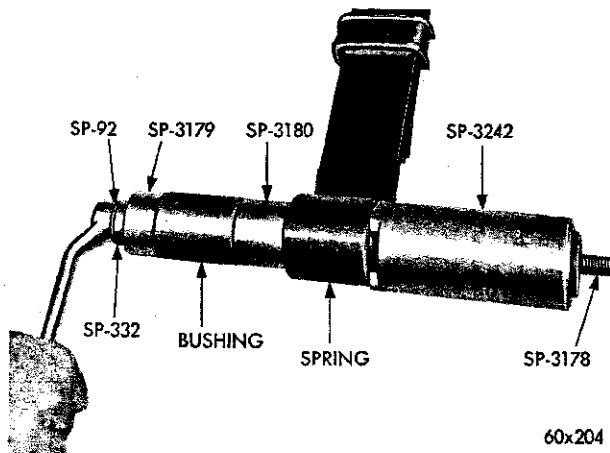

60x204

Fig. 10—Replacing the Spring Leaf Bushing

SHOCK ABSORBERS

The oriflow shock absorber cannot be refilled or disassembled. When servicing is required, the shock absorber must be removed and a new unit installed. **Shock absorbers should only be replaced if they have lost their resistance, are damaged, or if they drip oil. Evidence of slight oil moisture on outside of shock absorber is not cause to replace shock absorber.**

5. FRONT SHOCK ABSORBER AND/OR BUSHING

Removal

(1) Refer to Figure 11 and disconnect the upper end of the shock absorber piston rod.

(2) Compress the shock absorber by pushing the rod through the shock absorber support.

(3) Remove the lower mounting bolt and remove the shock absorber.

(4) If the upper bushing appears worn, damaged or deteriorated remove it by first pressing out the inner stud sleeve, then prying-out or cutting-out the rubber bushing. (This bushing takes some permanent set so that once removed it should be replaced.)

(5) If the lower bushing is to be replaced, remove it from the shock absorber, using Tool C-3553 to press on the **outer** sleeve of the bushing, (Fig. 12). (Pressing on the inner sleeve will not remove the outer sleeve from the shock absorber).

Testing and Bleeding the Shock Absorber

Hold the shock absorber in an upright position with

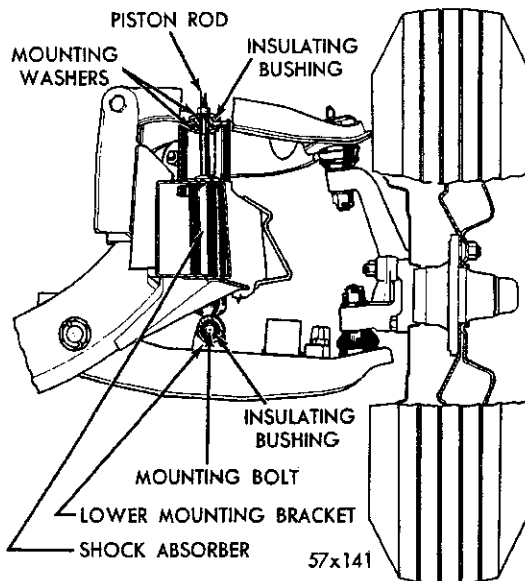

Fig. 11—Front Shock Absorber (Typical Installation)

the dust shield or piston rod section upward. Extend the shock absorber to the maximum length and turn it upside down. Compress the shock absorber. Repeat this procedure to make sure all air is removed from the unit. Do not extend shock absorber when it is in the upside down or in a horizontal position, otherwise air will enter the cylinder tube.

A steady resistance should be felt when the shock absorber is extended or compressed. If no resistance is felt, replace the shock absorber.

Installation

(1) To aid the installation of the upper bushing, dip the bushing in water, start it into the frame opening with a twisting motion, then press or tap it into place. When installed properly, the groove in the bushing will index with the opening in the shock absorber tower.

(2) Install the steel sleeve in the bushing.

(3) Using Tool C-3553, press the lower bushing into the shock absorber eye until it is centered. **Always press against the outer steel sleeve to avoid damage to the assembly.**

(4) Bleed the shock absorber then compress to its shortest length.

(5) Install the lower cup washer (concave side up) on the rod and into position.

(6) Hold the shock absorber in the installed position in the frame. Slide the upper cup washer (concave side down) over piston rod and down onto the bushing. Install the nut finger tight.

(7) Position the lower end of the shock absorber

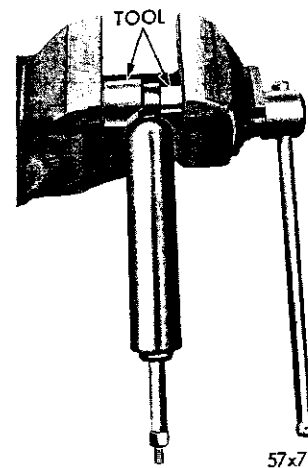

Fig. 12—Replacing the Shock Absorber Lower Bushing

17-6 SPRINGS AND SHOCK ABSORBERS

in the mounting bracket on the lower control arm, then install retaining bolt, lockwasher, and nut. Tighten to 55 foot-pounds torque. While holding the piston rod, tighten the piston rod nut to 25 foot-pounds torque after the upper and lower washers bottom against the core sleeve.

6. REAR SHOCK ABSORBER REPLACEMENT

(1) Remove the nuts and washers attaching the

shock absorber to the mounting studs.

(2) Remove the shock absorber from the studs.

(3) Inspect the bushing for deterioration, damage, or wear. Install new bushings if necessary. Test and bleed the shock absorber, as outlined in Paragraph 5.

(4) Position the shock absorber on the mounting studs and install the remaining cupped washers and nuts. Tighten the upper and lower stud nuts to 60 foot-pounds torque.

SERVICE DIAGNOSIS

Condition	Possible Causes	Corrections
7. Spring Sags or Bottoms	(a) Springs sagged or taken a set.	(a) Replace the spring.
	(b) Broken, bent or weak spring leaves.	(b) Replace the spring main leaf, or spring as necessary.
8. Spring Noise	(a) Loose "U" bolts.	(a) Tighten the "U" bolt nuts 50 foot-pounds torque.
	(b) Loose or worn shackle bushings.	(b) Replace the bushings and tighten shackle bolt nuts 40 foot-pounds torque.
9. Spring Breakage	(c) Worn or missing interliners.	(c) Install new interliners.
	(a) Loose "U" bolts.	(a) Tighten the "U" bolt nuts 50 foot-pounds torque.
	(b) Shock absorber inoperative.	(b) Replace the spring and the shock absorber.
10. Strut Noise Cracking or Grunting Noise at Rear End of Imperial Models	(a) Loose strut bushing bolt nut.	(a) Tighten the strut bushing bolt nut to 65 foot-pounds torque.
	(b) Faulty strut bushing.	(b) Install new bushing. Tighten bushing bolt nut to 65 foot-pounds torque.
