

**GROUP 2
FRONT SUSPENSION**

CONTENTS

	Page		Page
Front Suspension Alignment.....	4	Service Diagnosis.....	12
Front Suspension Height Adjustment.....	3	Steering Knuckles.....	11
Front Wheel Bearing Adjustment.....	3	Steering Linkage.....	12
Lower Ball Joints.....	6	Sway Bar.....	12
Lower Control Arm and Shaft.....	8	Torsion Bars.....	5
Lower Control Arm Strut.....	7	Upper Ball Joints.....	7
Preparation for Measuring Front End Alignment.....	2	Upper Control Arm.....	9

SPECIFICATIONS

	TC-1, TC-2, TC-3	TY-1
CAMBER		
Left.....	+ ¼° to + ¾° (Preferred + ½°)	
Right.....	0° to + ½° (Preferred + ¼°)	
CASTER		
Manual Steering.....	0° to - 1°	
Power Steering.....	+ ¼° to + 1 ¼°	
HEIGHT		
All models except Town & Country and C-300J (High Performance Models).....	2 inches ± ⅛ inch	
Town and Country Models.....	2 ¾ inches ± ⅛ inch	
TC-2—C-300J (High Performance).....	1 ¾ inches ± ⅛ inch	
Side to Side Difference (Maximum).....	⅛ inch	
STEERING AXIS INCLINATION.....	5 ½° to 7 ½°	
TOE-IN.....	¾ inch to ½ inch (Preferred ⅛ inch)	
TOE-OUT ON TURNS.....	21 ½° when Inner Wheel is 20°	
THREAD		
Front (inches).....	60.9	61.7
Rear (inches).....	59.7	62.2
WHEEL BASE (inches).....	122	129

TORQUE REFERENCE

	Foot-Pounds	Inch-Pounds
BALL JOINT IN CONTROL ARMS (TC-1, TC-2, TC-3).....	125 (min.)	
JOINTS IN CONTROL ARM (TY-1).....	150 (min.)	
LOWER BALL JOINT STUD NUT.....	135	
UPPER BALL JOINT STUD NUT ⅙ (TC-1, TC-2) (TC-3).....	100	
⅝ (TY-1).....	135	

2-2 FRONT SUSPENSION

TORQUE REFERENCE— (Continued)

	Foot-Pounds	Inch-Pounds
LOWER CONTROL ARM		
Bumper Nut.....		200
Shaft Nut—Outer $\frac{3}{4}$ (TC-1, TC-2) (TC-3).....	180	
$\frac{7}{8}$ (TY-1).....	200	
Inner $\frac{5}{8}$	100	
Strut Bolt Nut.....	100	
Strut Bushing Nut.....	40	
UPPER CONTROL ARM		
Bumper Nut.....		200
Support Bracket Cam Bolt Nut.....	65	
SWAY ELIMINATOR SHAFT		
Cushion Retainer Bolt Nub.....	35	
Frame Bracket Screws.....		150
Link Nut.....		100
FRONT SHOCK ABSORBERS		
Upper Mounting Nut.....	25	
Lower Mounting Nut.....	55	
STEERING KNUCKLE TO STEERING KNUCKLE ARM NUT.....	80	
STEERING KNUCKLE TO BRACKET SUPPORT BOLT.....	55	

GROUP 2

FRONT SUSPENSION

All ball joints and the torsion bars at the front of the rear anchors are effectively sealed against road splash by tightly fitted balloon type flexible seals. The ball joints are of the semi-permanent lubricated type and should not under normal operating conditions require lubrication with the special lubricant before 32,000 miles.

Lower ball joints should not be replaced for looseness if the axial end play (Up and Down movement) is under .050". Looseness of this nature is not detrimental and will not affect front end alignment.

CAUTION: When lubrication of the ball joints is necessary, use a hand type lubrication gun only, filled with the specified lubricant. Use of pressure type lubrication equipment may damage the balloon type seals.

NOTE: All service replacement ball joints are equipped with a "Knock-Off" type lubrication fitting. After the ball joint has been lubricated with the

specified lubricant, knock off that portion of the lubrication fitting over which the grease gun was installed. A special ball check is installed in the remaining portion of the fitting to prevent foreign materials from passing through the fitting.

The tie rod end seals and protectors should be inspected at all oil change periods. Damaged seals necessitate replacement of the tie rod end assembly. The tie rod end seal protectors are serviced separately.

When re-lubrication of the ball joints is required, it is necessary to remove the plugs from the ball joints and install grease fittings. After lubrication is complete, remove the grease fittings and reinstall the plugs.

RUBBER BUSHINGS SHOULD NOT BE LUBRICATED AT ANY TIME. When replacement of a bushing is necessary, water may be used to aid in installation.

SERVICE PROCEDURES

1. PREPARATION FOR MEASURING FRONT END ALIGNMENT

The method of measuring alignment will vary de-

pending on the type of equipment being used. The instructions furnished by the manufacturer of the equipment should always be followed, however, the

specifications as recommended by Chrysler Corporation should always be followed.

All measurements and adjustments should be made in the following order:

- (1) Front Suspension Height
- (2) Caster and Camber
- (3) Toe-In
- (4) Steering Axis Inclination
- (5) Toe-Out on Turns

The measurement of steering axis inclination and toe-out on turns is valuable in determining if parts are bent, or damaged. **Bent or damaged suspension and steering linkage parts must be replaced. Do not attempt to modify any of these parts by heating and bending.** When replacements of this kind are made, it is important that other front end parts are inspected and front suspension aligned.

Before any attempt is made to check or correct caster, camber and toe-in, the following preliminary inspections and necessary corrections must be made on those parts which influence the steering of the vehicle.

(1) Inflate tires to recommended pressure. All tires should be the same size, in good condition and have equal wear. Note the type of wear to aid in diagnosing. (See "Wheel, Bearings and Tires" Group 22.)

(2) Inspect the suspension and steering linkage pivot points for excessive looseness; rear springs for proper tightness of "U" bolts and height differential between left and right sides of vehicle. The vehicle should be on a level floor or alignment rack and should have a full fuel tank with no luggage or passenger load.

(3) Adjust the front wheel bearings (See Paragraph 2). Measure front wheel and tire assembly run-out (Follow Equipment Manufacturers Instructions).

(4) To obtain accurate readings, the vehicle should be jounced in the following manner just prior to taking **each** measurement (Height—Caster—Camber and Toe-In): Grasp the bumpers at the center (rear bumper first) and jounce the car up and down several times. Release the bumpers on the down cycle after jouncing both rear and front of car an equal number of times.

2. FRONT WHEEL BEARING ADJUSTMENT (Fig. 1)

(1) Tighten the wheel bearing and adjusting nut to 90 inch-pounds while rotating the wheel.

(2) Position the nut lock on nut with one pair of slots in line with the cotter pin hole.

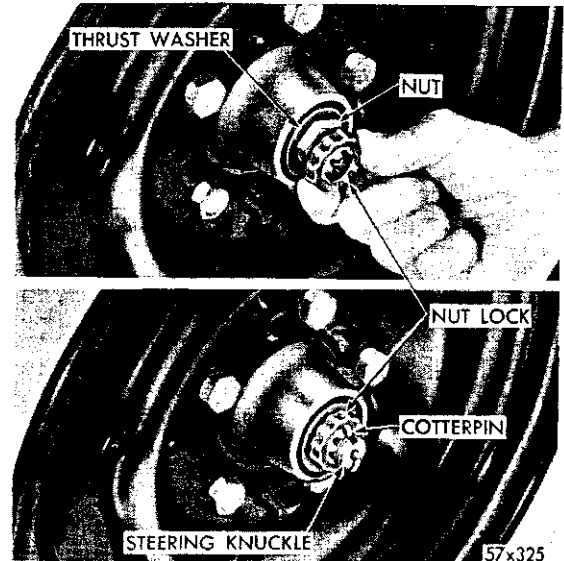

Fig. 1—Adjusting the Front Wheel Bearings

(3) Back off the lock and adjusting nut to the next slot.

(4) Install the cotter pin.

NOTE: The resulting adjustment should be zero (no preload to .003 inch end play).

(5) Clean the grease cap, coat the inside with wheel bearing lubricant (do not fill) and install.

3. FRONT SUSPENSION HEIGHT ADJUSTMENT

Without Using Tools C-3608 or C-3895

All models (except Town and Country, and C-300J): 2 inches \pm $\frac{1}{8}$ inch (Town and Country—2 $\frac{3}{8}$ inches \pm $\frac{1}{8}$ inch) TC-2—C-300J (High Performance)—1 $\frac{3}{4}$ inches \pm $\frac{1}{8}$ inch.

Front suspension heights must be held to specifications for a satisfactory ride, correct appearance, proper front wheel alignment and reduced tire wear.

The heights should only be measured when the vehicle has the recommended tire pressures, a full tank of fuel, no passenger load and is placed on a level floor.

(1) Clean all foreign material from the bottom of the lower ball joint assemblies and from the bottom of the lower control arm bushing housings between the flanges of the arms.

(2) Jounce the car several times releasing it on the downward motion.

(3) Measure the distance from the lowest point of one of the lower control arm bushing housings to the floor (measurement A) and from the flat portion

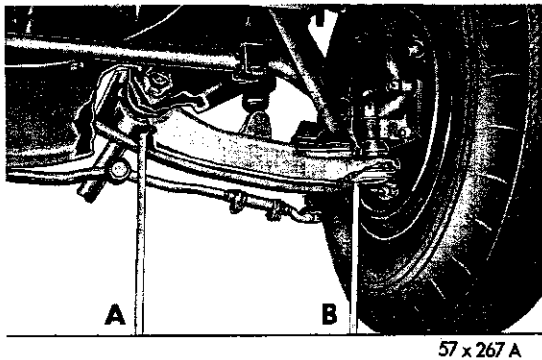

Fig. 2—Checking the Front Suspension Height

on the bottom of the lower ball joint on the same side (measurement B) to the floor (Fig. 2). **Measure only one side at a time.** The differential between measurement A and B should be as follows:

All models (except Town and Country and C-300J): 2 inches \pm $\frac{1}{8}$ inch; Town and Country—2 $\frac{3}{8}$ inches \pm $\frac{1}{8}$ inch

TC-2—C-300J (High Performance)—1 $\frac{3}{4}$ inches \pm $\frac{1}{8}$ inch.

(4) Measure the other side in the same manner. The difference from side to side should be no more than $\frac{1}{8}$ inch.

(5) Adjust if necessary by turning in the torsion bar adjusting bolt to increase the height and backing off the bolt to decrease the height.

(6) After each adjustment, jounce the vehicle before rechecking measurements. Both sides should be measured even though only one side has been adjusted.

Using Height and Level Gauge Tools C-3608 or C-3895

(1) Clean the bottom of the lower control arm ball joints and the control arm bushing housings.

(2) With the measuring pins of Tool C-3608 retracted, latch the tool retaining springs securely to the flanges of the control arms, making sure that the stop pads on the ends of the tool are in contact with the cleaned area of the ball joints.

(3) Carefully unlatch the measuring pins and guide them into contact with the cleaned surface of the bushing housings.

(4) Jounce the vehicle as outlined in Paragraph 1, Step 4.

(5) The reading on both measuring pins should be as follows:

All models (except Town and Country and C-300J): 2 inches \pm $\frac{1}{8}$ inch (Town and Country, 2 $\frac{3}{8}$ inches

\pm $\frac{1}{8}$ inch), (TC-2—C-300J (High Performance), 1 $\frac{3}{4}$ inches \pm $\frac{1}{8}$ inch).

(6) Adjust, if necessary, by turning the torsion bar anchor bolt clockwise to increase the height and counter-clockwise to decrease the height (Fig. 3). If it is necessary to adjust the anchor bolts, measure the torque required to move the bolt clockwise. If it requires over 200 foot-pounds, replace the anchor adjusting bolt.

(7) After adjusting, jounce the vehicle and read both gauges even though only one side may have been adjusted.

4. FRONT SUSPENSION ALIGNMENT

(Camber—Left Wheel + $\frac{1}{4}^{\circ}$ to + $\frac{3}{4}^{\circ}$ (Preferred + $\frac{1}{2}^{\circ}$)

Right Wheel 0 $^{\circ}$ to + $\frac{1}{2}^{\circ}$ (Preferred + $\frac{1}{4}^{\circ}$)

(Caster —Power Steering + $\frac{1}{4}^{\circ}$ to + $1\frac{1}{4}^{\circ}$
Manual Steering 0 $^{\circ}$ to - 1 $^{\circ}$

(Toe-In — $\frac{3}{32}$ to $\frac{5}{32}$ inch (Preferred $\frac{1}{8}$ inch)

Front suspension alignment settings must be held to specifications to hold tire wear to a minimum and to maintain steering ease and handling of the vehicle.

Alignment measurements should only be taken with the tires inflated to the recommended pressure, no passenger load, correct car height, full tank of fuel, and with the full weight of the vehicle on the wheels. The equipment manufacturers recommended procedure should always be followed. Any parts of the front suspension system should be replaced if they are found to be bent. **Do not attempt to straighten any bent part.**

Camber and Caster

(1) Remove all foreign material from the exposed

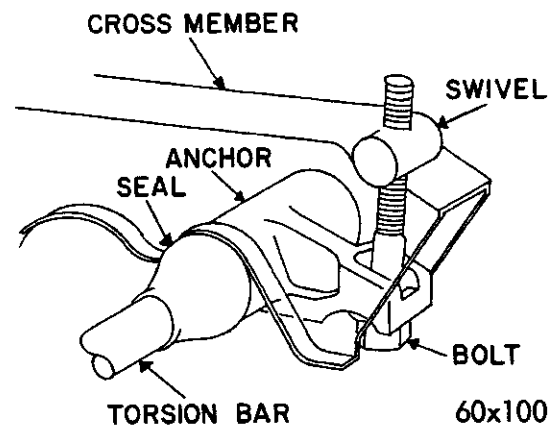

Fig. 3—Torsion Bar Adjustment Bolt

threads of the cam adjusting bolts.

(2) Prepare the vehicle for measurement as outlined in Paragraph 1.

(3) Take the initial camber and caster readings before loosening the cam bolt nuts.

(4) Camber and caster should be adjusted, if necessary, to the following specifications:

Camber—Left Wheel + ¼° to + ¾° (Preferred + ½°)

Right Wheel 0° to + ½° (Preferred + ¼°)

Caster —Power Steering + ¼° to 1¼°

Manual Steering 0° to - 1°

(5) Camber settings should be held as close as possible to the "preferred" setting. Caster should be held as nearly equal as possible on both wheels.

**Toe-in 3/32 to 5/32 inch
(Preferred 1/8 inch)**

The toe setting should be the final operation of the front wheel alignment adjustments. The front wheels must be in a straight ahead position. Follow the equipment manufacturers procedure. The steering wheel should be centered during this operation.

Turning both tie rod sleeves will "center" the steering wheel. If the steering wheel was centered, make the toe-in adjustment by turning both sleeves an equal amount. Be sure and tighten the clamp in such a position that the bolts are on the bottom, otherwise interference can result.

5. TORSION BARS

The torsion bars are not interchangeable side for side. The bars will be indicated as either right or left by an "R" or an "L" (right or left hand side) stamped on the end of the bars.

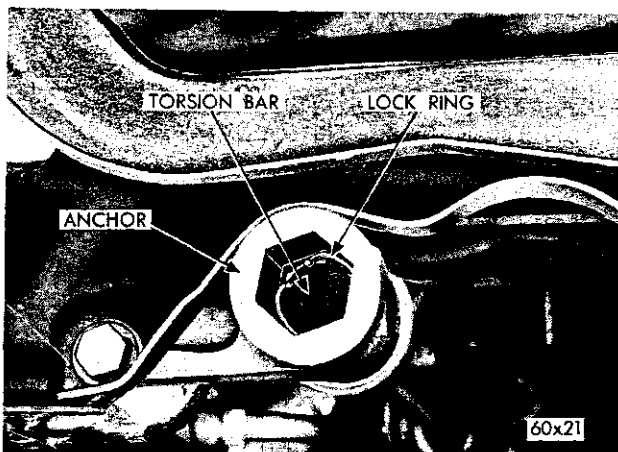

Fig. 4—Torsion Bar Lock Ring

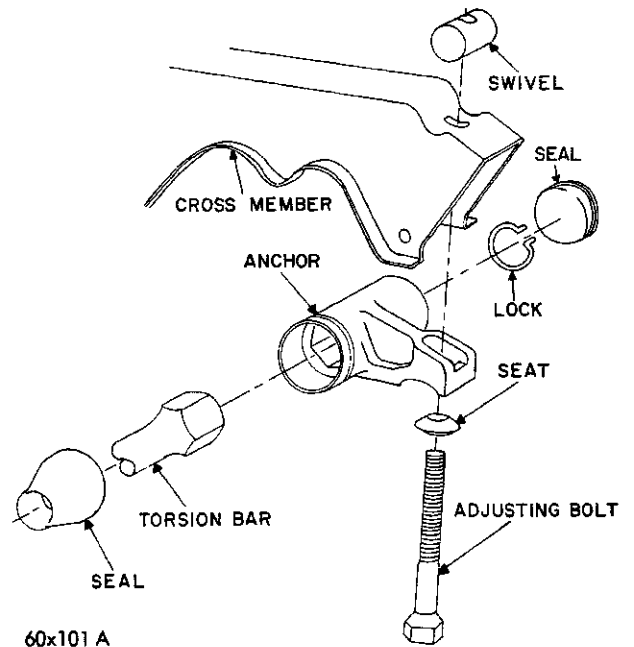

Fig. 5—Torsion Bar Rear Support Assembly

CAUTION: If the vehicle is to be raised on a hoist, make sure it is supported by the frame only so that the front suspension is in full rebound (under no load).

Removal

(1) Place a jack under the center of the front cross-member and raise the vehicle off the floor, so the front suspension is in full rebound (under no load).

(2) Release the load from the torsion bar by backing off the anchor adjusting bolts (Fig. 3). Remove the bolt and swivel and discard.

(3) Remove the plastic seal (Fig. 4) from the rear end of the torsion bar anchor. Remove the lock ring from the rear of the torsion bar anchor (Fig. 5).

(4) Slide the torsion bar toward the rear of the vehicle sufficiently to disengage the forward end from the lower control arm. Slide the torsion bar forward and down, disengaging it from the anchor. Remove the torsion bar from under the vehicle.

Installation

(1) Before installing the torsion bar, obtain a new adjusting bolt, swivel and torsion bar balloon seal. Install the torsion bar as follows:

(2) The torsion bars are marked (R) right and (L) left on the end. It is important that each torsion bar is installed on its respective side.

(3) Slide the new balloon seal over the torsion bar

2-6 FRONT SUSPENSION

(cupped side toward rear anchor).

(4) Apply a liberal coating of chassis lubricant around each end of the torsion bar. The rear end of the torsion bar should be coated equal to the depth of the anchor hub socket.

(5) Install the torsion bar (Fig. 3).

(6) Turn the torsion bar until the anchor end is positioned approximately 120 degrees (eight o'clock or four o'clock position) down from the frame.

(7) Engage the front end of the bar in the hex opening of the lower control arm. If the anchor end is not in the position just described when installing the torsion bar, it will be impossible to adjust the front suspension to the correct height.

(8) Before installing the lock ring, center the bar so that full contact is obtained at anchor and arm shaft. Install the lock ring, making sure it is seated in its groove.

(9) Pack the annular opening in the rear anchor completely full of multi-purpose lubricant. Position the lip of the seal in the groove in the anchor hub. Install the plastic seal into the rear end of the torsion bar anchor.

(10) Slide the adjusting bolt swivel in position on the frame. Hold in position while installing the new adjusting bolt and seat. Tighten the bolt into a new swivel until approximately 1 inch of threads are showing out of the swivel. This is an approximate setting and is to be used only as a starting point when adjusting for correct height. This setting is also necessary to place a load on the torsion bar before lowering the vehicle to the floor.

(11) Lower the vehicle to the floor, then measure and adjust the suspension as required.

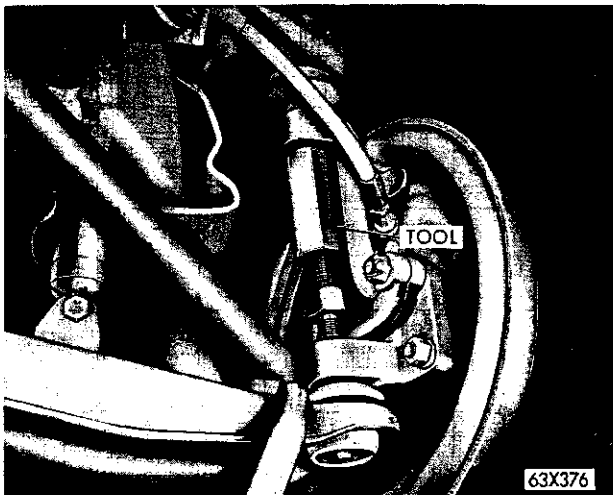

Fig. 6—Removing Lower Ball Joint from Knuckle

6. LOWER BALL JOINTS

The lower ball joints should not be replaced for looseness if the axial end play (up and down movement) is under .050 inch. Looseness of this nature is normal and will not affect front end alignment.

Removal

(1) Place a jack under the lower control arm and raise the vehicle.

(2) Remove the wheel, tire and drum assembly and the brake support plate.

(3) Remove the upper and lower ball joint and nuts. Slide Tool C-3564 over the upper stud until the tool rests on the steering knuckle. Turn the threaded portion of the tool locking it securely against the lower stud (Fig. 6). Spread the tool enough to place the lower stud under pressure, then strike the steering knuckle sharply with a hammer to loosen the stud. Do not attempt to force the stud out of the knuckle with the tool alone.

(4) Remove the tool, then disengage the ball joint from the knuckle.

(5) Using Tool C-3560 for Models TC-1, TC-2 and TC-3 or Tool C-3561 for TY-1, unscrew the ball joint housing from the lower control arm and remove.

The ball joint balloon type seal will come off as the ball joint is removed.

Installation

(1) When installing the new ball joint, it is very important that the ball joint threads properly engage those of the control arm. Screw the ball joint into the control arm as far as possible by hand.

(2) Using Tool C-3560 for Models TC-1, TC-2 and TC-3 or Tool C-3561 for TY-1, tighten the ball joint assembly to a minimum of 125 foot-pounds torque on (TC-1, TC-2 and TC-3 Models) and 150 foot-pounds on (TY-1 models) until seated in the control arm.

(3) Position the new ball joint balloon type seal on the ball joint body. Using Tool C-3736 on Models TC-1, TC-2 and TC-3, and Tool C-3867 on TY-1 install the seals. To facilitate installation of the seal, the ball joint stud should be perpendicular to the ball joint body.

(4) Install the brake support plate assembly. Tighten the brake support bolts to 55 foot-pounds torque and the knuckle arm bolts to 80 foot-pounds torque.

(5) Position the stud in the steering knuckle, and install the washer and nut. Tighten to 135 foot-pounds torque and install the cotter pin.

(6) Lubricate the joint with the specified lubricant

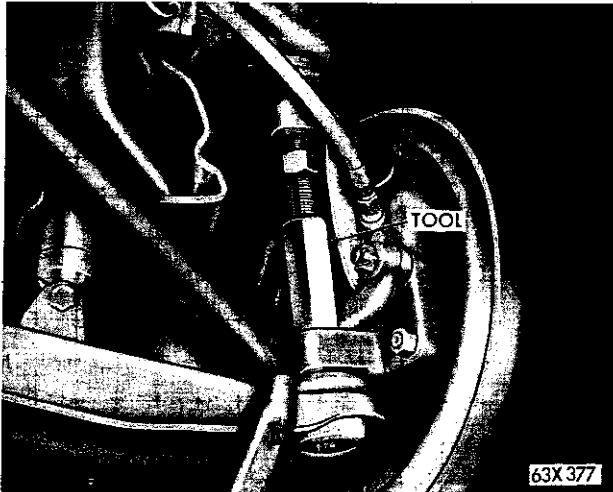

Fig. 7—Removing Upper Ball Joint from Knuckle

(by means of a hand gun only) through the plug hole in the bottom of the housing, until the lubricant is emitted from the seal. Install the plug.

(7) Install the wheel, tire and drum assembly. Adjust the front wheel bearings.

7. UPPER BALL JOINTS

Removal

(1) Place a jack under the lower control arm as close to the wheel as possible. Raise the wheel off the floor.

(2) Remove the wheel and tire assembly.

(3) Remove the upper and lower ball joint stud nuts. Slide Tool C-3564 down over the lower stud until the tool rests on the steering knuckle. Turn the

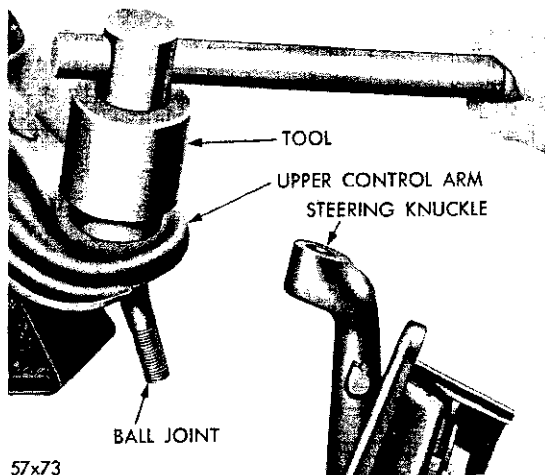

Fig. 8—Removing the Ball Joint

threaded portion of the tool locking it securely against the upper stud (Fig. 7). Spread the tool enough to place the upper stud under pressure, then strike the steering knuckle sharply with a hammer to loosen the stud. **Do not attempt to force the stud out of the knuckle with the tool alone.**

(4) Remove the tool, then disengage the ball joint from the knuckle.

(5) Using Tool C-3560 for models TC-1, TC-2 and TC-3 or Tool C-3561 for TY-1 (Fig. 8) unscrew the ball joint from the upper control arm.

The ball joint balloon type seal will come off as the ball joint is removed.

Installation

When installing a new ball joint, it is very important that the ball joint threads properly engage those of the control arm.

(1) Screw the ball joint squarely into the control arm as far as possible by hand.

(2) Using Tool C-3560, or C-3561 according to Model indicated as above, tighten until the ball joint housing is seated on the control arm. Tighten to a minimum of 125 foot-pounds torque on Models TC-1, TC-2, TC-3, and 150 foot-pounds torque on Models TY-1.

(3) Position the new ball joint balloon type seal on the ball joint body using Tool C-3736 on models TC-1, TC-2, and TC-3, and Tool C-3867 on TY-1; install the seals. **To facilitate installation of the seal the ball joint stud should be perpendicular to the ball joint body.**

(4) Position the stud in the steering knuckle. Install the washer and nut. Tighten the nut on Models TC-1, TC-2, TC-3 to 100 foot-pounds torque, and on Models TY-1 to 135 foot-pounds torque. Install the cotter pin.

(5) Repack the ball joint with the specified lubricant (by means of a hand gun only) through the plug hole in the top, until the lubricant is emitted from the seal. Install the plug.

(6) Install the wheel and tire and adjust the front wheel bearing (Paragraph 2).

8. LOWER CONTROL ARM STRUT

Removal (Fig. 9)

(1) Remove the nuts, lockwashers, and bolts that attach the sway bar bushing housings to the struts, disconnect the sway bar from the struts.

(2) Remove the strut to the lower control arm mounting bolts and nuts.

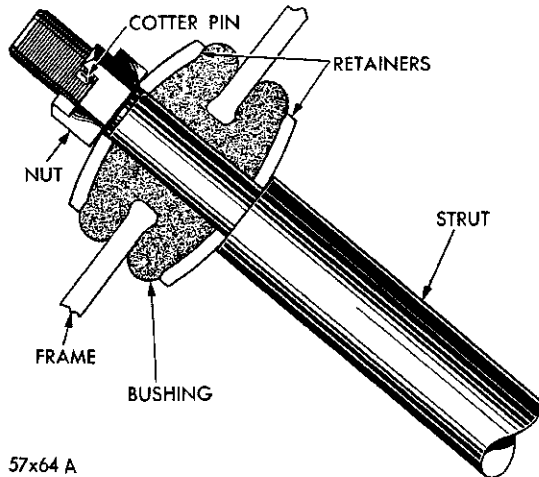

Fig. 9—Lower Control Arm Strut Mounting

- (3) Remove the nut and bushing retainer from the forward end of the strut at the crossmember.
- (4) Slide the strut and inner bushing retainer from the bushing in the frame.
- (5) Using a screwdriver, pry the bushing out of the front of the frame.

Installation

- (1) Dip the new bushing in water and with the tapered portion toward the rear of the vehicle, install the bushing in the opening in the frame using a twisting motion (and/or hammer) until the groove in the bushing indexes properly with the frame.
- (2) With the cupped side out, slide the washer over threaded end of the strut. Push the strut through the bushing in the frame, position the outer washer over the end of the strut (cupped side in) and install the nut.
- (3) Tighten the nut sufficiently to install the strut to the lower control arm mounting bolts. Install the bolts, lockwashers and nuts, and tighten to 100 foot-pounds torque.
- (4) Tighten the nut on the forward end of the strut to 40 foot-pounds torque with the full weight of the vehicle on the wheels.
- (5) Install the sway bar (if so equipped.)
- (6) Set the front end alignment.

9. LOWER CONTROL ARM AND SHAFT (Fig. 10)

Removal

- (1) Place a jack under the number 2 crossmember and raise the vehicle until both front wheels clear the floor.

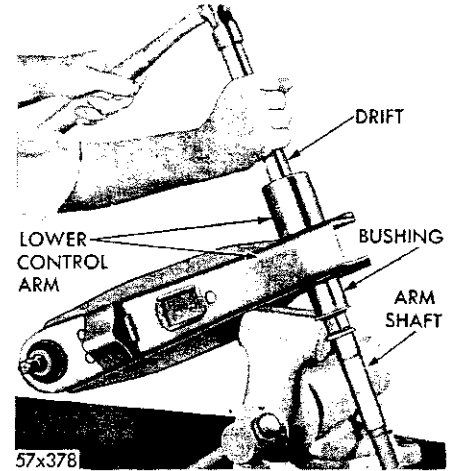

Fig. 10—Removing the Lower Control Arm Strut Assembly

- (2) Remove the torsion bar, Paragraph 5.
- (3) Remove the wheel, tire and drum assembly. Remove the brake support plate assembly.
- (4) Disconnect the shock absorber at the lower control arm bracket then push the shock absorber up into the frame out of the way.
- (5) Remove the nuts, lockwashers and bolts that attach the strut to the lower control arm.
- (6) Remove the upper and lower ball joint stud nuts. Slide Tool C-3564 over the upper stud until the tool rests on the steering knuckle. Turn the threaded portion of the tool locking it securely against the lower stud (Fig. 6). Spread the tool enough to place the lower stud under pressure, then strike the steering knuckle sharply with a hammer to loosen the stud. **Do not attempt to force the stud out of the knuckle with the tool alone.**
- (7) Remove the tool, and disengage the ball joint from the knuckle.
- (8) Remove the cotter pin, nut and washer that attaches the lower control arm shaft to the frame. With the washer and cotter pin removed, reinstall the nut until it is flush with the end of the shaft to protect the threads.
- (9) Using a hammer and brass drift, loosen the shaft (a tapered fit in front crossmember), then remove the nut. Slide the lower control arm and shaft out from the rear of the crossmember.

Disassembly

- (1) Place the lower control arm in an arbor press (with torsion bar hex opening up). Press the shaft and bushing out of the control arm, using a brass drift (Fig. 10).

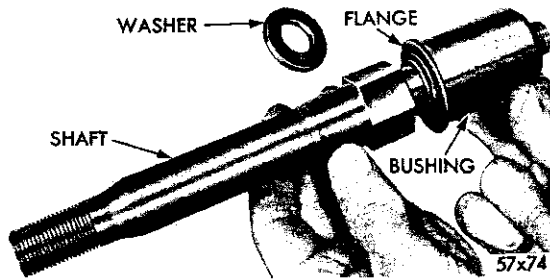

Fig. 11—Removing the Shaft Bushing

(2) Remove the cotter pin, nut and washer from the end of the shaft, and remove the bushing from the shaft (Fig. 11).

(3) Using Tool C-3560 for Models TC-1, TC-2, and TC-3 or Tool C-3561 for TY-1 unscrew the ball joint from the lower control arm.

The ball joint balloon type seal will come off as the ball joint is removed.

Assembly

(1) Position the new bushing over the shaft (flange end first) and seat on the shoulder of the shaft. Install the washer and nut, then tighten to 100 foot-pounds torque. (Hold shaft securely in a vise with protector jaws). Install the cotter pin.

(2) Press the lower control arm shaft and bushing into the lower control arm with an arbor press, or drive into place using Tool C-3556 for Models TC-1, TC-2 and TC-3 or Tool C-3557 for TY-1, and a hammer (Fig. 12).

(3) Press until the flanged position of the bushing is seated, beyond the locking groove.

(4) Thread the ball joint into the new arm using

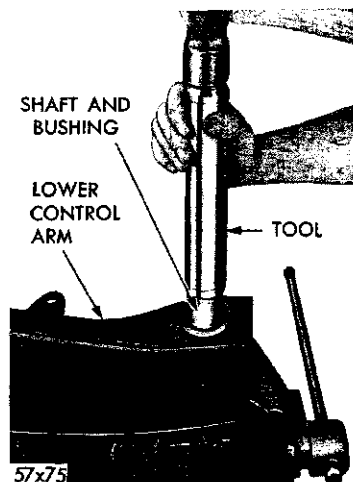

Fig. 12—Installing the Lower Control Arm Shaft Assembly

Tool C-3560 for Models TC-1, TC-2 and TC-3, or Tool C-3561 for TY-1.

(5) Tighten to a minimum of 125 foot-pounds torque on Models TC-1, TC-2 and TC-3, and 150 foot-pounds on Models TY-1 until the ball joint is seated (the ball joint will cut threads into the new arm during tightening operation).

Installation

Before installing the parts, clean all rust scale, and mud and other foreign matter off of the mounting surfaces.

(1) Position the shaft and control arm in the frame crossmember in approximate operating position. Install the washer and nut. **DO NOT TIGHTEN** the nut until the full weight of the vehicle is on the wheels.

(2) Position the new ball joint balloon type seal on the ball joint body and using Tool C-3736 on Models TC-1, TC-2 and TC-3, and Tool C-3867 on TY-1 install the seals. **To facilitate installation of the seal the ball joint stud should be perpendicular to the ball joint body.** Repack the joint with the specified lubricant, using a hand type grease gun only, through the plug hole in the bottom until the lubricant is emitted from the seal. Install the plug.

(3) Install the brake support plate assembly. Tighten brake support bolts to 55 foot-pounds torque and the knuckle arm bolts to 80 foot-pounds torque.

(4) Position the stud in the steering knuckle. Install the washer and nut. Tighten to 135 foot-pounds torque and install the cotter pin.

(5) Pull down the shock absorber from its position in the frame opening and engage with the mounting bracket on the lower control arm. Install the bolt, washer and nut. Tighten to 55 foot-pounds torque.

(6) Position the strut on the lower arm, install the bolts, washers and nuts. Tighten to 100 foot-pounds torque.

(7) Install the wheel, tire and drum assembly.

(8) Adjust the front wheel bearing, Paragraph 2.

(9) Install the torsion bar, Paragraph 5.

(10) Tighten the lower control arm shaft, (the 3/4 inch) nut to 180 foot-pounds torque for Models TC-1, TC-2 and TC-3 and (7/8 inch) nut 200 foot-pounds torque for Models TY-1. Install the cotter pin.

(11) Lower the vehicle to the floor, then measure and adjust the suspension heights as required.

(12) Set the front end alignment.

10. UPPER CONTROL ARM

Removal

The upper control arm support mounting brackets

2-10 FRONT SUSPENSION

are welded to the frame side rails.

(1) Place a jack under the lower control arm as close to the wheel as possible. Raise the jack until the front wheel clears the floor.

(2) Remove the wheel and tire assembly.

(3) Remove the upper and lower ball joint stud nuts. Slide the Tool C-3564 down over the lower stud until the tool rests on the steering knuckle. Turn the threaded portion of the tool locking it securely against the upper stud (Fig. 7). Spread the tool enough to place the upper stud under pressure then strike the knuckle sharply with a hammer to loosen the stud. Do not attempt to force the stud out of the knuckle with the tool alone.

(4) Remove the tool, then disengage the ball joint from the knuckle.

(5) Remove the nuts, lockwashers and bolts attaching the upper control arm bushings to the front and rear support. Lift the upper control arm up and away from the support.

Disassembly

(1) Remove the ball joint using Tool C-3560 for Models TC-1, TC-2 and TC-3, or Tool C-3561 for TY-1. The ball joint balloon type seal will come off as the ball joint is removed.

(2) Assemble Tool C-3710 (using adaptor SP-3826 in place of SP-3088) over the bushing and press the bushing out of the arm (from inside out) (Fig. 13). The bushing support sleeve will come off as the bushing is removed. **Be sure the control arm is firmly supported if a hammer and drift is used in place of the tool.**

NOTE: Tool C-3669 with adaptor SP-3233A is the same as Tool C-3710.

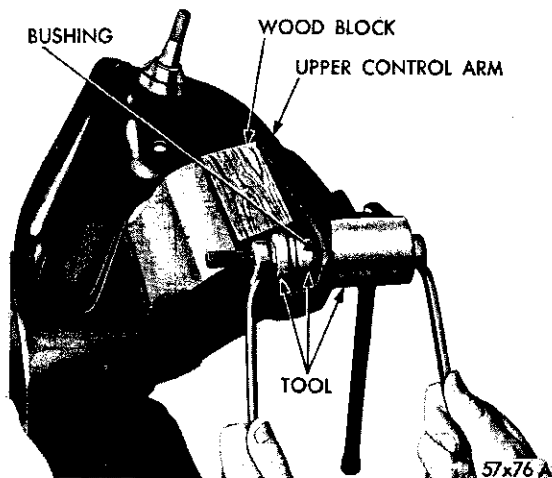

Fig. 13—Removing the Upper Control Arm Bushing

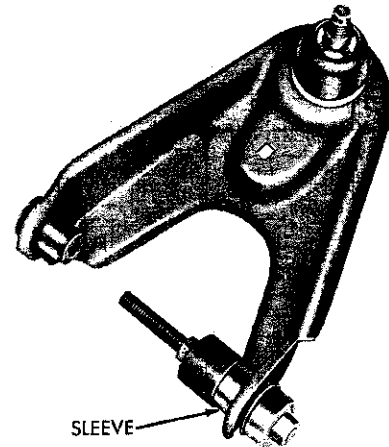

Fig. 14—Installing the Upper Control Arm Bushing Support Sleeve

Assembly

When installing the new bushings, be sure the control arm is supported squarely at the point where the bushing is being pressed in. **Do not use oil or grease to aid in installation.**

(1) Position the flange end of the new bushing in Tool C-3710 and then support the control arm squarely.

(2) Force the bushings into the control arm (from outside) until the tapered portion of the bushing seats on the arm.

(3) Remove the tool and install adaptor SP-3827 in place of SP-3233A cup on the tool and install the bushing support sleeve (Fig. 14).

(4) Thread the ball joint into the arm using Tool C-3560 for Models TC-1, TC-2 and TC-3, or Tool C-3561 for TY-1.

(5) Tighten to a minimum of 125 foot-pounds torque on Models TC-1, TC-2 and TC-3 and 150 foot-pounds on Model TY-1 until seated. The ball joint will cut threads into the arm during the tightening operation. After the bushings have been pressed in place, install the upper control arm on the vehicle.

Installation

(1) Slide the upper control arm into position. Install the arm washers and nuts and tighten the nuts 55 to 65 foot-pounds torque after setting the front end alignment.

(2) Position the new ball joint balloon type seal on the ball joint body, and using Tool C-3736 on Models TC-1, TC-2 and TC-3, and Tool C-3867 on TY-1, install the seals. **To facilitate installation of the seal the ball joint stud should be perpendicular to the ball joint body.** Repack the joint with the specified lubri-

cant, using a hand type grease gun only, through the plug hole in the top, until the lubricant is emitted from the seal. Install the plug.

(3) Position the stud in the steering knuckle. Install the washer and nut. Tighten the nut on Models TC-1, TC-2 and TC-3 100 foot-pounds and on Model TY-1 135 foot-pounds torque. Install the cotter pin.

(4) Install the wheel and tire and tighten in specified sequence (see "Wheel and Tires" Group 22). Adjust the front wheel bearing. Remove the jack.

(5) Set the front end alignment.

11. STEERING KNUCKLES

Removal

(1) Place a jack under the lower control arm as near to the wheel as possible. Remove the wheel, tire and drum. **Be sure the brake shoes are covered to prevent dirt or grease from soiling the lining.**

(2) Remove the cotter pins, nuts and lockwashers that attach the steering arm and brake support plate assembly to the steering knuckle. Remove the steering arm, brake support plate assembly from the steering knuckle as an assembly but leaving the brake hose attached. **Do not allow the assembly to hang by the brake hose.**

(3) Remove the ball joint studs from the steering knuckles. Lift the steering knuckle out and away from the vehicle.

Installation

(1) Position the upper and lower ball joint studs into the steering knuckle and install the lockwasher and nuts. Tighten the upper ball joint stud nut to 100 foot-pounds torque on Models TC-1, TC-2 and TC-3 and 135 foot-pounds torque on TY-1. Tighten the lower ball joint stud nut to 135 foot-pounds torque and install the cotter pin.

(2) Slide the brake support plate assembly over the knuckle and into position. Install the lockwashers and nuts on the upper rear and lower front bolts.

(3) Install the upper front and lower rear bolts through the brake support plate and steering knuckle. Position the steering arm over the bolts. Install lockwashers and nuts. Tighten the steering knuckle to brake support bolts 55 foot-pounds torque and the steering knuckle to steering knuckle arm bolts 80 foot-pounds torque. Install the cotter pins.

(4) Remove the covering from the brake shoes. Install the wheel, tire and drum assembly. Adjust the front wheel bearings. (Refer to Paragraph 2.)

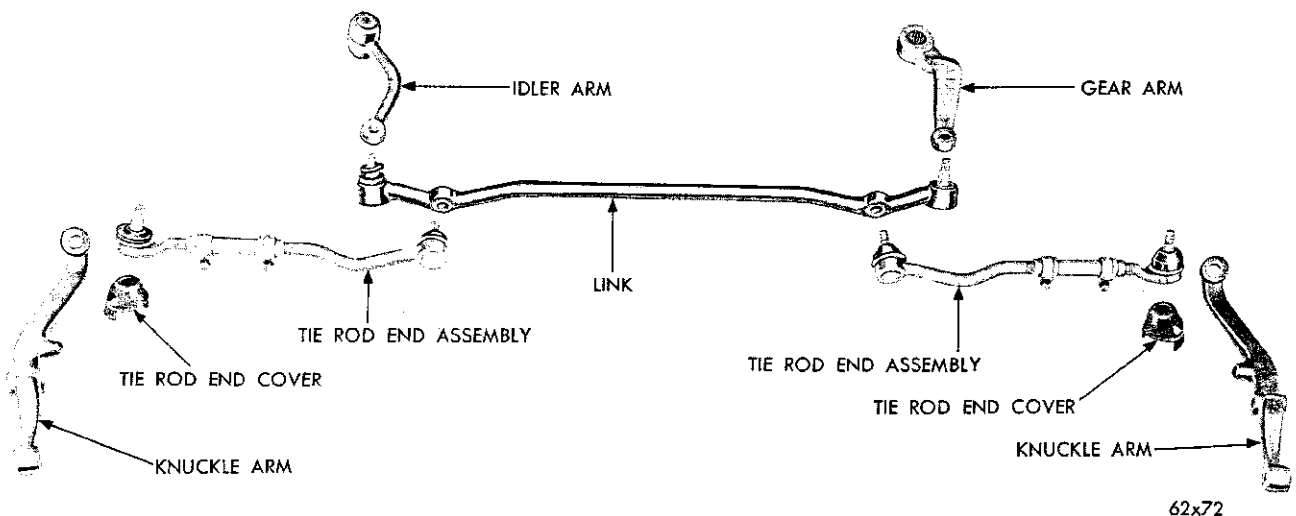

62x72

Fig. 15—Steering Linkage

12. STEERING LINKAGE (Fig. 15)

Removal

When removing the tie rod ends, idler arm or steering gear arm, all seals should be closely inspected for wear or damage. The tie rod ends are the permanently lubricated type. If the tie rod or steering arm seals are damaged replace the assembly.

The tie rod, seals and covers should be inspected at all oil change periods. Damaged seals necessitate replacement of the tie rod end assembly. The tie rod end seal covers are serviced separately.

CAUTION: Removal of the tie rod ends from the steering knuckle arm or center link by methods other than using Tool C-3894 will damage the tie rod end seal, necessitating replacement of the complete tie rod end assembly.

- (1) Remove the tie rod ends from the steering knuckle arms using Tool C-3894. Use care not to damage seals.
- (2) Using Tool C-3794 remove the inner tie rod ends from the link.
- (3) Remove the idler arm stud from the link, using Tool C-3894.
- (4) Remove the idler arm bolt from the cross-member.
- (5) Remove the steering gear arm stud from the link, using Tool C-3894.

Installation

Replace all tie rod and steering arm assemblies that are damaged, worn, or may have damaged seals.

- (1) Insert the idler arm and bushing assembly into the bracket using care not to damage the bushing. Insert the bolt and tighten to 85 foot-pounds torque.
- (2) Insert the center link studs into the idler arm and steering arm and tighten the nut to 40 foot-pounds torque.

(3) Connect the tie rod ends to the steering knuckle arms. Tighten the nuts to 40 foot-pounds. Slide the stone protector into position and install the cotter-pins.

- (4) Measure and adjust the front wheel toe-in.

13. SWAY BAR (Models so Equipped)

Removal

(1) Remove the two sway bar link retaining nuts and concave washers.

(2) Remove the two sway bar cushion retaining nuts, lockwashers and bolts, (one to each strut). Slide the sway bar out through the control arm struts and away from the vehicle. **The sway bar cushions are not serviced separately. If replacement is necessary, install a new sway bar assembly. Remove the lower concave washers.**

(3) Remove the sway bar link insulating bushings from the frame bracket. If the bushings are worn or deteriorated, install new bushings as required.

Installation

(1) Dip the new sway bar link bushings in water and install in the opening in the frame bracket, using a twisting motion. When installed properly, the groove in the bushing will index with opening in the frame bracket.

(2) Thread the sway bar into position over the top of the lower control arm struts.

(3) Engage the sway bar cushion housings with the struts and install lock plates. Insert the bolts, lock-washers and nuts and tighten to 35 foot-pounds torque.

(4) Install the washers over the ends of the links (concave side up), then slide the links up through the bushings. Install the washers (concave side down), over the ends of the links and down on the bushings. Install the nuts and tighten to 100 inch-pounds torque.

SERVICE DIAGNOSIS

Conditions	Possible Cause	Corrections
14. Front End Noise	(a) Ball joint needs lubrication.	(a) Lubricate ball joint (see Lubrication Group "O").
	(b) Shock absorber and bushings worn or loose.	(b) Replace bushings.
	(c) Worn strut bushings.	(c) Replace bushing.
	(d) Loose struts—Lower control arm bolts and nuts.	(d) Tighten all bolts and nuts.

SERVICE DIAGNOSIS—(Continued)

Conditions	Possible Cause	Corrections
	(e) Loose steering gear on frame.	(e) Tighten the steering gear mounting bolts.
	(f) Worn upper control arm bushings.	(f) Replace the worn bushings.
	(g) Worn lower control arm shaft bushings.	(g) Replace the worn bushings.
	(h) Worn upper ball joint.	(h) Replace the ball joint.
	(i) Worn lower ball joint.	(i) Replace the ball joint.
	(j) Worn tie rod ends.	(j) Replace the tie rod end.
	(k) Loose or worn front wheel bearings.	(k) Adjust or replace the bearings as necessary.
15. Instability	(a) Low or uneven tire pressure.	(a) Inflate the tires to correct pressure.
	(b) Loose wheel bearings.	(b) Adjust the wheel bearing.
	(c) Improper steering cross shaft adjustment.	(c) Adjust the steering cross shaft.
	(d) Steering gear not centered.	(d) Adjust the steering gear.
	(e) Worn idler arm bushing.	(e) Replace the bushing.
	(f) Loose or failed front strut bushings.	(f) Replace the bushings.
	(g) Weak or broken rear spring.	(g) Replace the spring.
	(h) Incorrect front suspension alignment.	(h) Measure and adjust the front end alignment.
	(i) Shock absorber inoperative.	(i) Replace the shock absorber.
16. Hard Steering	(a) Ball joints—insufficient lubrication.	(a) Lubricate the ball joints.
	(b) Low or uneven tire pressure.	(b) Inflate the tires to the recommended pressures.
	(c) Low power steering fluid level. (On Power Steering equipped cars.)	(c) Fill the power steering pump reservoir to level with MoPar Power Steering Fluid.
	(d) Lack of assist of power steering system.	(d) Inspect and test the power steering pump and steering gear. Service the power steering pump or gear as required.
	(e) Incorrect front end alignment (particularly caster) resulting from one of the following: (a) Upper control arm bent. (b) Lower control arm bent. (c) Steering knuckle or steering knuckle arm bent.	(e) Replace the bent part, and align suspension.
	(f) Steering gear low on lubricant.	(f) Fill the steering gear to the correct level.
	(g) Steering gear not adjusted properly.	(g) Adjust the steering gear.
	(h) Idler arm binding.	(h) Free-up the idler arm.
17. Car Pulls To One Side	(a) Low or uneven tire pressure.	(a) Inflate the tires to the recommended pressure.
	(b) Front brake dragging.	(b) Adjust the brakes.
	(c) Grease, lubricant or brake fluid leaking onto brake lining.	(c) Replace brake shoe and lining as necessary and stop all leaks.
	(d) Loose or failed strut bushings.	(d) Adjust or replace the strut bushings.
	(e) Power steering control valve out of adjustment.	(e) Adjust the steering gear control valve.

SERVICE DIAGNOSIS—(Continued)

Condition	Possible Cause	Corrections
18. Excessive Play in Steering	(f) Incorrect front end alignment (particularly camber).	(f) Adjust the front end alignment.
	(g) Broken or weak rear spring.	(g) Replace the spring.
	(a) Worn or loose front wheel bearings.	(a) Adjust or replace the wheel bearings as necessary.
	(b) Incorrect steering gear adjustment.	(b) Adjust the steering gear.
	(c) Loose steering gear to frame mounting bolts.	(c) Tighten the steering gear to frame bolts.
	(d) Worn ball joints or tie rod.	(d) Replace the ball joints on tie rods as necessary.
19. Front Wheel Shimmy	(e) Worn steering gear parts.	(e) Replace worn steering gear parts and adjust steering gear as necessary.
	(f) Worn upper control arm ball joints.	(f) Replace the ball joints.
	(g) Worn lower control arm ball joints.	(g) Replace the ball joints.
	(a) Tire, wheel out of balance.	(a) Balance the wheel and tire assembly.
	(b) Uneven tire wear, or extremely worn tires.	(b) Rotate or replace the tires as necessary.
	(c) Worn or loose wheel bearings.	(c) Replace or adjust the wheel bearings as necessary.
	(d) Worn tie rod ends.	(d) Replace the tie rod ends.
	(e) Strut mounting bushings loose or worn.	(e) Replace the strut mounting bushings.
	(f) Incorrect front end alignment (particularly caster).	(f) Adjust the front end alignment.