

GROUP 13

FRAME

CONTENTS

	Page		Page
Body to Frame Alignment (Chrysler).....	6	Frame Alignment Measurement (Chrysler).....	3
Frame Alignment:.....	1	Frame Replacement (Chrysler).....	4
Frame Alignment Measurement (Imperial).....	1	Gauge Alignment Adapter Chart.....	6

Imperial

A full length box section frame with redesigned crossmembers and full length side rails are used on all Imperial Models.

Two front crossmembers are used, the forward member for bumper, radiator support and strut attachment and the other for engine and suspension support.

The convertible coupe frames have X-members to reinforce the frame to body attachment.

Chrysler

The stub frame used on all Chrysler models is attached to the body at ten locations—four at brackets extending down from the cowl panel and six under the front passenger compartment where the frame is joined to the underbody crossmember. Shimming of the stub frame outriggers, to keep them in alignment with the balance of the frame is performed prior to the body being installed on the frame.

SERVICE PROCEDURES

1. FRAME ALIGNMENT MEASUREMENT (Imperial)

Frame members can often be satisfactorily straightened to the required dimensional limits.

NOTE: Under no circumstances should the control

arms, knuckles, steering arms or torsion bars be heated for straightening. Heating these parts will anneal the metal and lower their strength to a point which will make them dangerously weak for further use.

Figures 1 and 2 show various dimensions to be used

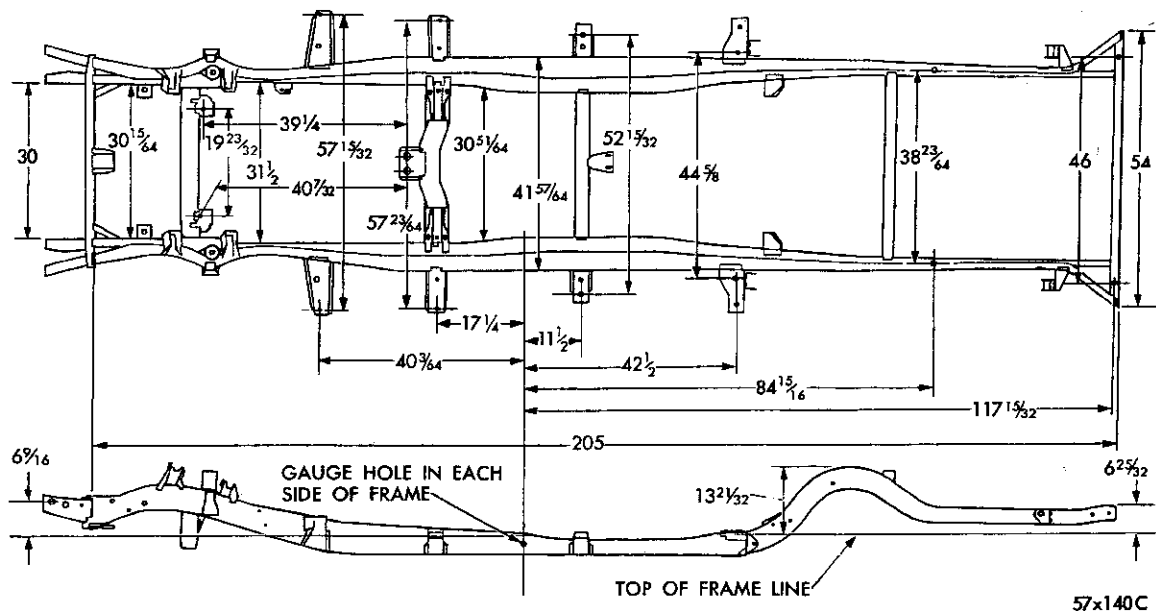

Fig. 1—Frame Dimensions (Imperial)

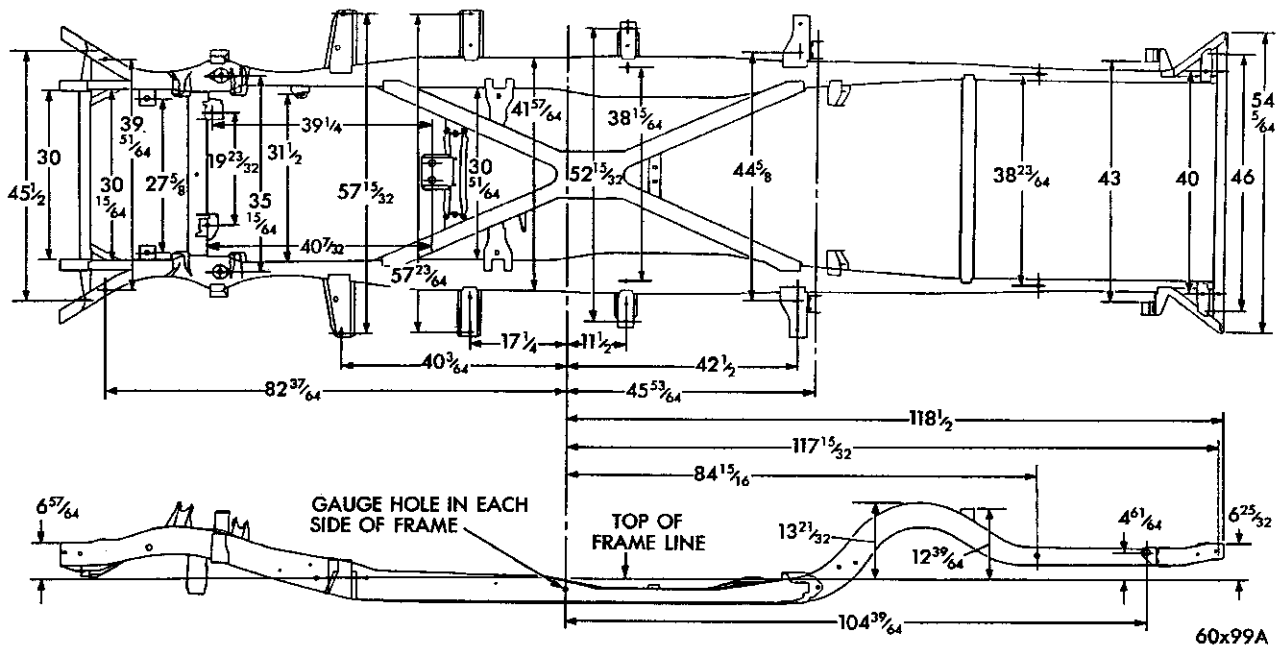

Fig. 2—Frame Dimensions (Imperial—Convertible)

as a guide for measuring frame alignment. These dimensions are the true distance between two points as measured with a steel tape.

Figures 1 and 2 show various measurements that may be taken to measure frame alignment. Diagonal measurements will quickly determine which section of the frame is bent and where force should be applied to restore the correct alignment.

2. FRAME ALIGNMENT (Imperial)

To properly measure a frame for alignment, diagonal measurement should be performed with great care. When the body is removed, the frame may be easily measured for alignment by measuring the diagonals with trammels or steel tape and check the dimensions given in Figures 1 and 2. Measurements may be taken without removing the body from the chassis by using a plumb-bob and chalk line on a level floor.

Attach the line of a plumb-bob to one of the rear body bolts. The plumb-bob should be suspended slightly above the floor. When the plumb-bob comes to rest, mark the floor directly underneath it. The marks made on the floor will represent the various points of the frame to be checked diagonally. Move the vehicle away so the distance can be measured to compare with the diagonal measurements.

The body support brackets are welded to the frame

in manufacturing. Due to "Box" construction of the frame the rivets cannot be used to attach a new body bracket to the frame.

Cut the damaged bracket off the frame and file the surface smooth. Clamp a new bracket in correct position and weld securely to the frame member. The

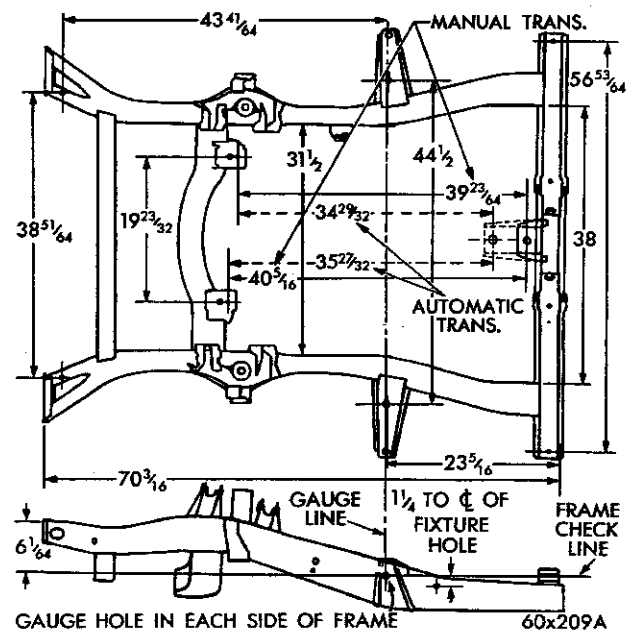

Fig. 3—Frame Dimensions (Newport, 300, New Yorker)

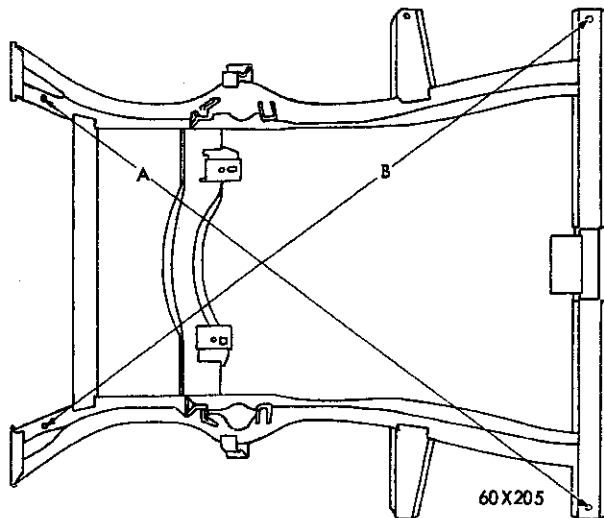

Fig. 4—Frame Diagonal Measurements

shielded arc-weld method is recommended for frame welding, or replacement of body frame support brackets. The heat generated from the welding operation is localized and burning of material is held to a minimum when a mild steel welding rod is used.

3. FRAME ALIGNMENT MEASUREMENT (Chrysler)

The various frame dimensions as shown in Figures 3 and 4 may be used as a guide in measuring the frame alignment.

Measure the distance between the points connected by line "A", in Figure 2, this distance should agree within 1/4 inch with the distance between the points connected by line "B".

The diagonals shown in Figure 3 represent only one of a few that may be measured. Many other diagonals

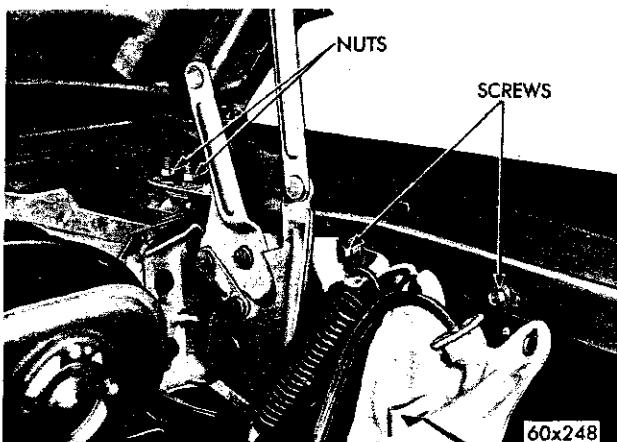

Fig. 5—Fender to Cowl Mounting

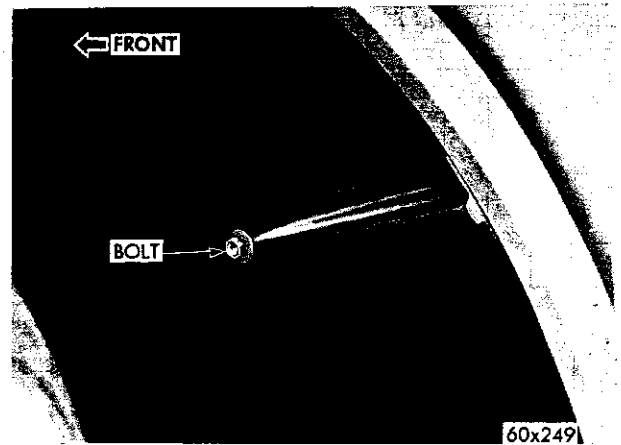

Fig. 6—Splash Shield to Cowl Mounting

may be measured in the same way.

NOTE: Care should be taken to make sure that any two diagonals compared represent exactly corresponding points on each side of the frame.

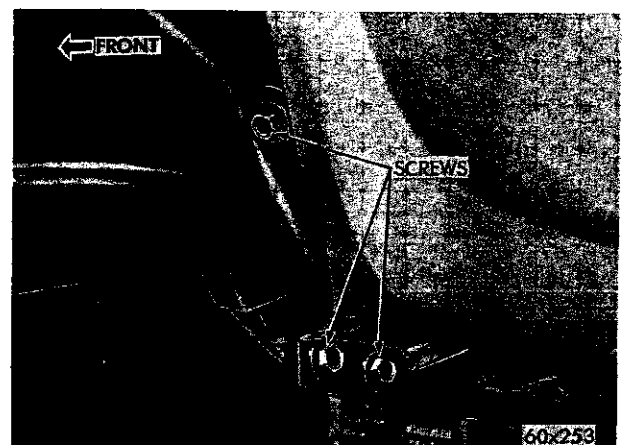

Fig. 7—Splash Shield to Body Frame Mounting

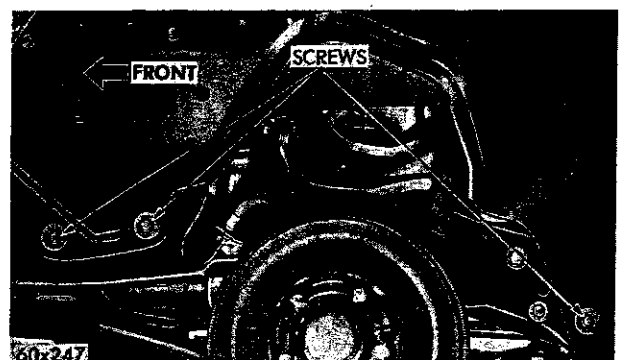

Fig. 8—Splash Shield to Stub Frame Mounting

2. FRAME REPLACEMENT (Chrysler)

Removal

- (1) Drain the radiator and remove the battery.
- (2) Remove the front bumper and the hood assembly.
- (3) Disconnect the radiator hoses, the head lamp wires and the horn wires.
- (4) Remove the hood hinge to the fender mounting screws (one each side).
- (5) Remove the upper nuts and studs (two at each side) attaching the fender to the cowl panel (Fig. 5).
- (6) Remove the bolts attaching the splash shields to the cowl (Fig. 6).
- (7) Remove the splash shield to body frame mounting bolts (Fig. 7) and the splash shield to stub frame mounting bolts (Fig. 8).
- (8) Remove the fender to body sill bolts (two each side), (Fig. 7) and the fender to body post bolts.
- (9) Remove the bolts attaching the front end sheet metal to the stub frame yokes (Fig. 9).
- (10) Disconnect the radiator yoke from the frame.
- (11) Raise the fenders off the mounting studs at the cowl and remove all front end sheet metal, and radiator as an assembly. With all front end sheet metal removed, raise the vehicle on a hoist.
- (12) Disconnect the propeller shaft and the transmission push button cable from the transmission. Disconnect the exhaust pipe at the front of the muffler. Disconnect the parking brake cable.
- (13) Remove the jacket tube at the instrument panel.
- (14) Disconnect the steering gear tube at the lower coupling. Disconnect the coupling from the steering

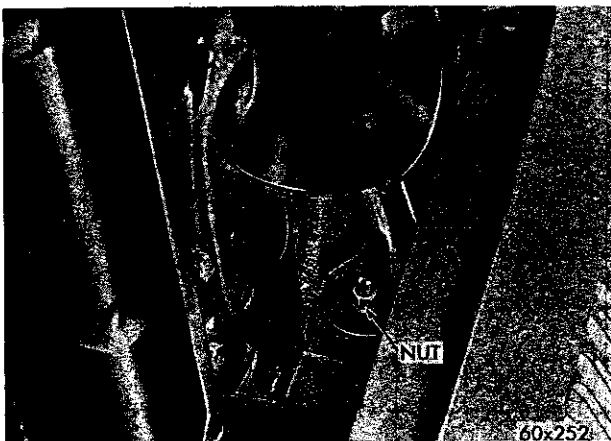

Fig. 9—Radiator Support to Frame Yoke Mounting

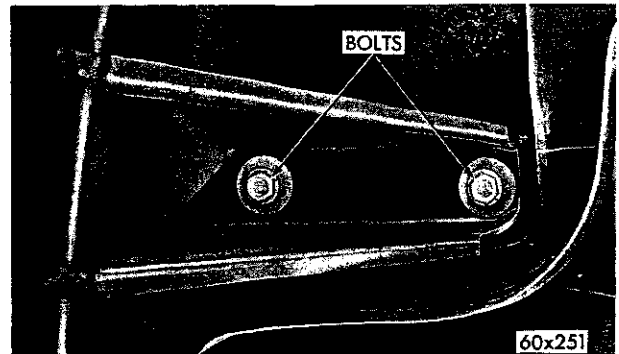

Fig. 10—Body to Frame Outrigger Mounting

gear by pushing the steering column up into the driver's compartment.

- (15) Remove the steering gear arm and the steering gear to frame mounting bolts.
 - (16) Disconnect the fuel line from the flexible connection at the rear of the stub frame right side rail.
 - (17) Remove the brake line from the "tee" on the rear axle and at the "tee" on the stub frame right side rail.
 - (18) Lower and place the vehicle on floor stands. The floor stands should be placed under the rear axle housing and under the forward edge of the floor sills.
- NOTE:** To protect the floor sills, wooden blocks should be placed between the floor stands and the floor sills.
- (19) Disconnect all electrical wires from the engine. Disconnect the power steering hoses (if so equipped), brake lines at the master cylinder, carburetor, throttle linkage and the heater hoses.

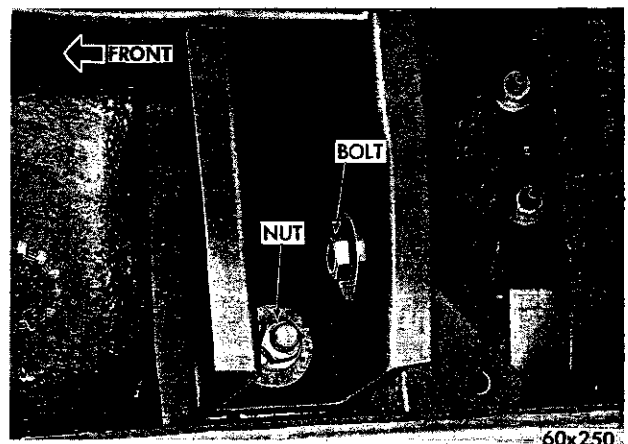

Fig. 11—Body to Frame Crossmember Mounting

(20) Place a hydraulic jack under the stub frame rear crossmember to hold it in position when the body to the frame mounting bolts (Figs. 10 and 11) are removed.

NOTE: Two bolts are located near the top of the curved portion of the body to frame crossmember.

(21) Remove the frame to body bolts. Lower the stub frame and engine assembly and roll out from under the body.

Installation

If frame is to be replaced, remove the engine and transmission, and all serviceable units from the old frame and install them on the new frame.

(1) Position the frame and engine assembly under the body.

(2) Install the body to frame bolts and tighten to 75 foot-pounds torque and measure the body to stub frame alignment. See Paragraph 3, "Body to Frame Alignment".

(4) Raise the vehicle and connect the exhaust pipe to the muffler and the propeller shaft to the transmission.

(5) Connect the fuel line to the flexible connector at the rear of the frame right side rail.

(6) Install the steering gear on the frame. Install the steering gear arm and link.

(7) Position the steering gear column, tube and coupling on the steering gear worm shaft. Position the steering column jacket tube at the instrument panel and tighten the bolts finger tight. Tighten the coupling bolt at the worm shaft coupling. Tighten the instrument clamp bolt securely.

(8) Install the brake line to the rear axle tee.

(9) Lower the vehicle to the floor and connect the brake lines to the master cylinder.

(10) Connect the power steering hoses (on Power Steering equipped cars) and the heater hoses.

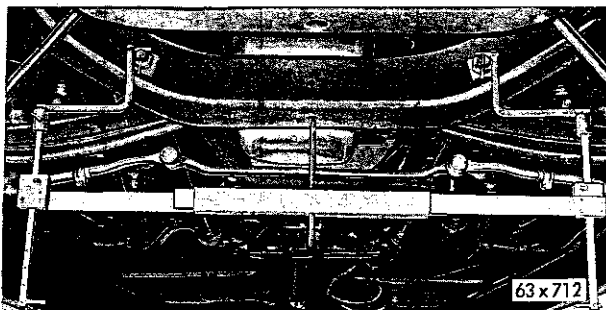

Fig. 12—Front Alignment Gauge Installed

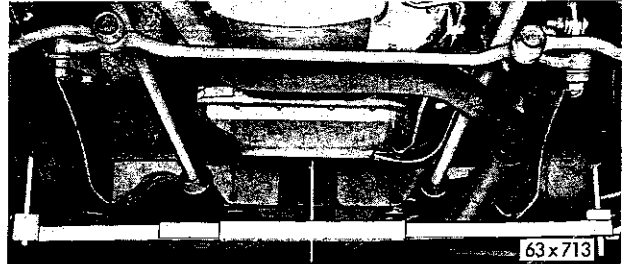

Fig. 13—Center Alignment Gauge Installed

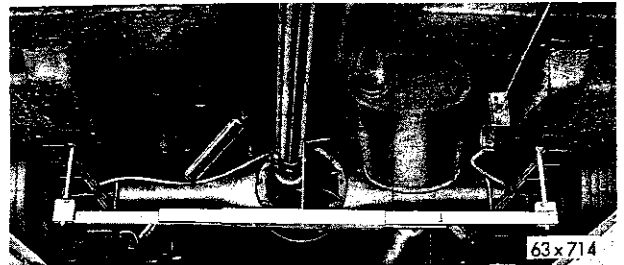

Fig. 14—Rear Alignment Gauge Installed

(11) Connect the carburetor and throttle linkage.

(12) Connect the parking brake cable. Adjust as necessary.

(13) Connect all electrical wires to the engine.

(14) Position the front end sheet metal on the frame and install the mounting bolts loosely. Align the front end sheet metal and tighten all mounting bolts securely.

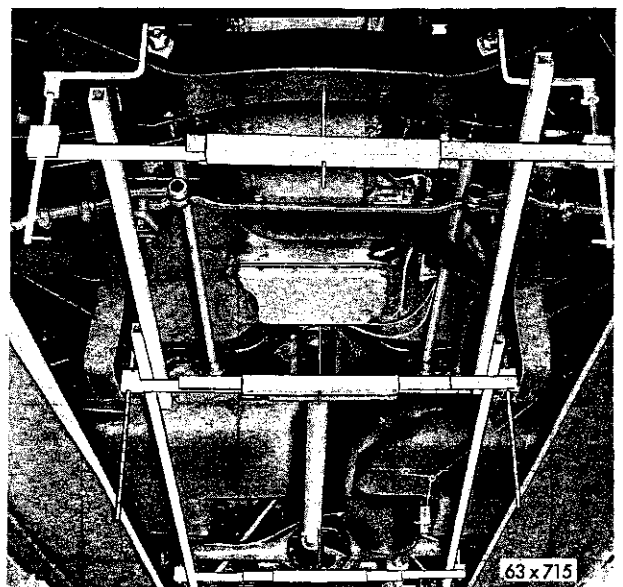

Fig. 15—Horizontal Checking Bars in Position

13-6 FRAME

(15) Connect the radiator hoses, head lamp wires and horn wires. Fill the cooling system.

(16) Raise the car and connect the transmission push button cable. Adjust the cable and lower car to floor.

(17) Refill the power steering unit (if so equipped) with Mopar Power Steering fluid. Part Number 2084329.

(18) Bleed and refill the braking system.

(19) Measure the front end height and adjust as necessary.

(20) Measure the front end alignment and adjust as necessary.

3. BODY TO FRAME ALIGNMENT (Chrysler)

The body to Frame Alignment measurement should be performed whenever the stub frame has been removed, replaced, repaired or the front end sheet metal cannot be properly aligned.

To measure the body to frame alignment, using Tool C-3802, refer to the "Gauge Adapter Chart" to determine the correct gauge adapter positions.

(1) Remove the cotter pins from the lower control arm shafts and position the 36 inch gauge on the shaft nuts, as shown in Figure 12 and 13.

(2) Using the 45 inch gauge (middle gauge) position the gauge adapter in the frame gauge holes, as shown in Figure 14.

(3) Place the horizontal alignment bars on the suspended gauges. The short bars are positioned on the front and center gauges and the long bars are positioned on the center and rear gauges, as shown in Figure 15.

(4) The long and short bar should be placed against each other to determine if any body to frame deflection is evident.

(5) The top and bottom surfaces of the horizontal bars should be perfectly level across their combined surfaces where they meet, however, if this condition is not prevailing, raise both the long and short bar as a unit until they are perfectly level.



Fig. 16—Checking Body to Frame Alignment

(6) Measure the space, created by leveling the bars, between the bars and the center gauge (Fig. 16).

The preferred spacing between the horizontal bars and the center gauge is 0 inch \pm $\frac{1}{16}$ inch. The differential measurements between one side to the other should not exceed $\frac{1}{8}$ inch.

Example—Right side reads $+\frac{1}{16}$ ". Left side should not exceed $-\frac{1}{16}$ ".

Should the measurements be out of limits of the recommended settings, it will be necessary to install the slotted shims, available in $\frac{1}{16}$ and $\frac{1}{8}$ inch thicknesses between the stub frame outriggers and the body front mounting brackets.

For example—if the measurements at the center gauge is $\pm \frac{1}{8}$ ", insert the necessary amount of shims at the front mounting brackets.

After the frame to body adjustment is performed, remove the measuring gauges, and install the cotter pins in the lower control arm shafts.

GAUGE ALIGNMENT ADAPTER CHART

Model	Wheelbase	Front Gauge	Center Gauge	Rear Gauge
TC-1, TC-2, TC-3...	122	B	A	D
Town and Country...		C	C	C