

ELECTRICAL**GROUP 8****CONTENTS****PART 1—BATTERY**

	Page		Page
Adjustment of Acid Gravity	10	Service Diagnosis	81
Battery Visual Inspection	7	Specific Gravity Test	8
Charging the Battery High Rate Discharge Test	9	Specifications	3
of Battery Capacity	9	Voltage Tests	8

PART 2—STARTING MOTOR (DIRECT DRIVE)

Circuit Tests	11	Drive Unit	15
Brushes	14	Field Coils	14
Specifications	3	Service Diagnosis	82
Drive Gear Clearance	16	Starting Motor Removal and Installation	11

PART 2—STARTING MOTOR (REDUCTION GEAR TYPE)

Brushes and Springs	22	Resistance and Current Draw	19
Specifications	3	Service Diagnosis	82
Field Coils	22	Starter Clutch Unit	24
Ground Circuit Test	22	Starting Motor Removal and Installation	18

PART 3—ALTERNATOR AND VOLTAGE REGULATOR

Alternator Servicing	31	Regular Servicing	30
Bench Tests	31	Replacing Slip Rings	36
Construction and Operation	27	Service Diagnosis	84
Regular Operation	27	Testing the Alternator	34
Regular Operating Voltage	30	Voltage Regulator	27

PART 4—IGNITION SYSTEM

Breaker and Spring Tension	46	Ignition Timing	41
Distributor Advance	47	Resistance Test	40
Distributor Removal and Installation	41	Secondary Circuit Inspection	35
Dwell Variation	41	Service Diagnosis	85
Idle RPM Test	40	Spark Plugs	48
Ignition Coil	48		

PART 5—ELECTROLUMINESCENT LIGHTING—IMPERIAL

Instrument Testing	49	Service Diagnosis	87
Operation	48		

CONTENTS—(Continued)**PART 5—INSTRUMENTS**

Circuit Breakers.....	55	Fuse Block.....	55
Cluster Bulb Replacement-Chrysler.....	51	Gauge Operation.....	50
Cluster Installation-Chrysler.....	54	Instruments-Imperial.....	51
Cluster Installation-Imperial.....	54	Service Diagnosis.....	87
Cluster Removal-Chrysler.....	51	Switches-Imperial.....	53
Cluster Removal-Imperial.....	52		

PART 6—LIGHTING SYSTEM

Adjusting the Headlamps.....	57	Compensating and Mounting the Aimers.....	56
Aiming the Headlamps.....	56	Dual Headlamps.....	55
Testing Aimer for Calibration.....	57	Readjusting Aimer Calibration.....	57
Testing Headlamp Aim.....	56	Service Diagnosis.....	88

PART 6—DIRECTIONAL INDICATOR SYSTEM

Installation of Switch.....	58	Service Diagnosis.....	88
Removal of Switch.....	59		

PART 7—HORNS

Adjusting.....	59	Testing.....	59
Diagnosis.....	89		

PART 7—WINDSHIELD WIPERS

Assembly of Link (Variable Speed).....	65	Installation of Motor-Imperial.....	65
Assembly of Motor.....	62	Refacing Commutator.....	63
Bench Testing Motor.....	64	Removal of Motor-Chrysler.....	62
Disassembling of Links.....	63	Removal of Motor-Imperial.....	62
Disassembly of Motor.....	62	Service Diagnosis.....	89
End Play Adjustment.....	64	Switch, Variable and Single Speed.....	63
Inspection of Motor.....	63	Undercutting Bakelite.....	64
Installation of Motor-Chrysler.....	64	Wiper Blade Adjustment.....	61

PART 8—POWER SEATS

Drive Unit and Solenoid Assembly.....	68	Removal and Installation of Motor.....	67
Front Seat and Adjuster (Removal and Installation).....	66	Removal and Installation of Slave Unit.....	69
Removal and Installation of Flexible Cables.....	66	Service Diagnosis.....	89

PART 8—ELECTRIC WINDOW LIFTS

Electric Window Lift (Removal and Installation).....	70	Service Diagnosis.....	91
--	----	------------------------	----

PART 8—ELECTRIC DOOR LOCKS

Operation.....	70	Solenoid Removal and Installation.....	70
----------------	----	--	----

CONTENTS— (Continued)
PART 9—WIRING DIAGRAMS

Six Way Seat Adjusting.....	71	Electric Window Lift (Imperial).....	75
Body and Dome Lamp (Except Town and Country) (Chrysler).....	72	Power Vent, Door Locks and Cigar Lighter.....	75
Body and Dome Lamp (Town and Country) (Chrysler).....	73	Engine Compartment (Chrysler).....	76
Body and Dome Lamp (Imperial).....	74	Engine Compartment (Imperial).....	77
Electric Window Lift (Chrysler).....	74	Instrument Panel (Chrysler).....	78
		Instrument Panel (Imperial).....	80

SPECIFICATIONS

BATTERY

Model Usage	TC-1 TC-2	TC-1 TC-2	TC-3 TY-1
	Standard Equipment	Special Equipment	Standard Equipment
Capacity.....	59	70	70
Voltage.....	12	12	12
Number of Plates per Cell.....	11	13	13
Ground Terminal.....	Negative	Negative	Negative
Model			
MoPar Std.....	MB-24-59	MB-27-70	MB-27-70

STARTING MOTOR

	GEAR REDUCTION STARTING MOTOR (All 1963 Passenger Vehicles Except TC1, TC2 with Manual Trans.)	DIRECT DRIVE STARTING MOTOR TC1, TC2 with Manual Transmission
Starting Motor Model.....	2095150	1889200
Make.....	Chrysler Built	Chrysler Built
Voltage.....	12	12
No. of Fields.....	4 (3 Series, 1 Shunt)	4
No. of Poles.....	4	4
Brushes.....	4	4
Spring Tension.....	32 to 48 Ounces	32 to 48 Ounces
Drive.....	Overrunning Clutch	Solenoid Shift—Overrunning Clutch
End Play.....	.010"—.035"	.005" Minimum
Free-Running Test		
Voltage.....	11	11
Amperage Draw Maximum.....	90	78 Amps. Maximum
Speed RPM.....	1925 to 2400	3800 Minimum
Lock-Resistance Test		
Voltage.....	4	4
Amperage Draw.....	400 to 450	350
Solenoid Switch		
Pull-In Coil.....	14.4—16.0 Amps. @ 6.0 Volts	20.0—22.2 Amps. @ 6.0 Volts
Hold-In Coil.....	11.5—12.6 Amps. @ 6.0 Volts	11.2—12.4 Amps. @ 6.0 Volts

SPECIFICATIONS— (Continued)

ALTERNATOR

Rotation.....	Clockwise at Drive End
Voltage.....	12 Volt System
Current Output.....	Design Controlled
Voltage Output.....	Limited by Voltage Regulator
Brushes (Field).....	2
Condenser Capacity.....	.50 Microfarad Plus or minus 20%
Field Current Draw—	
Rotating Rotor by Hand @ 12 Volts.....	2.38 to 2.75 Maximum amperes
Current Output—	
Standard.....	34.5 plus or minus 3 amperes
Special Equip., Heavy Duty and/or Air Conditioning (Both Single and Double Pulleys).....	39 plus or minus 3 amperes

NOTE: Plus or minus three ampere tolerance is provided to allow for temperature variation. Current output is measured at 1250 engine RPM and 15 volts. Voltage is controlled by variable load across the battery such as a carbon pile.

ALTERNATOR VOLTAGE REGULATOR

Alternator Voltage	
Regulator Number.....	2098300
Volts.....	12
Ground Polarity.....	Negative
Point Gap.....	.014 inch plus or minus .002 inch
Air Gap.....	.048 to .052 inch nominal setting

Measure gap with gauge back of stop. Contacts close with .052 inch gauge installed. Contacts open with .048 inch gauge installed.

Temperature in Degrees	70°F.	93°F.	117°F.	140°F.	163°F.
Minimum Setting.....	13.7 to	13.6 to	13.5 to	13.4 to	13.3 to
Maximum Setting.....	14.3	14.2	14.1	14.0	13.9

SPECIFICATIONS

IGNITION SYSTEM

	2095836 (Chrysler Built)	2098690 (Chrysler Built)	
Distributor Part No.....	361, 383 cubic inch	413 cubic inch	
Engine Displacement.....	TC-1, TC-2 (with 2 Bore Carb.)	TC-3, TY-1 (with 4 Bore Carb.)	
Vehicle Model.....			
Advance—Automatic (Distributor Degrees at Distributor rpm).....	0° @ 250 to 450 0 to 2° @ 450 2.5 to 4.5° @ 700 10.5 to 12.5° @ 2150	0° @ 310 to 490 0 to 2° @ 490 3.5 to 5.5° @ 800 8.5 to 10.5° @ 2300	
Advance—Vacuum (Distributor Degrees at inches of Mercury).....	0° @ 4.5" to 8" 6 to 9° @ 12" 11.5 to 14.5° @ 16.5" .014" to .019" 17 to 20 oz. 27° to 32° 10° BTC	0° @ 6" to 9" 4.5 to 7.5° @ 12" 6 to 8.5° @ 13" .014" to .019" 17 to 20 oz. 28° to 33° 10° BTC	
Breaker Point Gap.....	.25 to .285 mfd.	.25 to .285 mfd.	
Dwell Angle.....	.000" to .003"*	.000" to .003"*	
Breaker Arm Spring Tension.....	.003" to .017"	.003" to .017"	
Timing.....	Counter-Clockwise	Counter-Clockwise	
Condenser Capacity.....	J-12Y Champion	J-12Y Champion	
Shaft Side Play.....	14 MM— ³ / ₈ Reach	14 MM— ³ / ₈ Reach	
Shaft End Play (After Assembly).....	.035 inch	.035 inch	
Rotation.....	1-8-4-3-6-5-7-2	1-8-4-3-6-5-7-2	
Spark Plugs.....	Chrysler Auto-Lite Chrysler Essex	Chrysler Auto-Lite Chrysler Essex	
Size.....	1688212 200567 2095223 62-160-2	1688212 200567 2095223 62-160-2	
Gap.....	1.65-1.79 ohms 1.41-1.55 ohms	1.65-1.79 ohms 1.41-1.55 ohms	
Firing Order.....	9400-11700 ohms 9200-10600 ohms	9400-11700 ohms 9200-10600 ohms	
Coil.....	2095501	2095501	
Primary Resistance @ 70-80° F.....	0.5-0.6 ohms	0.5-0.6 ohms	
Secondary Resistance @ 70-80° F.....			
Ballast Resistor.....			
Resistance @ 70-80° F.....			
Current Draw (Coil and Ballast Resistor in Circuit)			
Engine Stopped.....	3.0 Amperes	3.0 Amperes	
Engine Idling.....	1.9 Amperes	1.9 Amperes	

*When distributor is new or after rebuilding (new bushings and/or shaft installed). Service wear tolerance should not exceed .006 inch.

SPECIFICATIONS

IGNITION SYSTEM

Distributor Part No.....	2098620 (Auto-Lite Built)				2098313 (Auto-Lite Built—18S-4011A with Tachometer Drive and Double Breaker)			
	413 cubic inch				413 cubic inch			
Engine Displacement.....	TC2-300 J (with 2—4 Bore Carb.)				TC-1, TC-2 (with 4 Bore Carb.)			
Vehicle Model.....								
Advance—Automatic (Distributor Degrees at Distributor rpm).....	0° @ 525 to 675 0 to 3° @ 675 4.5 to 6.5° @ 910				0° @ 325 to 475 0 to 4.0° @ 475 4.5 to 6.5° @ 640 9 to 11° @ 2400			
Advance—Vacuum (Distributor Degrees at inches of Mercury).....	0° @ 6" to 9" 4.5 to 7.5° @ 12" 7.5 to 10.5° @ 14.3" .014" to .019"				0° @ 7.2" to 8.9" 4.5 to 7.5° @ 12" 7.5 to 10.5° @ 14.5" .014" to .019"			
Breaker Point Gap.....	27° to 32° (one set points) 34° to 40° (both sets points)				27° to 32° (one set Points) 34° to 40° (both sets points)			
Dwell Angle.....	17 to 21.5 oz.				17 to 21.5 oz.			
Breaker Arm Spring Tension.....	15° BTC				10° BTC			
Timing.....	.25 to .285 mfd.				.25 to .285 mfd.			
Condenser Capacity.....	.000" to .003"*				.000" to .003"*			
Shaft Side Play.....	.003" to .017"				.003" to .010"			
Shaft End Play (After Assembly).....	Counter-Clockwise				Counter-Clockwise			
Rotation.....	J-9Y Champion				J-9Y Champion			
Spark Plugs.....	14 MM— $\frac{3}{8}$ Reach				14 MM— $\frac{3}{8}$ Reach			
Size.....	.035 inch				.035 inch			
Gap.....	1-8-4-3-6-5-7-2				1-8-4-3-6-5-7-2			
Firing Order.....	Chrysler	Auto-Lite	Chrysler	Essex	Chrysler	Auto-Lite	Chrysler	Essex
Coil.....	1688212	200567	2095223	62-160-2	1688212	200567	2095223	62-160-2
Primary Resistance @ 70-80° F.....	1.65-1.79 ohms		1.41-1.55 ohms		1.65-1.79 ohms		1.41-1.55 ohms	
	9400-11700 ohms		9200-10600 ohms		9400-11700 ohms		9200-10600 ohms	
Ballast Resistor.....	2095501				2095501			
Resistance @ 70-80° F.....	0.5-0.6 ohms				0.5-0.6 ohms			
Current Draw (Coil and Ballast Resistor in Circuit)								
Engine Stopped.....	3.0 Amperes				3.0 Amperes			
Engine Idling.....	1.9 Amperes				1.9 Amperes			

*When distributor is new or after rebuilding (new bushings and/or shaft installed.) Service wear tolerance should not exceed .006 inch.

BULB CHART

BULB	Chrysler Imperial			
	Chrysler	Imperial		
Sealed Beam—Lo-Beam.....	4002	4002	Map Lamp.....	1004 1004
Sealed Beam—Hi-Beam.....	4001	4001	Ash Receiver.....	53 53
Single Beam 2 filament.....	—	—	Auto Pilot.....	1816 EL. (b)
Tail, Stop & Turn Signal.....	1034	1034	Ignition Switch.....	53 x —
Park & Turn Signal.....	1034	1034	Clock.....	(a) EL. (b)
Back Up Lamps.....	1003	1142	Switch Titles.....	— EL. (b)
License Lamp.....	67	67	Heater and/or A.C. Control P/B.....	57 EL. (b)
Trunk and/or Under Hood Lamp.....	1003	1003	Turn Signal Indicator.....	57 1816
Glove Compartment.....	1891	1891	High Beam Indicator.....	57 1445
Radio.....	53 x	El. (b)	Oil Pressure Indicator.....	57 —
Transmission Control Push Buttons.....	53 x	El. (b)	Instrument Cluster Illumination.....	57
Handbrake Indicator.....	57	257	(a) Included in instrument cluster lighting	
Dome Lamp.....	1004	1004	(b) Electroluminescent	

FUSE CHART

FUSE	Chrysler Imperial			
	Chrysler	Imperial		
Radio.....	7½	7½	Rear Window Defroster.....	15 15
Dome, Stop, Trunk, Park, Tail Lamps....	15	15	Air Cond. or Heater.....	20 20
Cigar lighter, Glove comp. lamp.....	20	20	Rear Air Conditioning.....	20 20
Instrument Panel lamps.....	2	2	All number ratings in amps.	
Back-up lamps.....	Uses windshield wiper switch circuit breaker			

CIRCUIT BREAKER CHART

C/Breaker	Location	Chrysler Imperial			
		Chrysler	Imperial		
Windshield Wiper (Variable Speed)	Back of Wiper Switch	6	6	Elec. Window lifts, Six-Way Seats, Power Vent Windows	Behind left front kick panel — 30
Windshield Wiper (Single Speed)	Integral with Wiper Switch	5	5	Elec. Door Locks	Behind left front kick panel — 20
Lighting System	Integral with Headlamp Switch	15	15	Cigar lighters and Courtesy lamps	Behind left front kick panel — 8
Elec. Window lifts, Six-Way Seat, Top lift	Behind left front kick panel	30	—	All number ratings in amps.	

GROUP 8 ELECTRICAL

BATTERY**1. BATTERY VISUAL INSPECTION**

(1) Protect the fender paint finish with fender covers.

(2) Inspect the battery carrier for damage caused by loss of acid from the battery.

(3) Remove the battery hold-down clamp and clean the top of the battery with clean warm water and paking soda. Scrub areas with a stiff bristle brush being careful not to scatter corrosion residue with the bristles. Finally wipe off with a cloth moistened with ammonia or baking soda in water.

CAUTION: Keep cleaning solution out of battery cells to eliminate weakening the electrolyte.

(4) Inspect the cables. Replace damaged or frayed cables.

(5) Inspect the terminal posts to see that they are not deformed nor broken. Clean the tapered battery terminals and the inside surfaces of the clamp terminals with the terminal cleaning tool, as shown in Figures 1 and 2.

(6) Examine the battery for cracks in the case, and raised cells. Inspect sealing compound for leaks. Reseal as necessary.

(7) Tighten the battery hold-down screw nuts to 3 foot-pounds torque.

(8) Observe the polarity of the terminals of battery to be sure the battery is not reversed and connect the cable clamps to the battery posts and tighten securely. Coat all connections with light mineral grease or petrolatum.

(9) If the electrolyte level is low, fill to the recommended level with mineral-free water.

2. SPECIFIC GRAVITY TEST

A hydrometer is used to measure the specific gravity of the electrolyte in the battery cells. This gives an indication of how much unused sulphuric acid remains in the solution. **Hydrometer floats are calibrated to indicate correctly only at one fixed temperature.**

The specific gravity of the battery electrolyte varies not only with the quantity of acid in solution but also with temperature. Draw electrolyte in and out of the hydrometer barrel several times to bring the temperature of the hydrometer float to that of the acid in the cell and then measure the electrolyte temperature in the cell. The temperature correction amounts

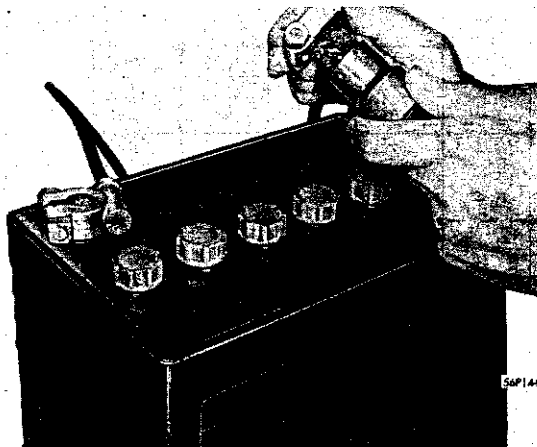

Fig. 1—Cleaning Inside of Cable Clamp

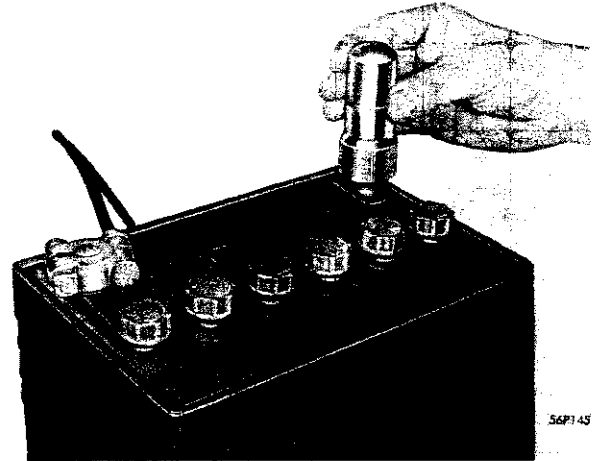

Fig. 2—Cleaning Outside of Battery Post

to .004 specific gravity points for each 10 degrees Fahrenheit change in temperature.

The liquid level of the battery cell should be at normal height and the electrolyte should be thoroughly mixed with any battery water which may have just been added by charging the battery before taking any hydrometer readings. See "Adjustment of Acid Gravity".

A fully charged battery has a specific gravity reading of 1.255 to 1.275 (all batteries for use in temperate climates).

If the battery specific gravity is below 1.220, recharge the battery to a full charge, then proceed with the battery "Voltage Tests" and "Battery Capacity Tests".

3. VOLTAGE TESTS

NOTE: Freshly charged batteries may have a "surface charge" which causes high and inaccurate readings unless properly dissipated. If battery is in the vehicle, turn the headlights on for one to three minutes to remove surface charge. Then turn lights off and wait several minutes before taking another reading.

To make a battery test, contact the meter prods (Tool MT-379) to the proper cell terminals (red to positive, black to negative), using caution not to connect across more than one cell. The point of prod will have to be pushed through sealing compound to make contact with buried link for each cell reading.

The individual cells readings should not vary more than 0.15 volt between any two cells. A battery varying more than 0.15 volt between any two cells should be recharged and "high rate discharge tester" used to test the battery before discarding the battery as unsuitable for use.

CAUTION: Do not use an open flame near the battery.

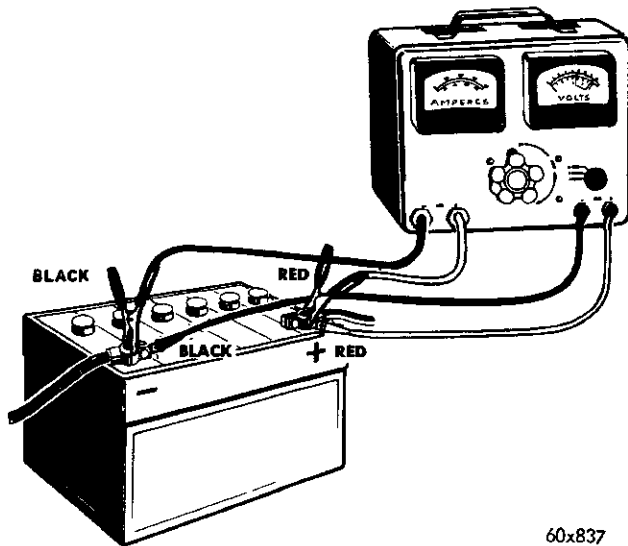

60x837

Fig. 3—High Rate Discharge Test

4. HIGH RATE DISCHARGE TEST OF BATTERY CAPACITY

Satisfactory capacity tests can be made only when battery equals or exceeds 1.220 specific gravity at 80 degrees Fahrenheit. If reading is below 1.220, the battery should be slow charged until fully charged in order to secure proper test results.

- (1) Turn the control knob of the battery starter tester to the OFF position.
- (2) Turn the voltmeter selector switch to the 4

volt position.

(3) Connect the test ammeter and voltmeter positive leads to the battery negative terminal and ammeter and voltmeter negative leads to the battery positive terminal (Fig. 3).

NOTE: The voltmeter clips must contact the battery posts or cable clamps and not the ammeter clips.

(4) Turn the control knob clockwise until ammeter reading is 200 amperes.

(5) Maintain the load for 15 seconds, voltmeter should read 9.5 volts or more, which will indicate battery has good output capacity.

(6) Turn the control knob to the OFF position.

5. CHARGING THE BATTERY

If the voltage in "High Rate Discharge Test" was under 9.5 volt, the battery should be test charged to determine whether the battery can be satisfactorily charged.

Three Minute Charge Test (Fig. 4)

NOTE: This test should not be used if battery temperature is below 60 degrees F.

(1) Connect the positive (+) charger lead to the battery positive terminal and the negative (—) lead to the battery negative terminal.

(2) Trip the power switch to ON position. Turn charger timer switch past "three minutes" then back to "three minutes."

(3) Adjust the charge switch to the highest possible rate not exceeding 40 amperes.

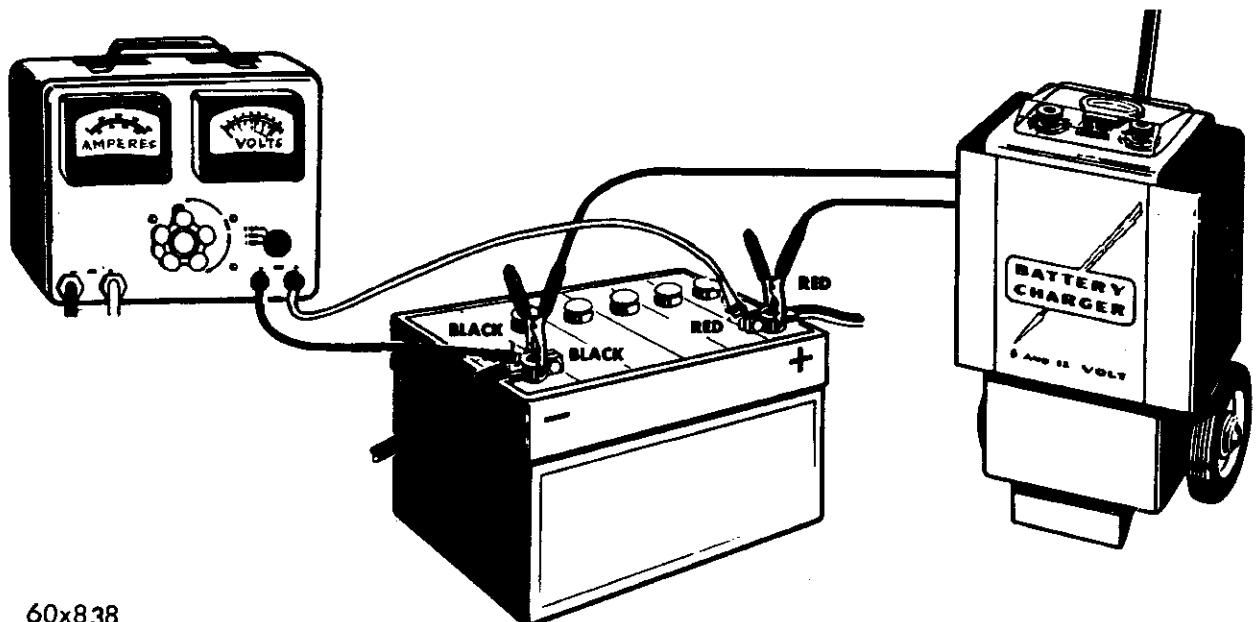

60x838

Fig. 4—Three Minute Charge Test

(4) When the timer switch cuts off at end of 3 minutes, turn back to fast charge.

(5) Use the 4 volt scale of the battery starter tester voltmeter and quickly measure the voltage across each cell while the battery is being fast charged. A faulty cell or cells will be detected by a cell voltage variation of more than .1 volt.

(6) If the cell voltages are even within .1 volt, use 16 volt scale of the battery starter tester and measure the total voltage of the battery posts while the battery is being fast charged. If the total voltage during the charge exceeds 15.5 volts, the battery is sulphated and should be cycled and slow-charged until specific gravity reaches 1.260. (See "Slowing Charging").

If the specific gravity remains constant after testing the battery at one hour intervals for three hours, the battery is at its highest state of charge.

(7) Make another capacity test. If the capacity test does not meet specifications, replace the battery.

NOTE: A slow charge is preferable to bring the battery up to a full charge.

Safe slow charging rates are determined by allowing one ampere per positive plate per cell. The proper slow charging rate would be 6 amperes for a 70 ampere hour battery.

Fast Charging the Battery (Fig. 5)

If adequate time for a slow charge is not available, a high rate (FAST) charge is permissible and will give a sufficient charge in one hour, enabling the battery and alternator to continue to carry the electrical load.

Connect the positive (+) charger lead to the battery positive terminal and the negative (—) charger lead to the battery negative terminal.

CAUTION: The battery can be damaged beyond repair unless the following precautions are taken:

(1) The battery electrolyte temperature must **NEVER** exceed 125 degrees Fahrenheit.

If this temperature is reached, the battery should be cooled by reducing the charging rate or remove the battery from the circuit.

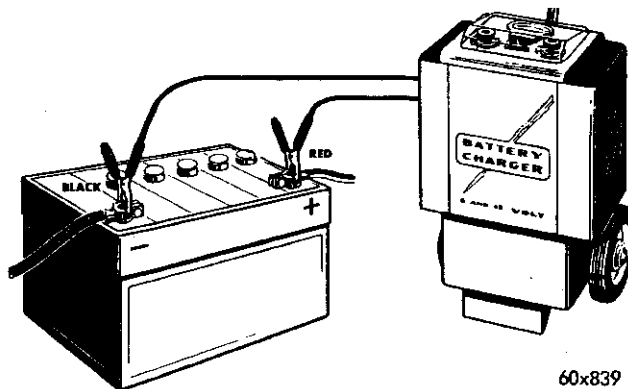

Fig. 5—Fast Charging the Battery

(2) As the batteries approach full charge the electrolyte in each cell will begin to gas or bubble. Excessive gassing must not be allowed.

(3) Do not fast charge longer than one hour.

The battery is fully-charged when three successive hourly hydrometer readings show no rise in specific gravity. Remember to use the temperature correction when checking specific gravity.

If the battery does not show a significant change in the specific gravity after one hour of "FAST" charge, the slow charge method should be used.

NOTE: The manufacturers of high rate charging equipment generally outline the precautions and some models have thermostatic temperature limiting and time limiting controls.

WARNING: When batteries are being charged an explosive gas mixture forms beneath the cover of each cell. Keep all sparks and open flames away from the battery.

Slow Charging Batteries to Remove Sulphation

To condition a battery that is sulphated, charge the battery for a minimum of 24 hours at a maximum charging rate of (4) amperes. As the battery approaches full charge, test the specific gravity at hourly intervals. With no rise in specific gravity for three successive readings, the battery is charged to its peak capacity.

STARTING MOTOR (DIRECT DRIVE)

The Chrysler built Starting Motor (Fig. 6) is a 12-volt, four coil assembly. The starter drive is an over-running clutch type with a solenoid shift type switch mounted on the starting motor.

The brush holders are riveted to a separate brush plate and are not serviced individually. Brush replacement can be made by removing the commutator bearing end head.

6. STARTING MOTOR CIRCUIT TESTS

Insulated Circuit Test

(1) Test the battery electrolyte specific gravity. The specific gravity should be 1.220 or above. If the battery specific gravity is below 1.220, recharge the battery to a full charge before proceeding with the test.

(2) Turn the voltmeter selector switch to the 4 volt position.

(3) Disconnect the ignition coil secondary cable.

(4) Connect the voltmeter positive lead to the battery positive post and the voltmeter negative lead to the solenoid connector which connects to the starter field coils.

NOTE: The voltmeter will read off the scale to the right until the starter is actuated.

(5) Connect the remote control switch to the battery and the solenoid terminal of the starter relay.

(6) Crank the engine with a remote starter control starter switch and observe the voltmeter reading. The voltmeter reading should not exceed .3 volt. A voltmeter reading of .3 volt or less indicates the voltage drop is normal in the cables, starter relay switch, solenoid switch and connections between the battery and the starting motor is normal. See "Starter Ground Circuit Test".

If the voltmeter reading is more than .3 volt, it indicates high resistance in the starter insulated circuit. Make the following test to isolate the point of excessive voltage loss.

(7) Remove the voltmeter lead from the solenoid connector and connect to the following points, repeating the test at each connection. The starter terminal of the solenoid, battery terminal of the solenoid, battery cable terminal at the solenoid, starter

relay and the cable clamp at the battery.

(8) A small change will occur each time a normal portion of the circuit is removed from the test. A definite change in the voltmeter reading indicates that the last part eliminated in the test is at fault.

Maximum allowable voltage loss is as follows:

Battery insulated cable	.2 volt
Solenoid Switch	.1 "
Each connection	.0 "

Replace the faulty cables. Clean and tighten all connections.

Starter Ground Circuit Test

(1) Connect the voltmeter positive lead to the starter housing and the negative voltmeter lead to the battery negative post.

(2) Crank the engine with a remote control starter switch and observe the voltmeter reading. The voltmeter reading should not exceed .2 volt. A reading of .2 volt or less indicates voltage loss in the ground cable and connections are normal. If the voltmeter reading is more than .2 volt, it indicates excessive voltage loss in the starter ground circuit. Make the following tests to isolate the point of excessive voltage loss. Repeating the test at each connection.

- Starter drive housing.
- Cable terminal at the engine
- Cable clamp at the battery.

A small change will occur each time a normal portion of the circuit is removed from the test. A definite change in the voltmeter reading indicates that the last part eliminated in the test is at fault.

Maximum allowable voltage loss is as follows:

Battery ground cable	.2 volt
Engine ground circuit	.1 volt
Each connection	.0 volt

SERVICE PROCEDURES

7. STARTING MOTOR

Removal

- Disconnect the ground cable at the battery.
- Remove the starter cable at the starter.
- Disconnect the solenoid lead wire from the solenoid.
- Remove the bolts attaching the starting motor to the flywheel housing and remove the starting motor and housing removable seal.

8. TESTING THE STARTING MOTOR (BENCH TEST)

Free Running Test

- Place the starter in a vise equipped with soft

jaws and connect a fully-charged, 12 volt battery to the starter.

(2) Connect a test ammeter (100 amperes scale) and carbon pile rheostat in series with the battery positive post and the starter terminal.

(3) Connect the voltmeter (15 volt scale) across the starter.

(4) Rotate the carbon pile to the full-resistance position.

(5) Connect the battery cable from the battery negative post to the starter frame.

(6) Adjust the rheostat until the battery voltage shown on the voltmeter reads 11 volts.

The current draw should be 78 amperes maximum

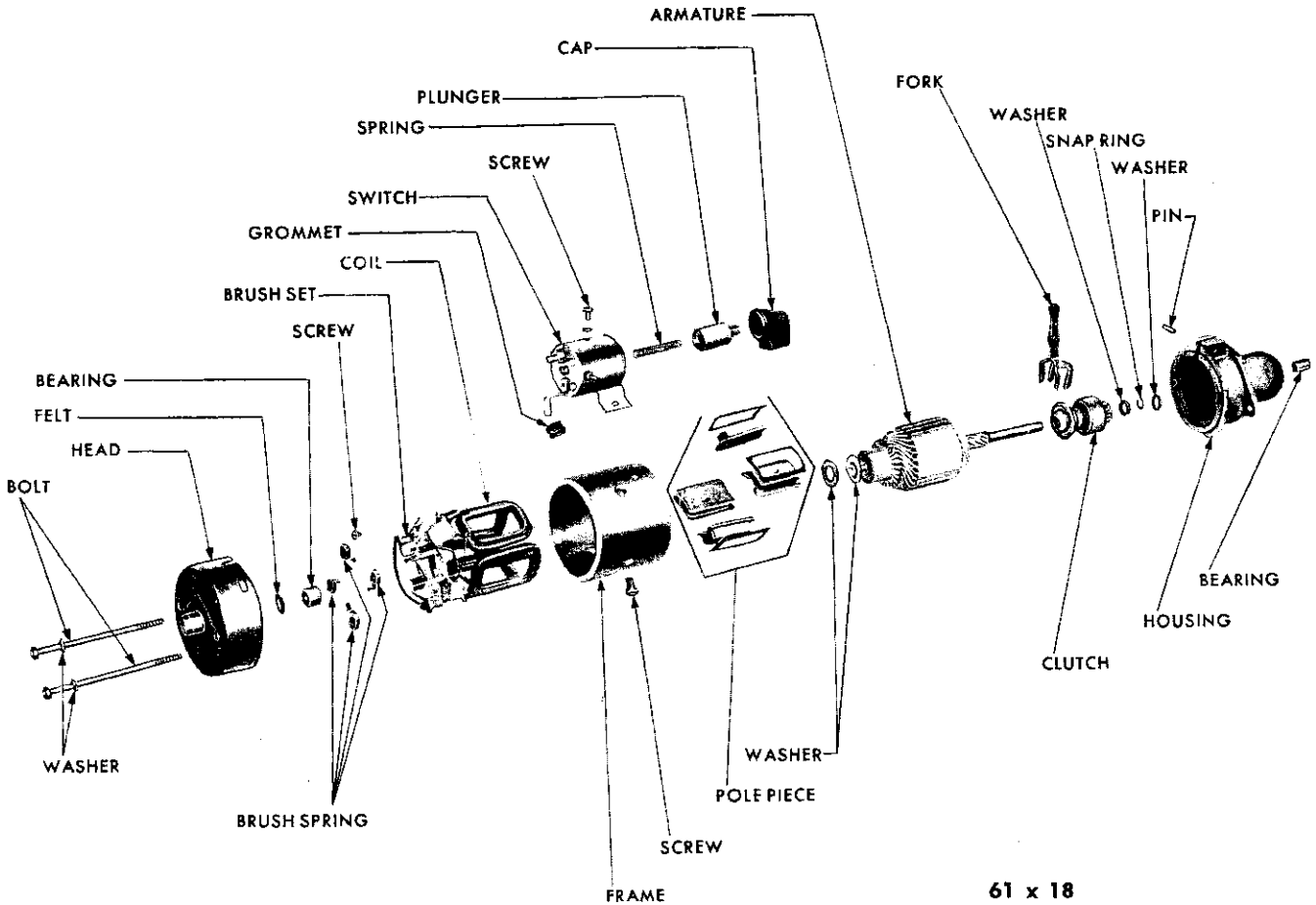

61 x 18

Fig. 6—Starting Motor (Disassembled View)

at 3800 minimum rpm.

Stall Test

- (1) Install the starting motor in the test bench.
- (2) Follow the instructions of the test equipment manufacturer and check the stall torque of the starter against the following specifications.
- (3) With the applied battery voltage adjusted to 4 volts, the stall torque should be 8.5 foot-pounds minimum with a current draw of 350 amperes.

9. STARTER DISASSEMBLY (Fig. 6)

- (1) Remove the through bolts and tap the commutator end head from the field frame.
- (2) Remove the thrust washers from the armature shaft.
- (3) Lift the brush holder springs and remove the brushes from the brush holders.
- (4) Remove the brush plate (Fig. 7).
- (5) Disconnect the field coil leads at the solenoid connector (Fig. 8).

- (6) Remove the solenoid attaching screws and remove the solenoid and boot assembly (Fig. 9).

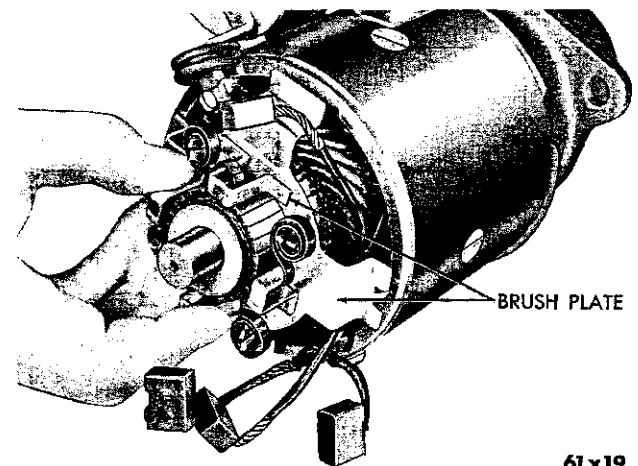

61x19

Fig. 7—Removing the Brush Ring

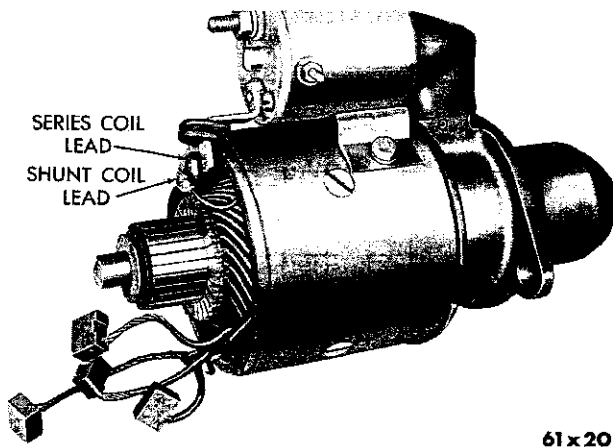

61x20

Fig. 8—Field Coil Leads Disconnected from Solenoid Connector

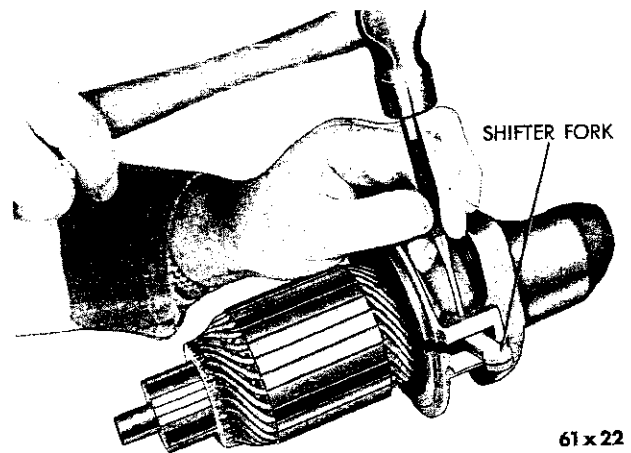

61x22

Fig. 10—Removing or Installing the Shifter Fork Pivot Pin

(7) Drive out the over-running clutch shift fork pivot pin (Fig. 10).

(8) Remove the drive end pinion housing and spacer washer.

(9) Note the position of the shifting fork on the starter and remove the shifter fork (Fig. 11).

(10) Slide the over-running clutch pinion gear toward the commutator end of the armature, drive the stop retainer toward the clutch pinion gear to expose the snap ring and remove the snap ring.

(11) Slide the over-running clutch drive from the armature shaft.

(12) If it is necessary to replace the field coils, remove the ground brushes terminal attaching screw and raise the brushes with the terminal and shunt wire up and away from the field frame (Fig. 12). Remove the pole shoe screws with a special pole shoe impact screwdriver, Tool C-3475.

Cleaning and Inspection

(1) Do not immerse the parts in a cleaning solvent. Immersing the field frame and coil assembly and/or armature will damage the insulation. Wipe these parts with cloth only.

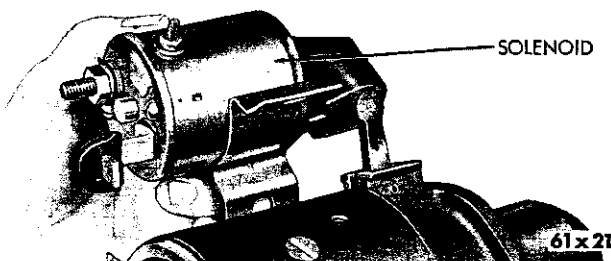

61x21

Fig. 9—Removing or Installing Starter Solenoid

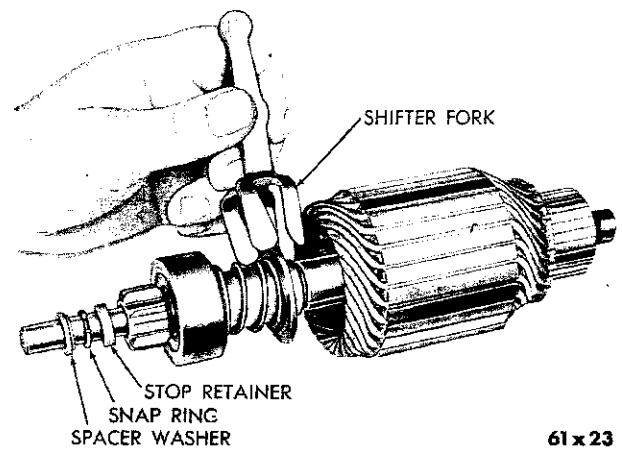

61x23

Fig. 11—Removing or Installing the Shifter Fork

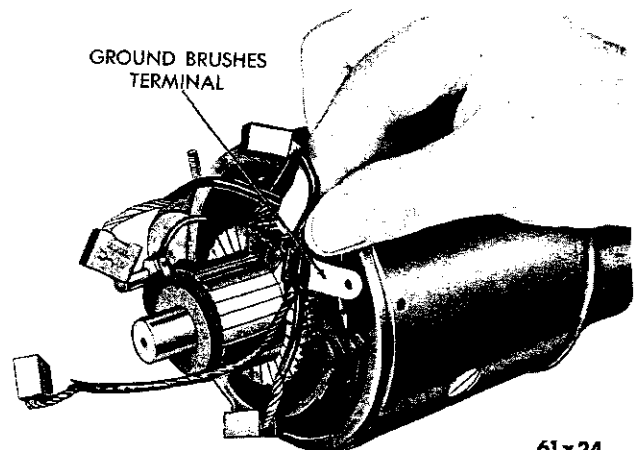

61x24

Fig. 12—Removing or Installing the Ground Brush Terminal

(2) Do not immerse the drive unit in a cleaning solvent. The drive clutch is pre-lubricated at the factory and solvent will wash lubrication from the clutch.

(3) The drive unit may be cleaned with a brush moistened with cleaning solvent and wiped dry with a cloth.

10. BRUSHES AND SPRINGS—REPLACEMENT

(1) The brushes that are worn more than 1/2 the length of the new brush, or are oil-soaked, should be replaced. The brushes and springs can be replaced after removing the commutator end head and the brush plate.

(2) Lift the brushes; disengage the brushes from the brush holders and remove the brush plate.

(3) Disconnect the field lead wires at the solenoid connector (Fig. 8).

(4) Remove the screw attaching the ground brush terminal to the field frame and raise the brushes and terminal up and away from the field frame (Fig. 12).

NOTE: The leads are not equal in length. Inspect the brush leads before cutting, to insure the proper length at installation.

(5) Clip the brush leads at the ground terminal and at the field coils.

(6) Open the brush lead retaining clips to remove the old brush leads.

(7) When resoldering the brush leads, make a strong, low resistance connection using a high temperature solder and resin flux. Do not use acid. Do not break the shunt wire when removing the installing the ground brushes.

(8) The brush springs can be removed by spreading the retainers and disengaging the springs from the

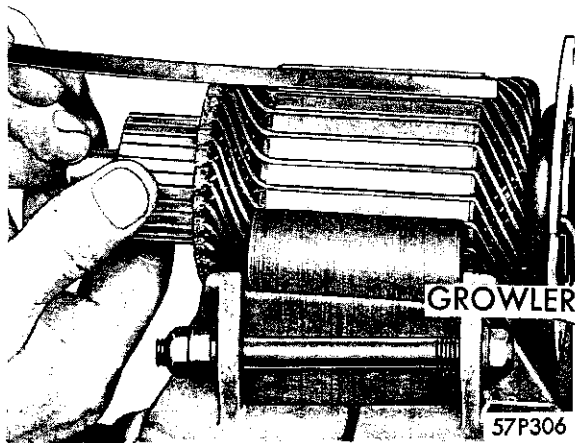

Fig. 13—Testing Armature for Short

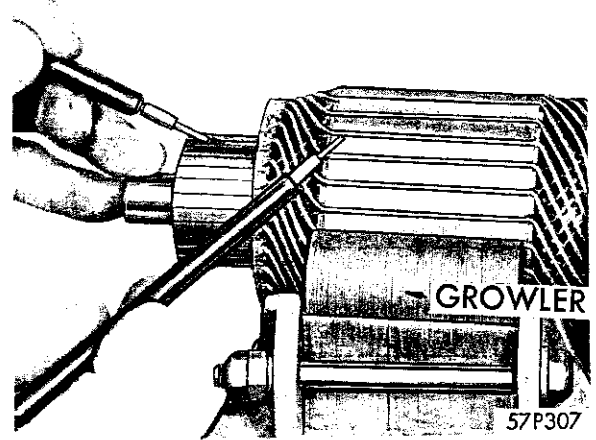

Fig. 14—Testing Armature for Ground

retainer legs.

(9) Measure the brush spring tension with a spring scale hooked under the spring near the end. Pull the scale on a line parallel to the edge of the brush and take a reading just as the spring end leaves the brush. The spring tension should be 32 to 48 ounces. Replace the springs that do not meet specifications.

11. TESTING THE ARMATURE

Testing the Armature for Short Circuit

Place the armature in the growler (Fig. 13) and hold a thin steel blade parallel to the core and just above it, while slowly rotating the armature in the growler. A shorted armature will cause the blade to vibrate and be attracted to the core. Replace a shorted armature.

Testing Armature for Ground

Touch the armature shaft and end of a commutator bar with a pair of test lamp test prods (Fig. 14). If the lamp lights, it indicates a grounded armature. Replace the grounded armature.

Testing Commutator Runout, Refacing and Undercutting

Place the armature in a pair of "V" blocks and measure the runout with a dial indicator. Test both the shaft and the commutator. A bent shaft requires replacement of the armature. When the commutator runout exceeds .003 inch, the commutator should be refaced. Remove only sufficient metal to provide a smooth, even surface.

12. TESTING THE FIELD COILS FOR GROUND

(1) Remove the through bolts and remove the commutator end frame.

(2) Remove the brushes from the brush holders

and remove the brush ring (Fig. 7).

(3) Disconnect the field lead wires at the solenoid connector and separate the field leads to make sure they do not touch the solenoid connector (Fig. 8).

(4) Remove the ground brushes attaching screw and raise the brushes with the terminal and shunt wire up and away from the field frame (Fig. 12).

(5) Touch one probe of the test lamp to the series field coil lead and the other probe to the field frame (Fig. 15). The lamp should not light.

(6) Touch one probe to the shunt field coil lead and the other probe to the field frame (Fig. 16).

If the lamp lights in either test steps (5) or (6), the field coils are grounded. If the field coils are grounded, test each coil separately after unsoldering the connector wires. Replace the grounded field coils.

(7) Touch each of the brush holders with one test probe, while holding the other test probe against the brush ring. Two brush holders that are 180 degrees apart should cause the test lamp to light as they are intentionally grounded. The other two brush holders (Fig. 17) should not cause the lamp to light when tested, as they are insulated. If the insulated brush holders cause the lamp to light when tested, it indicates that the brush holders on the brush ring are grounded. Replace the brush ring assembly if the brush holders are grounded.

13. REPLACING THE FIELD COILS

A pole shoe impact screwdriver Tool C-3475 should be used to remove and install the field coils to prevent damage to the pole shoe screws and for proper tightening. The pole shoes that are loose and not properly seated may cause the armature core to rub the pole shoes. This will decrease the starter efficiency and damage the armature core.

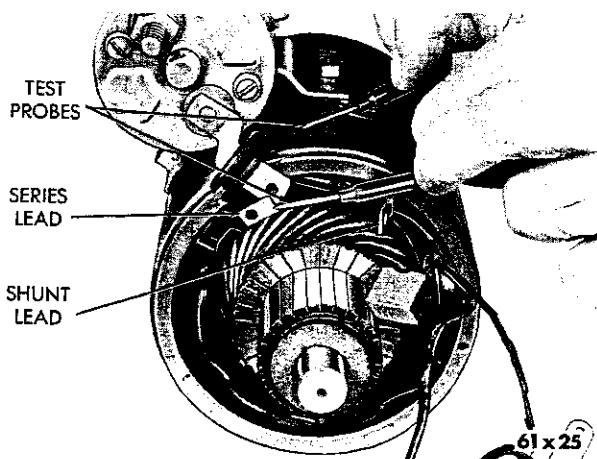

Fig. 15—Testing Series Coil for Ground

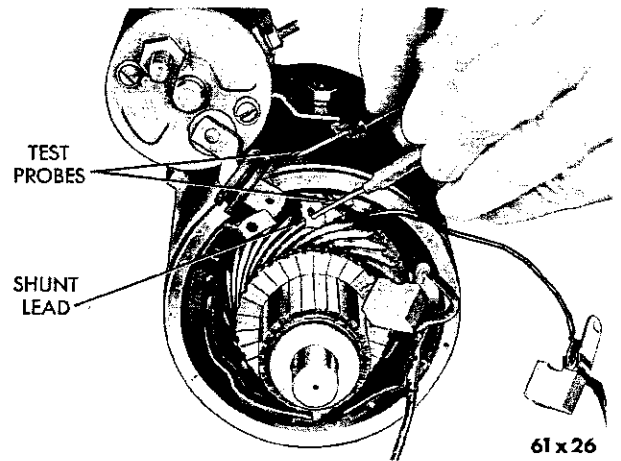

Fig. 16—Testing Shunt Coil for Ground

14. SERVICING THE BRUSHES

Inspect the armature shaft bearing surfaces and bushings for wear by placing the armature core in a vise equipped with soft jaws. Do not squeeze tightly. Try the commutator end frame, the drive end frame, and armature support bushings for wear by placing them on shafts and inspecting for side play. Replace the commutator end frame and bushing assembly if the bushing is worn, also, replace the drive end bushing if it is worn. The bushing should be well soaked in SAE 30W engine oil before it is installed.

15. SERVICING THE DRIVE UNIT

Place the drive unit on the shaft and, while holding the armature, rotate the drive pinion. The drive pinion should rotate smoothly in one direction (not necessarily easily), but should not rotate in the opposite direction. If the drive unit does not function

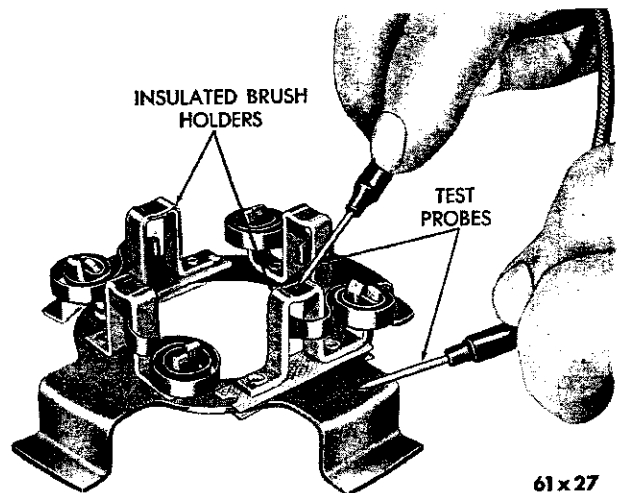

Fig. 17—Testing Insulated Brush Holders for Ground

properly, or the pinion is worn or burred, replace the drive unit.

16. STARTER ASSEMBLY (Fig. 6)

(1) Lubricate the armature shaft and splines with SAE 10W oil or 30W rust preventive oil.

(2) Install the starter drive, stop collar (retainer), the lock ring and the spacer washer.

(3) Install the shifter fork over the starter drive spring retainer washer with the narrow leg of fork toward commutator (Fig. 11). This is important, if the fork is not properly positioned, the starter gear travel will be restricted causing a lockup in the clutch mechanism.

(4) Install the drive end (pinion) housing on the armature shaft, indexing the shifting fork with the slot in the drive end of the housing.

(5) Install the shifter fork pivot pin (Fig. 10).

(6) Install the armature with the clutch drive, shifter fork, and pinion housing; slide the armature into the field frame until the pinion housing indexes with the slot in the field frame.

(7) Install the solenoid and boot assembly (Fig. 9). Tighten bolts to 60 to 70 inch-pounds torque.

(8) Install the ground brushes (Fig. 12).

(9) Connect the field coil leads at the solenoid connector (Fig. 8).

(10) Install the brush holder ring (Fig. 7) indexing the tang of the ring in the hole of the field frame.

(11) Position the brushes in the brush holders. Be sure the field coil lead wires are properly enclosed behind the brush holder ring and that they do not interfere with the brush operation.

(12) Install the thrust washers on the commutator end of the armature shaft to obtain .010 inch minimum end play.

(13) Install the commutator end head.

(14) Install the through bolts and tighten 40 to 50 inch-pounds torque.

17. ADJUSTING STARTER DRIVE GEAR (PINION) CLEARANCE

(1) Place the starter assembly in a vise equipped with soft jaws and tighten the vise sufficiently to hold the starter.

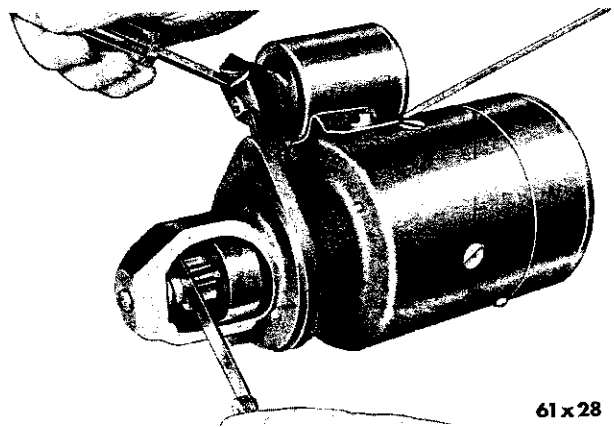

Fig. 18—Measuring Starter Drive Pinion Clearance

NOTE: Place a wedge or screwdriver between the bottom of the solenoid and the starter frame to eliminate all deflection in the solenoid when making the pinion clearance check. (Fig. 18).

(2) Push in on the solenoid plunger link (Fig. 18) (NOT THE FORK LEVER) until the plunger bottoms.

(3) Measure the clearance between the end of the pinion and pin stop with plunger seated and pinion pushed toward the commutator end. The clearance should be $\frac{1}{8}$ inch. Adjust for proper clearance by loosening the solenoid attaching screws and move the solenoid fore and aft as required.

(4) Test the starter operation under a free running test Paragraph 8.

18. STARTER INSTALLATION

(1) Before installing the starter, be sure the starter and flywheel housing mounting surfaces are free of dirt and oil. These surfaces must be clean to make good electrical contact.

(2) Position the starter to the flywheel housing removable seal.

(3) Install the starter from beneath the engine.

(4) Tighten the attaching bolts securely.

(5) Attach the wires to the solenoid switch and the starter terminal.

(6) Install the battery ground cable and test operation of the starter for proper engine cranking.

PART 2

STARTING MOTOR (REDUCTION GEAR TYPE)

The reduction-gear starting motor has an armature-to-engine crankshaft ratio of 45 to 1: a 3.5 to 1 reduction gear set is built into the motor assembly, which is housed in an aluminum die casting (Fig.

19). The starting motor utilizes a solenoid shift device, the housing of the solenoid is integral with the starting motor drive end housing.

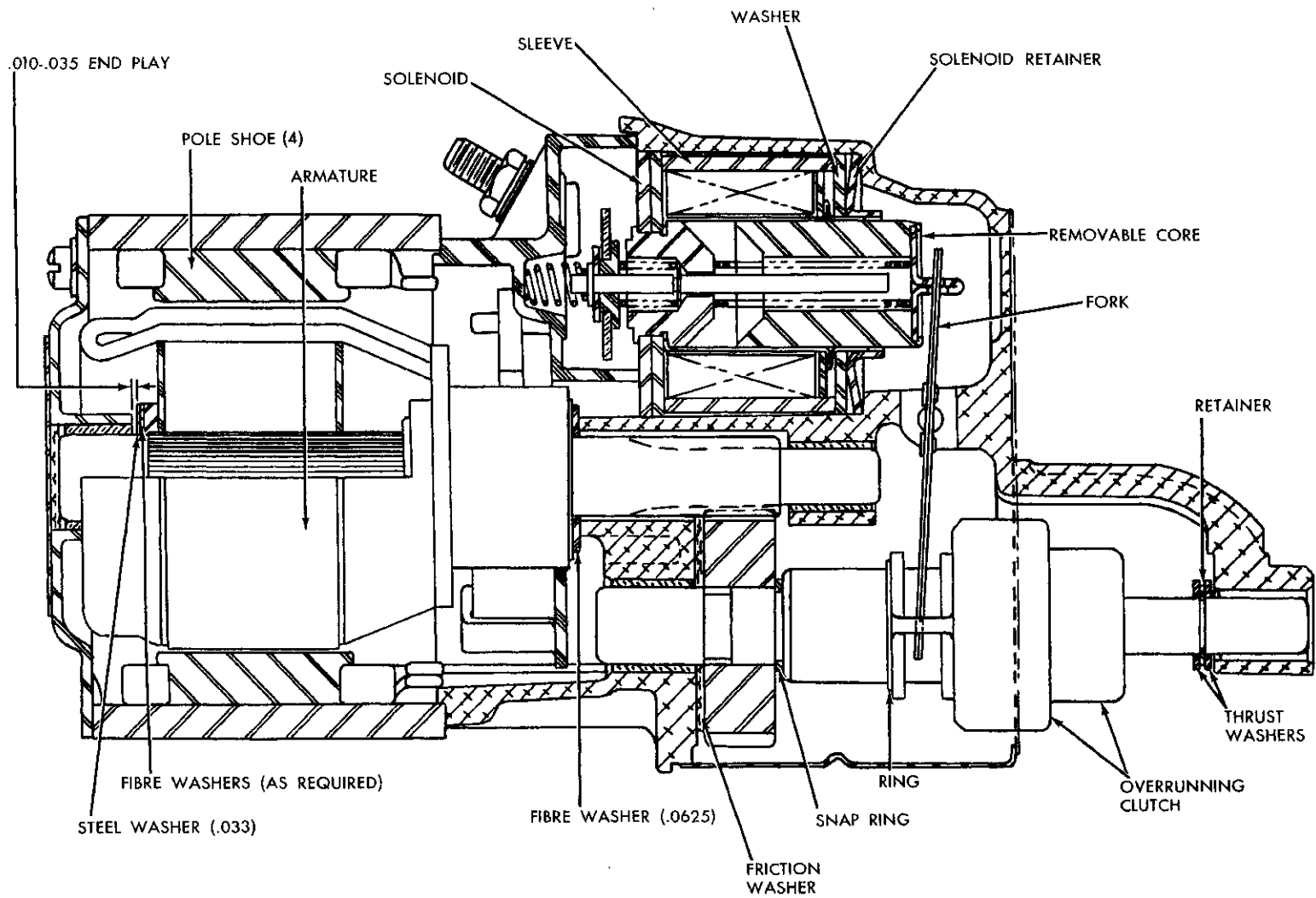

Fig. 19—Starting Motor Cross Section

62x219

19. TESTING STARTER RESISTANCE AND CURRENT DRAW

(1) Test the battery electrolyte specific gravity. Specific gravity should be 1.220 or above. If the battery specific gravity is below 1.220, recharge the battery to full charge before proceeding with the test.

(2) Disconnect the positive battery lead from the battery terminal post. Connect an 0 to 300 scale ammeter between the disconnected lead and the battery terminal post.

(3) Connect a test voltmeter with 10 volt scale division between the battery positive post and the starter switch terminal at the starter solenoid.

(4) Crank the engine and observe the readings on the voltmeter and ammeter. The voltage should not exceed .3 volt. A reading of voltage that exceeds .3 volt indicates there is high resistance caused from loose circuit connections, a faulty cable, burned starter relay or solenoid switch contacts. A current that is high and is combined with slow cranking speed, indicates that the starter should be removed and repaired.

20. STARTER GROUND CIRCUIT TEST

(1) Connect the voltmeter positive lead to the starter housing and the negative voltmeter lead to the battery negative post.

(2) Crank the engine with a remote control starter switch and observe the voltmeter reading. The voltmeter reading should not exceed .3 volt. A reading of .3 volt or less indicates voltage in the ground cable and connections is normal. If the voltmeter reading is more than .3 volt, it indicates excessive voltage loss in the starter ground circuit. Make the following tests to isolate the point of excessive voltage loss. Repeating the test at each connection.

- (a) Starter drive housing.
- (b) Cable terminal at the engine.
- (c) Cable clamp at the battery.

A small change will occur each time a normal portion of the circuit is removed from the test. A definite change in the voltmeter reading indicates that the last part eliminated in the test is at fault.

Maximum allowable voltage loss is as follows:

Battery ground cable	.2 volt
Engine ground circuit	.1 volt
Each connection	.0 volt

SERVICE PROCEDURES

21. STARTING MOTOR

Removal

- (1) Disconnect the ground cable at battery.
- (2) Remove the cable at the starter.
- (3) Disconnect the solenoid lead wire at the solenoid terminals.
- (4) Remove the one stud nut and one bolt attaching the starter motor to the flywheel housing and remove the starting motor, housing and removable seal.

22. TESTING THE STARTING MOTOR (BENCH TEST)

Free Running Test

Disassembly

- (1) Place the gear housing of the starter in a vise equipped with soft jaws. Use the vise as a support fixture only. **DO NOT** clamp.
- (2) Remove the two through bolts and the starter end head assembly.
- (3) Carefully pull the armature up and out of the gear housing, and the starter frame and field assembly. Remove the steel and fiber thrust washer.

NOTE: The wire of the shunt field coil is soldered to the brush terminal. One pair of brushes are con-

nected to this terminal. The other pair of brushes is attached to the series field coils by means of a terminal screw. Carefully pull the frame and field assembly up just enough to expose the terminal screw and the solder connection of the shunt field at the brush terminal. Place two wood blocks between the starter frame and starter gear housing (Fig. 20) to facilitate removal of the terminal screw and the unsoldering of the shunt field wire at the brush terminal.

(1) Place the starter in a vise and connect a fully-charged, 12 volt battery to the starter as follows:

(2) Connect a test ammeter (100 amperes scale) and carbon pile rheostat in series with the battery positive post and the starter terminal.

(3) Connect a voltmeter (15 volt scale) across the starter.

(4) Rotate the carbon pile to a full-resistance position.

(5) Connect the battery cable from the battery negative post to the starter frame.

(6) Adjust the rheostat until the battery voltage shown on the voltmeter reads 11 volts.

(7) The amperage draw should be as shown in the specifications.

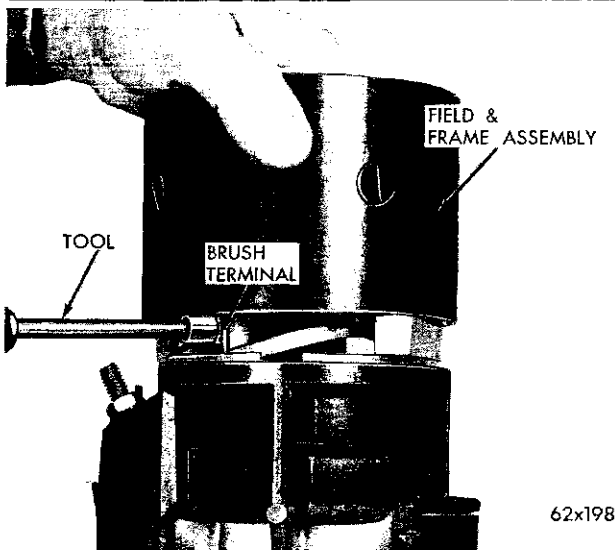

Fig. 20—Removing or Installing Brush Terminal Screw

Locked Resistance Test

- (1) Install the starter in a test bench.
- (2) Follow the instructions of the test equipment manufacturer and test the locked resistance of the starter against the following specifications.
- (3) With applied battery voltage adjusted to 4 volts, the amperage draw should be as shown in specifications.
- (4) Support the brush terminal by placing a finger behind the terminal and remove the terminal screw (Fig. 20).
- (5) Unsolder the shunt field coil lead from the starter brush terminal (Fig. 21).
- (6) Remove the brush insulator which prevents contact between the brush terminal and the gear housing (Fig. 22).

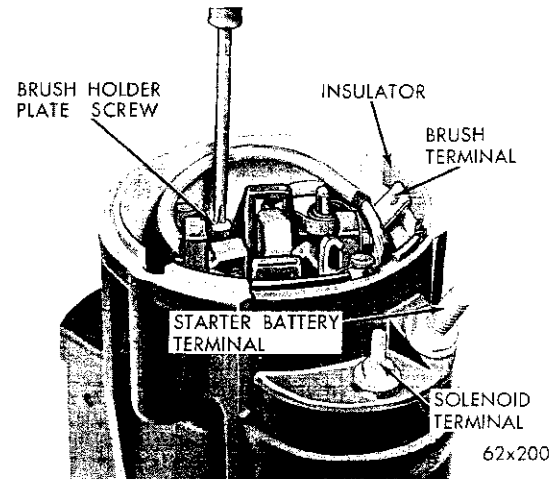

Fig. 22—Removing or Installing Brush Holder Plate Screw

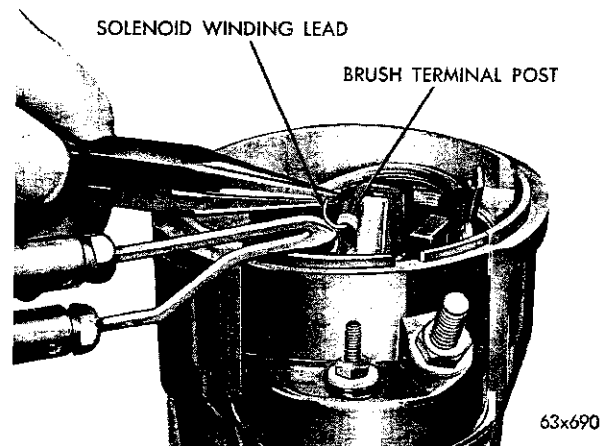

Fig. 23—Unsoldering Solenoid Winding Head

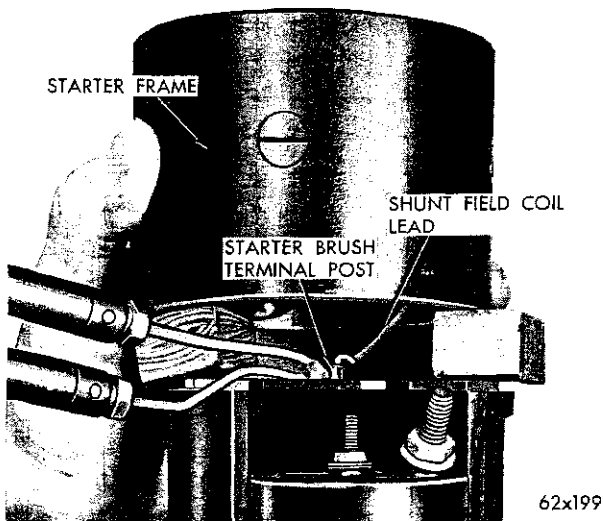

Fig. 21—Unsoldering Shunt Coil Lead Wire

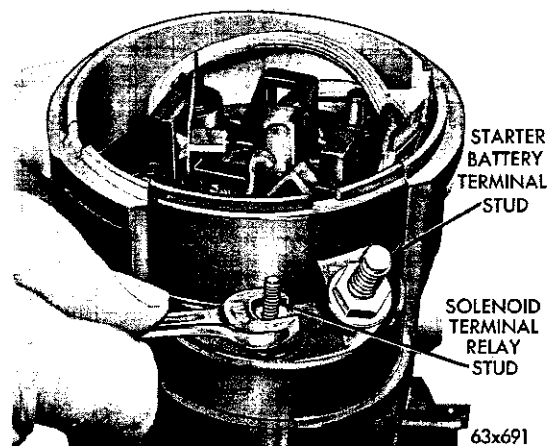

Fig. 24—Removing Solenoid Terminal Nut

8-20 ELECTRICAL

NOTE: The brush holder plate with the brush terminal, contact and brushes is serviced as an assembly.

- (7) Remove the sealer at the brush holder plate and gear housing.
- (8) Remove the screw attaching the brush holder plate to the starter gear housing (Fig. 22).
- (9) Unsolder the solenoid winding from the starter brush terminal (Fig. 23).
- (10) Remove nut ($1\frac{1}{2}$ wrench), steel washer and insulating washer from the solenoid terminal (Fig. 24).
- (11) Straighten the solenoid wire and remove the brush holder plate with brushes as an assembly.
- (12) Remove the ground screw from the starter gear housing.
- (13) Remove the solenoid assembly from the gear housing well (Fig. 25).
- (14) Remove the nut, steel washer and sealing

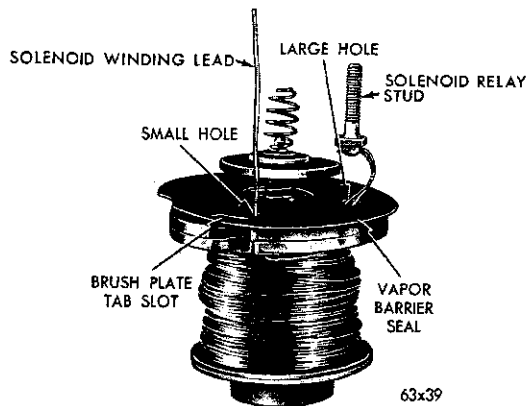

Fig. 25—Solenoid Assembly Removed

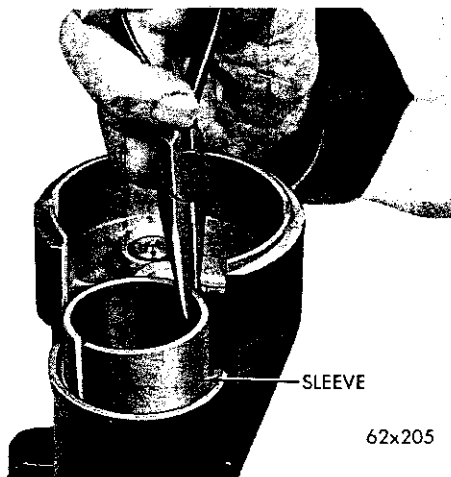

Fig. 26—Removing Solenoid Coil Sleeve

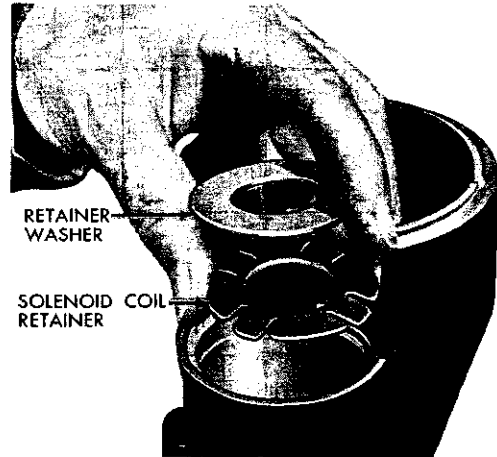

Fig. 27—Identification of Solenoid Coil Retainer and Retainer Washer

washer from starter battery terminal.

- (15) Remove the starter battery terminal from the holder plate.
- (16) Remove the solenoid contact and plunger assembly from the solenoid.

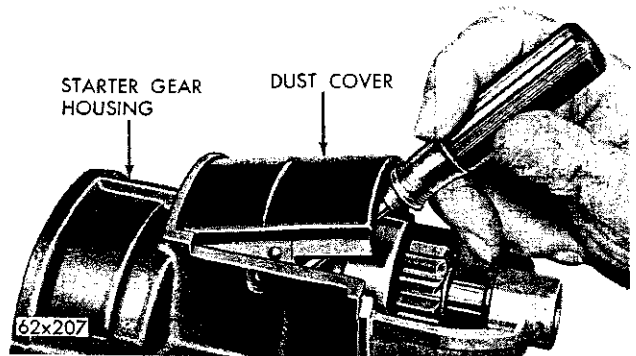

Fig. 28—Removing Dust Cover

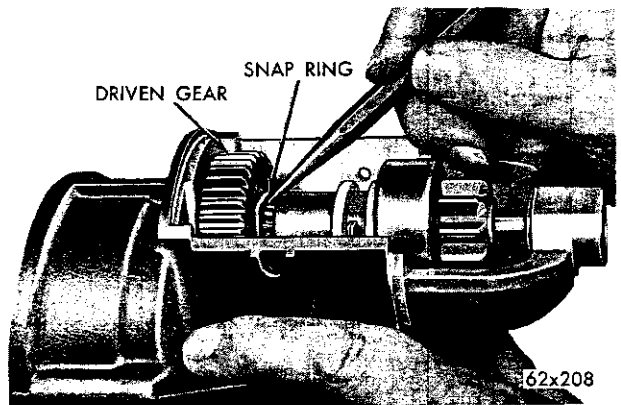

Fig. 29—Removing Driven Gear Snap Ring

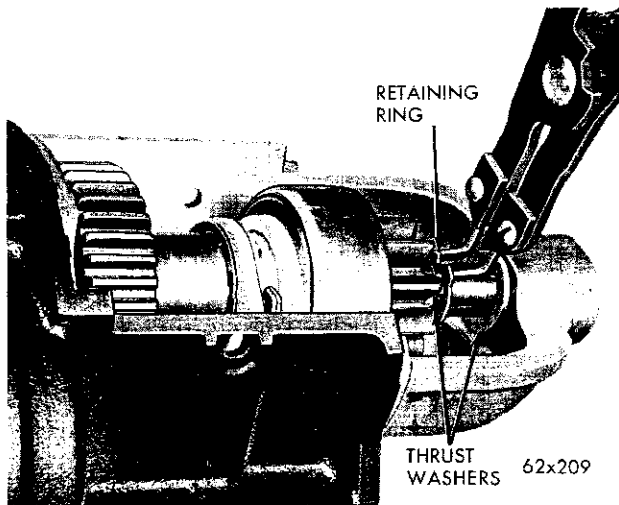

Fig. 30—Removing or Installing Pinion Shaft Retainer Ring

- (17) Remove the solenoid coil sleeve (Fig. 26).
 - (18) Remove the solenoid return spring from the well of the solenoid housing moving core.
 - (19) Remove the solenoid coil retainer washer and solenoid coil retainer from the solenoid housing (Fig. 27).
 - (20) Remove the dust cover from the gear housing (Fig. 28).
 - (21) Release the snap ring that positions the driven gear on the pinion shaft (Fig. 29).
- CAUTION:** The ring is under tension and a cloth should be placed over the ring to prevent the ring from springing away after removal.
- (22) Release the retainer ring at the front of the pinion shaft (Fig. 30).

NOTE: Do not spread the retainer ring any greater than the outside diameter of the pinion shaft otherwise the lock ring can be damaged.

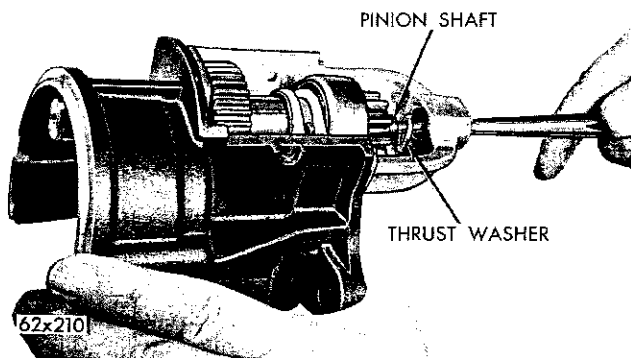

Fig. 31—Removing Pinion Shaft

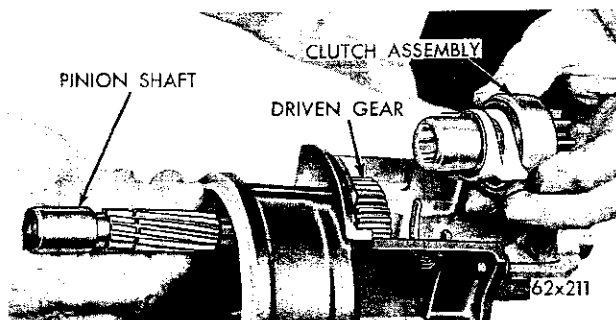

Fig. 32—Removing or Installing Clutch Assembly

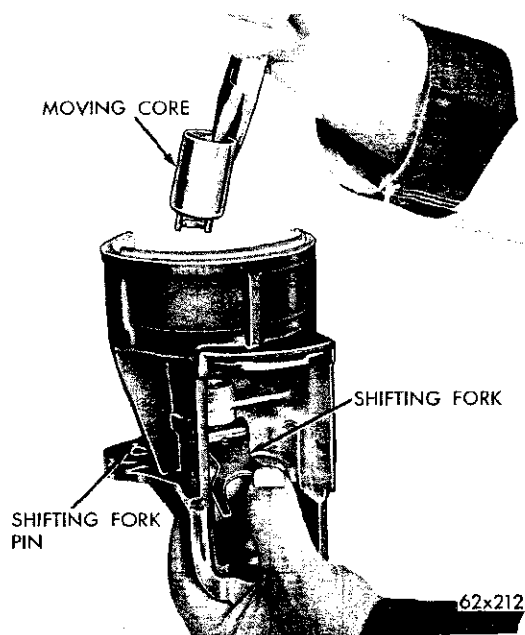

Fig. 33—Removing or Installing Moving Core

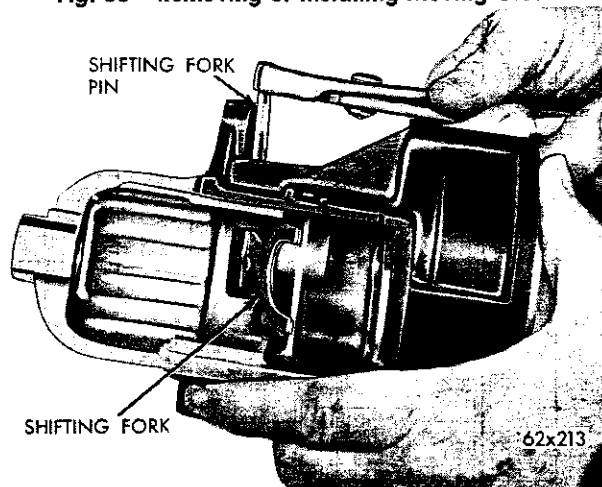

Fig. 34—Removing Shifting Fork Pin

(23) Push the pinion shaft towards the rear of the housing (Fig. 30) and remove the snap ring and thrust washers, clutch and pinion assembly, with the two shifter fork nylon actuators (Fig. 32).

(24) Remove the driven gear and friction washer.

(25) Pull the shifting fork forward and remove the solenoid moving core (Fig. 33).

(26) Remove the shifting fork retainer pin (Fig. 34) and remove the clutch shifting fork assembly.

NOTE: The gear housing is serviced with the pinion shaft and armature shaft bushings as an assembly.

Cleaning and Inspection

(1) Do not immerse the parts in cleaning solvent. Immersing the field frame and coil assembly and/or armature will damage the insulation. Wipe these parts with a clean cloth **only**.

(2) Do not immerse the clutch unit in cleaning solvent. The clutch is pre-lubricated at the factory and solvent will wash the lubrication from the clutch.

(3) The starter clutch outer housing and pinion gear may be cleaned with a cloth moistened with cleaning solvent and wiped dry with a clean dry cloth.

(4) Unsolder the solenoid lead wires from the solenoid terminal relay stud.

(5) Clean all corrosion from the solenoid assembly (washers, sleeve and retainer and inside of the solenoid housing). These metal parts are part of the solenoid hold-in coil ground circuit and must be clean.

(6) Clean the terminal contacts and contractor with crocus cloth.

(7) Thoroughly clean the outside area of the brush plate to remove all oil and dirt.

23. REPLACEMENT OF BRUSHES AND SPRINGS

(1) Brushes that are worn more than $\frac{1}{2}$ the length of the new brushes, or are oil-soaked, should be replaced.

(2) When resoldering the shunt field and solenoid lead, make a strong, low resistance connection using a high temperature solder and resin flux. **Do not use acid nor acid core solder. Do not break the shunt field wire when removing and installing the brushes.**

(3) Measure the brush spring tension with a spring scale hooked under the spring near the end. Pull the scale on a line parallel to the edge of the brush and take a reading just as the spring end leaves the brush. The spring tension should be 32 to 48 ounces. Replace the springs that do not meet specifications.

24. TESTING THE ARMATURE

Testing the Armature for Short Circuit

Place the armature in the growler and hold a thin

steel blade parallel to the core and just above it, while slowly rotating the armature in the growler. A shorted armature will cause the blade to vibrate and be attracted to the core. Replace any armature that is shorted.

Testing Armature for Ground

Contact the armature shaft and each of the commutator riser bars with a pair of test lamp test prods. If the lamp lights, it indicates a grounded armature. Replace any grounded armature.

Testing Commutator Runout, Refacing and Undercutting

Place the armature in pair of "V" blocks and measure the runout with a dial indicator; measure both the shaft and the commutator. A bent shaft requires replacement of the armature. When the commutator runout exceeds .003 inch, the commutator should be refaced and undercut using Tool C-770. Remove only sufficient metal to provide a smooth, even surface.

Testing Field Coils for Ground

(1) Remove the field frame assembly from the starter.

(2) Carefully drill out the rivet that attaches the series field coil (ground) lead and shunt field coil lead to the field frame.

(3) Insulate the field coil leads from the field frame.

(4) Test for ground using a 110 volt test lamp. Touch one prod of test lamp to series field coil lead and other prod to the field frame. The lamp should not light. Repeat procedure for the shunt field coil.

If the lamp lights, it indicates that the field coils are grounded and require replacement.

25. REPLACING THE FIELD COILS

A pole shoe impact screwdriver Tool C-3475 should be used to remove and install the field coils to prevent damage to the pole shoe screws and for proper tightening. The pole shoes that are loose and not properly seated may cause the armature core to rub the pole shoes. This will decrease starter efficiency and damage the armature core.

NOTE: Make sure the area between the leads and the field frame is clean. Peen a new rivet securely to insure a good electrical contact.

26. TESTING THE BRUSHES FOR WEAR

Inspect the armature shaft bearing and pinion shaft surfaces and bushings for wear. Try the bushings for wear by placing them on shafts and testing for side play. Replace the commutator end head and bushing assembly if the bushing is worn. Replace the starter gear housing if the bushings are worn.

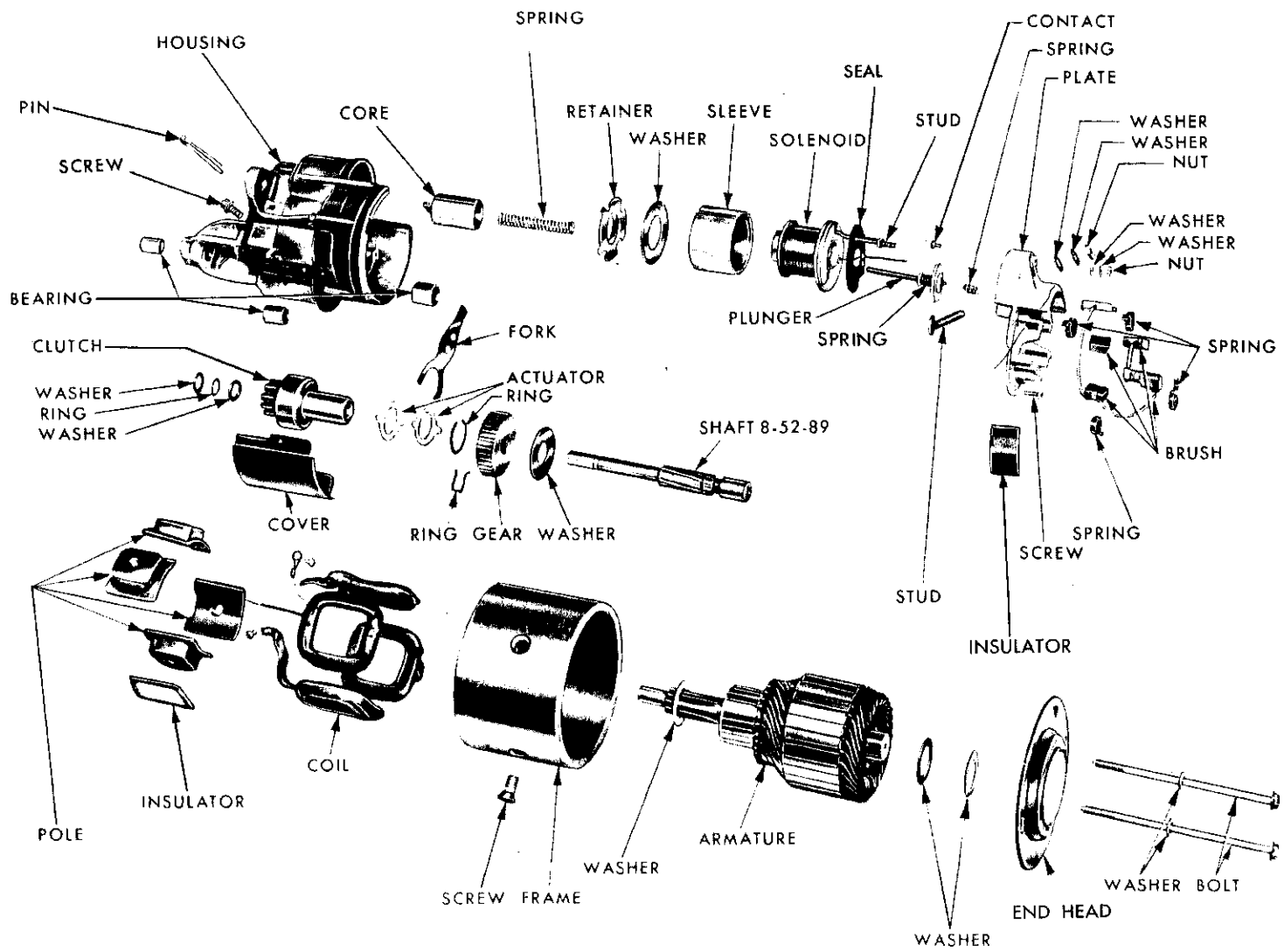

Fig. 35—Starter Motor (Exploded View)

62x543A

27. SERVICING THE STARTER CLUTCH UNIT

Do not immerse the starter clutch unit in a cleaning solvent. The starter clutch is pre-lubricated at the factory and the solvent will wash the lubrication from the clutch.

The starter clutch outer housing and pinion gear may be cleaned with a cloth moistened with cleaning solvent and wiped dry with a clean dry cloth.

Rotate the pinion. The pinion gear should rotate smoothly in one direction, but should not rotate in the opposite direction. If the starter clutch unit does not function properly, or the pinion is worn, chipped or burred, replace the starter clutch unit.

Assembly (Fig. 35)

NOTE: The shifter fork consists of two spring steel plates assembled with two rivets (Fig. 36). There should be approximately 1/16 inch side movement, as shown in Figure 36 to insure proper pinion gear engagement. Lubricate between the plates sparingly with SAE 10 engine oil.

(1) Position the shifter fork in the drive housing and install the shifting fork retainer pin (Fig. 34). One tip of pin should be straight, the other tip should be bent at a 15 degree angle away from the housing. Fork and retainer pin should operate freely after bending the tip of pin.

(2) Install the solenoid moving core and engage the shifting fork (Fig. 33).

(3) Enter the pinion shaft into the drive housing, and install the friction washer and driven gear.

(4) Install the clutch and pinion assembly. (Fig. 32), thrust washer, retaining ring and the thrust washer.

(5) Complete the installation of the pinion shaft engaging the shifting fork with the clutch actuators. Figure 37 shows the correct relation of the parts at the assembly.

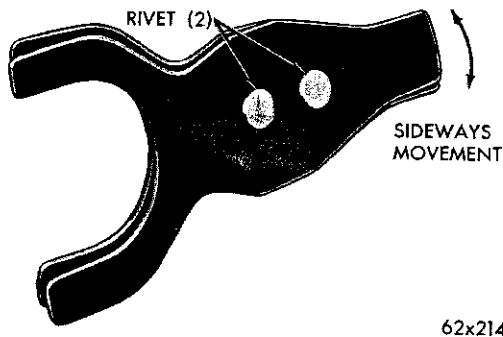

Fig. 36—Shifter Fork Assembly

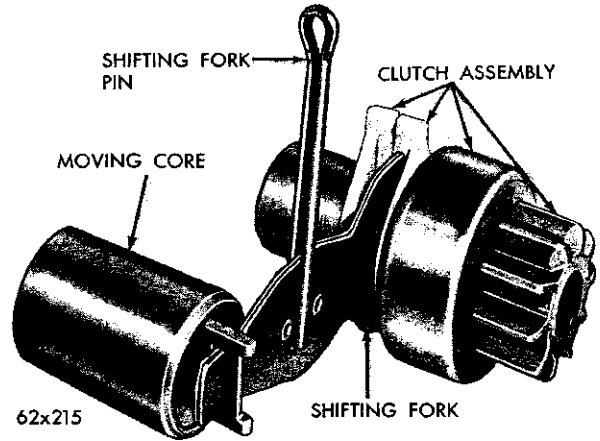

Fig. 37—Shifter Fork and Clutch Arrangement

NOTE: The friction washer must be positioned on the shoulder of the splines of the pinion shaft before the driven gear is positioned.

(6) Install the driven gear snap ring (Fig. 29).

(7) Install the pinion shaft retaining ring (Fig. 30). Make sure the ring fits tightly in the shaft groove.

(8) Bend the four (4) tangs of the coil retainer "up" to a measurement of $\frac{5}{32}$ " to $\frac{3}{16}$ " above the surface of the retainer (Fig. 38) to insure higher compression and a more positive ground.

(9) Install the solenoid coil retainer (Fig. 27) (with tangs down).

NOTE: Space the retainer in the housing bore so that the four tangs rest on the ridge in the housing bore and not in the recesses.

(10) Install the solenoid coil retainer washer.

(11) Install the starter solenoid return spring into the bore of the movable core.

(12) Straighten the solenoid lead wires and install

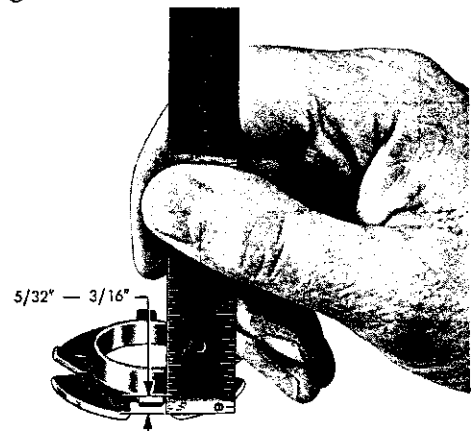

Fig. 38—Measuring the Height of the Solenoid Coil Retainer Tangs

the solenoid contact seal over the wires, inserting the double wires of the terminal stud into the large hole (Fig. 25) and the solenoid winding lead wire into the small hole.

(13) Insert the ends of the terminal stud wires into the groove of the terminal stud, crimp wires in place and solder with resin core solder.

NOTE: Inspect the condition of the starter solenoid switch contacting washer, if the top of washer is burned from arcing, disassemble the contact switch plunger assembly and reverse the washer.

(14) Install the solenoid contact plunger assembly into the solenoid and reform the double wires to allow for proper entry of the terminal stud into the brush holder with the double wires curved around the contactor.

CAUTION: The contactor must not touch the double wires when the solenoid is energized after the assembly is completed, (Fig. 25).

NOTE: Make sure the contact spring is positioned on the solenoid contact assembly.

(15) Assemble the battery terminal stud in the brush holder placing the sealing washer under the plain washer.

NOTE: Inspect the condition of the contacts in the brush holder plate. If the contacts are badly burned, replace the brush holder with brushes and contacts as an assembly.

(16) Enter the solenoid lead wire through the hole in the brush holder (Fig. 39) and solenoid stud, insulating washer, flat washer and nut.

NOTE: Use care when installing the solenoid contact seal over the tab on the brush plate to prevent tearing the seal.

(17) Solder the solenoid lead wire to the brush terminal post (Fig. 40). Wrap the wire securely

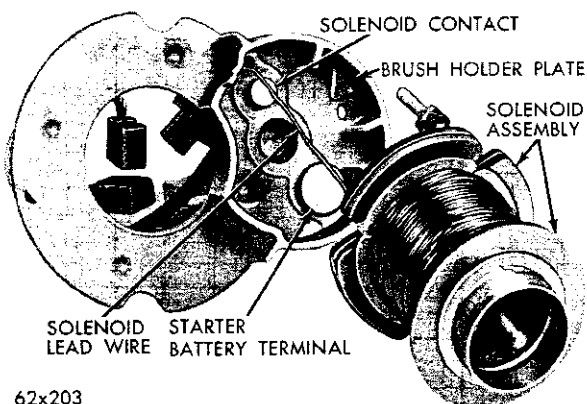

Fig. 39—Assembling Solenoid to Brush Holder Plate

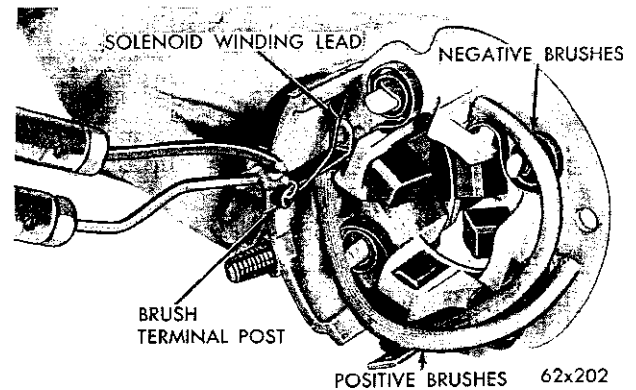

Fig. 40—Soldering Solenoid Winding Lead

around the terminal, and solder securely with a high temperature solder and resin flux.

(18) Carefully enter the solenoid coil and solenoid coil sleeve into the bore of the gear housing and position the brush plate assembly into the starter gear housing (Fig. 41). Align the tongue of the ground terminal with the notch in the brush holder.

(19) After the brush holder is bottomed in the housing, install the attaching screw (Fig. 22). Tighten the screw 10 to 15 inch pounds. Install the flat insulating washer and hold in place with friction tape.

(20) Position the brushes with Tool C-3855, as shown in Figure 42.

(21) Position the field frame to the exact position



Fig. 41—Installing Solenoid Coil, Sleeve and Brush Holder

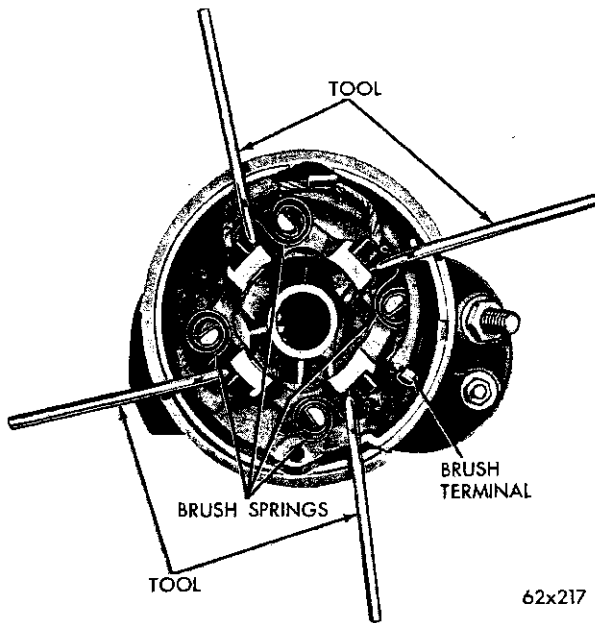

Fig. 42—Positioning Brushes with Tool Set C-3855

and resolder the field coil lead (Fig. 21).

(22) Install the brush terminal screw (Fig. 20).

(23) Install the armature thrust washer on the gear housing Fig. 19) and enter the armature into the field frame and gear housing (Fig. 43); carefully engaging the splines of the shaft with the reduction gear.

(24) Remove the brush positioning Tools C-3855 (Fig. 44).

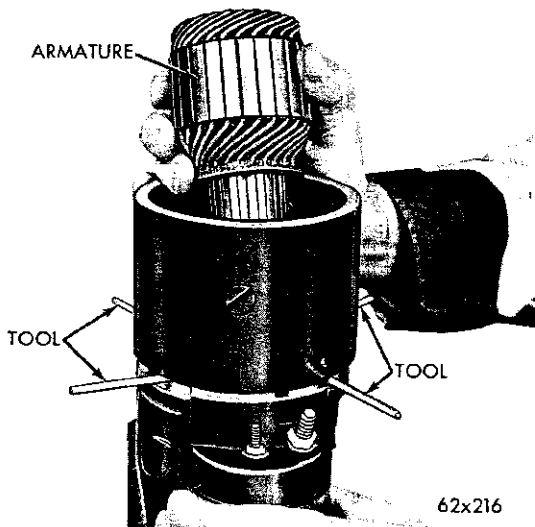

Fig. 43—Installing Starter Armature

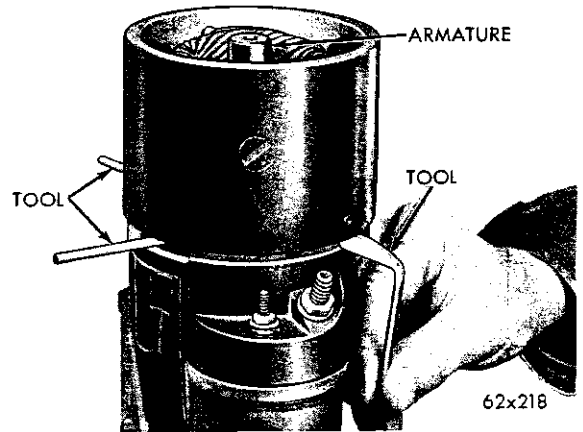

Fig. 44—Removing Brush Positioning Tools

(25) Install the thrust washer (fibre) and washer (steel) on the armature shaft.

(26) Position the starter end head assembly and install the starter frame screws and lockwashers. Tighten the screws securely.

(27) Install the starter gear housing dust cover. Make sure the dimples on the cover are securely engaged in the holes provided in the gear housing.

(28) Install the ground screw in the gear housing.

(29) Clean the area at the joint between the brush holder plate to field frame and gear housing mating joint. Apply a bead of brush plate sealer MoPar Part No. 2421847 around the four sides of the joint (Fig. 45).

CAUTION: Sealer must be flowed continuously to avoid gaps. After bead has been flowed on, use a brush or small paddle moistened in mineral spirits to press adhesive into joint. Be sure not to get the adhesive on the battery and/or solenoid terminals.

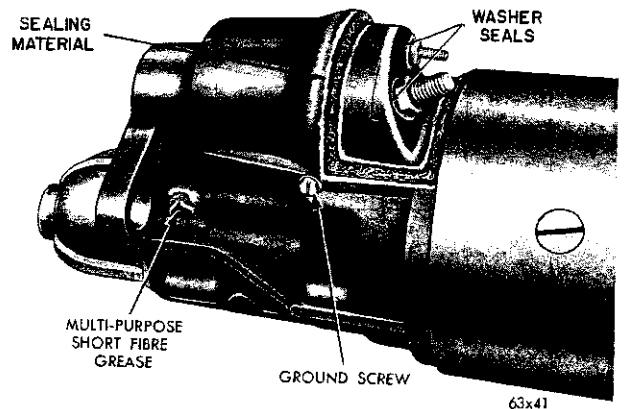

Fig. 45—Sealing the Brush Holder Plate

Installation

(1) Before installing the starting motor, make sure the starter and flywheel housing mounting surfaces are free of dirt and oil to insure a good electrical contact.

(2) Position the starter to flywheel housing removable seal.

(3) Install the starting motor, washer and bolt and washer and nut.

NOTE: When tightening the attaching bolt and nut be sure to hold the starting motor pulled away from the engine to insure proper alignment.

(4) Attach the wire at the solenoid switch terminal and cable to starter terminal.

(5) Connect the battery ground cable and test the operation of the starting motor for proper engine cranking.

PART 3

ALTERNATOR AND VOLTAGE REGULATOR

28. CONSTRUCTION AND OPERATION

The alternator (Fig. 46) is fundamentally an A.C. current generator, with six (6) built-in silicon rectifiers, that convert the A.C. current into D.C. current. D.C. current is available at the "output" "BAT" terminal. A voltage regulator (Fig. 47) is used in the field circuit to limit the output voltage.

The main components of the alternator are the rotor, the stator, the rectifiers, the two end shields and the drive pulley. (See Fig. 48).

29. VOLTAGE REGULATOR

The only function of the regulator is to limit the output voltage. The voltage regulator accomplishes this by controlling the flow of current in the rotor field coil, and in effect controls the strength of the rotor magnetic field.

30. TESTING THE ALTERNATOR SYSTEM (On Vehicle)

Field Circuit Resistance Test (Fig. 49)

(1) Disconnect the ignition wire at the coil side of

the ballast resistor and connect the positive lead of a test D.C. voltmeter to the battery positive post and connect the test voltmeter negative lead to the voltage regulator "FLD" (field) terminal; no other lights or accessories on.

(2) Turn the ignition switch on and turn the voltmeter selector switch to the low voltage scale and read the meter. The voltage should not exceed .55 volt. A reading in excess of .55 volt indicates high resistance in the field circuit between the battery and the voltage regulator field terminal.

(3) If high resistance is indicated, move the negative voltmeter lead to each connection along the circuit towards the battery. A sudden drop in voltage indicates a loose or corroded connection between that point and the last point tested. To test the terminals for tightness, attempt to move the terminal while observing the voltmeter. Any movement of the meter pointer indicates looseness.

NOTE: Excessive resistance in the regulator wiring circuit will cause fluctuation in the ammeter.

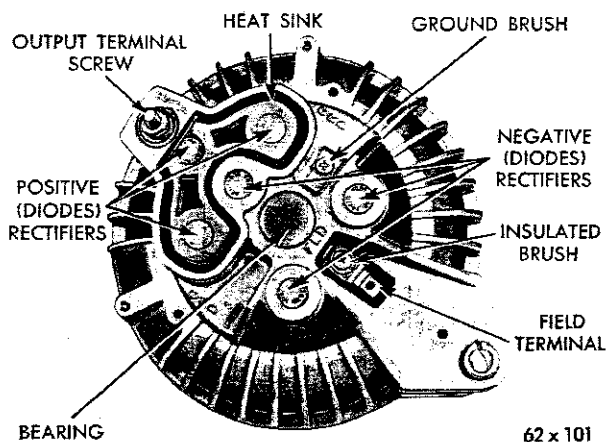

Fig. 46—Alternator Assembly

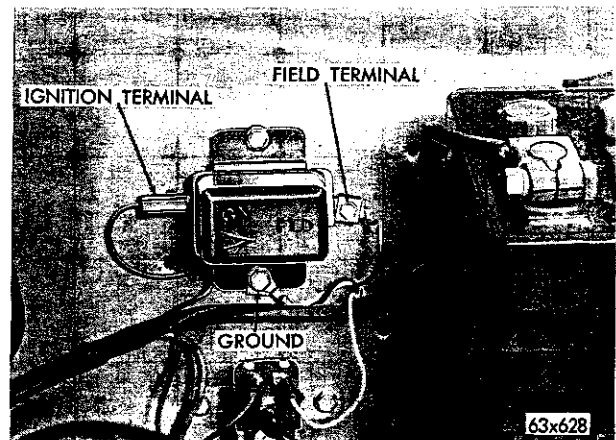
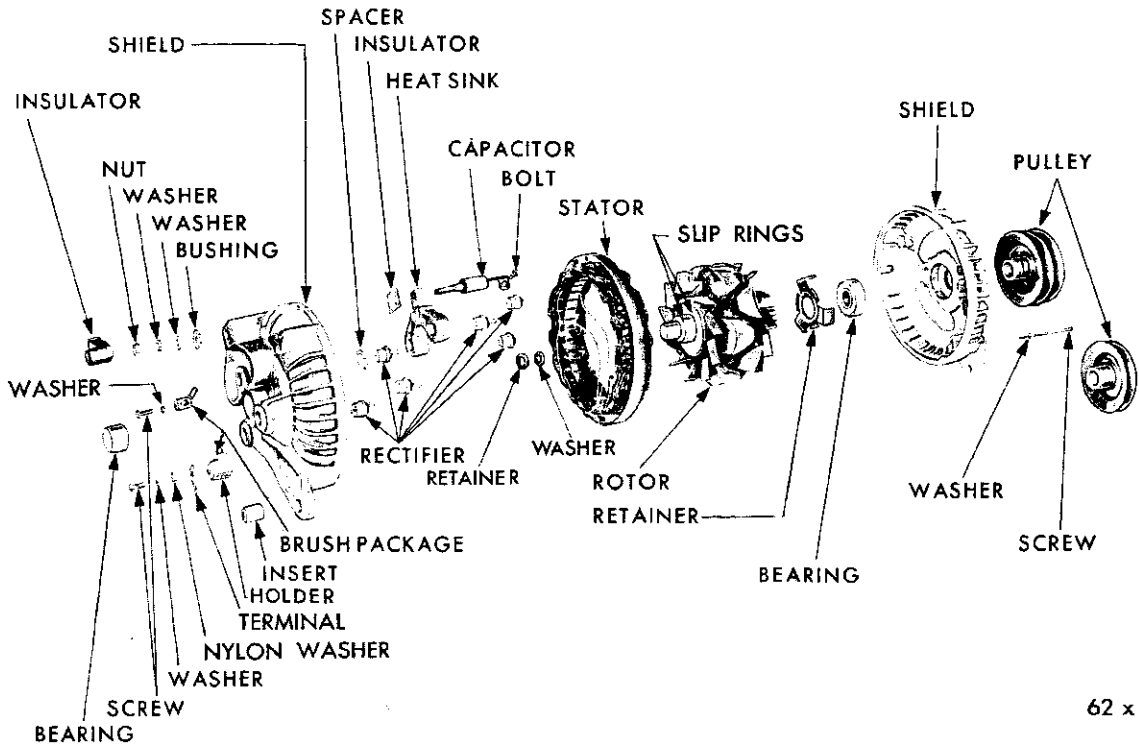

Fig. 47—Voltage Regulator Installed (Typical)



62 x 240A

Fig. 48—Alternator—Exploded View

(4) Turn the ignition switch off, disconnect test instrument and reconnect ignition primary wire at the coil side of the ballast resistor.

Charging Circuit Resistance Test

Test the condition of the battery and state of charge. With the battery in good condition and fully

charged, proceed with the tests as follows:

NOTE: Disconnect the battery ground cable at the battery negative post to avoid accidental shorting of the charging or field circuit when making test connections.

(1) Disconnect the lead at the alternator "BATT"

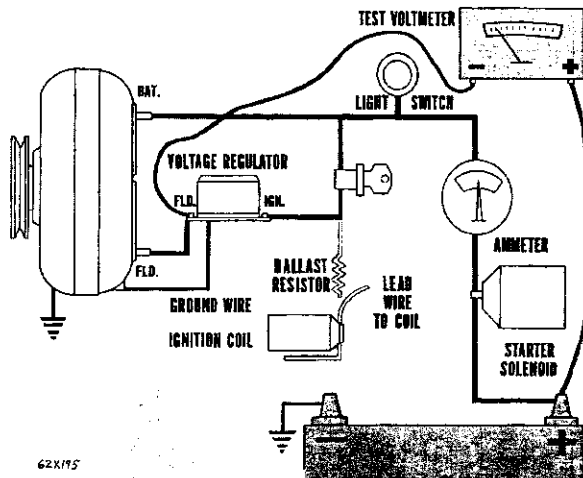

62X195

Fig. 49—Field Circuit Resistance Test

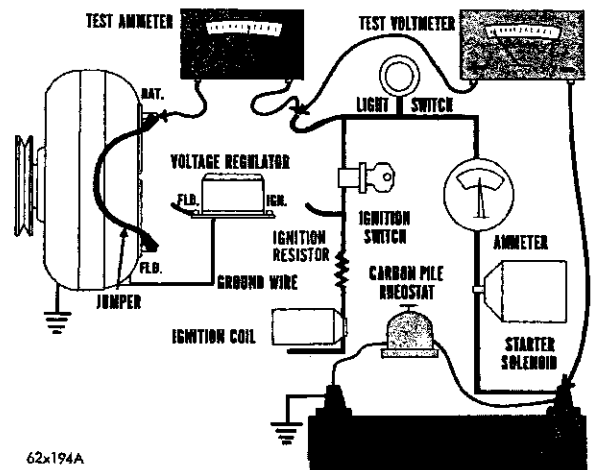

62x194A

Fig. 50—Charging Circuit Resistance Test

terminal. Connect a 0-50 ampere scale D.C. ammeter in series between the "BATT" terminal and "BATT" lead which was disconnected from the terminal (Fig. 50).

(2) Connect the positive lead of a test D.C. voltmeter to the "BATT" lead, and connect the negative voltmeter lead to the battery positive (+) terminal.

(3) Disconnect the field lead at the alternator "FLD" (field) terminal and the ignition lead at the regulator "ignition" terminal. Connect a special jumper between the alternator "FLD" (field) terminal and the alternator "BATT" (Battery) Terminal. This will ensure that there will be no interference from the voltage regulator.

(4) Reconnect the battery ground cable at the battery negative terminal.

(5) Connect a Battery-Starter Tester (equipped with a variable carbon pile) to the battery terminals.

(6) Start and operate the engine at a speed to obtain 10 amperes flowing in the circuit. Observe the voltmeter reading. The voltmeter reading should not exceed .3 volt. If a higher voltage drop is indicated, inspect, clean and tighten all the connections in the charging circuit. A voltage drop test may be performed at each connection to locate the connection with excessive resistance.

(7) Turn ignition switch off. Disconnect the battery ground cable at the battery negative terminal. Disconnect the test instrument. Connect the "BATT" lead to the alternator "BATT" terminal and tighten securely. Connect the ignition lead at the regulator "ignition" terminal connect battery ground cable at battery negative terminal.

Current Output Test (Fig. 51)

(1) Disconnect the battery ground cable.

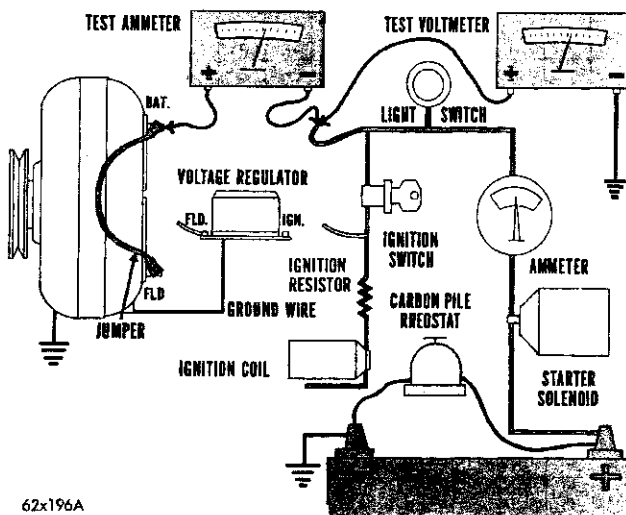

Fig. 51—Current Output Test

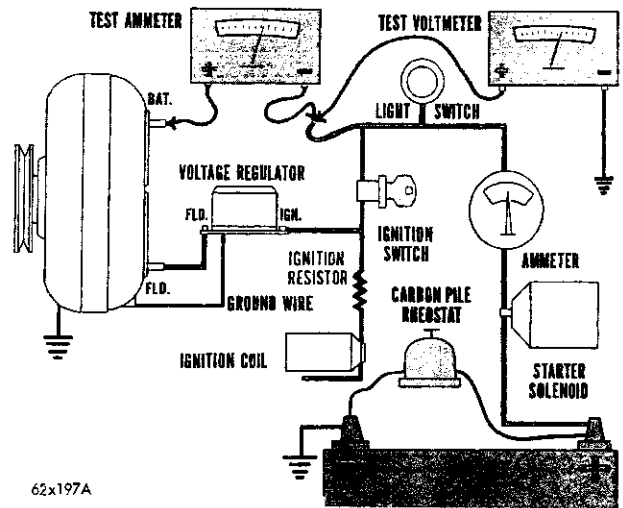

Fig. 52—Voltage Regulator Test

(2) Disconnect the "BATT" lead at the alternator output "BATT" terminal.

(3) Connect a 0-50 ampere scale D.C. ammeter in series between the alternator "BATT" terminal and the disconnected "BATT" lead.

(4) Connect the positive lead of a test voltmeter to the output "BATT" lead. Connect the negative lead of the test voltmeter to ground.

(5) Disconnect the field "FLD" lead at the alternator, and the ignition lead at the regulator ignition terminal.

(6) Connect a "jumper" lead from the alternator field "FLD" terminal to the alternator output "BATT" terminal. Be sure the ammeter lead is satisfactorily connected to the output "BATT" terminal.

(7) Connect an engine tachometer. Connect the battery ground cable.

(8) Connect a battery-starter tester (equipped with a variable carbon pile) to the battery terminals.

(9) Start and operate the engine at 1250 rpm.

(10) Adjust the "carbon pile" to obtain a reading of 15 volts on the test voltmeter.

(11) Observe the reading on the test ammeter.

The current output should be within the limits shown in "Specifications".

If the output is slightly less (5 to 7 amperes) than that specified above, it may be an indication of possible "open" rectifier or other alternator internal problem. If the output is considerably lower than that specified above, it may be an indication of a possible "shorted" rectifier or other alternator internal problem. In either case the alternator should be removed and tested on the bench before disassembly.

NOTE: Turn off the carbon pile immediately after observing the reading on the test ammeter.

If the alternator current output tested satisfactorily; turn off the ignition switch and remove the jumper lead from the alternator "field" terminal and "output" terminal.

Voltage Regulator Test (On the Vehicle)—Engine at Normal Operation Temperature (Fig. 52)

Upper Contact Test

(1) Connect the field lead at the alternator field "FLD" terminal and the regulator ignition terminal lead to the ignition terminal. The test ammeter, voltmeter leads and carbon pile remain connected as outlined in the "Current Output Test".

NOTE: If the field circuit is grounded on the field terminal side of the regulator circuit when removing or installing the lead, while the ignition is ON, the fuse wire in the regulator circuit will be blown and the regulator may be damaged.

(2) Start and operate the engine at 1250 rpm. Adjust carbon pile to obtain a 15 ampere output as registered on the test ammeter.

NOTE: No current reading on test ammeter would indicate either a low set regulator or a blown fuse wire inside the voltage regulator between the upper stationary contact and the "IGN" terminal. Correct the acuse and replace the fusible wire.

(3) Operate the engine at 1250 rpm and a 15 ampere load for 15 minutes to make sure the entire regulator system is stabilized.

(4) Measure the temperature at the regulator by holding a reliable thermometer $\frac{1}{4}$ inch from the regulator cover.

(5) Read the test voltmeter. With a fully charged battery and 15 amperes flowing in the circuit, the voltmeter reading should be within the specifications.

If the regulator operates within specifications, proceed to the lower contact voltage test. If the upper contact voltage setting is not within specifications, remove the regulator cover and adjust the voltage setting as outlined in "Regulator Adjustments" test number (1).

Lower Contacts Voltage Test

(1) Increase engine speed to 2200 rpm. Vary the carbon pile to decrease the current load to 7 amperes output as registered on the test ammeter. The voltage should increase and amperage should decrease.

NOTE: There will be a slightly higher voltage at higher engine speeds above 2200 rpm, however, this increased voltage must not exceed the voltage specified by more than .7 volt at any temperature range. If the voltage reading is less than .2 volt from readings in Step (5) under "Upper Contact Test", test the battery specific gravity to be sure battery is fully charged.

(2) If the regulator setting is outside the limits shown, the regulator must be removed to remove the cover. To adjust the voltage setting, bend the regulator lower spring hanger down to increase voltage setting, or up to decrease voltage setting. Use an insulated tool to bend the spring hanger. (See Fig. 53). The regulator must be installed, correctly connected, and retested after each adjustment of the lower spring hanger.

NOTE: If repeated readjustment is required, it is permissible to use a jumper wire to ground the regulator base to the fender splash shield for testing, in lieu of reinstalling the regulator each time. However, it is important that the regulator cover be reinstalled, the regulator connections correctly connected, and the regulator satisfactorily insulated by the fender cover to prevent grounding the regulator terminals or resistances. When testing, the regulator must be at the same attitude (or angle) as when installed on the vehicle.

(3) If the alternator and regulator tested satisfactorily, turn the ignition switch "OFF". Disconnect the battery ground cable. Disconnect the test instruments. Correctly connect the leads at the alternator and regulator. Connect the battery ground cable.

CAUTION: Be sure the negative post of the battery is always connected to ground. Incorrect battery polarity may result in wiring harness damage and may damage the alternator rectifiers. Do not ground the alternator field circuit, as this may damage the regulator.

31. REGULATOR

Mechanical Adjustments

If the regulator cannot be satisfactorily adjusted for voltage control, or if the regulator performance is

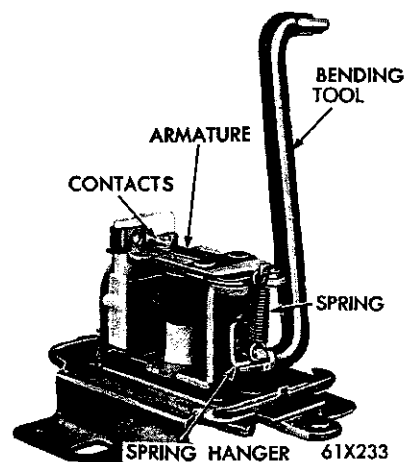
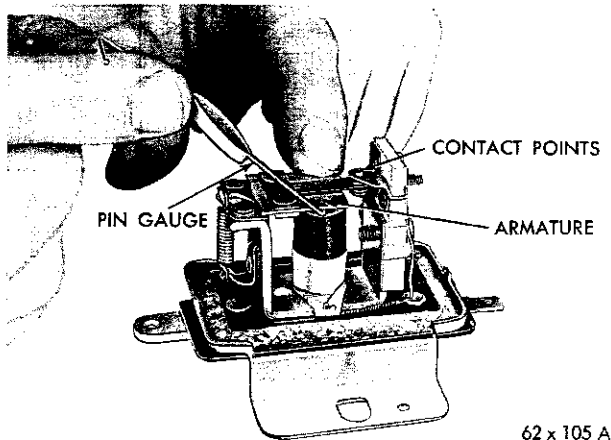

Fig. 53—Adjusting Spring Tension



62 x 105 A

Fig. 54—Testing the Air Gap

erratic or malfunctions, it may be necessary to adjust the regulator air gap and contact point gap.

(1) Remove the regulator from the vehicle. Remove the regulator cover.

(2) Insert a .048 inch wire gauge between the regulator armature and the core, next to the stop pin on the spring hanger side (Fig. 54).

(3) Press down on the armature (not the contact spring) until it contacts the wire gauge. The upper contacts should just "open".

NOTE: A 12 volt battery and test light connected in series to the "IGN" and "FLD" terminals may be used to accurately determine the contact opening. When the contacts open, the test light will go "dim".

(4) Insert a .052 inch wire gauge between the armature and the core, next to the stop pin on the spring hanger side.

(5) Press down the armature until it contacts the wire gauge. The contacts should remain "closed", and the test light should remain "bright".

(6) If adjustment is required, adjust the air gap by loosening the screw and moving the stationary contact bracket; make sure the air gap is measured with attaching screw fully tightened. Remeasure the air gap, as described in steps (2), (3), (4) and (5.)

(7) Remove the wire gauge from under the armature. Measure the lower contact gap with a feeler gauge. The lower contact gap should be .014 inch (plus or minus .002"). Adjust the lower contact gap by bending the lower stationary contact bracket.

(8) Install the regulator cover. Install the regulator. The electrical adjustment must be performed on the vehicle after installation of the regulator.

32. ALTERNATOR

Removal

If the alternator performance does not meet current output specification limits, it must be removed and disassembled for further test and servicing.

(1) Disconnect the battery ground cable.

(2) Disconnect the alternator output "BAT" and field "FLD" leads and disconnect the ground wire.

(3) Remove the alternator from the vehicle.

33. BENCH TESTS

Field Coil Draw

If the alternator field coil draw has not been tested on the vehicle it may be tested on the test bench as follows:

(1) Connect the positive lead of a test ammeter to the positive terminal of a fully charged battery. Connect a jumper wire to the negative terminal of the battery, and ground it to the alternator end shield. Connect the test ammeter negative lead to the field terminal of the alternator.

(2) Slowly rotate the alternator rotor by hand. Observe the ammeter reading. The field coil draw should be 2.3 amperes to 2.7 amperes at 12 volts.

NOTE: A low rotor coil draw is an indication of high resistance in the field coil circuit, (brushes, slip rings, or rotor coil). A higher rotor coil draw indicates a possible shorted coil or a grounded rotor.

Testing Alternator Internal Field Circuit for a Ground

(1) To test the internal field circuit for a ground, remove the ground brush. Touch one test prod from a 110 volt test lamp to the alternator insulated brush terminal and the remaining test prod to the end shield. If the rotor assembly or insulated brush is

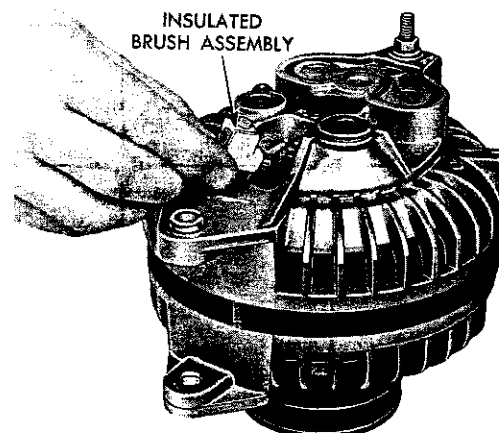

62 x 106

Fig. 55—Removing or Installing Insulated Brush

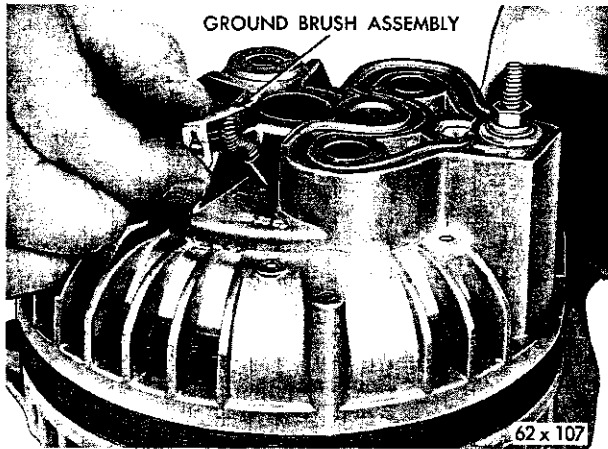

Fig. 56—Removing or Installing Ground Brush

not grounded, the lamp will not light.

(2) If the lamp lights, remove the insulated brush assembly (noting how the parts are assembled) and separate the end shields by removing the three thru bolts.

(3) Again test by placing one of the test prods to a slip ring and the remaining test prod to the end shield. If the lamp lights, the rotor assembly is grounded and requires replacement. If the lamp does not light after removing the insulated brush and separating the end shields, the cause of the ground at the first ground test was that the insulated brush is grounded.

(4) Examine the plastic insulator and the screw. The screw is a special size and must not be substituted by another size.

(5) Install the insulated brush holder, terminal, insulated washer, shake proof washer and screw. If the parts were not assembled in this order or if the

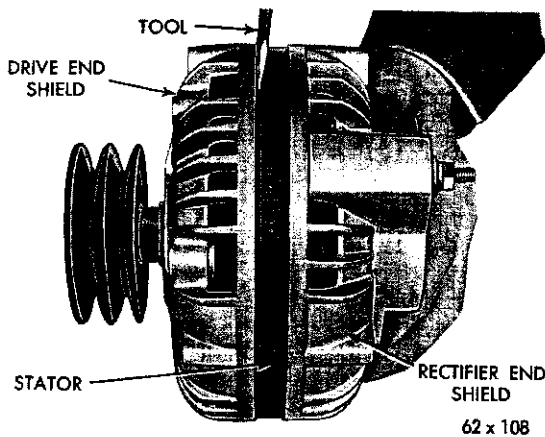

Fig. 57—Separating Drive End Shield from Stator

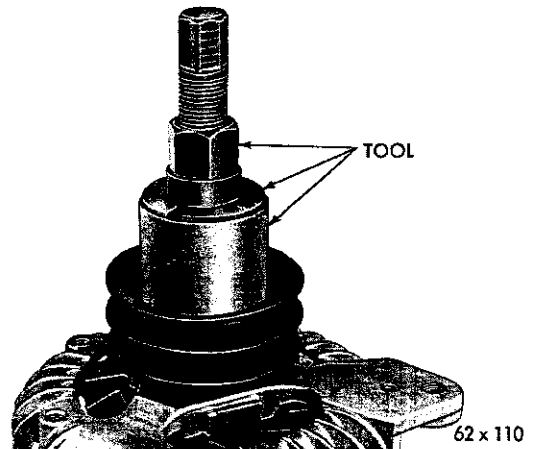

Fig. 58—Removing Pulley

wrong screw was used this could be the cause of the ground condition.

Disassembly

To prevent possible damage to the brush assemblies, they should be removed before proceeding with the disassembly of the alternator. The insulated brush is mounted in a plastic holder that positions the brush vertically against one of the slip rings.

(1) Remove the retaining screw lockwasher, insulated washer, and field terminal, and carefully lift the plastic holder containing the spring and brush assembly from the end housing (Fig. 55).

(2) The ground brush is positioned horizontally against the remaining slip ring and is retained in a holder that is integral with the end shield. Remove the retaining screw and lift the clip, spring and brush assembly from the end shield (Fig. 56).

CAUTION: The stator is laminated, do not burr stator or the end shield.

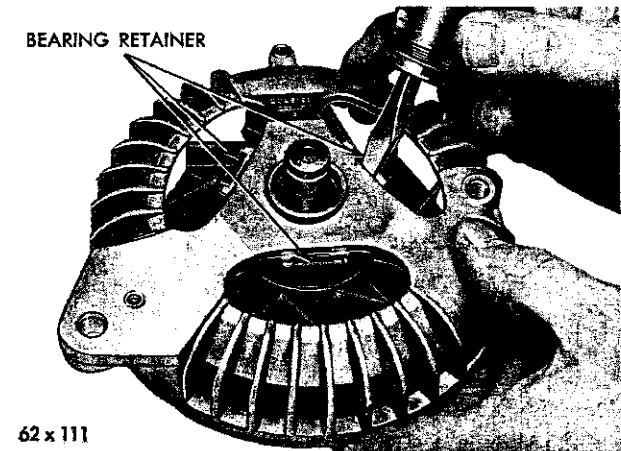

Fig. 59—Disengaging the Bearing Retainer from the End Shield

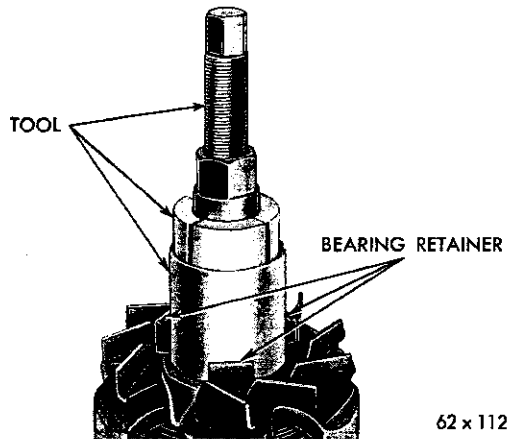

Fig. 60—Removing the Bearing from the Rotor Shaft

(3) Remove the through bolts and pry between the stator and drive end shield with the blade of a screwdriver (Fig. 57). Carefully separate the drive end shield, pulley and rotor assembly away from the stator and the rectifier shield assembly.

(4) The pulley is an interference fit on the rotor shaft. Remove the pulley with puller Tool C-3615 and special adaptor SP-3002 (Fig. 58).

(5) Pry the drive end bearing spring retainer from the end shield with a screwdriver (Fig. 59).

(6) Support the end shield and tap the rotor shaft with a plastic hammer to separate the rotor from the end shield.

NOTE: The new bearing is lubricated with a predetermined amount of special lubrication and does not require additional lubrication.

(7) The drive end ball bearing is an interference fit with the rotor shaft. Remove the bearing with puller Tool C-3615 and adapter as follows:

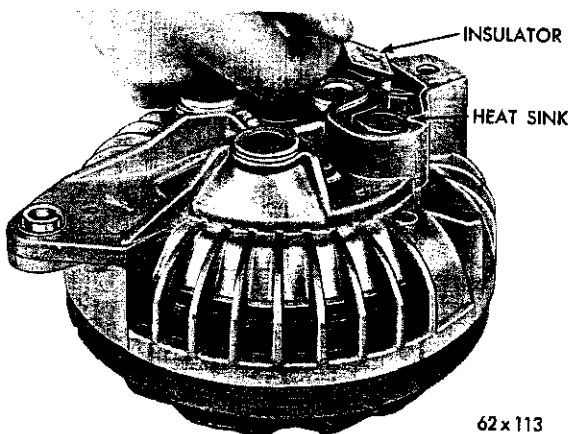

Fig. 61—Removing the Heat Sink Insulator

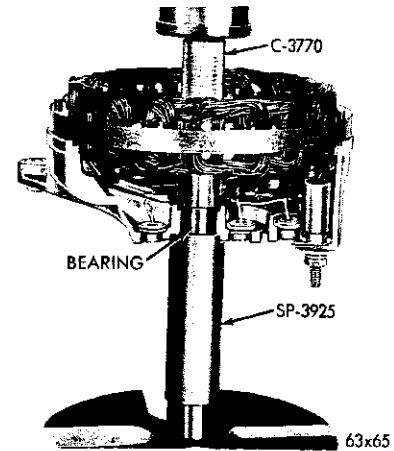

Fig. 62—Removing the Rectifier End Shield Bearing

(a) Position the center screw of Tool C-3615 on the rotor shaft.

(b) Place the thin lower end of the adapters SP-3375 under the bearing equally spaced and the upper end of the adapters around the center screw.

(c) Hold the adapters and center screw in position with the tool sleeve.

CAUTION: The tool sleeve must bottom on the bearing, otherwise, the adapters may be damaged.

(d) Turning the center screw while holding the outer body of tool (Fig. 60) will withdraw the bearing from the rotor shaft.

(8) Remove the D.C. output terminal nuts and washers and remove the terminal screw and inside capacitor (on units so equipped).

NOTE: The heat sink is also held in place by the terminal screw.

(9) Remove the insulator (Fig. 61).

(10) The needle roller bearing in the rectifier end shield is a press fit. If it is necessary to remove the

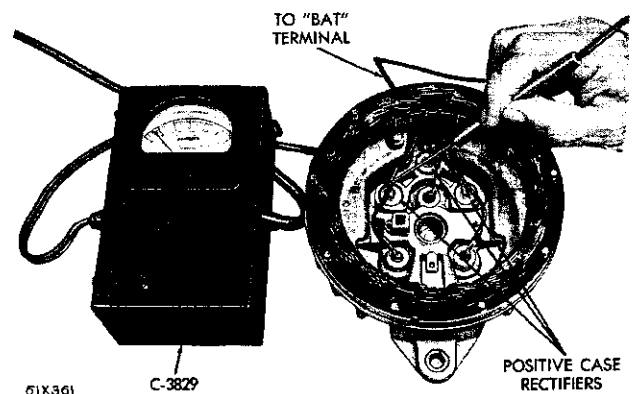

Fig. 63—Testing Positive Rectifiers (Typical)

rectifier end frame needle bearing, protect the end shield by supporting the shield with Tool SP-3925 when pressing the bearing out with Tool C-3770 (Fig. 62).

NOTE: The new bearing is prelubricated and no additional lubricant should be added, as an excessive amount of lubricant will contaminate the slip rings and cause premature brush and rotor failures.

34. TESTING THE RECTIFIERS WITH TOOL C-3829

The new Rectifier Tester Tool C-3829 provides a quick, simple and accurate method to test the alternator rectifiers without the necessity of disconnecting the soldered rectifier leads. With the alternator rectifier and end shield separated from the drive end housing proceed with the rectifier tests as follows:

Positive Case Rectifier Test (Fig. 63)

(a) Place the alternator on an insulated surface. Connect the test lead clip to the alternator ("BAT") output terminal.

(b) Plug in the Tool C-3829 power source lead into a 110 volt A.C. power supply. Touch the exposed metal connections, of each of the positive case rectifiers, with the test prod.

CAUTION: Do not break the sealing around the rectifier lead wire. The sealing material is for protection against corrosion. Always touch the test prod to the exposed metal connection nearest the rectifier.

The reading for satisfactory rectifiers will be 1 3/4 amperes or more. The reading should be approximately the same for the three rectifiers.

When two rectifiers are good and one is shorted, the reading taken at the good rectifiers will be low, and the reading at the shorted rectifier will be zero. Disconnect the lead to the rectifier reading zero and retest. The reading of the good rectifiers will now be within the satisfactory range.

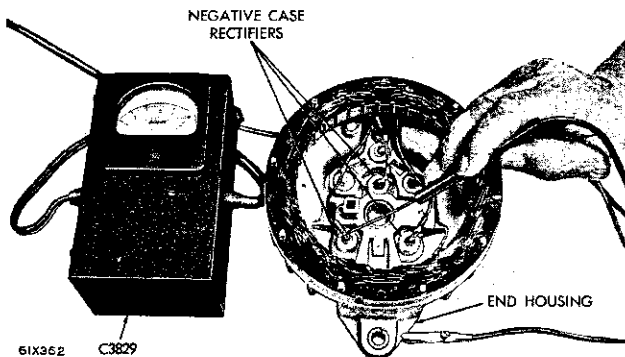

Fig. 64—Testing Negative (Typical)

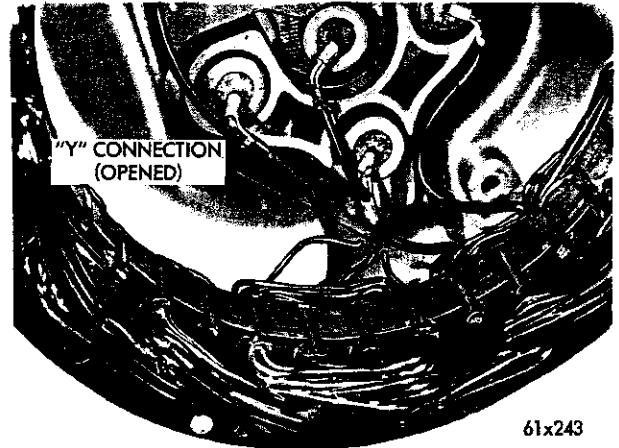

Fig. 65—Separating the Three Stator Leads (Typical)

When one rectifier is open it will read approximately one ampere, and the two good rectifiers will read within the satisfactory range.

Negative Case Rectifier Test (Fig. 64)

(a) Connect the test lead clip to the rectifier end housing.

(b) Touch the exposed connection of each of the negative case rectifiers with the test prod.

The test specifications are the same, and the test results will be approximately the same as for the positive case rectifiers, except the meter will read on the opposite side of the scale.

35. TESTING THE RECTIFIERS AND STATOR (WITHOUT TOOL C-3829)

(a) Separate the three (3) stator leads at the "Y" connection (Fig. 65).

NOTE: Cut the stator connections as close to the connector as possible because they will have to be

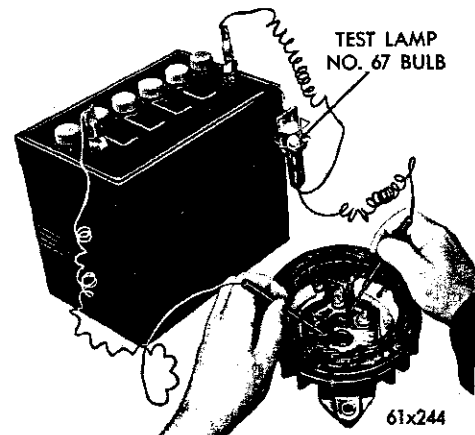

Fig. 66—Testing Rectifiers with Test Lamp (Typical)

soldered together again. If they are cut too short it may be difficult to get them together again for soldering.

(b) Test the rectifiers with a 12 volt battery and a test lamp equipped with a number 67 bulb (4 candle power) by connecting one side of test lamp to the positive battery post and the other side of the test lamp to a test probe. Connect another test probe to the negative battery post.

(c) Contact the outer case of the rectifier with one probe and the other probe to the wire in the center of the rectifier (See Fig. 66).

(d) Reverse the probes, moving the probe from the rectifier outer case to the rectifier wire, and the probe from the rectifier wire to the rectifier outer case.

If the test lamp "lights" in one direction but does "not light" in the other direction, the rectifier is satisfactory. If lamp lights in "both directions", the rectifier is "shorted". If the test lamp does "not light" in either direction, the rectifier is "open".

NOTE: Possible causes of an open or a blown rectifier is a faulty capacitor or a battery that has been installed in reverse polarity. If the battery is installed properly and the rectifiers are open, test the capacitor capacity .50 microfarad plus or minus 20%.

(e) Unsolder the rectifier leads from the stator leads.

(f) Test the stator for grounding using a 110 volt test lamp (Fig. 67). Use wood slats to insulate the stator from the rectifier shield. Contact one prod of the test lamp to the stator pole frame, and contact the other prod to each of the three stator leads. The test lamp should "not light". If the test lamp lights, the stator windings are "grounded".

(g) Test the stator winding for continuity, by contacting one prod of the test lamp to all three stator

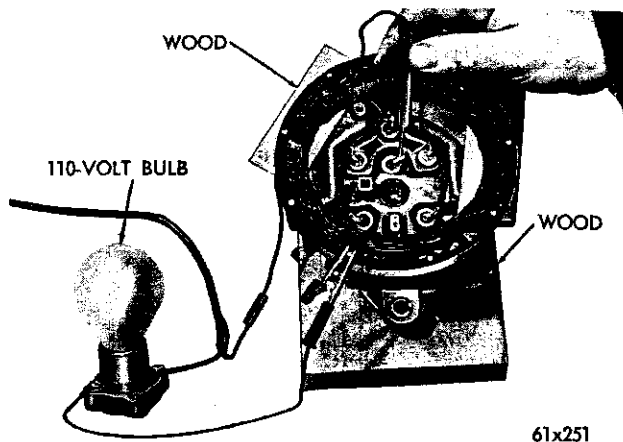

Fig. 67—Testing Stator for Grounds (Typical)

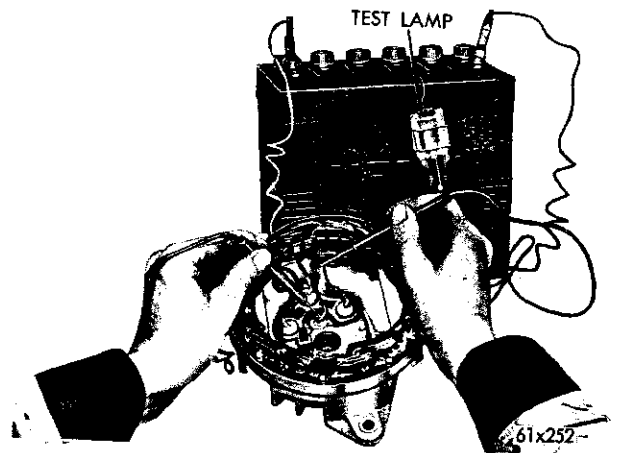

Fig. 68—Testing Stator Windings for Continuity (Typical)

leads at the "Y" connection. Contact each of the three stator leads (disconnected from the rectifiers). The test lamp should "light" when the prod contacts each of the three leads. If the test lamp does not light the stator winding is "open". (See Fig. 68).

(h) Install a new stator if the one tested is "grounded" or "open". If the rectifiers must be replaced unsolder the rectifier wire at the soldered joint.

NOTE: Three rectifiers are pressed into the heat sink and three in the end shield. When removing the rectifiers, it is necessary to support the end shield and/or heat sink to prevent damage to these castings.

(i) Place the rectifier support adapter in the platform of Tool C-3910 and the remover adapter into the end of the tool pressure screw.

(j) Place the clamp tool in a vise and support the end shield on the support adapter under the rectifier to be removed (Fig. 69).

NOTE: The support tool adapter is cut-away and slot-

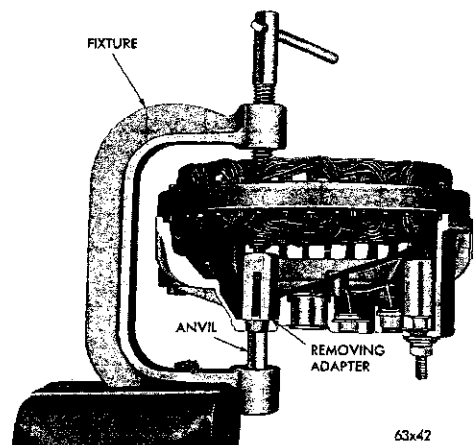
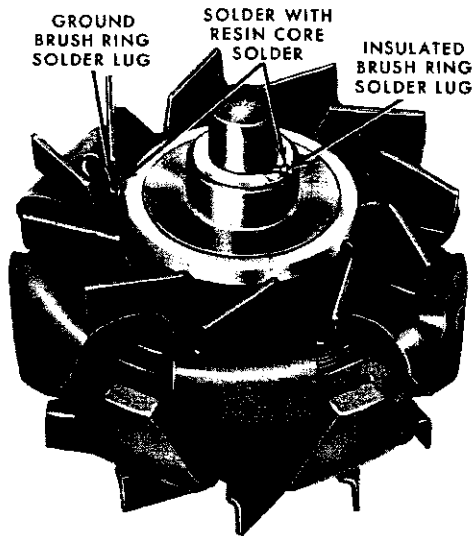

Fig. 69—Removing Rectifier



62X 529

Fig. 70—Solder Points—Slip Ring Installed

ted to fit over the wires and around the bosses in the end shield. Make sure that the bore of the tool completely surrounds the rectifier.

(k) Carefully apply pressure with the tool pressure screw until the support tool rectifier end shield and remover pin are in alignment then press the rectifier out of the end shield.

36. REPLACING SLIP RINGS

Slip rings that are damaged can be replaced as follows:

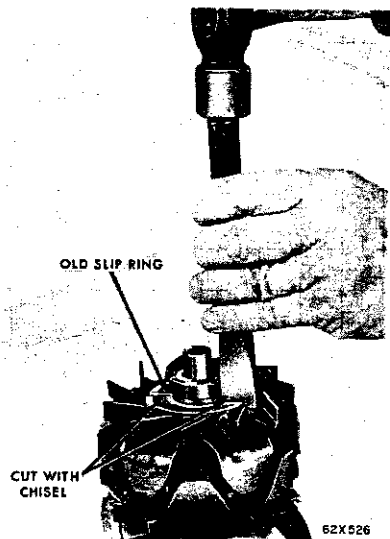

62X526

Fig. 71—Cutting the Old Slip Rings

(1) Cut through the rotor grease retainer with a chisel and remove the retainer and insulator.

(2) Unsolder the field coil leads at the solder lugs (Fig. 70).

(3) Cut through the copper of both slip rings at opposite points (180° apart) with a chisel (Fig. 71).

(4) Break the insulator and remove the old ring.

(5) Clean away dirt and particles of the old slip ring from the rotor.

(6) Scrape the ends of the field coil lead wires clean for good electrical contact.

(7) Scrape one end (about $\frac{3}{16}$ inch) of a piece of bare wire (approx. 18 gauge) three inches long (to be used as a guide wire).

(8) Tin the scraped area of the guide wire with resin core solder. Lap the tinned end of the wire over the field coil lead to the insulated ring and solder the two together.

(9) Position the new slip ring carefully over the guide wire and the rotor shaft so the wire will lay in the slip ring groove (Fig. 72). The groove in the slip ring must be in line with the insulated brush field lead to provide room for the lead without damaging it.

(10) Place installing Tool C-3900 over the rotor shaft with the guide wire protruding from the slot in the tool.

(11) Position the rotor, slip ring and tool assembly in an arbor press (Fig. 73). Pull upon the guide wire being careful to guide the insulated field lead into the slip ring groove. While guiding the insulated

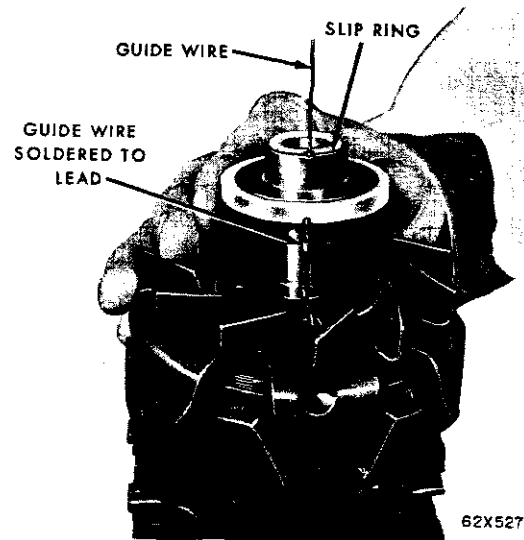

62X527

Fig. 72—Aligning Slip Ring with Field Wire and Guide Wire

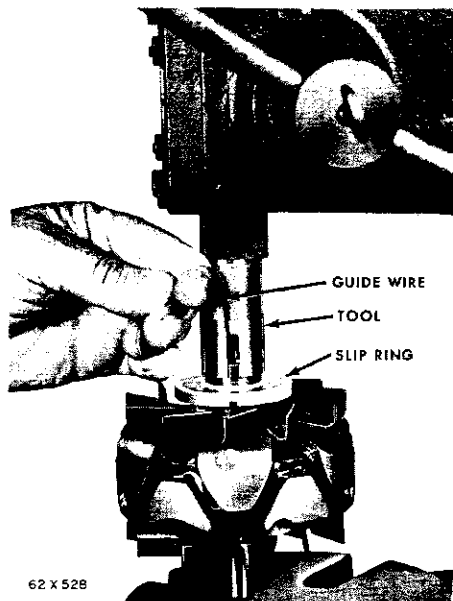

Fig. 73—Installing Slip Ring

field lead through the groove, press the slip ring on the shaft. When the slip ring is bottomed on the rotor fan the end of the field lead should be visible at the solder lug (Fig. 70).

(12) Unsolder the guide wire from the insulated brush slip ring lead. Press the field lead into the solder lug and solder to lug with resin core solder.

CAUTION: Be sure the solder bead does not protrude beyond the surface of the plastic material. Do not use acid core solder. A short circuit may result and corrosion will definitely occur.

(13) Coil the ground brush ring field lead around the solder lug (Fig. 70) and solder with resin core solder.

(14) Test the slip rings for ground with a 110 volt test lamp by touching one test prod to the rotor pole shoe and the remaining prod to the slip rings. The test lamp should not light. If the lamp lights, the slip rings are shorted to the ground, possibly due to a grounding insulated field lead when installing the slip ring.

If the rotor is not grounded, lightly clean the slip ring surfaces with -00- sand paper and assemble the alternator.

(15) Position the new grease retainer insulator and grease retainer on the rotor shaft and press the retainer on the shaft with installer Tool C-3921 (Fig. 74.) The retainer is properly positioned when the inner bore of the installed tool bottoms on the rotor shaft.

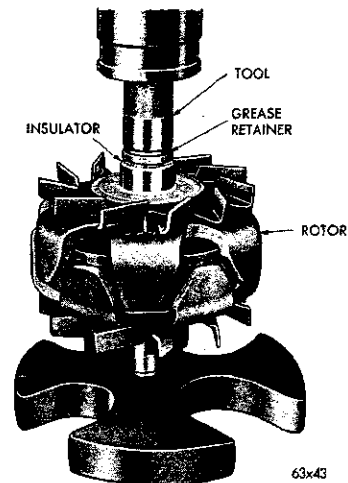

Fig. 74—Installing Bearing Grease Retainer

Assembling the Alternator

(1) Confirm the rectifier identification to make sure the correct rectifier is being installed. Refer to the Parts List of rectifier identification.

(2) Support the heat sink or rectifier end shield on the installer adapter SP-3820 of Tool C-3928. Carefully apply pressure with the tool pressure screw until the installer tool, rectifier, rectifier and shield or heat sink are in alignment and after determining that the rectifier is started squarely in the casting, slowly apply pressure with the tool pressure screw until you feel the collar of the rectifier bottom against the casting (Fig. 75).

NOTE: Make sure that the installer support adapter fits squarely around the rectifier inner boss and that pressure is applied on the outer rim of the rectifier.

CAUTION: DO NOT USE a hammer to start the rectifier into its bore in the end shield. DO NOT HAMMER OR SHOCK the rectifier in any manner as this

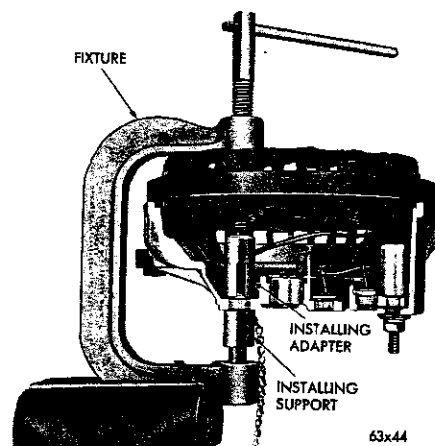

Fig. 75—Installing a Rectifier

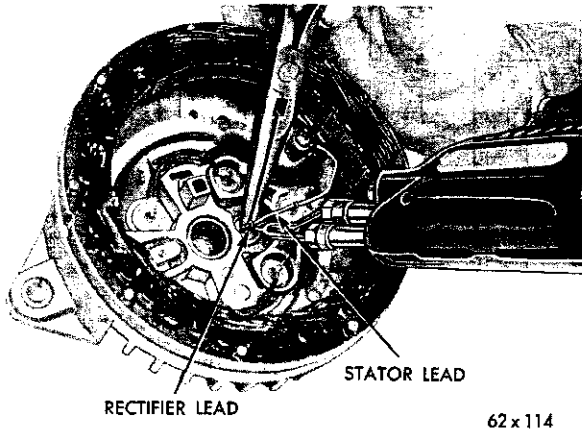

Fig. 76—Soldering the Rectifier and Stator Leads

will fracture the thin silicon wafer in the rectifier causing complete rectifier failure.

(3) If the stator leads were disconnected at disassembly; clean the leads and mate the stator lead with the rectifier wire loop and bend the loop snugly around the stator lead to provide a good electrical and mechanical connection. Solder the wires with resin core solder. Hold the rectifier lead wire with pliers just below the joint while soldering (Fig. 76.) The pliers will absorb the heat from soldering and protect the rectifier.

(4) After soldering the stator leads must be pushed down into the slots that are cast into the end shield and cemented with MoPar Cement, Part Number 2299314 to protect the leads against possible interference with the rotor fans. Test each replacement rectifier to make certain the rectifier was not damaged by the soldering or pressing operations.

(5) Support the end shield on Tool C-3925 so that

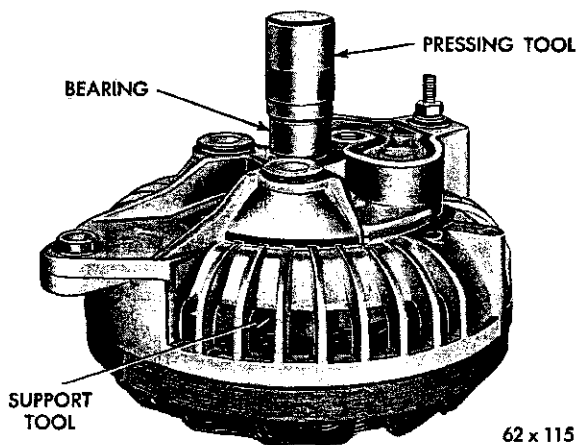

Fig. 77—Installing the Rectifier End Shield Bearing

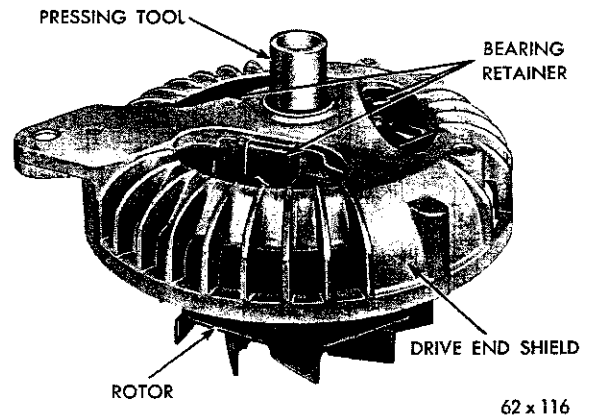

Fig. 78—Installing the Drive End Shield and Bearing

the notch in support tool will clear the raised section of the heat sink and press the bearing into position with Tool SP-3381 (Fig. 77).

NOTE: New bearings are pre-lubricated and additional lubrication is not required.

(6) Insert the drive end bearing in the drive end shield and install the bearing retainer plate to hold the bearing in place.

(7) Position the bearing and drive end shield on the rotor shaft and, while supporting the base of the rotor shaft, press the bearing and shield into position on the rotor shaft with arbor press and Tool C-3769 (Fig. 78).

CAUTION: Make sure that the bearing is installed squarely at installation; otherwise, damage to the bearing will result. Press the bearing on the rotor shaft until the bearing contacts the shoulder on the rotor shaft.

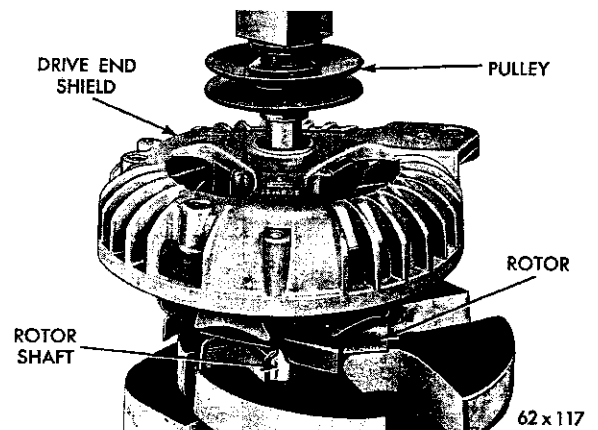

Fig. 79—Installing Alternator Pulley

(8) Install the pulley on the rotor shaft. The shaft of the rotor must be supported in a manner so that all pressing force is on the pulley hub and motor shaft (Fig. 79).

NOTE: Do not exceed 6800 pounds pressure. Press the pulley on the rotor shaft until the pulley contacts the inner race of the drive end bearing.

(9) The alternators have the capacitor mounted internally. Make sure the heat sink insulator is in place (Fig. 61).

(10) Install the capacitor stud through the heat sink and end shield.

(11) Install the insulating washers, lockwashers and lock nuts.

(12) Make sure the heat sink and insulator are in position and tighten the lock nut.

(13) Position the stator on the rectifier end shield.

(14) Position the rotor end shield assembly on the stator and rectifier end shield. Align the through bolt holes in the stator, rectifier end shield and drive end shield.

(15) Compress the stator and both end shields by hand and install the through bolts, washers and nuts.

(16) Install the insulated brush in the rectifier end. Place the bronze terminal on the plastic holder with the tab of the terminal in the recess in the plastic holder.

(17) Place the nylon washer on the bronze terminal and install the lockwasher and attaching screws.

(18) Install the ground brush and attaching screw.

(19) Rotate the pulley slowly by hand to be sure that the rotor fans do not hit the rectifiers, capacitor lead, and stator connections.

(20) Install the alternator and adjust the drive belt.

(21) Connect the output "BAT" and the field "FLD" leads and connect the ground wire.

(22) Connect the battery ground cable.

(23) Start and operate the engine, and observe the alternator operation.

(24) Test the current output and regulator voltage setting, if necessary.

PART 4

IGNITION SYSTEM

The ignition system consists of two separate circuits. The battery, ammeter, ignition switch, ballast resistor, primary winding of the ignition coil, distributor contacts and condenser, vehicle frame, and the primary wiring make up the low voltage primary circuit. The secondary high voltage circuit includes the coil secondary winding, the distributor cap and rotor, the spark plug cables, the spark plugs and the vehicle frame.

37. SECONDARY CIRCUIT INSPECTION

The coil to distributor cap wire and the spark plug wires should make good, clean contact in the ignition coil, the distributor cap towers and on the spark plugs. Wires that are loose or are not inserted all the way into the towers or on the plugs will corrode and increase the resistance as well as cause carbon tracking of the coil or cap towers. Make sure the spark plug nipples are in good condition and that they are tight on the spark plug terminals and around the plug insulators. **Always use Neoprene insulating nipples.**

The ignition coil tower, if oily or dirty, should be wiped clean and inspected for cracks, carbon tracking or oil leaks. Replace the coil if faulty.

Inspect the distributor cap for oil film, dirt or metal particles on the inside surface. Any contami-

nation, however slight, can become conducting and cause hard starting in wet weather. Thoroughly wash the cap in a **weak** solution of liquid soap or detergent in warm water. Do not use a concentrated solution or soak the cap in the solution. Scrub the inner surfaces with a stiff bristle nylon brush to clean between the ribs and the crevices. Rinse well in hot water, shake out excess water and dry thoroughly. Do not use compressed air to dry or blow out the water. Carefully inspect for cracks or carbon tracking on the inner or outer surfaces. Replace the cap if faulty.

The secondary cables, cap and rotor should be tested, using Tool C-3296. This tester provides high voltage which is sufficient for testing secondary insulation. Test the resistance of the spark plug cables.

Replace the cable if resistance is more than 30,000 ohms. Replace the cable if the terminal has pulled off.

NOTE: Pulling the wires to disconnect them from the plugs can stretch them and increase secondary resistance. To remove the wire, grasp the boot at the end of the wire and rotate the boot slightly to break the adhesion between it and the spark plug insulator.

The rotor and distributor cap electrodes should be inspected for burning. Replace the rotor if the elec-

trode is burned on the top or if the electrode is worn too short.

38. DISTRIBUTION RESISTANCE TEST

This test indicates the resistance of the ignition primary circuit from the distributor side of the coil, through the points and the distributor ground. Excessive resistance in this portion of the ignition system will prevent the coil from producing sufficient output for good over-all ignition. To perform test, proceed as follows:

(1) Turn the Selector Switch of a tach-dwell unit to the CALIBRATE position and adjust the Dwell Calibrator until the Dwell Meter reads on the set line (test leads separated).

(2) Leave selector Switch in the CALIBRATE position, connect the tach-dwell red lead to the distributor terminal of coil and the black lead to a good ground.

(3) Turn ignition switch "ON". Observe dwell meter reading. Meter pointer should be well within the black bar marked "DISTRIBUTOR RESISTANCE". If reading is zero or outside of black bar, crank the engine with the starter until the meter pointer moves as far to right as possible. (This will indicate that breaker points are closed). A reading now within the black indicates a normal distributor primary circuit.

If the reading is outside the black bar, high resistance is present in the distributor primary circuit.

(4) Remove the test lead from the distributor terminal of coil and connect to the following points:

- (a) Distributor primary terminal (outside)
- (b) Distributor primary terminal (inside)
- (c) Breaker point terminal bracket (insulated bracket)
- (d) Ground side of contact points.
- (e) Distributor housing.

(5) Repeat test at each connection until a noticeable change occurs in the meter reading. If a poor connection or faulty lead is indicated, clean, tighten or replace as necessary and repeat test (3).

If faulty contact points are indicated, remove distributor for complete inspection, service, testing and calibration.

39. IDLE RPM TEST

The engine idle rpm setting should be tested and recorded as it is when the vehicle is first brought into the shop for testing. This will assist in diagnosing complaints of engine stalling or complaints of creeping and hard shifting on vehicles equipped with automatic transmissions.

Test procedures are as follows:

(1) Turn the Selector Switch to the CALIBRATE position and adjust the Dwell Calibrator until the Dwell Meter reads on the SET line (test leads separated).

(2) Connect the red lead of the test unit to the distributor primary terminal at the coil and the black lead to a good ground.

(3) Turn the Selector Switch to the 8 LOBE position.

(4) Turn the tachometer rpm switch to the 1000 rpm position.

(5) With the engine at normal operating temperature (off fast idle), momentarily open the throttle and release to make sure there is no bind in the linkage and that the idle speed screw is against its stop.

(6) Note engine rpm on 1000 rpm scale and adjust carburetor idle speed to specifications. See "Fuel System", specifications.

40. DISTRIBUTOR POINT DWELL

The degrees of distributor dwell are the degrees of rotation through which the breaker contact points remain closed. This is also commonly referred to as "dwell angle" or "cam angle".

The correct distributor point dwell is essential for good ignition performance and contact point life.

Test procedures are as follow:

(1) Connect the Tach-Dwell red lead to the distributor terminal of coil and black lead to a good ground.

(2) Turn the Selector Switch to the 8 LOBE position.

(3) Start the engine and operate at idle speed.

(4) Observe the dwell meter reading. If the dwell reading is within "Specifications", the point gap, cam rubbing block and breaker arm are all in satisfactory condition.

If the dwell reading is not within specifications, incorrect point gap, worn cam, worn rubbing block or distorted breaker arm may be indicated.

41. DUAL BREAKER POINTS

Block one set of contacts with a clean insulator and adjust the opposite set of contacts to specifications using the dwell meter.

NOTE: Loosen the stationary contact lock screw just enough, so that the stationary contact can be moved with a slight drag; otherwise it will be difficult to set the contact accurately.

When the one set of contacts has been adjusted for the correct clearance, tighten the stationary contact lock screw.

Block the adjusted set of contacts with an insulator and adjust the remaining set of contacts in the same

manner as the first set. Remove insulator and recheck tightness of the stationary contact lock screw.

If the contacts have been properly adjusted, the dwell should be as specified for two contact sets.

42. DWELL VARIATION

This test indicates the mechanical condition of the distributor. Excessive wear in distributor mechanical parts cause dwell variations which will affect ignition timing.

Test procedures are as follows:

(1) With the engine at idle speed, the vacuum hose disconnected, and with the test leads connected as in Paragraph, "Point Dwell Test", turn the Tachometer rpm Switch to the 5000 rpm position.

(2) Slowly increase the engine speed to 1500 rpm, then slowly reduce to idle speed while observing the dwell meter reading.

If the dwell reading varies more than 2 degrees from initial reading between idle speed and 1500 rpm, probable wear in the distributor shaft, bushings or breaker plate is indicated. Remove distributor for complete inspection and testing on a distributor tester.

NOTE: Dwell variation at speeds above 1500 rpm does not necessarily indicate distributor wear.

IMPORTANT: Dwell and gap of the points must both be within their specified tolerance at the same time. If this cannot be accomplished, it is probable that wrong points are installed or the cam lobes are badly worn.

43. IGNITION TIMING

To obtain maximum engine performance, the distributor must be correctly positioned on the engine to give the proper ignition timing.

The ignition timing test will indicate the timing of the spark at No. 1 cylinder at idle (only).

Test procedures are as follows:

(1) Disconnect the vacuum hose at the distributor.

(2) Connect the secondary lead to the Power Timing Light to No. 1 spark plug, red primary lead to positive terminal of battery and black primary lead to the negative battery terminal.

NOTE: Do not puncture the wires, boots or nipples with test probes. Always use adapters. Puncturing spark plug wires with a probe will damage the wires. The probe can separate the conductor and cause high resistance. In addition, breaking the rubber insulation may permit secondary current to arc to ground.

(3) Start the engine and set the idle to specifications rpm, engine at normal operating temperature (transmission in neutral).

(4) Using a timing light, observe the position of timing mark on the crankshaft damper and check against the specifications.

(5) Loosen the distributor hold down clamp screw and rotate the distributor housing so that the specified timing mark on damper aligns with the specified "BTC" mark on the timing plate. Moving the distributor "clockwise" advances the timing and "counterclockwise" retards the timing.

(6) Tighten the distributor hold down clamp screw after the timing has been set and recheck the timing adjustment with a Power Timing Light.

(7) When the ignition timing is correct, connect the vacuum hose to the distributor.

NOTE: As the engine speed is increased, the timing mark should move down on the vibration dampener below the pointer if advance units are functioning.

SERVICE PROCEDURES

44. DISTRIBUTOR

Removal

(1) Disconnect the vacuum hose at the distributor.

(2) Disconnect the primary lead wire at the coil.

(3) Unfasten the distributor cap retaining clips and lift off the distributor cap.

(4) Scribe a mark on the edge of the distributor housing to indicate the position of the rotor as reference when reinstalling the distributor.

(5) Remove the distributor hold-down clamp screw and the clamp.

(6) Carefully lift the distributor from the engine.

Shaft and Bushing Wear Test

(1) Remove the distributor rotor.

(2) Clamp the ribbed section of the distributor housing lightly in a vise equipped with soft jaws and attach the dial indicator to the body of the distributor with the indicator plunger arm resting against the moveable breaker arm with the rubbing block of the breaker arm on the highest point of the cam lobe (Fig. 80).

(3) Place one end of a wire loop around the top of the distributor shaft. Hook a spring scale in the other end of the wire loop and pull on a line with the plunger of the indicator gauge. Be sure the wire loop on the shaft end is down on the shaft to insure a straight pull and also that the wire loop does not interfere with the indicator or holding bracket. Apply a five pound pull and read the movement of the plunger on the indicator dial. (Be sure the rubbing

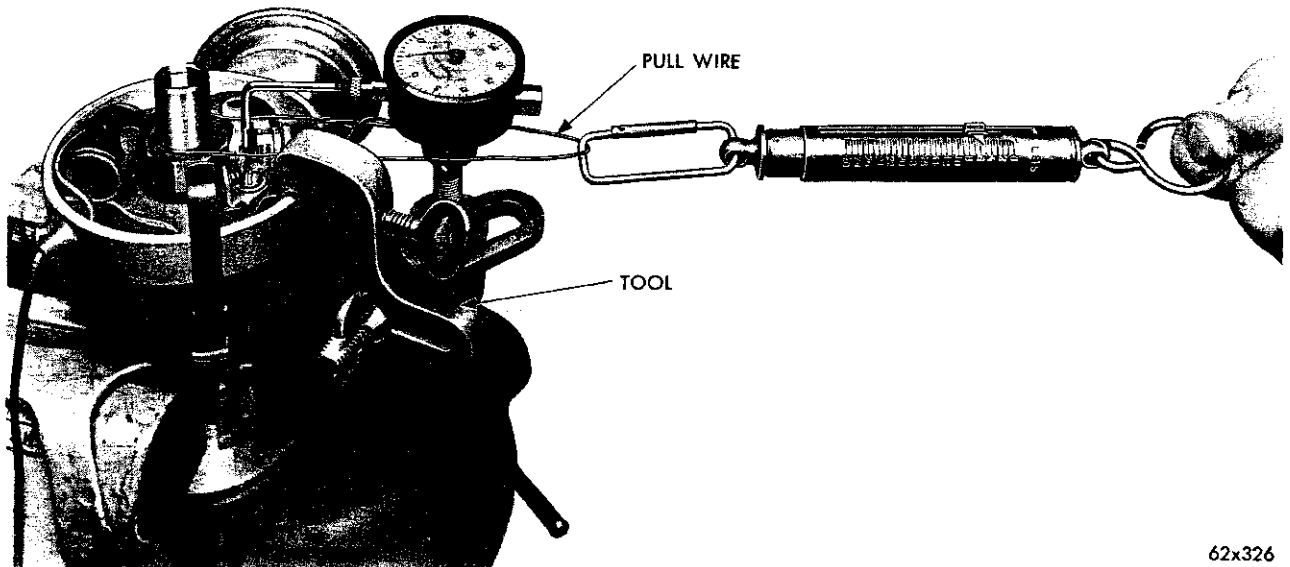

Fig. 80—Shaft and Bushing Wear Test

block of breaker arm is on the highest point of the cam lobe during this test. If the plunger movement exceeds .006 inch, replace the bushings and/or distributor shaft, see "Distributor Disassembly".

Disassembly (Figs. 81 and 82)

(1) Remove the distributor rotor.

NOTE: The distributor cap clamp springs on Chrysler built distributors are held in place by peened metal around the openings and should not be removed.

(2) Remove the retainer attaching the vacuum advance unit to the breaker plate advance arm.

(3) Remove the two screws and lockwashers attaching the vacuum advance unit to the distributor housing and remove the unit.

(4) Remove the primary lead wire and rubber grommet as an assembly. Push the grommet towards the inside of distributor to remove. Do not pull the wire.

(5) Remove the two screws and lockwashers attaching the breaker plate to the housing and lift out the breaker plate, points and condenser as an assembly.

(6) Remove the oil wick from the distributor cam (Fig. 83). Remove the spring clip from the oil well in the cam and remove the cam and yoke assembly and spacer.

If the side play exceeds .006 inch in the "Shaft and Bushing Wear Test", replace the bushings and/or distributor shaft as follows:

(a) Remove the distributor drive collar retaining

pin and slide the collar off the end of the shaft.

(b) Use a fine file to clean the burrs from around the pin hole in the shaft and remove the lower thrust washer.

(c) Push the shaft up and remove it through the top of the distributor body. Remove the upper thrust washer.

(d) Remove the shaft oiler and lift out the oiler wick.

CAUTION: On Chrysler Built distributors, do not drive the bushings out of the housing.

(e) Remove the upper bushing with Tool C-3744 (Fig. 84) by threading the tap securely into the bushing. Place the spacer over the tap. Install the tool nut and, while holding the tap, tighten the tool nut to remove the bushing. Invert the housing and remove the lower bushing in the same manner.

On AutoLite built distributors, place the housing in an arbor press and press out the upper and lower bushings from the bottom of the housing using driver Tool C-3041.

(f) Soak the new bushings in light engine oil for approximately 15 minutes.

(g) Position the new upper bushing with the hole in the bushing up and in line with the oil hole in the housing, then press the bushing into the distributor housing with Tool C-3041 and adapter (Fig. 85). The bushing will measure .094 inch below the top of the housing bore for AutoLite distributors. For the Chrysler built distributors use Tool C-3041 with the flat face of adapter contacting the bushing then press the bushing into the distributor until top

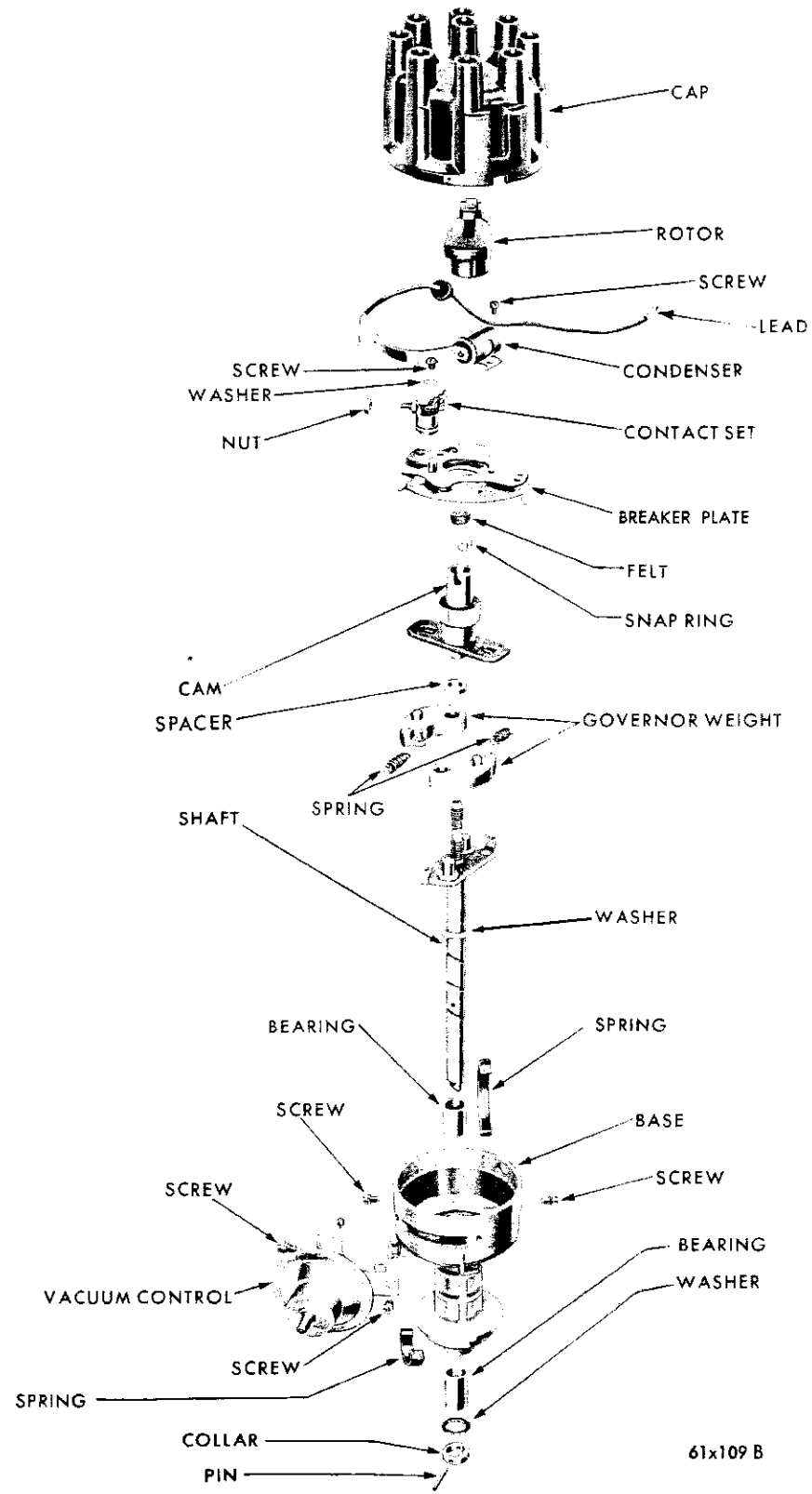

Fig. 81—Distributor—Disassembled View (Chrysler)

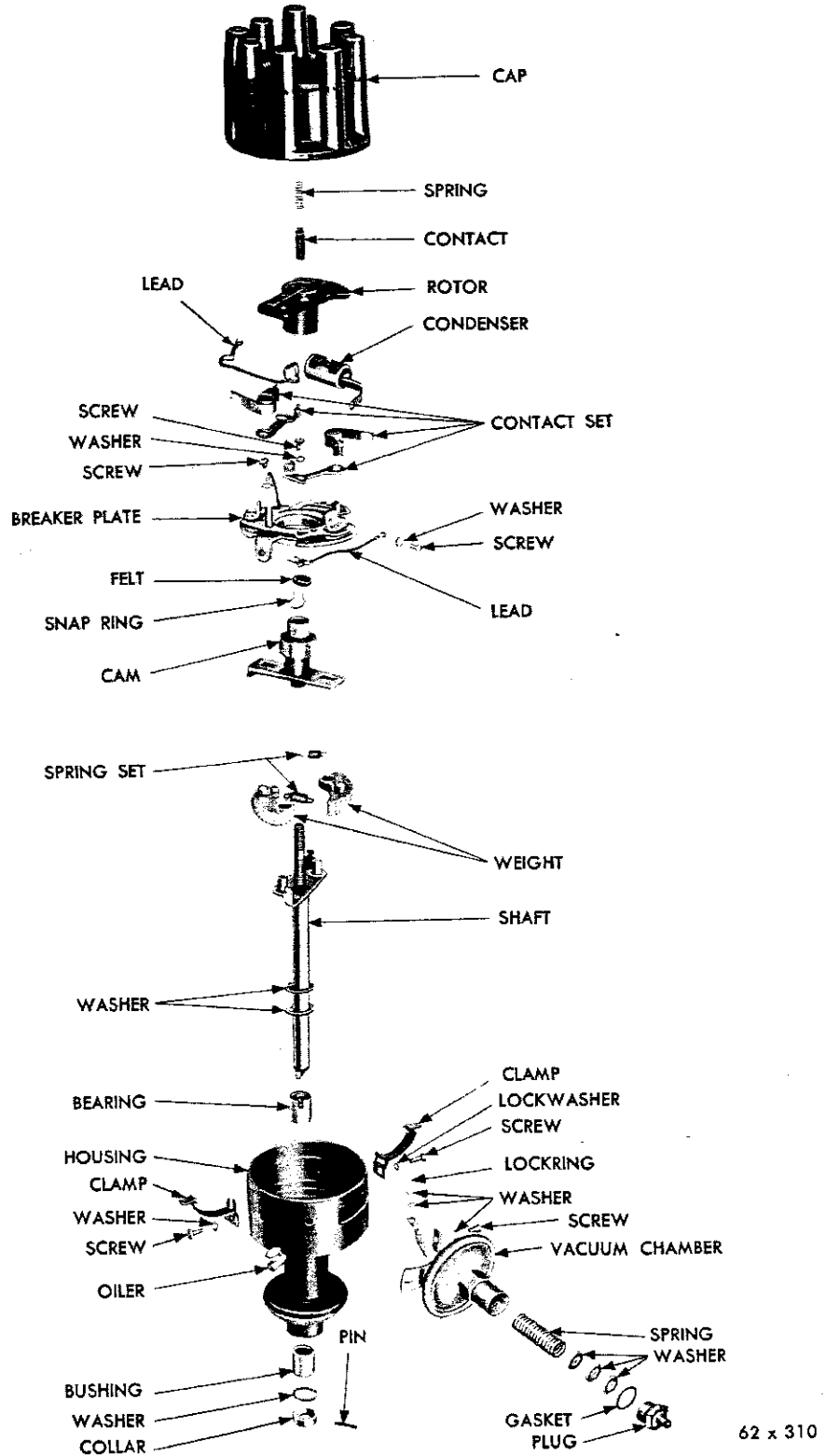

Fig. 82—Distributor—Disassembled View (Auto-Lite)

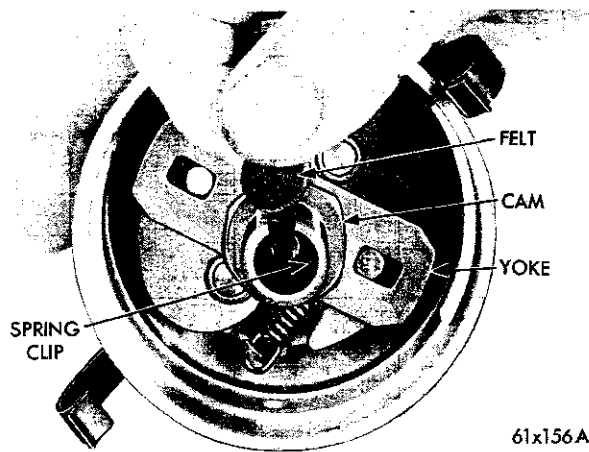

Fig. 83—Removing the Distributor Cam Felt Wick

of bushing is 1.613 inches from top machined face of distributor housing. Place a straight-edge on machined surface of housing and measure from the bottom face of the straight-edge to the top of the bushing. Invert the housing and install the other bushing (Fig. 86) flush with the face of the distributor base.

(h) Insert a $\frac{3}{32}$ inch rod through the housing oiler hole to see if the hole in the bushing indexes with the oiler hole in the housing. If the rod cannot be inserted through the housing and the bushing, drill a $\frac{1}{8}$ " hole through the upper bushing by drilling through the oil wick hole. Remove burrs caused by the drilling operation.

(i) Install the burnishing tool part of C-3041 Tool set and force the burnisher through both the bushings (Fig. 87). The correct bushing inside the diameter is .04995 to .5000 inch.

Assembly

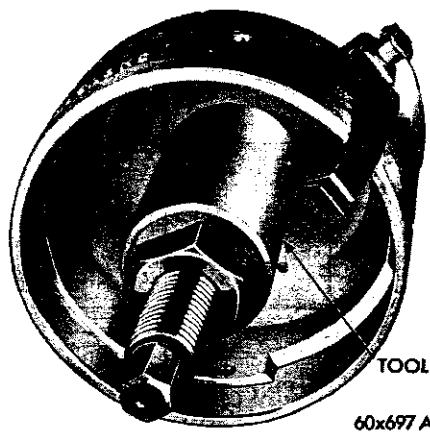

Fig. 84—Removing the Distributor Housing Upper Bushing

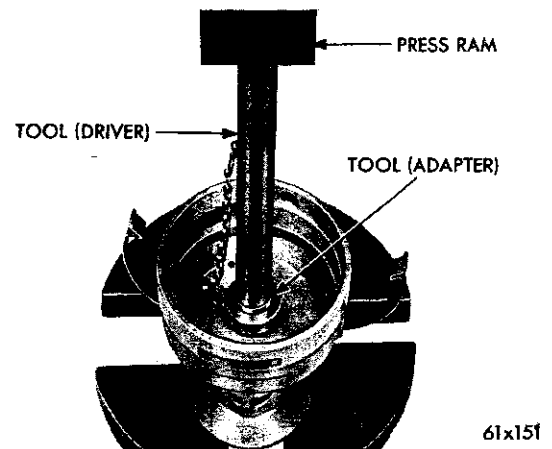

Fig. 85—Installing the Distributor Housing Upper Bushing

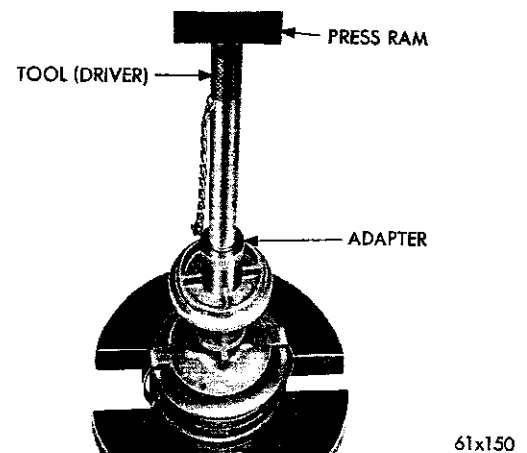

Fig. 86—Installing the Distributor Housing Lower Bushing

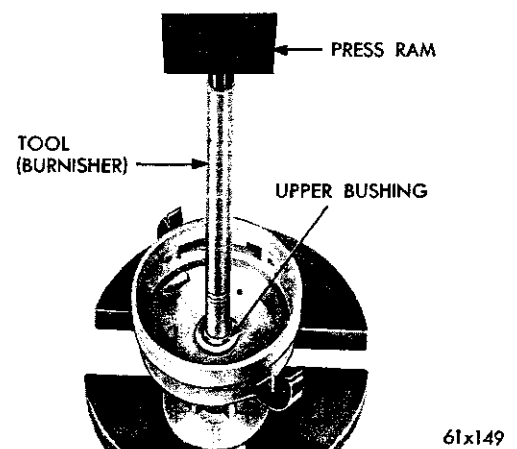

Fig. 87—Burnishing the Distributor Housing Bushings

(1) Test the operation of the centrifugal weight and inspect the weight springs for distortion. Lubricate the governor weights.

(2) Inspect all the bearing surfaces and pivot pins for roughness, binding or excessive looseness.

(3) Install the cam spacer, chamfered end down on the distributor shaft.

(4) Slide the cam and yoke on the distributor shaft, engage the weight lugs with the slots in the yoke (Fig. 88). Install the cam retaining spring clip. Be sure it is properly seated in the groove of the distributor shaft.

(5) Lubricate and install the two concave upper thrust washers for AutoLite distributors or a single flat thrust washer for Chrysler-built distributors. Position the washers on the distributor shaft and slide the shaft into the distributor body. Position the lower thrust washer and drive the collar on the lower end of the shaft. Install the retainer pin.

(6) Install the oiler wick and oiler.

(7) Install the breaker plate assembly. Align the condenser lead, breaker point spring, primary lead and install the attaching screws.

(8) Install the felt wick in the top of the distributor cam.

(9) Attach the vacuum advance unit arm to the breaker plate and install the retainer. Install the vacuum unit attaching screws and washers.

(10) Test the breaker arm spring tension, and adjust the contact gap.

(11) Lubricate the felt pad in the top of the distributor cam with 3 to 5 drops of light engine oil and install the rotor.

45. TESTING BREAKER ARM SPRING TENSION

(1) Hook a spring scale Tool MTU-36 on the breaker arm and pull in a straight line at right angles to the point surfaces (Fig. 89). Take a reading as the points start to separate under the slow and steady pull of the scale. The spring tension should be as

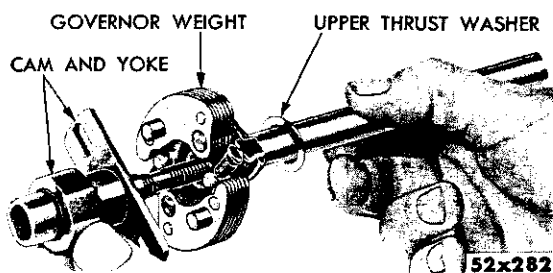

Fig. 88—Distributor Shaft Assembly

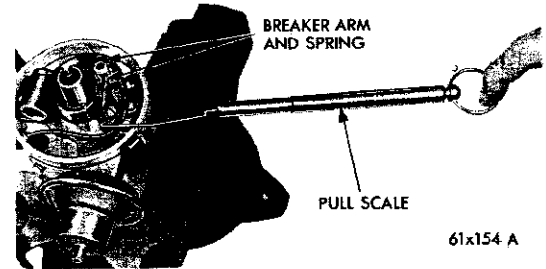

Fig. 89—Testing the Breaker Arm Spring Tension

shown in "Specifications". If the reading is outside these limits, loosen the screw which holds the end of the breaker arm spring, and slide the end of the spring in or out, as necessary.

(2) Tighten the screw and measure the spring tension.

NOTE: Spring tension that is too great, will cause excessive wear on the distributor cam and on the nylon block of the movable breaker arm. Spring tension that is too weak, is unable to keep the points in contact with each other when they close. This is particularly true as engine speed is increased, causing high-speed misfiring.

46. INSTALLING AND ALIGNING CONTACT POINTS

(1) Remove the old contact points and install a new set.

NOTE: Touching the contact point faces with fingers during installation will cause burning of points during operation.

(2) Align the contacts to obtain contact in the center of the points, by bending the stationary con-

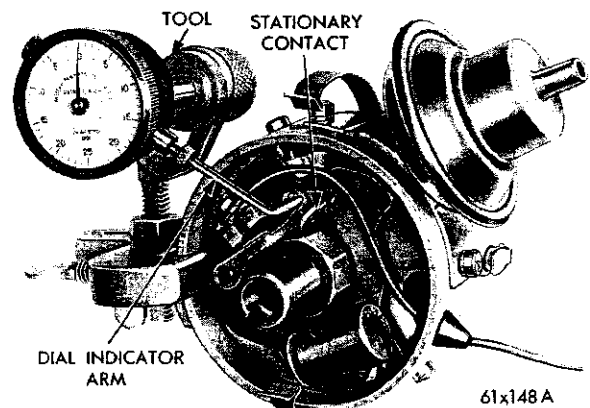

Fig. 90—Adjusting the Point Clearance with a Dial Indicator

tact bracket only. **Never bend** the movable arm to obtain alignment.

(3) After aligning the contact points, readjust the point clearance to specifications using a dial indicator (Fig. 90).

(4) Test the dwell angle to show proper degree of closure. See Paragraph, "Distributor Point Dwell". The lock screw should be loosened just enough so that the stationary bracket can be moved with a slight drag; otherwise, it will be difficult to set the points accurately. After setting the points to correct the gap, tighten the lock screw.

47. DISTRIBUTOR LUBRICATION

(1) Add 3 to 5 drops of SAE 10W oil to the oiler on the outside of distributor base.

(2) Lubricate the felt pad under the rotor in the top of the distributor cam with 3 to 5 drops of SAE 10W oil.

(3) Wipe old grease from surface of the breaker cam. Apply a light film of new distributor cam lubricant number 1473595. **DO not over-lubricate, keep oil and grease away from the breaker points.**

48. TESTING DISTRIBUTOR ADVANCE

Centrifugal Advance Curve

Note the model number of the distributor and refer to the specifications before making this test.

Mount the distributor assembly (less cap and rotor) in a reliable-stroboscope-type distributor tester and proceed with tests as follows:

NOTE: Clamp around the rib section of the distributor housing. The bottom section of the distributor housing is not a machined surface and concentricity would be affected, causing a wobble.

(1) Turn the Tach-Dwell switch to the 8 "LOBE" position and the motor switch to the correct direction of rotation. Refer to "Distributor Advance Specifications" in this manual.

(2) Turn the battery switch "ON".

(3) Regulate the tester speed control to operate the distributor at 200 distributor rpm.

(4) Hold the distributor breaker plate in the full retard position and align the "0" of the distributor tester degree ring with any one of the arrow flashes.

(5) Regulate the tester speed control to operate the distributor at speeds called for under "Specifications" and observe arrow flashes opposite tester degree ring to determine degrees of advance.

(6) If the advance is not according to specifications, corrections can be made by bending the primary and secondary spring on the cam yoke, to increase or decrease the spring tension. The governor

spring tabs can be reached through the access hole at the breaker plate. Rotate the shaft until the proper spring and tab lines up with the access holes. Insert a screwdriver blade through the access hole and bend the spring tab toward the distributor cam to decrease spring tension and advance the park, or away from the distributor cam to increase the spring tension and retard the spark.

NOTE: The light tension spring controls the lower end of the advance curve, and the heavier spring controls the upper end of the advance curve.

Vacuum Diaphragm Leak Test

With the distributor mounted in the distributor tester and with the vacuum unit attached to the distributor, proceed as follows:

(1) Place the thumb over the end of the vacuum pump hose and adjust the regulator control knob to give a reading 20 inches with hose closed off to be sure tester hose does not leak.

(2) Attach the vacuum pump hose to the tube on the vacuum unit. The vacuum gauge should hold on maximum vacuum obtainable if no leaks exist.

(3) Observe the breaker plate while performing the leak test to test response of the breaker plate. There should be instant response to the pull of the diaphragm, moving the plate without a drag or bind.

(4) If leakage is indicated, replace the vacuum unit assembly.

Vacuum Advance Curve

Connect the tester vacuum pump hose to the distributor vacuum advance unit and perform operations 1 through 5 under "Centrifugal Advance Curve". Then proceed as follows:

(1) Turn the tester vacuum pump "ON". Adjust the vacuum pump regulator to vacuum test specifications. See "Specifications" and observe the arrow flashes on the tester degree ring to determine the degrees of advance.

(2) If the vacuum advance is above or below specifications, replace the vacuum advance unit. Retest the vacuum advance curve.

Installation (On the Engine)

(1) Position the distributor on the engine. Align the rotor with marks previously scribed on the distributor housing.

(2) Engage the tongue of the distributor shaft with the slot in the distributor and oil pump drive gear.

NOTE: If the engine has been cranked while the distributor is removed, it will be necessary to establish the proper relationship between the distributor shaft and the No. 1 piston position as follows:

(3) Rotate the crankshaft until the number one piston is at top of the compression stroke.

(4) Rotate the rotor to the position of the number one distributor cap terminal.

(5) Lower the distributor into the opening, connect the primary lead and install the distributor cap. Make sure all high tension wires "snap" firmly in the cap towers. Install the distributor hold-down clamp screw. Tighten the screw finger tight.

(6) Connect the secondary lead of a Power Timing Light to the No. 1 spark plug (using proper adapter). Connect the red primary lead to the positive terminal of the battery and the black primary lead to the negative battery terminal.

(7) Start and operate the engine at 475-500 rpm. Rotate the distributor housing so that the specified timing mark and the pointer are in alignment. (Moving the distributor housing "clockwise" advances the timing and "counterclockwise" retards the timing.

(8) Tighten the distributor clamp screw after the timing has been set and recheck the timing adjustment with a Power Timing Light.

(9) If the timing is correct, connect the vacuum hose to the distributor and remove the timing light from the engine.

49. SPARK PLUGS

Cleaning and Inspection

Remove the spark plugs. Examine the firing ends of the plugs for evidence of oil fouling, gas fouling, burned or overheating conditions. Clean and reset the gaps to .035 inch.

NOTE: Before setting the spark plug gap, file center

electrode flat. Make adjustment by bending the ground side electrode; never bend the center electrode.

Inspect the spark plug cables, coil secondary cable, nipples and cup for cracks, wear and fraying. Always use the neoprene insulating nipples whenever it becomes necessary to replace high tension cables or nipples. Inspect for loose terminals. When installing spark plugs, tighten to 30 foot pounds.

50. IGNITION COIL

The ignition coil is designed to operate with an external ballast resistor.

The ballast resistor is a fixed resistance in the ignition primary circuit. During low speed operation, when the primary circuit current flow as high, the ballast resistor temperature rises, increasing the resistance. This reduces the current flow, thereby prolonging ignition point life. At high speed operation, when the primary current flow is low, the ballast resistance cools off allowing more current flow, which is required for high speed operation. During starter operation, the ballast resistor is bypassed, allowing full battery voltage to the ignition primary circuit.

When testing the coil for output, include the resistor in tests. Inspect the coil for external leaks and arcing. Always make two tests when checking the coil. One when coil is cold, the other after coil has been warmed up.

Test the coil according to the coil tester Manufacturer's instructions. Test the coil primary resistance. Test the ballast resistor resistance. Test the coil secondary resistance. Replace any coil and ballast resistor that does not meet specifications.

PART 5

INSTRUMENTS

Electroluminescent Lighting (Imperial)

51. OPERATION

Electroluminescent panel lighting used in all Imperial Models, achieves a soft uniform glow that illuminates the panel instruments without objectionable intensity or glare. Light level is adjusted by means of a manually controlled knob.

Electroluminescent lighting has no filaments or gases, but instead is composed of laminated layers of material which glow when an alternating current is applied. A typical lamp (Fig. 91) is composed of several layers as follows:

(1) A sheet of vitreous enameling steel forms the instrument back.

(2) A layer of solid ceramic similar to porcelain is applied to the steel sheet.

(3) A layer is then added which has panelescent phosphor suspended in ceramic.

(4) A transparent electrically conducting layer is then added.

(5) A finish layer of transparent glass coating is sprayed on.

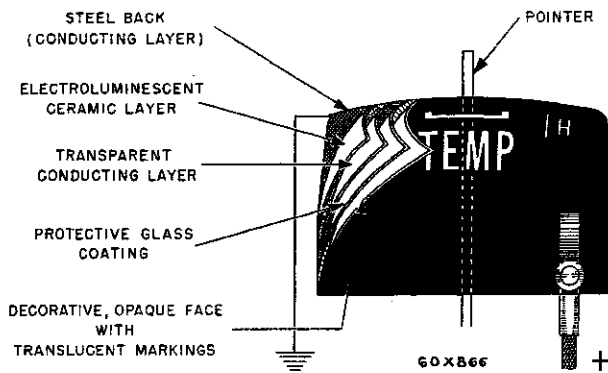

Fig. 91—Electroluminescent Panel Lighting (Typical)

This lamp is electrically a condenser. When A/C potential is applied between the steel plate and the transparent electrically conducting layer, the electric field excites the dielectric causing a solid state, which results in visible light. (The phosphorescent surface acts as a dielectric between the two conducting surfaces and it also has the property of glowing when excited by a high frequency high voltage current). The layer principle is also applied to the pointers, and, as a result the instrument pointers are a light source in themselves, as are the instrument dials.

Electroluminescent is powered from a transistor oscillator, which converts the 12 volt D/C to 200 volts A/C at 250 cycles per second. This power pack (Fig. 92) is mounted on the cowl side panel underneath the instrument panel.

The main components of the electroluminescent panel lighting is composed of:

- (1) The A/C power pack.
- (2) The individual instrument lighting.
- (3) The connecting wiring.

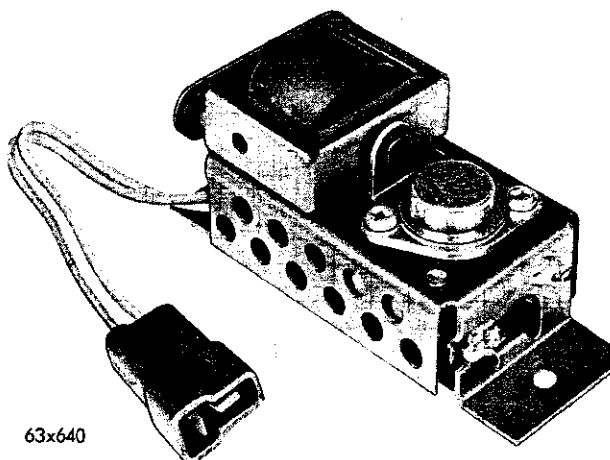

Fig. 92—Power Pack Unit

52. INSTRUMENT TESTING (With Tool C-3764) (Fig. 93)

WARNING: Before connecting any test equipment, always turn the instrument panel switch "OFF". Failure to do this might result in your becoming startled by an electric shock from the high voltage in the instrument power unit. The terminals are the protective type and this should not occur unless you inadvertently touch the terminal of disconnected socket. However, due to the low wattage, it will not harm you.

(1) Turn on the instrument panel switch and observe the instrument lighting. If any portion of the instrument panel does not light, the unlighted lamps are open and the complete instrument should be replaced.

(2) If the entire panel fails to light, turn off the instrument panel switch and install the tester tool at the power pack by disconnecting the connectors and plugging in the tool connectors. Ground the black wire to a good ground on the instrument panel.

NOTE: The caps on the end of the tester indicate the high and low voltage indicator lamps. Red indicates high voltage A/C. Black indicates low voltage D/C.

(3) Turn on the instrument panel light switch. If the D/C and A/C indicators both glow, it indicates the A/C power supply is operating satisfactory.

(4) If the D/C indicator glows but the A/C does not, the power unit (Fig. 92) is not operating and should be replaced.

(5) If neither the D/C or A/C indicator glows, it indicates the D/C circuit (orange lead) is incomplete. Test with D/C voltmeter to locate the failure on the D/C input side of the power unit.

(6) If both the D/C and A/C indicators glow but the panel does not light up test for a short, circuited lamp by disconnecting each lamp in succession and touch the test prod on the white test lead from the

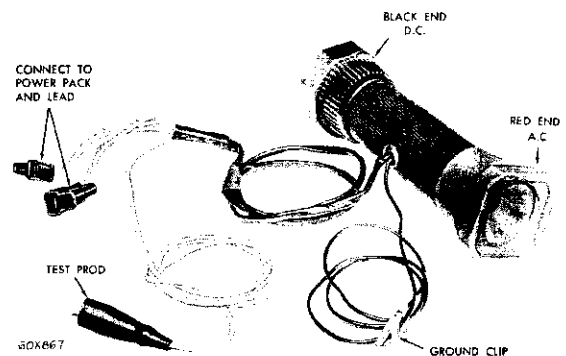

Fig. 93—Testing Tool C-3764

tester to the terminal of each of the lamp receptacles.

A good lamp will light up when its terminal is contacted by the white lead test prod. A short circuited lamp will not light up and the instrument must be replaced.

NOTE: One shorted lamp will prevent the entire panel from lighting.

(7) There is always a possibility that more than one lamp might be shorted at the same time. In this case, the panel will stay dark after the new instrument is installed. Continue to test the balance of the lamps that were not tested before to find additional short circuited lamps.

PART 5 GAUGES

53. OPERATION

Thermal type gauges operate on a principle of constant voltage being applied, and are sensitive only to changes in fuel level, oil pressure or temperature.

The constant voltage is connected in parallel to the gauges and provides the same regulated voltage to the gauges.

The constant voltage is provided through the use of a voltage regulator contained inside the fuel gauge case on Chrysler models and inside the temperature gauge on Imperial models.

The terminals on the gauge that houses the constant voltage regulator internally is marked as follows:

“A”—is the output terminal for the controlled voltage from the regulator.

“T”—is the 12 volt input voltage terminal to the voltage regulator.

“S”—is the terminal for the connection to the sending unit.

The gauges (related to the thermal system) that do not contain the regulator will have only the controlled voltage terminal and the terminal for the connection to the sending unit.

Tank Unit

A float arm is hinged to allow the float to raise or lower dependent on the fuel level. The float connects to a variable resistance that provides a change in the resistance with any up or down motion of the float through a wiping contact in the gauge body (Fig. 94).

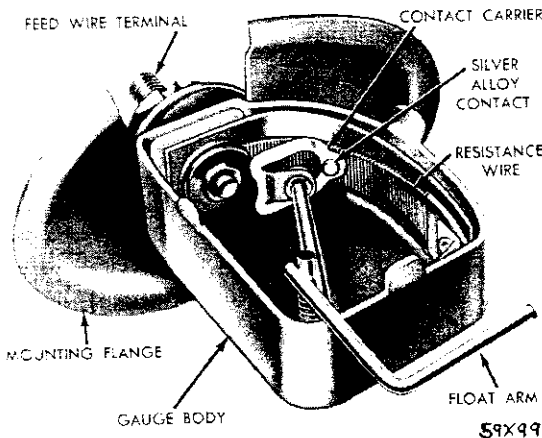

Fig. 94—Tank Unit (Typical)

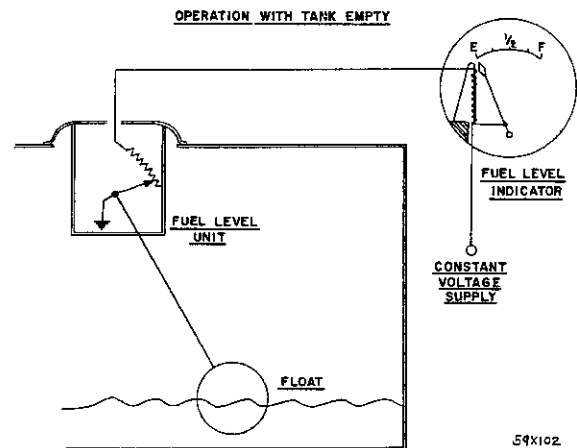

Fig. 95—Operation with Tank Empty

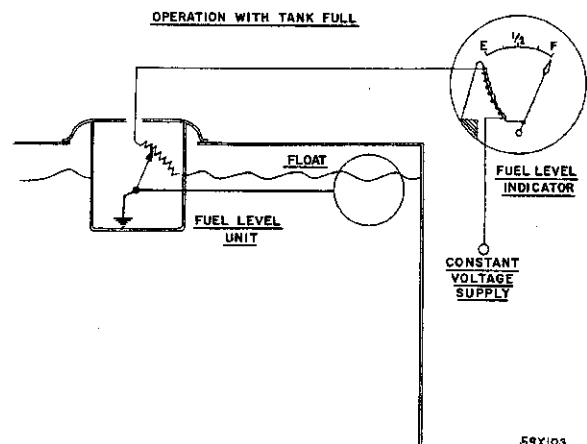

Fig. 96—Operation with Tank Full

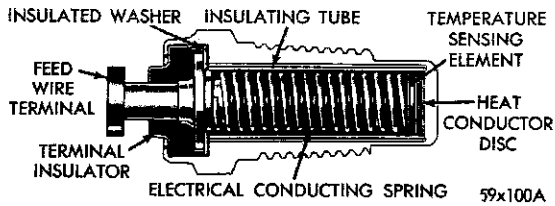

Fig. 97—Engine Temperature Sending Unit

54. FUEL LEVEL INDICATING SYSTEM

Turning the key on connects the system to the battery or charging system voltage. The voltage from the car battery or charging system is regulated by a constant voltage limiter to a constant voltage of approximately 5 volts D.C.

When the fuel level is low or empty, the resistance is increased which decreases the current flow and consequently positions the panel gauge pointer to low or empty (Fig. 95).

When the tank is full, the float level is at the top, the minimum resistance is in the circuit and the flow of current in the circuit is high. The panel gauge pointer will be moved across the dial to indicate a full tank (Fig. 96).

Engine Temperature Sending Unit (Fig. 97)

This unit like the fuel level tank unit operates on a principle of varying resistance.

The Temperature Indicating System

The operation of the temperature indicating system is identical in operation with fuel system with the exception of the method of varying the resistance of the sending unit.

When the engine is cold the resistance of the disc in the temperature sending unit is high. Low temperature will be indicated (Fig. 98).

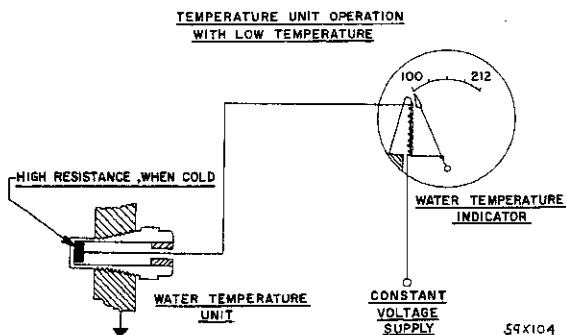

Fig. 98—Operation at Low Temperature

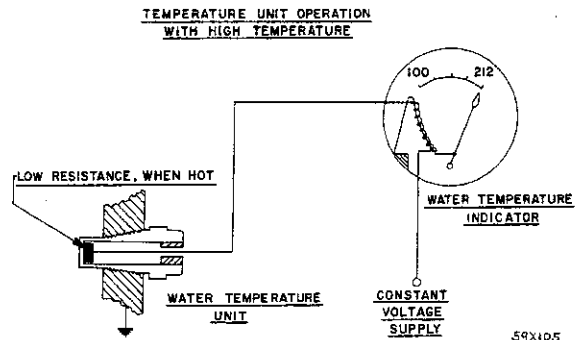

Fig. 99—Operation at High Temperature

As the engine temperature increases the resistance of the temperature sending unit disc starts to decrease. A resultant increase in the current flow will occur causing the gauge pointer to indicate the increase in engine temperature (Fig. 99).

55. INSTRUMENT CLUSTER BULB REPLACEMENT—CHRYSLER TC-1, TC-2, TC-3

All the bulbs in the instrument cluster are contained in plug-in sockets into the printed circuit. The bulbs can be reached from under the instrument panel. To remove the socket turn it 1/4 turn counter-clockwise and pull out. For replacement bulb number see "Bulb Chart".

56. INSTRUMENT CLUSTER AND SPEEDOMETER HEAD

Removal—Imperial

- (1) Disconnect the battery ground cable.

NOTE: If vehicle is equipped with either a heater or air conditioning, or both, it will be necessary to remove the defroster and spot cooler hoses.

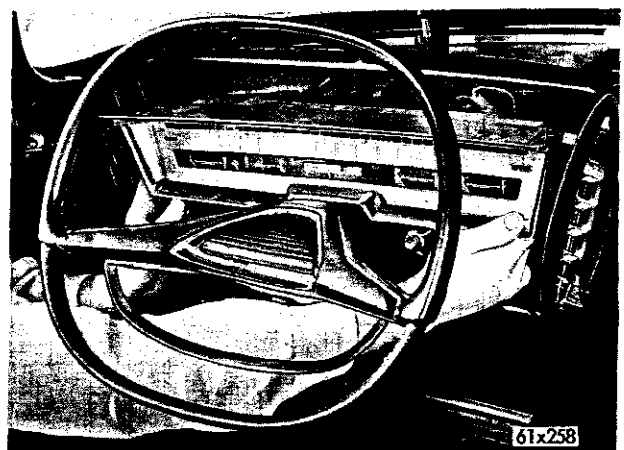

Fig. 100—Removing the Instrument Cluster (Imperial)

(2) Disconnect the speedometer cable at the speedometer head.

(3) Disconnect the odometer reset cable at the instrument panel cluster.

NOTE: To avoid scratching the paint finish on the instrument panel when the instrument cluster is removed, it is recommended that several strips of masking tape be placed on each side of the steering jacket tube.

(4) Remove the five screws securing the instrument cluster to the instrument panel. Carefully remove the instrument cluster (Fig. 100) by tilting the lower end of the cluster outward.

NOTE: For speedometer or complete cluster removal, disconnect all electrical connections. Remove the cluster to the work bench for further disassembly.

Installation

(1) Connect all electrical connections that were disconnected at removal.

(2) Carefully install the instrument cluster in position on the instrument panel, and install and tighten the five instrument cluster to instrument panel attaching screws.

(3) Connect the speedometer and odometer cables to the instrument panel cluster. Make sure that the speedometer cable is properly retained in the attaching clips provided and that it is free of any sharp bends.

NOTE: If vehicle is equipped with either a heater or air conditioning, or both, connect the defroster and spot cooler hoses.

(4) Connect the battery ground cable.

57. INSTRUMENTS

Removal—Imperial TY-1

(1) Disconnect the battery ground cable.

NOTE: The following instruments and switches can be removed and installed from underneath the instrument panel without removing the instrument cluster. If vehicle is equipped with either a heater or air conditioning, or both, it will be necessary to remove the defroster and spot cooler hoses.

(2) Disconnect the wires at the instrument to be replaced.

(3) **Oil Pressure Gauge:** Remove the one attaching screw at the outer end holding the oil pressure gauge. Remove the center screw attaching both the oil pressure gauge and ammeter, then carefully remove the oil pressure gauge.

(4) **Ammeter:** Remove the one attaching screw at the outer end holding the ammeter. Remove the center screw attaching both the ammeter and oil

pressure gauge, then carefully remove the ammeter.

(5) **Fuel Gauge:** Remove the one attaching screw at the outer end holding the fuel gauge. Remove the center screw attaching both the fuel gauge and the temperature indicator, then carefully remove the fuel gauge.

(6) **Temperature Indicator:** Remove the one attaching screw at the outer end holding the temperature indicator. Remove the center screw attaching both the temperature indicator and the fuel gauge, then carefully remove the temperature indicator.

Installation

(1) **Temperature Indicator:** Carefully install the temperature indicator in position and start the center fuel gauge and temperature indicator attaching screw then install the one attaching screw at the outer end. Tighten both attaching screws. Connect the instrument wires.

(2) **Fuel Gauge:** Carefully install the fuel gauge in position and start the center temperature indicator and fuel gauge attaching screw, then install the one attaching screw at the outer end. Tighten both attaching screws. Connect the instrument wires.

(3) **Ammeter:** Carefully install the ammeter in position and start the center ammeter and oil pressure gauge attaching screws, then install the one attaching screw at the outer end. Tighten both attaching screws. Connect the instrument wires.

(4) **Oil Pressure Gauge:** Carefully install the oil pressure gauge in position and start the center oil pressure gauge and the ammeter attaching screw, then install the one attaching screw at the outer end. Tighten both attaching screws. Connect the instrument wires.

NOTE: After each instrument is installed, connect the battery cable, and test the operation of the instrument removed. If the car is equipped with either heater or air conditioning, or both, connect the defroster and spot cooler hoses.

58. HEADLAMP SWITCH

Removal—Imperial TY-1

(1) Disconnect the battery ground cable.

(2) Remove the headlamp switch knob by releasing the retainer on the body of the switch. (Knob must be in the full "OUT" position before the knob stem can be released).

(3) Remove the switch chrome bezel nut.

(4) Remove the switch chrome plate.

(5) Remove the switch back dial plate and the dial lamp.

(6) Remove the switch retaining nut.

- (7) Remove the light switch from the panel.
- (8) Disconnect the connector plug.

Installation

- (1) Connect the connector plug and position the light switch on the instrument panel.
- (2) Install the light switch retainer nut.
- (3) Install the switch back dial plate and the dial lamp.
- (4) Install the switch chrome plate.
- (5) Install the switch chrome bezel nut.
- (6) Install the headlamp switch knob and stem.
- (7) Connect the battery cable.

59. WINDSHIELD WIPER AND WASHER SWITCH

Removal—Imperial

- (1) Disconnect the battery ground cable.
 - (2) Loosen the set screw and remove the control knob and automatic windshield washer control stem.
- NOTE: Use care when removing the windshield wiper control so as not to damage washer control stem.**
- (3) Remove the bezel nut and the dial plate.
 - (4) Remove the back dial plate and the dial lamp to uncover the switch retaining nut, remove the nut.
 - (5) Remove the switch from the rear of the instrument panel.
 - (6) Disconnect the wires and connections and remove switch.
 - (7) Remove washer switch from wiper switch.

Installation

- (1) Install the washer switch on wiper switch.
- (2) Connect the wires and connections.
- (3) Position the switch on instrument panel and install and tighten switch retaining nut.
- (4) Install the dial lamp and dial back plate.
- (5) Install the dial plate and bezel nut.
- (6) Position the washer control stem and install control knob and tighten set screw.
- (7) Connect the battery cable.

60. IGNITION SWITCH

Removal—Imperial

- (1) Disconnect the battery ground cable.
- (2) Remove the switch bezel nut.
- (3) Remove the dial plate and back dial.
- (4) Remove the dial lamp and switch retaining nut.
- (5) Remove the switch from rear of instrument panel.
- (6) Disconnect the connector plug and remove switch assembly.

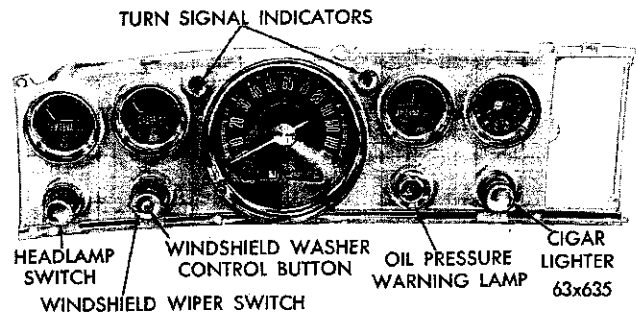

Fig. 101—Cluster Removed Front View (Chrysler)

Installation

- (1) Connect the connector plug.
- (2) Position the switch on instrument panel.
- (3) Install the switch retaining nut.
- (4) Install the switch dial lamp and dial face.
- (5) Install the dial plate.
- (6) Install the switch bezel nut.
- (7) Connect the battery cable.

61. CLUSTER

Removal from Panel (Chrysler TC-1, TC-2, TC-3) (Figs. 101 and 102)

NOTE: The instruments and printed circuits can be serviced after the instrument cluster is removed from the instrument panel.

CAUTION: Disconnect the battery cable at the battery negative terminal before removing cluster.

- (1) Cover the steering column jacket tube area between the steering wheel and the instrument panel with masking tape to avoid scratching the paint finish.
- (2) Remove the screws attaching the upper and lower moldings at the center of the instrument panel. Remove the heater bezel and disconnect the Bowden

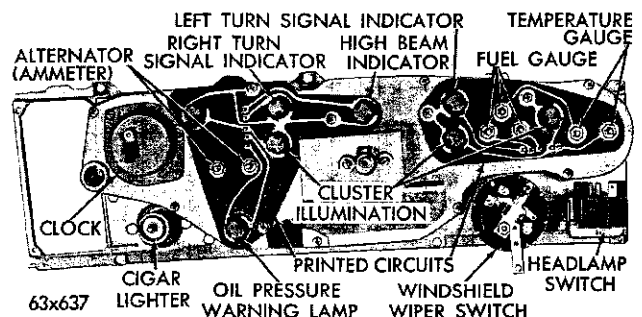

Fig. 102—Cluster Removed Rear View (Chrysler)

cable, the vacuum lines, and the wiring to the heater control switch.

(3) Remove the screws attaching the instrument panel lower hood to the instrument panel and remove the panel hood.

(4) Loosen the Allen set screw and remove the wiper switch knob. Remove the wiper switch retaining bezel using spanner wrench Tool C-3824 and push the wiper switch out of the instrument cluster.

(5) Remove the six screws attaching the instrument cluster to the instrument panel. The six screws are all visible from the front of the instrument cluster. Three screws across the top of the instrument cluster and three screws in the instrument cluster lower chrome molding.

(6) Pull the instrument cluster forward to expose the speedometer cable. Disconnect the speedometer cable at the speedometer.

(7) Roll the instrument cluster down onto the steering column jacket tube and disconnect the two printed circuit multi-connectors, the heater switch connectors, the cigar lighter wire, the headlamp switch connector, and the lead wires to the ammeter.

(8) Remove the instrument cluster to the work bench for repairing or replacing of the instruments and printed circuits.

Installing Cluster—Chrysler
(Figs. 103 and 104)

CAUTION: The battery cable to the battery negative terminal must be disconnected before installation of cluster.

(1) Position the instrument cluster on the steering column jacket tube in front of the cluster opening in the instrument panel.

(2) Connect the heater or air conditioning vacuum hoses to the heater or air conditioning vacuum control switch.

(3) Connect the two printed circuit multi-con-

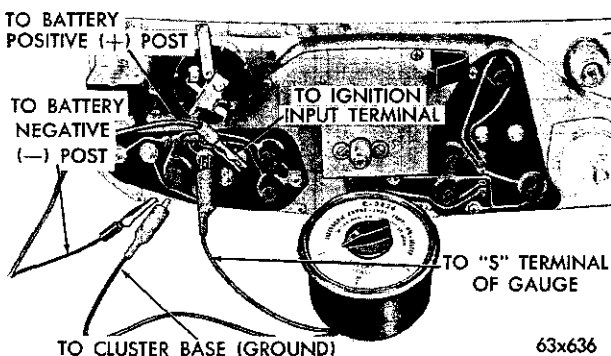

Fig. 103—Testing Gauge with Tool C-3826 (Chrysler)

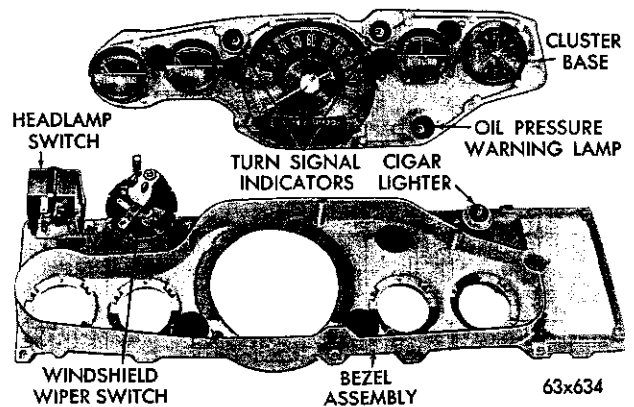

Fig. 104—Cluster Base with Instruments (Chrysler)

nectors and the lead wires to the ammeter. Tighten the nuts on the ammeter studs securely. Connect the headlamp switch connector, cigar lighter connector and heater switch connectors.

(4) Seat the speedometer cable correctly in the speedometer and tighten the knurl securely. Connect the bowden cable to the heater or air conditioning control lever.

(5) Position the wiper switch in the instrument cluster and install the wiper switch retaining bezel, using spanner wrench Tool C-3824.

(6) Install the wiper switch knob. Tighten the Allen set screw in the switch knob securely.

(7) Roll the instrument cluster into position in the instrument panel and install the six attaching screws.

(8) Hold the instrument panel lower hood in position and install the four attaching screws.

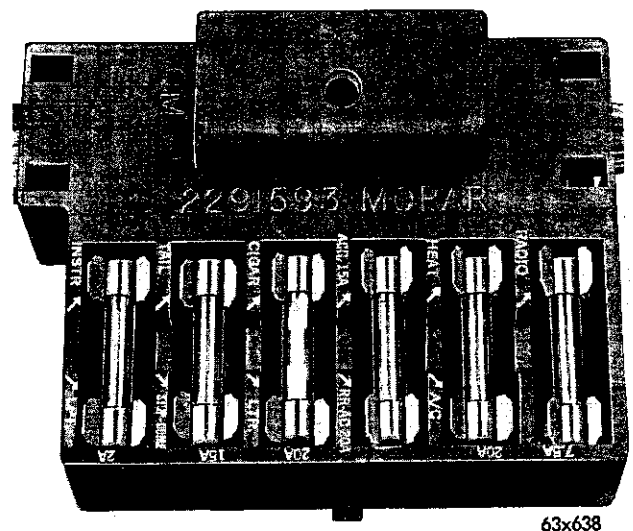

Fig. 105—Fuse Block

(9) Install the screws attaching the upper and lower moldings at the center of the instrument panel.

(10) Connect the battery cable to the battery negative terminal.

(11) Check instrument cluster operation.

62. TESTING GAUGES IN VEHICLE

Testing Voltage Limiter

Test the voltage at the output (A) terminal of the constant voltage limiter. A steady voltage of approximately 12 volts indicates limiter is malfunctioning.

A voltage regulator that is operating properly should normally have a voltage at the output terminal that is fluctuating between 0 and 7.0 volts.

Testing Fuel Gage

Disconnect the lead wire at the tank sending unit.

Connect one lead wire of C-3826 gauge tester to the disconnected lead wire. Connect the other lead wire of the tester to a good ground.

Place the pointer of the tester on the "L" position and turn the ignition switch to "on". The gauge should show "E" or minus $\frac{3}{32}$ inch. **This tolerance permits a small reserve of fuel at the "E" position.**

Place the pointer of the tester on the "M" position, the fuel gauge should slowly advance to the $\frac{1}{2}$ posi-

tion plus or minus $\frac{1}{16}$ inch. Place the pointer of the tester on the "F" position, the fuel gauge should advance to the "F" position plus or minus $\frac{1}{16}$ inch.

If the gauge responds to the above tests but does not respond when the wire is connected to the tank unit, the trouble is in the tank unit. If the gauge does not respond to the tests, indications are of possible loose connections, broken wire, or a defective gauge.

63. FUSE BREAKER (Fig. 105)

The fuse block is located at approximately the center, forward edge of the instrument panel and is retained to the instrument panel lower reinforcement by a self tapping screw.

In the fuse block are mounted the radio, cigar lighter, air-conditioner or heater, tail-stop-dome light, and accessory fuses. The fuse capacity is printed on the fuse block as an aid to replacement requirements.

64. CIRCUIT BREAKER

As a safety precaution, circuit breakers are used for the headlamps and wiper circuits. They insure that these essential services will continue to function if an intermittent short circuit occurs.

PART 6

LIGHTING SYSTEM

65. DUAL HEADLAMPS

The dual headlamp system consists of four sealed beam headlamps.

The two outer lamps are of the two filament type for low and high beam and are marked by a numeral 2 moulded in the lamp lens.

The two inner lamps have only one filament and are marked with a numeral 1 molded in the glass.

The lamps cannot be installed wrong as the mounting lugs for the number one (1) and the number two (2) lamps are offset at different angles.

The number one (1) lamp provides the high intensity "reach" down the highway and the off focus filament in the number 2 lamp provides the "body" light which illuminates the side of the road, ditches, etc.

66. AIMING THE HEADLAMPS

Pre-Aiming Instructions

- (1) Test the dimmer switch for faulty operation.
- (2) **Test the high beam indicator:** Indicates that high beam is in operation when lighted.

(3) **For badly rusted or defective headlamp assemblies:** These conditions must be corrected before a satisfactory adjustment can be made.

(4) Place the vehicle on a level floor.

(5) **Measure the front suspension height:** Adjust to specifications as necessary.

(6) Inspect the tire inflation.

(7) Rock the vehicle sideways to allow the vehicle to assume its normal position.

(8) If the gasoline tank is not full, place a weight in the trunk of vehicle to simulate the weight of the gasoline normally carried in the tank (6 $\frac{1}{4}$ pounds per gallon).

(9) There should be no other load in the vehicle other than the driver or a substituted weight of approximately 150 pounds placed in the driver's position.

(10) Remove the headlamp front trim panel. Do not remove the seal beam retainer rims.

(11) Thoroughly clean the headlamp lenses.

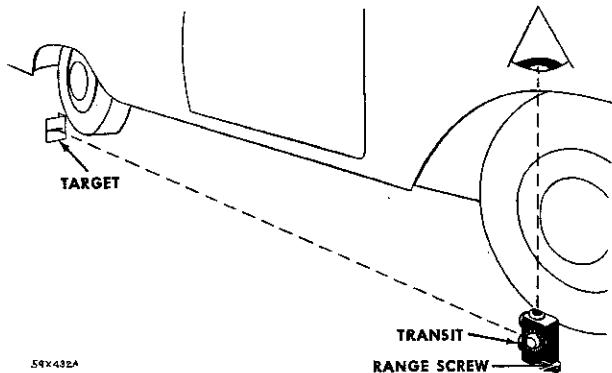

Fig. 106—Determining the Slope of the Floor (Typical)

Compensating the Aimers

(1) Place the transit on the floor in line with a vertical center line of the right front wheel (Fig. 106). Place the split image target in like position at the right rear wheel.

(2) Adjust the range screw on the transit until the target split image coincides or merges into one unbroken line.

NOTE: Make sure that the line of sight is perpendicular from the eye to the viewing port of the transit and that target image is centered in the viewing port of the transit.

(3) Turn the dial on the side of the transit until the bubble in the spirit level is centered.

(4) When the bubble is centered, not “plus” or “minus” reading on the compensator scale. This figure indicates the degree of slope of the floor and must be transferred to each aimer as follows:

(5) With a screwdriver, turn the adjusting slot of the floor level compensator in each aimer, until the correct plus or minus figure (or fractional part) appears in the proper window (Fig. 107).

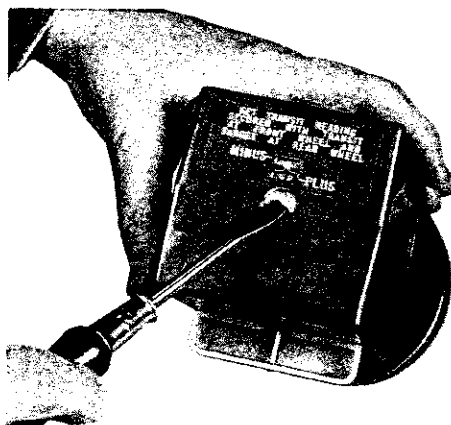

Fig. 107—Adjusting the Floor Level Compensator in the Aimers

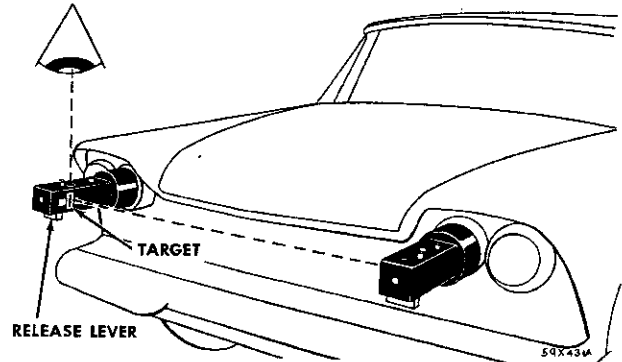

Fig. 108—Mounting and Adjusting the Aimers (Typical)

Mounting and Adjusting the Aimers (Figure 108)

If the aimers are suspected of being out of adjustment refer to Paragraph 66 “Testing and Adjusting Aimer Calibration.”

(1) While holding an aimer in alignment with the lens of one outer headlamp, bring the aimer up to and against the headlamp lens.

NOTE: Make certain that the headlamp lens pads are making full contact with the aimer mounting flange and that the aimer target is facing inboard.

(2) Push the release lever forward (to expel air from the suction cup) and while holding the aimer firmly against the headlamp aiming pads, pull the release lever back until the spring lock engages in the slot.

(3) Mount the second aimer on the other outer headlamp, in the same manner.

(4) On each aimer, set the pointer to the numeral 2 on the DOWN side of the DOWN UP scale.

(5) On each aimer position the pointer of the RIGHT LEFT scale at 2 Right.

67. TESTING HEADLAMP AIM

Follow the instructions as outlined in Paragraph “Aiming the Headlamps” and proceed as follows:

NOTE: Do not remove the headlamp rims.

Horizontal Test

Turn the RIGHT LEFT scale knob until the split images is in alignment. If the RIGHT or LEFT portion of the scale exceeds the following values, the lamps should be aimed.

Values given represent inches at 25 feet.

	RIGHT	LEFT
No. 1 UNIT	4	4
No. 2 UNIT	4	0

Vertical Test

Turn **DOWN-UP** scale knob until the spirit level is centered. If **DOWN** or **UP** portion of the scale exceeds the following values, the lamps should be aimed.

	DOWN	UP
No. 1 UNIT	½ to 3½	0
No. 2 UNIT	½ to 3½	0

**68. ADJUSTING THE HEADLAMPS
(Fig. 109)****Horizontal Adjustment**

(1) With the pointer of the **RIGHT-LEFT** Scale still set at **ZERO**, sight through the aimer viewing port.

Make sure that the line of sight is perpendicular from the eye to the viewing port of the aimer and that the target image is centered in the viewing port of the aimer.

(2) While sighting through the viewing port of the aimer, turn the horizontal adjusting screw (Fig. 109) on the headlamp until the split image target line merges into one unbroken line. To remove the backlash, be sure to make a final adjustment by turning the headlamp horizontal adjusting screw in a clockwise direction.

(3) Make the horizontal adjustment on the other outboard headlamp in the same manner.

(4) Remove the aimers, from the outboard headlamps, by releasing the spring lock at the rear (bottom) of the aimer and pushing the release lever forward. Do not attempt to remove the aimers by pulling them away from the headlamp lens — slide the suction cup downward and away from the lens.

Vertical Adjustment

(1) Turn the vertical adjusting screw on the headlamp in a counter-clockwise direction to bring the

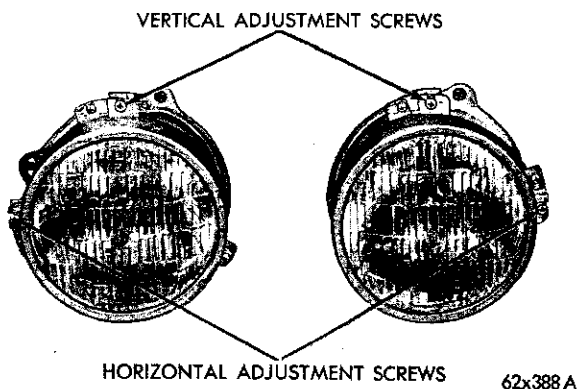

Fig. 109—Headlamp Adjustment Points (Typical)

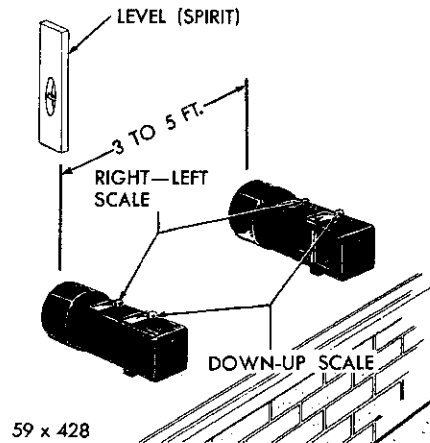

Fig. 110—Inspecting the Aimer for Calibration

bubble of the spirit level on the aimer to the vehicle side of center. Use care to avoid disturbing the installed position of the aimers. Then turn the screw clockwise until the bubble is centered for correct aim and elimination of backlash.

(2) Make the vertical adjustment on the other outer unit in the same manner.

(3) Recheck the target alignment on each side and readjust the horizontal aim, if necessary.

Proceed to adjust the inner units by following the instructions as outlined for the outer headlamps. Install the headlamp trim panels, when the adjustments have been performed.

**Testing and Adjusting Aimer Calibration
(Fig. 110)**

(1) Using a carpenter or stone mason level of known accuracy, locate a true vertical plate glass window or smooth surface.

(2) Set the **DOWN-UP** pointer on **DOWN 2**.

(3) Set the **RIGHT-LEFT** pointer and the floor level compensator at "0".

(4) Secure the aimers to the glass or smooth surface three to five feet apart so that the split image targets can be located in the viewing ports.

(5) If the bubble is centered in the vial, the vertical calibration is correct. If the bubble is not centered, make the down-up adjustment by rotating level adjusting screw until the bubble is centered in the spirit level.

(6) The horizontal aim is correct if the targets on opposite aimers are aligned in the viewing ports. If the targets are not aligned in the viewing ports, rotate the mirror adjusting screw until the target split image becomes aligned.

69. HEADLAMP SEALED-BEAM REPLACEMENT

Lens, filament and reflector are sealed into one unit which can be removed as follows:

- (1) Remove the screws from the headlamp panel and remove the panel.
- (2) Remove the screw from the interior retaining ring, and remove the ring.

NOTE: Do not disturb the headlamp aiming screws.

- (3) Pull out the sealed-beam unit and disconnect the connector, pulling it straight off.
- (4) Install the new sealed-beam unit.
- (5) Install the unit retaining ring and headlamp panel.

NOTE: Each lamp in the dual headlamp assembly can be removed in the above manner.

DIRECTIONAL INDICATORS

70. DIRECTIONAL SWITCH— Imperial TY-1

Removal

- (1) Disconnect the cable at the battery negative post.
- (2) Remove the two screws from the underside of the steering wheel and remove the horn blowing actuator and steering wheel cover.
- (3) Disconnect the horn wire at the horn blowing switch.
- (4) Remove the four screws and insulators and remove the horn blowing switch (Fig. 111).
- (5) Remove the four screws and remove the horn blowing switch mounting plate. (Fig. 112).
- (6) Loosen the steering wheel nut several turns and install the Steering Wheel Puller Tool C-3428 (Fig. 113) and remove the steering wheel nut and steering wheel.
- (7) Remove the directional switch lever (Fig. 114).
- (8) Remove the steering column lower cover.
- (9) Remove the two screws and disconnect the switch wires at the connection and remove the directional switch and wires.

Installation

- (1) Position the directional switch, install the attaching screws and wire connections.
- (2) Install the steering column lower cover.
- (3) Install the directional switch lever.
- (4) Install the steering wheel and steering wheel nut, tighten the nut to 40 foot-pounds torque. Test

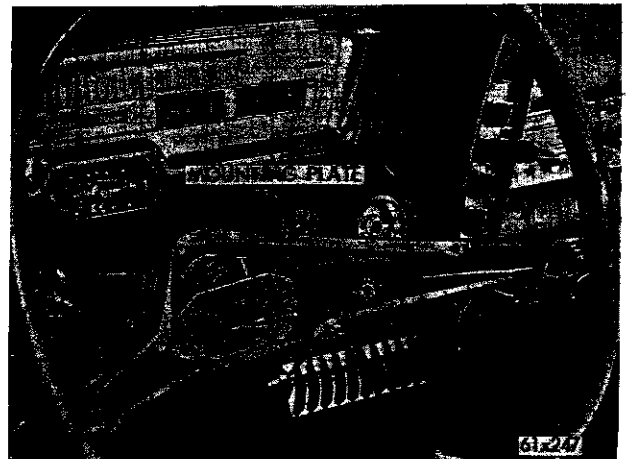

Fig. 112—Horn Blowing Ring Mounting Plate (Typical)

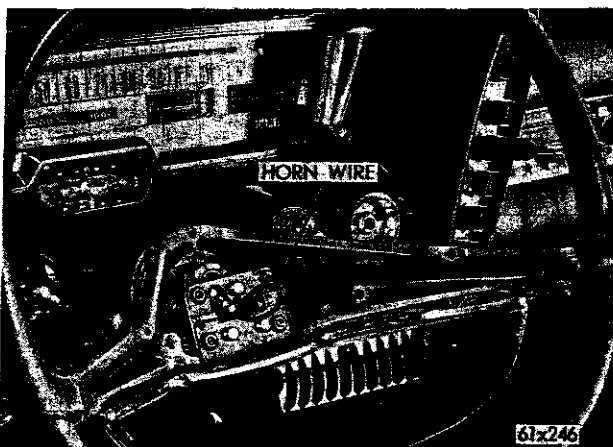

Fig. 111—Horn Switch and Horn Wire (Typical)

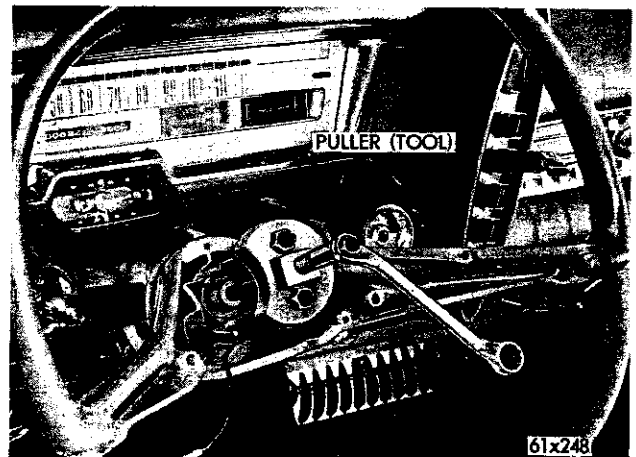

Fig. 113—Removing the Steering Wheel (Typical)

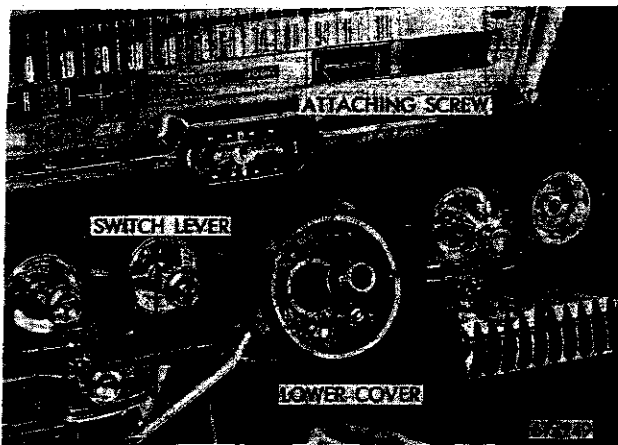

Fig. 114—Directional Switch and Lever—
Steering Wheel Removed (Typical)

the operation of the cancelling lever.

(5) Install the horn blowing switch mounting plate and the four attaching screws.

(6) Install the horn blowing switch, insulators and attaching screws. Connect the horn wire.

(7) Install the horn blowing actuator, steering wheel cover and attaching screws.

(8) Connect the battery cable at the battery negative post.

71. DIRECTIONAL INDICATOR SWITCH— CHRYSLER

Removal

(1) Disconnect the battery cable at the battery negative terminal.

(2) Compress and turn the horn button $\frac{1}{4}$ turn counterclockwise to release the button from the retainer.

(3) Disconnect the horn wire at the horn blowing switch.

(4) Remove the three (3) screws and insulators attaching the horn ring and horn blowing switch to the steering column. Remove the horn ring and

switch.

(5) Loosen the steering wheel nut several turns and install the Steering Wheel Puller **Tool C-3428** and remove the steering wheel nut and steering wheel.

(6) Remove the screw attaching the directional switch lever to the directional switch and remove the lever.

(7) Disconnect the directional switch wiring at the steering column jacket tube below the instrument panel.

NOTE: Attach a piece of string or fine wire to the directional switch wiring before removing the switch from the steering column. When the switch is removed leave the string or wire in the steering column jacket tube as an aid to replacement of the wiring.

(8) Remove the screws attaching the directional switch to the steering column and remove the switch from the top of the steering column.

Installation

(1) Attach the string or wire, that was left in the steering column jacket tube during removal, to the directional switch wiring and carefully pull the string or wire down through the column jacket tube until the directional switch wires can be connected. Position the directional switch in the steering column jacket tube and install the attaching screws and connect all wire connections.

(2) Install the directional switch lever.

(3) Install the steering wheel and the steering wheel nut, tighten to 24 foot-pounds torque. Test the operation of the cancelling lever.

(4) Install the horn blowing switch, horn ring, insulators and attaching screws. Connect the horn wire.

(5) Install the horn button by compressing and turning $\frac{1}{4}$ turn clockwise to lock the horn button on the retainer.

(6) Connect the battery cable at the battery negative terminal.

PART 7

HORNS

72. TESTING

Touch a jumper wire from relay "S" terminal to a ground. If the horn blows, the difficulty is in the horn button contact ring or in the wire from "S" terminal to the horn button. If the horn fails to blow, connect a jumper wire from "B" to "H" terminal, now if the horns operate, the relay is defective.

If the horns fail to operate, the difficulty is in the wire to the horns, in the horns or wire to horn relay "B" terminal.

AUTOLITE HORN

73. ADJUSTING

(1) Disconnect the connections at each horn to

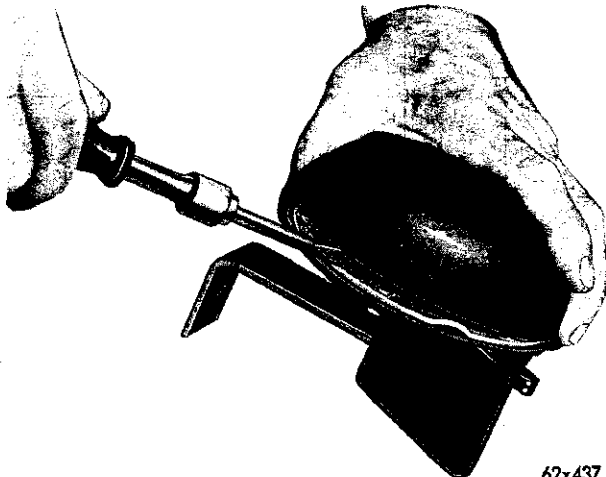

62x437

Fig. 115—Removing the Cover (Auto-Lite Horn)

determine which horn is not operating.

(2) Remove the horn and bracket assembly. Do not remove the horn from the bracket.

(3) Pry the cover off (Fig. 115).

(4) Turn the adjusting nut counter-clockwise until there is no vibration (sound).

(5) Turn the adjusting nut clockwise, approximately ¼ turn at a time until the tone has a clear mellow sound. Do not turn nut while horn is blowing.

NOTE: The adjustment will only clear up the sound and cannot change the horn tone frequency.

(6) Inspect the horn solenoid coil leads, make sure they are securely wrapped on the horn coil terminal leads (Fig. 116). If the lead wires are loose, solder them securely to the coil terminals. Use resin core solder.

(7) Check the horn contacts. If the contacts are badly burned, check the resistor for continuity. If the contacts are separated, when the adjusting nut is removed from the adjusting stud; the contacts have taken a permanent set and horn should be replaced.

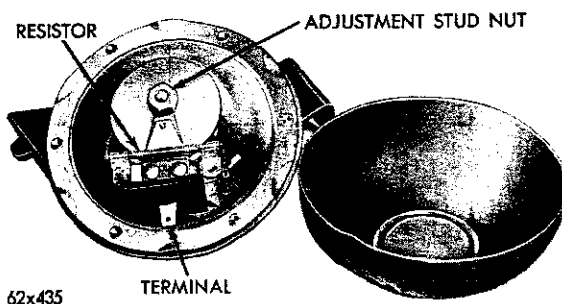

62x435

Fig. 116—Cover Removed (Auto-Lite Horn)

(8) Connect a test ammeter between the positive post of a 12 volt battery and the horn terminal post. Connect a jumper lead from the negative battery post to the horn base. Turn the adjusting screw to obtain a reading of eight amperes minimum to ten amperes maximum at 12.5 volts. **Must not exceed ten amperes maximum.**

SPARTON HORN

(1) Disconnect the connections at each horn to determine which horn is not operating.

(2) Remove the horn and bracket assembly. Do not remove the horn from the bracket.

(3) Turn the tone adjuster with a suitable spanner wrench (Fig. 117) to turning it counter-clockwise until there is no vibration (sound).

(4) Turn the tone adjuster clockwise, approximately ¼ turn at a time until the tone has a clear mellow sound. Do not turn tone adjuster while horn is blowing.

NOTE: The adjustment will only clear up the sound and cannot change the horn tone frequency.

(5) Connect a test ammeter between the positive post of a 12 volt battery and horn terminal post. Connect a jumper lead from the negative battery post to the horn base. Turn the tone adjuster obtain a reading of six amperes minimum to eight amperes maximum at 12.5 volts. **Must not exceed eight amperes maximum.**

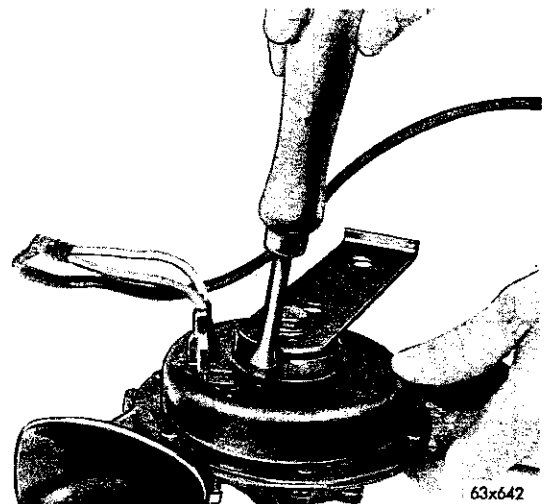

63x642

Fig. 117—Adjusting Sparton Horn

PART 7

WINDSHIELD WIPERS

The single speed wiper motor (Figure 118) is connected to the wiper switch and from the wiper switch "B" terminal to the "ACC" accessory terminal of the ignition-starter switch so that the wiper motor is actuated only when the ignition switch key is turned to the right or left position. The variable speed wiper motor is connected from the wiper motor to the wiper switch and then through a circuit breaker to the ignition switch. Refer to the "Wiring Diagrams".

The single speed wiper motor is protected by a circuit breaker built into the wiper switch. The variable speed motor is protected by a circuit breaker which is attached to the "B" terminal of the switch.

The variable speed motor (Fig. 119) has an "off-glass parking" feature which is accomplished by reversing the motor and the use of parking cams at

the pivot pins of the intermediate crank arm. When the switch is turned to the "off" position, the motor reverses direction and at the same time the parking cams rotate 180 degrees, lengthening the linkage slightly to park the blades against the windshield moulding. The linkage shortens when the motor runs in the wiping direction.

Wiper Blade Adjustment (All Models)

To properly position the wiper blades, adjust the parking switch on the motor gearbox, if necessary, so that the blades park as low as possible. Loosen the blade arms at the pivots. Position the blades against the windshield moulding on the variable speed motors and tighten the pivot attaching nuts. Position the blades of the single speed motors one inch from the windshield moulding.

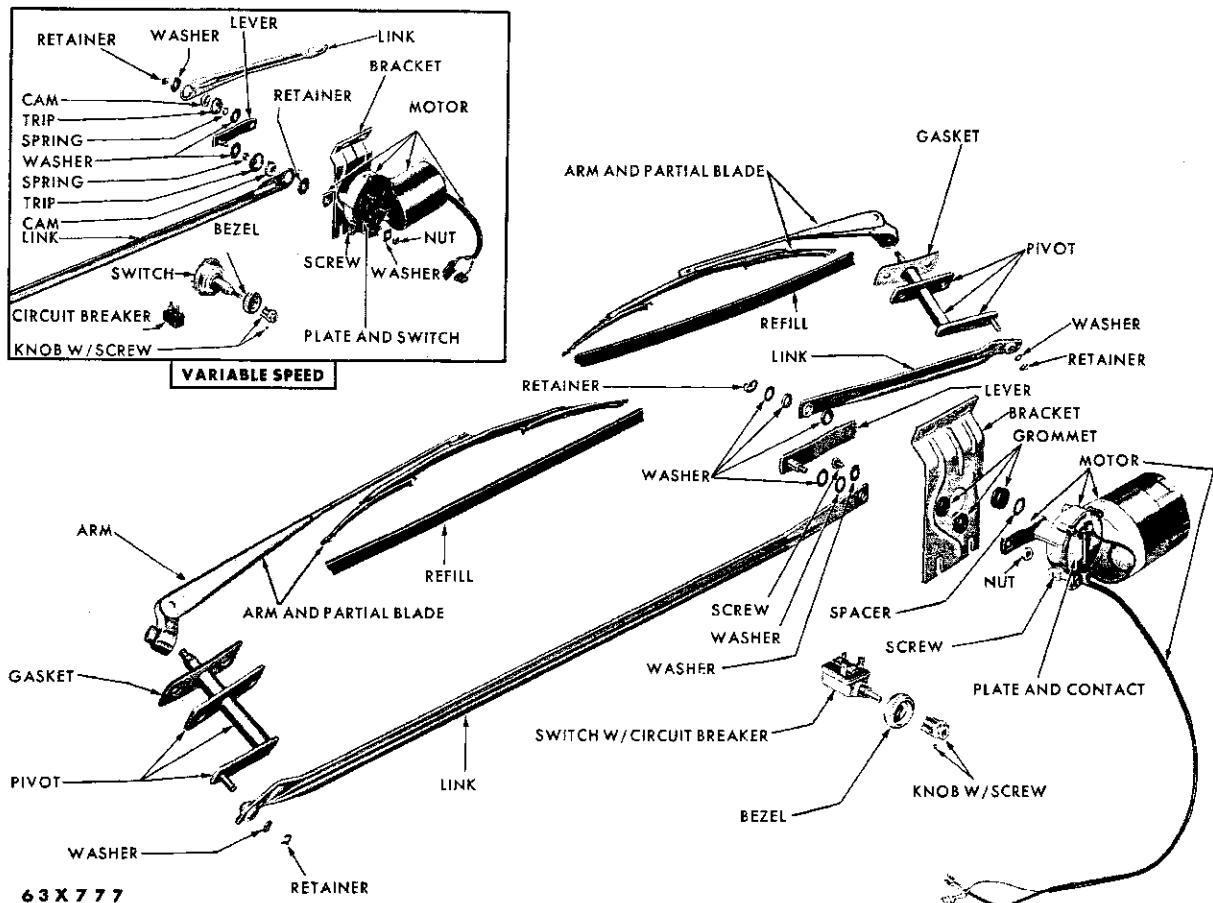

Fig. 118—Windshield Wiper Variable and Single Speed (Disassembled) Chrysler

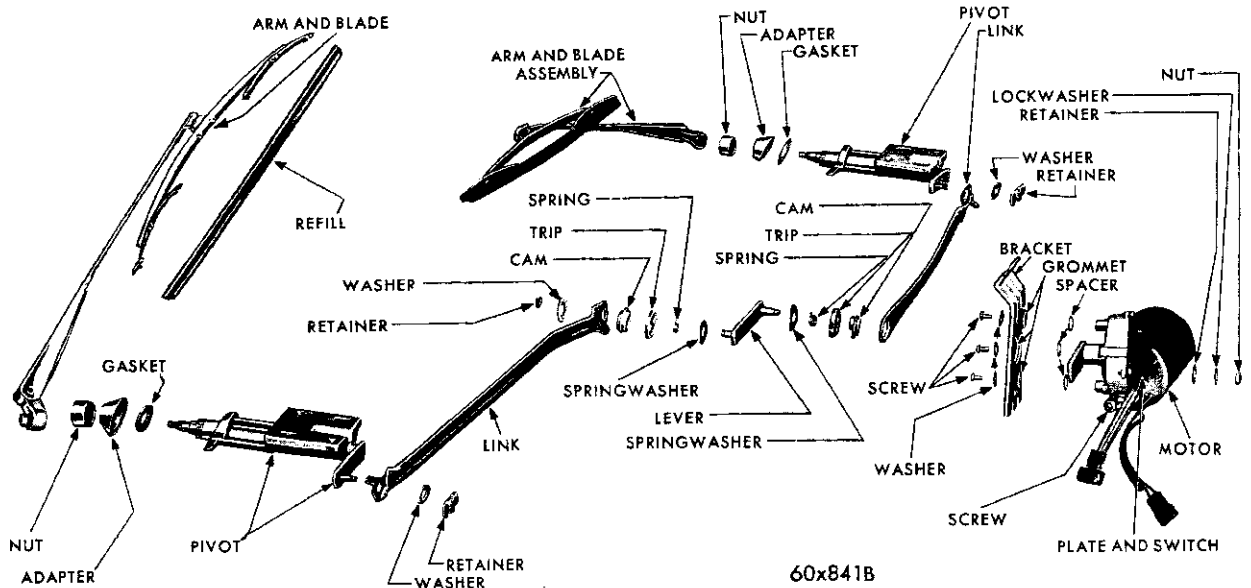

Fig. 119—Windshield Wiper Variable Speed (Disassembled) Imperial

74. WINDSHIELD WIPER MOTOR

Removal

- (1) Remove the glove compartment door.
- (2) Remove the glove compartment.
- (3) Remove the nuts attaching the wiper motor bracket to the cowl panel and to the instrument panel brace.
- (4) Disconnect the wires at the wiper motor.
- (5) Disconnect the links at the pivot cranks. The clips are removed by lifting the top tab and sliding it sideways out of engagement with the groove in the pivot crank pin.
- (6) Remove the spacing washer and remove the link from the pivot crank.
- (7) Slide the complete wiper with the links far enough towards the left so that the right hand link will clear the glove compartment opening in the instrument panel and remove assembly, as shown in Figure 120. Use care so as not to bend the links.

Installation

- (1) Enter the wiper motor, bracket and links through the glove box opening and attach the link arms to the pivot crank pins.
- (2) Install the spring washer and lock clips on the crank pins.
- (3) Install the wiper motor and bracket attaching nuts. Tighten the nuts securely.
- (4) Adjust the wiper parking position by moving the wiper motor parking switch plate.
- (5) Connect the wires at the wiper motor.

(6) Install the glove compartment and the compartment door.

75. WIPER MOTOR—(CHRYSLER TC-1, TC-2, TC-3)

Removal

- (1) Disconnect the battery cable at the battery negative terminal.
- (2) Remove the screws attaching the upper and lower mouldings to the center of the instrument panel. Slip the mouldings out from behind the passenger assist handle and remove the mouldings.
- (3) Loosen the screws attaching the heater bezel to the instrument cluster. Do not remove the bezel.

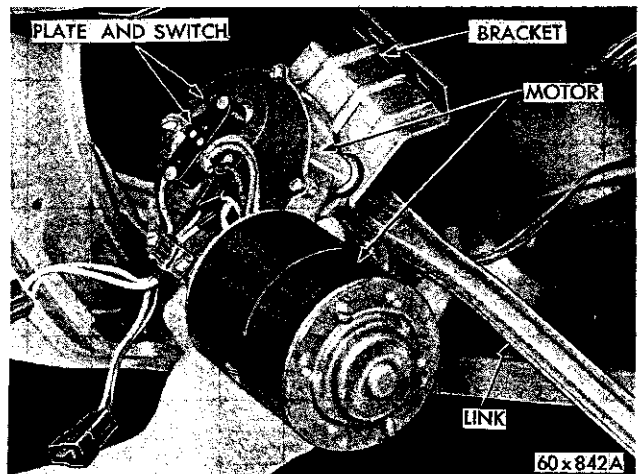

Fig. 120—Removing the Windshield Wiper Motor and Link Assembly (Typical)

(4) Remove the screws attaching the die cast speaker grille to the instrument panel and remove the grille.

(5) Remove the screws attaching the radio speaker mounting plate to the instrument panel and remove the radio speaker and mounting plate as a unit.

(6) Remove the screws attaching the glove box to the instrument panel and remove the glove box.

(7) Disconnect the wiper links at the pivots.

(8) Remove the panel support bracket from the wiper motor mounting bracket to the instrument panel lower reinforcement.

(9) Disconnect the lead wires at the wiper motor.

(10) Remove the three nuts attaching the wiper motor bracket to the cowl panel.

(11) Remove the wiper motor assembly, with both links attached, out through the glove box opening and out the right side of the vehicle.

Installation

(1) Install the wiper motor and bracket assembly, with both links attached through the glove box opening from the right side of the vehicle. Position the motor mounting bracket on the studs on the cowl panel and install the mounting nuts.

(2) Connect the lead wires to the wiper motor.

(3) Install the panel support bracket from the wiper motor mounting bracket to the instrument panel lower reinforcement.

(4) Install the wiper links to the wiper pivots.

(5) Install the glove box in the instrument panel opening and install the attaching screws.

(6) Install the radio speaker and mounting plate in the instrument panel opening and install the attaching screws.

(7) Position the radio speaker die cast grille in the instrument panel and install the attaching screws.

(8) Tighten the heater bezel attaching screws.

(9) Position the instrument panel center upper and lower mouldings under the passenger assist handle and install the attaching screws.

(10) Connect the battery cable at the battery negative terminal.

(11) Check operation of the wipers.

76. MOTOR LINKS

Disassembly

(1) Remove the clip holding the left-hand link to the crank arm.

(2) Remove the bevel washers and the link.

(3) Remove the parking cam and the spring release. (Variable speed).

(4) Remove the coil spring by spreading the ends of the spring. (Variable speed).

(5) Disassemble the right-hand link in the same manner after removing the crankarm to lever nut and the spacing washers between the link crank arm and lever.

77. WIPER MOTOR

Single Speed Motor (If so Equipped)

Disassembly

Before disassembling the wiper motor note the relationship between the parking switch, cam, and crank arms.

(1) Remove the switch plate first.

(2) Remove the motor crank nut, washers and motor crank arm.

(3) Lift out the nylon gear, noting position of the gear.

(4) Remove the end head through bolts and carefully pull off the end head. The armature can then be removed.

Variable Speed Motor (Disassembly)

(1) Remove the switch plate and the cover screws.

(2) Remove the crank arm nut, washers, crank arm, and gear in that order.

(3) Remove the end head through bolts and pull out the end head using care so as not to break the lead wire to the brush holder.

(4) Remove the armature.

Motor Inspection

(1) Thoroughly inspect the motor parts for wear, corrosion or damage.

(2) Clean the armature commutator with 00 or 000 sandpaper or if necessary, turn down the commutator.

(3) Replace worn or oil soaked brushes.

(4) Check the armature and crankshaft in their respective bushings and replace worn parts if any looseness is detected.

(5) Inspect the gears for worn or broken teeth and replace those showing damage or excessive wear.

Replacing Commutator

If the armature commutator is rough or out of round, burned or the bakelite material is even with or extends above the surface of the commutator bars, the commutator should be turned down. Remove only enough metal to provide a clean smooth surface. Operation can be performed on a suitable lathe or by using Tool C-770, as shown in Fig. 121.

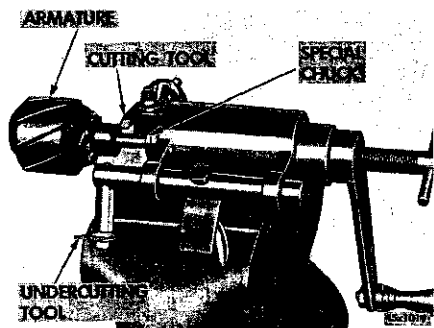

Fig. 121—Refacing the Commutator

Undercutting Bakelite

Undercut the bakelite segments to a depth of $\frac{1}{16}$ inch, using Tool C-770 with special blade SP-839, as shown in Figure 122. Be sure to undercut the bakelite squarely. After undercutting, polish the commutator with 00 or 000 sandpaper to remove burred edges.

CAUTION: Be sure the commutator is clean and free from oil or grease. A dirty, greasy commutator will cause a high resistance and greatly impair the efficiency of the wiper.

78. WINDSHIELD WIPER SWITCH

Single Speed Motor (If so Equipped)

The switch contains a built-in circuit breaker to protect the motor and is serviced only as an assembly. To test the switch, refer to the proper wiring diagram at the back of the "Electrical Group," disconnect the lead wires and remove the switch from the instrument panel. Connect a test lamp between the "B" terminal of the switch and the negative battery post. Connect a jumper wire from the positive battery terminal to the "P" terminal of the switch. The lamp should remain lighted when the switch is in the "off" or "on" position. Failure to light indicates faulty circuit breaker.

Connect the positive battery terminal jumper lead to the "R" terminal of the switch. The lamp should

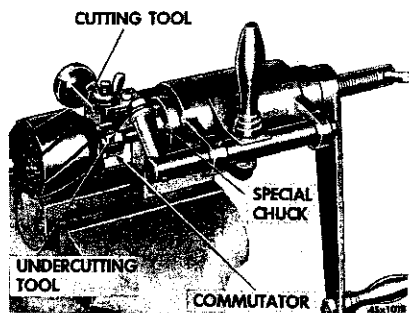

Fig. 122—Undercutting the Bakelite

light when the switch is turned "on" and go out when the switch is turned "off".

Variable Speed Motor

The switch contains a bar resistance plate which provides a means of controlling the amount of current flow to the motor field as the switch control shaft is rotated. In addition, the switch is designed to provide a circuit to the motor to reverse the direction of the current to the field winding thus providing a means of reversing the armature. A separate circuit breaker is attached to the "B" terminal of the switch to protect the motor.

To test the switch, refer to the proper wiring diagram at the back of the "Electrical Group," disconnect the lead wires and remove the switch. Connect a jumper wire from the battery positive terminal to the case of the switch and another jumper wire from the battery positive terminal to the "FT" terminal of the switch. Connect a test lamp between the battery negative terminal and the "B" terminal of the switch. Lamp should light when switch is turned on and gradually dim, as switch is turned clockwise. Lamp should go "out" when the switch is turned "off". The switch is serviced only as an assembly.

79. END PLAY ADJUSTMENT

To adjust the armature shaft end play turn the adjustment screw in until it bottoms and back off $\frac{1}{4}$ turn (Fig. 123).

80. WIPER MOTOR BENCH TESTING

Single Speed Motor

(1) Connect a jumper wire between the battery negative terminal and the wiper motor ground strap. Connect another jumper wire between the black and blue wires of the wiper motor and the battery positive terminal. The motor should run continuously.

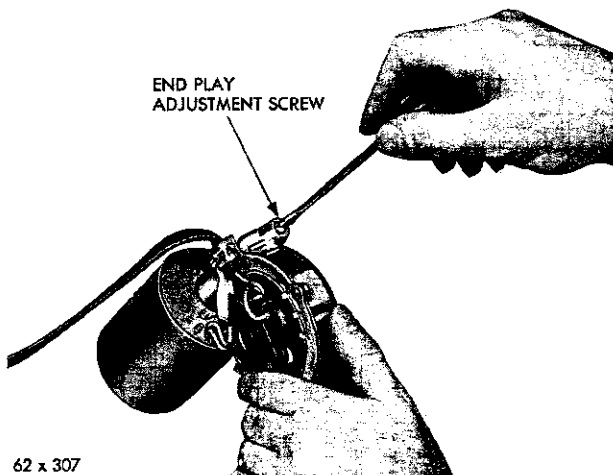

62 x 307

Fig. 123—End Play Adjustment

(2) With the jumper wires connected, as in Step 1, disconnect the black wire from the jumper wire leaving the blue wire connected to the battery positive terminal. The wiper motor should park.

Variable Speed Motor

(1) Connect a jumper wire between the wiper motor yellow wire and the wiper motor ground strap. Connect another jumper wire between the battery negative terminal and the wiper motor ground strap. Connect another jumper wire between the wiper motor red and black wires and the battery positive terminal. The wiper motor should run continuously in the wipe direction.

(2) Connect a jumper wire between the wiper motor blue and yellow wires and the battery positive terminal. Connect another jumper wire between the wiper motor red wire and the wiper motor ground strap. Connect another jumper wire between the battery negative terminal and the wiper motor ground strap. Momentarily touch the wiper motor black wire to the wiper motor yellow and blue wires. The wiper motor should park.

Assembly of Wiper Motor

Make sure the gear teeth are adequately covered with long fibre grease.

The correct indexing of the contact plate (single speed motor) or the contact follower (variable speed motor) on the nylon gear is important. After the

armature, nylon gear, and crank arm are installed, index the contact plate (constant speed motor) on the nylon gear with the slot pointing in the same direction as the motor crank arm. Install the contact follower (variable speed motor) with open end pointing in the same direction as the motor crank arm.

Assembly of Wiper Link—Variable Speed

Install the spring washer, concave surface toward the crank arm. Install the crank pivot coil spring on the pivot. Install the spring release.

Install the parking cam to index with the spring release and engage the spring ends, between the release and parking cam in the openings at point of index (Fig. 124).

If the intermediate crank is held so that the letter "L" is visible, install the cam release so that the letter "L" can be seen from that position. The opposite side will show three letters "R".

Install the spring washer, convex surface toward the cam assembly. Install the link arm with the stop projection on the link arm toward the cam assembly. Install the retaining bolts and nut (Fig. 125). Assemble the left link and cam assembly in the same manner locking in place with a clip.

81. REPLACING WIPER PIVOT

Remove the wiper arm. Disconnect the link from the pivot. Remove the pivot retaining plate pivot and gasket.

Install a new gasket and pivot.

Tighten the retaining nuts securely. Re-install wiper link. Install the wiper arm and blade.

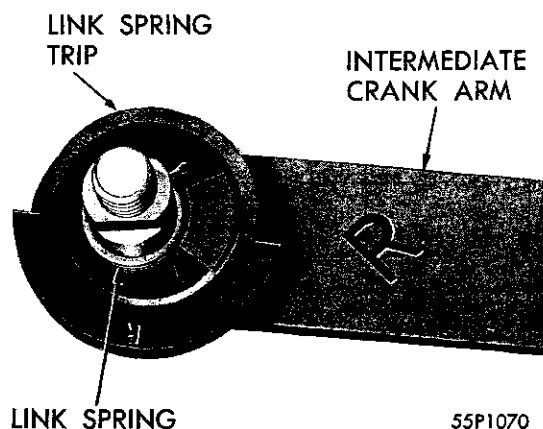

Fig. 124—Link Spring Trip Installed (Variable Speed)

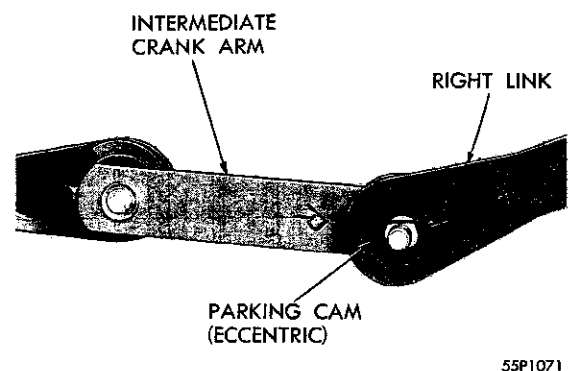

Fig. 125—Link Arm Installed (Variable Speed)

PART 8

POWER SEATS

The power seat can be moved six ways — forward, backward, upward, downward and tilt. The horizontal

travel is five inches and horizontal plane of seat track is inclined eleven degrees. The vertical travel is one

inch at front and two inches at rear. The available tilt is 8 degrees forward and 7½ degrees rearward from neutral.

Operation

The motor operates a gear drive train which supplies power to the slave units, located in the seat tracks, through flexible cables (Fig. 126). The control switch is on the left side of front seat and is wired through a relay to a 30 ampere circuit breaker, located above the left cowl panel.

The wire from the bulkhead disconnect supplies power to the circuit breaker. Power is supplied to the relay from the circuit breaker.

Six wires go to the switch. One used for power, two for motor field current, which also actuates the relay for motor armature current and three wires attach to solenoids controlling the movement of the front riser, rear riser and horizontal movement.

The right and left tracks are each replaced as an assembly only. They cannot be adjusted and are not interchangeable.

82. FRONT SEAT ASSEMBLY AND ADJUSTER

Removal

- (1) Disconnect the battery ground cable.
- (2) Remove the four mounting stud nuts which hold the front seat to the adjuster and tilt the complete seat back assembly forward.
- (3) Disconnect the switch control wires.
- (4) Remove the front seat and cushion assembly.
- (5) Disconnect the seat adjuster red feed wire.
- (6) Remove the seat guide attaching stud nuts and remove the adjuster. On Imperial remove the nut which holds the strut to the floor pan bracket before removing the adjuster.

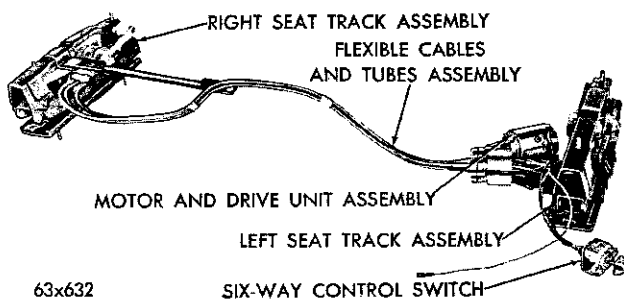

Fig. 126—Power Seat Arrangement

Installation

- (1) Install the adjuster and seat guide stud nuts.
- (2) Reconnect the seat adjuster red feed wire.
- (3) Install the front seat and cushion assembly.
- (4) Reconnect the control wires to the switch and tighten the mounting stud nuts securely.
- (5) Reconnect the battery ground cable.

83. FLEXIBLE CABLES

Removal

- (1) Remove the front seat and cushion assembly.
- (2) Disconnect the red fed wire.
- (3) Remove the retainer plate that holds the right side tubes to the drive assembly.
- (4) Remove the left seat guide attaching stud nuts and remove the guide and the drive assembly (Fig. 127).

NOTE: Be careful not to bend or damage tubes when sliding out the drive assembly.

- (5) Remove the bracket screws at the right slave unit remove the tubes and flexible cables assembly (Fig. 128).
- (6) Remove the bolts that hold the motor and drive assembly to the left guide bracket.
- (7) Remove the drive assembly with tubes from the left slave unit (Fig. 129).
- (8) Remove the flexible cables from the tubes.

Installation

CAUTION: The seat guides should be in the up and forward position when installing the cable. Make sure both guides are at the same position (in alignment).

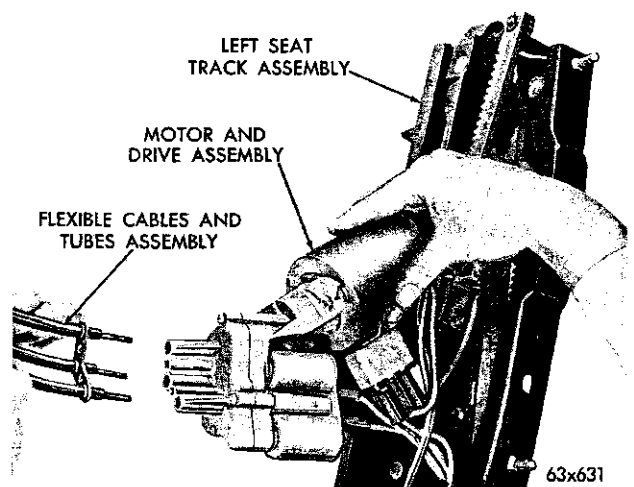

Fig. 127—Removing Cables from Drive

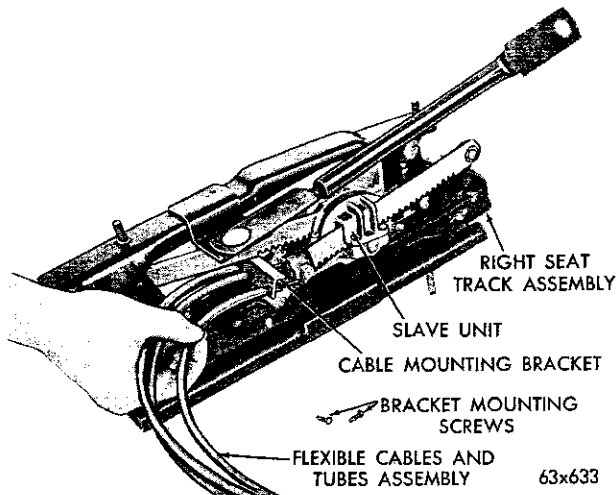

Fig. 128—Removing Cables from Right Slave Unit

(1) Place the three left cable tubes into the left slave unit (Fig. 130).

(2) With the shortest tube on the inside and longest on the outside, install the flexible cables in the tubes. Make sure the cables seat in the slave unit.

(3) Position the drive unit on the left side tubes. Make sure the flexible cables seat in the slot in the drive unit.

(4) Bolt the drive unit to the guide bracket.

(5) Place the right side flexible cables in the right side tubes.

(6) Position the left guide and drive assembly on

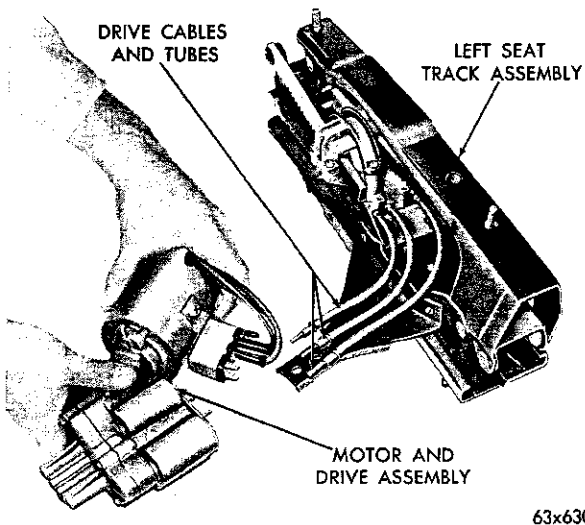

Fig. 129—Removing Drive Assembly from Left Slave Unit (Typical)

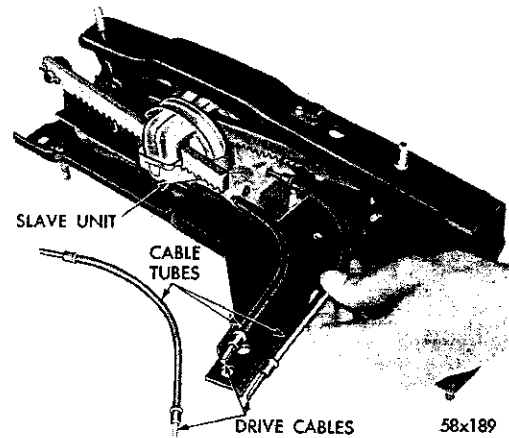

Fig. 130—Installing Left Cable Tubes in Slave Unit

the right side tubes. Make sure the cables seat in the drive assembly.

(7) Install the right side tubes retainer plate.

(8) Bolt the left guide assembly to the floor.

(9) Install the seat and cushion assembly.

(10) Reconnect the red feed wire and check the operation of the seat.

84. MOTOR ASSEMBLY

Removal

(1) Disconnect the motor wires at the relay.

(2) Remove the two nuts holding the motor to the drive unit.

(3) Remove the motor from the drive unit and rubber coupling.

(4) Remove the relay from the motor.

Installation

(1) Install the relay on the motor.

(2) Install the rubber coupling on the motor shaft (Fig. 131).

(3) Align the rubber coupling with the slot on the slave unit shaft.

(4) Install the motor and reconnect the wires to the relay.

85. DRIVE UNIT AND SOLENOID ASSEMBLY

Disassembly

(1) Remove the drive unit from the seat assembly. Refer to "Removal of the Flexible Cables". Steps 1-4

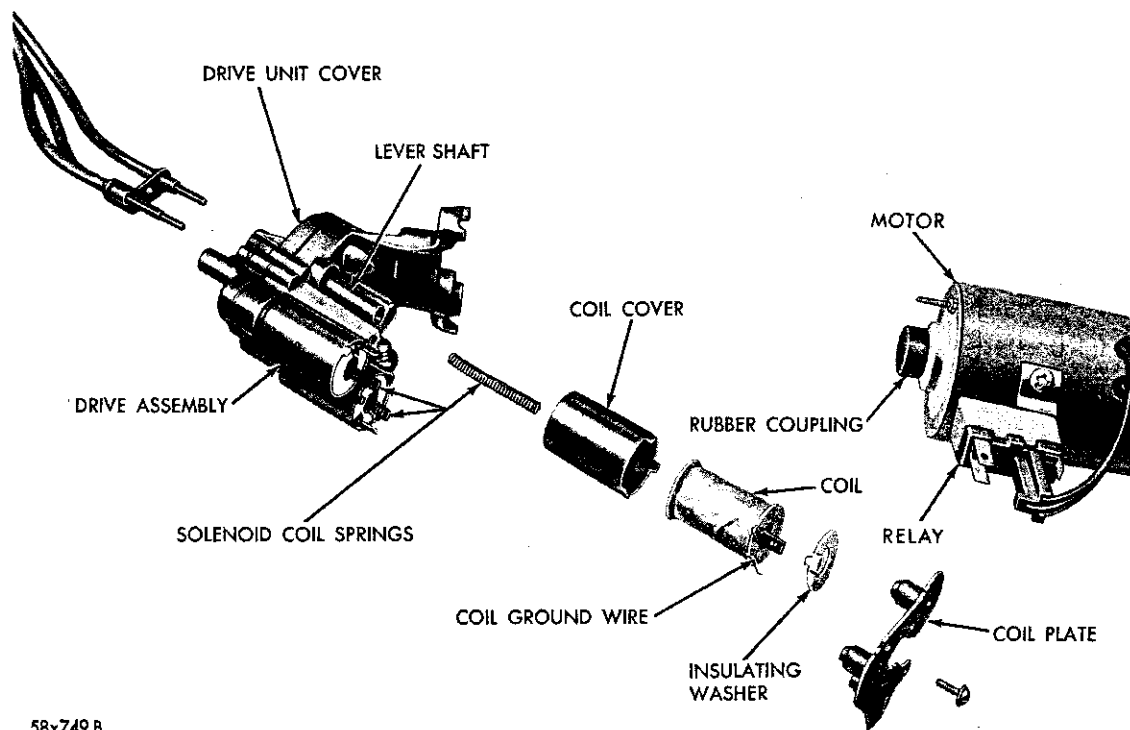

58x749 B

Fig. 131—Solenoid and Coil (Disassembled View)

(2) Remove the two screws holding the plate and solenoids to the drive unit.

(3) Remove the plate and solenoid assembly. Be careful not to lose the three springs under the solenoid.

(4) To remove the solenoid coils, bend back on the tabs of the solenoid cover. Unsolder the coil ground wire at the cover tab and remove the coil cover from the coil.

(5) Remove the screws holding the cover on the drive unit.

(6) Remove the cover and lift out the clutch lever and shaft.

Assembly

(1) Install the clutch lever and shaft. Make sure the lever is properly seated on the drive collar.

(2) Install the cover and screws.

(3) Install the coil in the coil cover with the coil ground wire next to one of the cover tabs.

(4) Position the cover tabs in the slots on the coil plate.

(5) Bend over the tabs and resolder the coil ground wire to the tab and plate.

(6) Install the three solenoid springs and position the solenoids over the springs.

(7) Fasten the solenoids to the drive unit.

(8) Install the drive unit. Refer to "Installation of Flexible Cables". Steps 6-9.

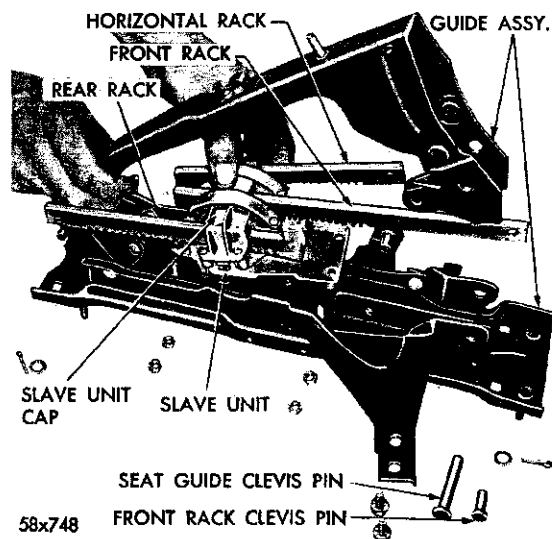

58x748

Fig. 132—Removing and Installing the Left Slave Unit

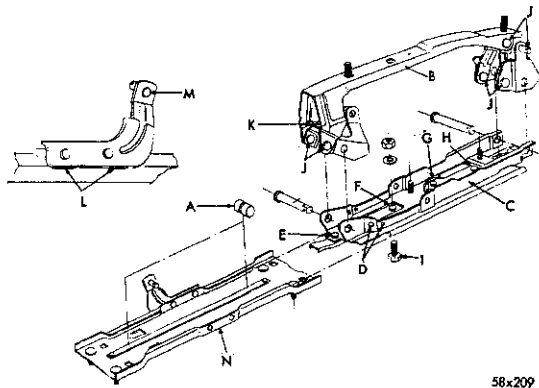

Fig. 133—Seat Guide (Exploded View)

86. SLAVE UNIT

Removal (Fig. 132)

(1) Remove the drive unit and the cables. Refer to "Removal of Flexible Cables". Steps 1-4. The seat guide should be in the up and forward position.

(2) Remove the long clevis pin from the front of the guide.

(3) Remove the front rack clevis pin.

(4) To facilitate the removal of the slave unit, remove the slave unit cap.

NOTE: Be careful not to lose the springs under the cap. The springs are between the racks and the slave cap.

(5) Remove the nuts holding the slave unit to the guide.

(6) Remove the slave unit.

Installation

(1) Position the slave unit over the studs on the guide base.

(2) Position the racks in the slave unit so they will be in the up and forward position.

(3) Fasten the racks to the guide assembly.

(4) Position the springs on the racks and install the slave unit cap.

(5) Install the slave unit mounting nuts.

(6) Install the front guide clevis pin.

(7) Install the cables in their slots and try operation of guide.

Install drive unit and cables. Refer to "Installation of Flexible Cables". Steps 6-9.

87. SEAT ADJUSTMENT (Refer to Fig. 133)

(1) Remove the power seat assembly from the vehicle.

(2) Remove the seat drive tubes from the slave unit.

CAUTION: Do not run the seat motor with the drive cables and tubes disassembled or the unit will be placed out of synchronization.

(3) Remove the seat support (B).

(4) Remove the seat slave unit from the seat track slide (C).

(5) Remove the horizontal stops located on the slide at (D).

(6) Separate the seat slide (C) from the base (N) by pressing the slide rearward which will allow the rollers (A) to jump the retaining rivets (E, F, G, H), thereby separating the slide from the base.

(7) Remove the rivet (F) and replace with $\frac{5}{16}$ - 18 x $\frac{1}{2}$ " cap screw (I) as shown to retain in the proper position. To reassemble, reverse the above sequence.

NOTE: In reassembly, frayed drive cable may occur. Such a cable may be repaired by applying a light coating of solder and then grinding to cable size.

88. MOTOR AND RELAY TEST

Connect a test light to the red wire at the motor relay. If the test light does not light, check for continuity in the number 10 red feed wire, a faulty circuit breaker or a poor connection between the circuit breaker and bulkhead disconnect. If the test light lights, connect number 10 red feed wire with the red and black or red and green wires from the motor. If the motor runs, the relay was faulty.

89. WIRING TESTS

Disconnect the 6-way terminal connector that connects the switch to the seat actuator. Using jumper wires, connect the jumpers, as shown in the following test chart for the six various control operations. If the operation is normal, by connecting the wires, as shown in the chart, replace the switch.

POWER SEAT ELECTRICAL TEST CHART

For Forward Horizontal	For Forward Tilt	For Straight Up
Red Connect—Blue Green	Red Connect—Blue Yellow	Red Connect—Blue Yellow Brown
For Rearward Horizontal	For Rearward Tilt	For Straight Down
Red Connect—White Green	Red Connect—Blue Brown	Red Connect—White Yellow Brown

PART 8—ELECTRICAL WINDOW LIFTS

A master switch group, on the left front door, operates all the windows and the individual switches are located on their respective doors. The circuit breakers are above the left front cowl panel.

90. WINDOW LIFTS

Removal

(1) Disconnect the battery cable at the battery negative terminal.

(2) Remove the garnish molding, the door trim panel and disconnect the wires from the switch.

(3) Remove the clips from the regulator pins holding the lower glass channel.

(4) Raise the glass manually and prop in the up position.

(5) Remove the regulator attaching screws, pivot the guide retaining pin and remove the motor and regulator through the opening in the door.

(6) If it is necessary to replace the gear box, remove the regulator counter-balance spring.

NOTE: Be sure to remove the counter-balance spring before disassembling the gear box.

The gear box is replaced as an assembly only and is lubricated at assembly. No further lubrication is required.

Installation

(1) Place the motor and regulator through the door opening and insert the pivot arm pin into the guide on the inner panel.

(2) Install the regulator screws finger tight. **DO NOT** tighten at this time.

(3) Remove the window prop and lower the glass.

(4) Insert the control arms into the glass channel, using a leather washer on each side of the channel and secure with a clip.

(5) Connect the wires to the motor and connect the battery.

(6) Operate the window several times and stop the glass halfway.

(7) Tighten the regulator screws.

(8) Check the glass alignment.

(9) Connect a test ammeter into the electrical circuit and operate the window. The ammeter reading should be constant without fluctuation as follows: approximately 14 amperes, all models except rear doors of four-door hard top models, and approximately 20 amperes for the rear doors of the four-door hard top models.

If the ammeter reading fluctuates, there is a bind in the glass or in the linkage. The down stop should be adjusted so that the window is flush with the garnish moulding.

(10) Install the trim panel, switch and garnish moulding.

91. WIRING TEST

Disconnect the cable at the battery negative post and remove the two window lift feed wires from the circuit breaker. **Do not** remove the battery feed wire. Reconnect the battery negative cable at battery and replace the feed wires one at a time as follows:

(1) One feed wire feeds the left front door.

(2) The other feed wire feeds the right front door and both rear doors.

(3) Test the wiring to the doors one at a time to locate the short.

NOTE: When testing for faulty wiring, inspect the wiring harness control wires for a break behind the plate and sector or the regulator in each door.

PART 8

ELECTRIC LOCKING DOOR LOCKS—IMPERIAL TY-1

The electric door lock is operated by a push-pull double action solenoid attached by a connecting rod to the door latch locking lever. By pressing the single pole double throw switch mounted on the right and left front door trim panel, a solenoid in each of the four doors is actuated, moving the latch locking lever into the lock or unlock position.

All doors may be locked or unlocked either mechanically or electrically. To lock mechanically push the front door handle to the forward position and depress the rear door locking button. To lock electrically depress the switch to lock or lift upward to unlock the doors.

92. SOLENOID

Removal

Remove the door trim panel. Disconnect the lock to solenoid connecting rod at the solenoid. Disconnect wires and remove solenoid.

Installation

Fasten the solenoid to the door and connect up the wires. Tighten the solenoid mounting screws finger tight. Reconnect the lock connecting the rod to the solenoid. Adjust the solenoid by moving up or down in the slotted holes, so that the solenoid will push and pull the lever far enough to accomplish locking and unlocking. Reinstall the trim panel.

CIRCUITS		
CIR	GA	COLOR
W-1	12	TAN
W-2	14	YELLOW
W-2A	12	YELLOW
W-3	14	BLACK
W-4	14	WHITE
W-11	14	DARK BLUE
W-11A	14	BLACK
W-12	14	PINK
W-12A	14	PINK
W-13	14	ORANGE
W-13A	14	ORANGE
W-13B	14	ORANGE
W-14	14	GRAY
W-14A	14	GRAY
W-21	14	BROWN
W-21A	14	LIGHT GREEN
W-22	14	VIOLET
W-22A	14	VIOLET
W-22B	14	VIOLET
W-23	14	RED
W-23A	14	RED
W-23B	14	RED
W-24	14	DARK GREEN
W-24A	14	DARK GREEN
W-24B	14	DARK GREEN

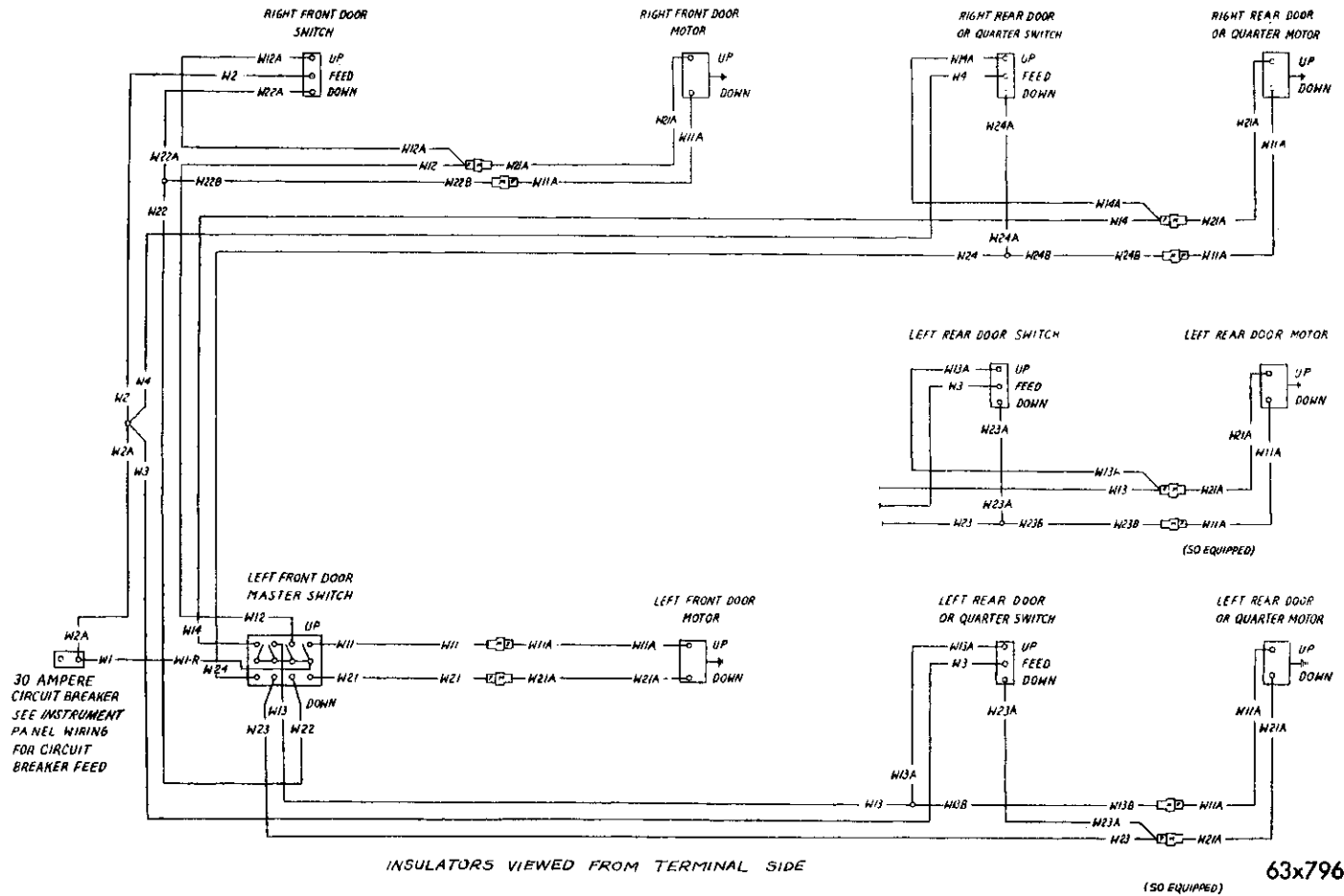
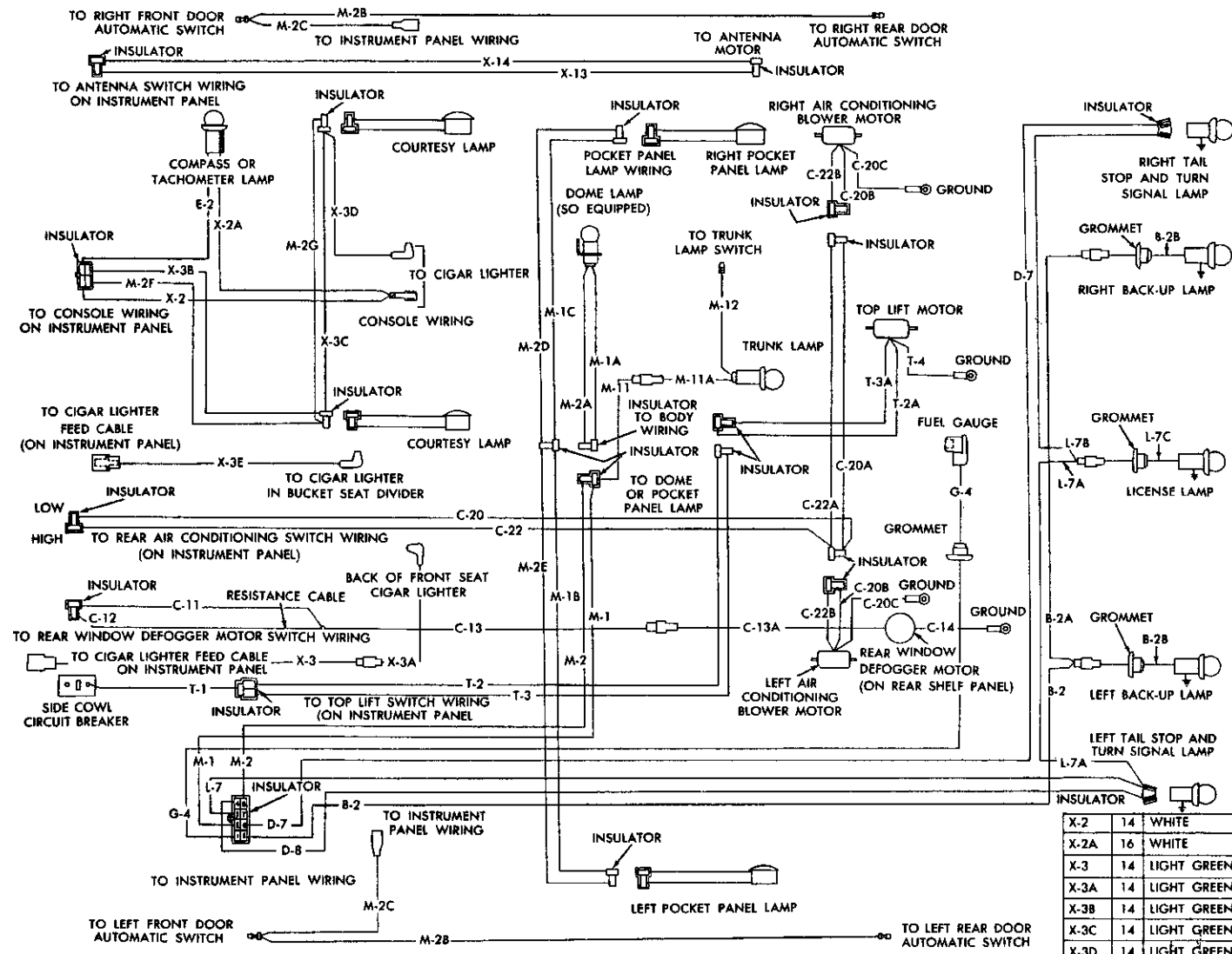

Fig. 134—Electric Window Lift (Chrysler)



CIRCUITS		
CIR.	GR.	COLOR
B-2	18	WHITE
B-2A	18	WHITE
B-2B	18	WHITE
C-11	18	BLACK
C-12	20	WHITE
C-13	18	BLACK
C-13A	14	BLACK
C-14	14	BLACK
C-20	16	BROWN
C-20A	16	BROWN
C-20B	16	BROWN
C-20C	16	BLACK
C-22	16	DARK GREEN
C-22A	16	DARK GREEN
C-22B	16	DARK GREEN
D-7	18	BROWN
D-8	18	DARK GREEN
E-2	18	ORANGE
G-4	18	LIGHT BLUE
L-7	18	BLACK
L-7A	18	BLACK
L-7B	18	BLACK
L-7C	18	BLACK
M-1	18	PINK
M-1A	18	PINK
M-1B	18	PINK
M-1C	18	PINK
M-2	18	YELLOW
M-2A	18	YELLOW
M-2B	18	YELLOW
M-2C	18	YELLOW
M-2D	18	YELLOW
M-2E	18	YELLOW
M-2F	18	YELLOW
M-2G	18	YELLOW
M-11	18	PINK
M-11A	18	PINK
M-12	18	YELLOW
T-1	12	RED
T-2	12	BROWN
T-2A	12	RED
T-3	12	YELLOW
T-3A	12	YELLOW
T-4	12	BLACK
X-2	14	WHITE
X-2A	16	WHITE
X-3	14	LIGHT GREEN
X-3A	14	LIGHT GREEN
X-3B	14	LIGHT GREEN
X-3C	14	LIGHT GREEN
X-3D	14	LIGHT GREEN
X-3E	14	LIGHT GREEN
X-13	18	BROWN
X-14	18	YELLOW

63 x 794

INSULATORS VIEWED FROM TERMINAL SIDE

Fig. 135—Body and Dome Lamp (Except Town and Country) (Chrysler)

CIRCUITS		
CIR	GA	COLOR
B-2	18	WHITE
B-2A	18	WHITE
B-2B	18	WHITE
B-2C	18	WHITE
C-20	16	BROWN
C-20A	14	BROWN
C-20B	14	BROWN
C-20C	14	BROWN
C-20D	14	BROWN
C-22	16	DARK GREEN
C-22A	14	DARK GREEN
C-22B	14	DARK GREEN
C-22C	14	DARK GREEN
C-22D	14	DARK GREEN
C-24	14	BLACK
C-24A	14	BLACK
C-24B	14	BLACK
C-24C	14	BLACK
D-7	18	BROWN
D-7A	18	BROWN
D-8	18	DARK GREEN
G-4	18	LIGHT BLUE
L-7	18	BLACK
L-7A	18	BLACK
L-7B	18	BLACK
L-7C	18	BLACK
L-7D	18	BLACK
L-7E	18	BLACK
M-1	18	PINK
M-1A	18	PINK
M-1B	18	PINK
M-1C	18	PINK
M-2	18	YELLOW
M-2A	18	YELLOW
M-2B	18	YELLOW
M-2C	18	YELLOW
M-2D	18	YELLOW
M-3	18	BROWN
W-5	12	RED
W-5B	12	RED
W-5C	12	RED
W-5D	12	RED
W-5E	12	RED
W-5F	12	RED
W-5G	12	RED
W-5H	12	RED
W-5K	12	RED

CIRCUITS		
CIR	GA	COLOR
W-15	12	BROWN
W-15A	12	BROWN
W-15B	12	BROWN
W-15C	12	BROWN
W-15D	12	BROWN
W-15E	12	BROWN
W-15F	12	BROWN
W-15G	12	BROWN
W-15H	14	DARK GREEN
W-15J	12	BROWN
W-25	12	YELLOW
W-25A	12	YELLOW
W-25B	12	YELLOW
W-25C	12	YELLOW
W-25D	12	YELLOW
W-25E	12	YELLOW
W-25F	12	YELLOW
W-25G	14	BLACK
W-25H	12	YELLOW
X-3	14	LIGHT GREEN

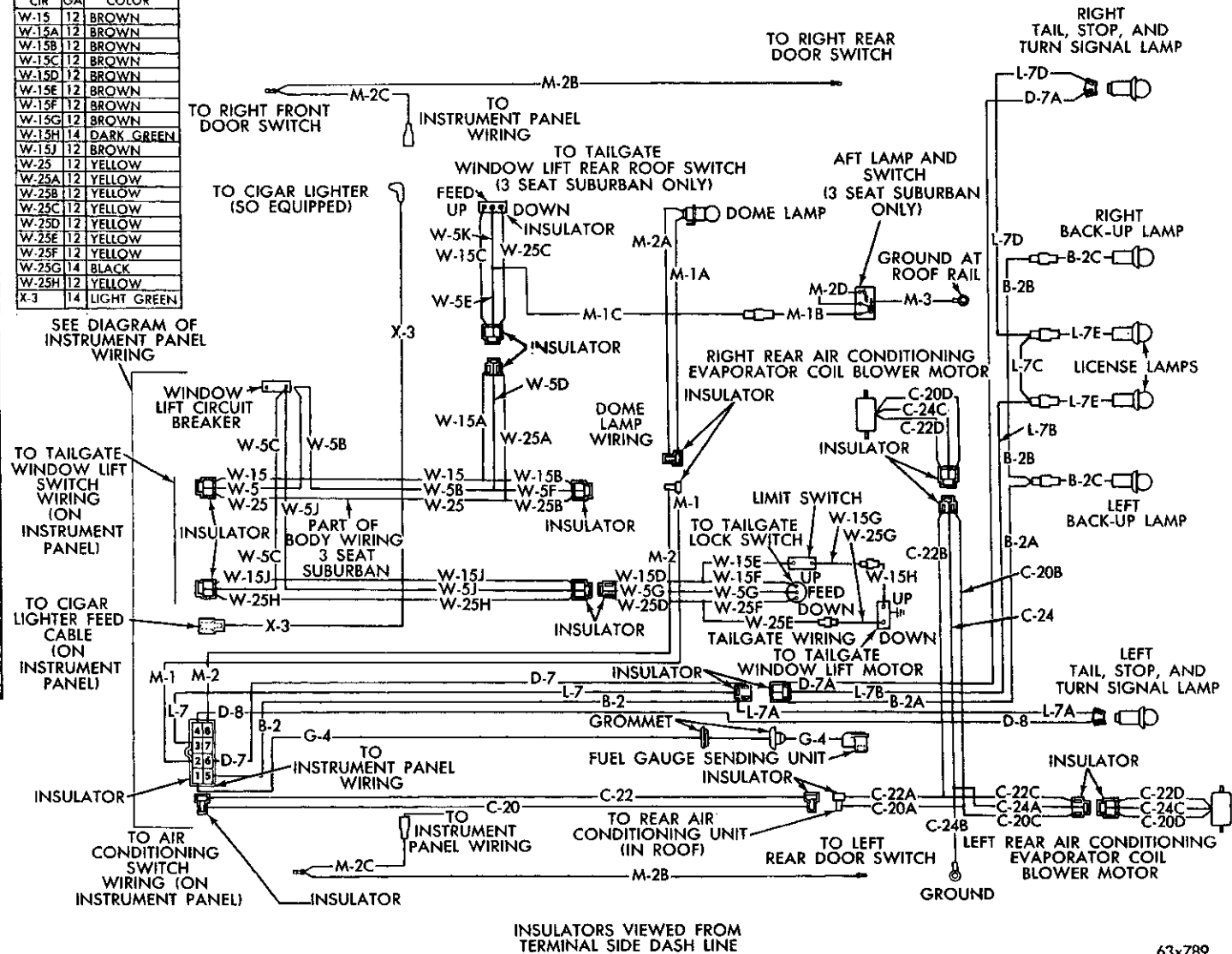

Fig. 136—Body and Dome Lamp (Town and Country) (Chrysler)

63x789

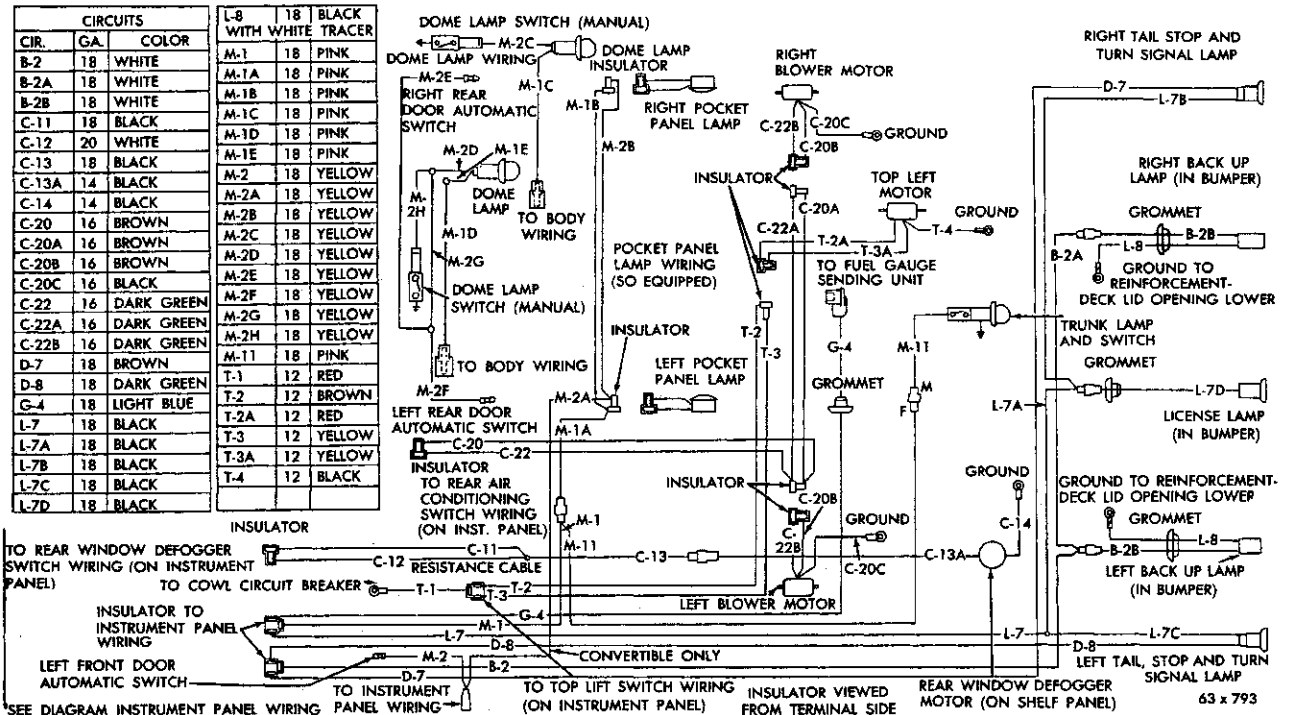

Fig. 137—Body and Dome Lamp (Imperial)

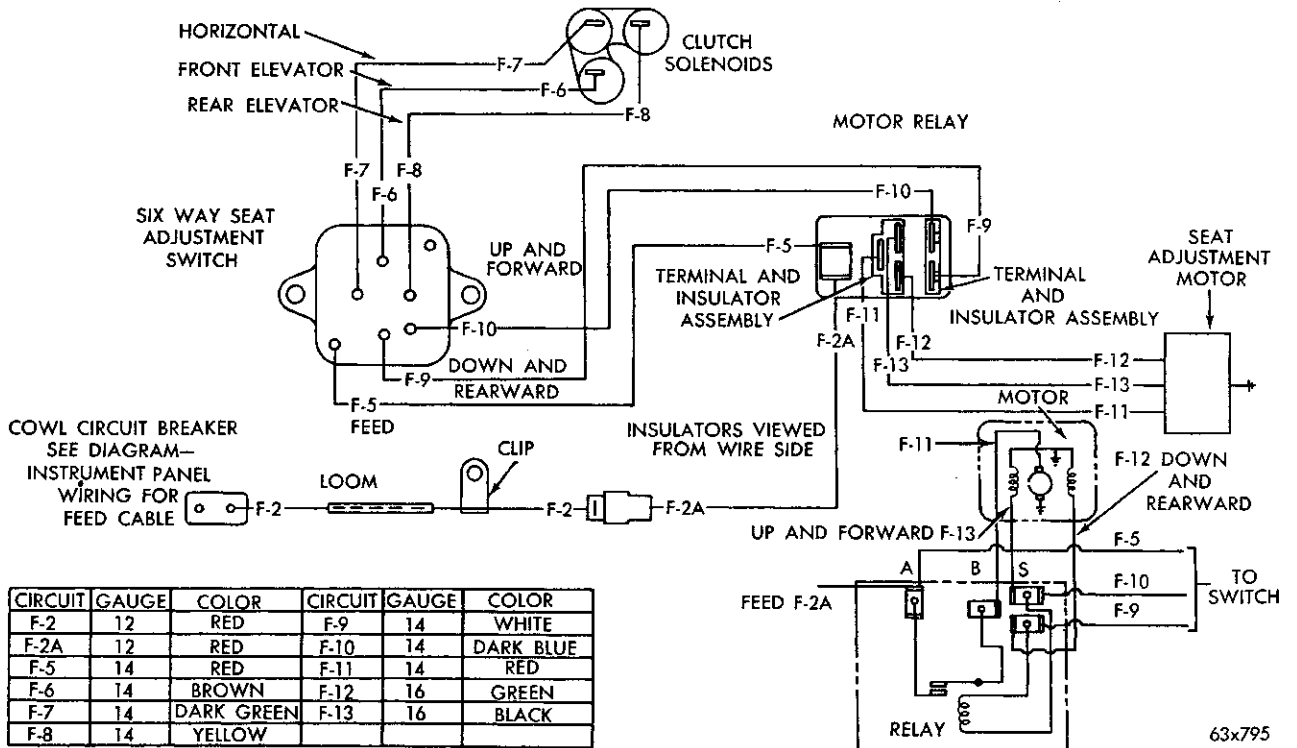

Fig. 138—Six Way Seat Adjusting

CIRCUITS		
CIR.	GA.	COLOR
M-1	18	PINK
M-1A	18	PINK
M-1B	18	PINK
M-2	18	YELLOW
M-2A	18	YELLOW
M-2B	18	YELLOW
M-2C	18	YELLOW
M-2D	18	YELLOW
M-2E	18	YELLOW
M-2F	18	YELLOW
M-2G	18	YELLOW
M-2H	18	YELLOW
W-1	12	TAN
W-1A	12	TAN
W-1B	14	TAN
W-2	12	YELLOW
W-2A	14	YELLOW
W-2B	12	YELLOW
W-3	14	BLACK
W-4	14	WHITE
W-11	14	DARK BLUE
W-11A	14	BLACK
W-12	14	PINK
W-12A	14	PINK
W-13	14	ORANGE
W-13A	14	ORANGE
W-14	12	GRAY
W-14A	14	GRAY
W-14B	12	GRAY
W-21	14	BROWN
W-21A	14	GREEN
W-22	12	VIOLET
W-22A	14	VIOLET
W-22B	14	VIOLET
W-23	14	RED
W-23A	14	RED
W-23B	14	RED
W-24	12	DARK GREEN
W-24A	14	DARK GREEN
W-24B	12	DARK GREEN
W-30	14	DARK BLUE
W-30A	14	DARK BLUE
W-30B	14	DARK BLUE
W-31	14	RED
W-40	14	LIGHT GREEN
W-40B	14	LIGHT GREEN
W-41	14	DARK GREEN
X-3	14	LIGHT GREEN
X-3A	14	LIGHT GREEN
X-3B	14	LIGHT GREEN
X-3C	14	LIGHT GREEN
X-3D	14	LIGHT GREEN
X-32	12	LIGHT BLUE
X-32B	16	LIGHT BLUE
X-32D	16	LIGHT BLUE
X-33	12	ORANGE
X-33A	14	ORANGE
X-33B	14	ORANGE
X-33C	14	ORANGE
X-33D	14	ORANGE
X-33E	14	ORANGE
X-33F	14	ORANGE
X-33G	14	ORANGE
X-33H	14	ORANGE
X-34	12	PINK
X-34A	14	PINK
X-34B	14	PINK
X-34C	16	PINK
X-34D	16	PINK
X-34E	16	PINK
X-34F	16	PINK
X-34G	16	PINK
X-34H	16	PINK
X-35	16	ORANGE
X-35A	16	ORANGE
X-36	16	PINK
X-36A	16	PINK

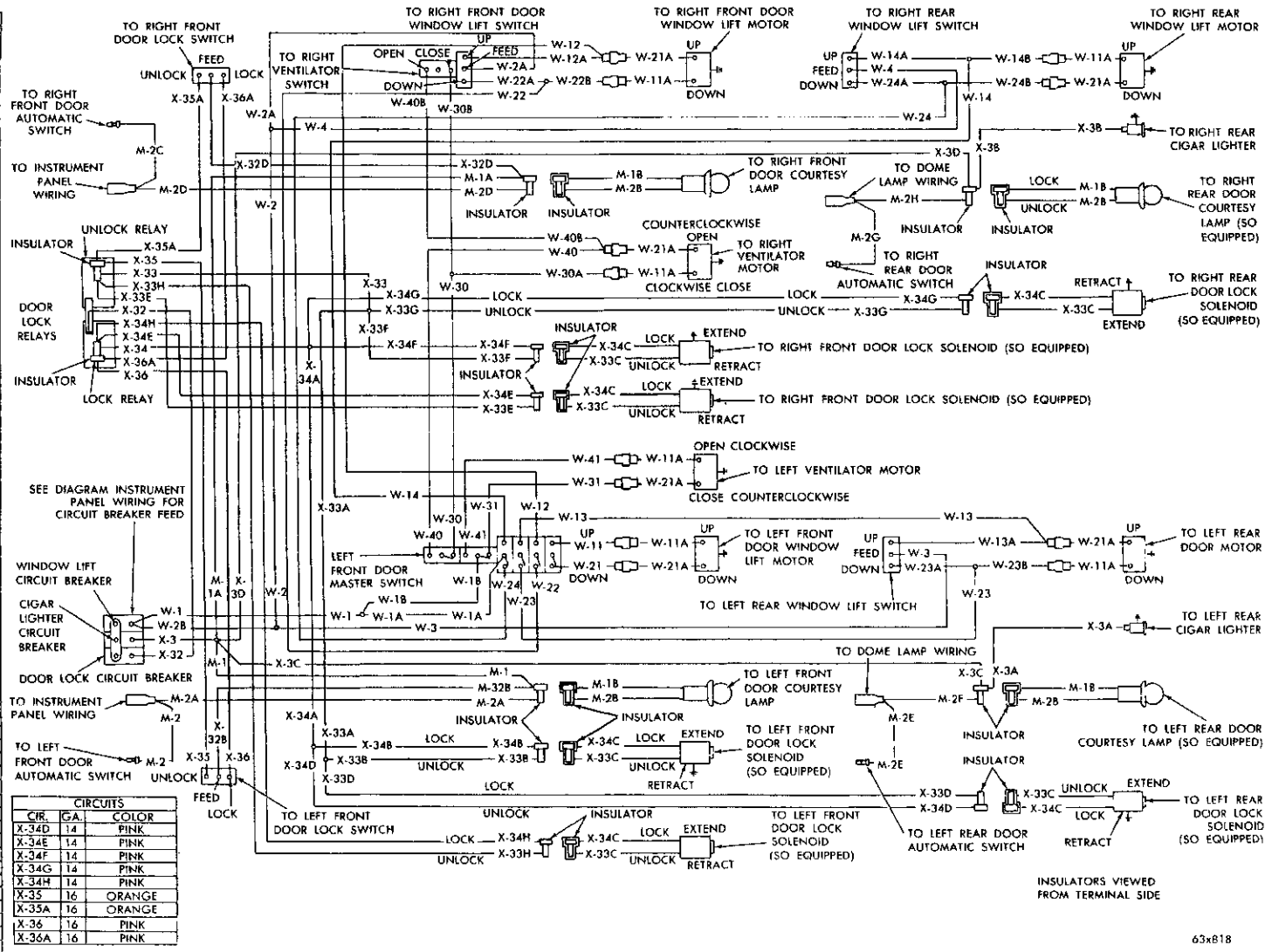
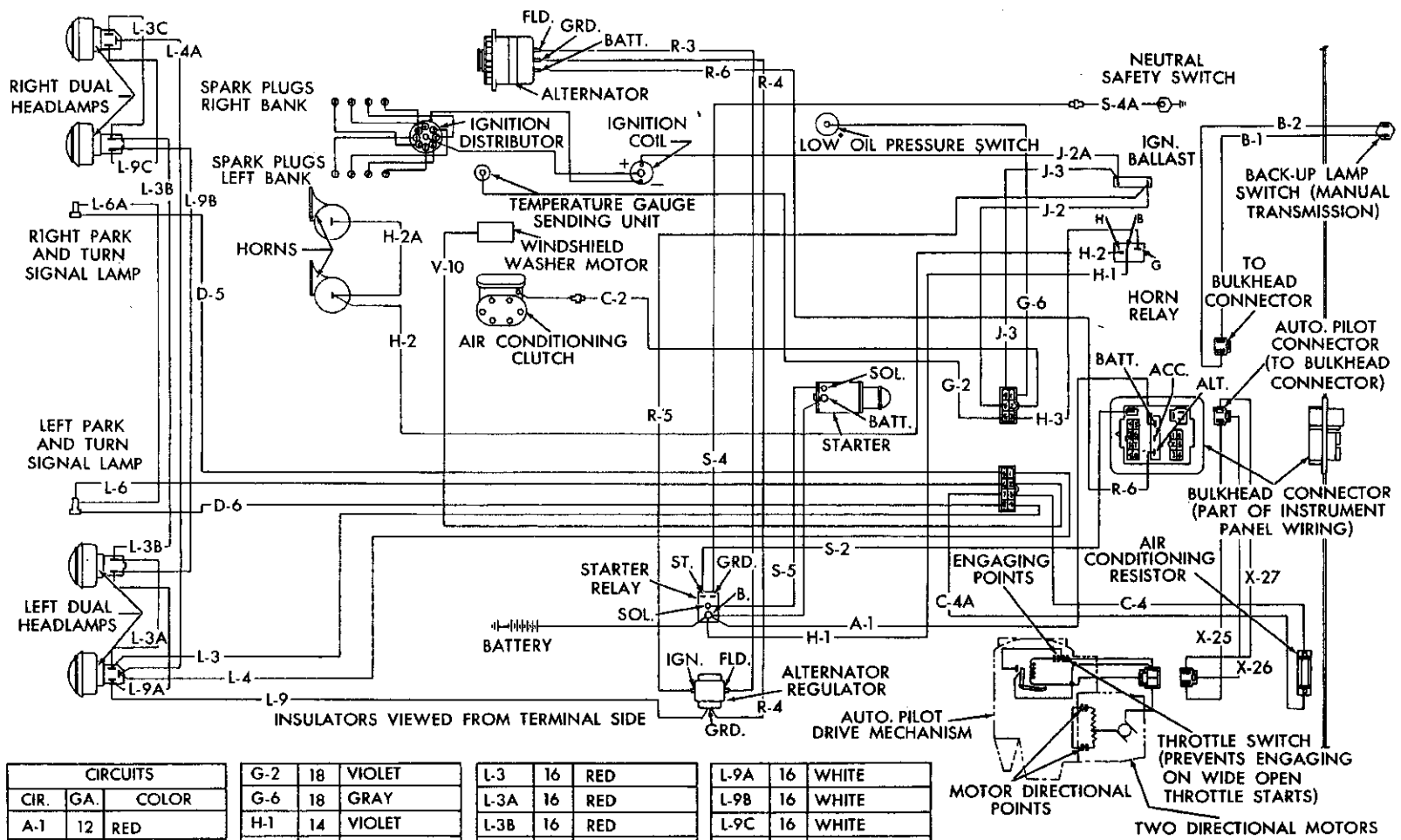

Fig. 139—Electric Window Lift, Power Vent, Door Locks and Cigar Lighter (Imperial)

63x818



CIRCUITS		
CIR.	GA.	COLOR
A-1	12	RED
B-1	18	WHITE
B-2	18	WHITE
C-2	18	BLUE
C-4	16	BROWN
C-4A	16	BROWN
D-5	18	TAN
D-6	18	LIGHT GREEN

G-2	18	VIOLET
G-6	18	GRAY
H-1	14	VIOLET
H-2	16	DARK GREEN
H-2A	16	DARK GREEN
H-3	18	BLACK WITH TRACER
J-2	16	DARK BLUE
J-2A	18	DARK BLUE
J-3	18	BROWN

L-3	16	RED
L-3A	16	RED
L-3B	16	RED
L-3C	16	RED
L-4	16	BLACK
L-4A	16	BLACK
L-6	18	YELLOW WITH TRACER
L-6A	18	YELLOW
L-9	16	WHITE

L-9A	16	WHITE
L-9B	16	WHITE
L-9C	16	WHITE
R-3	18	DARK GREEN
R-4	16	BROWN
R-5	18	DARK BLUE
R-6	12	BLACK
S-2	18	YELLOW
S-4	16	BROWN
S-4A	16	BROWN

S-5	12	BROWN
V-10	18	TAN WITH TRACER
X-25	16	RED
X-26	16	LIGHT BLUE
X-27	16	BLACK

ELECTROMAGNETIC COIL (COIL POINTS KEEP AUTO. PILOT ENGAGED WHEN THROTTLE SWITCH IS OPENED)

63x826

Fig. 140—Engine Compartment (Chrysler)

CIRCUITS		
CIRCUIT	GAUGE	COLOR
A-1	12	RED
C-2	18	LIGHT BLUE
C-4	16	BROWN
C-4A	16	BROWN
D-5	18	TAN
D-6	18	LIGHT GREEN
G-2	18	VIOLET
G-6	18	GRAY
H-1	14	VIOLET
H-2	16	DARK GREEN
H-2A	16	DARK GREEN
H-3	18	BLACK WITH TRACER
J-2	16	DARK BLUE
J-2A	18	DARK BLUE
J-3	18	BROWN
L-3	16	RED
L-3A	16	RED
L-3B	16	RED
L-3C	16	RED
L-3D	16	RED
L-3E	16	RED
L-4	16	BLACK
L-4A	16	BLACK
L-4B	16	BLACK
L-4C	16	BLACK
L-4D	16	BLACK
L-6	18	YELLOW WITH TRACER
L-6A	18	YELLOW
L-6B	18	YELLOW
L-9	16	WHITE
L-9A	16	WHITE
L-9B	16	WHITE
L-9C	16	WHITE
L-9D	16	WHITE
L-9E	16	WHITE
R-3	18	DARK GREEN
R-4	16	BROWN
R-5	18	DARK BLUE
R-6	12	BLACK
S-2	18	YELLOW
S-4	16	BROWN
S-4A	16	BROWN
S-5	12	BROWN
V-10	18	TAN WITH TRACER
X-25	16	RED
X-26	16	LIGHT BLUE
X-27	16	BLACK

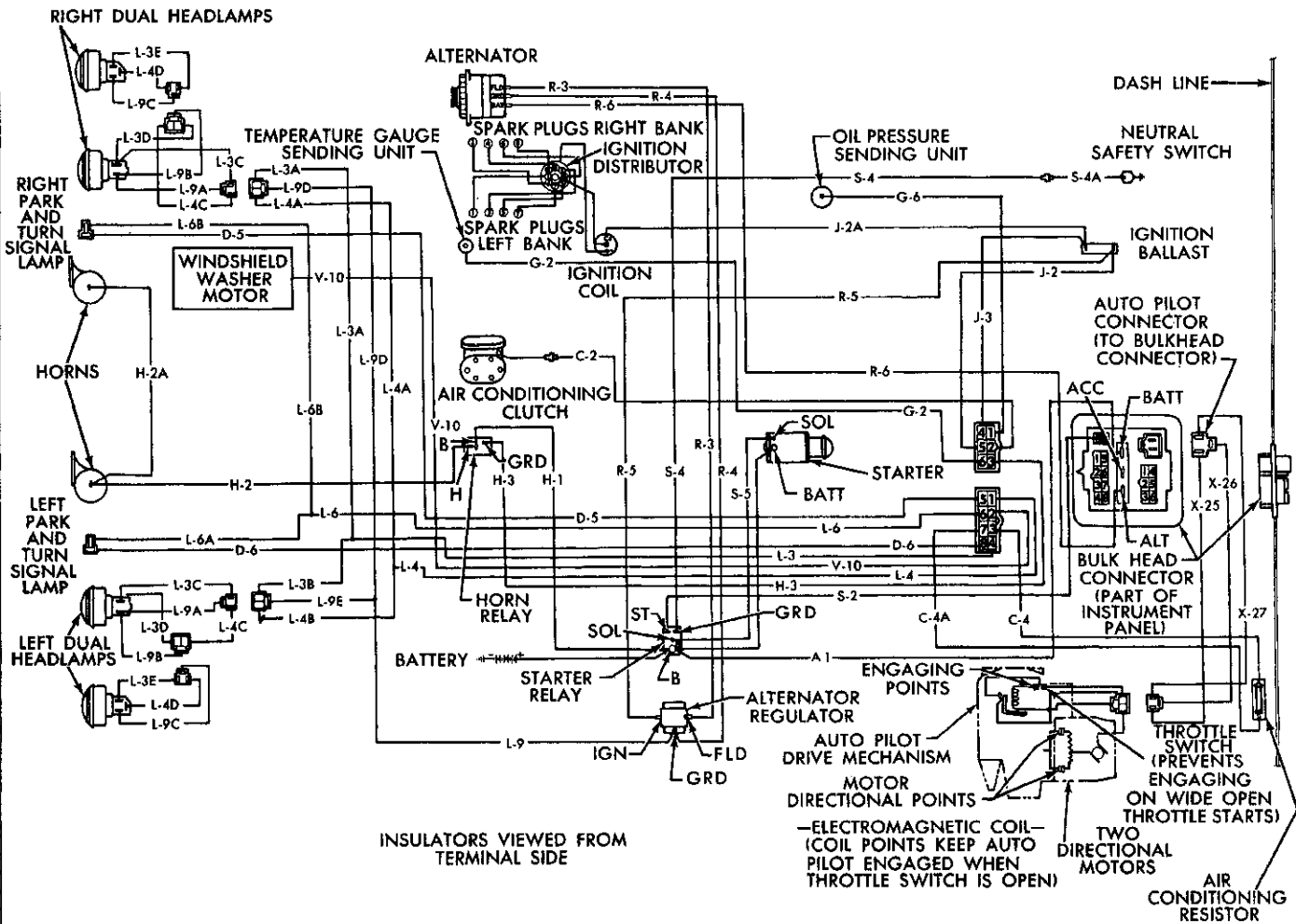

Fig. 141—Engine Compartment (Imperial)

63x827

CIRCUITS		
CIR.	GA.	COLOR
A-1	12	RED
A-1A	12	RED
A-1B	12	RED
B-1	18	WHITE
B-2	18	WHITE
B-1A	18	WHITE
B-2A	18	WHITE
C-1	14	BLACK WITH TRACER
C-2	16	LIGHT GREEN
C-2A	18	LIGHT BLUE
C-4	16	BROWN
C-4A	16	BROWN
C-4B	16	BROWN
C-4C	16	BROWN
C-4D	16	BROWN
C-4E	16	BROWN
C-5	16	DARK GREEN
C-5A	16	DARK GREEN
C-5B	16	DARK GREEN
C-5C	16	DARK GREEN
C-5D	16	DARK GREEN
C-10	18	LIGHT GREEN
C-11	18	BLACK
C-12	18	WHITE
C-20	16	BROWN
C-22	16	DARK GREEN
C-23	16	LIGHT GREEN
C-23A	16	LIGHT GREEN
D-1	18	BLACK
D-2	18	RED
D-3	18	PINK
D-4	18	WHITE
D-5	18	TAN
D-6	18	LIGHT GREEN
D-7	18	BROWN
D-8	18	DARK GREEN
D-9	18	TAN
D-10	18	LIGHT GREEN
E-1	18	TAN
E-2	18	ORANGE

CIRCUITS		
CIR.	GA.	COLOR
E-2A	18	ORANGE
E-2B	18	ORANGE
E-2C	18	ORANGE
E-2D	18	ORANGE
E-2E	18	ORANGE
E-2F	18	ORANGE
E-2G	18	ORANGE
E-4	18	YELLOW WITH TRACER
E-5	18	ORANGE WITH TRACER
E-5A	18	ORANGE WITH TRACER
E-5B	18	ORANGE WITH TRACER

CIRCUITS		
CIR.	GA.	COLOR
G-1	18	BLACK
G-2	18	VIOLET
G-4	18	LIGHT BLUE
G-5	18	DARK BLUE
H-3	18	BLACK WITH TRACER
J-1	12	RED
J-2	16	DARK BLUE
J-3	18	BROWN
L-1	16	BLACK WITH TRACER
L-2	16	LIGHT GREEN

CIRCUITS		
CIR.	GA.	COLOR
L-3	16	RED
L-4	16	BLACK
L-5	18	RED
L-6	18	YELLOW WITH TRACER
L-7	18	BLACK
L-8	18	PINK
M-1	18	PINK
M-1A	18	PINK
M-2	18	YELLOW
M-2A	18	YELLOW
M-2B	18	YELLOW

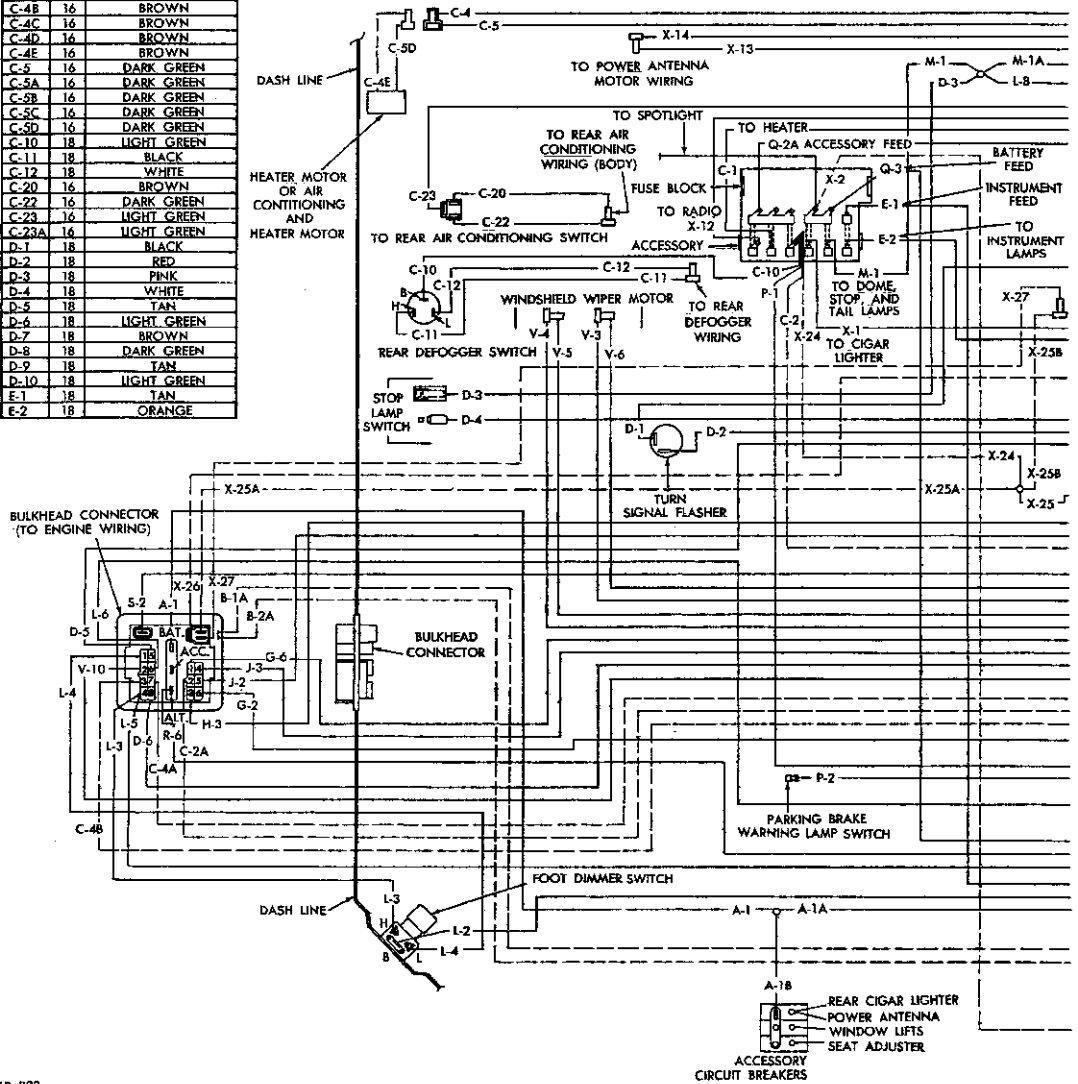

63x822

Fig. 142—Instrument Panel (Chrysler)

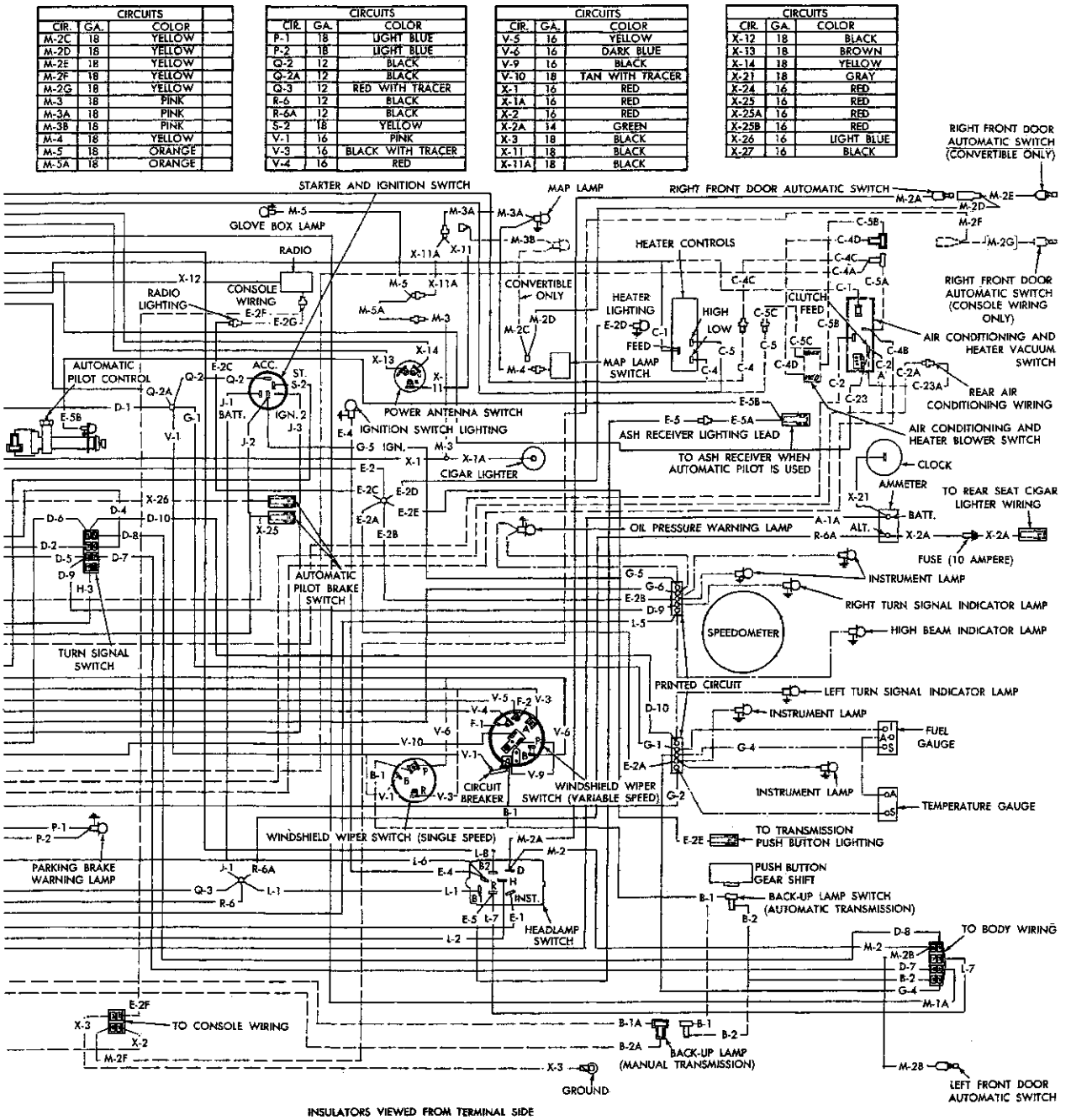

CIR.	GA.	CIRCUITS	COLOR
M-2C	18		YELLOW
M-2D	18		YELLOW
M-2E	18		YELLOW
M-2F	18		YELLOW
M-2G	18		YELLOW
M-3	18		PINK
M-3A	18		PINK
M-3B	18		PINK
M-4	18		YELLOW
M-5	18		ORANGE
M-5A	18		ORANGE

CIR.	GA.	CIRCUITS	COLOR
P-1	18		LIGHT BLUE
P-2	18		LIGHT BLUE
Q-2	12		BLACK
Q-3	12		RED WITH TRACER
R-6	12		BLACK
R-6A	12		BLACK
S-2	18		YELLOW
V-1	16		PINK
V-3	16		BLACK WITH TRACER
V-4	16		RED

CIR.	GA.	CIRCUITS	COLOR
V-5	16		YELLOW
V-6	16		DARK BLUE
V-9	16		BLACK
V-10	18		TAN WITH TRACER
X-1	16		RED
X-1A	16		RED
X-2	16		RED
X-2A	14		GREEN
X-3	18		BLACK
X-11	18		BLACK
X-11A	18		BLACK

CIR.	GA.	CIRCUITS	COLOR
X-12	18		BLACK
X-13	18		BROWN
X-14	18		YELLOW
X-21	18		GRAY
X-24	16		RED
X-25	16		RED
X-25A	16		RED
X-25B	16		RED
X-26	16		LIGHT BLUE
X-27	16		BLACK

Fig. 142—Instrument Panel (Chrysler)

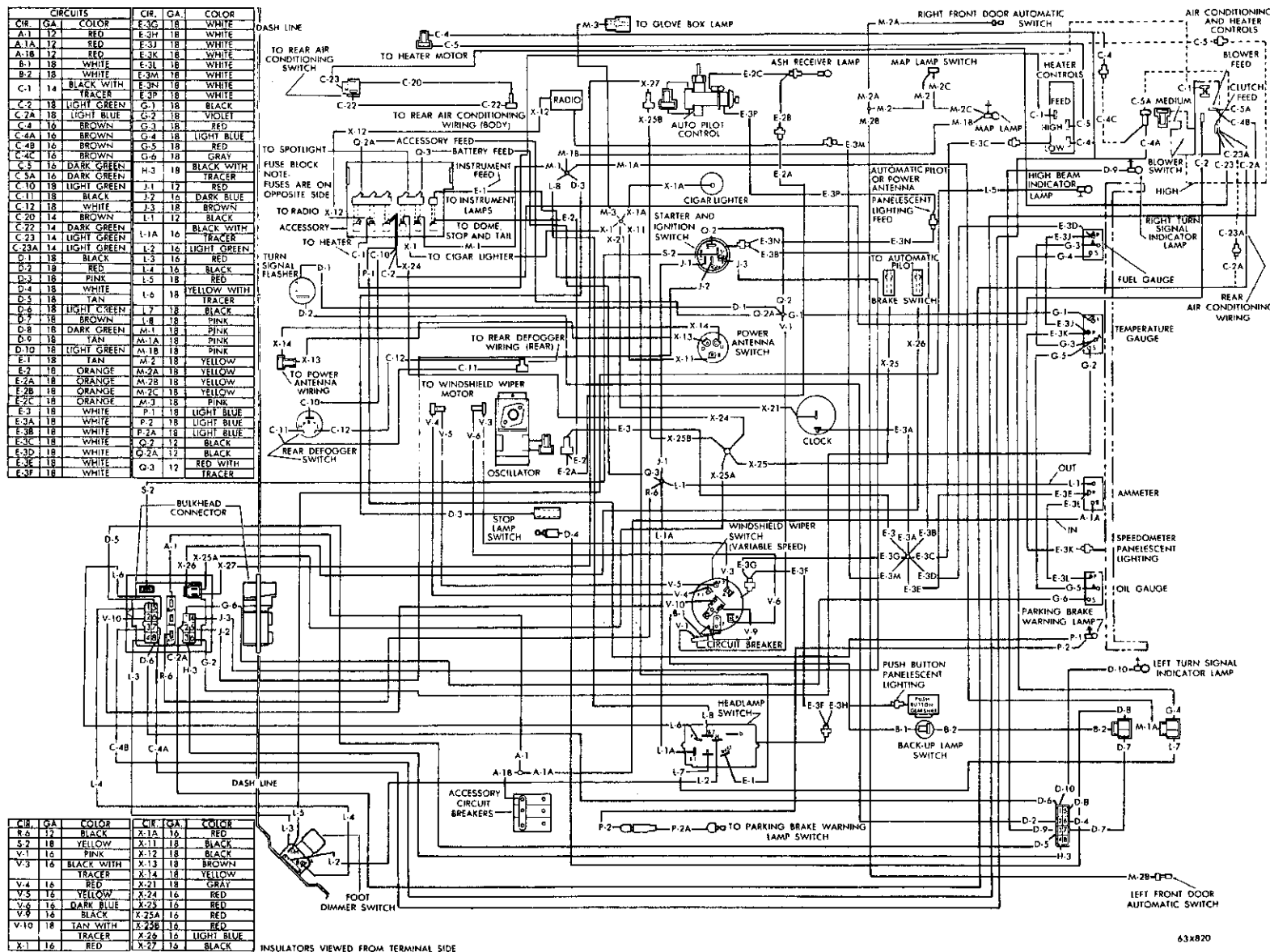

SERVICE DIAGNOSIS

PART 1

BATTERY TESTING CHART

93. Hydrometer Test (Corrected to 80° F.)		
	State of Charge or Battery Condition	Correction
Less than 1.220 SP. GR.	Battery low.	Recharge the battery. Give high rate discharge test for capacity. If the cells test O.K., recharge and adjust the gravity of all cells uniformly. Test the voltage regulator setting. Thoroughly test the electrical system for short circuits, loose connections, corroded terminals, etc.
Cells show more than 25 points (.025 Specific Gravity) variation.	Short circuit in low cell. Loss of electrolyte by leakage or excessive overcharge. Improper addition of acid. Natural or premature failure. Cracked case.	Try to recharge the battery. See "Charging the Battery". Test battery for capacity. Install a new battery if necessary.
94. Open Circuit Voltage Test		
	State of Charge or Battery Condition	Correction
Cells showing more than 1.220 specific gravity.	Satisfactory	No correction required if variation among cells is not over .05 volts. If variation is more than .05 volts, recharge. Give high rate discharge capacity test, if cells test O.K., adjust gravity of all cells uniformly.
Cells showing less than 1.220 specific gravity, but not more than .05 volts variation.	Questionable	Recharge battery. Give high rate discharge test for capacity. If cells test O.K., recharge. Test voltage regulator setting. Thoroughly test the electrical system for short circuits, loose connections, corroded terminals, etc.
Cells showing more than .05 volts variation.	(a) Short circuit in low cell. (b) Loss of electrolyte by leakage or excessive overcharge. (c) Improper addition of acid or "Dopes". (d) Natural or premature failure. (e) Cracked case.	Recharge battery. See "Charging the Battery".
95. Cranking Test		
	Possible Cause	Correction
If the voltage drop is more than 0.3 volts ($\frac{3}{10}$) between the starting motor cable and the vehicle frame while cranking look for:	Poor contact between cable terminal and vehicle frame or between cable clamp terminal and battery post or starter switch contacts. Frayed, corroded or broken cable.	Locate the high resistance: repair or replace as necessary.

SERVICE DIAGNOSIS—(Continued)

BATTERY TESTING CHART

Cranking Test	Possible Cause	Correction
While operating the starting motor, ignition "OFF" check the voltage of all cells. If the voltage varies more than 0.15 volt between cells, look for:	Faulty cell or cells.	Compare voltage readings with hydrometer reading—low voltage is usually accompanied by low gravity. Try to recharge the battery. See "Charging the Battery".

PART 2

STARTING MOTOR

Condition	Possible Cause	Correction
96. Starter Fails to Operate	(a) Weak battery.	(a) Test for specific gravity and test for dead cell. Replace or recharge the battery as required.
	(b) Ignition switch faulty.	(b) Test and replace the switch if necessary.
	(c) Loose or corroded battery cable terminals.	(c) Clean terminals and clamps, replace if necessary. Apply a light film of vasoline to terminals. Tighten clamps securely.
	(d) Open circuit, wire between the ignition-starter switch and ignition terminal on the starter relay.	(d) Inspect and test all the wiring.
	(e) Inoperative clutch unit.	(e) Replace the clutch unit.
	(f) Faulty starting motor.	(f) Test and repair.
	(g) Armature shaft sheared.	(g) Test and repair.
97. Starter Fails and Lights Dim	(a) Weak battery.	(a) Test for specific gravity and inspect for dead cell. Replace or recharge the battery as required.
	(b) Loose or corroded battery cable terminals.	(b) Clean the terminals and clamps, replace if necessary. Apply a light film of vasoline to the terminals. Tighten the clamps securely.
	(c) Internal ground in wiring.	(c) Test and repair the starter.
	(d) Grounded starter fields.	(d) Test and repair the starter.
	(e) Armature rubbing on pole shoes.	(e) Test and repair the starter.
98. Starter Turns, But Pinion Does Not Engage	(a) Starter clutch slipping.	(a) Replace the clutch unit.
	(b) Broken teeth on flywheel drive gear.	(b) Replace the flywheel ring gear. Also examine teeth on the starter clutch pinion gear.
	(c) Pinion shaft rusted, dirty or dry, due to lack of lubrication.	(c) Clean, test and lubricate.
	(d) Wrong starter pinion clearance.	(d) Adjust pinion clearance.

SERVICE DIAGNOSIS—(Continued)

STARTING MOTOR

Condition	Possible Cause	Correction
99. Starter Relay Does Not Close	(a) Battery discharged.	(a) Recharge or replace the battery.
	(b) Faulty wiring.	(b) Test for open circuit, wire between the starter relay ground terminal post and neutral starter switch (automatic transmission only). Also test for open circuit, wire between ignition-starter switch and ignition terminal and starter relay.
	(c) Neutral starter switch on automatic transmission faulty.	(c) Test and replace the switch if necessary.
	(d) Starter relay faulty.	(d) Test and replace if necessary.
	(e) Ignition-starter switch faulty.	(e) Test and replace switch if necessary.
100. Relay Operates But Solenoid Does Not	(a) Faulty wiring, open circuit wire between the starter-relay and solenoid terminal and solenoid terminal post.	(a) Test for open circuit wire between the starter-relay solenoid terminal and solenoid terminal post.
	(b) Faulty solenoid switch or connections.	(b) Test for loose terminal connections between solenoid and starter field.
	(c) Solenoid switch contacts corroded.	(c) Test and replace the solenoid if necessary.
	(d) Broken lead or loose soldered connection inside solenoid switch cover (brush holder plate).	(d) Test and replace the solenoid if necessary.
101. Solenoid Plunger Vibrates Back and Forth When Switch is Engaged	(a) Weak battery.	(a) Test for specific gravity of the battery. Replace or recharge the battery.
	(b) Faulty wiring.	(b) Test for loose connections at relay, ignition-starter switch and solenoid. Repair as necessary.
	(c) Lead or connections broken inside solenoid switch cover (brush holder Plate) or open hold-in winding.	(c) Test and replace the solenoid if necessary.
	(d) Check for corrosion on solenoid contacts.	(d) Test and clean the contacts.
102. Starter Operates But Will Not Disengage When Ignition Starter is Released	(a) Broken solenoid plunger spring or spring out of position.	(a) Test and repair.
	(b) Faulty ignition-starter switch.	(b) Test and replace the switch if necessary.
	(c) Solenoid contact switch plunger stuck in solenoid.	(c) Remove the contact switch plunger, wipe clean of all dirt, place a film of SAE 10 oil on the plunger, wipe off excess.
	(d) Insufficient clearance between winding leads to solenoid terminal and main contactor in solenoid.	(d) Test and repair.
	(e) Faulty relay.	(e) Test and replace the relay if necessary.

SERVICE DIAGNOSIS

PART 3

ALTERNATOR

Condition	Possible Cause	Correction
103. Alternator Fails to Charge (No Output)	(a) Blown fusible wire in voltage regulator.	(a) Locate and correct the cause of the fuse blowing. Install a new fuse wire. Solder both ends of a new fusible wire securely.
	(b) Alternator drive belt loose.	(b) Adjust the drive belt according to Specifications under "Cooling Group".
	(c) Worn brushes and/or slip rings.	(c) Install new brushes and/or slip rings.
	(d) Sticking brushes.	(d) Clean the slip rings and brush holders. Install new brushes.
	(e) Open field circuit.	(e) Test all the field circuit connections, and correct as required.
	(f) Open charging circuit.	(f) Inspect all connections in the charging circuit, and correct as required.
	(g) Open circuit in stator windings.	(g) Remove the alternator and disassemble. Test the stator windings. Install a new stator if necessary.
	(h) Open rectifiers.	(h) Remove the alternator and disassemble. Test the rectifiers. Install new rectifiers if necessary.
104. Low, Unsteady Charging Rate	(a) Alternator drive belt loose.	(a) Adjust the alternator drive belt. See "Cooling Group".
	(b) High resistance at battery terminals.	(b) Clean and tighten the battery terminals.
	(c) High resistance in the charging circuit.	(c) Test the charging circuit resistance. Correct as required.
	(d) High resistance in the body to engine ground lead.	(d) Tighten the ground lead connections. Install a new ground lead if necessary.
	(e) Open stator windings.	(e) Remove and disassemble the alternator. Test the stator windings. Install a new stator if necessary.
105. Low Output and a Low Battery	(a) High resistance in the charging circuit.	(a) Test the charging circuit resistance and correct as required.
	(b) Low regulator setting.	(b) Adjust the voltage regulator as necessary.
	(c) Shorted rectifier. Open rectifier.	(c) Perform the current output test. Remove and disassemble the alternator. Test the rectifiers. Install new rectifiers as required.
	(d) Grounded Stator windings.	(d) Remove and disassemble the alternator. Test the stator windings. Install a new stator if necessary.

SERVICE DIAGNOSIS— (Continued)
ALTERNATOR

Condition	Possible Cause	Correction
106. Excessive Charging Rate to a Fully Charged Battery	(a) Regulator set too high.	(a) Reset the voltage regulator according to Specifications.
	(b) Regulator contacts stuck.	(b) Install a new voltage regulator.
	(c) Regulator voltage winding open.	(c) Install a new voltage regulator.
	(d) Regulator base improperly grounded.	(d) Correct the regulator base to the ground connection.
107. Regulator Contacts Burned	(a) High regulator setting.	(a) Reset the voltage regulator according to specifications.
	(b) Shorted rotor field coil windings.	(b) Test the rotor field coil current draw. If excessive install a new rotor.
108. Regulator Contacts Points Stuck	(a) Poor ground connection between the alternator and the regulator. Open resistor element.	(a) Correct the ground connection. Install a new regulator. Test the regulator setting, and reset if necessary.
109. Noisy Alternator	(a) Alternator mounting loose.	(a) Properly install and tighten the alternator mounting.
	(b) Worn or frayed drive belt.	(b) Install a new drive belt and adjust. See Cooling Group.
	(c) Worn bearings.	(c) Remove and disassemble the alternator. Install new bearing as required.
	(d) Interference between the rotor fan and stator leads or rectifiers.	(d) Remove and disassemble the alternator. Correct the interference as required.
	(e) Rotor or rotor fan damaged.	(e) Remove and disassemble the alternator. Install a new rotor.
	(f) Open or shorted rectifier.	(f) Remove and disassemble the alternator. Test the rectifiers. Install new rectifiers as required.
	(g) Open or shorted winding in the stator.	(g) Remove and disassemble the alternator. Test the stator windings. Install a new stator if necessary.

IGNITION SYSTEM
PART 4

Condition	Possible Cause	Correction
110. Burned or Pitted Distributor Points	(a) Dirt or oil on points.	(a) If the oil is on contact face, determine the cause and correct the condition. Clean the distributor cam of dirt and grease, apply a light film of distributor cam lubricant Number 1473595 to cam lobes; wipe off the excess. Replace the point set and adjust as necessary.

SERVICE DIAGNOSIS—(Continued)
IGNITION SYSTEM

Condition	Possible Cause	Correction
	(b) Alternator regulator setting too high.	(b) Test the alternator voltage regulator setting, adjust as necessary. Replace and adjust the distributor contact points.
	(c) Points misaligned or gap too small.	(c) Align and adjust points.
	(d) Faulty coil.	(d) Test and replace coil if necessary. Replace and adjust contact points.
	(e) Ballast resistor not in circuit.	(e) Inspect conditions, and correctly connect the coil.
	(f) Wrong condenser or faulty condenser.	(f) Test the condenser and replace if necessary. Replace and adjust points.
	(g) Faulty ignition switch.	(g) Replace the ignition switch.
	(h) Bushings or distributor shaft worn.	(h) Recondition the distributor.
	(i) Touching of points with hands during installation.	(i) Replace and adjust the contacts.
111. Ignition Coil Failure	(a) Alternator regulator setting too high.	(a) Test the alternator setting and adjust as necessary. Inspect the condition of the distributor contact points.
	(b) Coil damaged by excessive heat from engine.	(b) Replace coil. Inspect the condition of the distributor contact points.
	(c) Coil case or tower cracked.	(c) Replace the coil.
	(d) Oil leak at tower.	(d) Replace the coil.
	(e) Coil tower carbon-tracked.	(e) Wipe the tower clean. Test the coil, replace if necessary.
112. Condenser Failure	(a) Normal fatigue.	(a) Test and replace the condenser. Inspect distributor contact points for pitting.
	(b) Damaged by excessive engine heat or moisture.	(b) Test and replace the condenser. Inspect distributor contact points for pitting.
113. Fouled Spark Plugs	(a) Carburetor mixture over-rich.	(a) Adjust the carburetor. Refer to Group 14 "Fuel System".
	(b) Improper gap adjustment.	(b) Set the spark plug gap to .035 inch.
	(c) Improper plug heat range.	(c) Install the correct plugs.
114. Burned Spark Plugs	(a) Plugs loose or too tight in the cylinder head.	(a) Replace the spark plugs: Install new gaskets. Tighten spark plugs to 30 foot-pounds torque.
	(b) Carburetor mixture too lean.	(b) Adjust the carburetor. Refer to Group 14 "Fuel System".
	(c) Improper plug heat range.	(c) Install the correct plugs.
	(d) Improper ignition Timing.	(d) Adjust the ignition timing.

**SERVICE DIAGNOSIS
PART 5
ELECTROLUMINESCENT LIGHTING (IMPERIAL)**

Condition	Possible Cause	Correction
115. One Instrument Fails to Glow	(a) Disconnected lead or broken lead to the instrument dial.	(a) Connect or repair, or replace the instrument if necessary.
116. Instrument Glows but Pointer Fails to Glow	(a) Broken lead to the pointer within the instrument.	(a) Repair the lead or replace the instrument if necessary.
117. All Instruments Fail to Glow	(a) A possible faulty panel lamp switch.	(a) Test the operation of the switch using a test lamp. Install new switch if necessary.
	(b) A possible faulty power unit.	(b) Test the power unit. See "Instrument Testing with Tool C-3764".

THERMAL TYPE GAUGES

118. All Gauges Read High (against the peg) After Ignition Switch is Turned "ON"	(a) Defective constant voltage limiter (stuck points or open heater coil).	(a) Test the voltage limiter.
119. Gauge Pointers Do Not Move When Ignition Switch is Turned "ON"	(a) Malfunctioning constant voltage limiter or an open circuit on battery side (input of limiter).	(a) Test voltage limiter.
120. Fuel Gauge Indicates Higher or Lower Level Than Actually Exists.	(a) Fuel tank sending unit or instrument panel fuel gauge is faulty.	(a) Test fuel tank for a good ground.
121. Temperature Gauge Indicates Higher or Lower Temperature than Actual Engine Temperature	(a) Defective instrument panel temperature gauge, wiring or defective temperature sending unit in engine.	(a) Test gauge, sending unit, and wiring. Repair or replace as necessary.
122. Oil Gauge Indicates Higher or Lower Pressure than Actually Exists	(a) Defective gauge, wiring, or oil pressure sending unit in engine.	(a) Test oil pressure indicating system.
123. Erratic Temperature Gauge Operation	(a) Loose or dirty electrical connections.	(a) Clean and tighten all electrical connections and recheck the gauge operation.
124. Erratic Operation of Fuel Gauge	(a) Loose or dirty electrical connections or defective fuel tank sending unit.	(a) Test the fuel gauge sending unit, and proceed as follows: (1) Clean and tighten all electrical connections. (2) Make sure that the fuel tank sending unit is grounded to tank and that tank is grounded to the frame. Check ground clip at tank unit for proper installation.

SERVICE DIAGNOSIS

PART 6

HEADLAMPS

Condition	Possible Cause	Correction
125. Headlamps Dim (Engine Idling or Shut Off)	(a) Partly discharged battery.	(a) Charge battery.
	(b) Faulty cells in battery.	(b) Test and replace battery if necessary.
	(c) High resistance in light circuit.	(c) Test headlight circuit including ground connection. Make necessary repairs.
	(d) Faulty sealed beam units.	(d) Replace sealed beam units.
126. Headlamps Dim (Engine Running Above Idle)	(a) High resistance in lighting circuit.	(a) Test lighting circuit including ground connection. Make necessary repairs.
	(b) Faulty sealed beam units.	(b) Replace sealed beam units.
	(c) Faulty voltage regulator unit.	(c) Test voltage regulator and alternator. Make necessary repairs.
127. Lamps Flicker	(a) Loose connections or damaged wires in lighting circuit.	(a) Tighten connections and check for damaged wiring.
	(b) Light wiring insulation damaged producing momentary short.	(b) Test light wiring and replace or tape damaged wires.
128. Lamps Burn Out Frequently	(a) High voltage regulator setting.	(a) Adjust voltage regulator.
	(b) Loose connections in light circuit.	(b) Tighten connections.
129. Lamps Will Not Light	(a) Discharged battery.	(a) Recharge battery and correct cause.
	(b) Loose connections in lighting circuit.	(b) Tighten connections.
	(c) Burned out lamps.	(c) Replace bulbs or sealed beam unit.
	(d) Open or corroded contacts in lighting switch.	(d) Test and replace lighting switch if necessary.
	(e) Open or corroded contact in dimmer switch.	(e) Test and replace dimmer switch if necessary.

DIRECTIONAL INDICATORS

130. External Lamps Operate Normally, No Indication on Instrument Cluster	(a) Faulty pilot bulb in instrument cluster.	(a) Replace faulty bulb.
131. System Does Not Flash	(a) Faulty flasher unit.	(a) Replace flasher.
	(b) Faulty external bulb.	(b) Replace faulty bulb.
	(c) Faulty contact in switch.	(c) Replace switch.
132. System Does Not Cancel After Completion of Turn	(a) Broken or loose cancelling finger.	(a) Replace cancelling finger.
	(b) Improperly aligned cancelling finger.	(b) Align cancelling finger properly.
	(c) Broken or faulty switch.	(c) Replace switch.
133. Entire System Does Not Operate	(a) Open circuit in feed wire to switch.	(a) Test wiring circuits. Refer to Wiring Diagram.

SERVICE DIAGNOSIS—(Continued)**DIRECTIONAL INDICATORS**

Condition	Possible Cause	Correction
134. Pilot Lamp Illuminates Brightly, External Lamps Glows Dimly With No Flash	(a) Loose or corroded external ground connection.	(a) Clean and tighten ground connection.

PART 7**HORNS**

135. Horns Will Not Blow	(a) Improper adjustment. (b) Broken or faulty wiring. (c) Faulty horn. (d) Faulty relay.	(a) See "Adjusting Horns". (b) See Testing Horns. (c) See Testing Horns. Replace if necessary. (d) See Testing Horns. Replace relay if necessary.
136. Horns Blow Continuously	(a) Shorted wiring. (b) Horn button sticking. (c) Relay sticking.	(a) See Testing Horns. (b) Disconnect battery ground cable. Release horn button. After correction, reconnect battery ground cable. (c) Replace relay.

WINDSHIELD WIPERS

137. Wiper Operates Slowly	(a) Binding linkage. (b) High resistance in brush to commutator contact, or carbon deposits in slots. (c) High resistance in ground connection. (d) Faulty control switch.	(a) Relieve the binding condition. Add lubriplate to moving parts. (b) Test the armature commutator and brushes. Repair as necessary. (c) Test for high resistance in ground connection and/or wiring circuit. (d) Replace the switch.
138. Wiper Fails to Operate	(a) Binding linkage. (b) Faulty switch. (c) Faulty motor. (d) Open or grounded wiring.	(a) Relieve the binding condition. Add light film of lubriplate to moving parts. (b) See switch testing procedures under "Windshield Wiper Switch". (c) Test and repair. See "Bench Testing Wiper Motor." (d) Test for continuity. Repair wiring as necessary.
139. Wiper Blades Not Parking Properly	(a) Broken link spring. (b) Link spring not releasing. (c) Link spring trip not engaging stop on linkage.	(a) Replace the spring. See "Assembly of Wiper Link". (b) Inspect "Assembly of Wiper Link". (c) Inspect "Assembly of Wiper Link".
140. Blades Slap Windshield Mouldings	(a) Improperly adjusted wiper arm. (b) Looseness of the motor lever or other drive parts.	(a) Adjust wiper arm. (b) Replace the defective part.

SERVICE DIAGNOSIS—(Continued)

WINDSHIELD WIPERS

Condition	Possible Cause	Correction
141. Blades Chatter	(a) Twisted arm holds blade at wrong angle to glass.	(a) Replace the wiper arm. Do not attempt to straighten a bent or twisted arm.
	(b) Wrong type blades used.	(b) Install the correct wiper blades.
	(c) Wax on glass.	(c) Clean the glass.
142. Motor Will Not Park	(a) Parking spring in the parking switch plate is bent too low and is not breaking contact.	(a) Inspect and adjust the switch plate spring.
	(b) Dirty or worn motor switch contact points.	(b) Clean the contacts, if excessively worn. Replace the switch.

PART 8

POWER SEATS

143. Entire Unit Inoperative	(a) Broken wire or loose connections in any part of motor control circuit.	(a) Test the Wiring, repair or replace as necessary.
144. Motor Inoperative	(a) Short or open circuit between power source or faulty relay, switch or motor.	(a) Test the red wire at the relay with a test light.
	(b) Faulty motor.	(b) Repair or replace the motor.
145. Seat Inoperative (Motor Runs)	(a) Short or open circuit between the switch and affected solenoid.	(a) Jump the wire from the number 10 feed wire to each solenoid terminal on the clutch assembly. Each solenoid should "click" as the jumper is connected. If solenoid does not click: Test the wire in the harness for an open circuit. Repair. Test for a possible seized solenoid armature in the coil. Replace the coil. Test for a possible burned-out solenoid. Replace the solenoid.
146. Seat Inoperative (Motor Runs and Solenoid Clicks)	(a) Possible stripped or broken gear in the drive unit.	(a) Inspect and replace the drive unit if necessary.
147. Slave Unit Inoperative (Motor, Solenoids and Drive Unit O.K.)	(a) Possible broken drive cable.	(a) Inspect and replace the parts as necessary.
148. Seat Track Excessively Loose (A Loose Rivet Joint)	(a) Loose rivet joints.	(a) Disassemble the upper track seat support (B) by removing the cotter keys and pins. Remove the seat support and tighten all the riveted joints (J) by peening with a ball peen hammer.
149. Loose Front Levers	(a) Movement between the two sections comprising the front lever assembly (Fig. 99).	(a) Arc weld the front levers (K) to prevent movement between the two sections.

SERVICE DIAGNOSIS—(Continued)

POWER SEATS

Condition	Possible Cause	Correction
150. Seat Chuck Fore and Aft	(a) Loose horizontal rack support arm to lower track base.	(a) Repair as follows: (1) Remove the seat track assembly from the vehicle and arc weld as shown (L). (2) Tighten the rack attaching pins (N) by arc welding.
	(b) Loose horizontal rack in slave unit gear train.	(b) Replace the slave unit.

ELECTRIC WINDOW LIFTS

151. A Window Will Not Operate from the Master Switch, But Can Be Operated From the Individual Door Switch	(a) Faulty switch in the master switch group.	(a) Replace master switch.
	(b) Break in the wire at the door opening, or at the door holding the master switch group.	(b) Test for continuity, see Wiring Diagram. Repair wiring. Avoid making a splice in the flexing sections of the wiring harness.
152. None of the Windows Will Operate from the Master Switch or From the Individual Door Switch	(a) Faulty circuit breaker—located above left cowl panel.	(a) Replace circuit breaker and test the new circuit breaker to determine if voltage is present at the terminal opposite the battery feed.
	(b) Open in the battery feed wire from the circuit breaker to the alternator (ammeter).	(b) Test for continuity and repair as necessary.
153. A Window Cannot be Operated From Either the Master Switch or the Individual Door Switch	(a) Test for faulty circuit breaker—located above left cowl pane.	(a) Replace circuit breaker.
	(b) Master switch and door switch inoperative.	(b) Test the master switch and door switch for continuity.
	(c) Open in wire between motor and switch.	(c) Test for continuity between the motor and the switch. Repair wiring as necessary.
	(d) Jammed gear box.	(d) Test and repair. Inspect motor to gear box alignment.
	(e) Coupling broken between the motor and the gear box.	(e) Replace coupling and test motor and gear box alignment.
	(f) Lift motor burned out.	(f) Repair or replace lift motor. Test for sticking door switch as possible cause of motor failure.
	(g) Short in the wiring circuit.	(g) Inspect and test wiring. See "Wiring Diagrams".
154. A Window Will Operate in One Direction Only When Controlled by Either the Master Switch or by the Individual Door Switch	(a) Faulty circuit between master switch and door switch.	(a) Test the master switch and door switch for continuity. Check for continuity between the motor leads and the switch.
	(b) If the window can be moved by rotating the coupling between the motor and the gear box.	(b) Remove the window lift motor and test on bench with battery voltage. See "Wiring Diagram".
	(c) Lift motor burned out.	(c) Test for sticking switch.

SERVICE DIAGNOSIS—(Continued)
ELECTRIC WINDOW LIFTS

Condition	Possible Cause	Correction
	(d) Short in wiring circuit.	(d) Inspect and test all wiring. See "Wiring Diagram".
155. Circuit Breaker Clicks "On" and "Off" Continuously and Window Does Not Operate	(a) Short in the feed wire that feeds the right front and rear doors. (b) A faulty switch.	(a) Test the wiring, repair or replace as necessary. (b) Replace the switch.
