

**GROUP 5
BRAKES
CONTENTS**

| | Page | | Page |
|-----------------------------------|------|---|------|
| Booster Brakes | | | |
| Booster Brake (Bendix)..... | 13 | Remote Power Brake (C-300J)..... | 19 |
| Booster Brake (Midland Ross)..... | 16 | Service Diagnosis..... | 25 |
| Parking Brakes | | | |
| Parking Brake Adjustment..... | 10 | Parking Brake Cable (Rear)..... | 10 |
| Parking Brake Cable (Front)..... | 12 | Service Diagnosis..... | 22 |
| Service Brake | | | |
| Adjusting the Brakes..... | 2 | Grinding Recommendations..... | 5 |
| Bleeding the Brake System..... | 6 | Master Cylinder..... | 7 |
| Brake Drums..... | 3 | Service Diagnosis..... | 23 |
| Brake Shoe Installation..... | 5 | Test for Fluid Contamination..... | 9 |
| Brake Shoe Removal..... | 4 | Testing Automatic Adjuster Operation..... | 3 |
| Brake Support Plates..... | 8 | Wheel Cylinders..... | 7 |
| | | Wheel Stud Tightening..... | 9 |

SPECIFICATIONS

| | TC-1 | TC-2, TC-3 | TY-1 |
|--------------------------------|-------------------------|------------|-------|
| Type..... | Duo-Servo Single Anchor | | |
| Drum Diameter..... | 11 in. | | |
| (Police & Heavy Duty)..... | 11 in. | | |
| Number of Brake Shoes..... | 8 | | |
| Width | | | |
| Front..... | | 3 in. | |
| Rear..... | 2½ in. | 3 in. | 3 in. |
| (Police & Heavy Duty) | | | |
| Front..... | 3 in. | | |
| Rear..... | 3 in. | | |
| Brake Lining..... | Bonded Moulded Asbestos | | |
| Front Primary..... | 12⅞" | | |
| Front Secondary..... | 12⅞" | | |
| Rear Primary..... | 12⅞" | | |
| Rear Secondary..... | 12⅞" | | |
| (Police & Heavy Duty) | | | |
| Front Primary..... | 9¼ in. | | |
| Front Secondary..... | 12⅞ in. | | |
| Rear Primary..... | 9¼ in. | | |
| Rear Secondary..... | 12⅞ in. | | |
| Thickness (all)..... | ¾ in. | | |
| Wheel Cylinder | | | |
| Front Wheel Cylinder Bore..... | 1⅛ in. | | |
| Rear Wheel Cylinder Bore..... | 1⅝ in. | | |
| Master Cylinder Bore..... | 1 in. | | |

TORQUE REFERENCE

| | |
|--|--------------|
| Mounting Bracket to Firewall Nuts | 100 in.-lbs. |
| Master Cylinder to Vacuum Cylinder Nut | 100 in.-lbs. |
| Wheel Stud Nuts | 60 ft.-lbs. |

**GROUP 5
BRAKES**

SERVICE BRAKES

The 1963 Models have a new self adjusting, duo-servo, two shoe, internal expanding brake. The lower

ends of the brake shoes are connected by a tubular star wheel adjusting screw, as shown in Figures 1 or 2.

SERVICE PROCEDURES

1. ADJUSTING THE BRAKES

Hydraulic brake adjustment is made by a single adjustment at each wheel.

(1) Jack up the vehicle so all wheels are free to turn.

(2) Remove the rear adjusting hole cover from

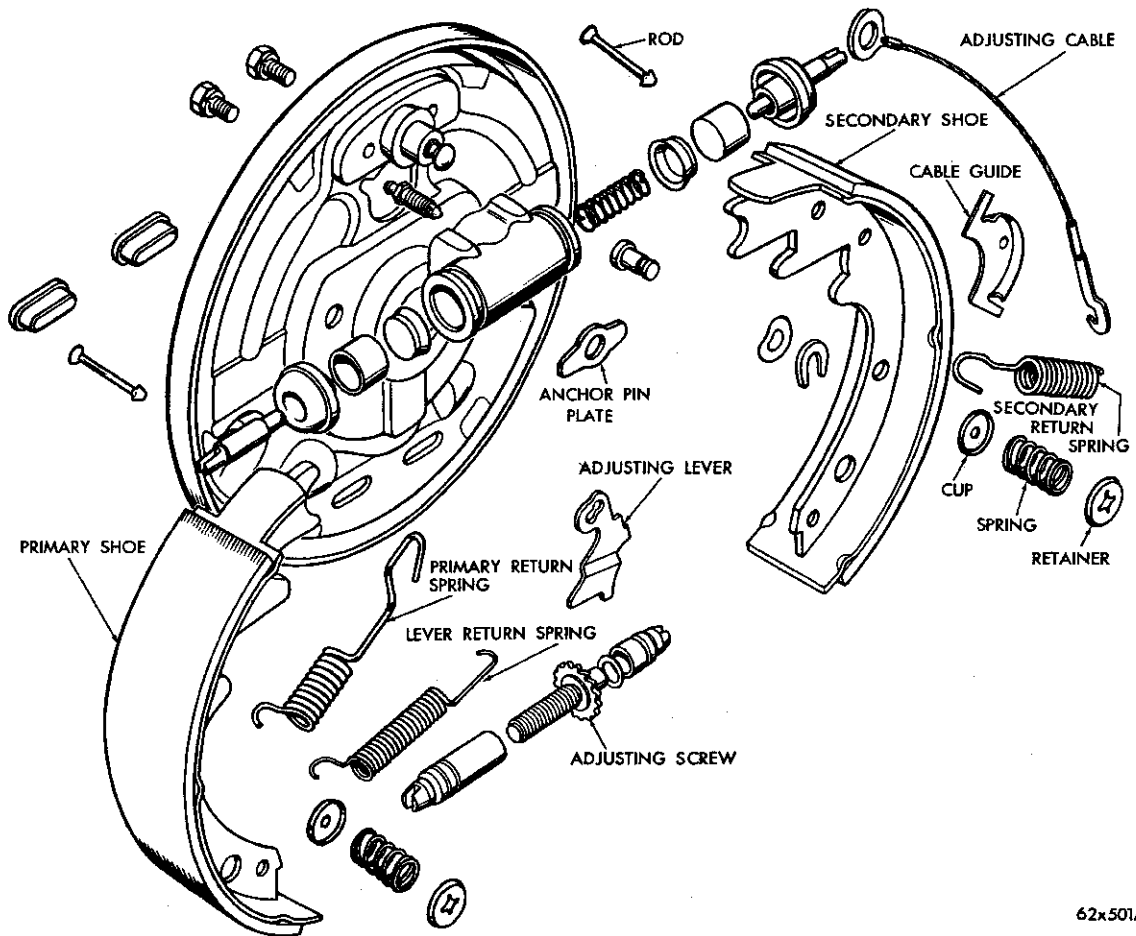

62x501A

Fig. 1—Self Adjusting Brake—Front

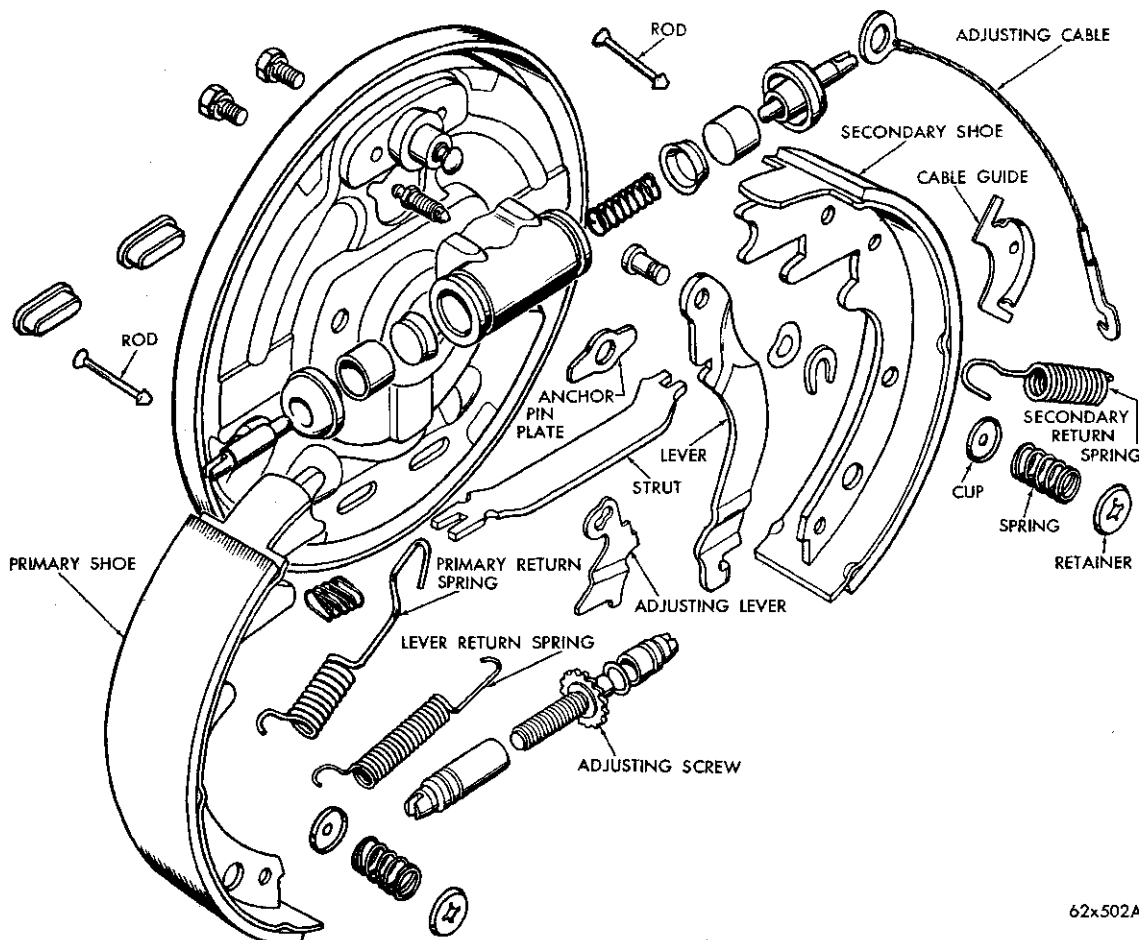

Fig. 2—Parking and Service Brake—Rear

the backing plate on the right side of the vehicle, and on the left side of the vehicle remove the front covers. (Be sure the parking brake lever is released.)

(3) Insert the adjusting wrench Tool C-3784 into the star wheel of the adjusting bolt. Move the handle of the tool downward to tighten the brake until a slight drag is felt when the wheel is rotated. Back off the adjustment 10 to 12 notches to assure clearance. This should provide a free wheel with no drag. Fill the master cylinder.

2. TESTING AUTOMATIC ADJUSTER OPERATION

Place the vehicle on a hoist, with a helper in the driver's seat to apply the brakes. Remove the plug from the rear adjustment slot in each brake support plate to observe the adjuster star wheel. Then, to exclude the possibility of maximum adjustment; that is, the adjuster refuses to operate because the closest possible adjustment has been reached; the star wheel should be backed off approximately 30 notches. It

will be necessary to hold the adjuster lever away from the star wheel to allow backing off of the adjustment.

Spin the wheel and brake drum in the reverse direction and apply the brakes vigorously. This will provide the necessary inertia to cause the secondary brake shoe to leave the anchor. The wrap up effect will move the secondary shoe and the cable will pull the adjuster lever up. Upon release of the brake pedal, the lever should snap downward, turning the star wheel. Thus, a definite rotation of the adjuster star wheel can be observed if the automatic adjuster is working properly. If by the described procedure one or more automatic adjusters do not function properly, the respective drum must be removed for adjuster servicing.

3. BRAKE DRUM REMOVAL

Removing the Front Brake Drums

To aid in the brake drum removal loosen the brake adjuster first, as shown in Figure 3.

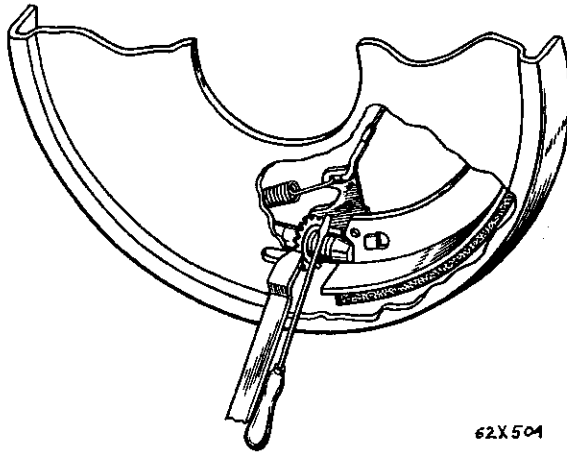

Fig. 3—Releasing the Brake Adjuster

(1) With the vehicle on a hoist, jack or suitable stands remove the rear plug from the brake adjusting access hole.

(2) Insert a thin screw driver into the brake adjusting hole and push the adjusting lever away from the star adjusting wheel.

CAUTION: Care should be taken not to bend the adjusting lever.

(3) Insert Tool C-3784 into the brake adjusting hole and engage the notches of the brake adjusting screw. Release the brake adjustment by prying up with the adjusting tool.

(4) Remove the wheel cover, grease cap, cotter pin, lock, adjusting nut, outer wheel bearing and remove the wheel and drum assembly from the spindle.

(5) Inspect the brake lining for wear, shoe alignment, or damage from grease or brake fluid.

Removing the Rear Brake Drums

(1) With the vehicle on a hoist, jack, or suitable stands, remove the rear plug from the brake adjusting access hole.

(2) Insert a thin screw driver into the brake adjusting hole and hold the adjusting lever away from the notches of the adjusting screw.

(3) Insert Tool C-3784 into the brake adjusting hole and engage the notches of the brake adjusting screw. Release the brake by prying up with the adjusting tool.

(4) Remove the wheel cover, cotter pin and axle nut.

(5) Install rear wheel hub puller Tool C-845, and remove the hub and drum assembly.

(6) Inspect the brake lining for wear, shoe alignment or damage from grease or brake fluid.

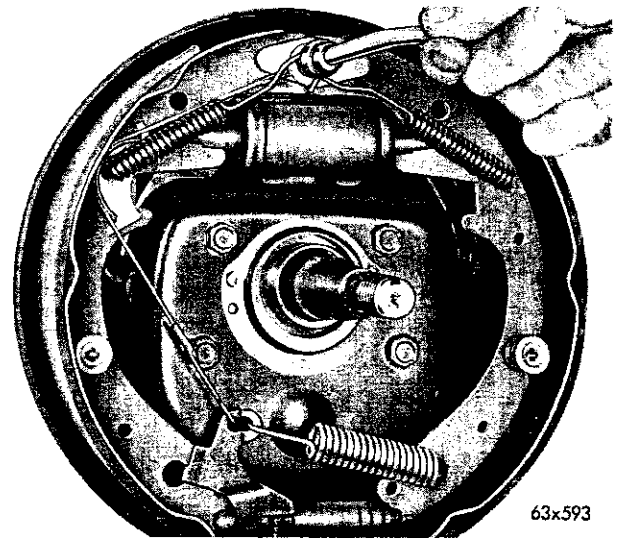

Fig. 4—Removing Brake Shoe Return Spring

4. BRAKE SHOE REMOVAL

Removing the Front Brake Shoes

With the vehicle elevated on a hoist, jack or suitable stands, remove the front wheels and drums.

(1) Using Tool C-3785 remove the brake shoe return springs, as shown in Figure 4.

(2) Remove the brake shoe retainer, spring and rods, as shown in Figure 5.

(3) Remove the anchor pin plate.

(4) Remove the primary and secondary brake shoe assembly from the backing plate.

(5) Overlap the anchor ends of the primary and

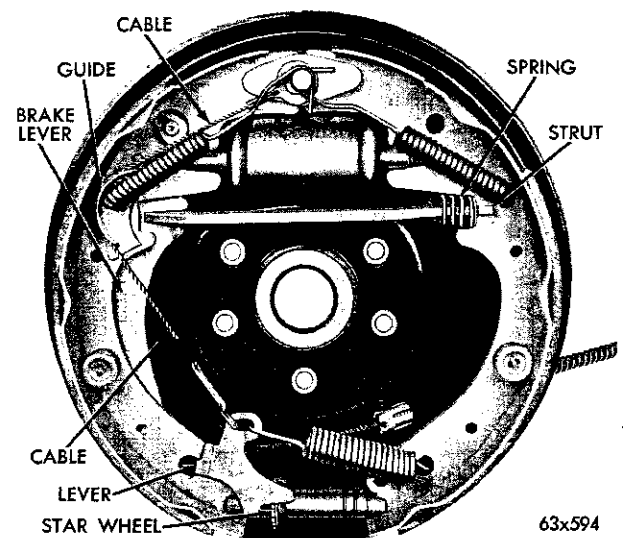

Fig. 5—Automatic Brake Adjuster Rear

secondary brake shoes and remove the adjusting screw, adjusting lever, adjusting spring, cable and cable guide.

Removing the Rear Brake Shoes

- (1) With the vehicle elevated on a hoist, jack or suitable stand use Tool C-845 and remove the hub and drum.
- (2) Using Tool C-3785 remove the brake shoe return springs, as shown in Figure 4.
- (3) Remove the brake shoe retainer, spring and rods, (Refer to Fig. 5).
- (4) Remove the anchor pin plate and tilt the brake shoe assembly out from the backing plate.
- (5) Spread the anchor ends of the primary and secondary shoes and remove the parking brake strut and spring.
- (6) Disengage the parking brake cable from the parking brake lever and remove the brake assembly.
- (7) Overlap the anchor ends of the primary and secondary shoes and remove the adjusting screw, adjusting lever, adjusting spring, cable and cable guide.

Inspecting the Brake Shoes

Wipe or brush clean (dry) the metal portions of the brake shoes. Examine the lining contact pattern to determine if the shoes are bent. The lining should show contact across the entire width, extending from heel to toe. Shoes showing contact only on one side should be replaced. Shoes having sufficient lining but lack of contact at toe and heel should be measured for proper grind.

5. GRINDING RECOMMENDATIONS

Brake Shoe Lining—New lining should be measured and ground .060 to .080 (maximum) under the drum diameter.

Drum Refacing—Measure the drum runout with an accurate gauge. Drum runout should not exceed .004 inch out of round. If the drum runout is in excess of .004 inch, the drum should be refaced. Remove only as much material as is necessary to clean up the drum. **Do not reface more than .060 inch over the standard drum diameter.**

6. BRAKE SHOE INSTALLATION

NOTE: Inspect the backing plate platform for burrs and apply a light coat of lubricant.

- (1) Match a primary with a secondary brake shoe and place them in their relative position on a work bench.
- (2) Lubricate the threads of the adjusting screw and install it between the primary and secondary shoes with the star wheel next to the secondary shoe.

(Refer to Fig. 5.) The star adjusting wheels are stamped "R" (right side) and "L" (left side), and indicate their location on the vehicle.

- (3) Overlap the anchor ends of the primary and the secondary brake shoes and install the adjusting spring and lever.
- (4) Spread the anchor ends of the brake shoes to maintain the adjusting lever and spring in position.
- (5) Holding the brake shoes in their relative position, place the brake shoe assembly on the backing plate and over the anchor pin (Fig. 6).
- (6) Install the retainer rods, cups, springs and retainers.
- (7) Install the anchor pin plate.
- (8) Install the cable guide in the secondary shoe and place the "eye" of the adjusting cable over the anchor pin.
- (9) Lubricate the groove of the cable guide and place the adjusting cable over the guide and engage the hook of the cable into the adjusting lever.
- (10) Using Tool C-3785 install the return spring into the primary shoe.
- (11) Install the secondary return spring.
- (12) Lubricate the wheel bearings and install the brake drum and adjust the wheel bearing.
- (13) Adjust the brakes.

Installing the Rear Brake Shoes

- (1) Inspect the platforms of the backing plate for nicks or burrs. Apply a thin coat of lubricant to the backing plate platforms.
- (2) Attach the parking brake lever to the back side of the secondary shoe. (Refer to Fig. 5.)
- (3) Place the secondary and a primary shoe in their relative position on a work bench.
- (4) Lubricate the threads of the adjusting screw and install it between the primary and secondary shoes with the star wheel next to the secondary shoe. The star adjusting wheels are stamped "R" (right side) and "L" (left side), and indicate their location on the vehicle.
- (5) Overlap the anchor ends of the primary and the secondary brake shoes and install the adjusting spring and lever.
- (6) Holding the brake shoes in their relative position and engage the parking brake cable into the parking brake lever.
- (7) Place the brake shoes on the backing plate and install the retainer rods, cups, springs and retainers.
- (8) Install the parking brake strut and spring between the parking brake lever and the primary shoe. (Refer to Fig. 5.)

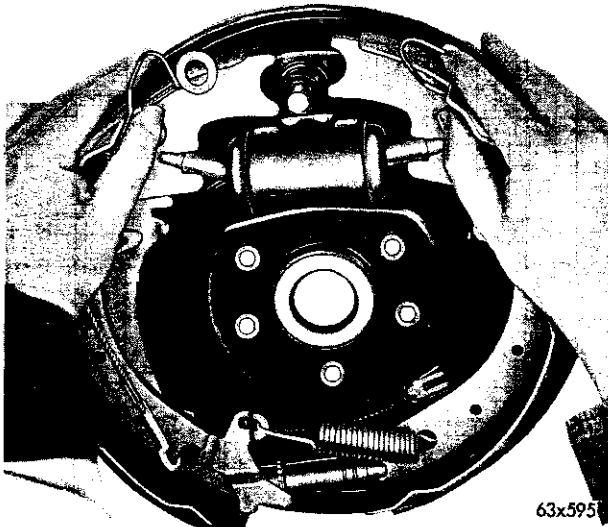

Fig. 6—Installing the Brake Assembly

- (9) Install the anchor pin plate.
- (10) Install the "eye" of the adjusting cable over the anchor pin and install the small return spring between the primary shoe and the anchor pin.
- (11) Lubricate the groove of the cable guide and install it in the secondary shoe then install the secondary return spring.

(12) Place the adjusting cable in the groove of the cable guide and engage the hook of the cable into the adjusting lever.

(13) Install the brake drum and torque the axle nut to 145 foot-pounds torque.

(14) Adjust the brakes.

7. BLEEDING THE BRAKE SYSTEM

Clean all dirt and foreign material from the cover of the master cylinder to prevent any dirt from falling into the master cylinder reservoir when the cover is removed.

Using Automatic refiller Tool C-8378 (with adaptor C-3494A) or the one man bleeder tank C-3496 (with adaptor C-3494A) provides a convenient means of keeping the master cylinder full while bleeding the hydraulic system.

NOTE: The brakes may also be bled manually by having an assistant slowly pump the brake pedal while the brakes are being bled. Be certain to refill the master cylinder after bleeding each wheel.

Tighten the brakes of each wheel until the brakes are locked. (This reduces the movement of the wheel cylinder cups and assists in bleeding.)

Starting with the right rear wheel clean all dirt from the bleeder valve. Place bleeder hose C-650 on the bleeder valve and insert the other end of the

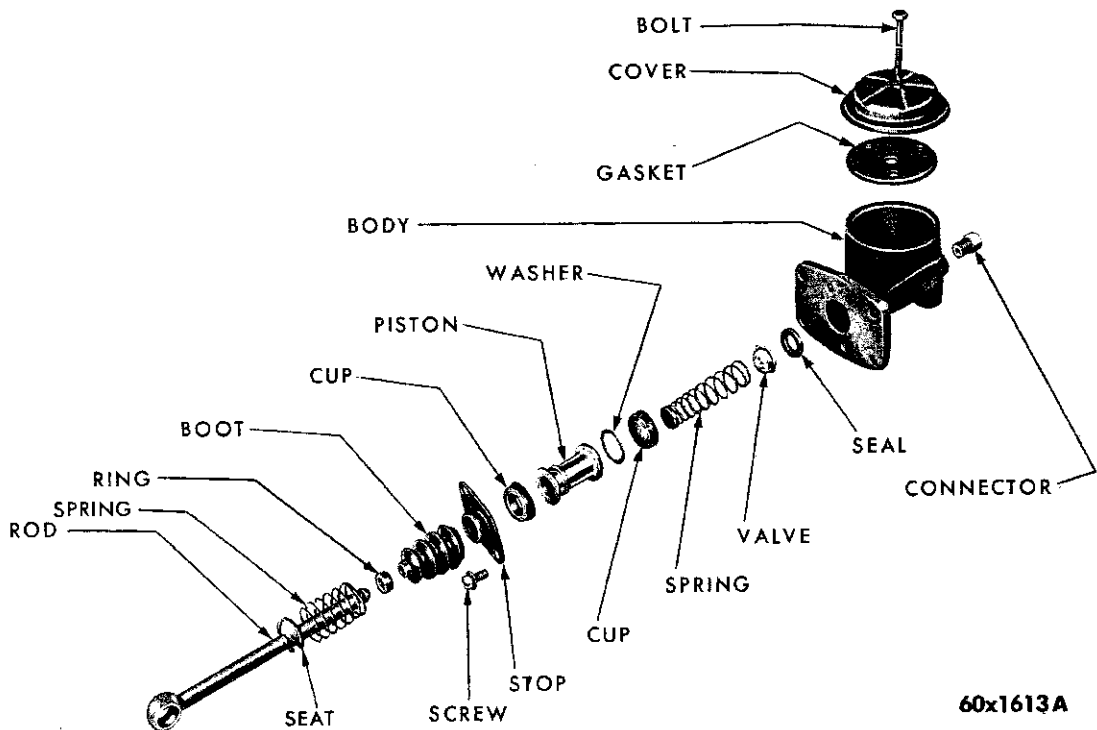

Fig. 7—Master Cylinder Assembly

60x1613A

bleeder hose into a clean jar half filled with brake fluid. (This will permit the observation of air bubbles as they are being expelled from the hydraulic system and also prevent air from being drawn back into the system as the brake pedal is released on manual bleeding.) Follow the manufacturers instructions in the use of the bleeder tools.

When manually bleeding the hydraulic system, push the brake pedal down and let it return slowly, to avoid air being drawn into the system. Bleed intermittently by opening and closing the valve about every four seconds. This causes a swirling action in the cylinder and assists in expelling the air. Continue the action until the brake fluid is expelled in a solid stream, without any bubbles.

Continue this bleeding operation on the other wheels, starting with the left rear wheel, then the right front and finishing with the left front wheel.

If necessary, repeat this bleeding operation if there is any indication (a low, soft or spongy brake pedal) of air remaining in the hydraulic system. Readjust the brakes.

8. MASTER CYLINDER

Disassembly (Fig. 7)

- (1) Remove the pedal return spring.
- (2) Disconnect the push rod.
- (3) Disconnect the brake tube at the master cylinder.
- (4) Remove the nuts and bolts that attach the master cylinder to the dash panel. Slide the master cylinder straight out and away from the dash panel.
- Clean the outside of the master cylinder thoroughly, then remove the cover and drain all the brake fluid. Refer to Figure 7 and disassemble the master cylinder for inspection as follows:
 - (5) Remove the piston stop flange attaching screws and remove the dust boot, push rod and piston assembly. (Do not remove the push rod from the piston.)
 - (6) Remove the brass washer between the piston and the cup. Remove the master cylinder cup, spring and valve from the master cylinder.
 - (7) Wash the master cylinder in a suitable solvent and inspect for a scored or pitted cylinder.

If the master cylinder piston is badly scored or corroded, replace it with a new one. The piston cups and valve assembly should be replaced when reconditioning the master cylinder.

Master cylinder walls that have light scratches or show signs of corrosion, can usually be cleaned up with crocus cloth. However, cylinders that have deep scratches or scoring may be honed, providing the diameter of the cylinder bore is not increased more than .002 inch. A master cylinder bore that

does not clean up at .002 inch should be discarded and a new cylinder installed. (Black stains on the cylinder wall are caused by the piston cups and will do no harm.)

CAUTION: Use extreme care in cleaning the master cylinder after reconditioning. Remove all dust or grit by flushing the cylinder with alcohol; wipe dry with a clean lintless cloth and clean a second time with alcohol. Dry the master cylinder with air pressure, then flush with clean brake fluid. (Be sure the compensator port in the master cylinder bore is open.)

Assembly

Before assembling, the piston, cups and valve assembly should be dipped in new MoPar brake fluid.

- (1) Install the check valve and spring in the cylinder with the valve toward the outlet of the cylinder (Fig. 7).
- (2) Install the master cylinder cup in the cylinder with the open end of the cup over the closed end of the return spring.
- (3) Install the secondary cup on the master cylinder piston and install the piston and push rod assembly in the cylinder with the flat brass washer between the piston and the cup.
- (4) Install the dust boot on the push rod and install the stop flange screws.
- (5) Reinstall the master cylinder on the firewall and fill with MoPar brake fluid.
- (6) Attach the brake line.
- (7) Bleed the brake system.

9. WHEEL CYLINDERS

Disassembly

- (1) With all the brake drums removed inspect the wheel cylinder boots for evidence of a brake fluid leak. (A slight amount of fluid on the boot may not be a leak, but may be preservative oil used on the assembly.)
- (2) In the case of a leak, remove the brake shoes (replace if soaked with grease or brake fluid), boots, piston wheel cylinder cups and wheel cylinder cup expansion spring.
- (3) Wash the cylinder with alcohol and inspect the cylinder for scores or pits.

Wheel cylinder pistons that are badly scored or corroded should be replaced. The old piston cups should be discarded when reconditioning the hydraulic system.

Cylinder walls that have light scratches, or show signs of corrosion, can usually be cleaned up with crocus cloth, using a circular motion. However, cyl-

5-8 BRAKES

inders that have deep scratches or scoring may be honed, using Tool C-3080, providing the diameter of the cylinder bore is not increased more than .002 inch. A cylinder that does not clean up at .002 inch should be discarded and a new cylinder installed. (Black stains on the cylinder walls are caused by the piston cups and will do no harm.)

Assembly

Before assembling the pistons and new cups in the wheel cylinder, dip them in MoPar brake fluid. Refer to Figure 8, then assemble the brake cylinders. If the boots are deteriorated, or do not fit tightly on the brake shoe pin, as well as the wheel cylinder casting, new boots should be installed.

(1) Wash the wheel cylinder with alcohol and blow dry with air.

(2) Install the expansion spring in the cylinder. Install the wheel cylinder cups in each end of the cylinder with the open end of the cups facing each other.

(3) Install the wheel cylinder pistons in each end of the cylinder with the recessed end of the pistons facing the open ends of the cylinder.

(4) Install the boots over the ends of the cylinder. Keep the assembly compressed with the aid of a brake cylinder clamp until the brake shoes are assembled.

10. BRAKE SUPPORT PLATE

Removal (Front)

(1) With the wheel and brake drum removed, remove the four support plate attaching nuts and washers.

(2) Disconnect the brake line from the brake hose.

(3) Remove the support plate and brake assembly from the spindle.

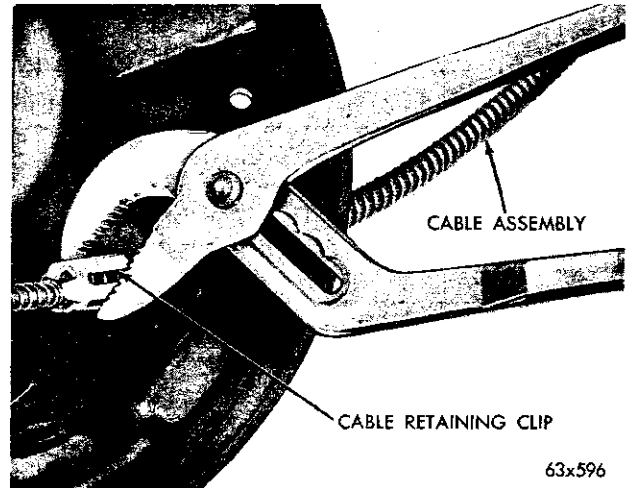

Fig. 9—Removing Rear Cable from Support Plate

Removal (Rear)

(1) With the wheel and brake drum removed, remove the four backing plate attaching nuts and washers.

(2) Remove the rear axle shaft and retainer.

(3) Disconnect the hydraulic brake line from the wheel cylinder.

(4) Disengage the brake cable from the parking brake lever.

(5) Using a suitable tool compress the three flared legs of the cable retainer and pull the brake cable out of the support plate (Fig. 9).

(6) Remove the brake support plate from the rear axle housing.

Installation (Front)

(1) With the brake shoes installed on the support

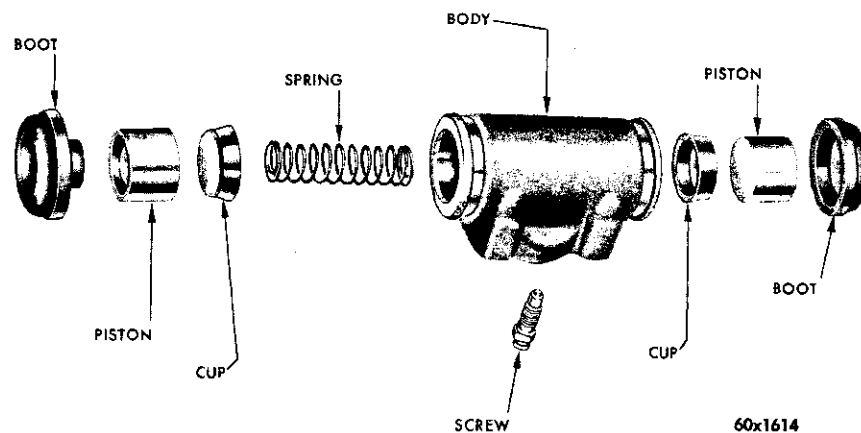

Fig. 8—Wheel Cylinder Assembly

plate, apply a small amount of a putty type sealing material around the back side of all holes and openings of the support plate to prevent any water or dirt from entering the brake assembly.

(2) Place the support plate on the spindle support and install the attaching bolts, nuts and washers. Tighten the attaching nuts to 35 foot-pounds torque.

(3) Attach the brake line to the wheel cylinder and tighten to 95 inch-pounds torque.

(4) Install the brake drum and wheel bearings. Adjust the bearings. Bleed and adjust the brakes.

Installation (Rear)

(1) With the brake shoes installed on the support plate, apply a small amount of putty type sealing material around the back side of all the holes and openings of the support plate to prevent any water or dirt from entering the brake assembly.

(2) Install the support plate onto the rear axle housing.

(3) Insert the rear axle shaft and retainer into the housing and install the axle retainer nuts and washers. Tighten the retainer nuts to 35 foot-pounds torque.

(4) Attach the brake line to the wheel cylinder and tighten to 95 inch-pounds torque.

(5) Insert the parking brake cable into the support plate and attach the cable to the parking brake lever.

(6) Install the brake drum and wheel. Bleed and adjust the brakes.

11. WHEEL STUD TIGHTENING

NOTE: The tightening sequence and torquing of the wheel stud nuts is of great importance to insure efficient brake operation. The use of an impact or long handled wrench may distort the drum.

A criss-cross tightening sequence should be used,

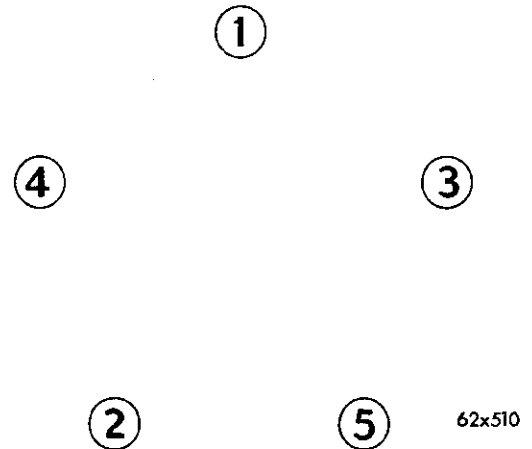

Fig. 10—Wheel Stud Nut Tightening

(Fig. 10). Tighten all the stud nuts to one-half the specified torque first, (30 ft. lbs.) and then repeat the sequence tightening to the specified 55 foot-pounds torque.

12. TEST FOR FLUID CONTAMINATION

To determine if contamination exists in the brake fluid, (as indicated by swollen or deteriorated rubber cups) the following tests can be made.

(1) Place a small amount of the drained brake fluid into a small clear glass bottle. Separation of the fluid into distinct layers will indicate mineral oil content.

(2) Add water to the contents and shake. If the contents become milky, oil is present. If the contents remain clear, it is not contaminated with mineral oil.

NOTE: Be safe and discard old brake fluid that has been bled from the system. Fluid drained from the bleeding operation may contain dirt particles or other contamination and should not be reused.

PARKING BRAKES

Parking Brakes (Chrysler)

The rear wheel service brakes also act as parking brakes. The brake shoes are mechanically operated by a lever and strut connected to a flexible steel cable. The wheel brake cables are joined together by a center cable which in turn is connected to a forward brake cable extending to the parking brake pedal and release handle.

Parking Brakes (Imperial)

The parking brake pedal assembly used on Imperial Models only, is pedal applied as previous but

is now released by a vacuum chamber. When the engine is started and vacuum is developed, energy is then available to release the parking brake. This is controlled by the transmission push buttons. When the transmission is in the neutral position the neutral button slide closes a valve mounted on the rear of the push button box, this stops the vacuum to the vacuum release chamber and there is no action of the parking brake pedal. When one of the drive buttons (forward or reverse) is depressed, the neutral button and slide are released permitting the vacuum control valve to open and actuate the vacuum re-

5-10 BRAKES

lease chamber. In the event of engine failure and no vacuum, the brake may be released by a manual release lever mounted on the left side of the parking brake pedal assembly. This assembly prevents the vehicle from being driven with the parking brake in the applied position.

13. PARKING BRAKE ADJUSTMENT

(1) Release the parking brake foot lever, loosen the cable adjusting nut to ensure the cable is slack then correctly adjust the rear wheel brakes.

(2) In the case of newly installed cables, connect the cable system then pull down firmly on the unshrouded cable to seat the cable fittings in their brackets.

(3) Tighten the cable adjusting nut until the rear wheels are difficult to turn then slacken the cable adjusting nut until both wheels can be rotated freely without dragging brakes.

(4) Apply the parking brake several times, then release and test to see that the rear wheels rotate freely without dragging.

14. PARKING BRAKE CABLE (REAR)

Removal (Imperial)

The independent brake cables are attached to an equalizing cable by "C" type brackets, as shown in Figure 11. The cable is adjusted at the spreader clamp at the center of the equalizing cable.

Should it become necessary to remove the parking brake cable (rear), for installation of a new cable, refer to Figure 11.

(1) With the vehicle jacked up or on a suitable hoist, remove the rear wheels.

(2) Remove the brake drum from the rear axle.

(3) Remove the brake shoe return springs.

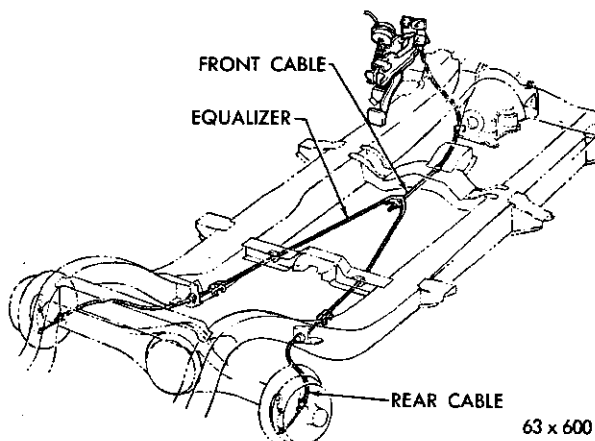

Fig. 11—Parking Brake Cable Routing (Imperial)

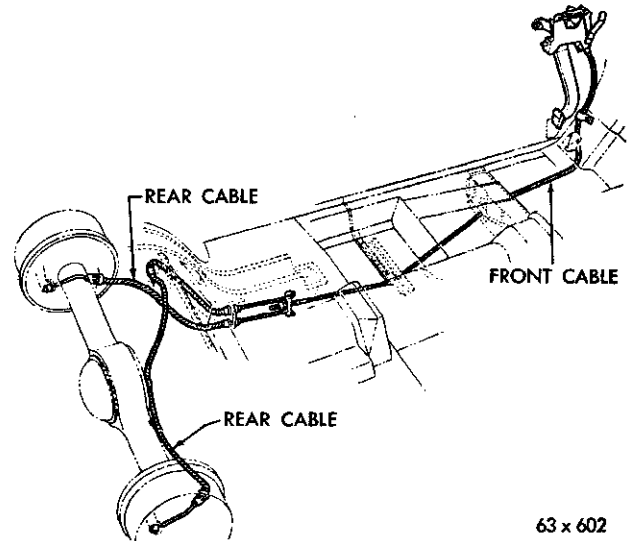

Fig. 12—Parking Brake Cable Routing (Chrysler)

(4) Remove the brake shoe retaining springs.

(5) Remove the brake shoes strut and spring from the brake back plate and disconnect the brake cable from the operating arm.

(6) Compress the retainers on the end of the brake cable housing and remove the cable from the brake plate (Fig. 9).

(7) Disconnect the brake cable from the "C" clamp.

(8) Remove the retaining clip from the brake cable bracket and remove the cable assembly.

Removal (Chrysler)

The independent brake cables are attached to an equalizer, as shown in Figure 12. The front cable is adjusted at the equalizer.

Should it become necessary to remove the parking brake cable (rear) for installation of a new cable, refer to Figure 12.

(1) With the vehicle jacked up or on a suitable hoist, remove the rear wheels.

(2) Remove the brake drum from the rear axle.

(3) Remove the brake shoe return springs.

(4) Remove the brake shoe retaining springs.

(5) Remove the brake shoes strut and spring from the brake back plate and disconnect the brake cable from the operating arm.

(6) Compress the retainers on the end of the brake cable housing and remove the cable from the brake plate (Fig. 9).

(7) Remove the retaining clip from the brake cable bracket.

(8) Disconnect the brake cable from the equalizer.

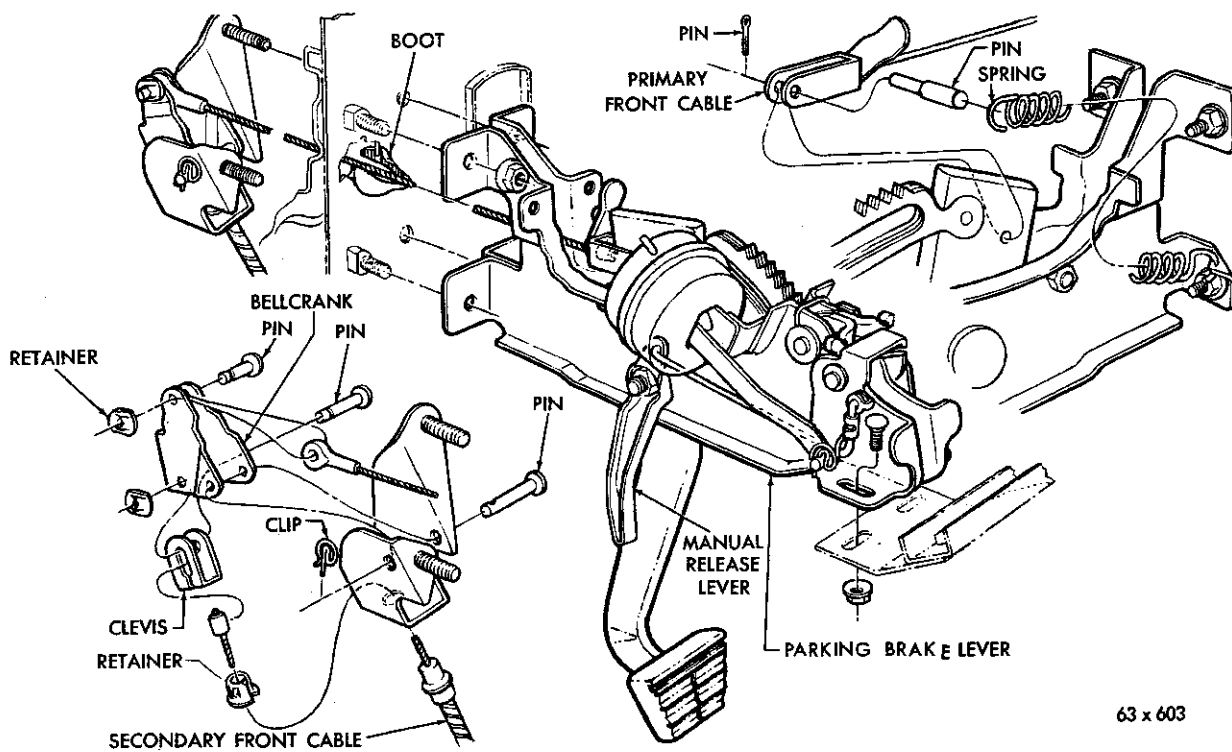

63 x 603

Fig. 13—Parking Brake Pedal (Imperial)

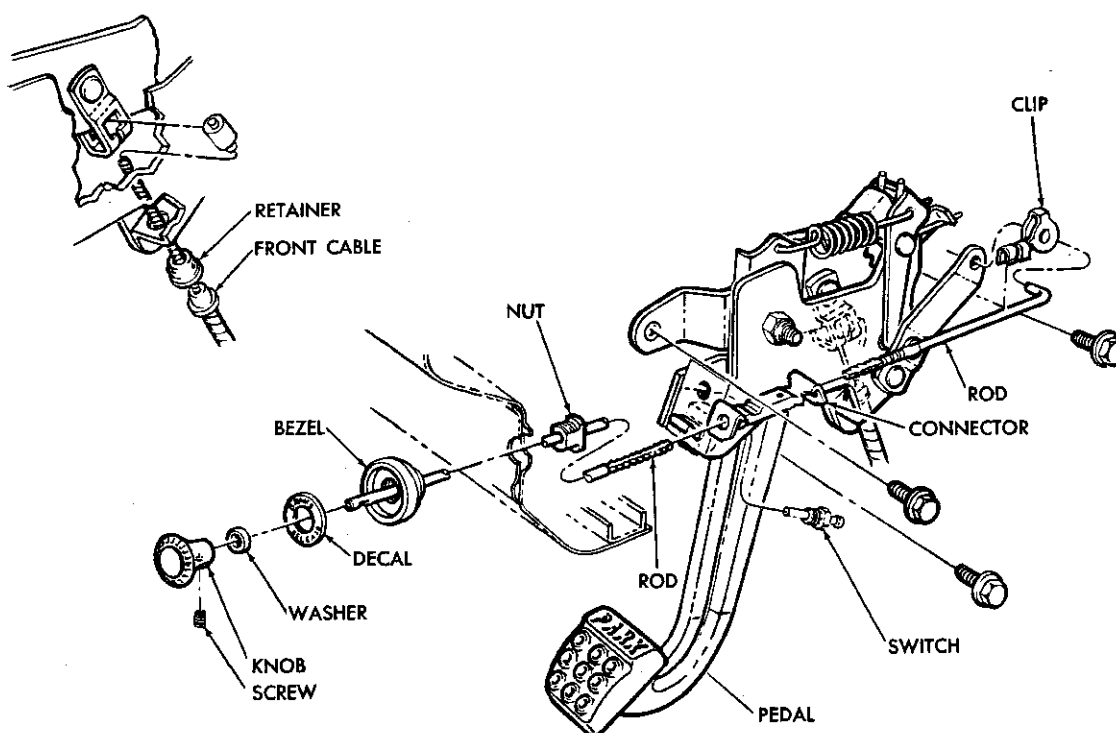

63 x 604

Fig. 14—Parking Brake Pedal (Chrysler)

Installation (Imperial)

NOTE: When installing a new brake cable, lubricate the cable with short fibre grease at the contact points.

- (1) Insert the brake cable and the housing into the cable bracket and install the retaining cup.
- (2) Insert the brake cable and housing into the brake support plate, making certain that the housing retainers lock the housing firmly into place.
- (3) Holding the assembled brake shoes in place on the support plate, engage the brake cable into the brake shoe operating lever.
- (4) Install the brake shoe retaining springs and the brake shoe return springs.
- (5) Insert the front end of the brake cable into the "C" clamp of the equalizer cable.
- (6) Install the brake drum and the wheel.
- (7) Adjust the service brakes and the parking brake cable.

Installation (Chrysler)

NOTE: When installing a new brake cable, lubricate the cable with short fibre grease at the contact points.

- (1) Insert the brake cable and the housing into the cable bracket and install the retaining clip.
- (2) Insert the brake cable and housing into the brake support plate making certain that the housing retainers lock the housing firmly into place.
- (3) Holding the brake shoes in place on the support plate, engage the brake cable into the brake shoe operating lever.
- (4) Install the brake shoe retaining springs, and the brake shoe return springs.
- (5) Insert the front of the brake cable into the equalizer.
- (6) Install the brake drum and the wheel.
- (7) Adjust the service brakes and the parking brake cable.

15. PARKING BRAKE CABLE (FRONT)**Removal (Imperial)**

- (1) Disengage the front cable from the equalizer and using a screw driver force the cable housing and attaching clip out of the frame crossmember.
- (2) Refer to Figure 13 and remove the bellcrank clip, pivot pin, and remove the clevis and cable from the mounting bracket.
- (3) Remove the clevis pin and work the cable up and out of the clevis.
- (4) Disengage the parking brake cable and housing from the anchoring bracket at the transmission and remove the cable assembly from the vehicle.

Removal (Chrysler)

- (1) Disengage the front parking brake cable from the equalizer bar (Fig. 14).
- (2) Disengage the cable and housing from the guide clip.
- (3) Using a screw driver force the cable housing and attaching clip out of the body crossmember.
- (4) Fold back the left front edge of the floor mat and remove the rubber cable cover from the floor pan.
- (5) Depress the parking brake pedal and work the brake cable up and out of the brake pedal linkage.
- (6) Using a screw driver force the upper end of the cable housing and clip down out of the pedal assembly bracket.
- (7) Remove the cable to the floor pan clip and work the cable and housing assembly up through the floor pan.

Installation (Imperial)

- (1) In the engine compartment side, engage the cable and housing assembly up into the bellcrank mounting bracket (Fig. 13).
- (2) Engage the cable end into the bellcrank clevis and install the bellcrank and clevis into the mounting bracket. Install the clevis pin and clip.
- (3) Attach the cable and housing assembly into the support clamp at the transmission.
- (4) Insert the cable through the attaching hole of the body crossmember and force the clip and housing firmly into place.
- (5) Attach the front cable to the equalizer cable.
- (6) Adjust the service brakes and parking brake cable.
- (7) Test the operation of the vacuum release valve (Fig. 15).

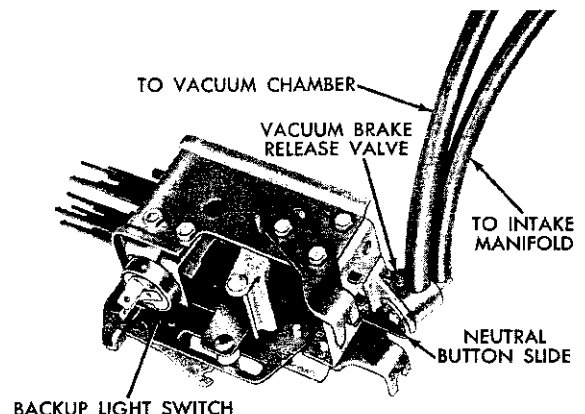

63x597

Fig. 15—Vacuum Brake Release Valve

(8) Apply the brakes several times and test for free wheel rotation when the brake pedal is in the "off" position.

Installation (Chrysler)

(1) Insert the rear end of the brake cable and housing down through the cable routing hole in the floor pan.

(2) Engage the upper end of the cable and housing assembly up through the pedal assembly bracket and firmly attach the housing and clip into the bracket.

(3) Depress the parking brake pedal and insert the end of the cable into the parking brake pedal clevis.

(4) Insert the cable through the body crossmember and firmly press into place the housing and attaching clip.

(5) Attach the front cable to the equalizer bar.

(6) Adjust the service brakes and parking brake cable.

(7) Apply the brakes several times and test for free wheel rotation when the parking brake is in the "off" position.

BENDIX SINGLE DIAPHRAGM BOOSTER BRAKE

The Bendix single diaphragm booster brake is of the vacuum suspended type and does not require a reserve vacuum tank. This booster utilizes engine manifold vacuum and atmospheric pressure for its power. It is composed of three basic elements to compose a single power unit. The three units are:

(1) A vacuum power section which is composed of a front and rear housing, a power diaphragm, a return spring and a push rod (Fig. 15A).

(2) A control valve built integral with the power diaphragm and connected through a valve rod to the brake pedal and controls the degree of brake application or release in accordance with the pressure applied to the brake pedal.

(3) A master cylinder attached to the vacuum power section contains all the conventional elements except the push rod which is a part of the brake booster.

SERVICE PROCEDURES

16. BOOSTER BRAKE

Removal

(1) From within the engine compartment disconnect the brake line from the master cylinder.

(2) Remove the vacuum hose from the booster.

(3) From under the dash, remove the brake pedal and push rod attaching bolt and nut.

(4) Remove the four booster-to-dash attaching nuts and remove the booster assembly from the vehicle.

(5) Place the booster assembly on a clean service bench for disassembly.

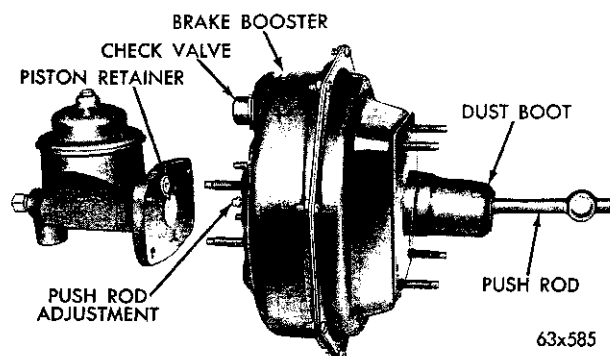

Fig. 15A—Brake Booster and Master Cylinder

Disassembly

(1) Remove the four master cylinder attaching nuts and remove the master cylinder from the booster.

(2) Remove the dust boot from the back of the booster housing.

(3) Pry off the retaining ring on the back of the booster and remove the air filter and silencers (Fig. 16).

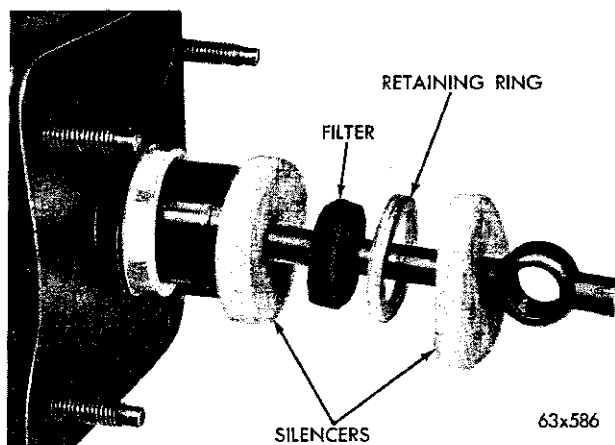

Fig. 16—Air Filter and Silencers

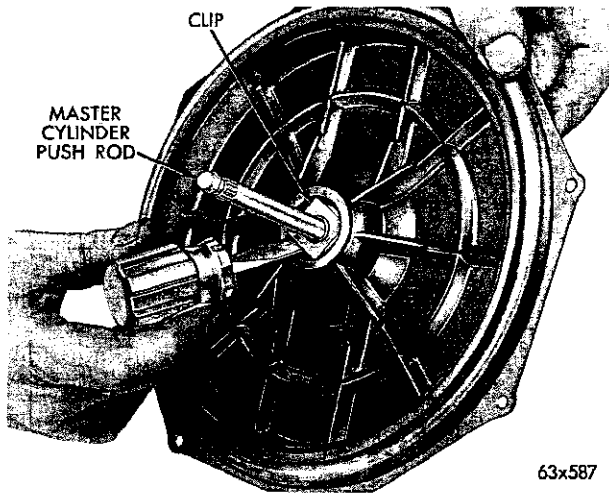

Fig. 17—Removing Push Rod Retainer

(4) Place the booster assembly in a vise and remove the eight front and rear housing attaching screws.

CAUTION: The diaphragm is spring loaded and care should be taken to prevent the front and rear shells from flying apart.

(5) Holding the two shells together, remove the booster from the vise and carefully separate the two shells.

(6) Remove the return spring.

(7) Remove the master cylinder push rod retainer (Fig. 17).

(8) Remove the diaphragm and valve assembly from the rear shell.

(9) Place the diaphragm and valve housing face down and stretch the rubber diaphragm out and over the hub of the valve body (Fig. 18).

(10) Holding the valve housing in a vertical posi-

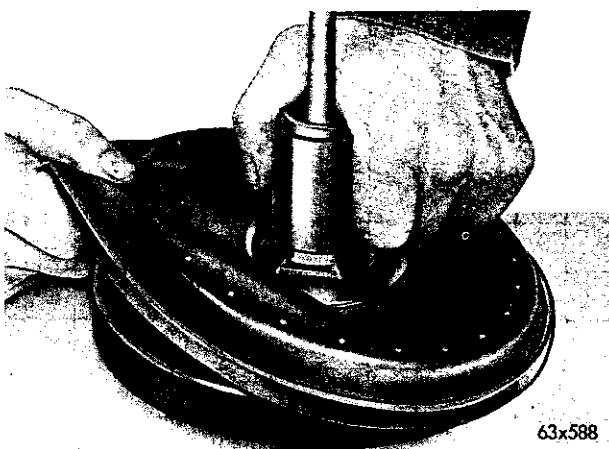

Fig. 18—Removing Rubber Diaphragm

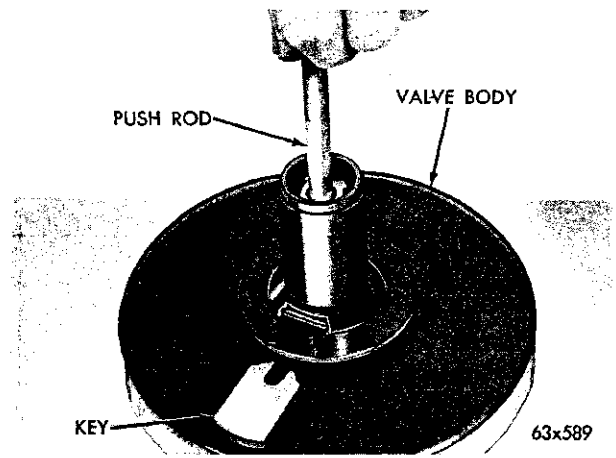

Fig. 19—Removing Push Rod Lock

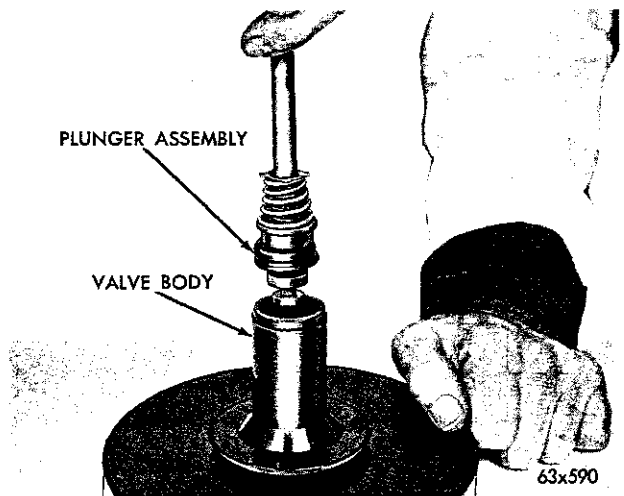

Fig. 20—Removing or Installing Rod and Valve

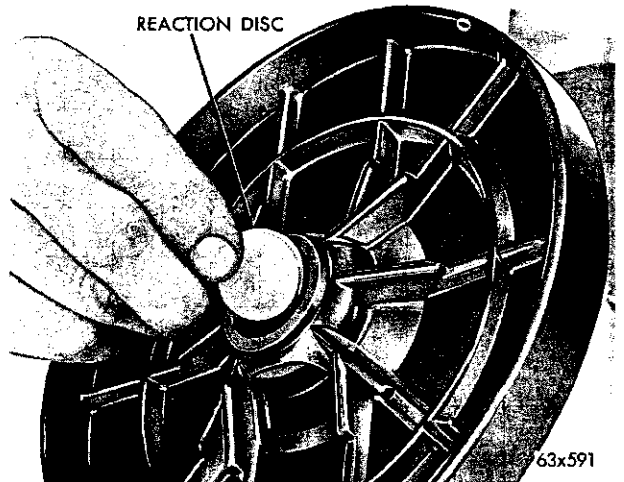

Fig. 21—Removing or Installing Reaction Disc

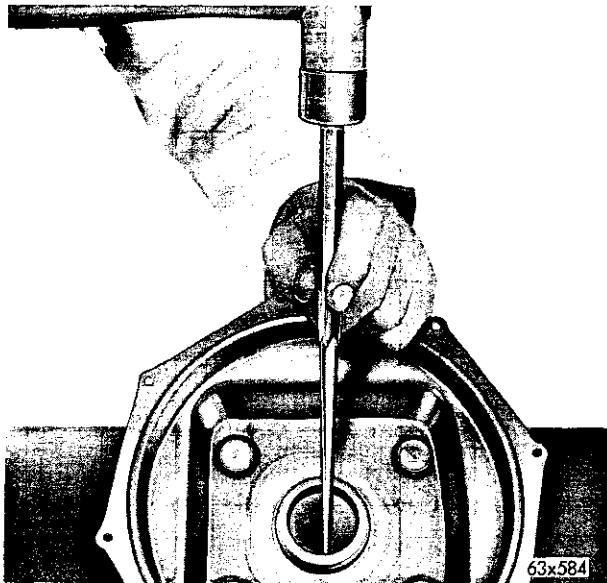

Fig. 22—Removing Rear Seal

tion, press in on the push rod and permit the lock to disengage from the push rod and the valve assembly (Fig. 19).

(11) Holding the diaphragm housing, remove the rod and valve assembly (Fig. 20). Remove the rubber valve poppet from the rod.

(12) Press out the reaction disc from the diaphragm plate (Fig. 21).

(13) Support the rear shell on two wooden blocks and drive out the rear seal (Fig. 22).

(14) Using a thin screw driver, pry out the front seal retainer and remove the front seal (Fig. 23).

(15) Thoroughly clean all parts with mineral spirits or alcohol. Recondition or replace as necessary.

Inspection

Inspect all parts for excessive wear. Replace any damaged or worn parts. Inspect the master cylinder bore for scoring, rust, pitting or etching. Recondition or replace as necessary.

Assembly

(1) Press a new seal into the rear housing until the seal is flush with the housing.

(2) Install the front seal and retainer.

(3) Install the reaction disc into the diaphragm plate.

(4) Install the valve poppet and the rod and valve assembly.

(5) With the valve housing supported on a flat horizontal surface, press down on the plunger rod and

insert the lock into the housing and valve assembly.

(6) Dip the diaphragm in mineral spirits and install it on the plate and valve body.

(7) Install the diaphragm and valve body into the rear housing (Fig. 20).

(8) Install the master cylinder push rod and retainer.

(9) Supporting the rear housing on blocks or a vise, install the return spring with the small end toward the front of the booster assembly.

(10) Place the front housing on the return spring and compress the spring (guiding the master cylinder push rod through the front seal).

(11) Align the scribe marks and install the housing attaching screws finger tight and then progressively tighten.

(12) Install the air filter, silencer and retaining ring.

(13) Install the master cylinder on the brake booster assembly and tighten the attaching nuts.

Installation

(1) Insert the booster push rod through the mounting hole of the dash panel and attach the booster assembly. Tighten attaching nuts.

(2) Install the dust boot over the plunger and insert the spacer washer between the plunger and the brake pedal.

(3) Install the plunger and pedal attaching bolt and nut.

(4) Install the vacuum hose to the booster assembly.

(5) Fill and bleed the master cylinder, then attach the brake line.

(6) Bleed the hydraulic system, start the engine and test the booster for operation.

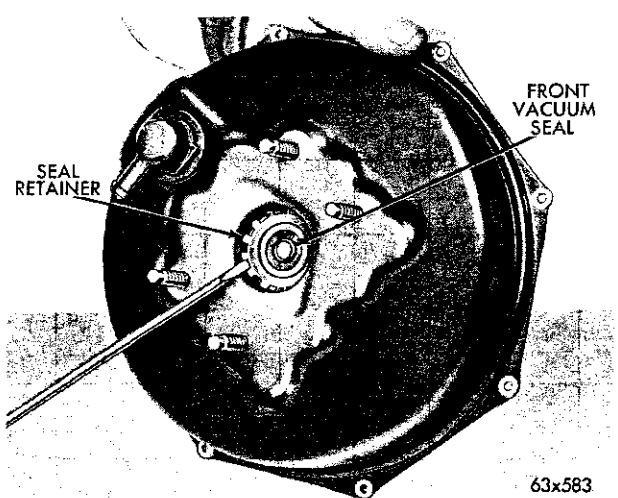

Fig. 23—Removing Front Seal and Retainer

MIDLAND ROSS POWER BOOSTER BRAKE

The Midland Ross power booster brake (Fig. 24) is located on the engine side of the dash panel. The forward portion of the vacuum cylinder is die-cast and supports the master cylinder. The power booster de-

rives its power from the intake manifold vacuum and atmospheric pressure. It does not require a vacuum reservoir.

SERVICE PROCEDURES

17. BOOSTER BRAKE

Removal

(1) With the engine turned off, apply the brakes several times to balance the internal pressure of the brake booster.

(2) Disconnect the hydraulic brake line from the master cylinder.

(3) Disconnect the vacuum hose from the vacuum booster.

(4) From under the dash, remove the nut and attaching bolt from the plunger and brake pedal linkage.

(5) Remove the four booster attaching nuts and washers.

(6) Remove the booster and master cylinder from the vehicle.

Disassembly

(1) Remove the four master cylinder attaching nuts and remove the master cylinder.

(2) Scribe an aligning mark across the joint of the front and rear portions of the booster assembly. This will insure correct alignment during reassembly.

(3) Remove the dust boot from the operating rod.

(4) Remove the two filter cover retaining screws.

(5) Remove the filter cover and filter.

(6) Working from the front of the unit, push the outer lip of the bellows assembly into the vacuum chamber (Fig. 25).

(7) Remove the ten front and rear housing attaching screws.

(8) Using a plastic or rubber hammer tap the outside edge of the rear vacuum housing and separate the housings.

(9) Remove the large snap ring from the rear seal retainer, (Fig. 26) and remove the diaphragm, valve housing assembly and rear seal from the rear housing.

(10) Using a screw driver pry out the large retain-

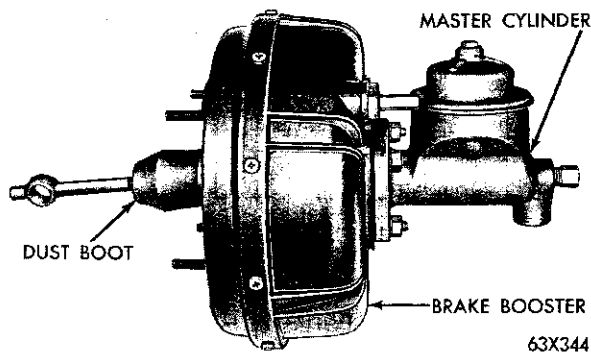

Fig. 24—Brake Booster and Master Cylinder

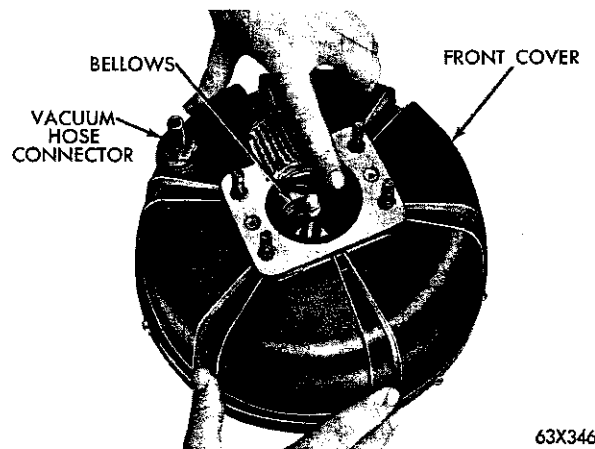

Fig. 25—Unseating the Bellows Seal

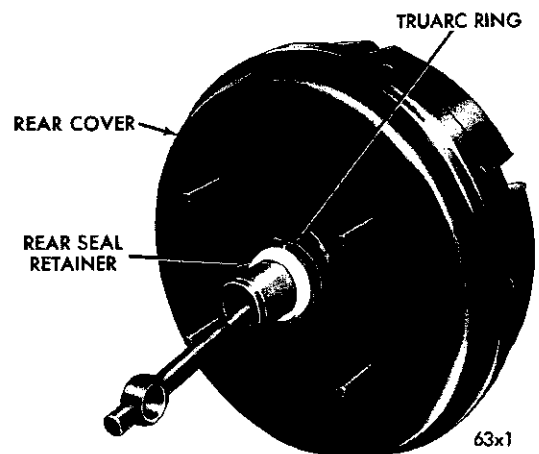

Fig. 26—Rear Seal Retainer

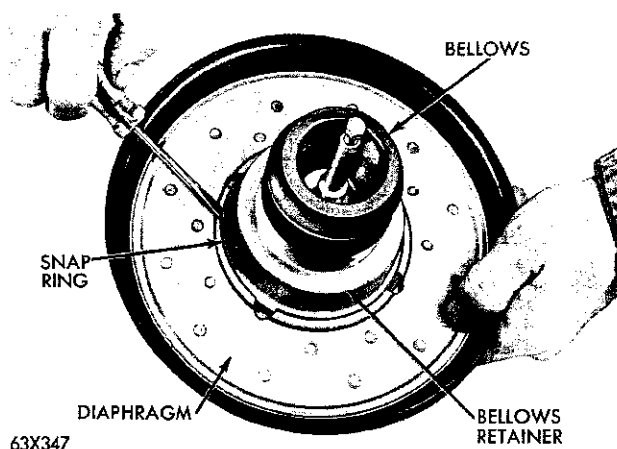

Fig. 27—Removing Bellows Retainer

ing snap ring that retains the bellows to the diaphragm (Fig. 27).

(11) Pull the bellows out of the retainer and remove the retaining ring from the bellows.

(12) Slide the master cylinder push rod off of the plunger (Fig. 28).

(13) Remove the reaction lever and retainer assembly from the valve body and remove the levers from the retainer (Fig. 29).

(14) Remove the two plastic rings from the plunger shaft.

(15) Remove the retaining clip (Fig. 30) from the plunger shaft and remove the load ring and valve (Fig. 31).

(16) Remove the plunger from the valve body.

(17) Remove the rear seal retainer from the plunger.

NOTE: The plunger assembly will be serviced as a unit and need not be dismantled further.

(18) Using a small screw driver remove the rear seal from the rear seal retainer. Remove the "O"

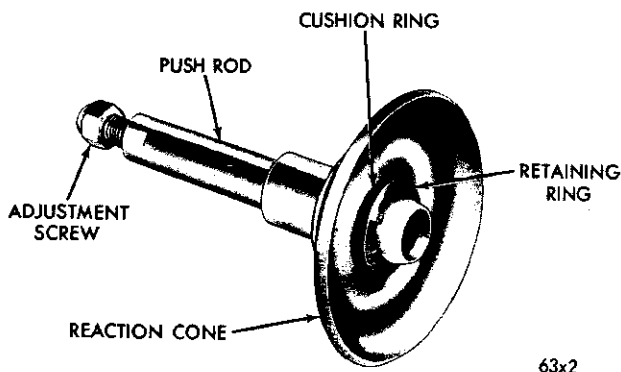

Fig. 28—Master Cylinder Push Rod

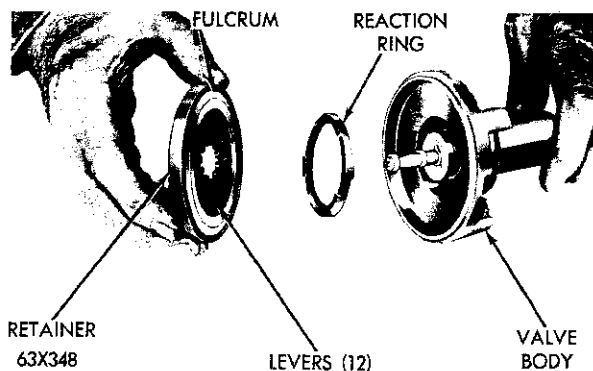

Fig. 29—Valve Body and Reaction Levers

ring from the outer diameter of the seal retainer (Fig. 32).

(19) Remove the two "O" rings, seal and cushion ring from the valve plunger (Fig. 33).

(20) Remove the "O" ring from the outside diameter of the valve body.

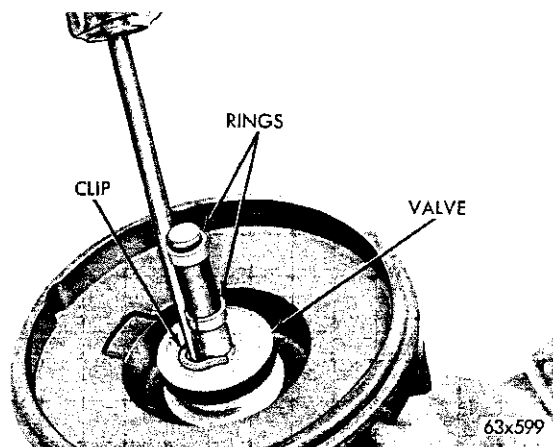

Fig. 30—Removing Valve Retainer

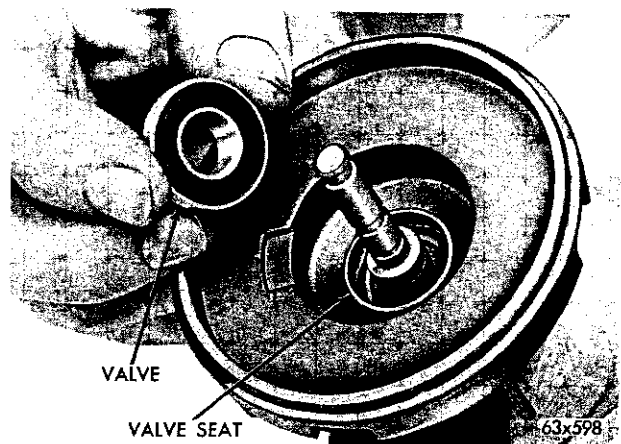

Fig. 31—Removing or Installing the Valve

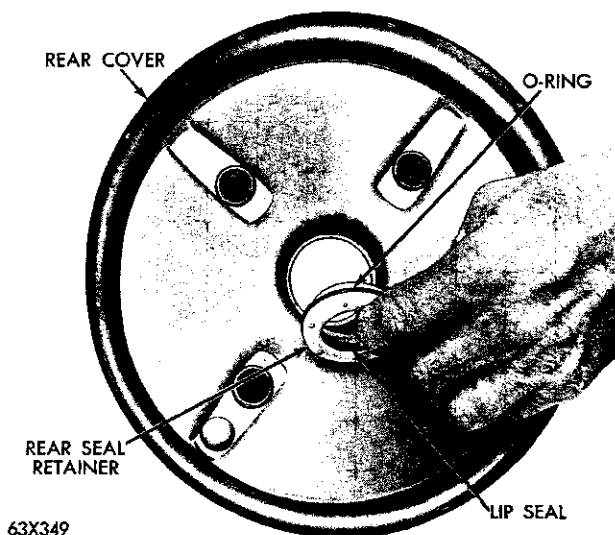

Fig. 32—Rear Seal Assembly

Assembly

Wash all rubber parts in mineral spirits and air dry.

- (1) Install the "O" ring on the outside diameter of the valve body.
- (2) Install the two "O" rings, and seal on the plunger assembly.
- (3) Install the cushion ring on the plunger assembly.
- (4) Install the rear seal into the rear seal retainer with the lip of the seal toward the small end of the retainer.
- (5) Install the "O" ring on the outside diameter of the rear seal retainer.
- (6) Insert the rear seal retainer assembly into the hub of the rear cover.
- (7) Holding the seal retainer in place invert the cover over a large socket to support the seal retainer in place.
- (8) Apply downward pressure on the rear cover and install the retainer ring (Fig. 26).
- (9) Install the plunger assembly into the valve body.
- (10) Install the valve into the valve body with the rubber insert contacting the valve seat.
- (11) Install the load ring onto the plunger with the concave face out.
- (12) Press downward on the valve body and insert

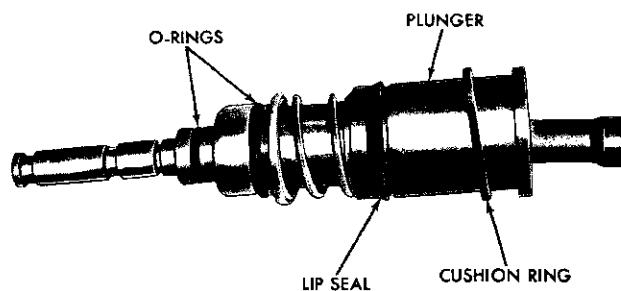

Fig. 33—Valve Plunger Assembly

the spring clip into the groove of the plunger.

(13) Install the levers and fulcrum ring into the rubber retainer.

(14) Align the indexing tab with the notch in the valve body and insert the assembly into the valve body with the fulcrum ring on the underside.

(15) Install the two plastic rings onto the plunger shaft.

(16) Install the master cylinder push rod onto the plunger assembly.

(17) Install the bellows into the bellows retainer and install the retaining ring onto the bellows.

(18) Place the valve body assembly into the detents of the diaphragm and install the bellows and retainer assembly.

(19) Install the bellows retainer snap ring.

(20) Install the diaphragm and valve assembly into the rear cover.

(21) Align the scribe marks and place the front cover over the bellows and master cylinder push rod.

(22) Squeeze the two housings and align the holes with the channel and install the ten screws.

(23) Pull the lip of the bellows up through the front housing.

(24) Clean the filter and the plastic breather.

(25) Install the retaining plate and the attaching screws.

(26) Install the master cylinder and the four attaching nuts.

(27) Install the booster assembly into the dash and tighten the attaching nuts.

(28) Connect the brake line and the vacuum hose.

(29) Bleed the brakes.

REMOTE POWER BRAKE (C-300J)

The remote power brake system for the C-300J Models consist of a control valve, a vacuum suspended booster and a slave cylinder assembly, mounted on brackets under the left front fender, just back of the headlamp housing (Fig. 34).

It breathes through an air filter assembly mounted inside of the left front fender side shield just under the battery tray. A strap integral with the filter housing serves as a mounting bracket (Fig. 35).

All in-line check valve is used in the vacuum line. The residual pressure check valve is contained in the slave cylinder assembly, rather than being located in the master cylinder as it is in the other brake systems.

CAUTION: When servicing the master cylinder, do not install a residual check valve or the booster will not permit the brakes to release fully.

SERVICE PROCEDURES

18. REMOTE POWER BRAKE

Removal

(1) Remove the hose clamps that secure the air hose and vacuum hose to the control valve housing and to the booster.

(2) Disconnect the master cylinder line and wheel cylinder line at the tubing connectors on the slave cylinder housing.

(3) Remove the two retaining screws that secure the slave cylinder housing to the mounting bracket, and remove the power brake assembly from the vehicle.

(4) Remove the filter retaining nut and bolt and remove the filter assembly from the inner side of the fender side shield.

Disassembly

(1) Disconnect the by-pass tube from the connector on the side of the control valve housing. Pull the by pass tube rearward and out of the rubber grommet in the rear housing.

(2) Scribe a reference line on the two housings of the booster and on the clamping band, and remove the nut and bolt from the clamping band. Remove the clamping band and the front housing.

(3) Pull outward on the diaphragm to remove the power piston assembly (diaphragm, push rod, and diaphragm return spring) (Fig. 36). Bend back the three tabs on the diaphragm plate to disengage the diaphragm return spring. Remove the lock nut from the end of the push rod and pull the push rod out of

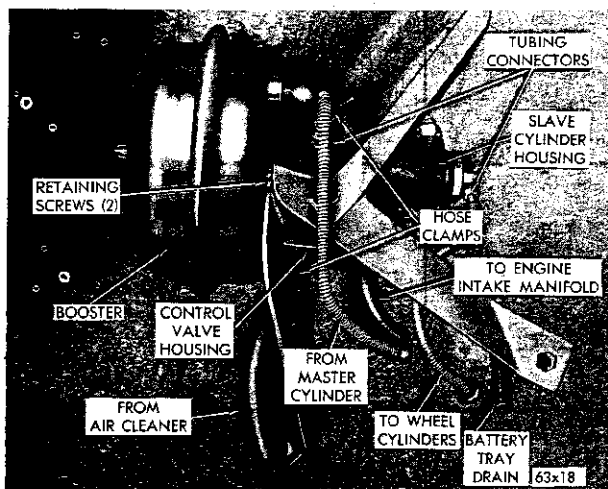

Fig. 34—Remote Control Booster Assembly

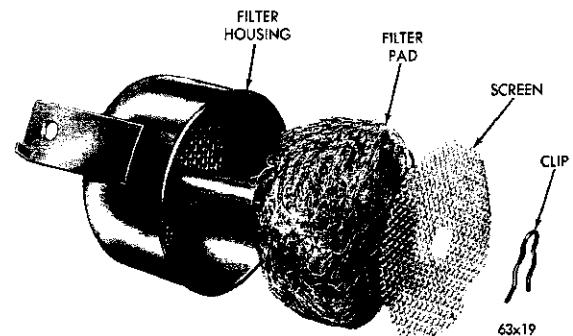

Fig. 35—Air Filter Assembly

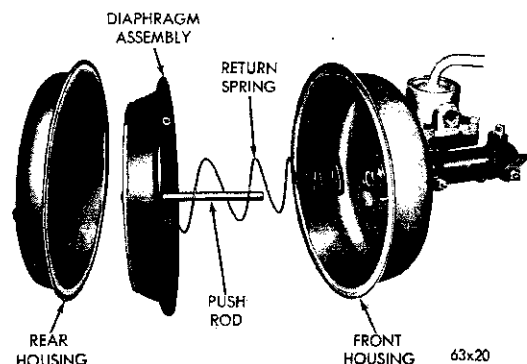

Fig. 36—Remote Control Booster Assembly (Disassembled)

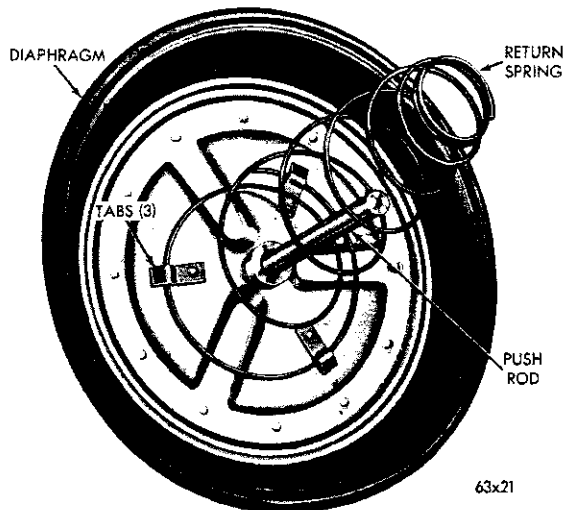

Fig. 37—Piston, Rod and Return Spring

the diaphragm hub (Fig. 37).

(4) Scribe reference marks on the flanges of the control valve cover and slave cylinder housing. Remove the large snap ring and breather cap assembly from the control valve cover (Fig. 38). Remove four cap screws and lock washers that secure the control valve cover to the slave cylinder housing, and separate the two housings. The air check valve assembly consists of a metal poppet, a spring, and an "O" ring which seats in a counter bore in the control valve housing. Compress the air check valve spring and, using a slender screw driver remove and discard the small "O" ring from the check valve poppet (Fig. 39). Remove the poppet and spring.

(5) The control valve assembly consists of a piston assembly, a rubber diaphragm, a diaphragm plate and a Tinnerman nut (Fig. 40). The piston assembly

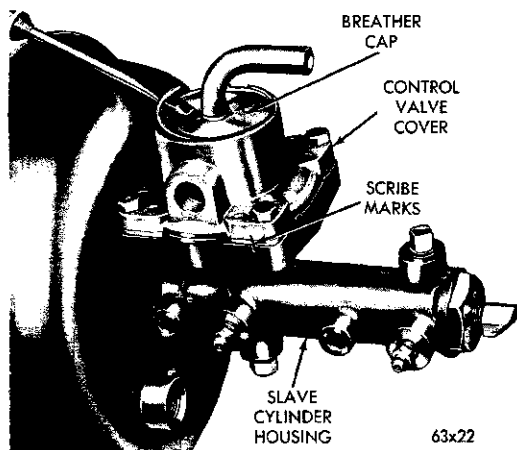

Fig. 38—Control Valve Housing

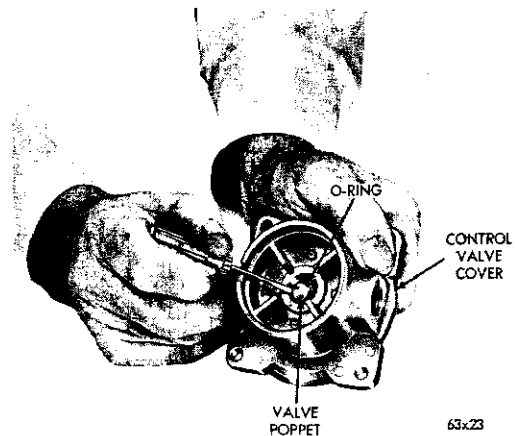

Fig. 39—Control Valve Poppet

consists of a spool section with two lip seals, and a flange section with a seal in a counterbore in the hub of the flange. The spool section and flange section are serviced as an assembly. Grasp the hub of the control valve piston and, with a rotating motion, pull the control valve assembly out of its seat in the slave cylinder housing. Pry up the corners of the Tinnerman nut to disengage them from the piston hub and remove the Tinnerman nut, diaphragm plate and diaphragm from the piston assembly. Remove the rubber seal from the counterbore in the hub of the piston assembly. Remove and discard the outermost lip seal on the spool section of the piston. The other lip seal on the spool section is serviced in assembly with the piston. (It cannot be installed after the spool and flange sections are pressed together without overstretching the rubber.)

(6) Using a 1 $\frac{3}{16}$ " socket unscrew the end cap from the front end of the slave cylinder housing. Remove and discard the copper washer that serves as a seal between the end cap nut and the slave cylinder housing. Remove and discard the rubber washer inside the end cap. This washer serves as a seat for the residual check valve. Remove the piston return spring and residual check valve from the slave cylinder bore and discard the check valve (Fig. 41).

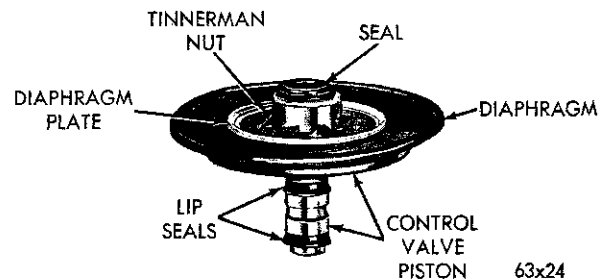

Fig. 40—Control Valve Assembly

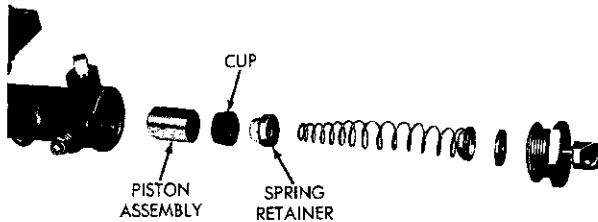

Fig. 41—Slave Cylinder

(7) Using a standard $1\frac{1}{8}$ " socket, unscrew the push rod guide bushing from the slave cylinder housing and remove the front shell, a thick spacer washer and a lock washer. Remove and discard the "O" ring from the rolled tube that protrudes from the back of the control valve housing, and the gasket that seals between the control valve housing and the front shell of the booster. Remove and discard the "O" ring from a groove around the front end of the guide bushing (Fig. 42). Remove the Truarc snap ring, flat washer and lip seal from the counterbore in the front end of the guide bushing. Discard the seal. Remove the Truarc snap ring and lip seal from the counter bore in the rear end of the guide bushing. Discard the seal. Insert a slender screw driver forward through the slave cylinder bore and push the slave cylinder piston assembly, cup, and spring retainer out through the front of the bore. Discard the cup.

(8) The slave piston assembly is serviced as an assembly. Within the piston body there is a loose fitting plug, a plug return spring, and a snap ring. It may be disassembled for cleaning and inspection by removing the snap ring. The plug has a rubber disc inserted

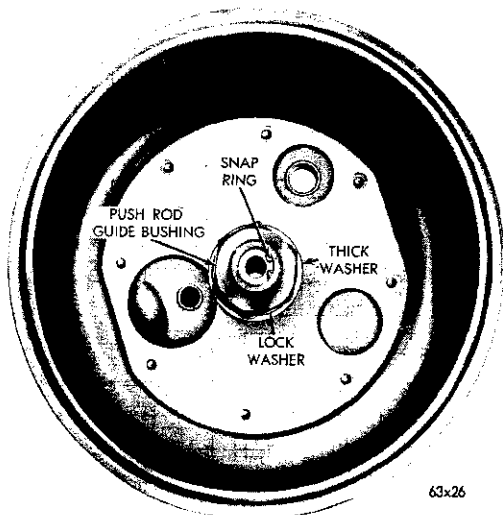

Fig. 42—Housing and Piston Guide

in its inner face which, when the brakes are applied, blocks off the orifice that leads to the slave cylinder chamber. Remove the two bleeder screws from the side of the slave cylinder housing to facilitate cleaning. Disassemble the air cleaner by removing the retaining clip, screen and hair pad (Fig. 35).

Cleaning and Inspection

Wash all internal metal parts that come in contact with brake fluid in alcohol. Wipe thoroughly with clean cloths. Use compressed air to dry all internal passages. Discard all rubber parts and gaskets, including the large copper washer that seals between the end cap and the slave cylinder housing. Clean the air filter pad in mineral spirits and air dry.

Examine the control valve piston bore and slave cylinder bore for evidence of wear or corrosion. Replace the housing if necessary.

Test the check valve in the vacuum line and replace it if necessary.

Examine hoses, tubing and fittings for evidence of leaks, excessive wear or damage, and replace as required.

Reassembly

Push Rod Guide Bushing

(1) In the counterbore in the front (small) end of the bushing, install a new lip seal, with the lip out, and a Truarc snap ring. (Refer to Fig. 43).

(2) Install the lock washer, the thick spacer washer and a new "O" ring on the outside of the bushing.

(3) In the counterbore in the rear (large) end of the bushing install a new lip seal, with the lip in, the flat washer and the Truarc snap ring.

(4) Install a new rubber washer in the bore of the slave cylinder end cap and a new copper washer over the threaded end of the cap against the hex.

(5) Install the end cap assembly, tightening it securely. Install the tube elbow in the end cap, and the two bleeder screws in the slave cylinder housing.

(6) If the original control valve is to be used again, install a new lip seal in the outer groove of the piston spool. Install a new control valve diaphragm over the

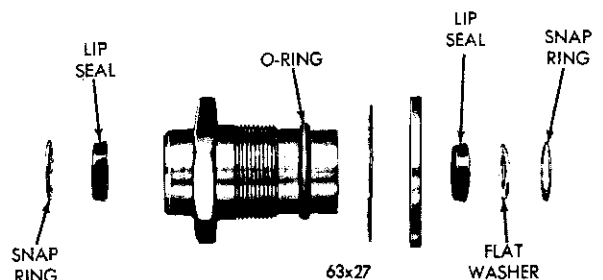

Fig. 43—Piston Guide Nut Assembly

5-22 BRAKES

hub of the piston flange, with the welt at the I.D. of the diaphragm next to the piston flange. Install the diaphragm plate and tinnerman nut.

(7) Install a new seal in the counterbore in the hub of the piston flange.

(8) With a rotating motion install the control valve assembly in the control valve housing.

(9) Install the air check valve spring and poppet, with a new "O" ring on the poppet.

(10) Install the control valve cover on the housing, aligning the scribe marks and tighten the four retaining screws.

(11) Install the breather cap and retaining ring in the control valve cover.

(12) Install a new diaphragm assembly on the push rod and tighten the retaining lock nut.

(13) Engage the large end loop of the return spring, under the three clips on the diaphragm plate and bend the tabs down to secure the spring.

(14) Install a new by-pass tube grommet in the rear shell and position the diaphragm and push rod assembly in the rear shell.

(15) Insert the free end of the push rod in the guide bushing bore and, with a rotating motion, slide it in

until the end of the push rod bottoms against the slave cylinder piston plug and the small end coil of the return spring seats around the hub of the guide bushing. Continue closing the two shells aligning the scribe marks and making sure that the welt on the O.D. of the diaphragm seats evenly between the grooved flanges of the shells. Install the clamp band. Tighten the clamp band bolt.

(16) Insert the unthreaded end of the by-pass tube through the grommet in the rear shell and connect the threaded end to the fitting on the control valve cover.

(17) Install the filter pad, wire screen and retaining clip in the filter housing.

Installation

(1) Position the power brake assembly on the mounting bracket and install the two retaining screws with a flat washer next to the bracket and then a lock washer.

(2) Connect the air hose to the breather cap and the vacuum hose to the booster exhaust.

(3) Connect the tube from the wheel cylinders to the fitting in the slave cylinder end cap.

(4) Connect the tube from the master cylinder to the slave cylinder. Bleed the brakes.

SERVICE DIAGNOSIS

PARKING BRAKE

| Condition | Possible Cause | Correction |
|--------------------------------|--|--|
| 19. Dragging Brake | (a) Improper cable or brake adjustment. | (a) Properly adjust the service brakes then adjust the parking brake cable. |
| | (b) Broken brake shoe return spring. | (b) Replace any broken return spring. |
| | (c) Broken brake shoe retainer spring. | (c) Replace the broken retainer spring. |
| | (d) Grease or brake fluid soaked lining. | (d) Replace the grease seal or recondition the wheel cylinders and replace both brake shoes. |
| | (e) Sticking or frozen brake cable. | (e) Clean and lubricate the cables. |
| | (f) Broken rear spring. | (f) Replace the broken rear spring. |
| | (g) Bent or rusted cable equalizer. | (g) Straighten, or replace and lubricate the equalizer. |
| 20. Brake Will Not Hold | (a) Broken or rusted brake cable. | (a) Replace or clean and lubricate the brake cable. |
| | (b) Improperly adjusted brake or cable. | (b) Adjust brakes and cable as necessary. |
| | (c) Soaked brake lining. | (c) Replace the brake lining. |
| | (d) Ratchet or pedal mechanism worn. | (d) Replace all worn parts. |

SERVICE DIAGNOSIS

SERVICE BRAKE

| Condition | Possible Cause | Correction |
|------------------------------------|---|--|
| 21. Pedal Goes to the Floor | (a) Fluid low in master cylinder. | (a) Fill and bleed the master cylinder. |
| | (b) Excessively worn brake lining. | (b) Reline and adjust the brakes. |
| | (c) Improperly adjusted brake shoes. | (c) Adjust the brakes and fill the master cylinder. |
| | (d) Leaking wheel cylinders. | (d) Recondition or replace the wheel cylinder and replace both brake shoes. |
| | (e) Loose or broken brake lines. | (e) Tighten all brake fittings or replace the brake line. |
| | (f) Air in hydraulic brake system. | (f) Fill and bleed the hydraulic brake system. |
| | (g) Leaking or worn master cylinder. | (g) Recondition or replace the master cylinder and bleed the hydraulic system. |
| 22. Spongy Brake Pedal | (a) Air in hydraulic system. | (a) Fill the master cylinder and bleed the hydraulic system. |
| | (b) Improper brake fluid (low boiling point). | (b) Drain, flush and refill with MoPar brake fluid. |
| | (c) Excessively worn or cracked brake drums. | (c) Replace all defective brake drums. |
| 23. Brakes Pulling | (a) Uneven tire pressure. | (a) Inflate all tires evenly. |
| | (b) Incorrect brake adjustment. | (b) Adjust the brakes and check the fluid. |
| | (c) Brake drums out of round. | (c) Grind or replace the brake drums. |
| | (d) Brake shoes distorted. | (d) Replace the faulty brake shoes. |
| | (e) Grease or brake fluid soaked lining. | (e) Replace the contaminated brake lining. |
| | (f) Unmatched brake lining. | (f) Match the primary, secondary and same type if lining on all wheels. |
| | (g) Restricted brake hose or line. | (g) Replace the plugged hose or brake line. |
| | (h) Front end out of alignment. | (h) Align the front end. |
| | (i) Broken rear spring. | (i) Replace the broken spring. |
| 24. Squealing Brakes | (a) Incorrect brake lining. | (a) Install matched brake lining. |
| | (b) Dust in brakes or scored brake drums. | (b) Blow out the brake assembly with compressed air and grind the brake drums. |
| | (c) Distorted brake shoes. | (c) Replace the brake shoes. |
| | (d) Bent support plate. | (d) Replace the support plate. |
| | (e) Broken or weak brake shoe return spring. | (e) Replace the return spring. |
| | (f) Weak or broken brake shoe retaining spring. | (f) Replace the retaining spring. |
| | (g) Glazed brake lining. | (g) Cam grind or replace the brake lining. |
| | (h) Saturated brake lining. | (h) Replace the saturated lining. |

SERVICE DIAGNOSIS

SERVICE BRAKES—(Continued)

| Condition | Possible Cause | Correction |
|-------------------------------------|--|--|
| 25. Dragging Brakes | (a) Incorrect brake adjustment. | (a) Adjust the brakes and check the fluid. |
| | (b) Parking brakes engaged. | (b) Release the parking brakes. |
| | (c) Wheel cylinder sticking. | (c) Recondition the wheel cylinder. |
| | (d) Weak or broken brake shoe return spring. | (d) Replace the brake shoe return spring. |
| | (e) Brake pedal binding. | (e) Free up and lubricate the brake pedal and linkage. |
| | (f) Master cylinder cup sticking. | (f) Recondition the master cylinder. |
| | (g) Incorrect master cylinder push rod adjustment. | (g) Properly adjust the master cylinder push rod. |
| | (h) Obstructed master cylinder relief port. | (h) Use compressed air and blow out the relief port. |
| | (i) Saturated brake lining. | (i) Replace the brake lining. |
| | (j) Bent or out of round brake drum. | (j) Grind or replace the faulty brake drum. |
| | 26. Hard Pedal | (a) Incorrect brake lining. |
| (b) Incorrect brake adjustment. | | (b) Adjust the brakes and check the fluid. |
| (c) Frozen brake pedal linkage. | | (c) Free up and lubricate the brake linkage. |
| (d) Restricted brake line or hose. | | (d) Clean out or replace the brake line or hose. |
| (e) Brake booster inoperative. | | (e) Recondition or replace the brake booster. |
| 27. Wheel Locks | (a) Loose or torn brake lining. | (a) Replace the brake lining. |
| | (b) Incorrect wheel bearing adjustment. | (b) Clean, pack and adjust the wheel bearings. |
| | (c) Wheel cylinder cups sticking. | (c) Recondition or replace the wheel cylinder. |
| | (d) Saturated brake lining. | (d) Reline both front or rears or all four brakes. |
| 28. Brakes Fade (High Speed) | (a) Improper brake adjustment. | (a) Adjust the brakes and check the fluid. |
| | (b) Distorted or out of round brake drums. | (b) Grind or replace the drums. |
| | (c) Overheated brake drums. | (c) Inspect for dragging brakes. |
| | (d) Incorrect brake fluid (low boiling temperature). | (d) Drain, flush, refill and bleed the hydraulic brake system. |
| | (e) Saturated brake lining. | (e) Reline both front or rear or all four brakes. |
| 29. Pedal Pulsates | (a) Bent or out of round brake drum. | (a) Grind or replace the brake drums. |
| 30. Brake Chatter | (a) Rough or scored brake drum. | (a) Grind or replace the brake drum. |
| | (b) Loose support plate. | (b) Tighten the support plate bolts to the proper torque. |

SERVICE DIAGNOSIS

SERVICE BRAKES—(Continued)

| Condition | Possible Cause | Correction |
|--------------------------------------|--|---|
| | (c) Bent support plate. | (c) Replace the support plate. |
| | (d) Distorted brake shoes. | (d) Replace the brake shoes. |
| | (e) Machine grooves in the contact face of the brake drum. | (e) Grind or replace the brake drum. |
| | (f) Saturated brake lining. | (f) Replace both front or both rear or all four brakes. |
| 31. Brakes Do Not Self Adjust | (a) Adjuster screw frozen in the thread. | (a) Clean and free-up all thread areas. |
| | (b) Adjuster screw corroded at the thrust washer. | (b) Clean the threads and replace the thrust washer if necessary. |

POWER BRAKES

To determine whether the power unit is functioning, shut off the engine and apply the brakes several times to exhaust the vacuum from the system. Then lightly apply the brakes and start the engine. If the power unit is operating, the brake pedal will move forward slightly and less pedal pressure will be needed to apply the brakes.

If no vacuum is felt, inspect the vacuum line for kinks or disconnection. A method of testing for an internal leak in the power unit is to apply the brakes, then hold the brakes on and stop the engine. After approximately one minute there should be enough vacuum left to give power assist for several applications.

| | | |
|---|--|--|
| 32. Dragging Brakes (All Wheels) | (a) Brake shoes improperly adjusted. | (a) Adjust the brakes. |
| | (b) Brake pedal linkage binding. | (b) Free up the linkage. |
| | (c) Excessive hydraulic seal friction. | (c) Lubricate the seal. |
| | (d) Compensator port plugged. | (d) Clean out the master cylinder. |
| | (e) Sticking valve plunger. | (e) Free up and lubricate the valve plunger. |
| | (f) Improper booster push rod length adjustment. | (f) Adjust the push rod. |
| | (g) Fluid cannot return to master cylinder. | (g) Inspect the pedal return and push rod adjustment. |
| 33. Grabbing Brakes | (a) Grease or brake fluid on linings. | (a) Inspect for a leak and replace the lining as required. |
| | (b) Sticking actuating valve. | (b) Free up the valve. |
| 34. Pedal Goes to Floor (or almost to floor) | (a) Self-adjusters not operating. | (a) Inspect the self-adjuster operations. |
| | (b) Air in hydraulic system. | (b) Bleed the brakes. |
| | (c) Hydraulic leak. | (c) Locate and correct the leak. |
| | (d) Fluid low in master cylinder. | (d) Add brake fluid. |
| | (e) Shoe hanging up on rough platform. | (e) Smooth and lubricate the platforms. |
| 35. Hard Pedal (Power Unit Trouble) | (a) Faulty vacuum check valve. | (a) Replace the check valve. |
| | (b) Collapsed or leaking vacuum hose. | (b) Replace the hose. |
| | (c) Plugged vacuum fittings. | (c) Clean out the fittings. |
| | (d) Leaking vacuum chamber. | (d) Locate and correct the leak. |

SERVICE DIAGNOSIS
POWER BRAKES—(Continued)

| Condition | Possible Cause | Correction |
|--|--|----------------------------------|
| 36. Self-Application of Brakes When Engine Starts | (e) Diaphragm assembly out of place in housing. | (e) Position the diaphragm. |
| | (f) Vacuum leak in forward vacuum housing. | (f) Locate and correct the leak. |
| | (g) Broken plunger stem. | (g) Replace the plunger stem. |
| | (a) Leak in rear housing. | (a) Locate and correct the leak. |
| | (b) Diaphragm out of location in housings and allowing atmospheric pressure into rear chamber. | (b) Position the diaphragm. |
| | (c) Sticking or unseated actuating valve assembly. | (c) Free up and seat properly. |
| | 37. Grunting Noise in Booster on Application | (a) Air in hydraulic system. |
| (b) Lack of valve plunger lubrication. | | (b) Lubricate the plunger. |
| (c) Fluid low in master cylinder. | | (c) Add brake fluid. |