

**GROUP 1**  
**ACCESSORIES (RADIOS, HEATERS, MIRRORS)**

**CONTENTS**

**RADIO**

	Page		Page
Antenna Trimmer Adjustment . . . . .	3	On-Off Switch and Volume Control . . . . .	2
Electric Antenna . . . . .	5	Push Button Adjustment . . . . .	3
Fader Control Performance . . . . .	4	Radio Controls . . . . .	2
Foot Switch for Search Tuning . . . . .	3	Radio Removal and Installation . . . . .	2
Interference Elimination . . . . .	4	Service Diagnosis . . . . .	25
Local and Distant Push Buttons . . . . .	3	Wiring Diagrams . . . . .	7
Manual Antenna . . . . .	4		

**HEATER**

Heater Blower . . . . .	11	Rear Window Defroster . . . . .	10
Heater Core . . . . .	11	Vent Deflector—Replacement . . . . .	11
Heater Vacuum Actuator Replacement . . . . .	11	Service Diagnosis . . . . .	26

**AUTOMATIC BEAM CHANGER**

Aiming the Automatic Beam Changer . . . . .	12	Operation . . . . .	12
Aiming the Scanner . . . . .	13	Service Diagnosis . . . . .	27
Driver Adjustments . . . . .	12		

**MIRROR-MATIC ELECTRONIC REAR VIEW MIRROR**

Driver Adjustment . . . . .	14	Removal and Disassembly . . . . .	14
Inspection and Trouble Shooting . . . . .	14	Service Diagnosis . . . . .	27

**REMOTE CONTROL OUTSIDE MIRROR**

Operation . . . . .	15	Removal and Installation . . . . .	15
---------------------	----	------------------------------------	----

**ELECTRIC CLOCK**

Removal and Installation . . . . .	16	Service Diagnosis . . . . .	28
------------------------------------	----	-----------------------------	----

**WINDSHIELD WASHER**

Operation . . . . .	17	Service Diagnosis . . . . .	28
Two Gear Pump . . . . .	17		

**AUTO-PILOT**

Control Cable Adjustment . . . . .	22	Locking Arm Latch and Contact Point Adjustment . . . . .	20
General Information . . . . .	17	Servicing the Auto-Pilot . . . . .	22
Linkage Adjustment . . . . .	21	Tests . . . . .	19

**GROUP 1**

**ACCESSORIES, RADIOS, HEATERS, MIRRORS**

**RADIOS**

All Chrysler vehicles are equipped with all transistor powered radio models 343 and 411. All Imperial vehicles are equipped with radio model 413 which is electrically identical to the model 411.

Model 343 is a push button type radio with continuously variable tone and rear speaker control. Radio models 411 and 413 are search tuned radios with a step position tone and a rear speaker control.

**Radio Controls (Figs. 1 and 2)**

On the push button radios, tuning is controlled

by five push buttons and the manual tuning knob is to the right of the radio dial. On the search tuned radios Models 411 and 413 the tuning is controlled manually by five push buttons and the tuning knob. The search tuning is controlled by two additional push buttons and a foot switch.

The volume, tone and the on-off switch are controlled by the dual knob to the left of the radio dial. The rear speaker fader control (if so equipped) and the tuning knob are located to the right of the radio dial.

**SERVICE PROCEDURES**

**1. RADIO**

**CAUTION:** Do not operate the radio with the speaker detached; since damage to the transistors may result. If the rear seat speaker is disconnected from the radio, insert a jumper wire to the rear seat speaker socket (Fig. 3) to allow the receiver to operate.

**Removal (Chrysler Vehicles)**

- (1) Disconnect the battery ground cable.
- (2) Remove the upper and lower instrument panel mouldings.
- (3) Remove the speaker grille.
- (4) Remove the speaker and mounting plate attaching screws.

(5) Disconnect the speaker leads and remove the speaker assembly.

(6) Disconnect the "A" lead, light lead, antenna lead and the foot selector switch lead (if so

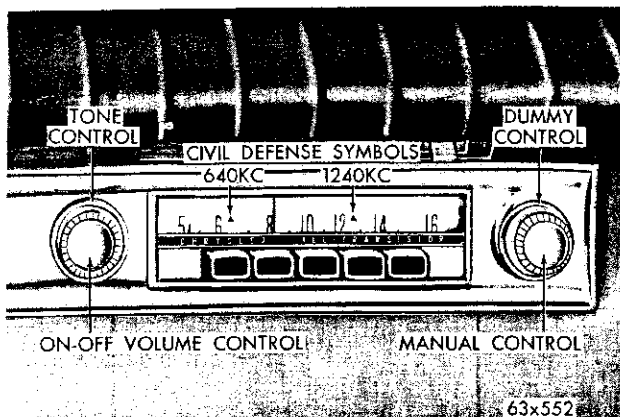

**Fig. 1—Radio Controls (Model 343)**

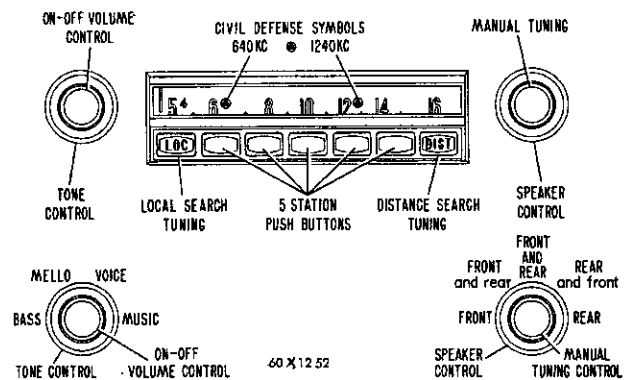

**Fig. 2—Radio Controls (Model 411-413)**

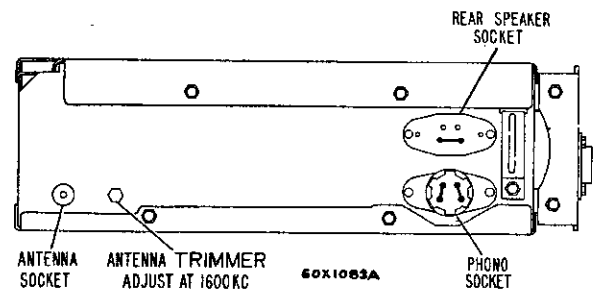

**Fig. 3—Antenna Trimmer**

equipped).

(7) Remove the radio control knobs and shaft mounting nuts.

(8) Remove the radio to dash support brackets and remove the radio through the opening in the instrument panel.

#### **Removal (Imperial Models)**

(1) Disconnect the battery negative terminal.

(2) Remove the radio-to-dash support bracket.

(3) Remove the 2 screws attaching the fuse block to the instrument panel and lower the fuse block to facilitate removal of the radio.

(4) Disconnect the "A" lead light lead, front and rear speaker leads, antenna leads and foot control switch connectors.

(5) Withdraw the radio assembly from the underside of the instrument panel.

#### **Installation (Chrysler Vehicles)**

(1) Position the radio in the instrument panel and install the radio to panel bracket.

(2) Install the radio control shaft nuts and control knobs.

(3) Connect the radio "A" lead, light lead, antenna lead and the foot selector switch lead (if so equipped).

(4) Connect the speaker leads to the speaker and position the speaker and mounting plate in the instrument panel.

(5) Install the speaker mounting plate screws.

(6) Install the speaker grille.

(7) Install the upper and lower instrument panel mouldings.

(8) Connect the battery ground cable.

(9) Test the operation of the radio.

#### **Installation (Imperial Models)**

(1) Install the radio assembly from the underside of the instrument panel.

(2) Install the radio-to-dash support bracket and radio attaching nuts.

(3) Connect the antenna light "A" lead, speaker leads and rear seat speaker leads and foot selector switch connector.

(4) Connect the battery.

## **2. PUSH BUTTONS**

### **Adjustment**

(1) Extend the antenna fully and turn the radio on for fifteen minutes.

(2) Unlock the push button by pulling it out and manually tune in the desired station.

(3) Push the button back into position to lock the adjustment.

(4) Repeat the operation on the other push buttons.

### **Local and Distant Push Buttons**

Local push button will tune the receiver to only strong signal stations. Distant push button will tune the receiver to most of the stations within range of the radio. For weak stations, manual control should be used for precise tuning.

## **3. FOOT SWITCH FOR SEARCH TUNING**

The foot switch for search tuning, on Models 411 and 413 is located on the left forward end of the floor panel. By depressing the foot switch, it will select a station on the radio.

The foot switch activates the tuner mechanism in the same manner as the search-tuning buttons "(LOC and DIST)." Therefore, the foot switch will cause the search-tuner to operate at a sensitivity predetermined by which of the two search-tuning buttons was last depressed.

## **4. ANTENNA TRIMMER ADJUSTMENT (Fig. 3)**

**CAUTION:** The antenna compensator must be properly adjusted for the satisfactory operation of the radio.

The antenna trimmer receives its original adjustment at the time the set is manufactured; however, a final adjustment must be made so that the radio can be matched exactly to the specific antenna used in each vehicle. Generally a quarter of a turn of this trimmer in either direction will match the antenna to the radio. With the antenna fully extended, tune the radio to the general area of 1600 KC on the dial—preferably off station—and turn up the volume until a hissing sound is heard. Then, with the antenna fully extended adjust the antenna compensator (located on the rear of the radio chassis) by carefully rotating it back and forth until a position is found that gives peak response and maximum volume. Unless the receiver is properly aligned to the antenna optimum performance cannot be obtained. This is particularly true in the case of the search tuner where the signal strength materially affects the over-all efficiency of the radio receiver. The same procedure can be followed when using a weak station to adjust the compensator for maximum signal volume. When this hissing sound is at its maximum or the station volume is greatest, the antenna compensator is properly adjusted and should be left in this position.

## 1-4 ACCESSORIES

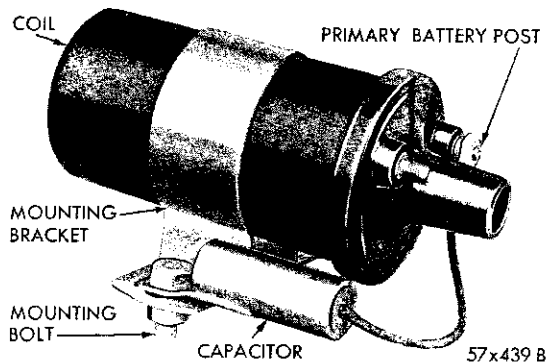

Fig. 4—Ignition Coil Capacitor

### 5. FADER CONTROL PERFORMANCE

This control is used only when the vehicle is equipped with a rear seat speaker. Positioning the control in one extreme position allows operation of the rear seat speaker. Rotating the control to the extreme opposite position allows both speakers to operate with varying volume as desired, or with equal volume at mid-position.

On the 411-413 Models, a five position switch speaker fader control is used in conjunction with the rear speaker. This new feature provides an extremely wide range of sound level variation between the front and rear compartments without the usual degree of precise tuning required of the normal variable controls.

### 6. INTERFERENCE ELIMINATION

When installing suppression items, make certain that all paint and dirt have been removed from the grounding area between the capacitors and the engine or body components. Tighten all nuts and bolts securely.

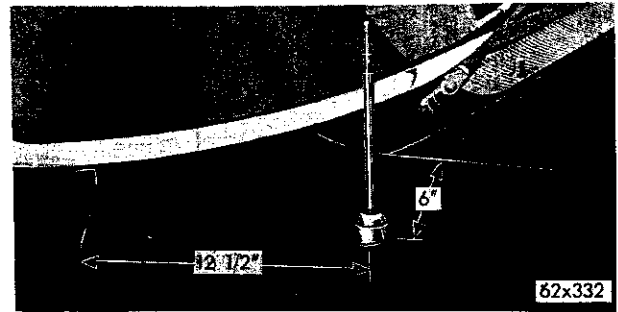

Fig. 5—Antenna Location (Imperial)

The high tension portion of the engine ignition system uses radio resistance wire as standard equipment.

The ignition coil capacitor is installed, as shown in Figure 4.

The alternator does not require the interference capacitor.

### 7. MANUAL ANTENNA EQUIPPED VEHICLES

#### Removal

(1) On the front fender antenna equipped models (Figs. 5 and 6) unplug the antenna lead-in wire from the radio set at instrument panel. On rear mounted antennas, unplug the antenna short lead from the extension cable at the "Y" connector located in the trunk compartment.

(2) Lower the antenna.

(3) Remove the plastic cap and nut attaching the antenna to rear wheel housing.

(4) Remove the nut, plastic adapter, gasket and ground collar.

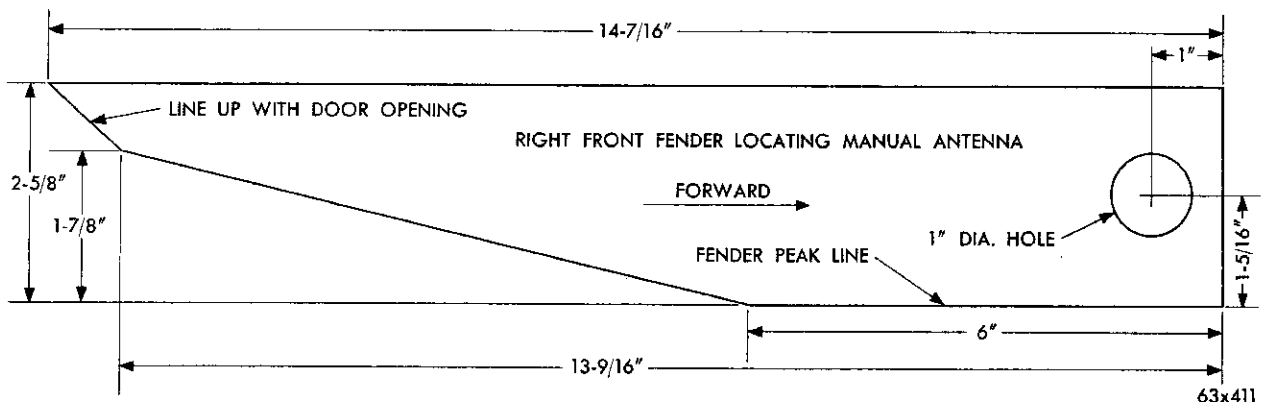

Fig. 6—Antenna Location (Chrysler)

(5) Remove the antenna assembly.

When installing the antenna, care should be taken to route the "lead-in" cable over the glove box compartment to allow for ample cable length when plugging the "lead-in" cable into the radio receptacle.

### Installation

(1) Install the antenna rod, lower adapter and mount the antenna to quarter panel or front fender.

(2) Install the gasket, upper adapter and attaching nut.

(3) Tighten the attaching nut and install the nut plastic cap.

(4) Install the lead-in cable to "Y" connector on rear mounted antenna and in radio set on front fender equipped models.

(5) Test the radio for proper operation.

## 8. THE ELECTRIC ANTENNA

The electric radio antenna (Fig. 7) used on Chrysler and Imperial vehicles is a telescoping type antenna, extended and retracted by a coiled nylon cord powered by a two direction electric motor. The main components of the electric antenna are the motor and drive assembly, the mast assembly and the support tube assembly. The antenna is serviced as a mast assembly, motor and the drive assembly, connector, pad and pin assembly, "lead-in" assembly and the necessary switches.

Many antenna problems may be avoided by frequent cleaning of the antenna mast telescoping sections. This may be performed when the car is being washed by cleaning the antenna mast sections with a clean soft cloth. In the winter, wipe the clean antenna sections with a cloth moistened with light oil.

If the antenna fails to operate satisfactorily, the problems can be divided into two general categories:

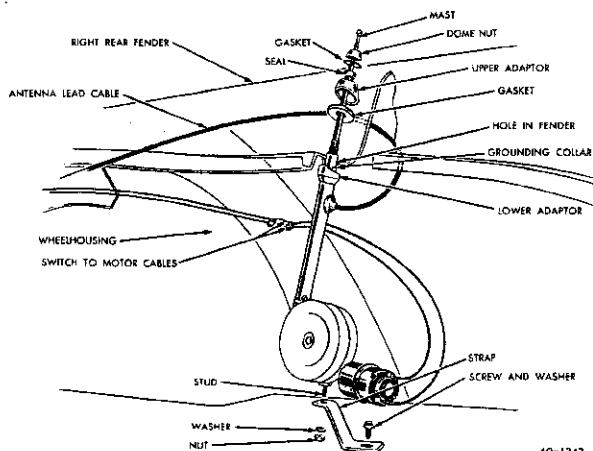

Fig. 7—Motorized Antenna Location—Front (Imperial Only)

(a) reception and (b) operational.

(a) Weak, intermittent, noisy, or no reception: Generally caused by a broken "lead-in" wire, poor connection, faulty insulation or the mast or "lead-in" wire, or moisture in the antenna body tube.

(b) Failure of the antenna to raise or lower: Generally can be traced to a blown fuse, faulty electrical connections at the switch or switch lead terminals, bent antenna mast rods, or a faulty motor and drive assembly.

Before an antenna is removed, the antenna performance should be tested to determine whether it is a reception problem or an operational problem.

## 9. TESTS

Clean the antenna and drive assembly before test or disassembly.

(1) With a source of 12 volt (D. C.) power, test the operation of the drive mechanism by grounding the negative (—) lead to the drive housing and with the positive (+) lead, contact the "yellow" (up) lead terminal to extend the antenna, and contact the "brown" (down) lead terminal to retract the antenna.

If the motor will not operate, replace the motor and drive assembly. If the motor runs freely and the antenna does not extend or retract, the mast assembly is at fault and should be replaced by a new mast. If the motor labors and the antenna extends and retracts very slowly, it may be caused by excessive dirt on the telescoping sections or bent telescoping mast rods. Clean and straighten the telescoping mast rods.

(2) Sometimes poor reception can be corrected by proper adjustment of the radio antenna trimmer. If this fails to produce the desired results, a substitute antenna known to be satisfactory may be plugged into the radio with the extended mast held out of the car window. (Do not ground the mast).

Upon establishing that the fault is in the antenna assembly, it may be traced to one or more of the following:

- (a) Broken "lead-in" wire or shielding.
- (b) Short "lead-in" wire or mast assembly.
- (c) Moisture in the support tube or "lead-in" assembly.
- (d) Poor connection (antenna "lead-in" assembly or shielding ground).

The preliminary test may indicate that removing the antenna from the vehicle is necessary for further checking, repairs or parts replacement. In this event, follow the procedure for antenna removal.

## Removal

- (1) Fully lower the antenna.

## 1-6 ACCESSORIES

- (2) Disconnect the motor leads at the connectors.
- (3) Disconnect the antenna "lead-in" wire at the antenna.
- (4) Remove the antenna mounting escutcheon nut. Remove the fender shield lower hole cover.
- (5) Remove the nut attaching the drive housing to the antenna lower mounting bracket.
- (6) Remove the antenna assembly, being careful not to bend the mast rod.

### Installation

- (1) Install the antenna and connect the leads.

**NOTE:** On the field installed dual rear antennas, care should be taken to route the rear antenna cable around the rear wheel housing behind the trunk liner to the "Y" connector located behind the rear slot in the luggage compartment so as to avoid interference from the hinges when opening and closing the lid.

- (2) Test the radio operation.

### Bench Test for Reception Malfunction

(a) With the test lamp and battery in the circuit, attach one test lead to the concentric pin on the "lead-in" connector and the other test lead to the mast sections. The lamp should "light" indicating continuity.

(b) Keeping the one lead on the connector pin, clip the other lead on the antenna support tube assembly. The lamp should "not light". If it does, look for a ground between the mast and support tube or inner conductor from the pin and pad.

(c) Remove the clip lead from the connector pin and clip it on the outer shell of the connector. Connect the other clip lead to the antenna support tube assembly. The lamp should "light" again. If it does not "light", the antenna shielding has an open circuit.

(d) Locate the ground or open circuit and repair or replace component parts as required.

**NOTE:** DO NOT attempt to service the details of the Motor and Drive Assembly. This sub-assembly must be serviced as a complete unit.

## 10. MOTOR AND DRIVE OR MAST ASSEMBLY

### Removal

- (1) Remove the (2) two screws holding the "lead-in" receptacle.
- (2) Unsolder the pin from the wire.
- (3) Remove the (3) screws which hold the "support tube" to the motor and drive assembly.
- (4) Holding the motor and drive assembly in one hand and the "support tube" in the other hand, pull

(applying back and forth rotary motion at the same time) until the support tube assembly is removed from antenna.

(5) Holding the motor and drive assembly in one hand and mast assembly in the other hand (grasp near bottom of mast assembly), rock the mast assembly back and forth and pull at the same time. This will remove the "insulator bushing" from "tubular fitting" and "outer mast section" from the remainder of antenna assembly.

(6) Apply 12 volts D.C. to the "yellow" (up) power lead and ground, until the entire length of the "nylon cord" has been expelled from the drive. To prevent a kink or bend in the "nylon cord", keep it taut by pulling on the mast.

**NOTE:** If motor and drive assembly is inoperative, manually remove the "nylon cord" from the drive.

**CAUTION:** DO NOT DISASSEMBLE THE MOTOR AND DRIVE ASSEMBLY FOR ANY PURPOSE.

In order to remove the "nylon cord" from the disabled motor and drive assembly, place the assembly in a vise so that the normal plane of the "nylon cord" is parallel with the floor, then using both hands pull on the "nylon cord" until it is completely expelled from the drive.

(7) Remove the "bottom insulator" and "water seal washer" (Fig. 8) from the "tubular fitting" using a wire hook and long nose pliers.

### Installation

- (1) If the original mast assembly is reused, thread

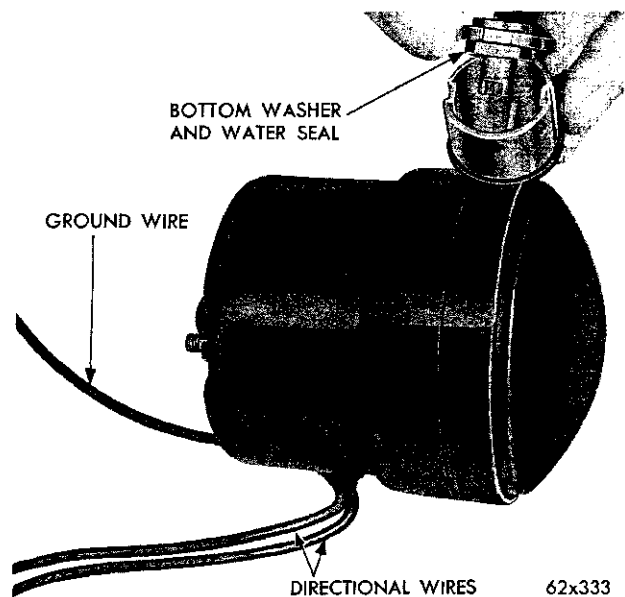

Fig. 8—Removing Bottom Insulator and Water Seal Washer

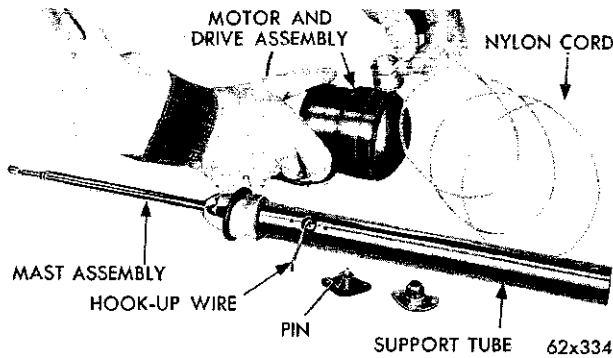

Fig. 9—Assembling Power Antenna

the "nylon cord" through the "bottom insulator" with the tubular projection down (Fig. 9). Then thread the "nylon cord" through the "water seal washers".  
**NOTE:** The "bottom insulator" and "water seal washer" are included on the service replacement mast assembly.

(2) Apply 12 volts D.C. to the "brown (down) power lead and ground. Feed approximately 12 inches of the nylon cord into the drive. Push the "water seal washer" and "bottom insulator" all the way down into the "tubular fitting". Apply 12 volt D.C. power until "nylon cord" disappears.

(3) Push the "outer mast section" down into the "tubular fitting". Make sure that the upper edge of the flange on the "insulator bushing" is below center of the 3 holes in the "tubular fitting".

(4) Install the support tube assembly in proper position making sure the hook-up wire is extended through the large hole in the body (Fig. 10).

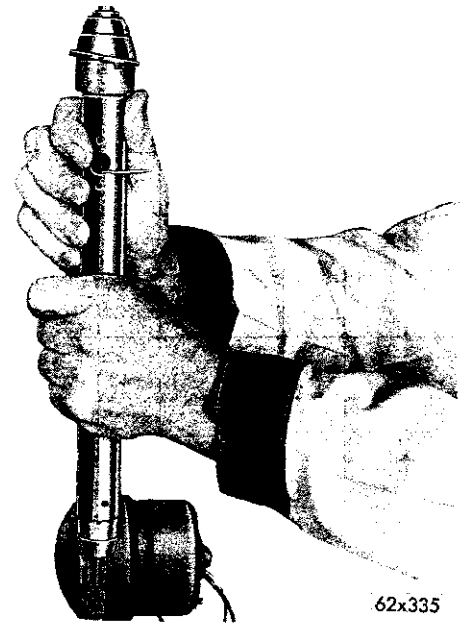

Fig. 10—Installing Mast Support

(5) Install the (3) screws to attach the support tube assembly to the motor and drive assembly.

(6) Solder the "hook-up wire" to the "pin".

(7) Assemble the "lead-in" receptacle with the (2) screws.

(8) Apply 12 volt power to the "yellow" and "brown" antenna leads and test for up and down operation.

**11. WIRING DIAGRAMS**

Refer to Figures 11 and 12 for the radio wiring diagrams.

**HEATER**

The hot water heating system (Fig. 13) is controlled by four push buttons and a temperature control lever (Fig. 14). A fifth push button independently controls the summer ventilation system.

**The Temperature Control Lever**—operates the water valve through a bowden cable. It is important that the bowden cable be adjusted to provide full opening and closing of the water valve for efficient functioning of the system.

**Summer Ventilation**—is controlled by opening of the ventilator air damper.

**For Heating**—air enters through the cowl intake passes through the heater core into the blower and

distribution duct through the opened shut-off damper.

**Defrosting**—is controlled by the defroster damper. For maximum defrosting or deicing, the temperature control lever must be set in the full warm position.

**Temperature Control Lever**—selects the temperature of the air discharged through the lower and upper outlets. When the lever is in the upper position air is not being heated. Air temperature is increased by moving the lever down toward the "WARM" position.

**OFF Button**—When the "OFF" button is pushed in, the system will not operate. The "OFF" button cuts off the current from the control lever switch and

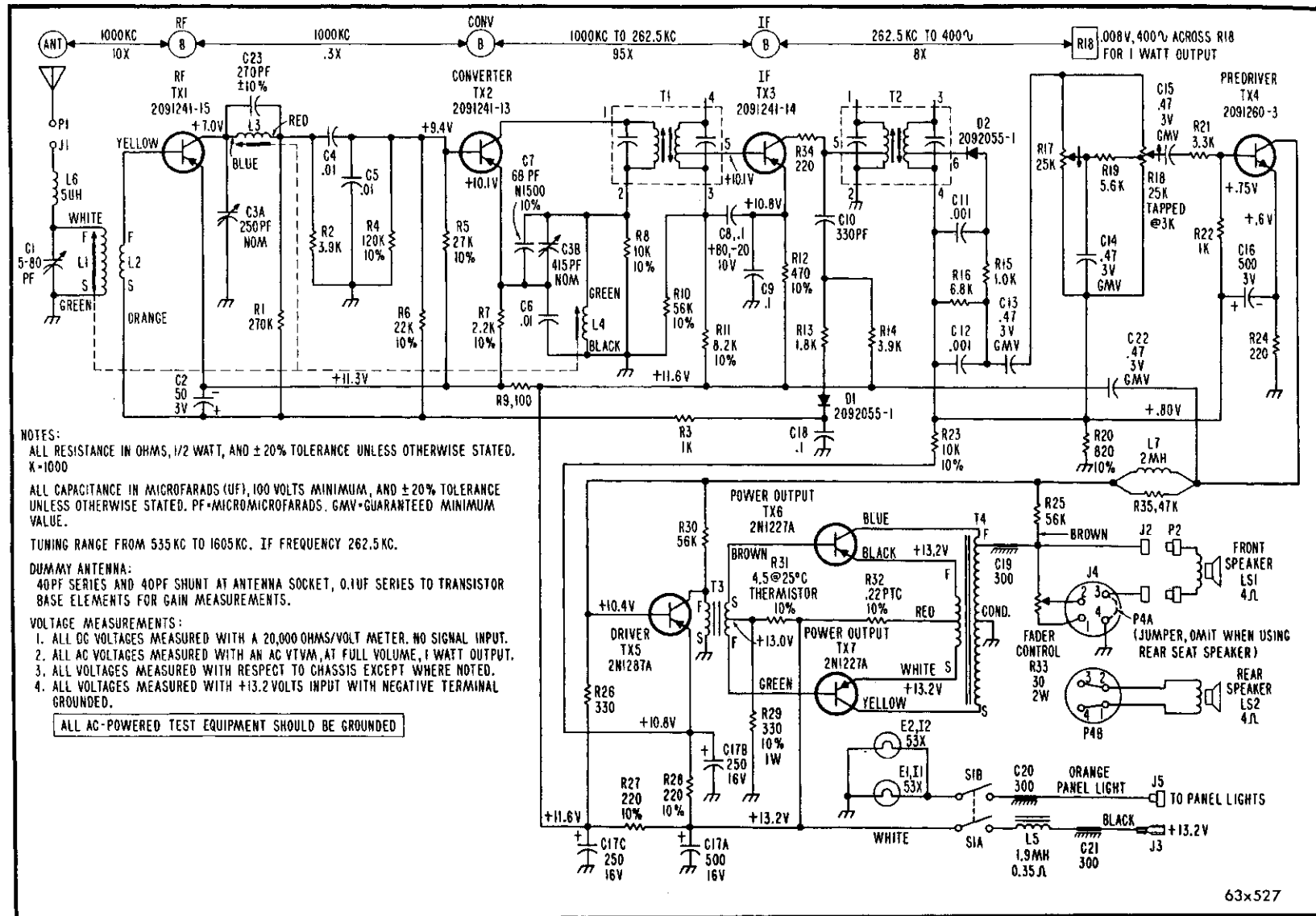

Fig. 11—Wiring Diagram—Radio Model 343

63x527



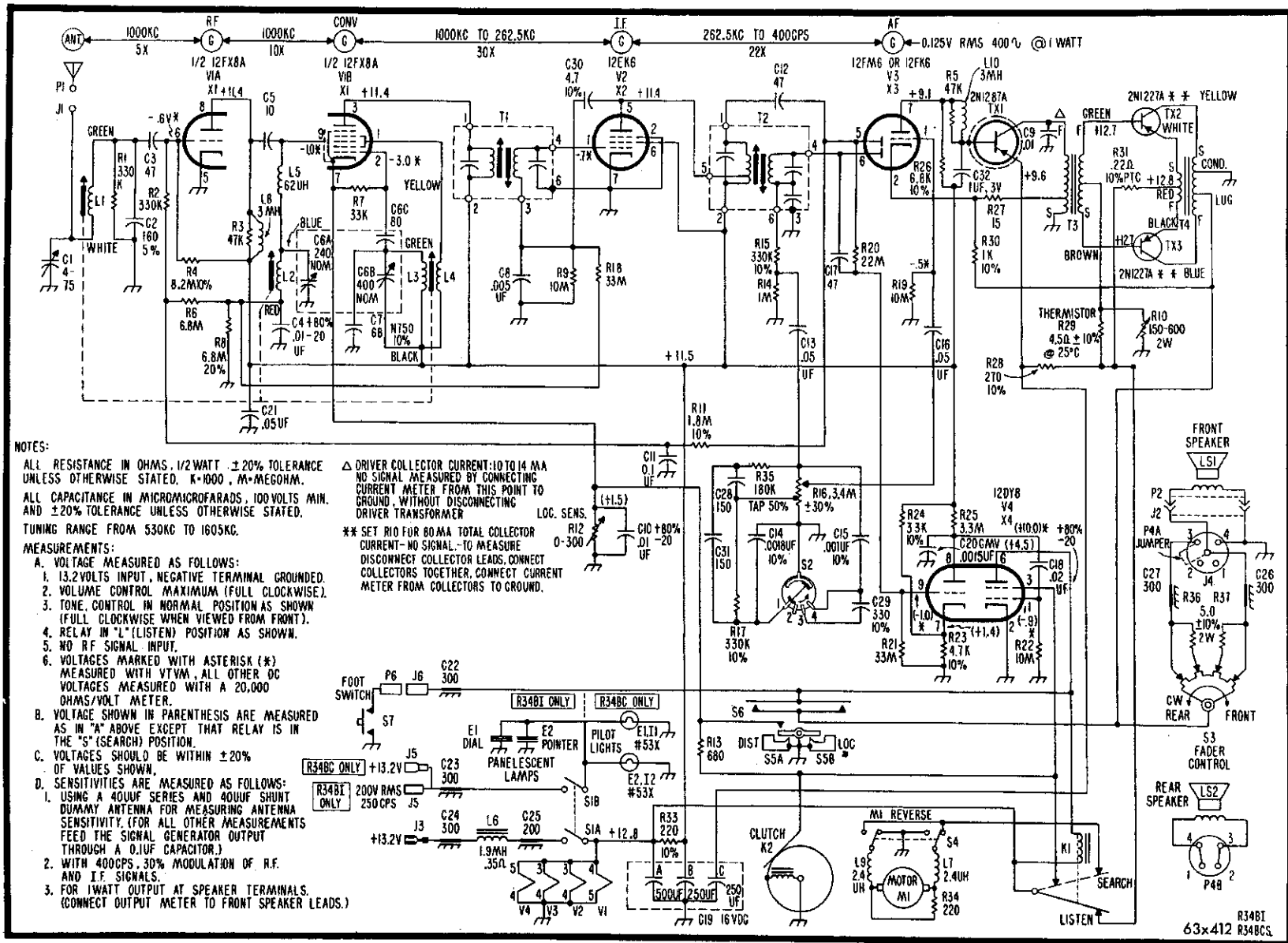

Fig. 12—Wiring Diagram—Radio Model 411 and 413

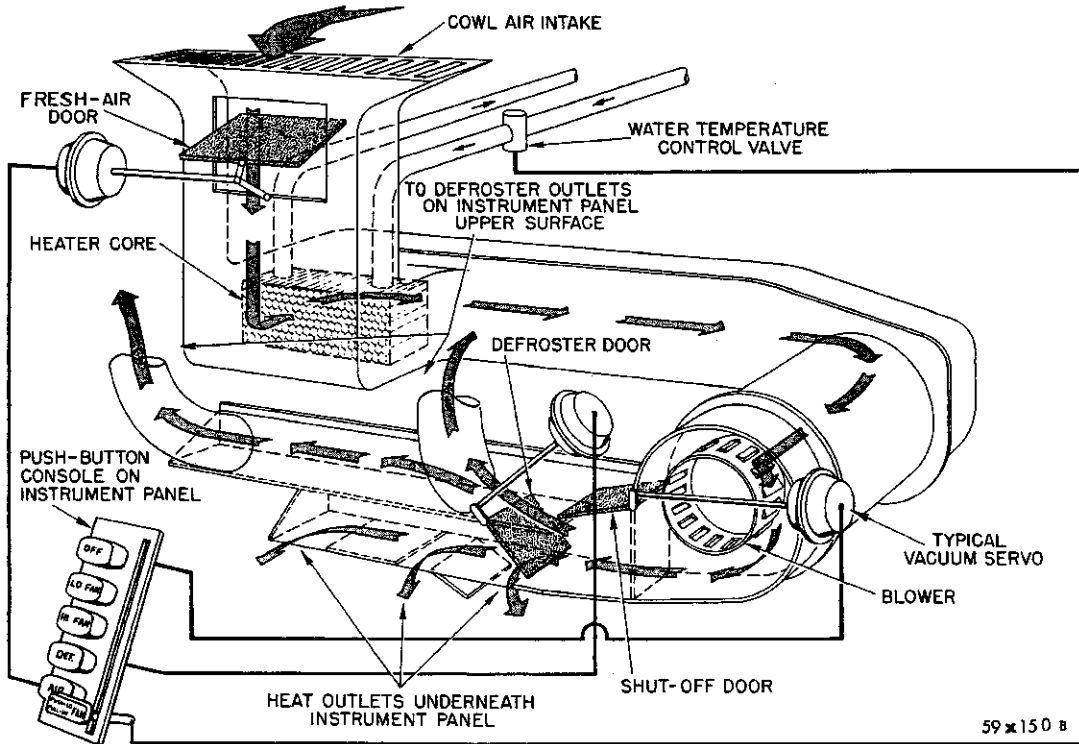

Fig. 13—Push Button Heater (Schematic View)

blower motor. The ventilation doors are closed, preventing outside air from entering the car.

**VENT Button**—Opens the ventilation door to allow outside air to enter the car directly. It does not operate the blower.

**DEF Button**—Causes a major portion of the air to be forced onto the windshield through the air outlets on top of the instrument panel for defrosting or defogging.

**“HI” Button**—Causes a major portion of air to be directed toward the car floor, at a high blower speed.

**“LO” Button**—Provides a gentle heat at a low blower speed.

**Heating the Vehicle**

Until the engine warms up, make sure the “OFF” button is pushed in and the temperature control lever is in the “WARM” position. Then, push in the “HI” button and leave the temperature control lever in the “WARM” position for a fast initial car warm-up. After warm-up use the “LO” button to adjust the speed as desired, and adjust the position of the temperature control lever to maintain desired temperature.

**NOTE:** When the “HI” button is pushed in, sufficient warm air will be forced onto the windshield through the upper air outlets for adequate defogging during normal driving conditions.

**Defrosting or Defogging the Windshield**

Push the “DEF” button for maximum defrosting

and move the temperature control lever to the “WARM” position.

**Summer Ventilation**

Push in the “VENT” button to open the ventilation door. Move the temperature control lever to the extreme upper position. The ventilation door may be left open during a rain.

**Rear Window Defroster (When So Equipped)**

A toggle switch. (at left and under the instrument panel) operates a blower which circulates air over the rear window to prevent fogging.

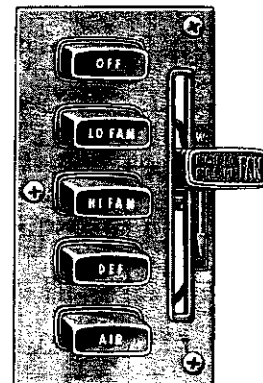

Fig. 14—Temperature Controls

## SERVICE PROCEDURES

## 12. HEATER BLOWER

**Removal (Fig. 15)**

- (1) Disconnect the battery ground cable.
- (2) Disconnect the heater ground wire at the windshield wiper motor mounting bracket.
- (3) Disconnect the heater wires from the harness connectors.
- (4) Disconnect the vacuum hoses at each vacuum unit.
- (5) Remove the hoses from their attaching clips.
- (6) Remove the heater valve capillary coil from the opening in the heater housing (driver's compartment, passenger side).
- (7) Remove the clips from the housing.
- (8) Remove the three screws attaching the heater distribution duct to the dash panel. (One is located to the left of the vent door and to the right of the brake pedal bracket; one below the heater at the passenger side and one screw is located at the windshield wiper motor right link pivot).

**NOTE:** To facilitate removal, disconnect the windshield wiper right link at the pivot to expose the housing screws.

- (9) Remove the housing and blower by pulling down and out of the driver's compartment.
- (10) Remove the blower, mounting plate and motor.

**Installation**

**NOTE:** If the blower motor was removed from the mounting plate be sure the mounting grommets are installed at the attaching bolts.

- (1) Install the blower motor and mounting plate

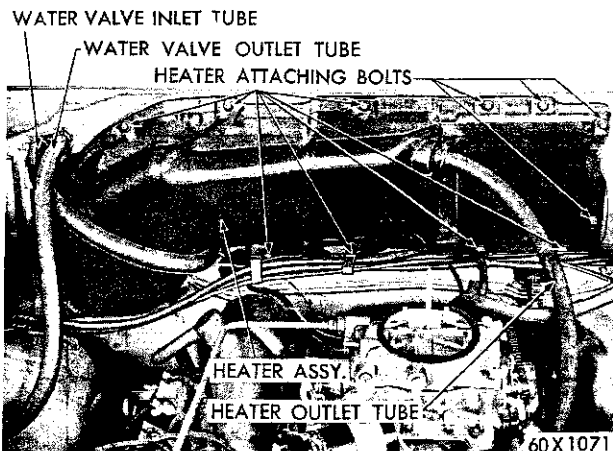

Fig. 15—Heater Removal

to the heater housing. Be sure the blower wheel is free and does not rub.

(2) Position the housing on dash panel and install the three attaching screws. There is a spacer at each attaching screw, be sure these spacers are installed between the heater housing and the dash panel when installing housing; otherwise, the housing could be damaged when tightening the screws.

(3) Reposition the heater water valve capillary coil in the heater housing and install the attaching clips.

(4) Connect the vacuum hoses at the vacuum unit and install the attaching clips.

(5) Connect the heater wire at the harness connectors and install the black ground wire at the windshield wiper motor bracket.

(6) Attach the windshield wiper motor pivot link (if disconnected).

(7) Connect the battery ground cable.

## 13. HEATER VACUUM ACTUATOR REPLACEMENT

(1) Disconnect the vacuum hoses.

(2) Remove the two nuts and lockwashers attaching the vacuum unit to the housing, and one clip attaching the vacuum unit rod to the actuator unit.

## 14. VENT DEFLECTOR—REPLACEMENT

The vent deflector is attached to the heater housing by three screws. This deflector should be removed whenever the radio is to be removed.

## 15. HEATER CORE

**Removal**

(1) Disconnect the battery ground cable.

(2) Drain the cooling system as necessary.

(3) Disconnect the heater hoses at the heater.

(4) Remove the screws attaching the heater core housing to the dash panel.

(5) Remove the housing and core as an assembly.

(6) Remove the mastic to expose the plastic rivets.

(7) Remove the heater core from the outer housing.

**NOTE:** The core is held in position in the outer housing with plastic rivets. Care should be used when pressing out these rivets to avoid damaging the housing or the rivets.

**Installation**

(1) Position the heater core in the heater outer housing and install the plastic rivets.

## 1-12 ACCESSORIES

- (2) Install new mastic.
- (3) Position the heater housing and core assembly on the dash panel.
- (4) Install all screws loosely, to insure proper alignment before tightening.
- (5) Connect the heater hoses at the heater.
- (6) Refill the cooling system as necessary.

### 16. REAR WINDOW DEFROSTER

The rear window defroster (optional on all Models)

is located on and under the rear shelf panel of the car, and consists of a blower, flexible hose and nozzle. A switch, located on the instrument panel, controls the blower for defrosting the rear window. The rear window defroster operates independently from the car heater. The air recirculated on the rear window glass is drawn by the defroster blower from air inside the car.

## AUTOMATIC BEAM CHANGER

The automatic beam changer is an automatic headlight control unit which senses the headlight intensity from other vehicles and automatically adjusts the headlights to a bright or dim setting.

A scanner and base assembly (Fig. 16) is mounted on top of the instrument panel. The control unit (Fig. 17) is mounted on a convenient structural part (grounding purposes) of the vehicles' body.

The automatic beam changer will dim the headlights when an oncoming car is seen at a distance of

approximately 1200 feet. The unit will reset the headlights on "bright" within approximately ½ second after the approaching car has passed.

The headlight setting can be interrupted by using the conventional dimmer switch. If the unit has a "bright" setting and the driver feels that a "dim" setting is required, he can override the automatic control by depressing the dimmer switch to obtain the "dim" condition. Automatic operation is restored when the driver again depresses the dimmer switch.

## SERVICE PROCEDURES

### 17. DRIVER ADJUSTMENTS

A knob located at the rear of the scanner unit, (Fig. 16), provides a sensitivity adjustment. If the headlights do not "dim" quickly enough upon approaching another vehicle it is an indication that sensitivity is set too "low" and correction is made by turning the scanner knob clockwise (to the right). If the headlights "dim" too soon, sensitivity can be decreased by turning the scanner knob counterclockwise (to the left).

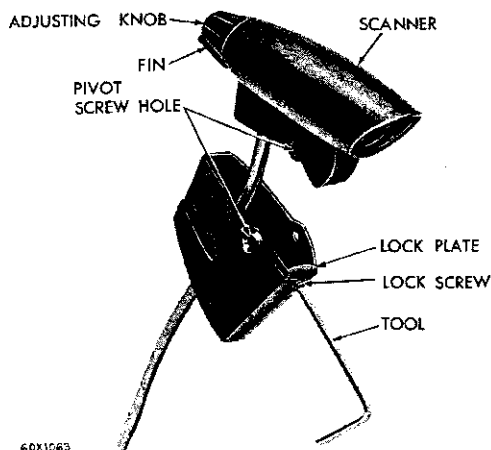

Fig. 16—Scanner Assembly

### 18. AIMING THE AUTOMATIC BEAM CHANGER

Pre-aiming instructions—Before attempting to aim the automatic beam changer, complete the following: Place the vehicle on a level floor. Measure the front spring height. Adjust to specifications, if necessary. Check tire inflation. Tire pressure should not vary more than 3-5 pounds. Rock the vehicle sideways to allow the spring shackles and other suspension parts to assume their normal position. If the fuel tank is not full, place an equivalent weight in the trunk of

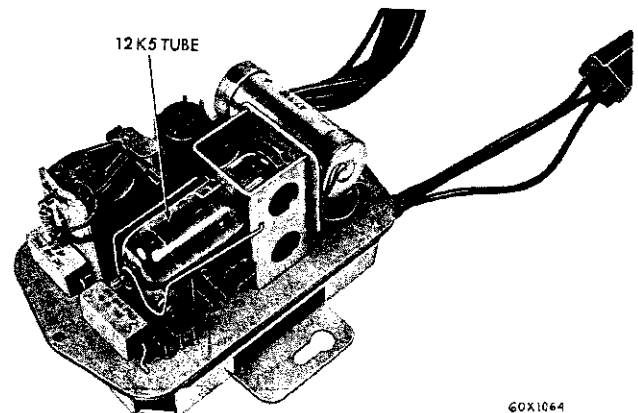

Fig. 17—Scanner Control Box Assembly

vehicle. There should be no other load in the vehicle, other than the driver.

### 19. AIMING THE SCANNER

Mount the "scanner" aimer leveling Tool C-3697, on the "scanner" unit, as shown in Figure 18. Make certain that all conditions listed under "pre-aiming instructions" have been met, before proceeding with the aiming operation.

Loosen the phillips head pivot locking screw (Fig. 1), just enough to permit free movement of the "scanner" through its arc, as controlled by the mounting base. (Total angular deflection of the "scanner" unit is 14 degrees).

Pivot the "scanner" forward or backwards on the base (through arc) until the leveler assumes a level position. Tighten the pivot and locking screws.

### 20. SCANNER UNIT

#### Removal

- (1) Disconnect the battery.
- (2) Disconnect the feed wires.
- (3) Remove the pivot and locking screws.
- (4) Remove the scanner assembly.

#### Installation

- (1) Mount the scanner to scanner base.
- (2) Install the pivot and locking screw.
- (3) Connect the feed wires.
- (4) Connect the battery.
- (5) Perform the operations listed under "Aiming of Scanner".

### 21. CONTROL UNIT

#### Removal

- (1) Disconnect the battery.
- (2) Disconnect the control box wires at the connectors.
- (3) Remove the control box attaching screws.
- (4) Remove the control box assembly.

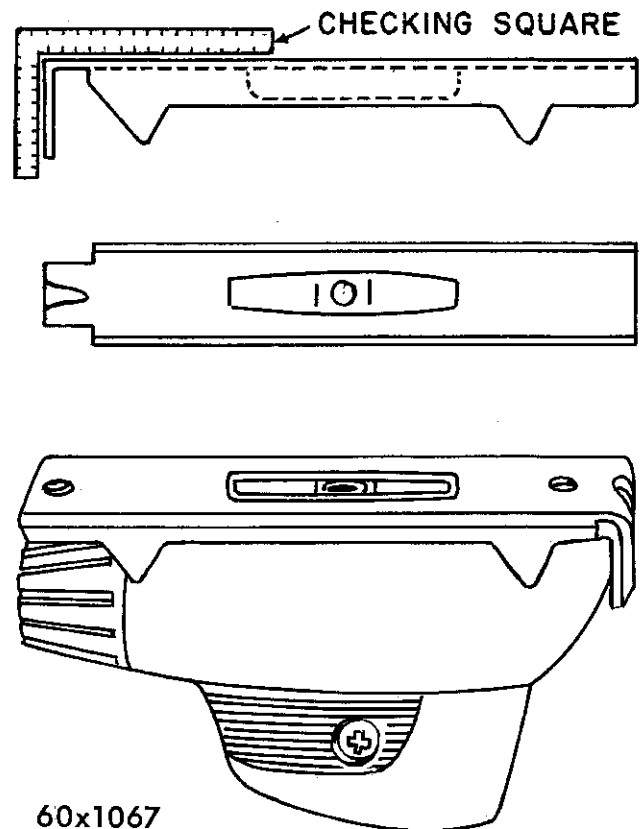

Fig. 18—Scanner Leveling Tool

#### Installation

- (1) Clean the area around the body where the control box spacer is attached to the dash panel to obtain proper metal to metal ground.
- (2) Mount the control box assembly to the body and install the attaching screws.
- (3) Connect the control box wires to the connectors.
- (4) Connect the battery.

## MIRRO-MATIC ELECTRONIC REAR VIEW MIRROR

The electronically operated mirror-matic rear view mirror, as shown in Figure 19, is a self-dimming automatic device which provides maximum rearward vision at night. The electronic glare detecting and mirror actuating mechanism is housed entirely within the mirror assembly (Fig. 20). The automatic tripping mechanism is a tiny photo-electric cell which "sees" through a small aperture in the silvered mirror sur-

face. As long as glare is present, the mirror will remain in its "dim" position, returning immediately to its normal "bright" position when the glare drops below a preset level.

The sensitivity of the sensing device is easily adjusted, to cause the automatic controls to actuate the mirror at whatever light intensity the driver finds most satisfactory.

**SERVICE PROCEDURES**

**22. DRIVER ADJUSTMENT (Positioning Mirror)**

When adjusting the position of the mirror-matic for best visibility, the headlights must be turned off to prevent the headlight circuit from energizing the photo-electric cell and creating a false reading.

An adjustment wheel (Fig. 19) protruding from the bottom of the mirror assembly is marked with an "off" position and numbered through the turning range from "one" to "ten", with number "three" "six" and "ten" detented to facilitate adjustment by feel.

The adjustment wheel must be turned "counter-clockwise" to reach the "off" position on the wheel. When the mirror is set at the number "three" notch (normal city driving), the mirror will be actuated by low beams from an overtaking car within approximately 80 feet. When the mirror is set at the number "six" notch (normal highway driving) the beams will be actuated within 250 feet, when set at the number "ten" notch the beam will be effective at 400 to 500 feet.

**23. REMOVAL AND DISASSEMBLY**

(1) Remove the mirror assembly from the attaching pedestal.

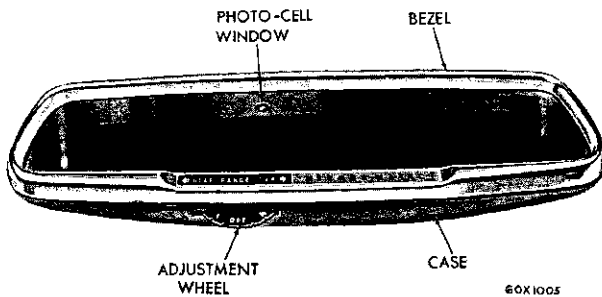

**Fig. 19—Electronic Rear View Mirror**

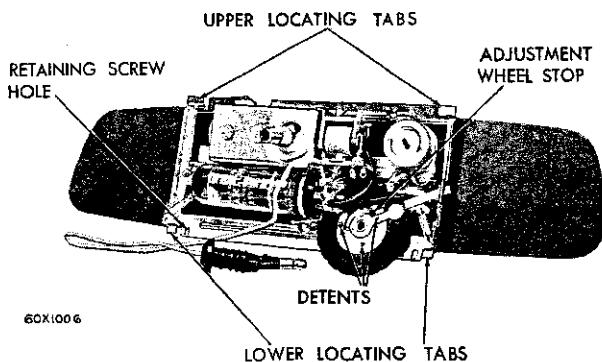

**Fig. 20—Mirror Actuating Mechanism**

(2) Carefully pull the bezel from the case assembly.  
 (3) Locate the ball joint in the down position towards the adjustment wheel.

(4) Bend the top of the case upwards to disengage each of the upper tabs from the case retaining grooves (Fig. 21).

(5) Press on the ball joint extension so as to tip the mirror assembly out of case.

(6) Pivot the adjusting wheel in the slot of the case until the upper part of the electronic chassis is outside of the upper forward edge of the case.

**24. INSPECTION AND TROUBLE SHOOTING**

**Before Disassembly**

In case the mirror does not function properly the following inspection operations should be performed:

- (1) Test the fuse and replace if necessary.
- (2) Inspect the lead wire, ground and other connections to make sure current is flowing to the mirror.

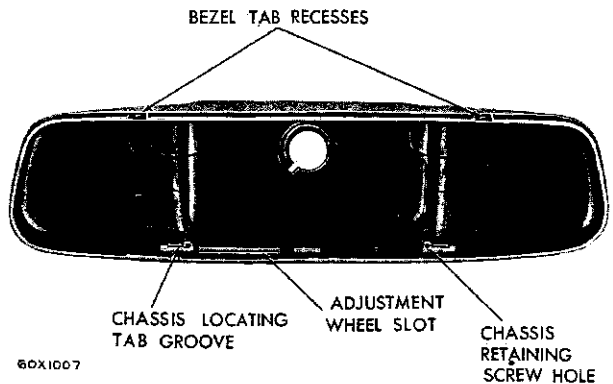

**Fig. 21—Locating the Grooves**

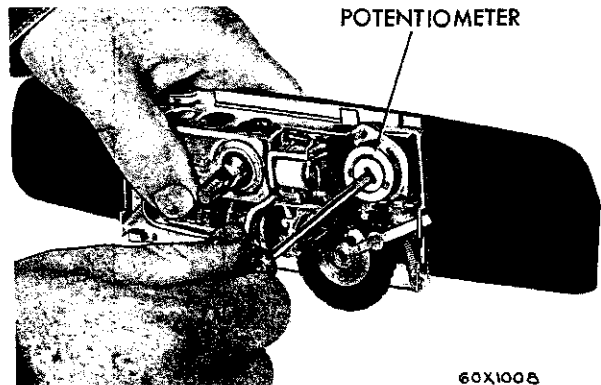

**Fig. 22—Adjusting the Potentiometer**

(3) Note the flip angle of mirror through which the image moves, when the mirror is actuated by sighting at some object through the rear window while actuating the mirror. If the image changes position when mirror is actuated the flip angle is incorrect.

#### After Disassembly

(1) Measure the spring load on the mirror chassis using a spring scale. Attach the scale to the chassis at the photo cell opening. Hold the assembly firmly and measure the spring load. The spring load should be at least 8 ounces. If less than 8 ounces the tension can be increased by shortening the two return springs at the lower corner of the chassis assembly.

**NOTE:** The small coil spring located on top of the relay along side the potentiometer should not be tampered with since this spring is pre-set to specific dimensions.

(2) If the sensitivity was incorrect, adjust potentiometer by turning clockwise to increase, counter-clockwise to decrease (Fig. 22).

(3) If the flip angle was incorrect, bend the chassis top tab (Fig. 23) rear of the solenoid, toward the glass to reduce the flip angle or away from glass to increase the flip angle. Do not bend the tab more than **one or two degrees** or the solenoid will not operate properly.

(4) Should it be necessary to separate the glass from the chassis it can be done by releasing the chassis return springs and disengaging the mirror from the chassis pivots.

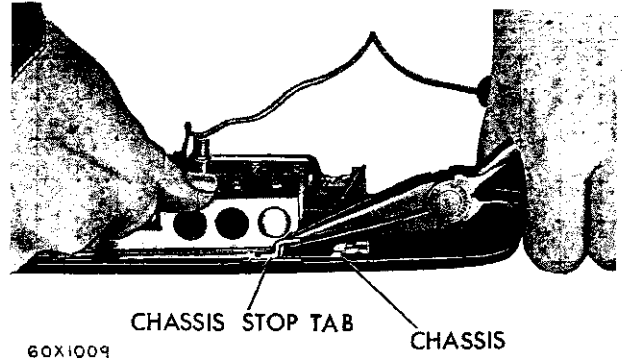

Fig. 23—Aligning the Chassis Tabs

## 25. REASSEMBLY AND INSTALLATION

(1) With the ball joint end in the down position install the lead wire through the hole in the rear of the case.

(2) Position the lower edge of the mirror in the case to allow for easy entrance to the adjustment wheel in the slot.

(3) Engage the chassis lower locating tabs in the case recess.

(4) Bend up the upper edges of the outer case slightly to allow for clearance of the upper locating tabs of the chassis.

(5) Assemble the mirror in case by slightly tipping the assembly.

(6) Engage the locating tabs in the case recesses.

(7) Install the bezel on the case.

## REMOTE CONTROL OUTSIDE MIRROR

The remote control outside mirror is controlled by stainless steel wires attached to wobble plates and a lever within the mirror assembly and is operated by a toggle lever located on the instrument panel

(Fig. 24). Adjustment of the mirror to meet driving requirements can be made without moving from the normal driving position.

## SERVICE PROCEDURES

### 26. REMOTE CONTROL MIRROR REPLACEMENT

#### Removal

- (1) Remove the toggle lever assembly bezel.
- (2) Remove the (2) screws attaching the mirror to the fender.
- (3) Remove the mirror, gasket, cable and lever assembly.

#### Installation

- (1) Install the gasket, mirror and cable assembly in the fender opening.
- (2) Route the cable and lever assembly up through the body to the instrument panel opening.
- (3) Attach the bezel to the cover assembly and tighten.
- (4) Test and adjust the operation of the mirror.

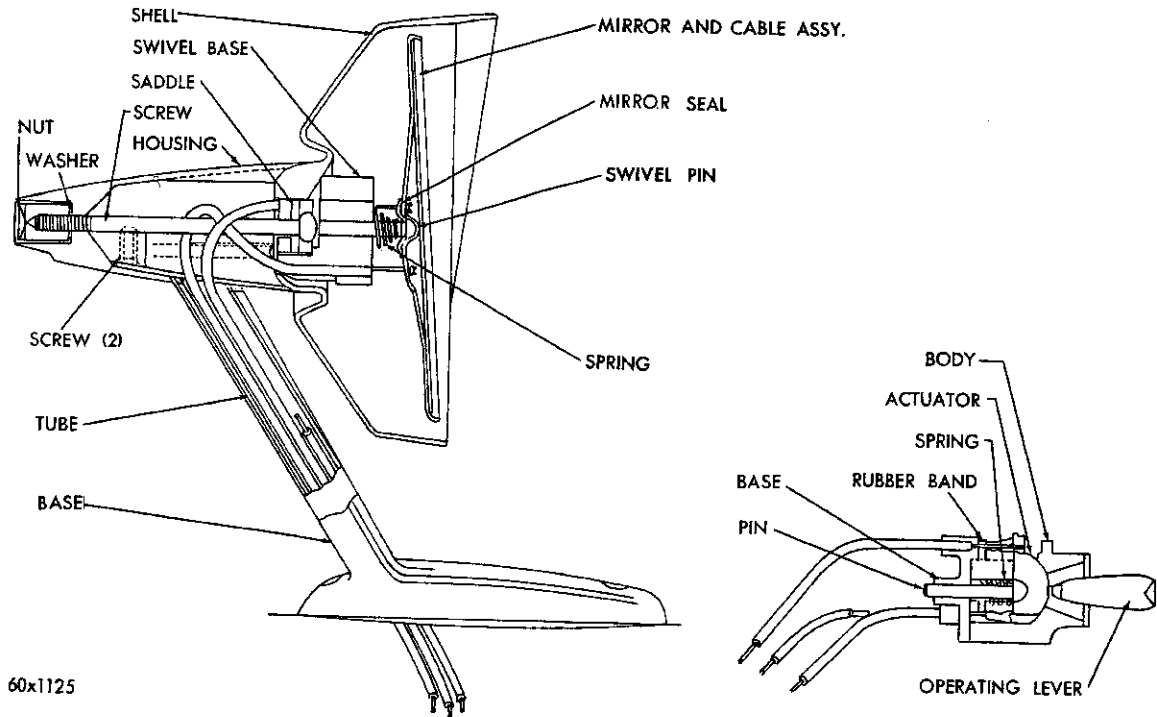

Fig. 24—Mirror Operating Lever

### ELECTRIC CLOCK

All models are equipped with a solenoid actuated self regulating clock. The clock can be regulated by pulling out the regulating stem below the clock

face and turning until the correct setting is accomplished.

### SERVICE PROCEDURES

#### 27. REMOVAL OF CLOCK

##### Removal (Chrysler)

- (1) Disconnect the battery ground cable.
- (2) Remove the instrument cluster from the instrument panel. (See "Electrical" Group 8—Instruments and Gauges).
- (3) Remove the reset knob from the clock.
- (4) Remove the wire connector from the terminal at the rear of the clock.
- (5) Remove the two screws attaching the clock to the instrument base and remove the clock.

##### Removal (Imperial)

- (1) Remove the three screws attaching the instrument cluster bezel to the instrument panel.
- (2) Pull the cluster forward from the instrument panel, just far enough to allow for disconnecting of

the reset cable, clock wire and illumination wire. Remove the clock attaching screws.

#### 28. INSTALLATION OF CLOCK

##### Installation (Chrysler)

- (1) Position the clock on the instrument base and install the two retainer screws.
- (2) Connect the wire lead to the terminal at the rear of the clock.
- (3) Install the clock reset knob.
- (4) Install the instrument cluster assembly.
- (5) Connect the battery ground cable and reset the clock.

##### Installation (Imperial)

- (1) Install the clock and retainer screws.
- (2) Install the reset cable, clockwire, and lamp wire.
- (3) Install the instrument cluster bezel screws.



## WINDSHIELD WASHER

The electrically-operated windshield washer is standard equipment on all Chrysler and Imperial models.

It is located on the engine side of the radiator support at the lower right corner (Fig. 25). This unit is a permanent magnet type motor, coupled to a plastic gear pump that supplies fluid through rubber tubing to dual nozzle jets mounted in the fresh air intake grille of the cowl ventilator. The motor is a permanently lubricated sealed unit and needs no servicing. A circuit breaker in the unit protects the motor from overheating in the event of continuous operation or stalling of the pump. The pump and motor are serviced as an assembly only.

### 29. OPERATION

Depressing a small button in the center of the windshield wiper knob actuates the motor and pump and a continuous stream of fluid is ejected as long as the button is depressed and fluid remains in the reservoir. The windshield washer operates independently of the windshield wipers.

### 30. TWO GEAR PUMP

A plastic bag type reservoir is mounted directly above the pump and the fluid is gravity fed from the bottom of the bag directly to the plastic two gear pump. The pump is a sealed unit and needs no service.

The outlet of the pump is attached by a rubber tubing to dual adjustable brass nozzles. Adjustment of the nozzle may be made by inserting a small screwdriver into the opening of the grill and rotating the nozzle in the direction of the spray as desired.

### 31. WINDSHIELD WASHER NOZZLE ADJUSTMENT

Adjust the nozzles so that fluid contacts the windshield at the top of the wiper pattern 13 inches from the windshield center line.

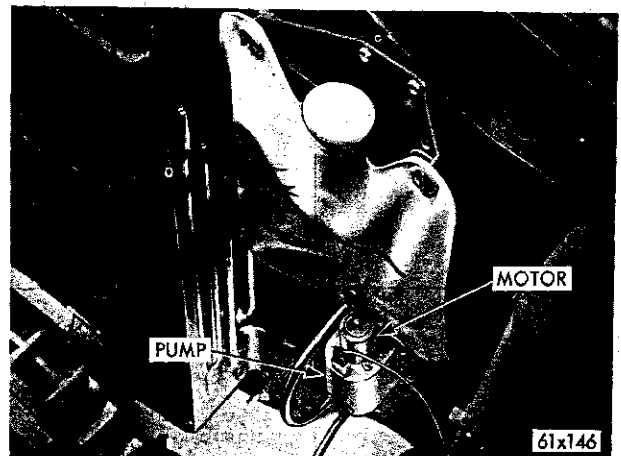

Fig. 25—Windshield Washer

## AUTO-PILOT

The auto-pilot (Fig. 1) is a driver operated voluntary speed control. It can be used either as a warning signal to indicate that a pre-set vehicle speed has been reached, or as a fully automatic vehicle speed regulator. In either operation it helps to reduce driver fatigue, contribute to highway safety, and improve fuel economy.

### Speed Warning Operation

A convenient dial selector knob located on the dash is used to set the auto-pilot to the desired speed the driver selects for the existing driving conditions. When the car reaches the preset speed, the auto-pilot provides a reaction pressure to the accelerator pedal pressure. Since the reaction pressure is five to seven pounds, the driver can exceed this speed by pressing the accelerator pedal through the reaction pressure and obtain the desired additional speed.

### Automatic Operation

With the selector knob set to the desired speed, and the button in the center of the knob pulled out, the

driver can accelerate the car to the speed where the reaction pressure is felt and the auto-pilot will engage itself. Then relaxing the accelerator pedal pressure, the auto-pilot will be in automatic regulation of the accelerator. The accelerator will automatically advance on uphill and retard on down grade operation. Automatic control ceases instantly with the slightest brake pedal movement and the accelerator will revert to manual control. Disengagement of the automatic control may also be accomplished by pushing "IN" the center button of the selector knob or turning the ignition switch to "OFF".

### Lubrication

Internal working parts of the auto-pilot are equipped with self-lubricated bearings, shielded ball bearings, or have been factory lubricated for the service life of the unit. When any internal service is performed, the drive screw worm (Fig. 26) and compressor rod should be lubricated lightly with MoPar lubricate.

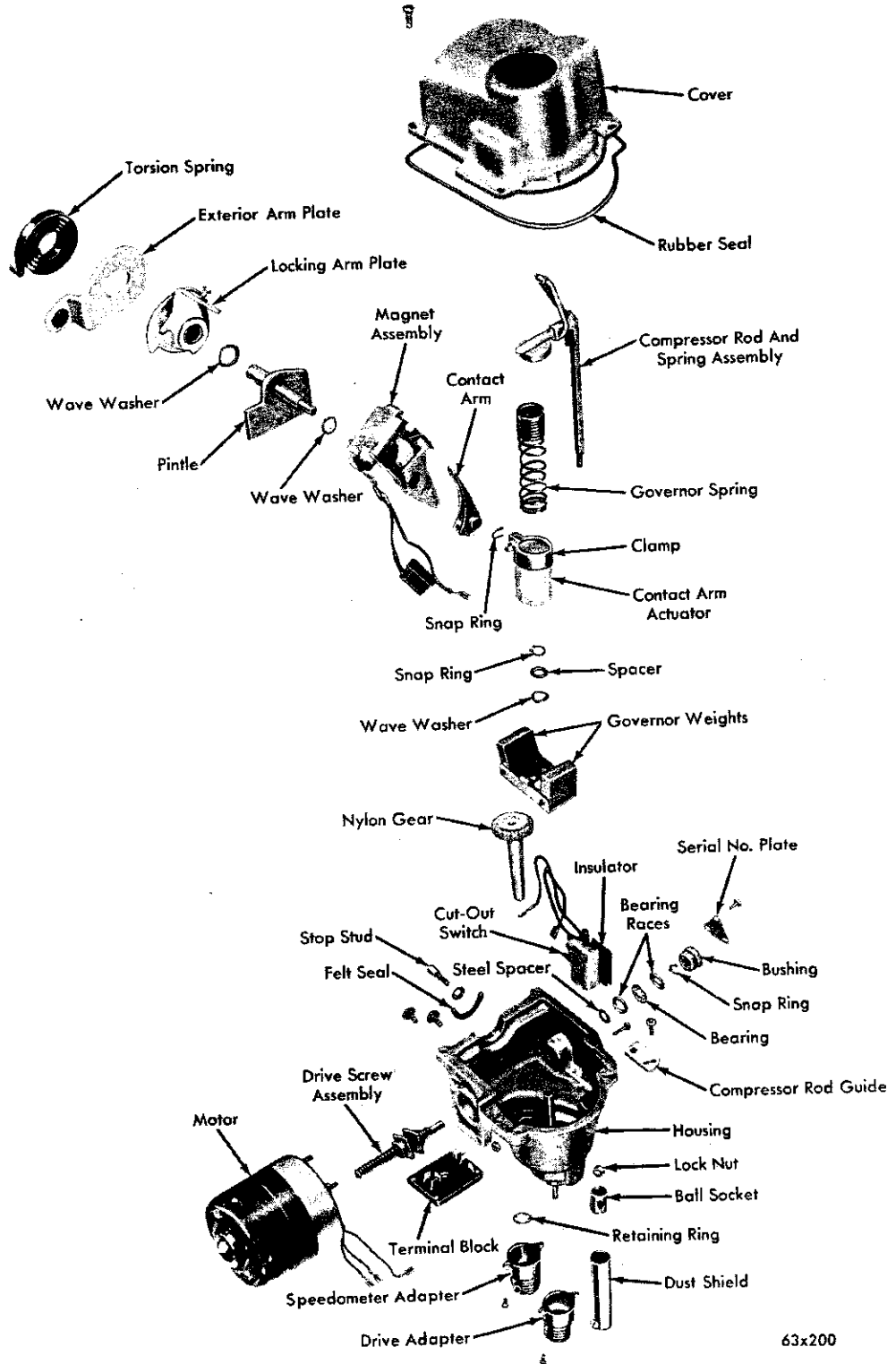

63x200

Fig. 26—Auto-Pilot (Disassembled View)

## SERVICE PROCEDURES

### 32. TESTS

The following mechanical and electrical tests will aid in isolating and correcting the above conditions. Diagnosis and trouble shooting procedures must be followed to make certain that the trouble is in the unit itself, and not in some other component of the system.

#### Operational Test

- (1) Turn the ignition switch "on". **Do not start the engine.**
- (2) Move the selector dial to the lowest speed position.
- (3) Depress the accelerator pedal to the wide open position.
- (4) Depress lock-in button. If the accelerator pedal stays in the depressed position, the electrical circuit and the lock-in mechanism is operating properly.
- (5) Slowly depress the brake pedal. If the accelerator pedal returns to the idle position, the brake pedal switch is operating properly.
- (6) Repeat steps 3 and 4.
- (7) Turn off the ignition switch. If the accelerator pedal returns to the idle position, the ignition switch portion of the electrical circuit and latching mechanism is operating properly.

#### Electrical Tests (Motor Circuit, Cut-Out Circuit, and Grounding Circuit)

- (1) Turn the ignition switch "on". **Do not start the engine.**
- (2) Using a test lamp, ground one test lamp lead and touch the other end to terminal No. 1, (Fig. 27). The test lamp should light. If the lamp fails to light,

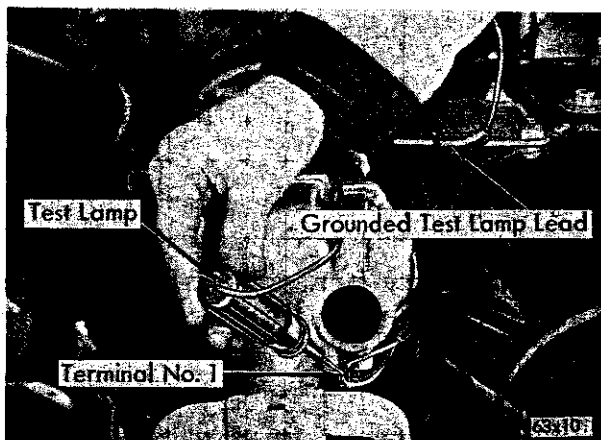

Fig. 27—Testing for Current at No. 1 Terminal

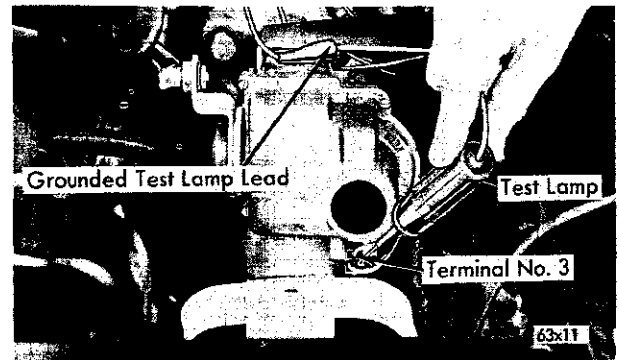

Fig. 28—Testing for Current at No. 3 Terminal

test for a blown fuse and test the entire motor circuit.

- (3) With one test lamp lead grounded, touch the other lead to terminal No. 2. The circuit is normal if the lamp lights. If the test lamp fails to light, make the following tests on the automatic cut-out circuit.

Test progressively along the circuit to the power unit, starting with the pink wire at the brake pedal switch. If the test lamp lights on the pink wire, test the orange wire. If the lamp does not light, the brake pedal is not in the release position or the switch is faulty.

- (4) If the test lamp lights at both terminals No. 1 and No. 2, test the ground circuit as follows:

Connect one end of the test lamp to terminal No. 1 and the other end to terminal No. 3 (Fig. 28) and depress the button on the selector control assembly. If the test lamp lights, the circuit and control are satisfactory. If the lamp does not light, test the wiring between the terminal No. 3 and the lock-in switch on the control by grounding the wire at the connector near control. If the test lamp now lights, test the ground wire for proper grounding at the cable housing and/or selector control plate assembly. Repair or replace as necessary.

- (5) Turn the ignition switch "off".

#### Testing Motor Operation

- (1) Turn the ignition switch "on". **Do not start the engine.**
- (2) Remove the four screws securing the power unit cover and remove the cover.
- (3) Test the accelerator linkage adjustment, as described in Paragraph 34.
- (4) Move the locking arm against the magnet and press down on the armature plate to latch the unit (simulating automatic control).

(5) Move the contact arm to touch contact point on the motor side of magnet. The motor should rotate the drive screw and open the throttle through the accelerator linkage.

(6) Move the contact arm to touch the contact point on the locking arm side of the magnet. The motor should rotate the drive screw and close the throttle through the accelerator linkage. If the motor will not open or close the throttle through the accelerator linkage, the motor may be binding. Check the alignment of the motor with the housing. To test the motor for binding, loosen the motor from the housing without disconnecting the motor leads and disengage the motor shaft from the drive screw. Move the contact arm against the contact point on the motor side of the magnet assembly to test reverse operation, and against the contact point on the locking arm side of the magnet assembly to test the forward operation. If the motor does not run free, replace the motor. If the motor does run free, stall test the motor as described in "Motor Stall Test".

The drive screw or carburetor linkage may also be binding. To test the drive screw for binding, disengage the motor shaft from the drive screw. Insert a screwdriver in the slotted end of the drive screw, and test for free rotation. If the drive screw does not rotate freely, it is faulty and should be replaced. If the motor and drive screw operates satisfactorily, then adjust the carburetor linkage.

(7) Turn the ignition switch "off", and install the power unit cover.

### **Motor Stall Test**

(1) Disconnect the multiple electric connector at the front of the power unit.

(2) Remove the four screws securing the power unit cover to the housing and remove the cover.

(3) Connect the red lead of an ammeter tester to the positive battery terminal.

(4) Insert the locking arm gauge Tool C-3844, over the stop stud to limit the travel of the locking arm and prevent rotation of the drive screw.

(5) Connect the black lead of the tester to No. 1 terminal on front of the power unit.

(6) Hold the contact arm against the contact point on the locking arm side of the magnet and observe the reading on the ammeter. If the reading on the ammeter indicates more than 7amps, the motor is drawing too much current and should be replaced.

(7) Disconnect the tester leads, remove the locking arm gauge, install the cover, and connect the multiple connector.

### **Testing for Damaged Cables and Gears**

(1) Raise the rear end of the vehicle until the rear wheels clear the floor.

(2) Start the engine and engage the transmission "D" button.

(3) Remove the speedometer cable at the power unit and see if the nylon gear is turning. This will determine if the cable from the transmission to the power unit is turning and if the gear is operating.

(4) If the nylon gear is turning, the cable to the speedometer is broken or the speedometer is inoperative.

(5) If the nylon gear is not turning, disconnect the transmission cable at the power unit.

(6) If the cable is turning, the gears are stripped inside the power unit.

(7) If the cable is not turning, test for a broken cable or a stripped transmission speedometer drive gear.

(8) Shut off the engine and lower the vehicle.

(9) Replace all necessary parts.

### **33. LOCKING ARM LATCH AND CONTACT POINT ADJUSTMENTS (ON THE VEHICLE)**

There are two sets of electrical contact points that operate the Auto-Pilot motor in the forward and reverse directions. One set of contact points, on the motor side of the magnet, controls the acceleration, while the contact point on the locking arm side of the magnet controls the deceleration. The points on the contact arm (one on each side) serve as the grounding points.

The contact points are still operative when blackened or pitted; however, any build-up on the points should be removed. When filing the points, **use a cloth to catch the filings as they could become wedged between the small ball bearings in the nut on the drive screw and cause the drive screw to stick.**

The locking arm latch must be properly adjusted before attempting to adjust the contact points. The point adjustment may be made at either set of contact points on the magnet assembly as a single adjustment takes care of both. The following procedure must be followed in the exact sequence:

#### **Locking Arm Latch Adjustment**

(1) Disconnect the multiple electrical connector at the front of the power unit.

(2) Disconnect the accelerator linkage rod from the exterior arm.

(3) Remove the four screws securing the power unit cover and remove the cover.

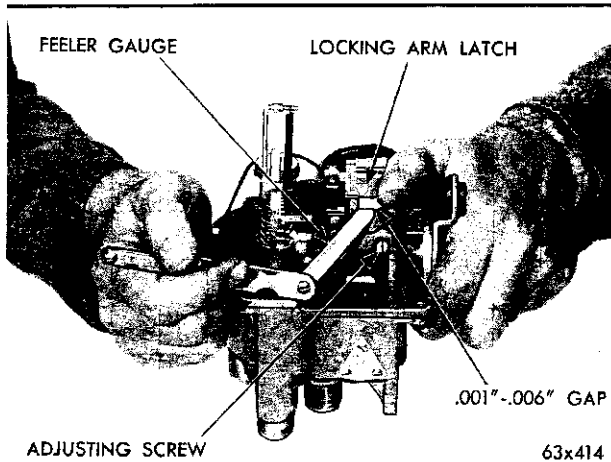

Fig. 29—Locking Arm Latch Adjustment

(4) Move the locking arm up against the magnet and press down on the armature plate to latch the unit (simulating automatic control).

(5) Use a feeler gauge to measure the gap between the locking arm and the latch on the armature plate (Fig. 29). This gap must be between .001-.006 inch. If the gap is not within specifications, adjust the gap by turning the adjusting screw counter-clockwise to increase the gap or clockwise to decrease the gap.

**Contact Point Adjustment**

(1) Disconnect the drive cable at the base of the power unit.

(2) Move the contact arm against either contact point and use a feeler gauge to measure the full gap between contact arm and other point (Fig. 30). This gap must be  $.090 \pm .010$  inch. If the gap is not within specifications, bend either contact point on the magnet assembly until the proper gap is obtained.

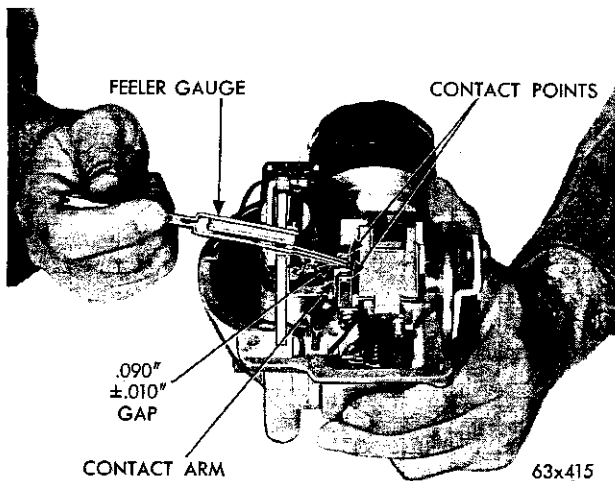

Fig. 30—Contact Point Adjustment (Full Gap)

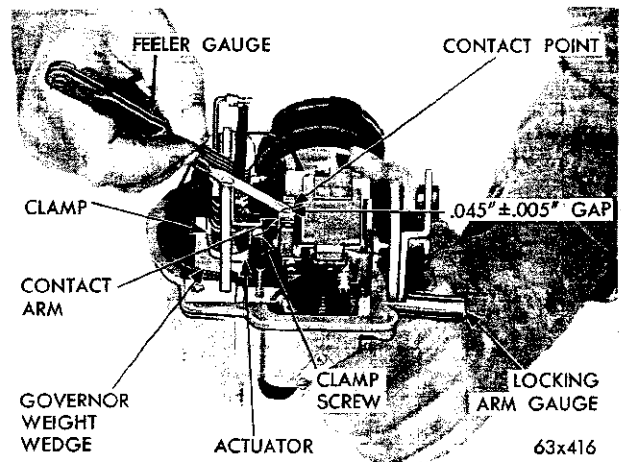

Fig. 31—Contact Point Adjustment (Contact Arm Centered)

(3) Insert the locking arm gauge Tool C-3844 over the stop stud. With a screw driver, move the magnet assembly to the low throttle position (against the locking arm). Turn the governor weights until they are parallel with the drive screw, then place the governor weight wedge Tool C-3842 between the governor weights, pressing down on the wedge until the weights are held out to their stop position.

(4) Use a feeler gauge to measure the gap between the contact arm and either contact point on the magnet assembly (Fig. 31). This gap should be approximately one-half of the full gap measurement outlined in Step 2. If the gap is not within the specifications, the contact arm is not centered properly. Loosen the screw on the actuator clamp (Fig. 31). Rotate the actuator until the contact arm is centered between the two contact points on the magnet assembly. Then tighten the clamp screw and measure the gap. When making adjustment for centering the contact arm, make certain the clamp is pressed down firmly against the actuator cams, otherwise, the clamp fingers will not follow the cam when the actuator is turned.

(5) Remove the locking arm gauge and governor weight wedge.

**34. LINKAGE ADJUSTMENT**

(1) Adjust the throttle control rod.

(2) Start the engine and operate at a slow idle.

(3) Remove the cotter pin securing the trunnion on the exterior arm plate, remove the washers, and separate the linkage from the exterior arm.

(4) Insert the locking arm gauge Tool C-3844 over the stop stud and hold the exterior arm securely against the gauge.

(5) Turn the trunnion until it aligns with and

enters the hole in the exterior arm freely. Due to the angle the trunnion enters the exterior arm, it is possible for the arm to be moved away from the gauge when the trunnion is inserted. Make certain the arm is still against the gauge after the trunnion is installed.

(6) Install the washers on the trunnion and secure the trunnion to the exterior arm with the cotter pin.

(7) Remove the gauge and shut off the engine.

### 35. CONTROL CABLE ADJUSTMENT

(1) Loosen the set screw on the end of the dust shield and work the control cable back and forth making certain the ferrule on the end of the cable is free to move when the dial is rotated.

(2) Rotate the selector dial backward to "Low" position, or as far as it will go without forcing it.

(3) Carefully insert the ferrule back into the dust shield without forcing it, until the ball socket just bottoms in the housing. **After positioning the ferrule in the dust shield, test the selector dial to be sure it is still in the extreme low speed position.**

(4) Tighten the set screw securely on the end of the dust shield. **Be careful not to change cable position when tightening set screw.**

### 36. SELECTOR CONTROL ASSEMBLY REPLACEMENT

#### Removal of the Selector Control Assembly (Chrysler):

(1) Disconnect the control cable from bottom of the Auto-Pilot by removing the clamp nut and dust shield, and unhook the ball on the end of the wire from the ball socket. (Fig. 32).

(2) Loosen the Allen screw in the selector knob

and pull button knob. Remove both knobs from the shaft.

(3) Disconnect the double plug connected to the wire harness.

(4) Unscrew the attaching nut. Remove the selector head from the instrument panel.

(5) Pull the cable through the dash panel from the passenger side.

#### Removal of the Selector Control Assembly (Imperial):

(1) Repeat steps (1), (2), (3) under "Removal of the Selector Control Assembly (Chrysler)".

(2) Unscrew the attaching nut.

(3) Remove the steering column lower dust shield.

(4) Remove the steering column clamp.

(5) Lower the steering column.

(6) Disconnect the double plug connected to the wiring harness.

(7) Pull the cable through the dash panel from the passenger side.

#### Installation of the Selector Control Assembly (Chrysler):

(1) Route the control cable through the dash panel from the passenger side.

(2) Install the selector head in instrument panel.

(3) Connect the ground wire and double plug.

(4) Install the attaching nut.

(5) Install the selector knob and the dial shaft and tighten the set screw.

(6) Install the pull button knob on the shaft and tighten the set screw.

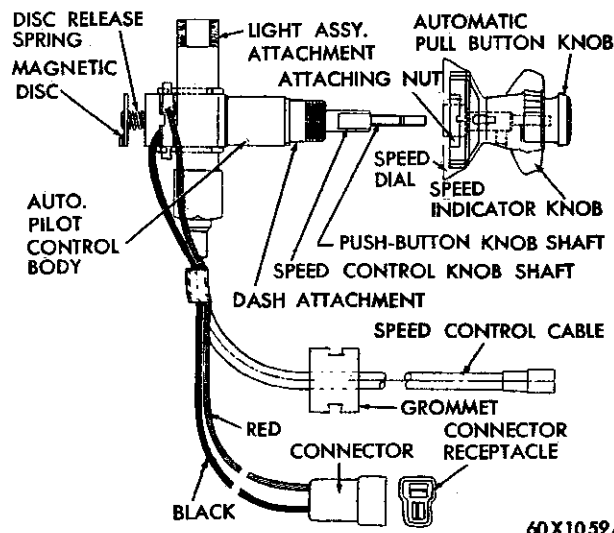

60X1059A

60 x 1059A

Fig. 32—Auto-Pilot Selector Control Assembly

(7) Connect the control cable to the Auto-Pilot unit. Adjust the control cable as described under Paragraph "Control Cable Adjustments".

#### **Installation of the Selector Control Assembly (Imperial):**

- (1) Route the control cable through the dash panel from the passenger side.
- (2) Install the selector head in steering column.
- (3) Connect the ground wire and double plug.
- (4) Install the attaching nut.
- (5) Install the selector knob and the dial on the shaft and tighten the set screw.
- (6) Install the pull button knob on the shaft and tighten the set screw.
- (7) Raise the steering column into position and install the steering column clamp. Tighten the clamp nuts.
- (8) Install the steering column lower dust shield.
- (9) Connect the control cable to the Auto-Pilot unit. Adjust the control cable as described under Paragraph "Control Cable Adjustments".

### **37. SERVICING THE DRIVE MECHANISM**

#### **Removal**

- (1) Disconnect the multiple electronic connector at the power unit.
- (2) Disconnect the drive cable and the speedometer cable from the power unit.
- (3) Loosen the set screw at the lower end of the dust shield.
- (4) Remove the dust shield from the housing, then slide the dust shield down the cable and slip the ball end of the bowden cable out of the socket.
- (5) Disconnect the accelerator linkage from the exterior arm plate on the power unit.
- (6) Remove the two bolts securing the power unit to the mounting bracket and remove the power unit, leaving the mounting bracket attached to the fender dust shield.

#### **Disassembly**

- (1) Remove the four screws securing the cover and remove cover. **Use care not to lose rubber seal or felt seal in the cover groove.**
- (2) Disconnect the green motor wire from the terminal block. **Do not attempt to straighten terminal fitting, as it is angled to prevent shorting on the housing cover.**
- (3) Remove the governor spring.
- (4) Loosen the nut at the top of the ball socket and remove the ball socket from the end of the com-

pressor rod. Remove the compressor rod from the housing.

- (5) Remove the screw from the compressor rod guide and remove the rod guide from the housing.
  - (6) Disconnect the red and black motor wires at the bottom of the contact points.
  - (7) Disconnect the black wires from the upper and lower terminal on the side of the cut-out switch.
  - (8) Remove the two nuts securing the motor to the housing and remove the motor.
  - (9) Disconnect the double plug-in connector from the terminal block, and the wire and retaining clip from the lip of housing.
  - (10) Disconnect the cut-out switch lead from the double plug-in connector by inserting a small allen wrench in the end of the connector to depress the tang on the wire end.
  - (11) Remove the screw securing the terminal block to the housing and remove the terminal block.
  - (12) Remove the screw securing the cut-out switch to the housing and remove the switch and insulator.
  - (13) Disconnect the torsion spring from the exterior arm plate, and remove the spring and the exterior arm.
  - (14) Remove the locking arm stop stud and washer and the two pintle retaining screws and washers located under the locking arm.
  - (15) Lift the magnet and pintle assembly out of the housing, being careful not to lose the felt seal in the groove of housing.
  - (16) Lift the contact arm actuator off of the drive shaft.
  - (17) Remove the locking arm plate from the pintle shaft and remove the wave washer.
  - (18) Remove the snap ring from the end of the pintle shaft and remove the contact arm from the shaft. Discard the snap ring.
  - (19) Remove the pintle shaft from the magnet assembly and remove the wave washer from the shaft. **Do not remove the switch on the magnet assembly, as it is not serviceable.**
  - (20) Remove the three screws from the serial number plate and remove the plate and bushing.
  - (21) Remove the snap ring, outer bearing race, bearing, inner bearing race and steel spacer. Remove the drive screw and nut from the motor end of the housing.
- CAUTION: When handling the drive screw assembly, keep parts clean, as dirt particles can become wedged between the small ball bearings on the end of the shaft or in the shaft nut and cause the drive screw to stick.**

(22) Remove the snap ring, spacer, wave washer, and governor weight assembly from the drive shaft inside the housing.

(23) Remove the two screws securing the speedometer adapter to the housing and remove the adapter.

(24) Remove the retaining ring securing nylon gear in the housing and remove the nylon gear.

(25) Remove the two screws securing the drive adapter to the housing and remove the adapter if necessary.

**NOTE: The governor assembly and power unit housing are serviced as a single unit.**

### Assembly

(1) Install drive adapter on the bottom of the power unit. **The drive adapter and speedometer adapter are interchangeable.**

(2) Lubricate the nylon gear with cam and bearing lubricant, and install the gear in the housing.

(3) Secure the gear in the housing with the retaining ring.

(4) Replace the speedometer adapter and secure with two screws.

(5) Install the governor weight assembly, wave washer, and spacer on the drive shaft. Install a new snap ring.

(6) Lubricate the drive screw assembly sparingly with cam and bearing lubricant and install through the motor end of housing.

(7) Insert the end of the drive screw through the boss in the housing and install the steel spacer, inner bearing race, bearing, outer bearing race, and a new snap ring on the end of the drive screw.

(8) Insert the bushing in the opening in the housing and install the serial number plate.

(9) Install the small wave washer on the pintle shaft and insert the pintle in the magnet assembly, through the side opposite the points.

(10) Install the contact arm on the end of the pintle shaft with the actuator pin facing away from the magnet. Install a new snap ring.

(11) Install the large wave washer on the pintle shaft and install the locking arm on the pintle.

(12) Position the drive nut in the center of the drive screw.

(13) Attach the actuator and clamp assembly on the contact arm and install the complete assembly into the housing, positioning the actuator over the governor shaft, and align the bracket tangs on the bottom of the magnet assembly with the grooves in the drive screw nut. Press down on the complete

assembly until it seats itself in the housing.

(14) Install the two pintle screws and lockwashers securing the magnet and pintle assembly in the housing.

(15) Install the locking arm stop stud and lock washer.

(16) Install the exterior arm on the locking arm shaft with the throttle arm toward the serial number plate.

(17) Install the torsion spring on the exterior arm. Using needle nose pliers, tighten the spring one complete turn before connecting it to the stud on the arm.

(18) Install the cut-out switch and insulator on the housing.

(19) Install the terminal block on the housing with the numbered connector blades outboard of the housing.

(20) Install the cut-out switch lead in the double plug-in connector. Plug the double plug-in connector onto the terminal block and secure the lead to the inside top edge on the housing with the retaining clip.

(21) Route the black wire from the switch on the magnet assembly, under the pintle shaft, and connect to the upper terminal on the side of the cut-out switch.

(22) Route the black wire from the top of cut-out switch, under the pintle shaft, loop back over the pintle shaft and connect to the bottom of the contact point on the locking arm side of the magnet.

**CAUTION: Be careful when routing wires so they will not come into contact with any moving parts.**

(23) Install the motor on the housing, threading the wires through the upper hole in the housing. Make certain that the end of the motor shaft engages in the slot of the drive screw. Install the motor mounting nuts and tighten the nuts securely. **Do not tighten by using screw driver on slotted bolt heads, as this may result in binding of the motor bearings.**

(24) Route black motor wire under the pintle shaft between the legs of the magnet assembly, and connect the wire to the lower terminal on the side of the cut-out switch.

(25) Route the red motor wire under the pintle shaft, loop back over the pintle shaft and connect the wire at the bottom of the contact point on the motor side of the magnet.

(26) Connect the green motor wire to the single connector on the terminal block. **Do not attempt to straighten terminal fitting, as it is angled to prevent shorting on the housing cover.**

(27) Install the compressor rod guide on the housing.



(28) Lubricate the compressor rod with cam and bearing lubricant. Install the compressor rod through the guide into the housing, and install the lock nut on the threaded end of the compressor rod. Install the governor spring in the actuator.

(29) Move the locking arm up against the magnet and press down on the armature plate to latch the unit, (simulating automatic control). Use a feeler gauge to measure the gap between the locking arm and the latch on the armature plate (Fig. 29). This gap must be between .001-.006 inch. If the gap is not within the specifications, adjust the gap by turning the adjusting screw counter-clockwise to increase the gap or clockwise to decrease the gap.

(30) Release the locking arm.

(31) Move the contact arm against either contact point and use a feeler gauge to measure the gap between the contact arm and the other point (Fig. 30). This gap must be  $.090 \pm .010$  inch. If the gap is not within specifications, bend either contact point on the magnet assembly until the proper gap is obtained.

(32) Insert locking arm gauge Tool C-3844 over the stop stud. Move the magnet assembly to the low speed position (magnet away from the motor). Turn the governor weights until they are parallel with the drive screw, then place governor weight wedge, Tool C-3842, between governor weights, pressing down lightly on the wedge and actuator until the weights are held out to their stop position.

(33) Use a feeler gauge to measure the gap between the contact arm and either contact point on the magnet assembly (Fig. 31). This gap should be approximately one-half of the full gap measurement listed in Step 31. If the gap is not within the specifications, the contact arm is not centered properly. Loosen the screw on the actuator clamp (Fig. 31) and rotate the actuator until the contact arm is centered between the two contact points on the magnet assembly. Then tighten the clamp screw and recheck the gap.

(34) Remove the locking arm gauge and governor weight wedge.

(35) Turn the drive screw to move the magnet assembly all the way toward the motor side of the housing to avoid any contact between the contact arm and the contact point on the motor side of the magnet. This must be done to prevent preloading of the governor spring by the contact arm before adjusting the compressor rod.

(36) Hold the housing in an upright position, and adjust the locknut until the spring seat on the compressor rod just rests on the governor spring without exerting pressure against the spring. Install the ball socket on compressor rod until it touches the locknut, then loosen the ball socket one complete turn and tighten the locknut. This will provide the correct low speed calibration for the power unit.

(37) Install the cover, making certain the rubber seal and felt seal are properly seated in the grooves of the cover and housing. Secure the cover with the four screws.

### Installation

(1) Position the power unit on the mounting bracket and secure to the bracket with two bolts.

(2) Connect the accelerator linkage to the locking arm on the power unit. Adjust linkage, as described in Paragraph 34.

(3) Install ball end of the bowden cable in the socket on the power unit.

(4) Install the dust shield in the housing. Push in and turn clockwise. Do not tighten the set screw on the end of the dust shield until the control cable is properly adjusted.

(5) Adjust the control cable, as described in Paragraph 35.

(6) Connect the drive cable and the speedometer cable to the power unit.

(7) Connect the multiple electric connector at the power unit.

## SERVICE DIAGNOSIS RADIO

Condition	Possible Cause	Correction
<b>38. Radio is Inoperative</b>	(a) Blown fuse.	(a) Replace the fuse.
	(b) Broken, loose or shorted antenna lead-in.	(b) Test with an auxiliary antenna and replace lead-in if necessary.
	(c) Loose battery cable.	(c) Test the voltage at the fuse and tighten all connections.
	(d) Faulty speaker.	(d) Replace the speaker.
	(e) Faulty antenna.	(e) Test the antenna and repair.

**SERVICE DIAGNOSIS**  
**RADIO—(Continued)**

Condition	Possible Cause	Correction
<b>39. Radio Reception is Weak</b>	(a) Unbalanced antenna trimmer.	(a) Adjust the antenna trimmer.
	(b) Loose antenna lead-in.	(b) Tighten the antenna lead-in.
	(c) Shorted antenna lead-in.	(c) Test with an auxiliary antenna and replace lead-in if necessary.
	(d) Faulty antenna.	(d) Test the antenna and correct.
<b>40. Radio Reception is Noisy (Engine Running)</b>	(a) Outside electrical interferences.	(a) Move the car or shut off interference.
	(b) Insufficient or faulty radio suppressors.	(b) Install suppressors in ignition system.
<b>41. Radio Reception is Noisy (Car in Motion)</b>	(a) Static build up in tires.	(a) Ground the tires to the wheels with powdered graphite.
	(b) Loose antenna or lead-in wire.	(b) Tighten the antenna attaching nut. Inspect the fit of the antenna lead-in plug in the socket.
<b>42. Radio is Noisy When Equipment is Operated</b>	(a) Loose antenna ground.	(a) Clean and tighten the antenna connections.
<b>43. Radio Reception is Distorted</b>	(a) Speaker coil rubbing on voice core.	(a) Install an auxiliary speaker and compare. Replace if improved.
	(b) Torn speaker cone.	(b) Replace the speaker.
<b>44. Search Tuner Runs Continuously</b>	(a) Car located in a weak signal area.	(a) Move the car to a strong signal area.
	(b) Faulty radio tube.	(b) Test and replace any faulty tubes.
<b>45. Intermittent Reception</b>	(a) Broken lead-in wire.	(a) Test with a substitute antenna. Repair the lead-in wire.
	(b) Grounded lead-in wire.	(b) Test with a substitute antenna. Repair the lead-in wire or replace.

**HEATER**

<b>46. Insufficient Heat</b>	(a) Coolant too low.	(a) Fill the radiator.
	(b) Temperature valve not opening.	(b) Inspect the valve and repair as needed.
	(c) Engine thermostat open.	(c) Replace the thermostat.
	(d) Damaged vacuum line to shut off damper.	(d) Replace the vacuum line.
	(e) Obstructed heater hose.	(e) Replace the heater hose.
	(f) Leaking lower radiator hose.	(f) Correct the leak, and bleed the system.
<b>47. Too Much Heat</b>	(a) Temperature valve stuck in open position.	(a) Free up the temperature valve and cable.
	(b) Disengaged cable.	(b) Connect or replace the cable.
	(c) Thermostat stuck in closed position.	(c) Replace the thermostat.
	(d) Damaged vacuum line to damper.	(d) Replace the vacuum line to damper.

**SERVICE DIAGNOSIS  
HEATER— ( Continued )**

Condition	Possible Cause	Correction
<b>48. Blower Motor Not Operating</b>	(a) Blown fuse.	(a) Replace the fuse.
	(b) Faulty electrical connection.	(b) Tighten all electrical connections.
	(c) Faulty blower switch.	(c) Replace the blower switch.
	(d) Faulty motor.	(d) Replace the motor.

**AUTOMATIC BEAM CHANGER**

<b>49. Unit Not Operating</b>	(a) Poor grounding of control units.	(a) Clean and tighten all control units.
	(b) Electrical circuit not properly wired.	(b) Trace the schematic diagram.
	(c) Faulty dimmer switch.	(c) Replace the dimmer switch.
	(d) Faulty tube.	(d) Replace the tube.
	(e) Faulty scanner.	(e) Replace the scanner.
	(f) Faulty control units.	(f) Replace the faulty control units.
	(g) Improperly focused scanner unit.	(g) Focus the scanner unit.
	(h) Loose cover screws.	(h) Tighten the cover screws as they also ground the unit.
<b>50. Tube Not Lighted</b>	(a) Faulty dimmer switch.	(a) Replace the dimmer switch.
	(b) Poor grounding of control units.	(b) Remove, clean and reinstall the control units.
	(c) Faulty tube.	(c) Replace the faulty tube.
	(d) Poor electrical connection.	(d) Clean and tighten all electrical connections.

**ELECTRONIC REAR VIEW MIRROR**

<b>51. Mirror Does Not Tilt</b>	(a) Broken wire or loose connection.	(a) Trace wiring and clean and lighten <b>all</b> electrical connections.
	(b) Burned out tube or transistor.	(b) Test the tube and transistor and replace if defective.
	(c) Mirror not grounded.	(c) Clean and tighten the mirror and attaching screws.
<b>52. Flip Angle Inadequate or Excessive</b>	(a) Chassis stop tab angle incorrect.	(a) Bend the stop tab to proper position.
<b>53. Tube Does Not Light</b>	(a) Low battery voltage.	(a) Recharge the battery.
	(b) Faulty tube.	(b) Test and replace if weak.
	(c) Broken circuit.	(c) Test the circuit for open leads and repair.
<b>54. Sensitivity Not Within Specified Limits</b>	(a) Potentiometer out of adjustment.	(a) Recalibrate the potentiometer.
	(b) Possible difference of sensitivity of a new tube on replacement.	(b) Test and compare several new tubes and select a tube within specifications.

**REMOTE CONTROL OUTSIDE MIRROR**

<b>55. Unable to Adjust Mirror</b>	(a) Control cables twisted.	(a) Loosen main cable assembly and realign for free operation.
	(b) Cable or cables broken.	(b) Replace mirror assembly.

## SERVICE DIAGNOSIS

## CLOCK

Condition	Possible Cause	Correction
56. Clock Does Not Operate	(a) Wire connector not on clock terminal.	(a) Connect wire to terminal.
	(b) Internal short.	(b) Remove clock and repair as necessary.

## ELECTRIC WINDSHIELD WASHER

57. Motor Does Not Run	(a) Loose wiring terminals.	(a) Tighten the terminals.
	(b) Corroded terminals.	(b) Clean and tighten the terminals.
	(c) Broken wires.	(c) Replace the wires.
	(d) Faulty switch.	(d) Replace the switch.
	(e) Shorted motor.	(e) Replace the assembly.
	(f) Poor ground.	(f) Clean the housing and tighten.
58. Fluid From Only One Nozzle	(a) Dirt in the nozzle.	(a) Blow out the nozzle with compressed air.
	(b) Broken or torn hose.	(b) Replace the hose.
	(c) Pinched or kinked hose.	(c) Replace the hose.
	(d) Hose disconnected from nozzle.	(d) Install the hose on the nozzle.
59. Pump Does Not Operate	(a) Motor does not operate.	(a) Replace the unit.
	(b) Broken coupling.	(b) Replace the unit.
	(c) Faulty pump.	(c) Replace the unit.
	(d) Reservoir dry.	(d) Fill the reservoir.

## AUTO PILOT

**NOTE: It is recommended that the diagnosis be performed in the sequence outlined. Do not disassemble the Auto-Pilot unit, or the control assembly, until all the diagnosis and adjustment operations are performed and it is proven beyond any doubt that the control assembly or Auto-Pilot unit is at fault.**

60. Speedometer Noise	(a) Cables bent or kinked.	(a) Straighten or replace the cables.
	(b) Lack of cable lubrication.	(b) Lubricate the cables.
	(c) Noisy speedometer head assembly.	(c) Remove and repair the speedometer.
	(d) Noisy nylon gear or metal drive gear.	(d) Replace the nylon gear or housing assembly.
61. Blowing Fuses	(a) Short or ground in wiring circuit.	(a) Test for short or ground. Repair or replace as required.
	(b) Locked drive screw.	(b) Inspect the drive screw for dirt or damage. Replace if necessary.
62. No Speed Control Response	(a) Accelerator linkage broken or disconnected.	(a) Connect or replace the linkage and adjust.
	(b) Drive cables broken or disconnected.	(b) Connect or replace the cables.
	(c) Damaged nylon gear or drive gear.	(c) Replace the nylon gear or the housing assembly.
	(d) Blown fuse.	(d) Replace and locate and correct the cause.
	(e) Loose connections or broken wires (internal and external).	(e) Test for current at the unit. Repair the wires or tighten the wiring connections as required.

**SERVICE DIAGNOSIS**  
**AUTO PILOT—(Continued)**

Condition	Possible Cause	Correction
<b>63. Constant Pressure on Accelerator Pedal Regardless of Selector Setting</b>	<ul style="list-style-type: none"> <li>(a) Blown fuse.</li> <li>(b) No current at #1 terminal.</li> <li>(c) Control cable improperly adjusted.</li> <li>(d) Inoperative motor or locked drive screw.</li> </ul>	<ul style="list-style-type: none"> <li>(a) Replace the fuse. Locate and correct the cause of blowing fuse.</li> <li>(b) Test for current at #1 terminal.</li> <li>(c) Properly adjust the cable.</li> <li>(d) Test the operation of motor. Correct as required. If the drive screw is locked, test the motor for possible damage.</li> </ul>
<b>64. Automatic Control Does Not Engage When Button is Pulled Out</b>	<ul style="list-style-type: none"> <li>(a) Driver riding the brake pedal. Driver does not hold accelerator against back pressure when pulling the button.</li> <li>(b) No current at the #2 terminal.</li> <li>(c) Loose or disconnected ground wire between the selector assembly and terminal #3.</li> <li>(d) Inoperative switch in the selector assembly.</li> <li>(e) Magnet assembly does not latch.</li> <li>(f) Inoperative magnet.</li> </ul>	<ul style="list-style-type: none"> <li>(a) Instruct the owner of Auto-Pilot operation and demonstrate.</li> <li>(b) Perform the electrical test and correct as required.</li> <li>(c) Tighten or connect the ground wire.</li> <li>(d) Test the switch and current at terminal #3.</li> <li>(e) Inspect and adjust the locking arm latch.</li> <li>(f) Replace the magnet assembly.</li> </ul>
<b>65. Automatic Selector Engages at Selected Speed Without Pulling Button Knob</b>	<ul style="list-style-type: none"> <li>(a) Ground wire (#3 to selector) is grounded.</li> <li>(b) Inoperative grounding switch in the selector assembly.</li> </ul>	<ul style="list-style-type: none"> <li>(a) Test for ground in the circuit and repair as required.</li> <li>(b) Test at terminal #3, and install a new control if necessary.</li> </ul>
<b>66. Automatic Control Remains Engaged When Brake Pedal is Touched</b>	<ul style="list-style-type: none"> <li>(a) Inoperative brake switch.</li> </ul>	<ul style="list-style-type: none"> <li>(a) Test at terminal #2. Adjust brake switch.</li> </ul>
<b>67. Pulsating Accelerator Pedal</b>	<ul style="list-style-type: none"> <li>(a) Speedometer cable or drive cable kinked.</li> <li>(b) Lack of lubrication.</li> <li>(c) Improper accelerator linkage adjustment.</li> <li>(d) Improper locking arm latch adjustment.</li> <li>(e) #1 and #2 contact points improperly adjusted.</li> </ul>	<ul style="list-style-type: none"> <li>(a) Straighten and align the cables. Replace if necessary.</li> <li>(b) Lubricate the cables.</li> <li>(c) Adjust the accelerator linkage properly.</li> <li>(d) Inspect and adjust the locking arm latch.</li> <li>(e) Inspect and adjust the point clearance.</li> </ul>
<b>68. Carburetor Does Not Return to Normal Idle</b>	<ul style="list-style-type: none"> <li>(a) Improper carburetor or accelerator linkage adjustment.</li> </ul>	<ul style="list-style-type: none"> <li>(a) Adjust the throttle control and accelerator linkage.</li> </ul>
<b>69. Speedometer Does Not Register or Unit Does Not Operate</b>	<ul style="list-style-type: none"> <li>(a) Speedometer drive pinion in the transmission damaged.</li> <li>(b) Broken speedometer cable.</li> <li>(c) Broken drive cable from transmission to the drive mechanism.</li> </ul>	<ul style="list-style-type: none"> <li>(a) Replace the speedometer drive pinion.</li> <li>(b) Replace the speedometer cable.</li> <li>(c) Replace the drive cable.</li> </ul>

**1-30 ACCESSORIES**

---

**SERVICE DIAGNOSIS**  
**AUTO PILOT—(Continued)**

---

<b>Condition</b>	<b>Possible Cause</b>	<b>Correction</b>
	(d) Faulty speedometer.	(d) Remove and repair the speedometer.
	(e) Damaged drive gear or nylon gear in the drive mechanism.	(e) Replace the nylon gear. If the metal drive gear is damaged, replace the housing assembly.

---