

GROUP 4 - BRAKE-PARKING

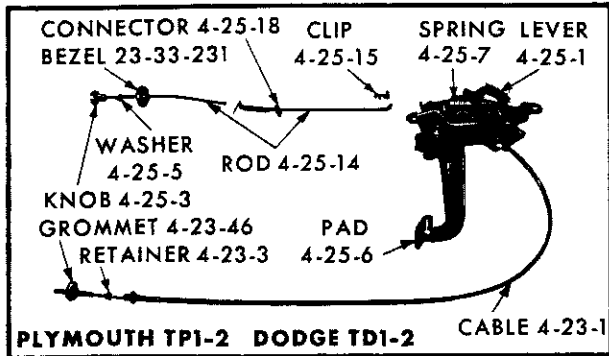

PARTS INDICATED BY NAME ONLY - ORDER BY DESCRIPTION

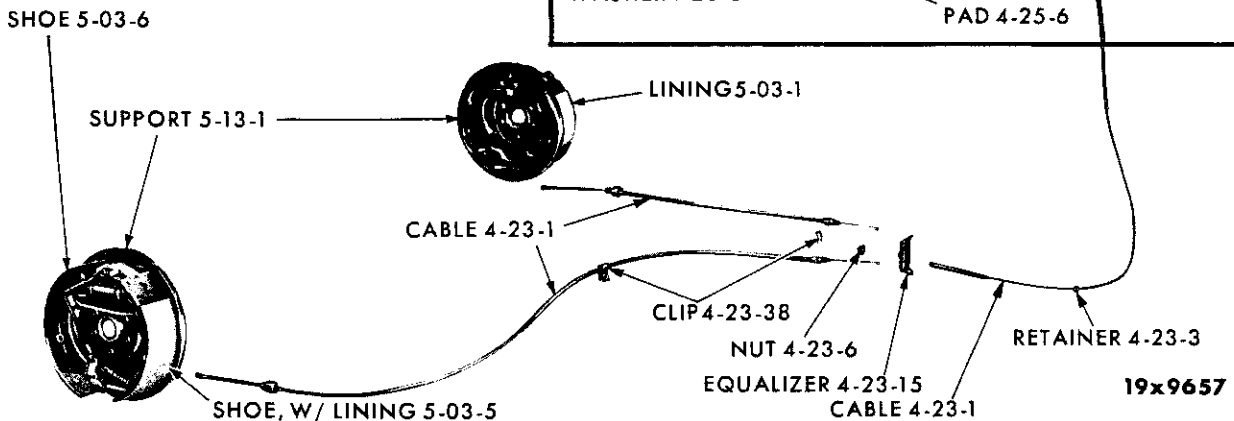

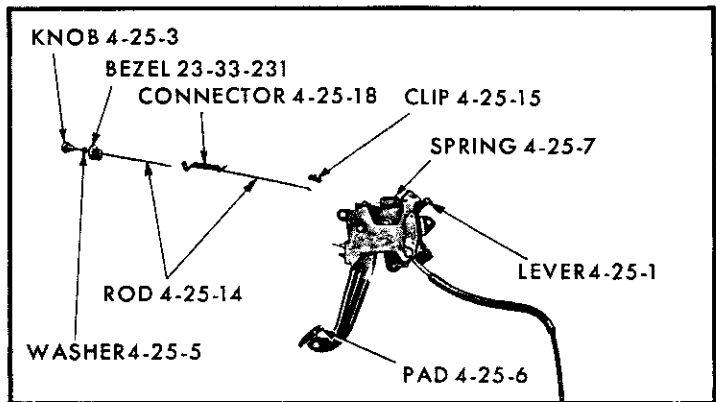
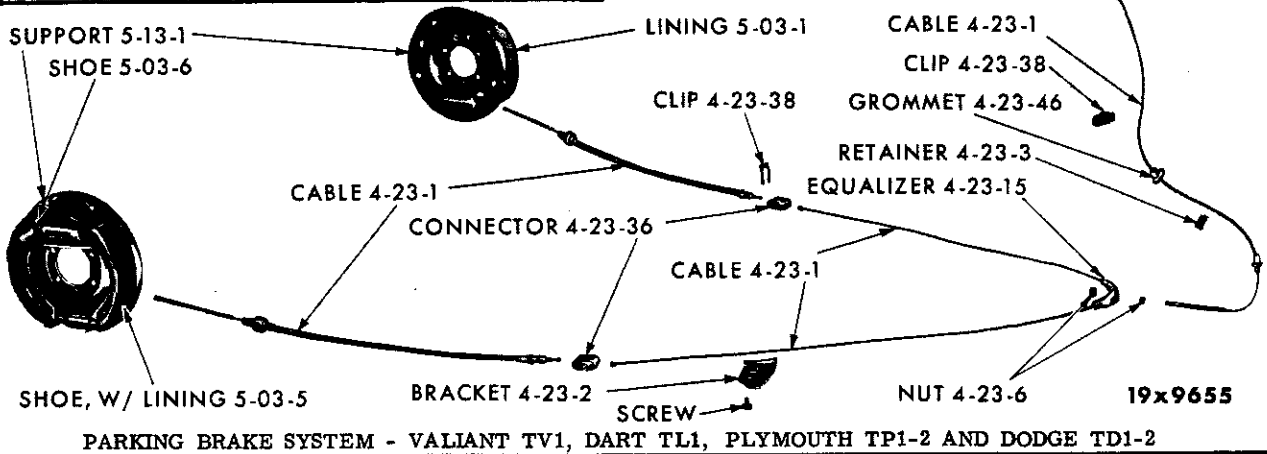
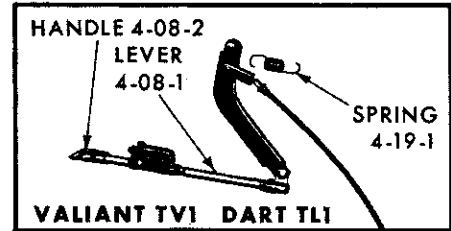
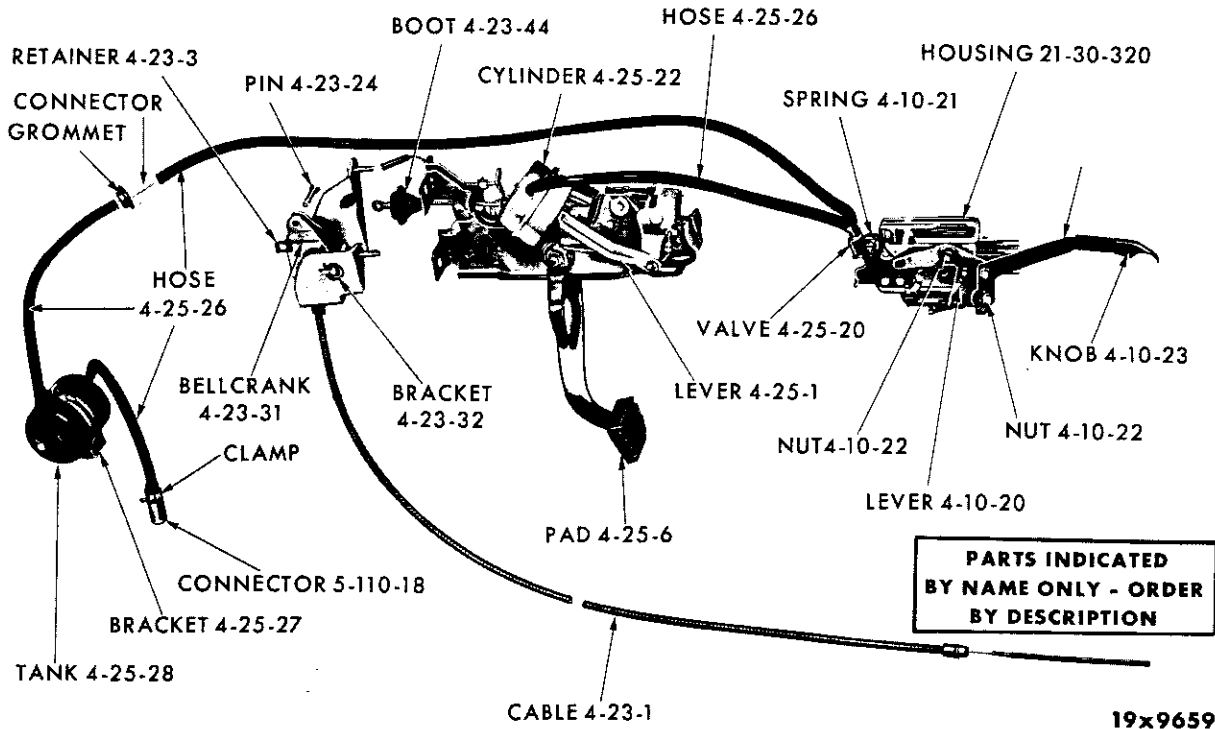

PARKING BRAKE VACUUM LINES - CHRYSLER TC3 LUXURY NEW YORKER AND IMPERIAL TY1

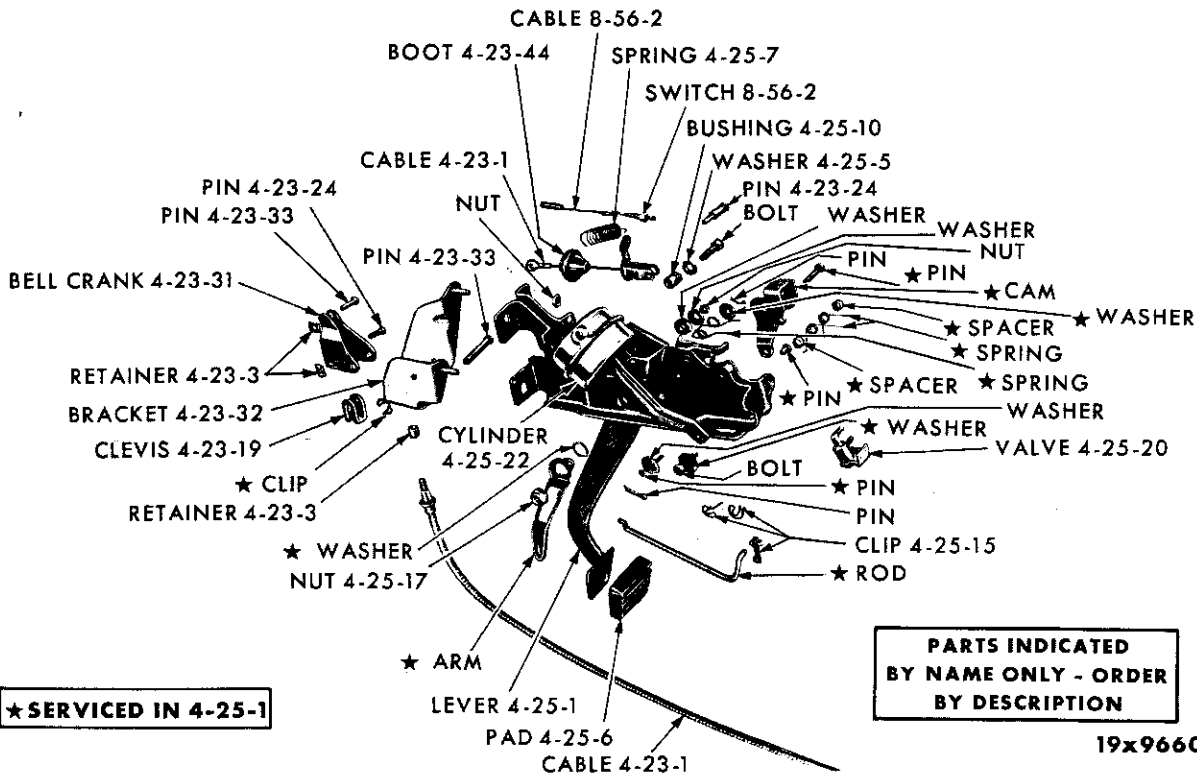

PARKING BRAKE CONTROLS (VACUUM RELEASE) - CHRYSLER TC3 LUXURY NEW YORKER AND IMPERIAL TY1

CODE	PART NAME AND DESCRIPTION	C Y L.	PER CAR	VALIANT DART	PLYMOUTH DODGE	CHRYSLER IMPERIAL
4-08-0 PARKING BRAKE LEVER (HAND OPERATED)						
4-08-1	LEVER		1	2265 300	2401 760	
4-08-2	HANDLE, Lever, Narrow, Plain		1	*1829 827		
	Wide, Marked "Brake"		1	*2409 450		
4-08-3	BRACKET, Lever Mounting		1	----	2401 302	
	Lever Hinge	6	1	2409 428		
4-08-8	PIN, Handle Stop		1	273 503	1405 532	
4-08-26	ANCHOR, Lever Return Spring		1	----	2265 324	
4-08-34	HINGE, Lever		1	----	2265 322	
4-08-35	PIN, Lever Hinge		1	1732 198	1732 198	
4-08-36	RETAINER, Lever Hinge Pin		1	1829 817	1829 817	
4-10-0 TRANSMISSION PARKING LOCK						
4-10-1	CABLE, TP1, TP2		1	2401 291	2401 291	
	TD1, TD2		1	----	2401 292	
	TA3	8	1	----	1942 256	1942 256
	TC2-300J	8	1	----	----	*2401 291
4-10-2	ADAPTER		1	1942 199	1942 199	1942 199
4-10-3	SPRING, Cable Adapter		1	1673 184	1673 184	1673 184
	Cable Actuator		1	1942 011	1942 011	1942 011
4-10-4	WASHER, Cable Adapter		1	1942 012	1942 012	1942 012
4-10-5	SCREW, Cable Clamp		1	2124 637	2124 637	2124 637
	LOCKWASHER		1	120 380	120 380	120 380
	NUT		1	120 367	120 367	120 367
4-10-7	LEVER, Sprag Operating		1	2124 589	2124 589	2124 589
4-10-8	SHAFT, Operating Lever, except Police and Taxi	6	1	1942 544	1942 544	
	Police and Taxi, TP1, TD1	6	1	----	1942 163	
		8	1	----	1942 163	1942 163
4-10-9	SPACER, Operating Lever		1	2124 588	2124 588	2124 588
4-10-10	SPRAG		1	1942 000	1942 000	1942 000
4-10-11	SPRING, Sprag		1	1942 161	1942 161	1942 161
4-10-12	BUSHING, Sprag		1	1942 162	1942 162	1942 162
4-10-15	COVER		1	2400 062	2400 062	2400 062
	SCREW		5	6022 230	6022 230	6022 230
4-10-16	GASKET, Cover		1	2205 207	2205 207	2205 207
4-10-17	ROLLER		1	1942 005	1942 005	1942 005
4-10-19	BEARING, Roller Needle		22	1942 006	1942 006	1942 006
4-10-20	LEVER, Sprag Control		1	2208 169	2208 169	2208 169
	ARM, Sprag Control Lever, TP1, TP2		1	2401 997	2260 855	
	TD1, TD2, TC1, TC2, TC3		1	----	2401 296	2265 199
	TA3, TY1	8	1	----	2405 222	2401 290
4-10-21	SPRING, Control Lever		1	2123 248	2123 248	2123 248

★ Indicates use as required. Numerals in parentheses () refer to notes. Printed in U.S.A.
 ☐ Indicates parts not listed in any previous parts book. Prices and specifications subject to change without notice.
 * Indicates change or addition. Jan. 3, 1964 Supersedes Dec. 14, 1962.

1963 PASSENGER CAR PARTS CATALOG

BRAKE-PARKING

CODE	PART NAME AND DESCRIPTION	CYL	PER CAR	VALIANT DART	PLYMOUTH DODGE	CHRYSLER IMPERIAL
4-10-O TRANSMISSION PARKING LOCK - Cont'd						
4-10-22	NUT, Control Lever		1	6023 118	6023 118	6023 118
	Control Lever Stud		2	6022 582	6022 582	6022 582
4-10-23	KNOB, Control Lever Arm, TP1, TP2		1	2266 422	2204 256	
	TD1, TD2, TA3, TC1, TC2, TC3		1	----	2258 884	2401 976
	TY1	8	1	----	----	2401 978
4-10-24	RIVET, Roller Shaft		1	2124 648	2124 648	2124 648
4-10-25	CLIP, Control Cable Bracket, TA3	8	1	----	2401 299	2401 299
	Control Lever Pin		1	6023 285	6023 285	6023 285
4-10-27	SEAL, Control Cable		1	1536 268	1536 268	1536 268
4-10-28	GROMMET, Control Cable, TP1, TP2, TD1, TD2 . .		1	2265 189	2265 190	
	TA3	8	1	----	2265 189	2265 189
4-13-O PARKING BRAKE LEVER PAWL						
4-13-6	PIN, Pawl Pivot		2	----	1405 533	
4-19-O PARKING BRAKE LEVER RETURN SPRING						
4-19-1	SPRING, Hand Operated		1	1556 693	1946 446	
4-23-O PARKING BRAKE CABLE						
4-23-1	CABLE, Front, Hand Operated		1	*2404 817	*2404 817	
	Foot Operated, TP1, TP2, TD1, TD2		1	----	2404 818	
	TA3, TC1, TC2, TC3	8	1	----	2404 819	2404 819
	TY1, Primary	8	1	----	----	2404 809
	TY1, Secondary, UP-TO	8	1	----	----	*2404 811(1)
	TY1, Secondary, AFTER	8	1	----	----	B2409 429(1)
	w/EQUALIZER, TV1, TL1 Sub.	6	1	2401 762		
	TL1 except Sub., TP1, TP2, TD1 Sub., TD2 Sub. .		1	2401 763	2401 763	
	TD1, TD2, except Sub., TY1		1	----	2401 764	2401 794
	Rear, TP1, TP2, TD1, TD2		2	*2448 768	*2448 768	
	Right, TA3, TC1, TC2, TC3	8	1	----	2401 797	2401 797
	Left, TA3, TC1, TC2, TC3	8	1	----	*2448 769	*2448 769
	TY1	8	2	----	----	*2448 769
4-23-2	BRACKET, Cable Guide, on Front Floor Pan. . . .		2	2259 028	2254 785	
	TA3, TC1, TC2, TC3	8	1	----	2424 162	2424 162
	Rear		1	2401 756	2259 028	
4-23-3	RETAINER, Front Cable, TC1, TC2, TC3		★	2071 132	1946 468	1946 468
	On Crossmember, TY1	8	1	----	----	2404 814
	At Bellcrank Bracket, TY1	8	1	----	----	2071 132
	Cable to Bellcrank Pin, TY1	8	2	----	----	2404 832
4-23-4	SEAL, Cable, on Floor Pan, TA3, TC1, TC2, TC3 .		1	----	2259 118	2259 118
4-23-6	NUT, Cable Equalizer Lock, TP1, TP2, TD1, TD2, TY1		1	2073 205	2073 205	2073 205
	TA3, TC1, TC2, TC3	8	1	----	6023 997	6023 997
4-23-7	SUPPORT, Cable, on Rear Side Rail, TC1, TC2, TC3		2	2251 398	2251 398	2251 398
4-23-15	EQUALIZER, Cable, TP1, TP2, TD1, TD2, TY1 . .		1	2073 134	2073 134	2073 134
	TA3, TC1, TC2, TC3	8	1	----	2401 768	2401 768
4-23-19	CLEVIS, Cable to Bellcrank, TY1	8	1	----	----	2404 829
4-23-24	PIN, Clevis, Upper, Hand Operated		1	2265 269	2265 269	
	Primary Cable, Front, TY1	8	1	----	----	2404 843
	Cable to Bellcrank, TY1	8	1	----	----	2404 834

NOTE 1: TY1 Approximate Serial No. 207949

★ Indicates use as required. Numerals in parentheses () refer to notes. Printed in U.S.A.
 ☐ Indicates parts not listed in any previous parts book. Prices and specifications subject to change without notice.
 Jan. 3, 1964 Supersedes Dec. 14, 1962. Page 4-4 * Indicates change or addition.

CODE	PART NAME AND DESCRIPTION	C Y L	PER CAR	VALIANT DART	PLYMOUTH DODGE	CHRYSLER IMPERIAL
4-23-O PARKING BRAKE CABLE - Cont'd						
4-23-28	CLAMP, Cable, Hand Operated		1	2265 273	2401 303	
4-23-31	BELLCRANK, Cable, TY1	8	1	-----	-----	2404 813
4-23-32	BRACKET, Cable Bellcrank, TY1	8	1	-----	-----	2404 806
4-23-33	PIN, Bellcrank Pivot, TY1	8	1	-----	-----	623 355
	Primary Cable to Bellcrank, TY1	8	1	-----	-----	2404 833
4-23-36	CONNECTOR, Cable, TP1, TP2, TD1, TD2, TY1		2	*2071 094	*2071 094	*2071 094
4-23-38	CLIP, Cable, TA3, TC1, TC2, TC3		1	2401 759	2409 195	2409 195
	Rear Support Bracket, TP1, TP2, TD1, TD2, TY1		2	*2401 300	*2401 300	*2401 300
	TA3, TC1, TC2, TC3	8	2	-----	2201 467	2201 467
4-23-44	BOOT, Front Primary Cable, TY1	8	1	-----	-----	2218 347
4-23-46	GROMMET, Cable, TP1, TP2, TD1, TD2.		1	2401 772	2401 772	
	TA3	8	1	-----	2216 552	2216 552
4-25-O PARKING BRAKE LEVER (FOOT OPERATED)						
4-25-1	LEVER, TP1, TP2, TD1, TD2		1	-----	2401 770	
	TA3, TC1, TC1, TC3	8	1	-----	2401 317	2401 317
	TC3, Luxury New Yorker	8	1	-----	-----	2409 176
	TY1	8	1	-----	-----	2401 790
4-25-2	BRACKET, Mounting, TY1	8	1	-----	-----	2080 568
	NUT, Lever Bracket Adjusting, TY1		1	-----	-----	*6023 950
	BOLT, Lever Bracket Adjusting, TY1		1	-----	-----	*9419 247
4-25-3	KNOB, Release, TP1, TP2, TC1, TC2, TC3		1	-----	2401 792	2401 329
	TD1, TD2, TA3		1	-----	2265 282	
4-25-4	SPRING, Cam Return, Right, TY1	8	1	-----	-----	*2404 845
	Left, TY1	8	1	-----	-----	*2404 804
4-25-5	WASHER, Release Knob, TC1, TC2, TC3.		1	-----	2265 296	2265 296
	Lever Silencing, TY1	8	1	-----	-----	2404 849
4-25-6	PAD, Pedal, TC1, TC2, TC3		1	-----	1946 401	2404 846
	TY1	8	1	-----	-----	*1946 434
4-25-7	SPRING, Pedal Return, TC1, TC2, TC3.		1	-----	2401 323	2401 323
	TC3 Luxury New Yorker	8	1	-----	-----	2409 188
	TY1		1	-----	-----	2208 043
4-25-9	BUMPER, Pedal Stop, TC1, TC2, TC3		1	-----	2071 150	2071 150
	TY1	8	1	-----	-----	2404 848
4-25-10	BUSHING, Pedal Pivot, TY1	8	1	-----	-----	2401 301
4-25-14	ROD, Release Lever, TP1, TP2, TD1, TD2		1	-----	2071 154	
	TA3, TC1, TC2, TC3	8	1	-----	2404 840	2404 840
	Release Knob, TP1, TP2, TD1, TD2		1	-----	2265 315	
	TA3, TC1, TC2, TC3	8	1	-----	2404 841	2404 839
4-25-15	CLIP, Release Rod, TC1, TC2, TC3		1	-----	6008 145	6008 145
	TY1	8	1	-----	-----	6008 144
	Release Cam, TY1	8	2	-----	-----	1137 669
4-25-17	NUT, Pedal Pivot, TC1, TC2, TC3		1	-----	1927 232	1927 232
	TY1	8	1	-----	-----	1940 596
4-25-18	CONNECTOR, Release Rod, TC1, TC2, TC3		1	-----	2265 316	2265 316
4-25-20	VALVE, Release, TC3 Luxury New Yorker, TY1	8	1	-----	-----	2260 945

★ Indicates use as required.

Numerals in parentheses () refer to notes.

Printed in U.S.A.

⊕ Indicates parts not listed in any previous parts book.

Prices and specifications subject to change without notice.

* Indicates change or addition.

Jan. 3, 1964 Supersedes Dec. 14, 1962.

1963 PASSENGER CAR PARTS CATALOG

BRAKE-PARKING

CODE	PART NAME AND DESCRIPTION	CYL.	PER CAR	VALIANT DART	PLYMOUTH DODGE	CHRYSLER IMPERIAL
4-25-O PARKING BRAKE LEVER (FOOT OPERATED) - Cont'd						
4-25-22	CYLINDER, Vacuum, TC3 Luxury New Yorker . . .	8	1	----	----	2409 179
	TY1	8	1	----	----	*2401 786
4-25-23	BEZEL, Pedal Pad, TA3, TC1, TC2, TC3	8	1	----	2404 847	2404 847
4-25-26	HOSE, Release Valve, TC3 Luxury New Yorker, TY1	8	★	----	----	2405 462
4-25-27	BRACKET, Release Valve Surge Tank, TC3 Luxury New Yorker, TY1.	8	1	----	----	2405 465
4-25-28	TANK PACKAGE, Release Valve Surge, TC3 New Yorker, TY1	8	1	----	----	2421 268
4-26-O PARKING BRAKE OPERATING LEVER						
4-26-1	LEVER, w/PIN, Right, 9" x 2" Brakes	6	1	2265 360		
	Left, 9" x 2" Brakes	6	1	2265 361		
	Right, 10" x 2 1/2" Brakes		1	----	2260 830	
	Left, 10" x 2 1/2" Brakes		1	----	2260 831	
	Right, 11" x 2 1/2" and 11" x 3" Brakes		1	----	2260 800	2260 800
	Left, 11" x 2 1/2" and 11" x 3" Brakes		1	----	2260 801	2260 801
4-26-17	STRUT, Lever	6	2	2072 689		
	10" x 2 1/2" Brakes, TP1, TP2, TD1, TD2 . . .		2	----	2260 423	
	11" x 2 1/2" Brakes, TP1, TP2, TD1, TD2, Heavy Duty, Police and Taxi, TA3, TC1, except Sub.		2	----	2260 557	2260 557
	11" x 3" Brakes, TA3, TC1, Sub., TA3, TC1, Police, TC2, TC3, TY1	8	2	----	2401 512	2401 512
4-26-18	SPRING, Strut.		2	2072 646	2260 807	2260 807
4-26-26	WASHER, Operating Lever Pin		2	2072 643	2072 643	2072 643
4-26-27	LOCK, Lever Pin Washer		2	2072 644	2072 644	2072 644

NOTES

★ Indicates use as required. Numerals in parentheses () refer to notes. Printed in U.S.A.
 ☒ Indicates parts not listed in any previous parts book. Prices and specifications subject to change without notice.
 Jan. 3, 1964 Supersedes Dec. 14, 1962. Page 4-6 * Indicates change or addition.