

GROUP 10 - ENGINE OILING

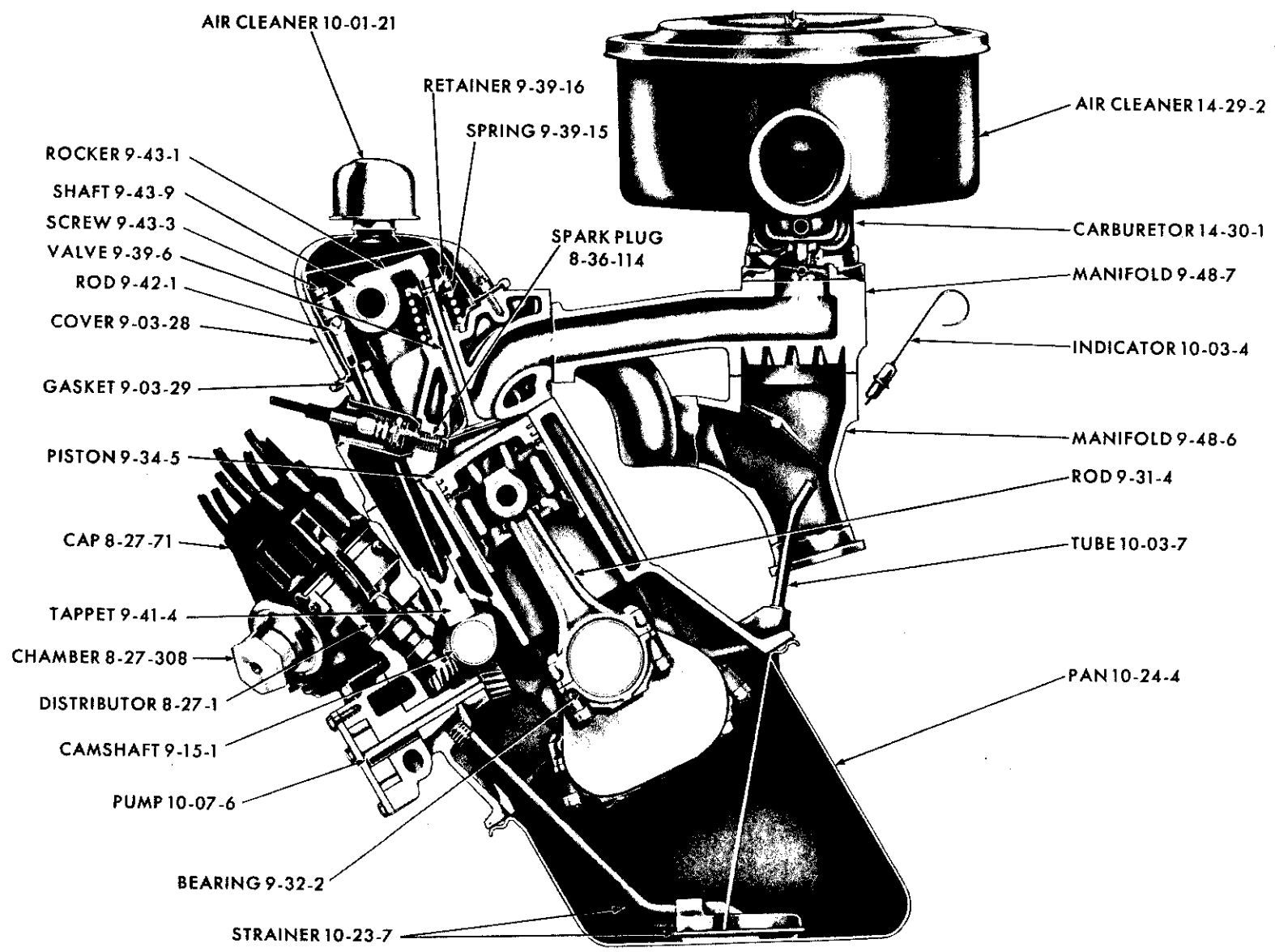

ENGINE OILING - 6 CYLINDER

19x8778

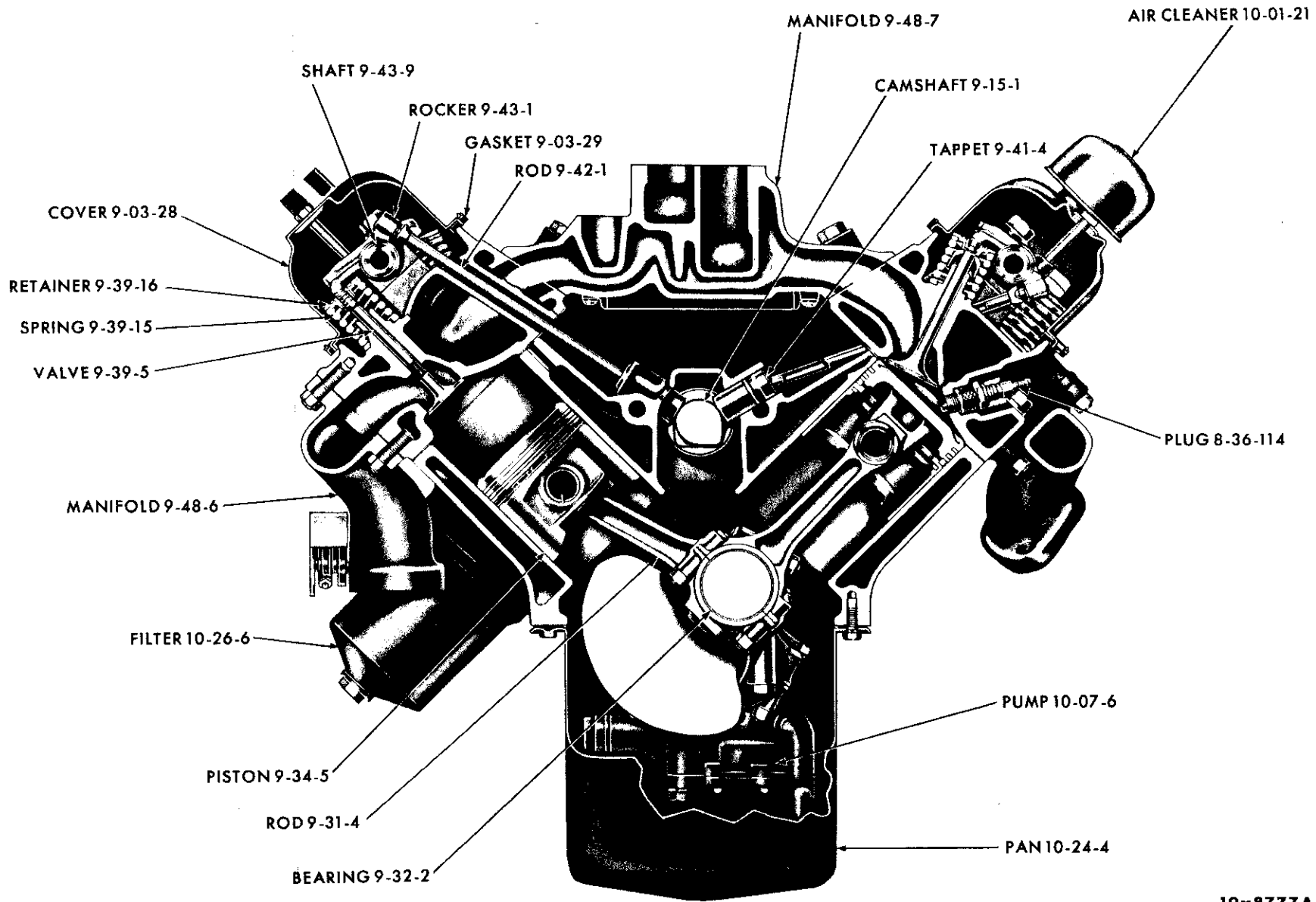

19x8777A

ENGINE OILING (V8 CYLINDER) - WITH 318 CU. IN. ENGINE

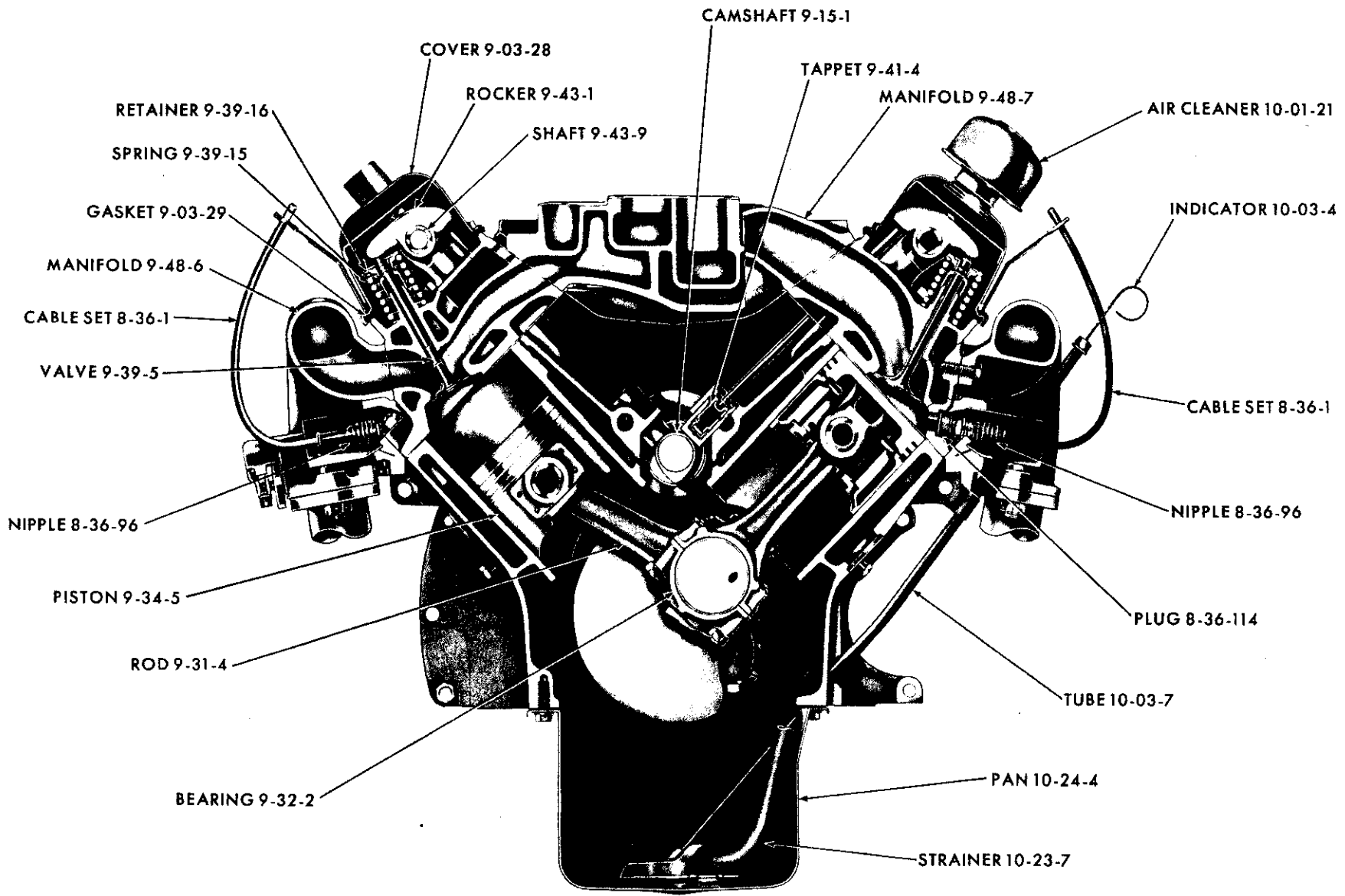

ENGINE OILING (V8 CYLINDER) - WITH 361, 383 AND 413 CU. IN. ENGINE

19x8776A

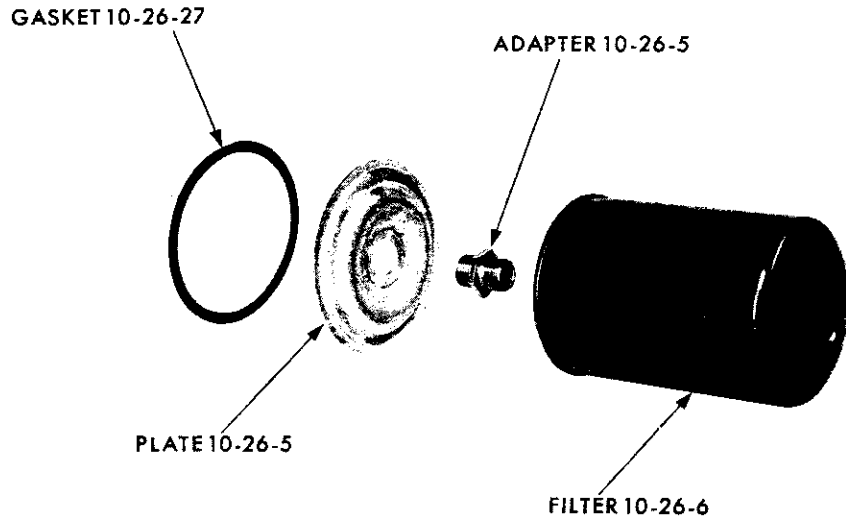

19x9489

OIL FILTER - 318 CU. IN. ENGINE

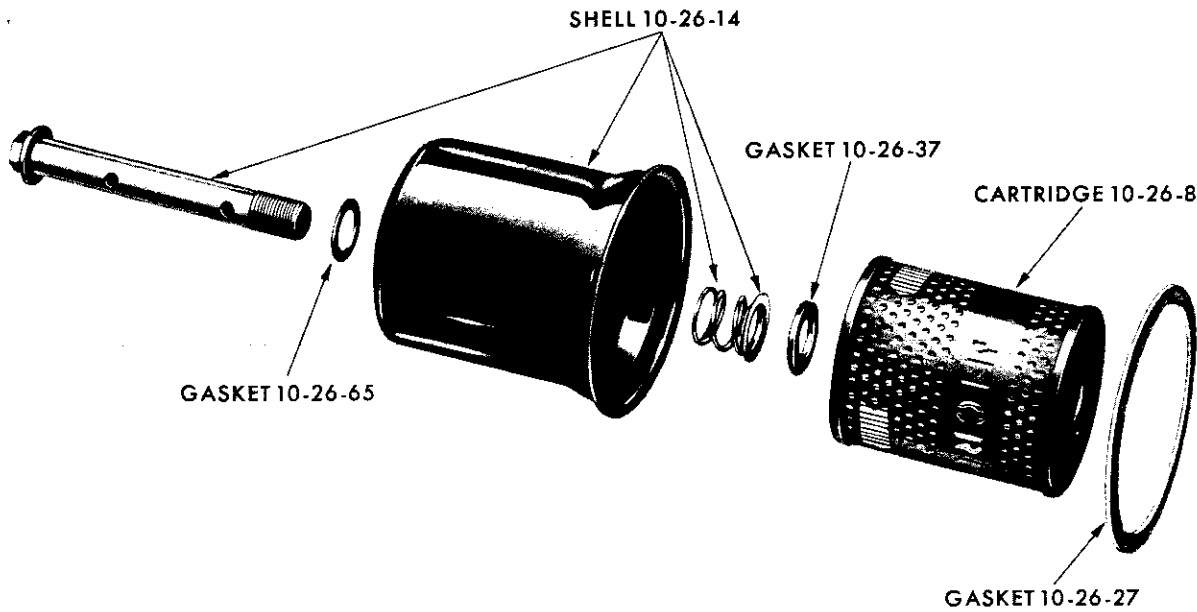

19x8591

OIL FILTER - WITH 318 CU. IN. ENGINE (REPLACEABLE CARTRIDGE TYPE)

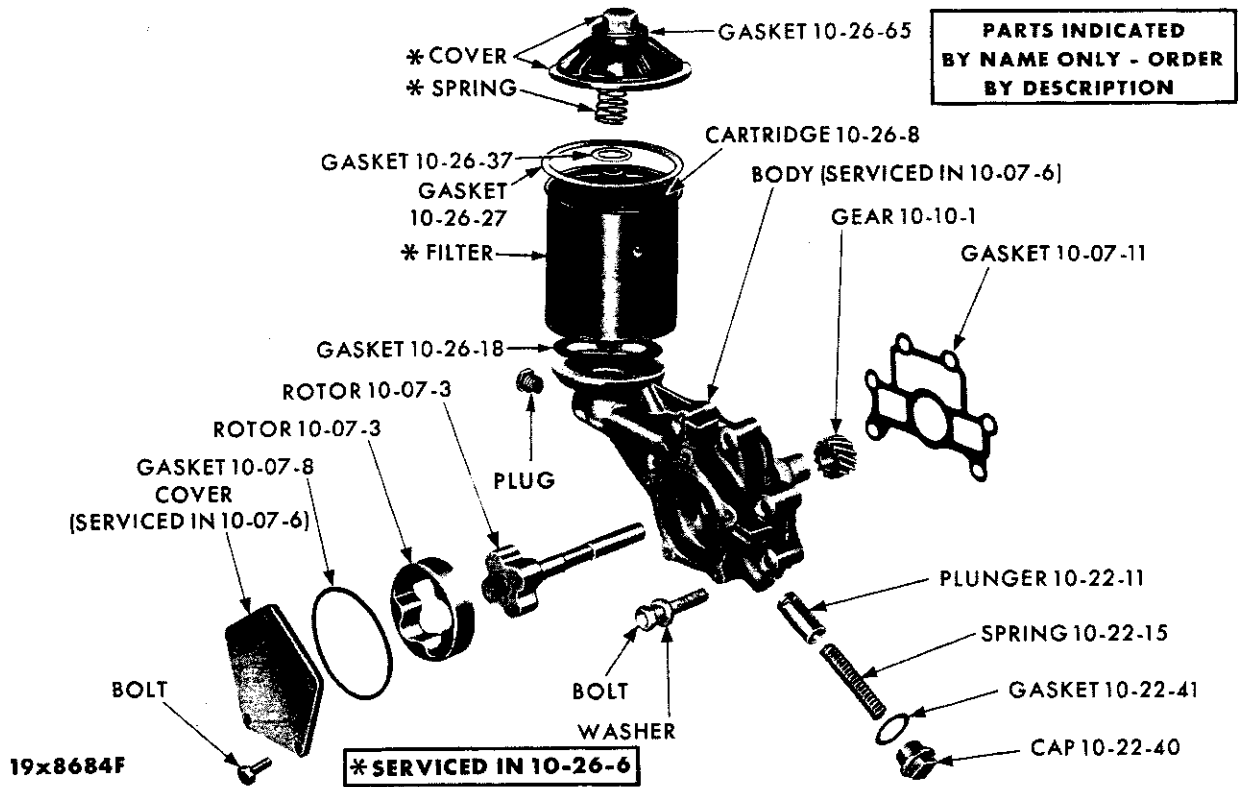

OIL PUMP AND FILTER - 6 CYLINDER

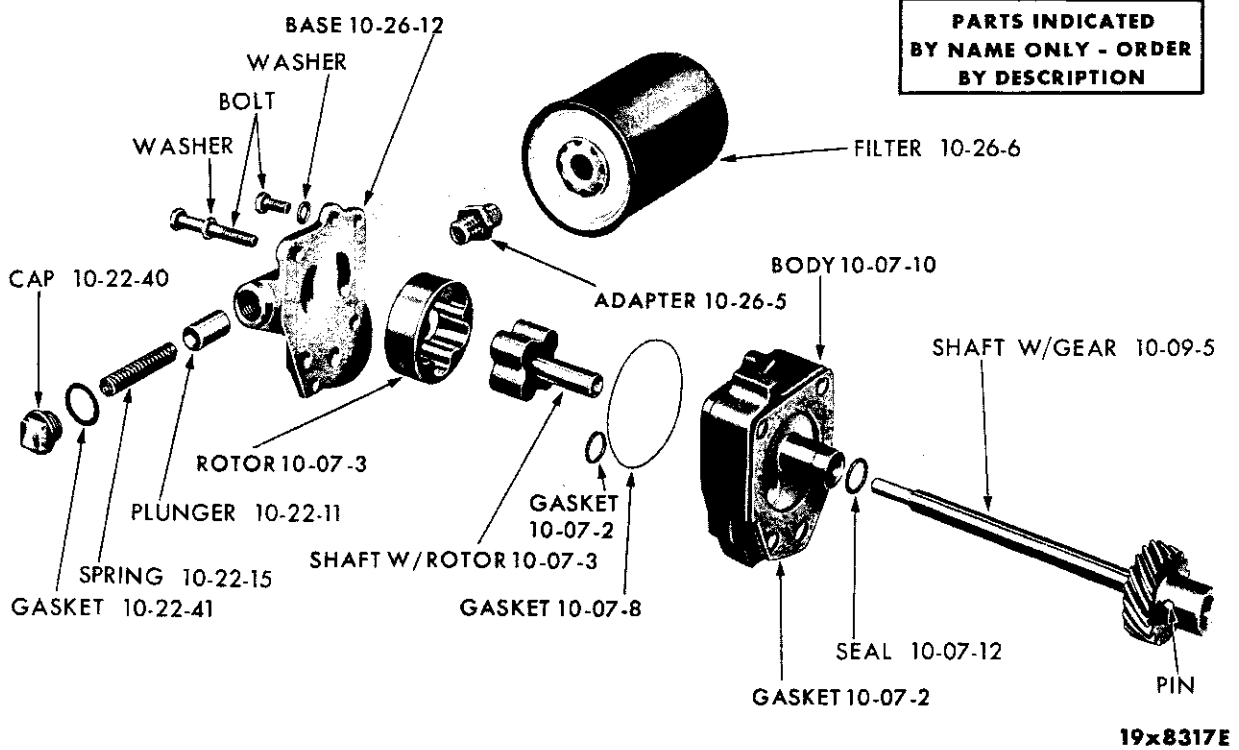

OIL PUMP - 361 CU. IN. ENGINE

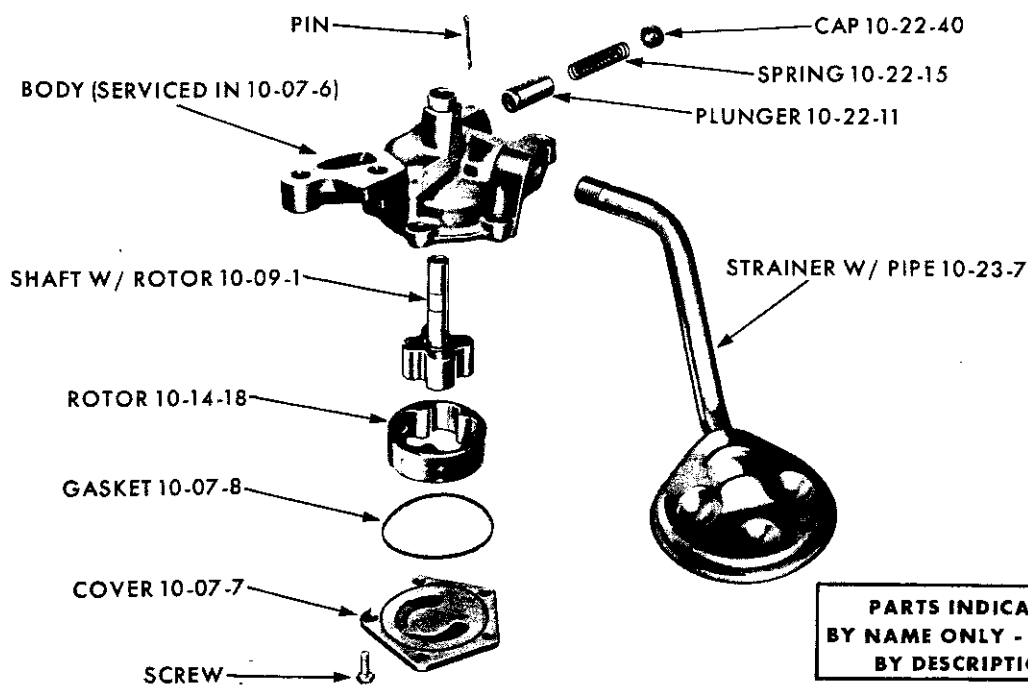

19x9226

OIL PUMP - V8 CYLINDER

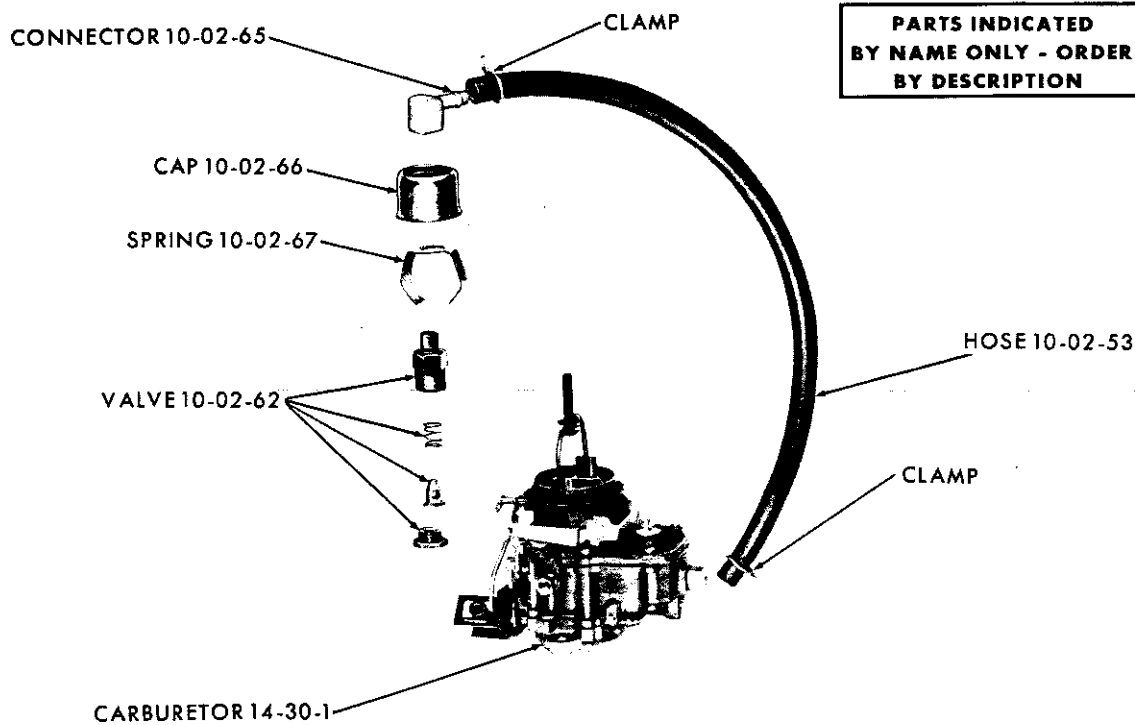

19x9077A

CRANKCASE - CLOSED VENT SYSTEM

CODE	PART NAME AND DESCRIPTION	CYL	PER CAR	VALIANT DART	PLYMOUTH DODGE	CHRYSLER IMPERIAL
10-01-O CRANKCASE VENT INLET AIR CLEANER						
10-01-21	AIR CLEANER, Crankcase Vent Inlet, Std.		1	2402 199	2402 199	2402 199
	Heavy Duty		1	2402 013	2402 013	2402 013
10-02-O CRANKCASE CLOSED VENT SYSTEM						
10-02-40	NIPPLE, Intake Manifold Equalizer Tube, TC2-300J	8	1	-----	-----	2206 151
10-02-53	HOSE, Crankcase Vent Valve to Carburetor (sold by the inch)		*	1064 541	1064 541	1064 541
10-02-62	VALVE, Vent, Crankcase use w/170 cu. in. Eng.	6	1	2448 743		
	Use w/225 cu. in. Eng.		1	2448 742	2448 742	2448 742
10-02-65	CONNECTOR, Crankcase Vent Valve		1	2203 118	2203 118	2203 118
10-02-66	CAP, Crankcase Vent Valve		1	2203 116	2203 116	2203 116
10-02-67	SPRING, Crankcase Vent Valve Cap		1	2203 117	2203 117	2203 117
10-03-O OIL LEVEL INDICATOR						
10-03-4	INDICATOR, w/170 cu.in.Eng., 20 3/8" approx. lgh.	6	1	*2121 569		
	w/170 cu.in.Eng., 15 1/8" approx. lgh.	6	1	*2402 836		
	w/170 cu.in.Eng., 18 1/8" approx. lgh.	6	1	E2463 443		
	w/225 cu.in.Eng., 20 15/16" approx. lgh.	6	1	*2206 319		
	w/225 cu.in.Eng., 15 11/16" approx. lgh.	6	1	*2402 837		
	w/225 cu.in.Eng., 18 11/16" approx. lgh.	6	1	*2463 444		
	TP1, TD1, 21 1/8" approx. lgh.	6	1	-----	*2264 092	
	TP1, TD1, 15 7/8" approx. lgh.	6	1	-----	*2402 838	
	TP1, TD1, 18 7/8" approx. lgh.	6	1	-----	E2463 445	
	w/318 cu.in. Eng.	8	1	-----	2402 839	
	w/361 and 383 cu.in. Eng., except TA3	8	1	-----	2402 840	
	w/426 cu.in.Eng., 24 25/32" approx. lgh.	8	1	-----	*2463 186	
	w/426 cu.in.Eng., 26 25/32" approx. lgh.	8	1	-----	*2465 257	
	TA3	8	1	-----	2402 841	2402 841
10-03-7	TUBE, 9 3/32" lgh.	6	1	1859 788	1859 788	
	3 7/8" lgh.	6	1	2406 366	2406 366	
	w/318 cu. in. Eng.	8	1	-----	1859 788	
	w/318 cu. in. Eng., use w/Leece Neville Alternator, w/o Air Conditioning	8	1	-----	2463 010	
	w/361 and 383 cu. in. Eng.	8	1	-----	1944 652	
	w/426 cu.in. Eng.	8	1	-----	2402 311	
		8	1	-----	-----	1944 652
10-07-O OIL PUMP						
10-07-2	GASKET and SEAL PACKAGE	8	1	-----	2084 355	2084 355
10-07-3	SHAFT and ROTOR PACKAGE	6	1	2084 415	2084 415	
	w/361, 383 and 426 cu.in. Eng.	8	1	-----	2084 354	
		8	1	-----	-----	2084 354
10-07-6	PUMP, UP TO Eng., T17-3-11 and T22-3-11	6	1	*1947 221	*1947 221	
	AFTER Eng., T17-3-11 and T22-3-11	6	1	*2463 382	*2463 382	
	w/318 cu.in.Eng.	8	1	-----	*2402 474	
	w/361 and 383 cu.in. Eng.	8	1	-----	2120 870	
	w/426 cu.in.Eng.	8	1	-----	*2465 092	
		8	1	-----	-----	2120 870
10-07-7	COVER, w/318 cu. in. Eng.	8	1	-----	2206 095	
10-07-8	GASKET, Cover		1	2268 921	2268 921	2268 921

★ Indicates use as required.

Numerals in parentheses () refer to notes.

Printed in U.S.A.

□ Indicates parts not listed in any previous parts book.

Prices and specifications subject to change without notice.

* Indicates change or addition.

CODE	PART NAME AND DESCRIPTION	CYL.	PER CAR	VALIANT DART	PLYMOUTH DODGE	CHRYSLER IMPERIAL
10-07-0 OIL PUMP - Cont'd						
10-07-10	BODY, w/361 and 383 cu.in. Eng.	8	1	----	1737 718	
	w/426 cu.in. Eng.	8	1	----	2406 662	
		8	1	----	----	1737 718
10-07-11	GASKET, Body	6	1	2121 404	2121 404	
10-07-12	SEAL, Body, w/361, 383 and 426 cu.in. Eng. . . .	8	1	----	1855 328	
10-07-14	SHIELD, Oil Pump Body Splash	6	1	2269 072	2269 072	
10-09-0 OIL PUMP DRIVE SHAFT						
10-09-1	SHAFT, w/Inner Rotor, w/318 cu. in. Eng.	8	1	----	2121 530	
10-09-5	SHAFT, Oil Pump and Distributor Drive w/Gear, w/318 cu. in. Eng.	8	1	----	2121 535	
	w/361 and 383 cu. in. Eng.	8	1	----	1739 604	
	w/426 cu.in. Eng.	8	1	----	2402 639	
		8	1	----	----	1739 604
10-09-7	BUSHING	8	1	----	*1737 725	*1737 725
10-10-0 OIL PUMP DRIVE GEAR						
10-10-1	GEAR	6	1	1947 225	1947 225	
10-14-0 OIL PUMP ROTOR						
10-14-18	ROTOR, Outer w/318 cu. in. Eng.	8	1	----	2121 531	
10-18-0 OIL PUMP SUCTION PIPE						
10-18-4	PIPE, w/426 cu.in. Eng.	8	1	----	2406 679	
10-22-0 OIL PRESSURE RELIEF VALVE						
10-22-11	PLUNGER, UP TO Eng., T17-3-11 and T22-3-11 .	6	1	*2120 764	*2120 764	
	AFTER Eng., T17-3-11 and T22-3-11	6	1	*2406 580	*2406 580	
	TP2, TD2, w/318 cu.in. Eng.	8	1	----	*2120 764	
	TP2, TD2, TA3, w/361, 383 and 426 cu.in. Eng..	8	1	----	*2463 541	*2463 541
10-22-15	SPRING, Std., Red	6	1	1737 742	1737 742	
	Std., Red, w/318 cu. in. Eng.	8	1	----	2264 587	
	Std., Red, w/361 and 383 cu.in. Eng.	8	1	----	1737 742	1737 742
	w/426 cu.in. Eng., Color, Plain	8	1	----	*2406 677	
10-22-16	DAMPER, Spring, w/361, 383 and 426 cu.in. Eng.	8	1	----	2202 845	
		8	1	----	----	2202 845
10-22-40	CAP, Plunger	6	1	618 621	618 621	
	w/318 cu. in. Eng.	8	1	----	2264 586	
	w/361, 383 and 426 cu.in. Eng.	8	1	----	618 621	618 621
10-22-41	GASKET, Cap		1	618 622	618 622	618 622
10-23-0 OIL STRAINER						
10-23-7	STRAINER, w/PIPE, w/170 cu. in. Eng.	6	1	2121 702		
	w/PIPE, w/225 cu. in. Eng.	6	1	2206 317		
	w/PIPE	6	1	----	2206 261	
	w/PIPE, w/318 cu. in. Eng.	8	1	----	2206 381	
	w/PIPE, w/361 and 383 cu. in. Eng., except TA3	8	1	----	2206 458	
	w/o Pipe, w/426 cu.in. Eng.	8	1	----	2406 678	
	w/PIPE, TA3	8	1	----	1859 947	1859 947

★ Indicates use as required.

Numerals in parentheses () refer to notes.

Printed in U.S.A.

☐ Indicates parts not listed in any previous parts book.

Prices and specifications subject to change without notice.

Jan. 3, 1964 Supersedes Dec. 14, 1962.

Page 10-8

* Indicates change or addition.

CODE	PART NAME AND DESCRIPTION	CYL	PER CAR	VALIANT DART	PLYMOUTH DODGE	CHRYSLER IMPERIAL
10-24-O OIL PAN						
10-24-1	GASKET SET	6	1	2240 647	2240 647	
	w/318 cu. in. Eng.	8	1	----	1879 520	
10-24-4	PAN, w/Drain PLUG, w/170 cu. in. Eng.	6	1	2268 446		
	w/Drain PLUG, w/225 cu.in.Eng.	6	1	*2406 688		
	w/o Drain Plug	6	1	----	2206 463	
	w/Drain PLUG, w/318 cu. in. Eng.	8	1	----	2206 373	
	w/o Drain Plug, w/361 and 383 cu. in. Eng., except TA3	8	1	----	2206 455	
	w/o Drain Plug, w/426 cu.in. Eng.	8	1	----	2402 307	
	w/Drain PLUG, TA3	8	1	----	2268 459	2268 459
10-24-8	GASKET, w/361, 383 and 426 cu.in.Eng.	8	1	----	1737 770	1737 770
10-24-23	SCREW, w/WASHER, Pan Attaching, 5/16"-18 x 13/16"	8	2	*1947 953	*1947 953	*1947 953
	5/16"-18 x 1"	6	2	1343 212	1343 212	
	To Bearing Seal Retainer	8	2	----	2121 573	2121 573
10-24-37	PLUG, Drain, 1/2" -20 x 3/4"		1	2268 564	2268 564	2268 564
10-24-38	GASKET, Drain Plug, 1/2" I.D. -7/8" O.D.		1	2268 513	2268 513	2268 513
10-26-O OIL FILTER						
10-26-5	ADAPTER, Base to Filter	8	1	----	*1739 619	*1739 619
	Filter to Cylinder Block, w/318 cu. in. Eng. . .	8	1	----	2206 372	
	PLATE, Filter to Adapter, w/318 cu. in. Eng. . .	8	1	----	2402 103	
10-26-6	FILTER, Replaceable Cartridge Type, Including CARTRIDGE, Heavy Duty	6	1	*2128 548	*2128 548	
	Sealed Can Type, w/Built In Gasket		1	1851 658	1851 658	1851 658
10-26-8	CARTRIDGE		1	*2129 023	*2129 023	
10-26-12	BASE, w/361 and 383 cu.in. Eng.	8	1	----	2120 866	
	w/426 cu. in. Eng.	8	1	----	2406 684	
		8	1	----	----	2120 866
10-26-14	SHELL, Oil Filter, w/318 cu. in. Eng.	8	1	----	2448 371	
10-26-18	GASKET, Oil Filter Body	6	1	2268 870	2268 870	
10-26-27	GASKET, Cover	6	1	2129 024	2129 024	
	Adapter Plate	8	1	----	1557 575	
10-26-37	GASKET, Spring Retainer		1	*1557 584	*1557 584	
10-26-46	STANDPIPE, w/VALVE	6	1	2402 607	2402 607	
10-26-52	GASKET, Oil Filter Standpipe Valve Adapter . . .	6	1	2120 017	2120 017	
10-26-65	GASKET, Oil Filter Tube Cap	6	1	2202 435	2202 435	
	w/318 cu. in. Eng.	8	1	----	1557 581	

NOTES

★ Indicates use as required. Numerals in parentheses () refer to notes. Printed in U.S.A.
 ☐ Indicates parts not listed in any previous parts book. Price and specifications subject to change without notice.
 * Indicates change or addition. Jan. 3, 1964 Supersedes Dec. 14, 1962.

