

1963 PLYMOUTH

INTERIOR TRIM

HOW TO USE INTERIOR TRIM ILLUSTRATIONS

The illustrations in this section are actual and each body style showing the Interior Trim is included.

The letters shown on the illustration indicate the description of the part and the part type code when referred to the legend which appears preceding the listing of the parts. The letters are consistent throughout the illustrations as "A" is always a Door Trim Panel, Code 23-92-5.

The numbers on the illustration indicate the distribution of material and type of material used. The numbers may vary with each illustration. The legend appears on the illustration.

For complete information on "How to Order" Trim Parts, see Mopar Parts Price List.

P
L
Y
M
O
U
T
H

1963 PLYMOUTH - T SERIES

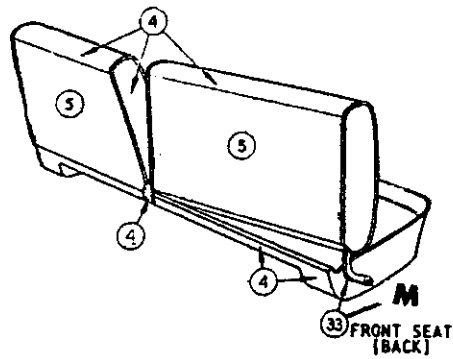
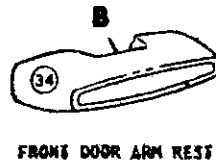
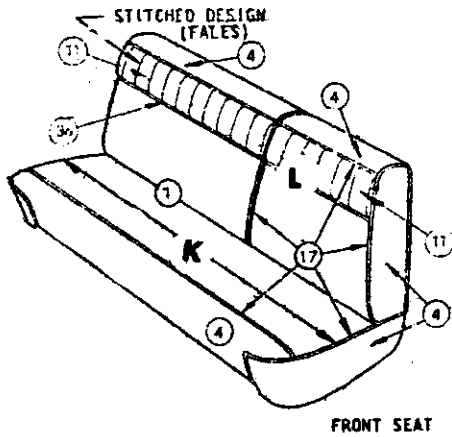
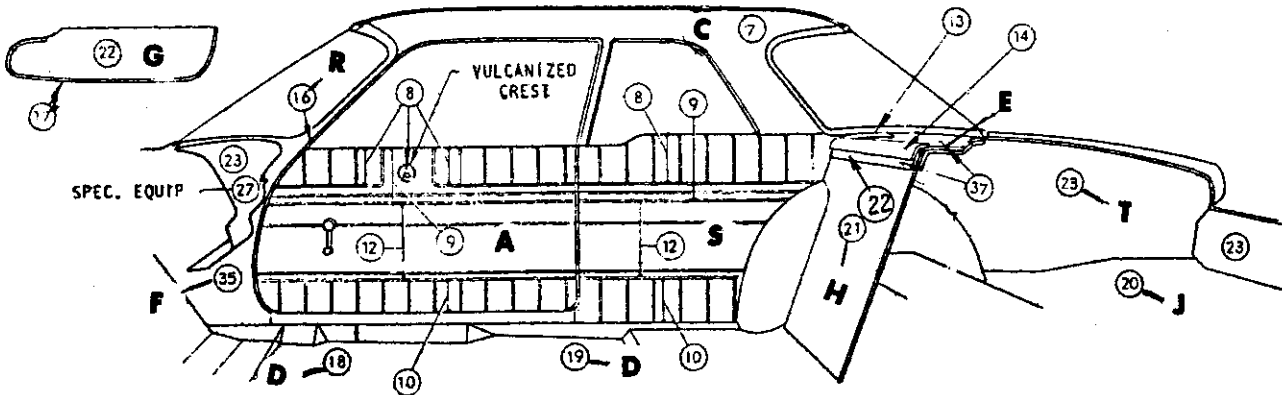

DISTRIBUTION OF MATERIAL

1	BODY CLOTH	1
4	IMITATION LEATHER	28-AM-22
5	IMITATION LEATHER	21-DK-72
7	IMITATION LEATHER	17-C-81 OPT 15.5-C-81
8	IMITATION LEATHER	19-DJ-22
9	IMITATION LEATHER	18-DN-22
10	IMITATION LEATHER	.012 -L-22
11	IMITATION LEATHER	28A-AM-22
12	IMITATION LEATHER	.012A-L-22
13	IMITATION LEATHER	19A-C-22
14	IMITATION LEATHER	28B-AM-22
16	LACE	
17	EXTRUDED VINYL	
18	FLOOR COVERING-FRONT RUBBER	
19	FLOOR COVERING-REAR RUBBER	
20	FLOOR COVERING-LUGG. COMPT. RUBBER	
21	CARDBOARD	
23	PAINT	
24	METAL	
25	MOULDING	
26	MYLAR	
27	MOULDED RESIN	
28	MOULDED RUBBER	
29	MOULDED VINYL	
30	WOVEN PAPER	
32	CARPET	
33	PLASTIC	
34	PLASTISOL	
35	POLYETHLENE	
36	EXTRUDED VINYL MYLAR FILLER	
37	HARDBOARD	

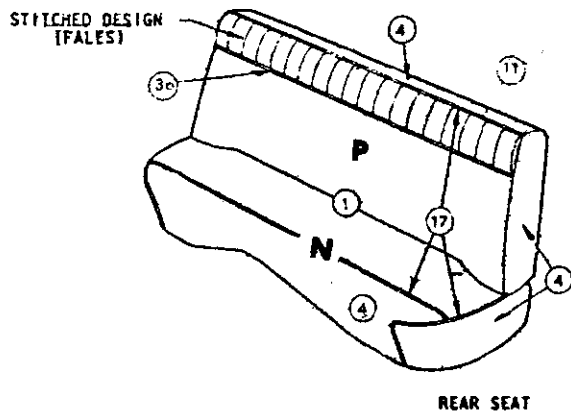

Distribution Drawing Legend Page Appears Following Illustration Section

Codes 301, 303, 306

TPL-211

1963 PLYMOUTH TP1-L, TP2-L 2 DOOR SEDAN
CLOTH AND IMITATION LEATHER COMBINATION

1963 PLYMOUTH - T SERIES

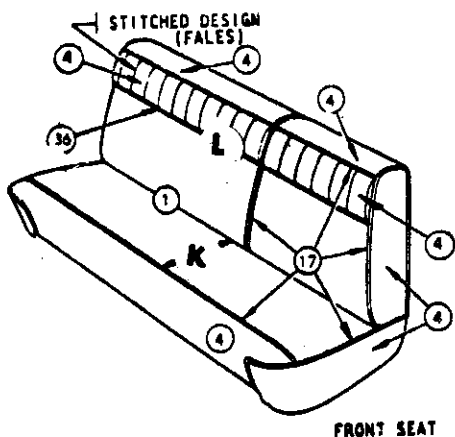
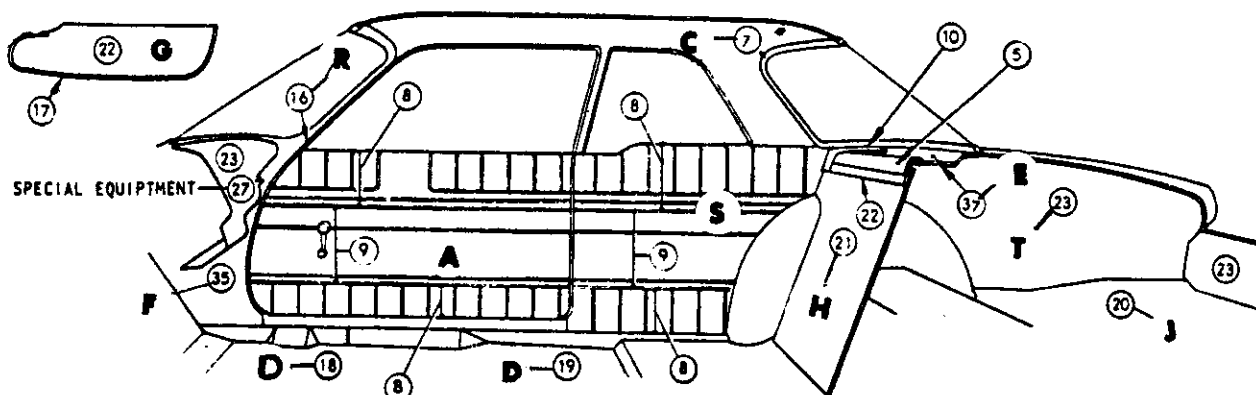

FRONT SEAT



FRONT DOOR ARM REST

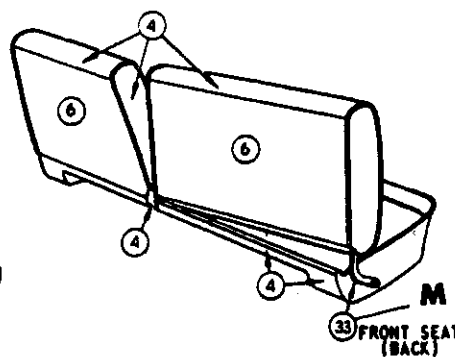

FRONT SEAT (BACK)

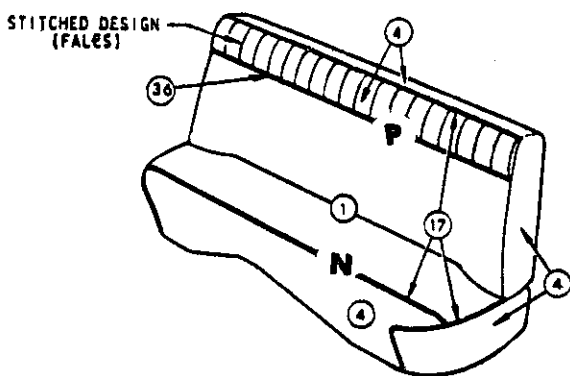

REAR SEAT

DISTRIBUTION OF MATERIAL

1	BODY CLOTH	1
4	IMITATION LEATHER	28-AM-22
5	IMITATION LEATHER	28A-AM-22
6	IMITATION LEATHER	19-C-22
7	IMITATION LEATHER	17-C-81 OPT 15, 5-C-81
8	IMITATION LEATHER	19-DJ-22
9	IMITATION LEATHER	21-CM-22
10	IMITATION LEATHER	19A-C-22
16	LACE	
17	EXTRUDED VINYL	
18	FLOOR COVERING-FRONT RUBBER	
19	FLOOR COVERING-REAR RUBBER	
20	FLOOR COVERING-LUGG. COMPT. RUBBER	
21	CARDBOARD	
22	EMBOSSED CARDBOARD	
23	PAINT	
24	METAL	
25	MOULDING	
26	MYLAR	
27	MOULDED RESIN	
28	MOULDED RUBBER	
29	MOULDED VINYL	
32	CARPET	
33	PLASTIC	
34	PLASTISOL	
35	POLYETHYLENE	
36	EXTRUDED VINYL MYLAR FILLER	
37	HARDBOARD	

Distribution Drawing Legend Page Appears Following Illustration Section

Code 394

TPL-211A

1963 PLYMOUTH TP1-L, TP2-L 2 DOOR SEDAN
CLOTH AND IMITATION LEATHER COMBINATION

1963 PLYMOUTH - T SERIES

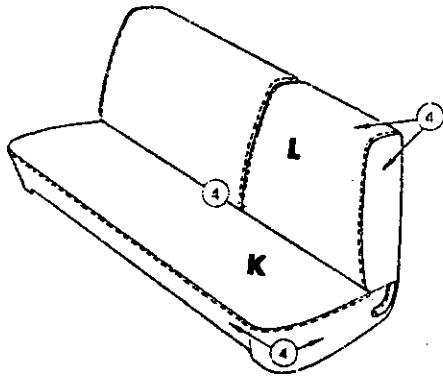
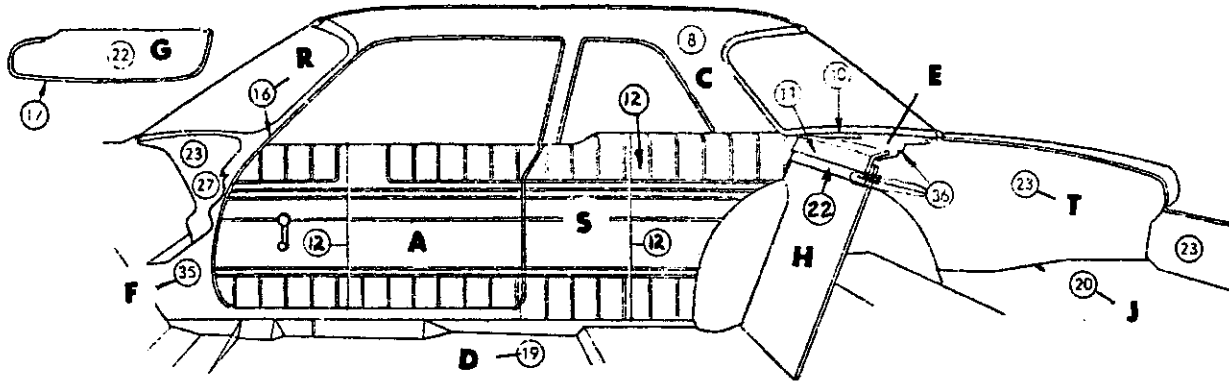

FRONT SEAT

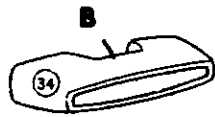

FRONT DOOR ARM RESTS

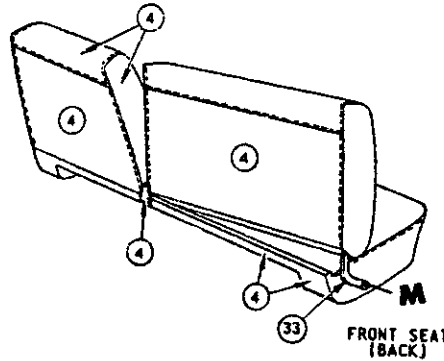

FRONT SEAT (BACK)

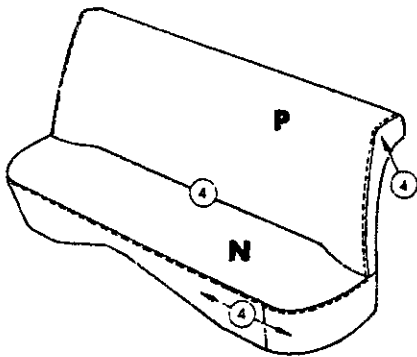

REAR SEAT

DISTRIBUTION OF MATERIAL

4	IMITATION LEATHER	37-CX-22
8	IMITATION LEATHER	17-C-81 OPT 15, 5-C-81
9	IMITATION LEATHER	19-DJ-22
10	IMITATION LEATHER	19A-C-22
11	IMITATION LEATHER	28-AM-22
16	LACE	
17	EXTRUDED VINYL	
18	FLOOR COVERING-FRONT	RUBBER
19	FLOOR COVERING-REAR	RUBBER
20	FLOOR COVERING-LUGG. COMPT.	RUBBER
21	CARDBOARD	
22	EMBOSSED CARDBOARD	
23	PAINT	
24	METAL	
25	MOULDING	
26	MYLAR	
27	MOULDED RESIN	
28	MOULDED RUBBER	
29	MOULDED VINYL	
32	CARPET	
33	PLASTIC	
34	PLASTISOL	
35	POLYETHYLENE	
36	HARDBOARD	

Distribution Drawing Legend Page Appears Following Illustration Section

Code 494

TPL-214A

1963 PLYMOUTH TP1-L, TP2-L 2 DOOR SEDAN
IMITATION LEATHER

1963 PLYMOUTH - T SERIES

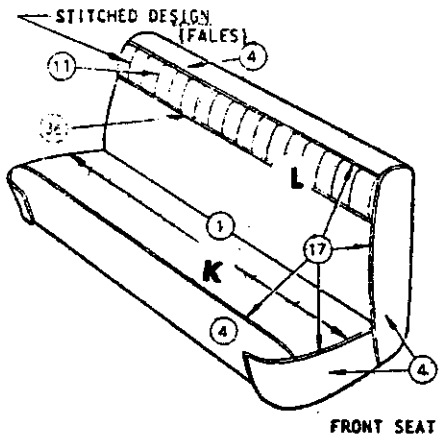
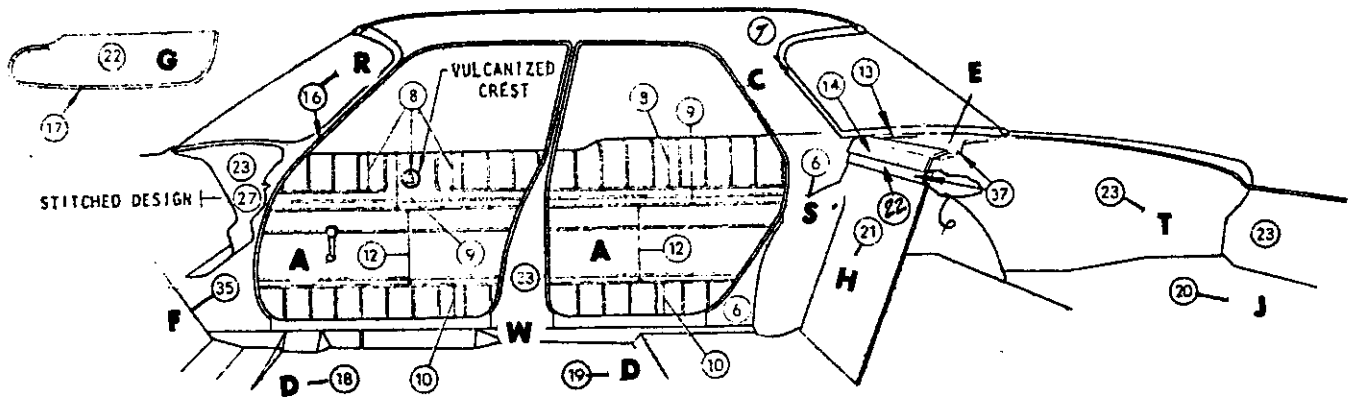

FRONT SEAT

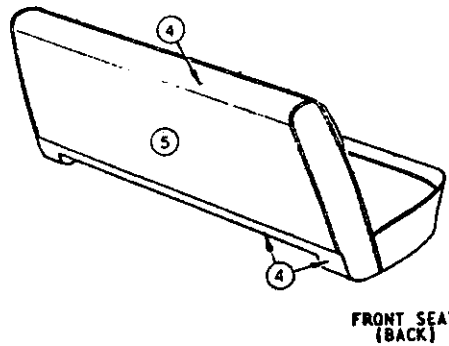

FRONT SEAT (BACK)

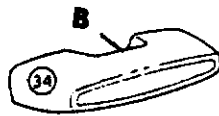

FRONT DOOR ARM REST

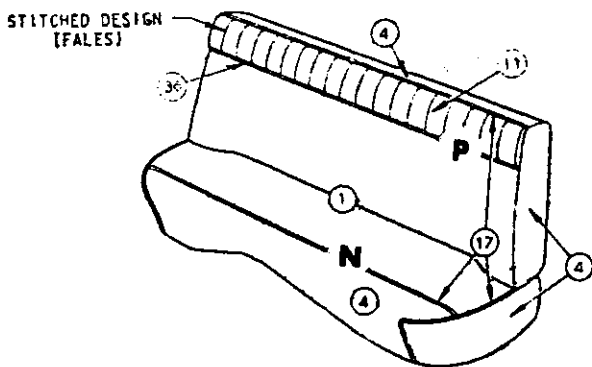

REAR SEAT

DISTRIBUTION OF MATERIAL

1	BODY CLOTH	1
4	IMITATION LEATHER	28-AM-22
5	IMITATION LEATHER	21-DK-72
6	IMITATION LEATHER	19-C-22
7	IMITATION LEATHER	17-C-81 OPT 15, 5-C-81
8	IMITATION LEATHER	19-DJ-22
9	IMITATION LEATHER	18-DN-22
10	IMITATION LEATHER	.012-L-22
11	IMITATION LEATHER	28A-AM-22
12	IMITATION LEATHER	.012A-L-22
13	IMITATION LEATHER	19A-C-22
14	IMITATION LEATHER	28B-AM-22
16	LACE	
17	EXTRUDED VINYL	
18	FLOOR COVERING-FRONT RUBBER	
19	FLOOR COVERING-REAR RUBBER	
20	FLOOR COVERING-LUGG. COMPT, RUBBER	
21	CARDBOARD	
22	EMBOSSED CARDBOARD	
23	PAINT	
24	METAL	
25	MOULDING	
26	MYLAR	
27	MOULDED RESIN	
28	MOULDED RUBBER	
29	MOULDED VINYL	
32	CARPET	
33	PLASTIC	
34	PLASTISOL	
35	POLYETHLENE	
36	EXTRUDED VINYL MYLAR FILLER	
37	HARDBOARD	

Distribution Drawing Legend Page Appears Following Illustration Section

Codes 301, 303, 306

TPL-411

1963 PLYMOUTH TP1-L, TP2-L 4 DOOR SEDAN
CLOTH AND IMITATION LEATHER COMBINATION

1963 PLYMOUTH - T SERIES

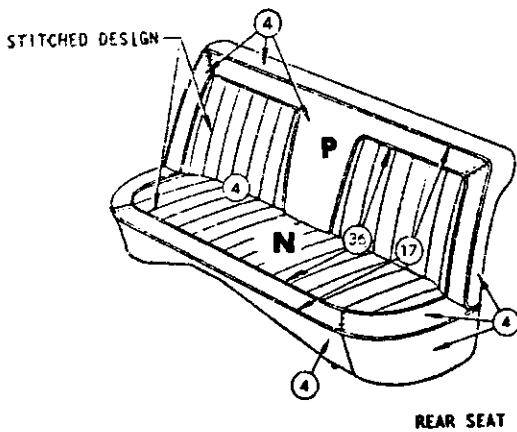
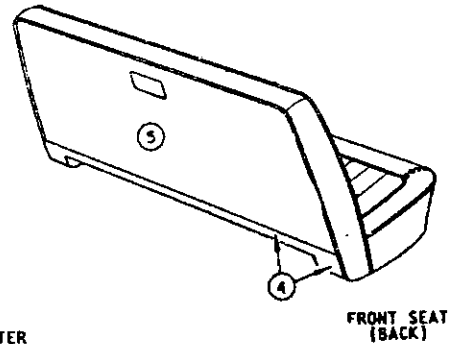
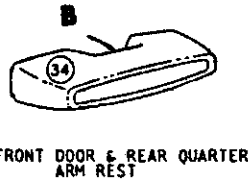
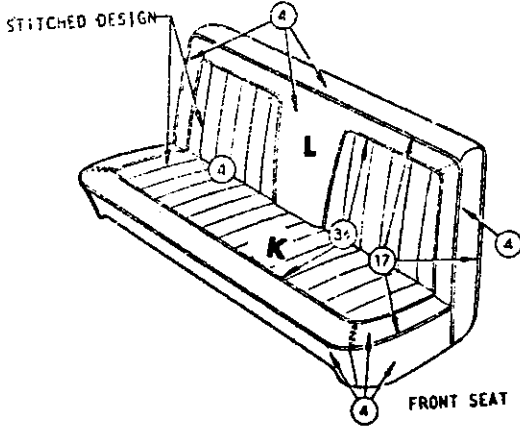
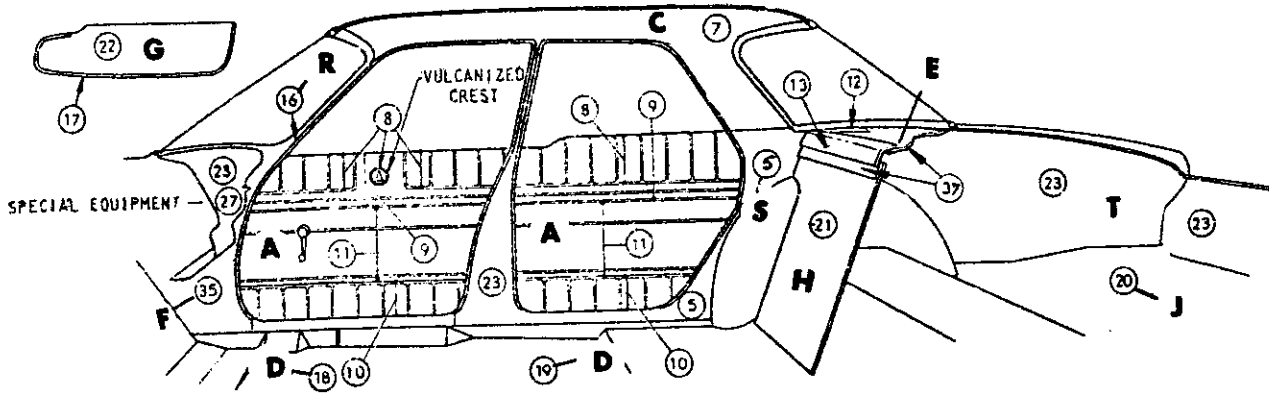

DISTRIBUTION OF MATERIAL

4	IMITATION LEATHER	28-AM-22
5	IMITATION LEATHER	19-C-22
7	IMITATION LEATHER	17-C-81 OPT 15.5-C-81
8	IMITATION LEATHER	19-DJ-22
9	IMITATION LEATHER	18-DN-22
10	IMITATION LEATHER	.012-L-22
11	IMITATION LEATHER	.012A-L-22
12	IMITATION LEATHER	19A-C-22
13	IMITATION LEATHER	28A-AM-22
16	LACE	
17	EXTRUDED VINYL	
18	FLOOR COVERING-FRONT RUBBER	
19	FLOOR COVERING-REAR RUBBER	
20	FLOOR COVERING-LUGG. COMPT. RUBBER	
21	CARDBOARD	
22	EMBOSSED CARDBOARD	
23	PAINT	
24	METAL	
25	MOULDING	
26	MYLAR	
27	MOULDED RESIN	
28	MOULDED RUBBER	
29	MOULDED VINYL	
32	CARPET	
33	PLASTIC	
34	PLASTISOL	
35	POLYETHLENE	
36	EXTRUDED VINYL MYLAR FILLER	
37	HARDBOARD	

Distribution Drawing Legend Page Appears Following Illustration Section

Codes 411, 413

TPL-414

1963 PLYMOUTH TP1-L, TP2-L 4 DOOR SEDAN
IMITATION LEATHER COMBINATION

1963 PLYMOUTH - T SERIES

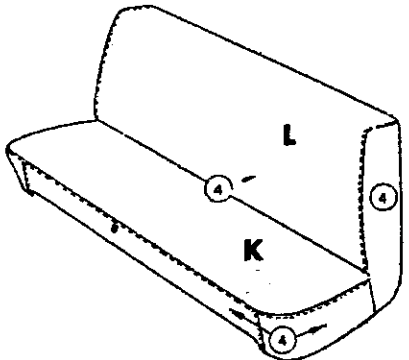
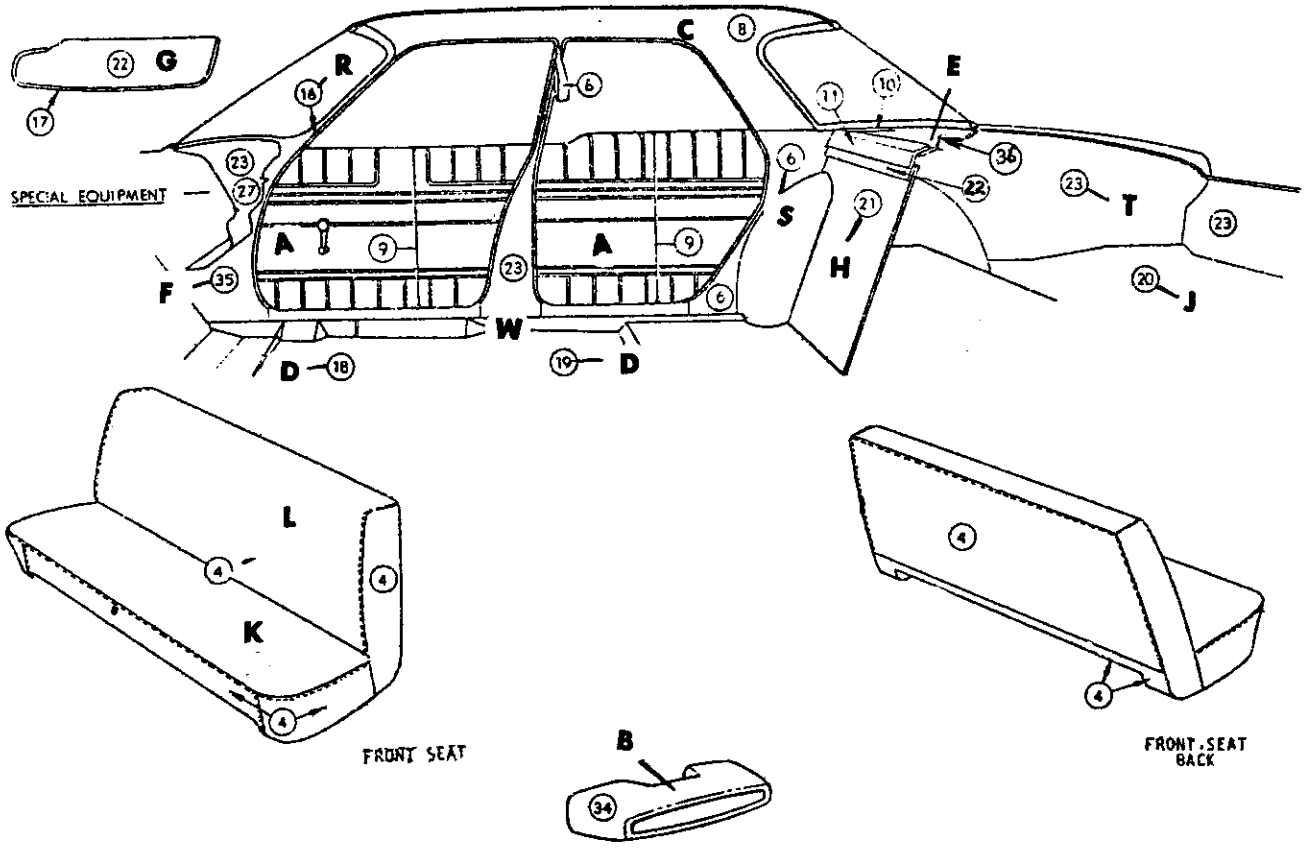

FRONT SEAT

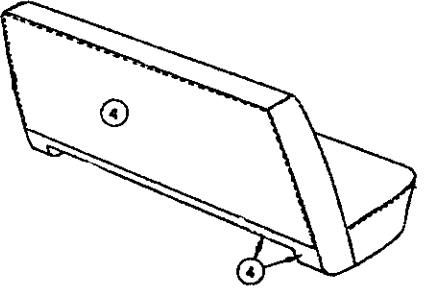

FRONT SEAT BACK

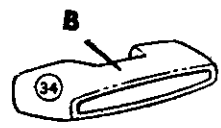

FRONT & REAR DOOR ARM RESTS

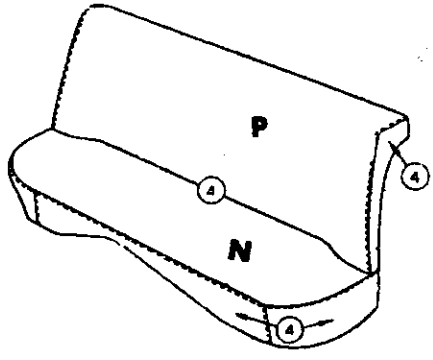

REAR SEAT

DISTRIBUTION OF MATERIAL

4	IMITATION LEATHER	37-CX-22
6	IMITATION LEATHER	19-C-22
8	IMITATION LEATHER	17-C-81 OPT 15.5-C-81
9	IMITATION LEATHER	19-DJ-22
10	IMITATION LEATHER	19A-C-22
11	IMITATION LEATHER	28-AM-22
16	LACE	
17	EXTRUDED VINYL	
18	FLOOR COVERING-FRONT	RUBBER
19	FLOOR COVERING-REAR	RUBBER
20	FLOOR COVERING-LUGG. COMPT.	RUBBER
21	CARDBOARD	
22	EMBOSSED CARDBOARD	
23	PAINT	
24	METAL	
25	MOULDING	
26	MYLAR	
27	MOULDED RESIN	
28	MOULDED RUBBER	
29	MOULDED VINYL	
32	CARPET	
33	PLASTIC	
34	PLASTISOL	
35	POLYETHYLENE	
36	HARDBOARD	

Distribution Drawing Legend Page Appears Following Illustration Section

Code 494

TPL-414A

1963 PLYMOUTH TP1-L, TP2-L 4 DOOR SEDAN
IMITATION LEATHER

1963 PLYMOUTH - T SERIES

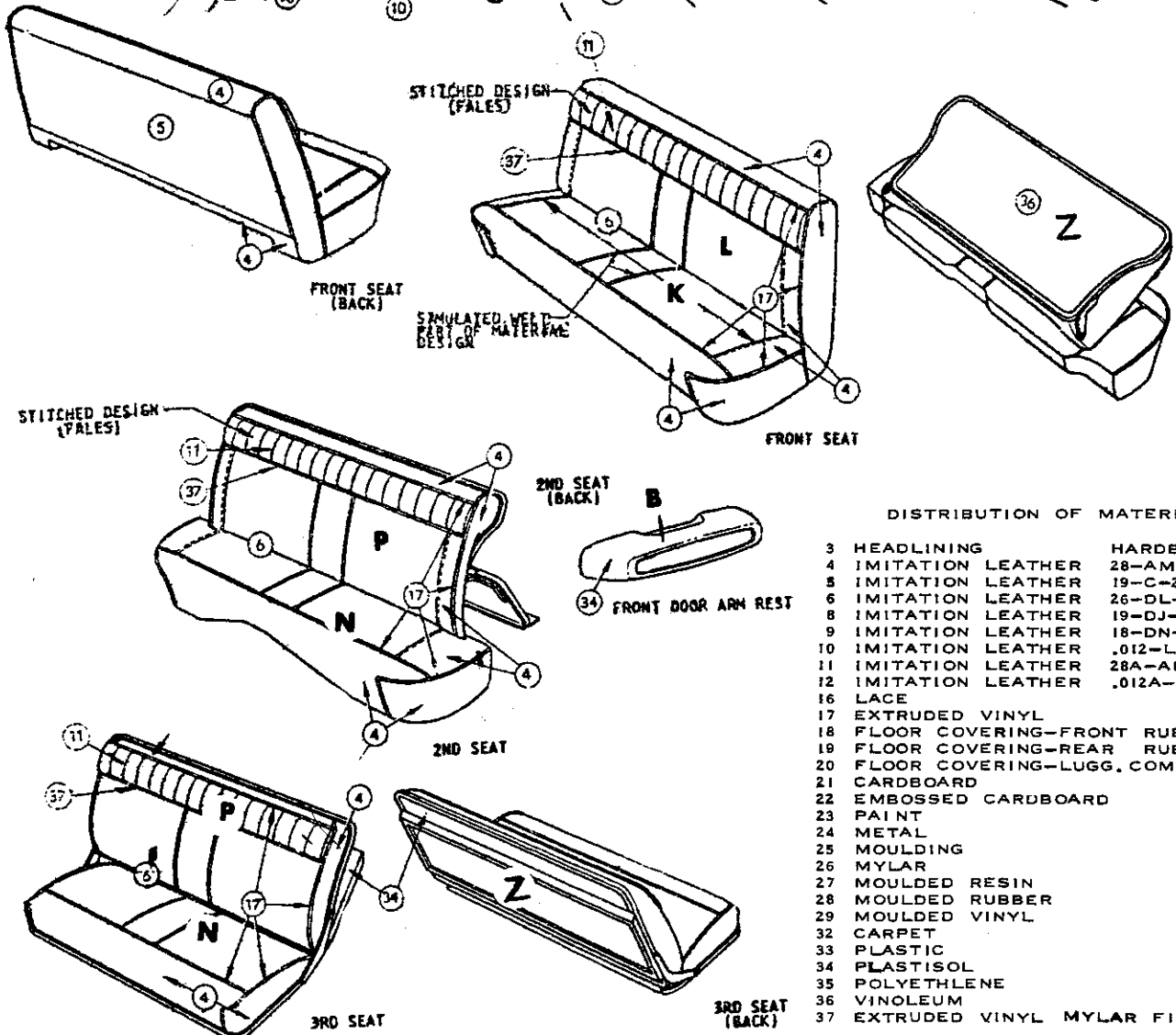
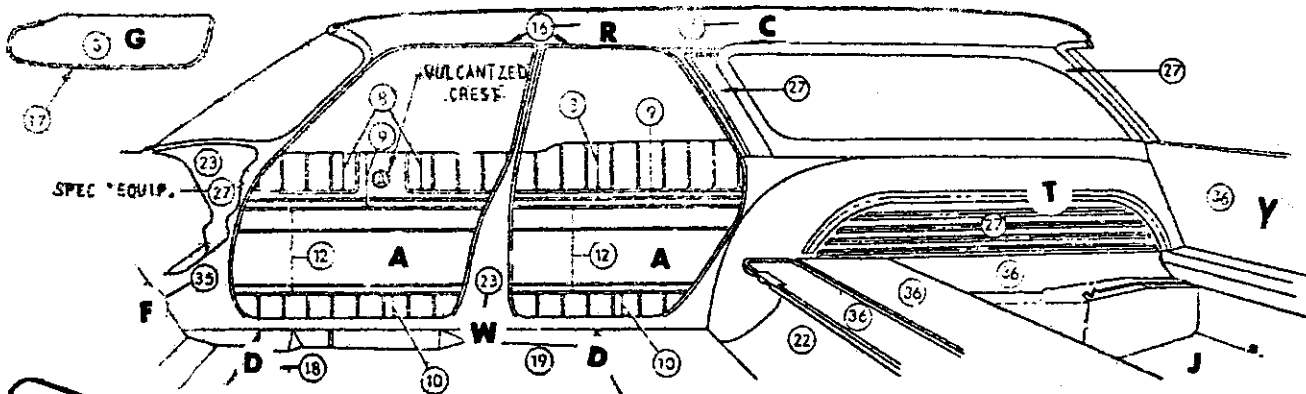

DISTRIBUTION OF MATERIAL

3	HEADLINING	HARDBOARD
4	IMITATION LEATHER	28-AM-22
5	IMITATION LEATHER	19-C-22
6	IMITATION LEATHER	26-DL-73
8	IMITATION LEATHER	19-DJ-22
9	IMITATION LEATHER	18-DN-22
10	IMITATION LEATHER	.012-L-22
11	IMITATION LEATHER	28A-AM-22
12	IMITATION LEATHER	.012A-L-22
16	LACE	
17	EXTRUDED VINYL	
18	FLOOR COVERING-FRONT RUBBER	
19	FLOOR COVERING-REAR RUBBER	
20	FLOOR COVERING-LUGG.COMPT.	
21	CARDBOARD	
22	EMBOSSED CARDBOARD	
23	PAINT	
24	METAL	
25	MOULDING	
26	MYLAR	
27	MOULDED RESIN	
28	MOULDED RUBBER	
29	MOULDED VINYL	
32	CARPET	
33	PLASTIC	
34	PLASTISOL	
35	POLYETHYLENE	
36	VINOLEUM	
37	EXTRUDED VINYL MYLAR FILLER	

Distribution Drawing Legend Page Appears Following Illustration Section

Codes 401, 403, 406

TPL-454

1963 PLYMOUTH TP1-L, TP2-L 4 DOOR SUBURBAN
IMITATION LEATHER

1963 PLYMOUTH - T SERIES

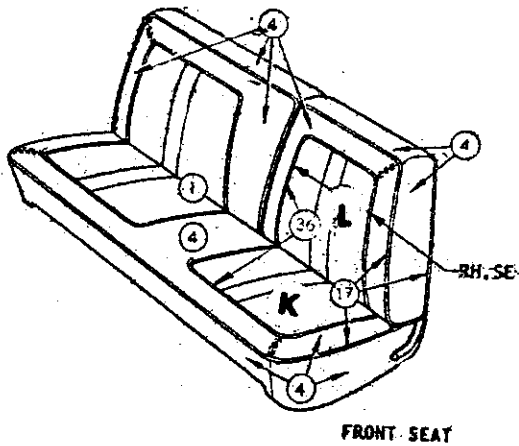
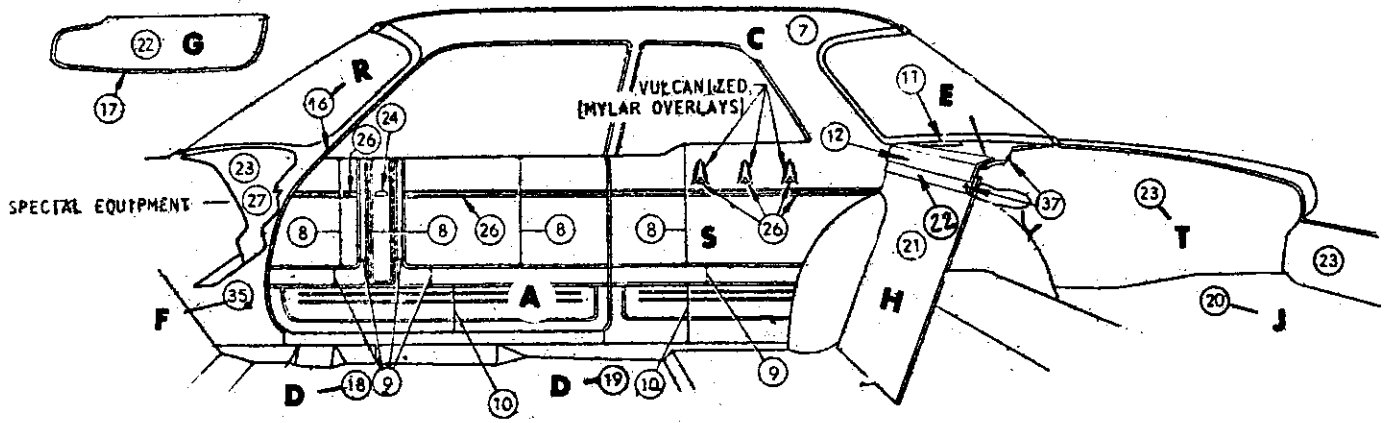

FRONT SEAT

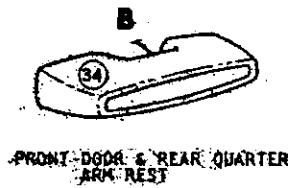

FRONT DOOR & REAR QUARTER ARM REST

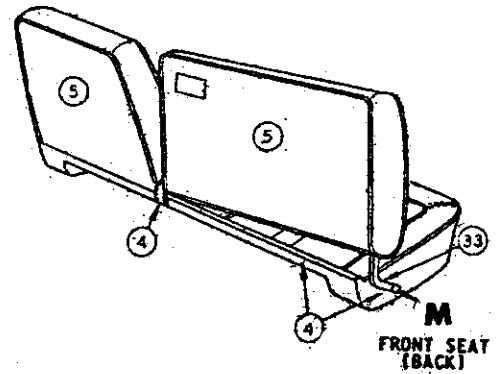

FRONT SEAT (BACK)

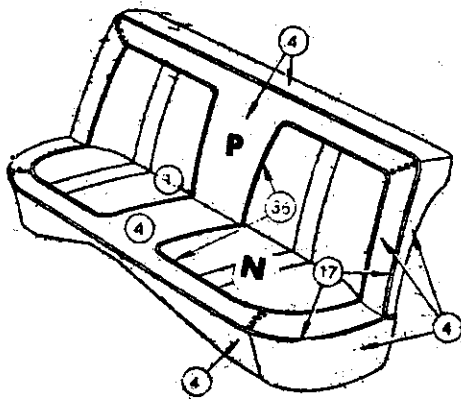

REAR SEAT

DISTRIBUTION OF MATERIAL

1	BODY CLOTH	1
4	IMITATION LEATHER	28-AM-22
5	IMITATION LEATHER	21-DK-72
7	IMITATION LEATHER	17-C-81 OPT 15, 5-C-81
8	IMITATION LEATHER	19-DJ-22
9	IMITATION LEATHER	18-DN-22
10	IMITATION LEATHER	.012-L-22
11	IMITATION LEATHER	19A-C-22
12	IMITATION LEATHER	28A-AM-22
16	LACE	
17	EXTRUDED VINYL	
18	FLOOR COVERING-FRONT CARPET	
19	FLOOR COVERING-REAR CARPET	
20	FLOOR COVERING-LUGG. COMPT, RUBBER	
21	CARDBOARD	
23	PAINT	
24	METAL	
25	MOULDING	
26	MYLAR	
27	MOULDED RESIN	
28	MOULDED RUBBER	
29	MOULDED VINYL	
32	CARPET	
33	PLASTIC	
34	PLASTISOL	
35	POLYETHLENE	
36	EXTRUDED VINYL MYLAR FILLER	
37	HARDBOARD	

Distribution Drawing Legend Page Appears Following Illustration Section

Plain Design

Codes 321, 322, 323, 325, 326

TPM-211

1963 PLYMOUTH TP1-M, TP2-M 2 DOOR SEDAN
CLOTH AND IMITATION LEATHER COMBINATION

1963 PLYMOUTH - T SERIES

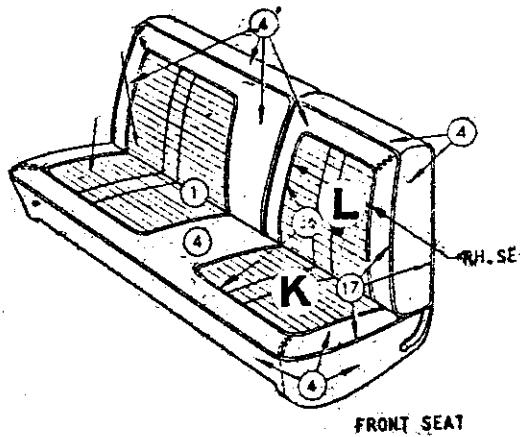
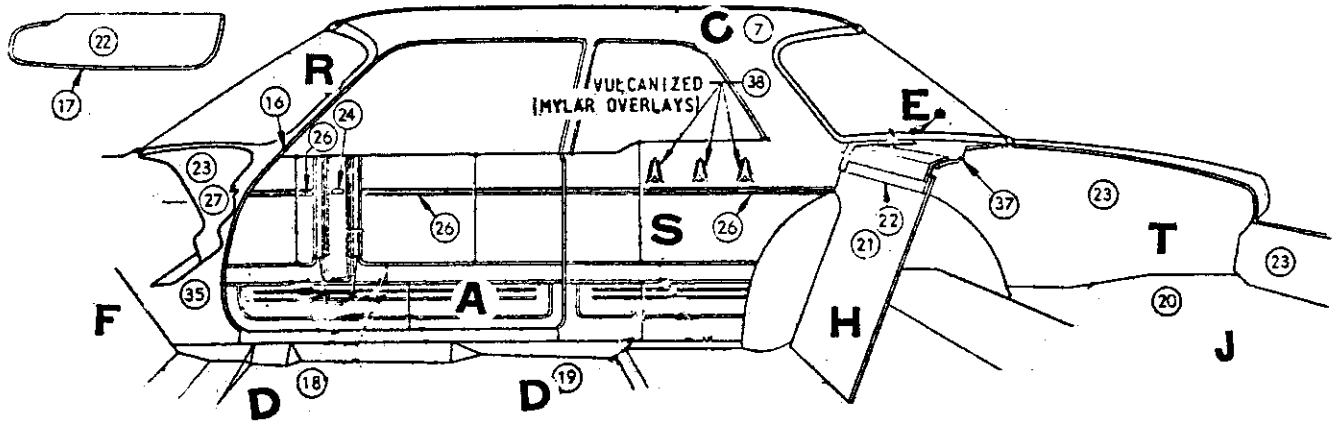

FRONT SEAT

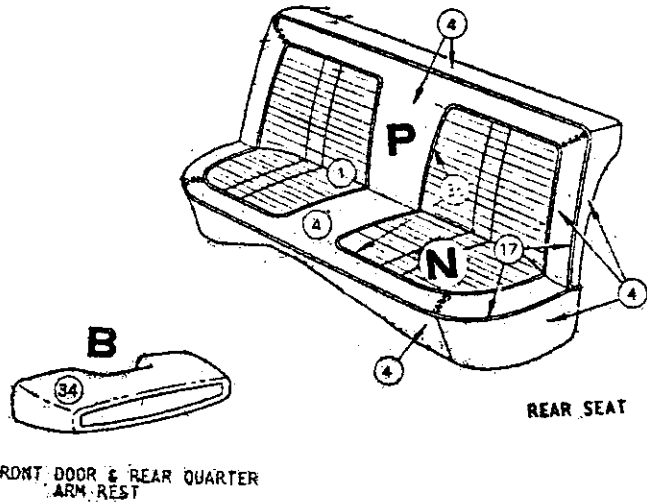

FRONT DOOR & REAR QUARTER ARM REST

REAR SEAT

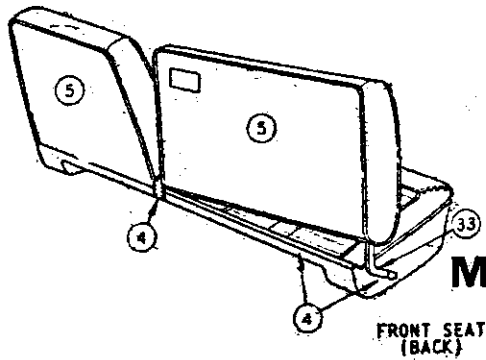

FRONT SEAT (BACK)

DISTRIBUTION OF MATERIAL

- 1 BODY CLOTH I
- 4 IMITATION LEATHER 28-AM-22
- 5 IMITATION LEATHER 21-DK-72
- 16 LACE
- 17 EXTRUDED VINYL
- 18 FLOOR COVERING-FRONT CARPET
- 19 FLOOR COVERING-REAR CARPET
- 20 FLOOR COVERING-LUGG. COMPT. RUBBER
- 21 CARDBOARD
- 22 EMBOSSED CARDBOARD
- 23 PAINT
- 24 METAL
- 25 MOULDING
- 26 MYLAR NO. 1
- 27 MOULDED RESIN
- 28 MOULDED RUBBER
- 29 MOULDED VINYL
- 32 CARPET
- 33 PLASTIC
- 34 PLASTISOL
- 35 POLYETHYLENE
- 36 EXTRUDED VINYL MYLAR FILLER
- 37 HARDBOARD
- 38 MYLAR NO. 2

Distribution Drawing Legend Page Appears Following Illustration Section

Stitched Design

Codes 321, 322, 323, 325, 326

TPM-211

1963 PLYMOUTH TP1-M, TP2-M 2 DOOR SEDAN
CLOTH & IMITATION LEATHER COMBINATION

1963 PLYMOUTH - T SERIES

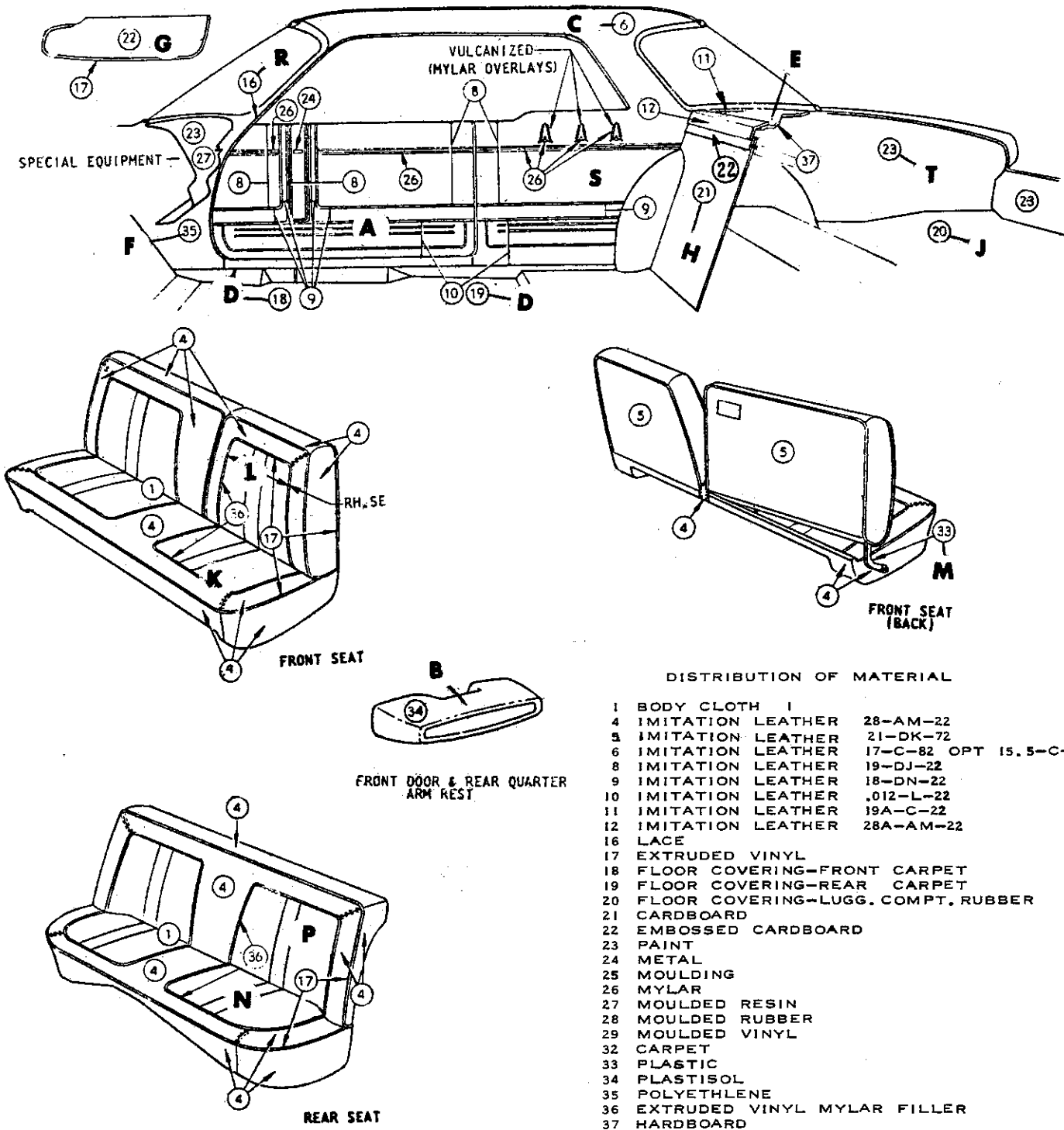

Distribution Drawing Legend Page Appears Following Illustration Section Plain Design

Codes 321, 323, 325, 326

TPM-231 1963 PLYMOUTH TP1-M, TP2-M SPECIAL CLUB COUPE CLOTH AND IMITATION LEATHER COMBINATION

1963 PLYMOUTH - T SERIES

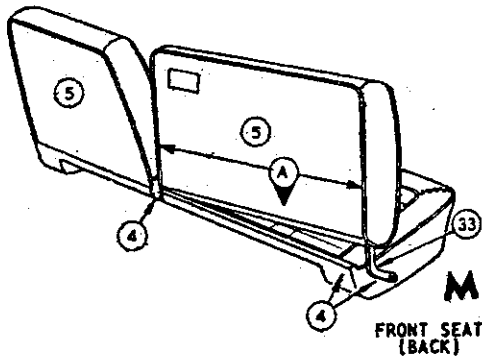
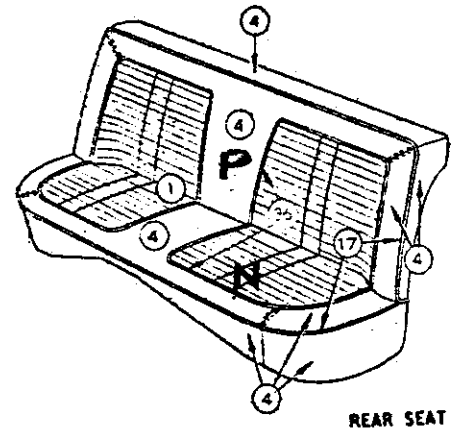
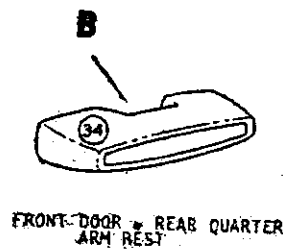
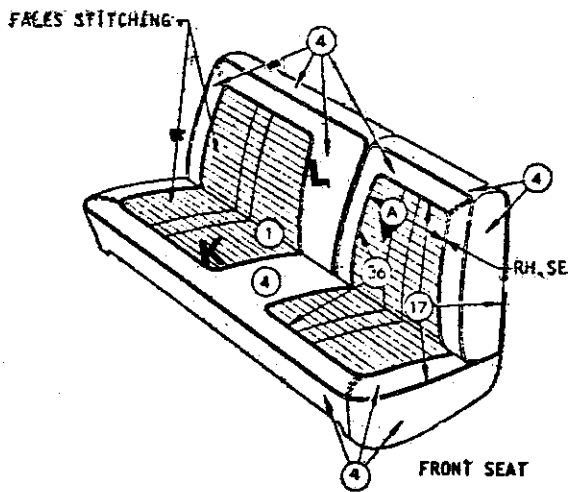
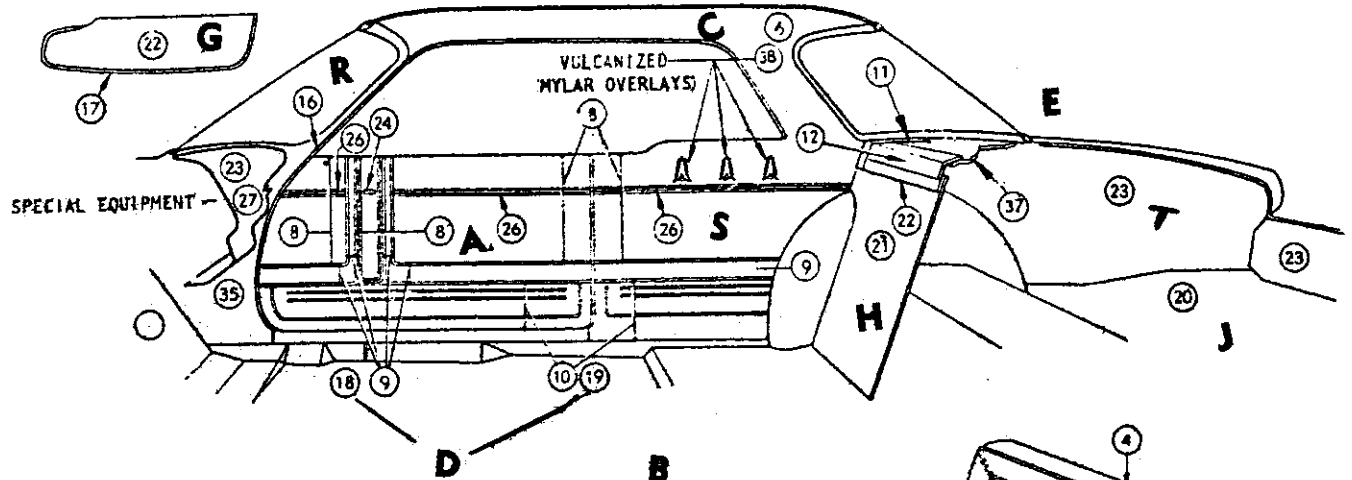

DISTRIBUTION OF MATERIAL

1	BODY CLOTH	1
4	IMITATION LEATHER	28-AM-22
5	IMITATION LEATHER	21-DK-72
6	IMITATION LEATHER	15, 5-C-81
7	IMITATION LEATHER	
8	IMITATION LEATHER	19-DJ-22
9	IMITATION LEATHER	18-DN-22
10	IMITATION LEATHER	. 012-L-22
11	IMITATION LEATHER	19A-C-22
12	IMITATION LEATHER	28A-AM-22
16	LACE	
17	EXTRUDED VINYL	
18	FLOOR COVERING-FRONT CARPET	
19	FLOOR COVERING-REAR CARPET	
20	FLOOR COVERING-LUGG. COMPT. RUBBER	
21	CARDBOARD	
22	EMBOSSED CARDBOARD	
23	PAINT	
24	METAL	
25	MOULDING	
26	MYLAR NO. 1	
27	MOULDED RESIN	
28	MOULDED RUBBER	
29	MOULDED VINYL	
32	CARPET	
33	PLASTIC	
34	PLASTISOL	
35	POLYETHLENE	
36	EXTRUDED VINYL MYLAR FILLER	
37	HARDBOARD	
38	MYLAR NO. 2	

Distribution Drawing Legend Page Appears Following Illustration Section

Stitched Design

Codes 321, 323, 325, 326

TPM-231 1963 PLYMOUTH TP1-M, TP2-M SPECIAL CLUB COUPE
CLOTH & IMITATION LEATHER COMBINATION

1963 PLYMOUTH - T SERIES

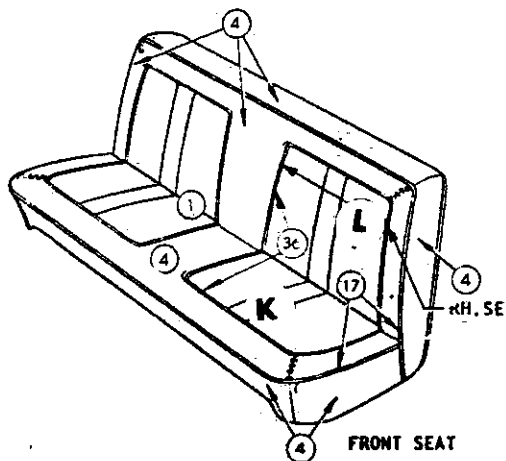
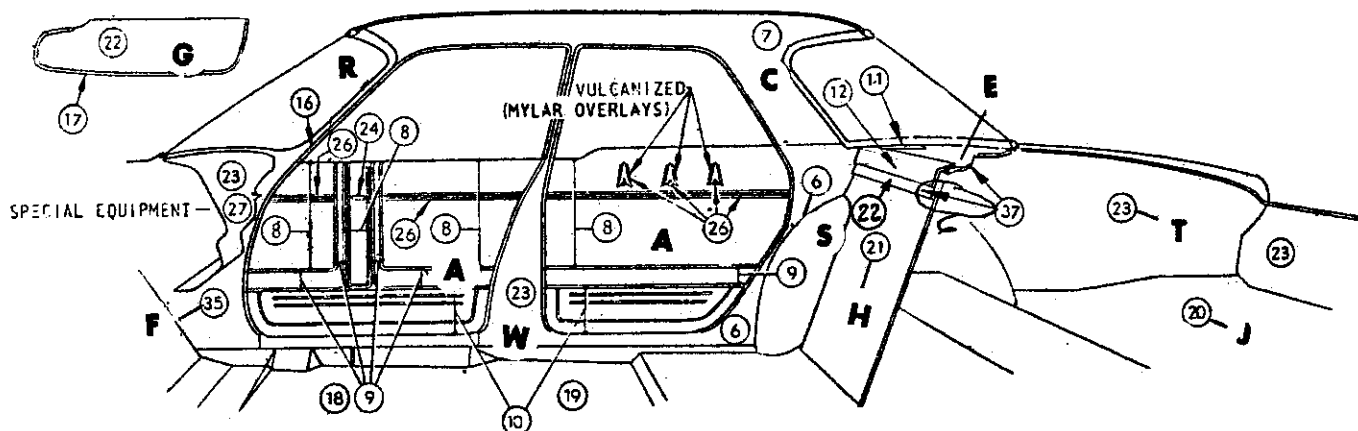

FRONT DOOR & REAR QUARTER ARM REST

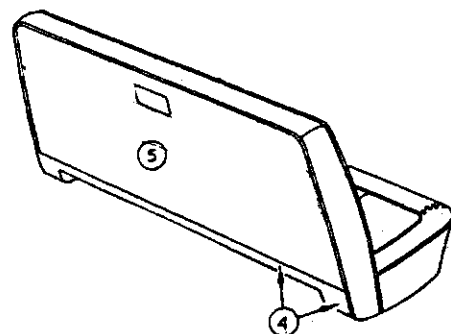

FRONT SEAT (BACK)

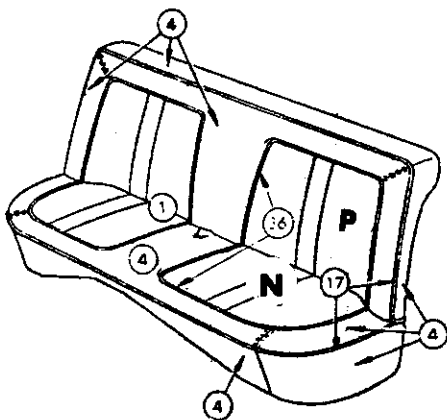

REAR SEAT

DISTRIBUTION OF MATERIAL

1	BODY CLOTH	1
4	IMITATION LEATHER	28-AM-22
5	IMITATION LEATHER	21-DK-72
6	IMITATION LEATHER	19-C-22
7	IMITATION LEATHER	17-C-81 OPT 15, 5-C-81
8	IMITATION LEATHER	19-DJ-22
9	IMITATION LEATHER	18-DN-22
10	IMITATION LEATHER	.012-L-22
11	IMITATION LEATHER	19A-C-22
12	IMITATION LEATHER	28A-AM-22
16	LACE	
17	EXTRUDED VINYL	
18	FLOOR COVERING-FRONT CARPET	
19	FLOOR COVERING-REAR CARPET	
20	FLOOR COVERING-LUGG. COMPT. RUBBER	
21	CARDBOARD	
22	EMBOSSSED CARDBOARD	
23	PAINT	
24	METAL	
25	MOULDING	
26	MYLAR	
27	MOULDED RESIN	
28	MOULDED RUBBER	
29	MOULDED VINYL	
32	CARPET	
33	PLASTIC	
34	PLASTISOL	
35	POLYETHYLENE	
36	EXTRUDED VINYL MYLAR FILLER	
37	HARDBOARD	

Distribution Drawing Legend Page Appears Following Illustration Section

Plain Design

Codes 321, 322, 323, 325, 326

TPM-411

1963 PLYMOUTH TP1-M, TP2-M 4 DOOR SEDAN
CLOTH AND IMITATION LEATHER COMBINATION

1963 PLYMOUTH - T SERIES

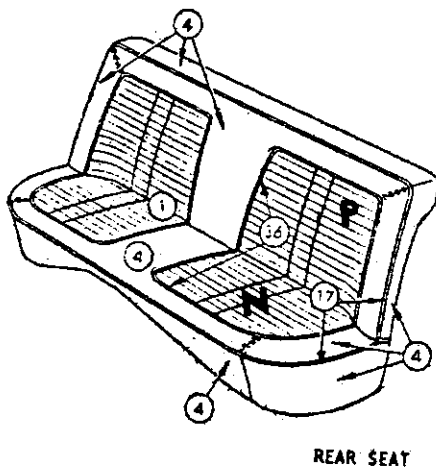
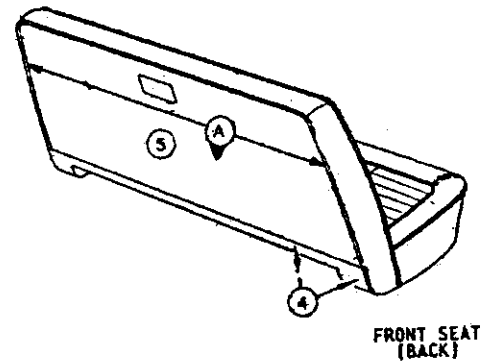
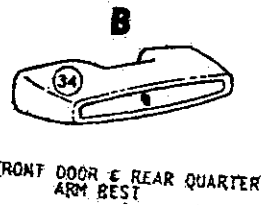
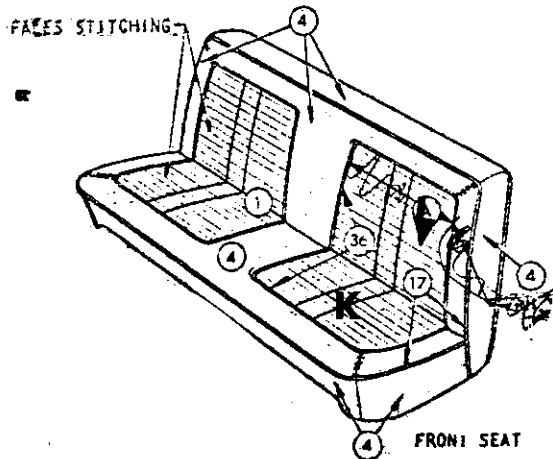
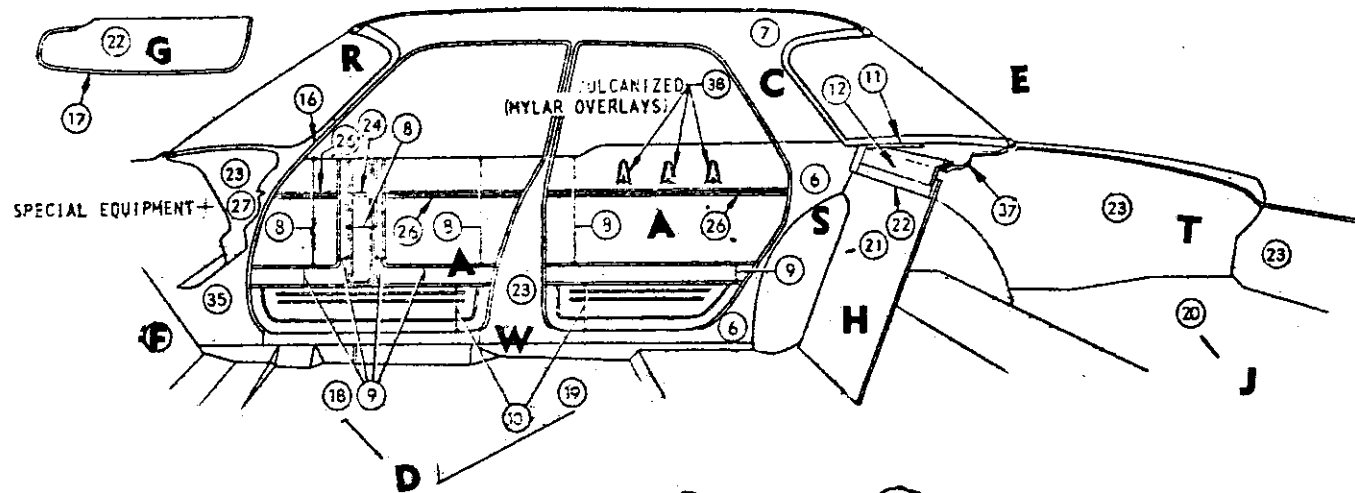

DISTRIBUTION OF MATERIAL

- 1 BODY CLOTH I
- 4 IMITATION LEATHER 28-AM-22
- 5 IMITATION LEATHER 21-DK-72
- 6 IMITATION LEATHER 19-C-22
- 7 IMITATION LEATHER 15.5-C-81
- 8 IMITATION LEATHER 19-DJ-22
- 9 IMITATION LEATHER 18-DN-22
- 10 IMITATION LEATHER .012-L-22
- 11 IMITATION LEATHER 19A-C-22
- 12 IMITATION LEATHER 28A-AM-22
- 16 LACE
- 17 EXTRUDED VINYL
- 18 FLOOR COVERING-FRONT CARPET
- 19 FLOOR COVERING-REAR CARPET
- 20 FLOOR COVERING-LUGG. COMPT. RUBBER
- 21 CARDBOARD
- 22 EMBOSSED CARDBOARD
- 23 PAINT
- 24 METAL
- 25 MOULDING
- 26 MYLAR
- 27 MOULDED RESIN
- 28 MOULDED RUBBER
- 29 MOULDED VINYL
- 32 CARPET
- 33 PLASTIC
- 34 PLASTISOL
- 35 POLYETHYLENE
- 36 EXTRUDED VINYL MYLAR FILLER
- 37 HARDBOARD
- 38 MYLAR NO. 2

Distribution Drawing Legend Page Appears Following Illustration Section
 Stitched Design Codes 321, 322, 323, 325, 326

TPM-411 1963 PLYMOUTH TP1-M, TP2-M 4 DOOR SEDAN
 CLOTH & IMITATION LEATHER COMBINATION

1963 PLYMOUTH - T SERIES

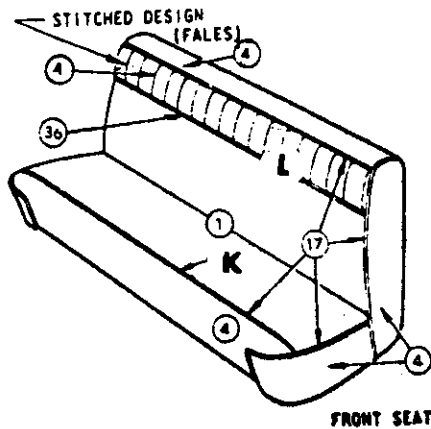
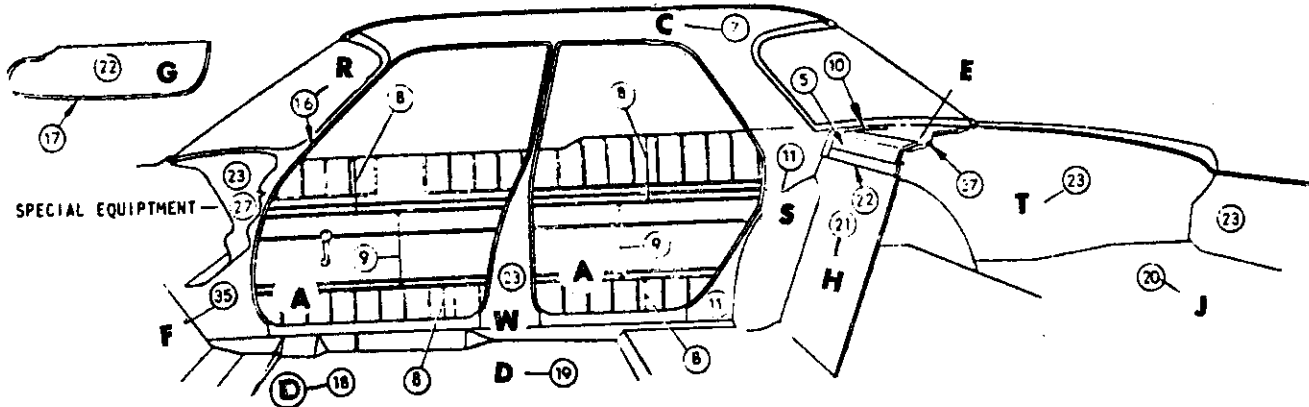

FRONT SEAT

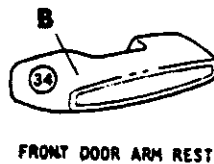

FRONT DOOR ARM REST

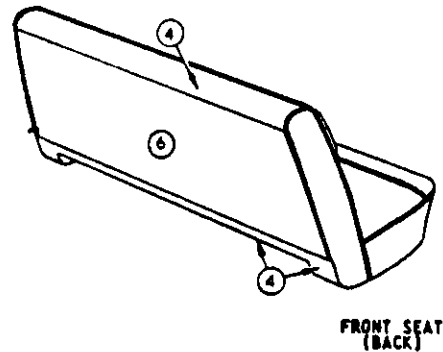

FRONT SEAT (BACK)

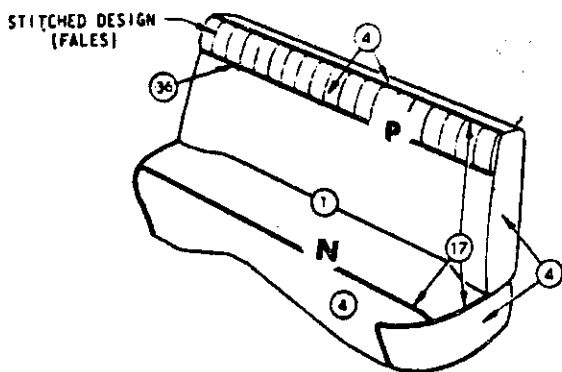

REAR SEAT

DISTRIBUTION OF MATERIAL

- | | | |
|----|------------------------------------|-----------------------|
| 1 | BODY CLOTH | 1 |
| 4 | IMITATION LEATHER | 28-AM-22 |
| 5 | IMITATION LEATHER | 28A-AM-22 |
| 6 | IMITATION LEATHER | 19-C-22 |
| 7 | IMITATION LEATHER | 17-C-81 OPT 15.5-C-81 |
| 8 | IMITATION LEATHER | 19-DJ-22 |
| 9 | IMITATION LEATHER | 21-CM-22 |
| 10 | IMITATION LEATHER | 19A-C-22 |
| 11 | IMITATION LEATHER | 19B-C-22 |
| 16 | LACE | |
| 17 | EXTRUDED VINYL | |
| 18 | FLOOR COVERING-FRONT RUBBER | |
| 19 | FLOOR COVERING-REAR RUBBER | |
| 20 | FLOOR COVERING-LUGG. COMPT. RUBBER | |
| 21 | CARDBOARD | |
| 22 | EMBOSSED CARDBOARD | |
| 23 | PAINT | |
| 24 | METAL | |
| 25 | MOULDING | |
| 26 | MYLAR | |
| 27 | MOULDED RESIN | |
| 28 | MOULDED RUBBER | |
| 29 | MOULDED VINYL | |
| 32 | CARPET | |
| 33 | PLASTIC | |
| 34 | PLASTISOL | |
| 35 | POLYETHLENE | |
| 36 | EXTRUDED VINYL MYLAR FILLER | |
| 37 | HARDBOARD | |

Distribution Drawing Legend Page Appears Following Illustration Section

Code 394

TPL-411A

1963 PLYMOUTH TP1-L, TP2-L 4 DOOR SEDAN
CLOTH AND IMITATION LEATHER COMBINATION

1963 PLYMOUTH - T SERIES

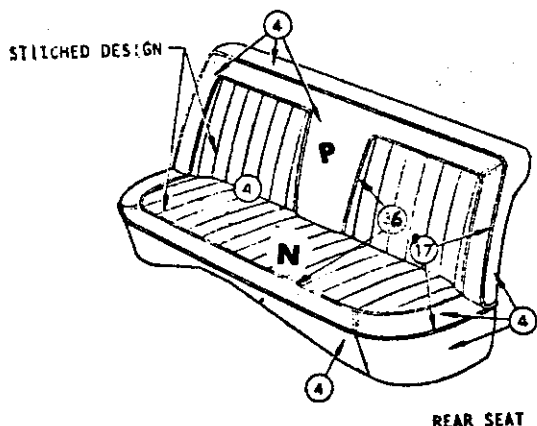
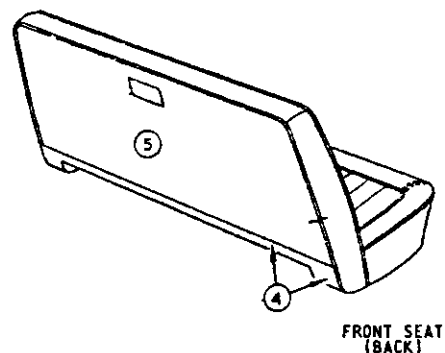
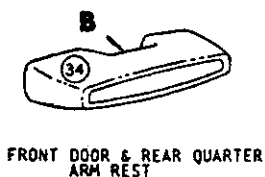
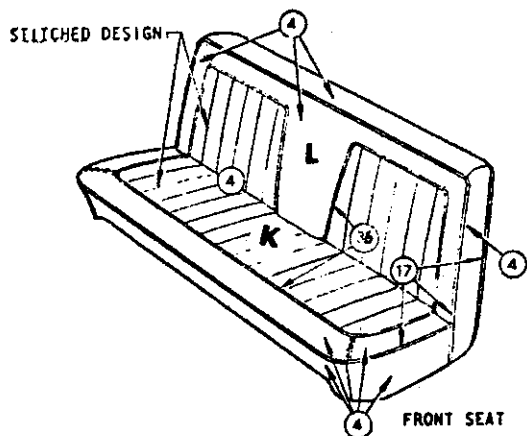
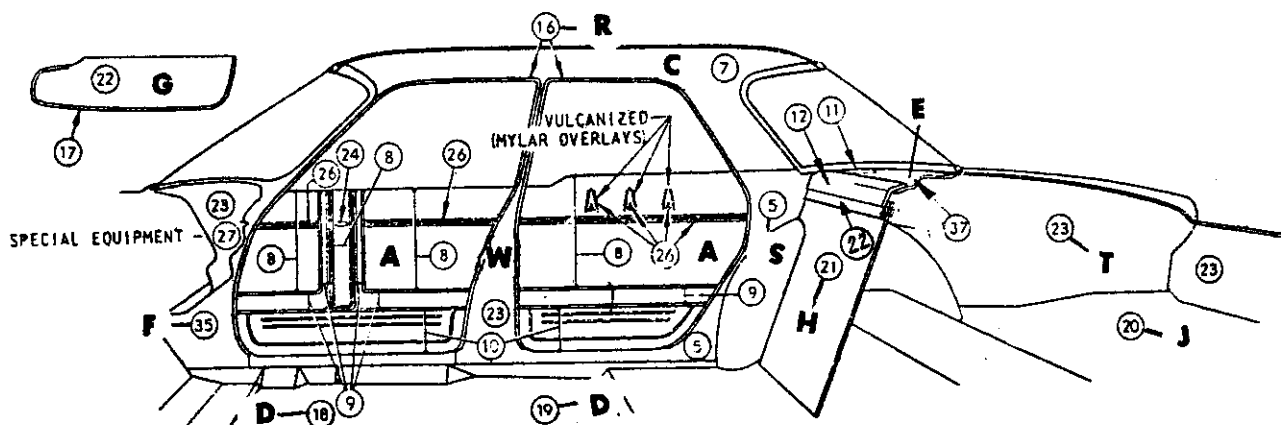

DISTRIBUTION OF MATERIAL

- 3 HEADLINING
- 4 IMITATION LEATHER 28-AM-22
- 5 IMITATION LEATHER 19-C-22
- 7 IMITATION LEATHER 17-C-81 OPT 15.5-C-81
- 8 IMITATION LEATHER 19-DJ-22
- 9 IMITATION LEATHER 18-DN-22
- 10 IMITATION LEATHER .012-L-22
- 11 IMITATION LEATHER 19A-C-22
- 12 IMITATION LEATHER 28A-AM-22
- 16 LACE
- 17 EXTRUDED VINYL
- 18 FLOOR COVERING-FRONT CARPET
- 19 FLOOR COVERING-REAR CARPET
- 20 FLOOR COVERING-LUGG. COMPT. RUBBER
- 21 CARDBOARD
- 22 EMBOSSED CARDBOARD
- 23 PAINT
- 24 METAL
- 25 MOULDING
- 26 MYLAR
- 27 MOULDED RESIN
- 28 MOULDED RUBBER
- 29 MOULDED VINYL
- 32 CARPET
- 33 PLASTIC
- 34 PLASTISOL
- 35 POLYETHYLENE
- 36 EXTRUDED VINYL MYLAR FILLER
- 37 HARDBOARD

Distribution Drawing Legend Page Appears Following Illustration Section

Codes 431, 433

TPM-414

1963 PLYMOUTH TP1-M, TP2-M 4 DOOR SEDAN
IMITATION LEATHER COMBINATION

1963 PLYMOUTH - T SERIES

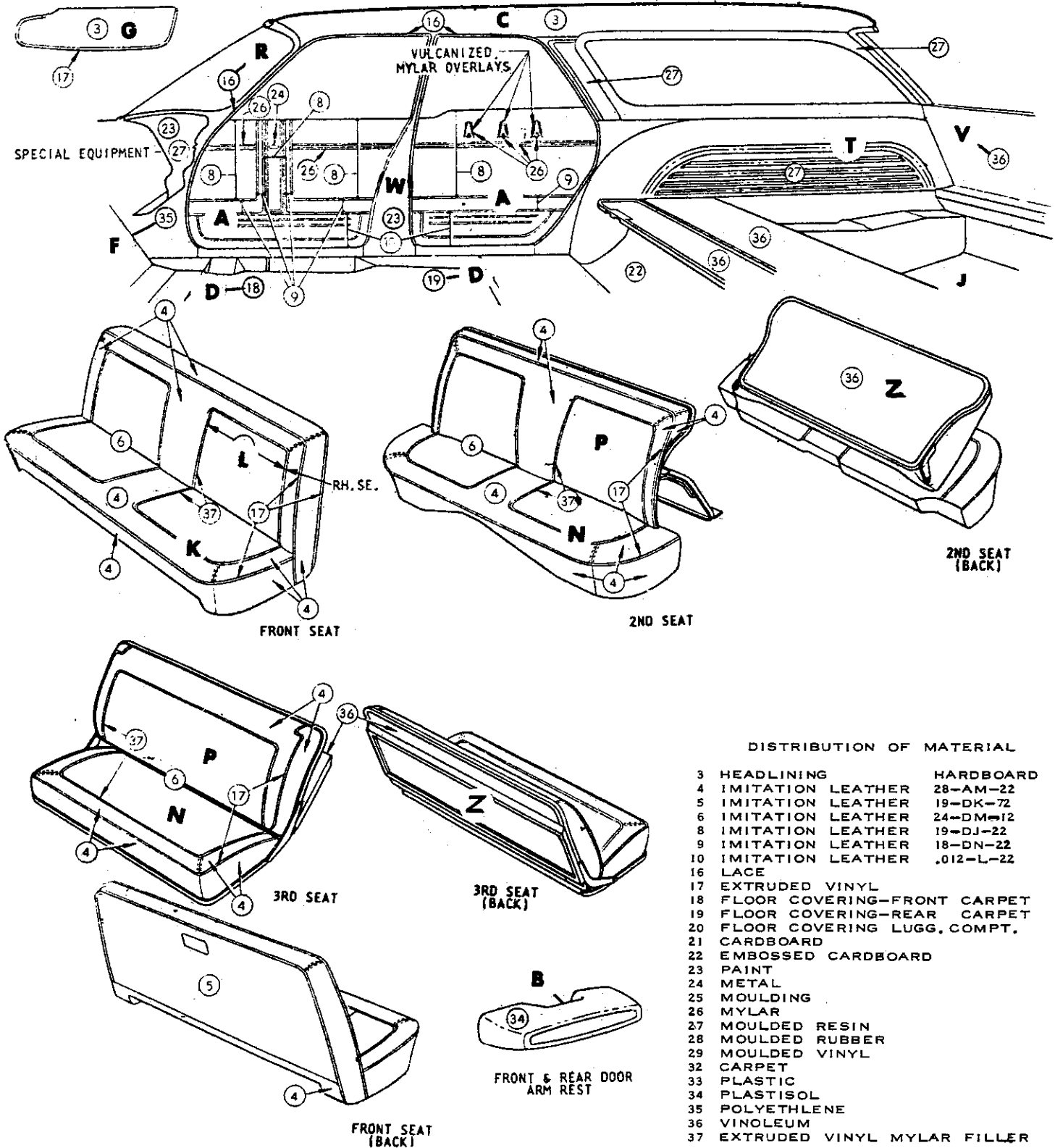

DISTRIBUTION OF MATERIAL

3	HEADLINING	HARDBOARD
4	IMITATION LEATHER	28-AM-22
5	IMITATION LEATHER	19-DK-72
6	IMITATION LEATHER	24-DM-12
8	IMITATION LEATHER	19-DJ-22
9	IMITATION LEATHER	18-DN-22
10	IMITATION LEATHER	.012-L-22
16	LACE	
17	EXTRUDED VINYL	
18	FLOOR COVERING-FRONT CARPET	
19	FLOOR COVERING-REAR CARPET	
20	FLOOR COVERING LUGG. COMPT.	
21	CARDBOARD	
22	EMBOSSED CARDBOARD	
23	PAINT	
24	METAL	
25	MOULDING	
26	MYLAR	
27	MOULDED RESIN	
28	MOULDED RUBBER	
29	MOULDED VINYL	
32	CARPET	
33	PLASTIC	
34	PLASTISOL	
35	POLYETHLENE	
36	VINOLEUM	
37	EXTRUDED VINYL MYLAR FILLER	

Distribution Drawing Legend Page Appears Following Illustration Section Plain Design

Codes 421, 423, 425, 426

TPM-454 1963 PLYMOUTH TP1- M, TP2- M 4 DOOR SUBURBAN IMITATION LEATHER TRIM

1963 PLYMOUTH - T SERIES

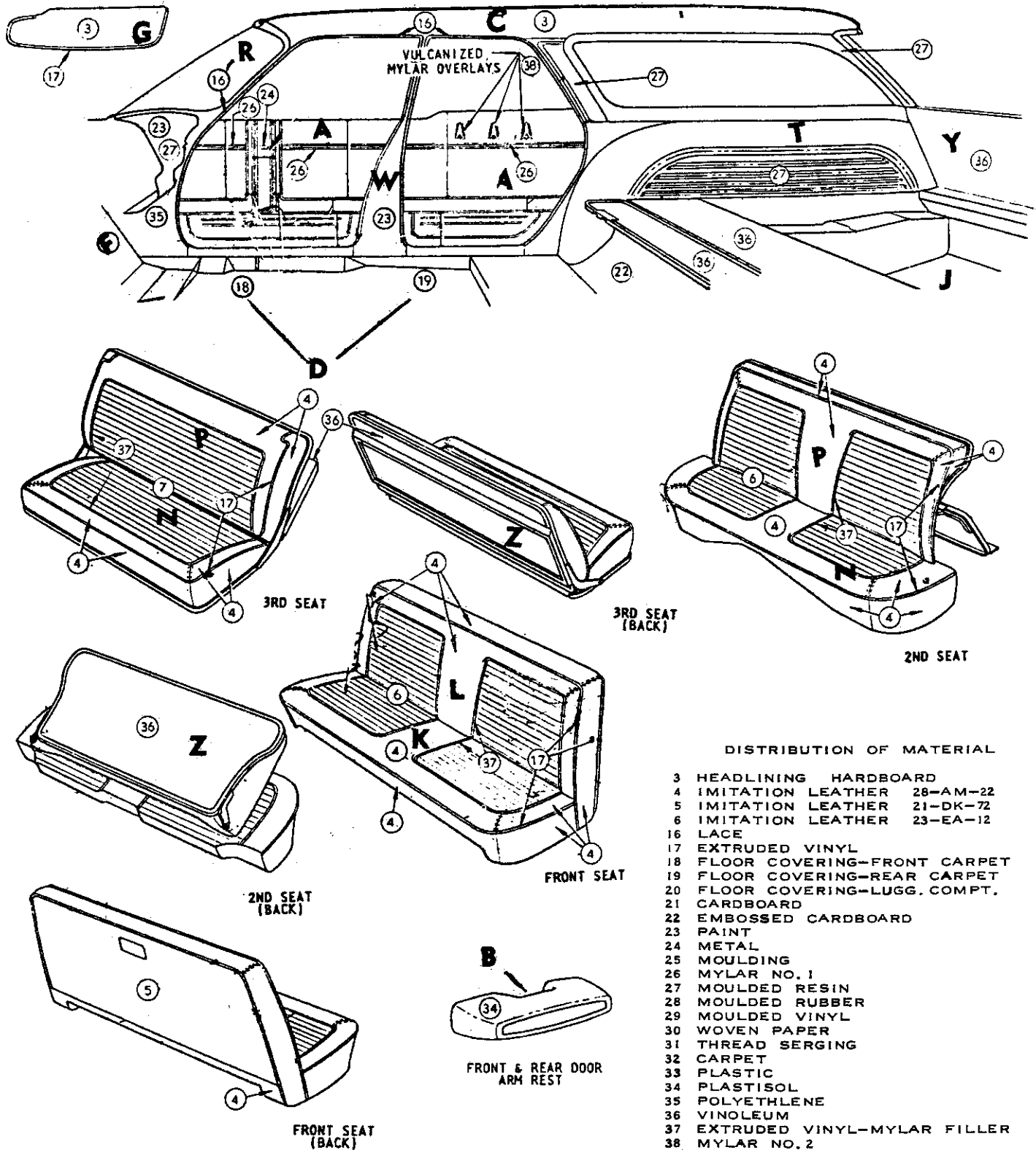

Distribution Drawing Legend Page Appears Following Illustration Section
 Stitched Design

Codes 421, 423, 425, 426

TPM-454 1963 PLYMOUTH TP1-M, TP2-M 4 DOOR STATION WAGON
 IMITATION LEATHER TRIM

1963 PLYMOUTH - T SERIES

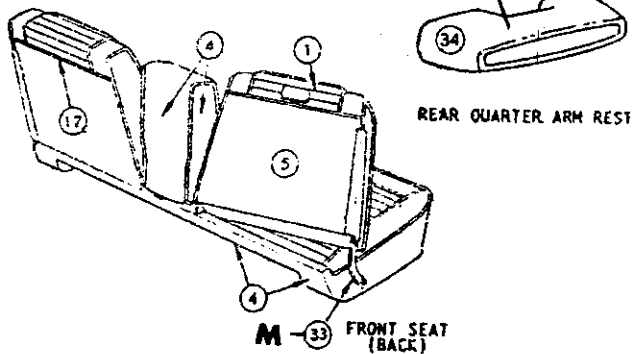
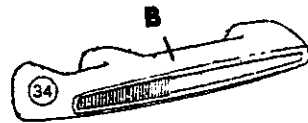
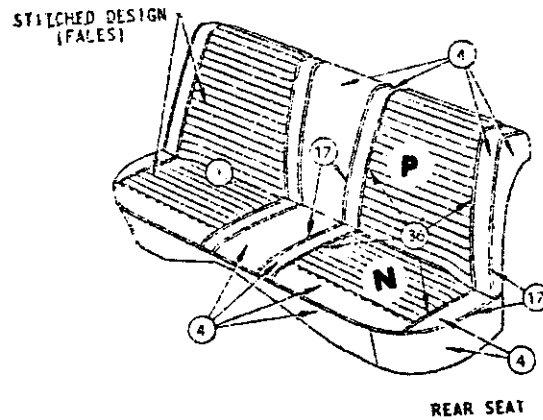
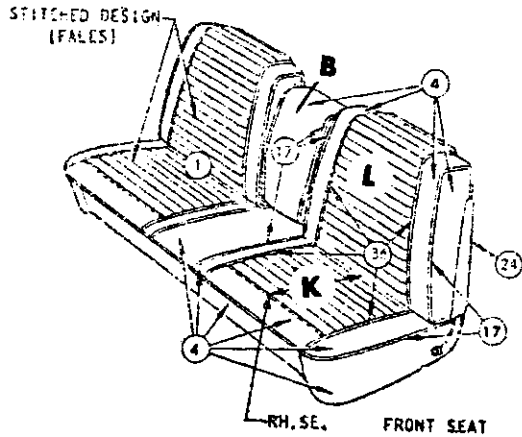
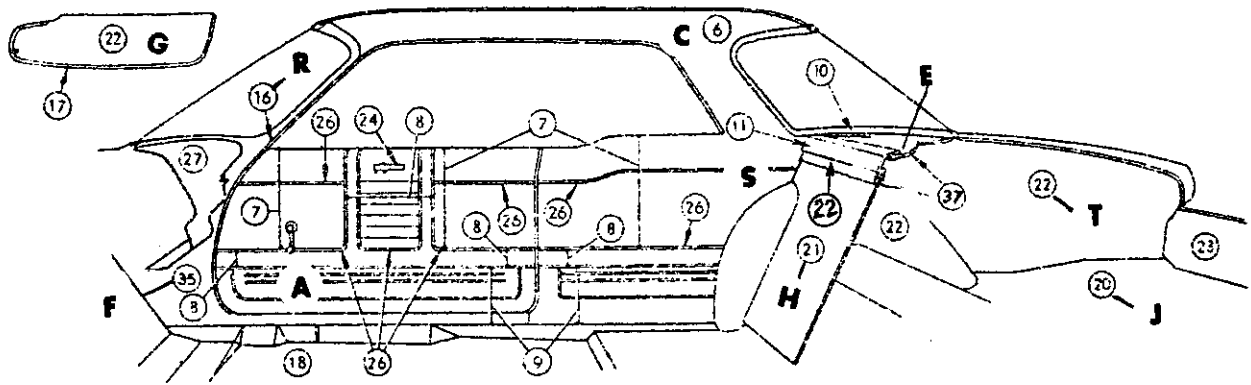

DISTRIBUTION OF MATERIAL

- 1 BODY CLOTH 1
- 4 IMITATION LEATHER 28-AM-22
- 5 IMITATION LEATHER 19-C-22
- 6 IMITATION LEATHER 17-C-81 OPT 15, 5-C-81
- 7 IMITATION LEATHER 19-DJ-22
- 8 IMITATION LEATHER 18-DN-79
- 9 IMITATION LEATHER .012-L-22
- 10 IMITATION LEATHER 19A-C-22
- 11 IMITATION LEATHER 28A-AM-22
- 16 LACE
- 17 EXTRUDED VINYL
- 18 FLOOR COVERING-FRONT CARPET
- 19 FLOOR COVERING-REAR CARPET
- 20 FLOOR COVERING-LUGG. COMPT. RUBBER
- 21 CARDBOARD
- 22 EMBOSSED CARDBOARD
- 23 PAINT
- 24 METAL
- 25 MOULDING
- 26 MYLAR
- 27 MOULDED RESIN
- 28 MOULDED RUBBER
- 29 MOULDED VINYL
- 32 CARPET
- 33 PLASTIC
- 34 PLASTISOL
- 35 POLYETHLENE
- 36 EXTRUDED VINYL MYLAR FILLER
- 37 HARDBOARD

Distribution Drawing Legend Page Appears Following Illustration Section

Codes 341, 342, 343, 345; 346

TPH-231 1963 PLYMOUTH TP1-H, TP2-H SPECIAL CLUB COUPE
CLOTH AND IMITATION LEATHER COMBINATION

1963 PLYMOUTH - T SERIES

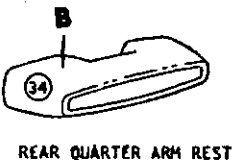
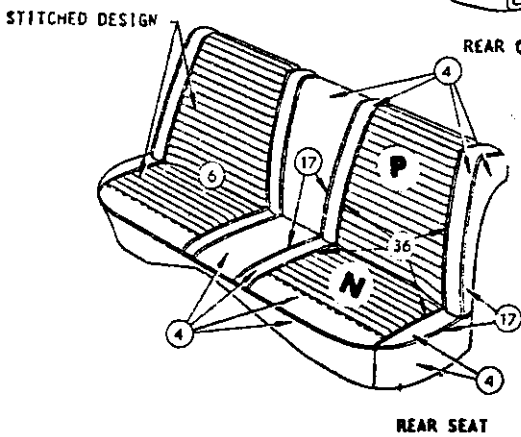
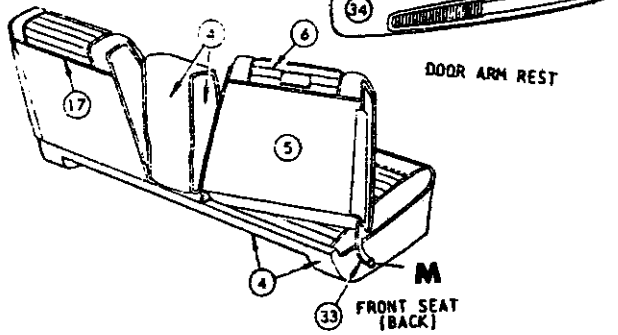
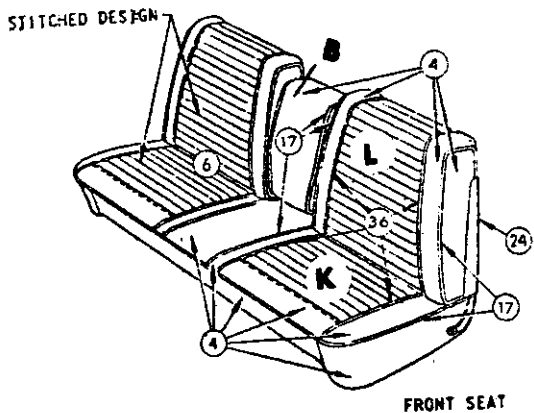
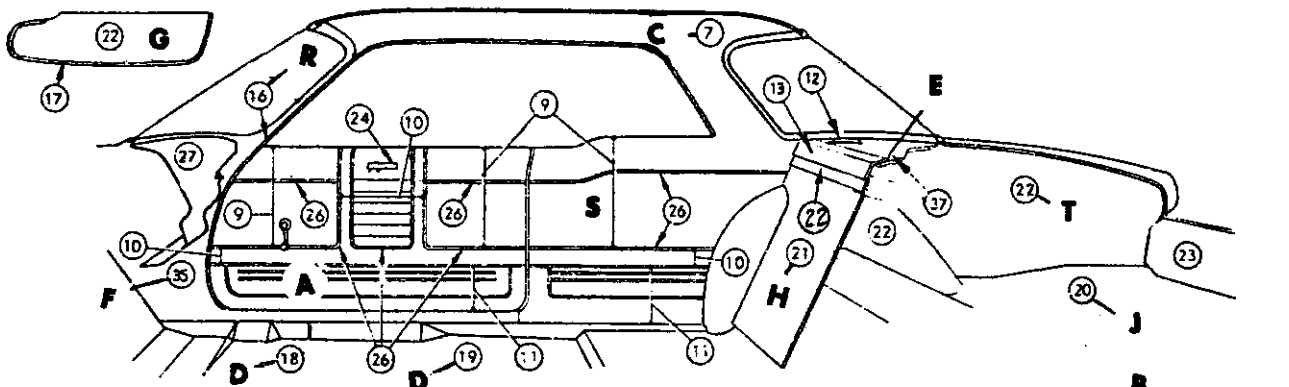

DISTRIBUTION OF MATERIAL

4	IMITATION LEATHER	28-AM-22	
5	IMITATION LEATHER	19-C-22	
6	IMITATION LEATHER	23-DW-79	
7	IMITATION LEATHER	17-C-81	OPT 15, 5-C-81
9	IMITATION LEATHER	19-DJ-22	
10	IMITATION LEATHER	18-DN-79	
11	IMITATION LEATHER	.012-L-22	
12	IMITATION LEATHER	19A-C-22	
13	IMITATION LEATHER	28A-AM-22	
16	LACE		
17	EXTRUDED VINYL		
18	FLOOR COVERING-FRONT CARPET		
19	FLOOR COVERING-REAR CARPET		
20	FLOOR COVERING-LUGG. COMPT. RUBBER		
21	CARDBOARD		
22	EMBOSSED CARDBOARD		
23	PAINT		
24	METAL		
25	MOULDING		
26	MYLAR		
27	MOULDED RESIN		
28	MOULDED RUBBER		
29	MOULDED VINYL		
32	CARPET		
33	PLASTIC		
34	PLASTISOL		
35	POLYETHYLENE		
36	EXTRUDED VINYL MYLAR FILLER		
37	HARDBOARD		

Distribution Drawing Legend Page Appears Following Illustration Section

Codes 441, 443, 445

TPH-234 1963 PLYMOUTH TP1-H, TP2-H SPECIAL CLUB COUPE
IMITATION LEATHER COMBINATION

1963 PLYMOUTH - T SERIES

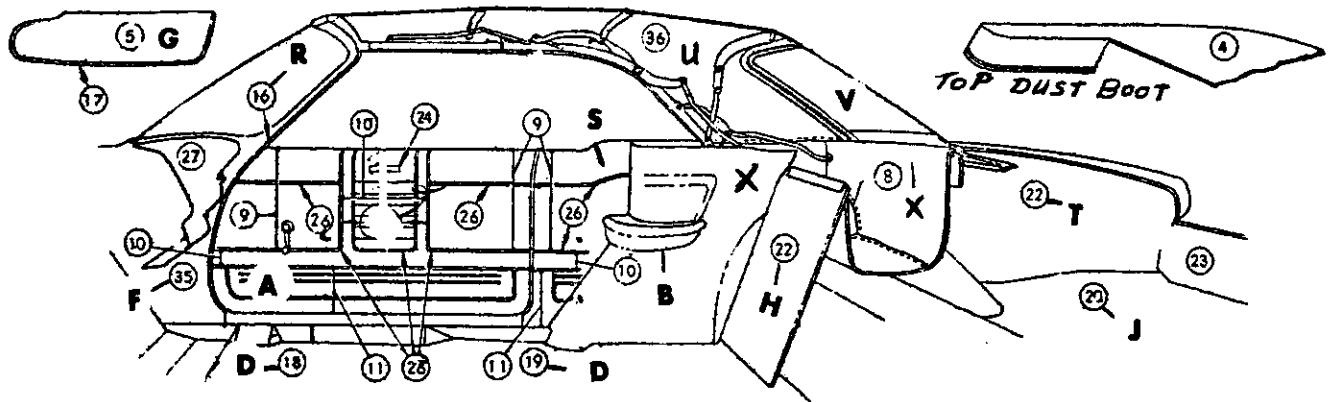

STITCHED DESIGN

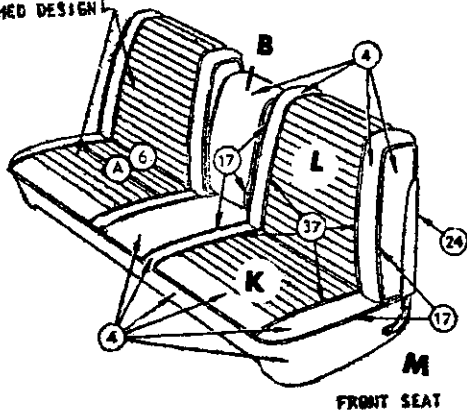

FRONT SEAT

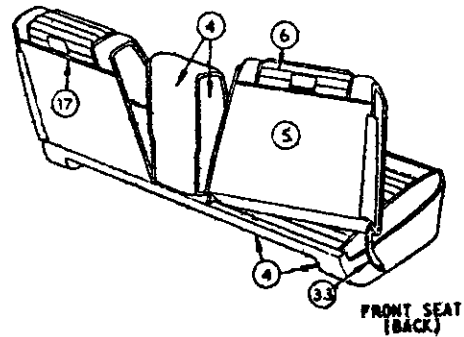

FRONT SEAT (BACK)

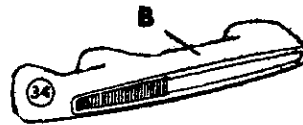

DOOR ARM REST

STITCHED-DESIGN

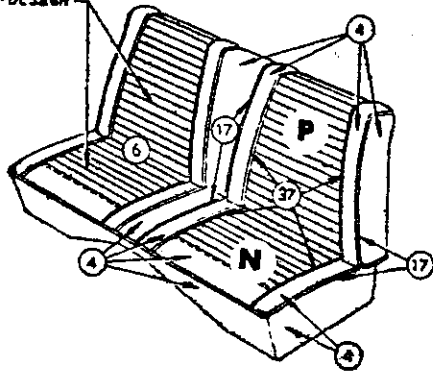

REAR SEAT

DISTRIBUTION OF MATERIAL

4	IMITATION LEATHER	28-AM-22
5	IMITATION LEATHER	19-C-22
6	IMITATION LEATHER	23-DW-79
8	IMITATION LEATHER	19B-C-22
9	IMITATION LEATHER	19-DJ-22
10	IMITATION LEATHER	18-DN-79
11	IMITATION LEATHER	.012-L-22
16	LACE	
17	EXTRUDED VINYL	
18	FLOOR COVERING-FRONT CARPET	
19	FLOOR COVERING-REAR CARPET	
20	FLOOR COVERING-LUGG. COMPT. RUBBER	
21	CARDBOARD	
22	EMBOSSED CARDBOARD	
23	PAINT	
24	METAL	
25	MOULDING	
26	MYLAR	
27	MOULDED RESIN	
28	MOULDED RUBBER	
29	MOULDED VINYL	
32	CARPET	
33	PLASTIC	
34	PLASTISOL	
35	POLYETHLENE	
36	TOP MATERIAL	
37	EXTRUDED VINYL MYLAR FILLER	

Distribution Drawing Legend Page Appears Following Illustration Section

Codes 441, 443, 445, 446

TPH-274

1963 PLYMOUTH TP2-H CONVERTIBLE COUPE
IMITATION LEATHER TRIM

1963 PLYMOUTH - T SERIES

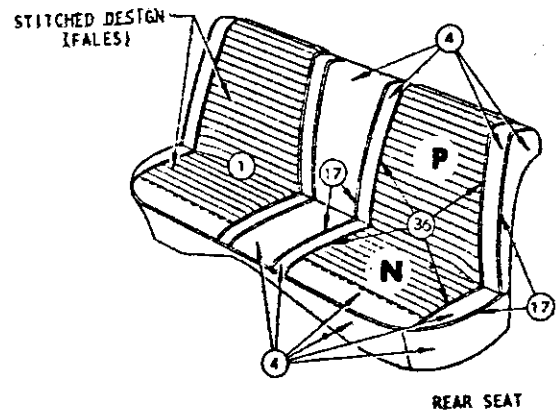
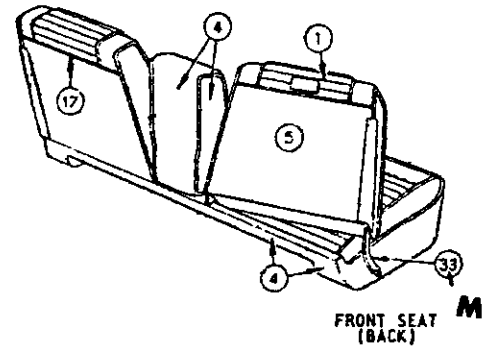
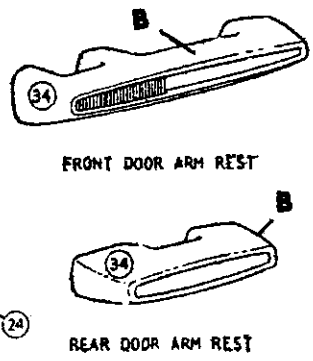
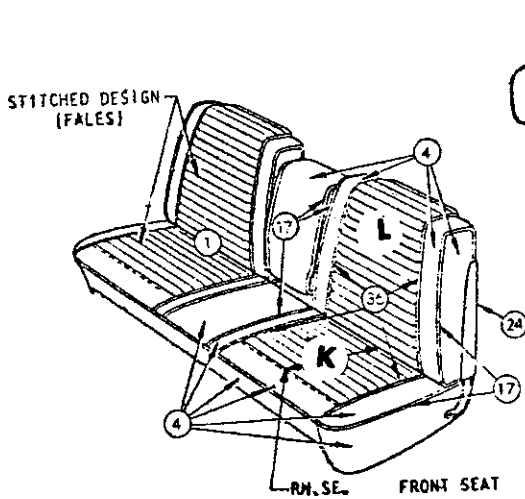
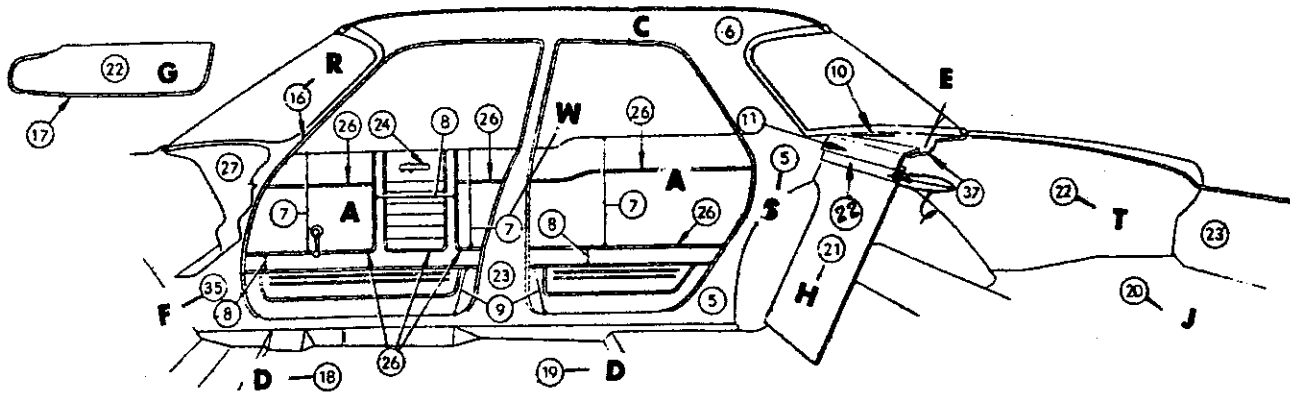

DISTRIBUTION OF MATERIAL

1	BODY CLOTH	1
4	IMITATION LEATHER	28-AM-22
5	IMITATION LEATHER	19-C-22
6	IMITATION LEATHER	17-C-81 OPT 15, 5-C-81
7	IMITATION LEATHER	19-DJ-22
8	IMITATION LEATHER	18-DN-79
9	IMITATION LEATHER	.012-L-22
10	IMITATION LEATHER	19A-C-22
11	IMITATION LEATHER	28A-AM-22
16	LACE	
17	EXTRUDED VINYL	
18	FLOOR COVERING-FRONT CARPET	
19	FLOOR COVERING-REAR CARPET	
20	FLOOR COVERING-LUGG. COMPT. RUBBER	
21	CARDBOARD	
22	EMBOSSED CARDBOARD	
23	PAINT	
24	METAL	
25	MOULDING	
26	MYLAR	
27	MOULDED RESIN	
28	MOULDED RUBBER	
29	MOULDED VINYL	
32	CARPET	
33	PLASTIC	
34	PLASTISOL	
35	POLYETHLENE	
36	EXTRUDED VINYL MYLAR FILLER	
37	HARDBOARD	

Distribution Drawing Legend Page Appears Following Illustration Section

Codes 341, 342, 343, 345, 346

TPH-411

1963 PLYMOUTH TP1-H, TP2-H 4 DOOR SEDAN
CLOTH AND IMITATION LEATHER COMBINATION

1963 PLYMOUTH - T SERIES

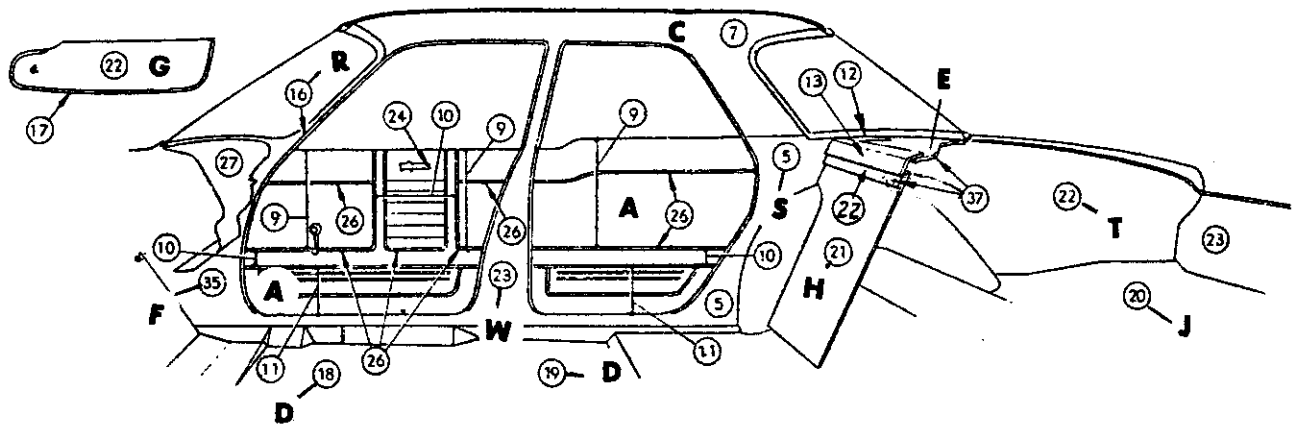

STITCHED DESIGN

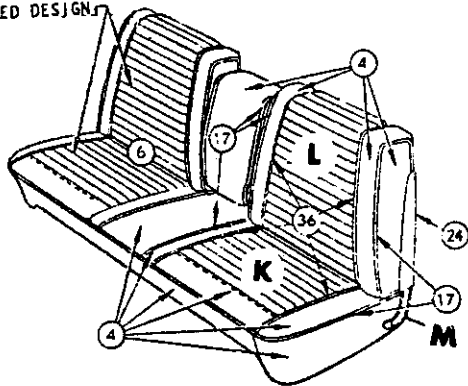

FRONT SEAT

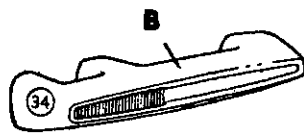

FRONT DOOR ARM REST



REAR DOOR ARM REST

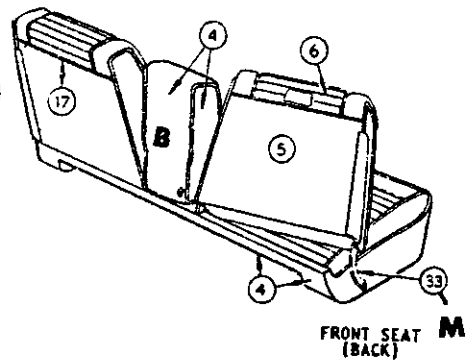

FRONT SEAT (BACK) M

STITCHED DESIGN

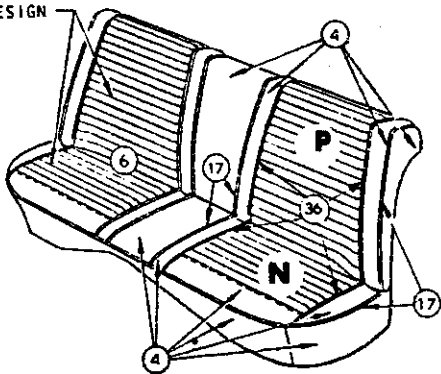

REAR SEAT

DISTRIBUTION OF MATERIAL

4	IMITATION LEATHER	28-AM-22
5	IMITATION LEATHER	19-C-22
6	IMITATION LEATHER	23-DW-79
7	IMITATION LEATHER	17-C-81 OPT 15, 5-C-81
9	IMITATION LEATHER	19-DJ-22
10	IMITATION LEATHER	18-DN-79
11	IMITATION LEATHER	.012-L-22
12	IMITATION LEATHER	19A-C-22
13	IMITATION LEATHER	28A-AM-22
16	LACE	
17	EXTRUDED VINYL	
18	FLOOR COVERING-FRONT CARPET	
19	FLOOR COVERING-REAR CARPET	
20	FLOOR COVERING-LUGG. COMPT., RUBBER	
21	CARDBOARD	
22	EMBOSSED CARDBOARD	
23	PAINT	
24	METAL	
25	MOULDING	
26	MYLAR	
27	MOULDED RESIN	
28	MOULDED RUBBER	
29	MOULDED VINYL	
32	CARPET	
33	PLASTIC	
34	PLASTISOL	
35	POLYETHYLENE	
36	EXTRUDED VINYL MYLAR FILLER	
37	HARDBOARD	

Distribution Drawing Legend Page Appears Following Illustration Section

Codes 441, 443, 445

TPH-414

1963 PLYMOUTH TP1-H, TP2-H 4 DOOR SEDAN
IMITATION LEATHER COMBINATION

1963 PLYMOUTH - T SERIES

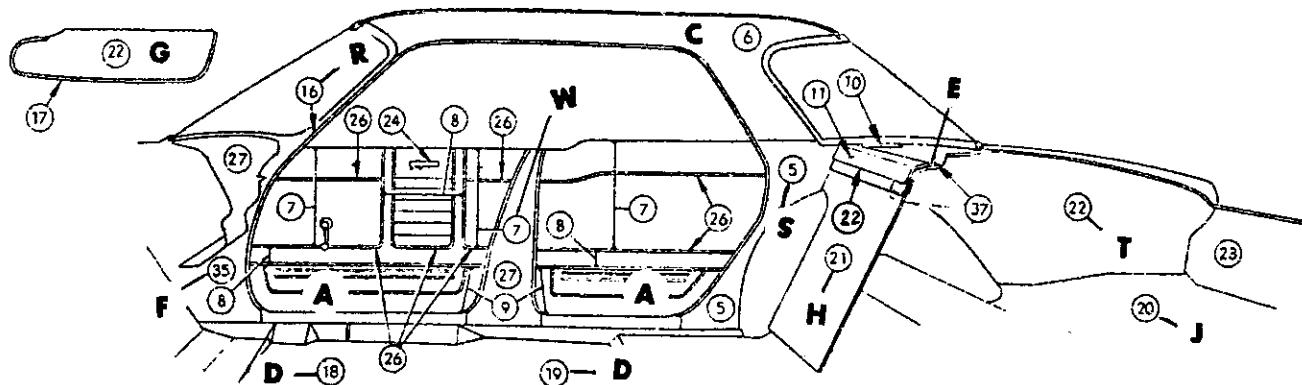

STITCHED DESIGN (FALES)

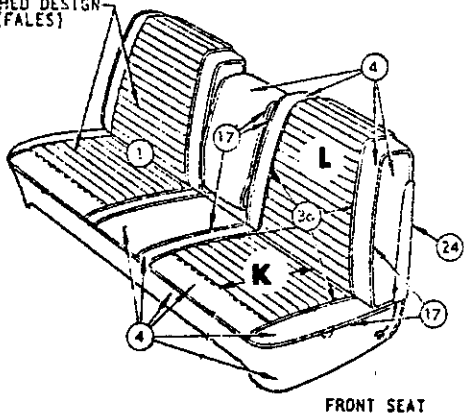

FRONT SEAT

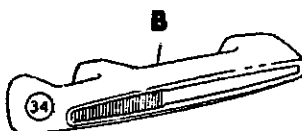

FRONT DOOR ARM REST

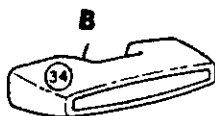

REAR DOOR ARM REST

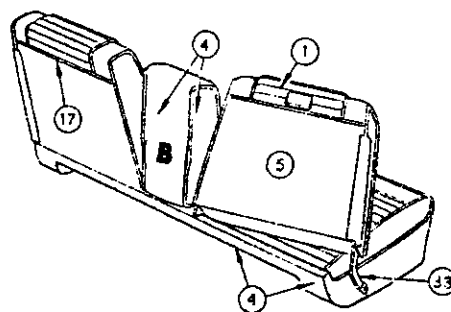

FRONT SEAT (BACK)

DISTRIBUTION OF MATERIAL

- 1 BODY CLOTH
- 4 IMITATION LEATHER
- 5 IMITATION LEATHER
- 6 IMITATION LEATHER
- 7 IMITATION LEATHER
- 8 IMITATION LEATHER
- 9 IMITATION LEATHER
- 10 IMITATION LEATHER
- 11 IMITATION LEATHER
- 16 LACE
- 17 EXTRUDED VINYL
- 18 FLOOR COVERING-FRONT CARPET
- 19 FLOOR COVERING-REAR CARPET
- 20 FLOOR COVERING-LUGG. COMPT. RUBBER
- 21 CARDBOARD
- 22 EMBOSSED CARDBOARD
- 23 PAINT
- 24 METAL
- 25 MOULDING
- 26 MYLAR
- 27 MOULDED RESIN
- 28 MOULDED RUBBER
- 29 MOULDED VINYL
- 32 CARPET
- 33 PLASTIC
- 34 PLASTISOL
- 35 POLYETHYLENE
- 36 EXTRUDED VINYL MYLAR FILLER
- 37 HARDBOARD
- 28-AM-22
- 19-C-22
- 17-C-81 OPT 15.5-C-81
- 19-DJ-22
- 18-DN-79
- .012-L-22
- 19A-C-22
- 28A-AM-22

STITCHED DESIGN (FALES)

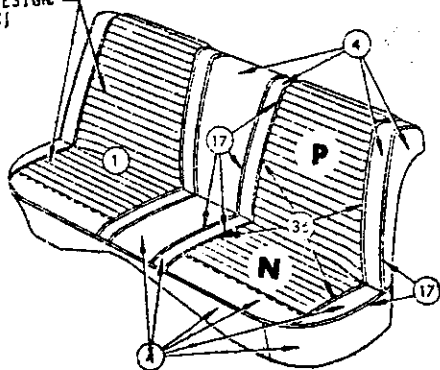

REAR SEAT

Distribution Drawing Legend Page Appears Following Illustration Section

Codes 341, 342, 343, 345, 346

TPH-433 1963 PLYMOUTH TP1-H, TP2-H SPECIAL 4 DOOR SEDAN
CLOTH AND IMITATION LEATHER COMBINATION

1963 PLYMOUTH-T SERIES

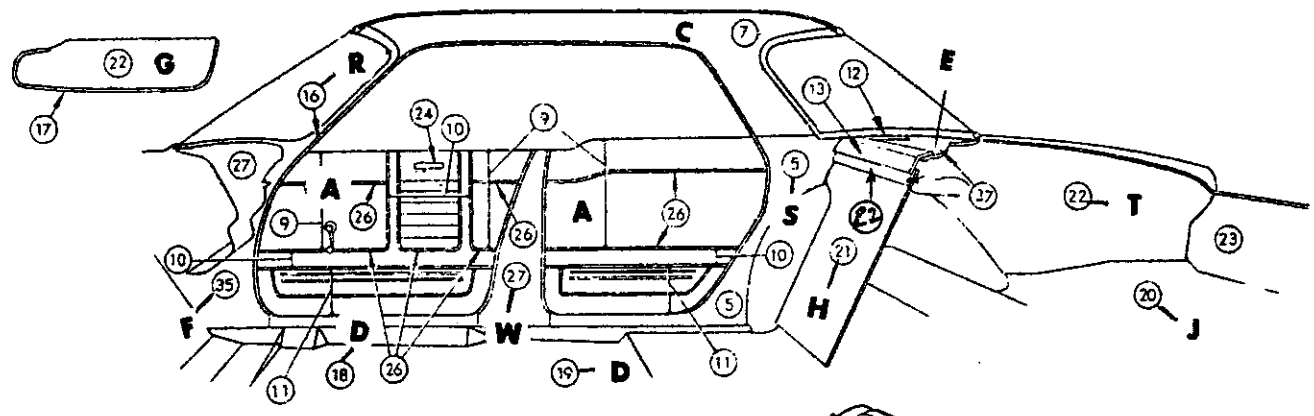

STITCHED DESIGN

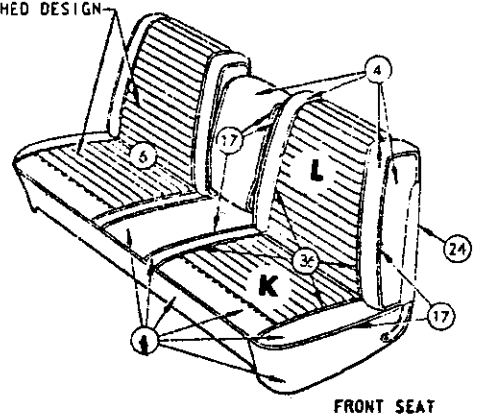

FRONT SEAT

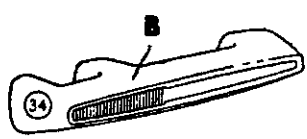

FRONT DOOR ARM REST

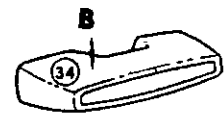

REAR DOOR ARM REST

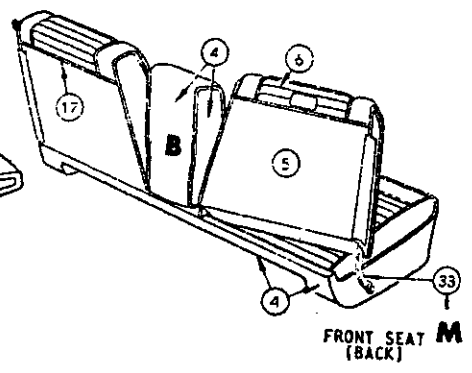

FRONT SEAT (BACK)

STITCHED DESIGN

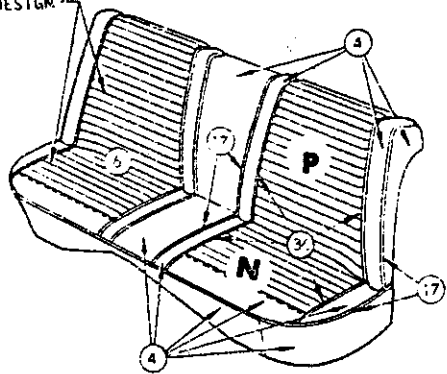

REAR SEAT

DISTRIBUTION OF MATERIAL

- 4 IMITATION LEATHER 28-AM-22
- 5 IMITATION LEATHER 19-C-22
- 6 IMITATION LEATHER 23-DW-79
- 7 IMITATION LEATHER 17-C-81 OPT 15.5-C-81
- 9 IMITATION LEATHER 19-DJ-22
- 10 IMITATION LEATHER 18-DN-79
- 11 IMITATION LEATHER .012-L-22
- 12 IMITATION LEATHER 19A-C-22
- 13 IMITATION LEATHER 28A-AM-22
- 16 LACE
- 17 EXTRUDED VINYL
- 18 FLOOR COVERING-FRONT CARPET
- 19 FLOOR COVERING-REAR CARPET
- 20 FLOOR COVERING-LUGG. COMPT. RUBBER
- 21 CARDBOARD
- 22 EMBOSSED CARDBOARD
- 23 PAINT
- 24 METAL
- 25 MOULDING
- 26 MYLAR
- 27 MOULDED RESIN
- 28 MOULDED RUBBER
- 29 MOULDED VINYL
- 32 CARPET
- 33 PLASTIC
- 34 PLASTISOL
- 35 POLYETHYLENE
- 36 EXTRUDED VINYL MYLAR FILLER
- 37 HARDBOARD

Distribution Drawing Legend Page Appears Following Illustration Section

Codes 441, 443, 445, 446

TPH-434 1963 PLYMOUTH TP1-H, TP2-H SPECIAL 4 DOOR SEDAN IMITATION LEATHER COMBINATION

1963 PLYMOUTH - T SERIES

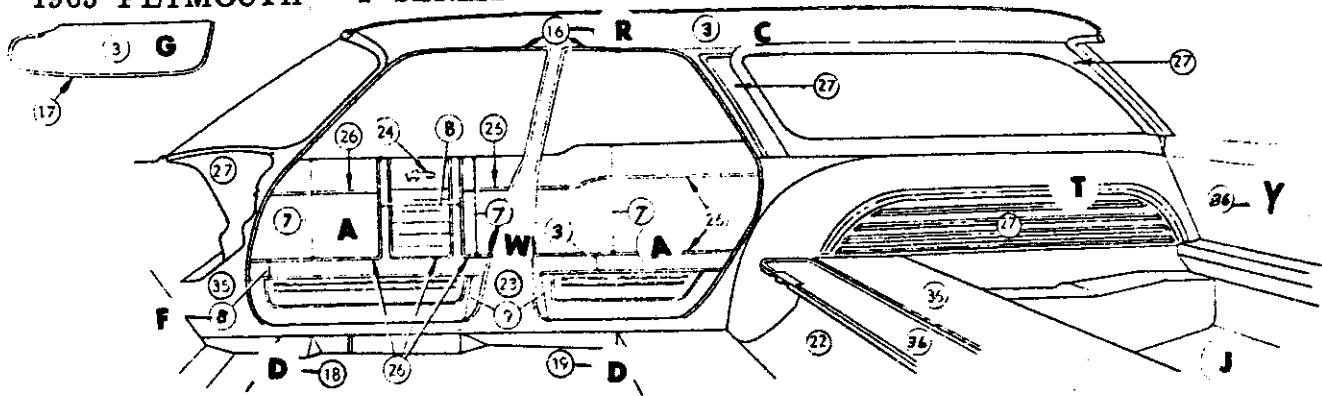

STITCHED DESIGN (FALES)

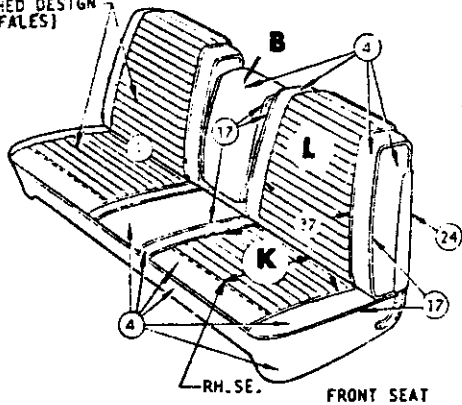

RH. SE. FRONT SEAT

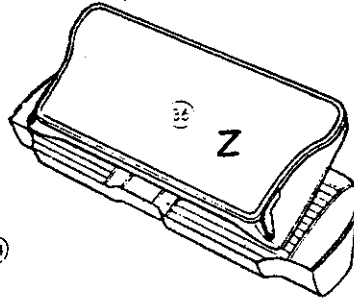

2ND SEAT (BACK)

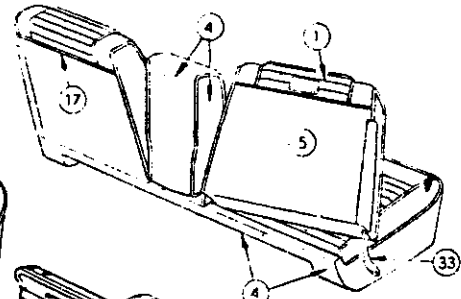

FRONT SEAT (BACK)

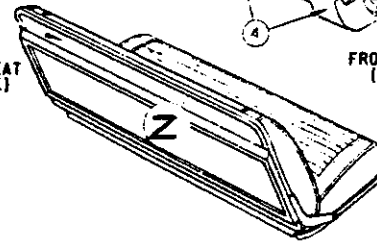

3RD SEAT (BACK)

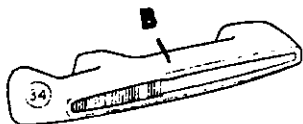

FRONT DOOR ARM REST

STITCHED DESIGN

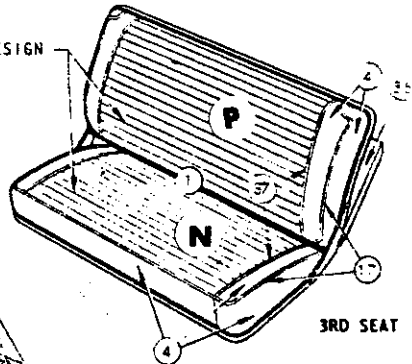

3RD SEAT

STITCHED DESIGN (FALES)

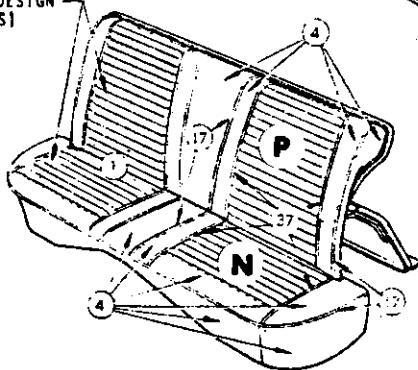

2ND SEAT

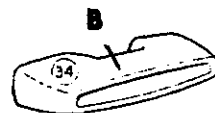

REAR DOOR ARM REST

DISTRIBUTION OF MATERIAL

- 1 BODY CLOTH I
- 3 HEADLINING
- 4 IMITATION LEATHER 28-AM-22
- 5 IMITATION LEATHER 19-C-22
- 7 IMITATION LEATHER 19-DJ-22
- 8 IMITATION LEATHER 18-DN-79
- 9 IMITATION LEATHER .012-L-22
- 16 LACE
- 17 EXTRUDED VINYL
- 18 FLOOR COVERING-FRONT CARPET
- 19 FLOOR COVERING-REAR CARPET
- 20 FLOORBOARD
- 21 CARDBOARD
- 22 EMBOSSED CARDBOARD
- 23 PAINT
- 24 METAL
- 25 MOULDING
- 26 MYLAR
- 27 MOULDED RESIN
- 28 MOULDED RUBBER
- 29 MOULDED VINYL
- 32 CARPET
- 33 PLASTIC
- 34 PLASTISOL
- 35 POLYETHLENE
- 36 VINOLEUM
- 37 EXTRUDED VINYL MYLAR FILLER

Distribution Drawing Legend Page Appears Following Illustration Section

Codes 341, 342, 343, 345, 346

TPH-451

1963 PLYMOUTH TP1-H, TP2-H 4 DOOR SUBURBAN
CLOTH AND IMITATION LEATHER COMBINATION

1963 PLYMOUTH - T SERIES

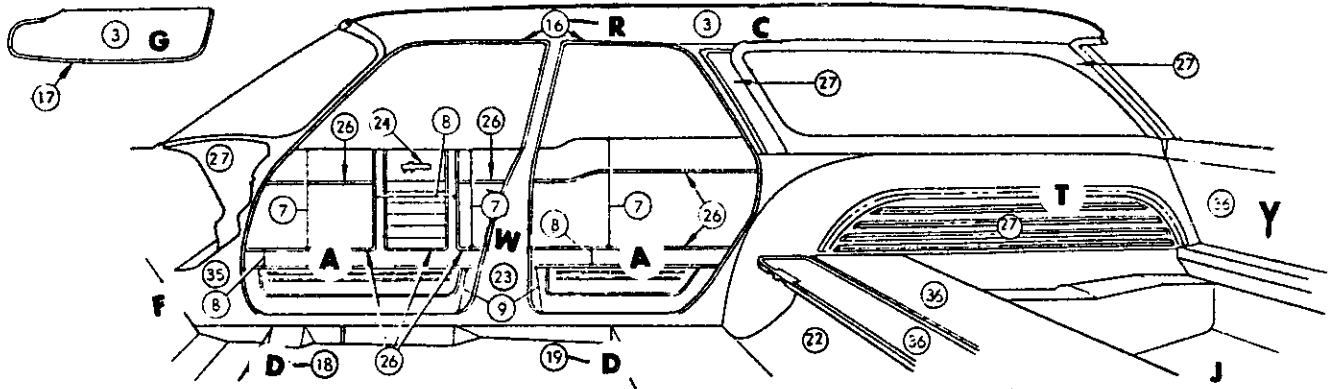

STITCHED DESIGN (FALES)

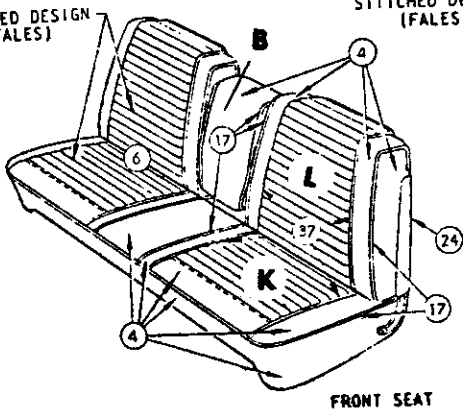

FRONT SEAT

STITCHED DESIGN (FALES)

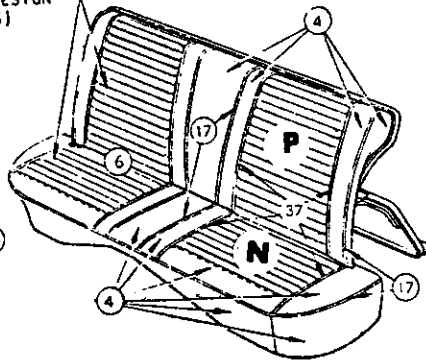

2ND SEAT

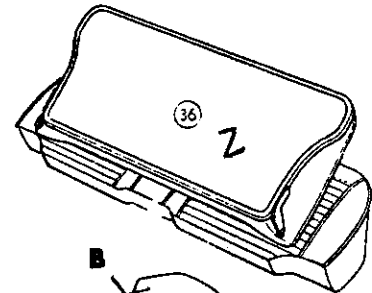

REAR DOOR ARM REST

2ND SEAT (BACK)

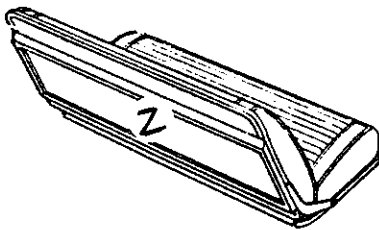

3RD SEAT (BACK)

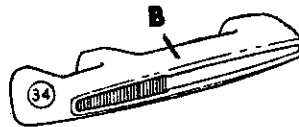

FRONT DOOR ARM REST

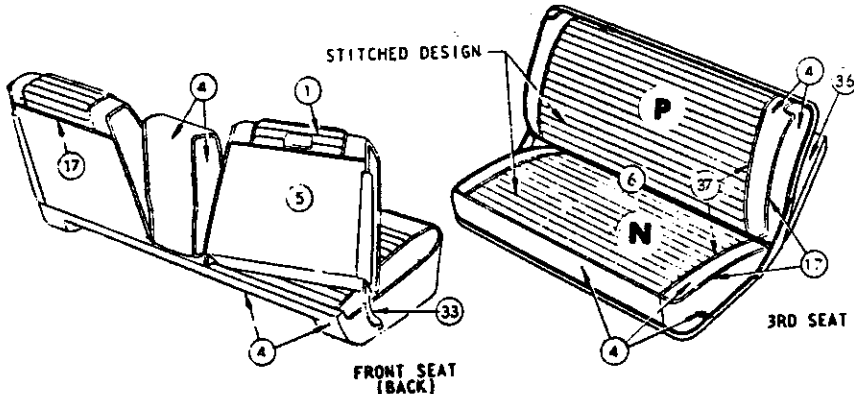

FRONT SEAT (BACK)

3RD SEAT

DISTRIBUTION OF MATERIAL

3 HEADLINING	HARDBOARD
4 IMITATION LEATHER	28-AM-22
5 IMITATION LEATHER	19-C-22
6 IMITATION LEATHER	23-DW-79
7 IMITATION LEATHER	19-DJ-22
8 IMITATION LEATHER	18-DN-79
9 IMITATION LEATHER	.012-L-22
16 LACE	
17 EXTRUDED VINYL	
18 FLOOR COVERING-FRONT CARPET	
19 FLOOR COVERING-REAR CARPET	
20 FLOOR COVERING-LUGG. COMPT.	
22 EMBOSSED CARDBOARD	
23 PAINT	
24 METAL	
25 MOULDING	
26 MYLAR	
27 MOULDED RESIN	
28 MOULDED RUBBER	
29 MOULDED VINYL	
32 CARPET	
33 PLASTIC	
34 PLASTISOL	
35 POLYETHLENE	
36 VINOLEUM	
37 EXTRUDED VINYL MYLAR FILLER	

Distribution Drawing Legend Page Appears Following Illustration Section

Codes 441, 442, 443, 445, 446, 447

TPH-454

1963 PLYMOUTH TP1-H, TP2-H 4 DOOR SUBURBAN
IMITATION LEATHER COMBINATION

1963 PLYMOUTH -T SERIES

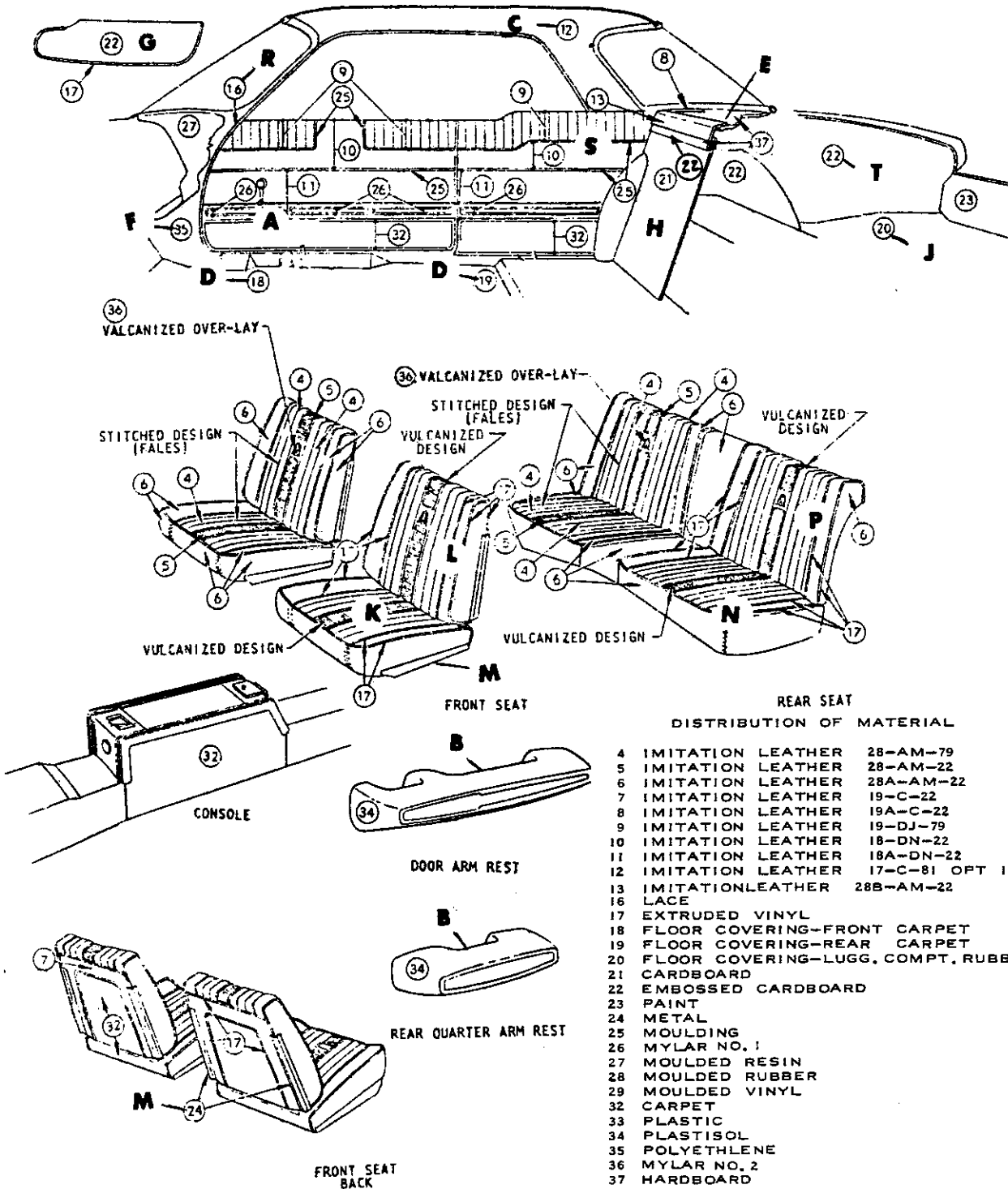

Distribution Drawing Legend Page Appears Following Illustration Section

Codes 451, 455, 459

TPP-234

1963 PLYMOUTH TP2-P SPECIAL CLUB COUPE
IMITATION LEATHER COMBINATION

1963 PLYMOUTH - T SERIES

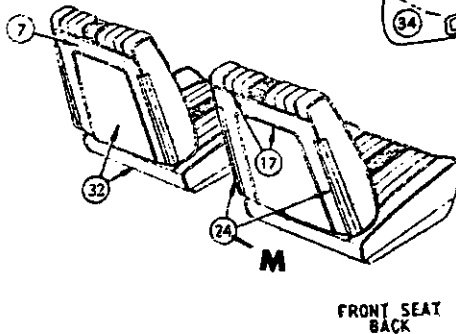
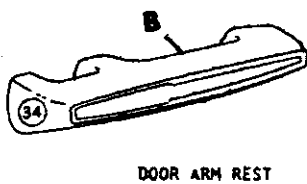
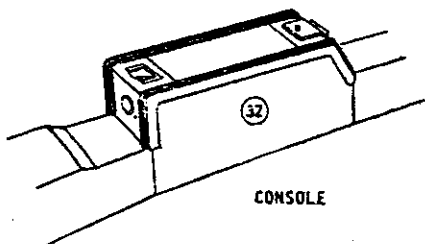
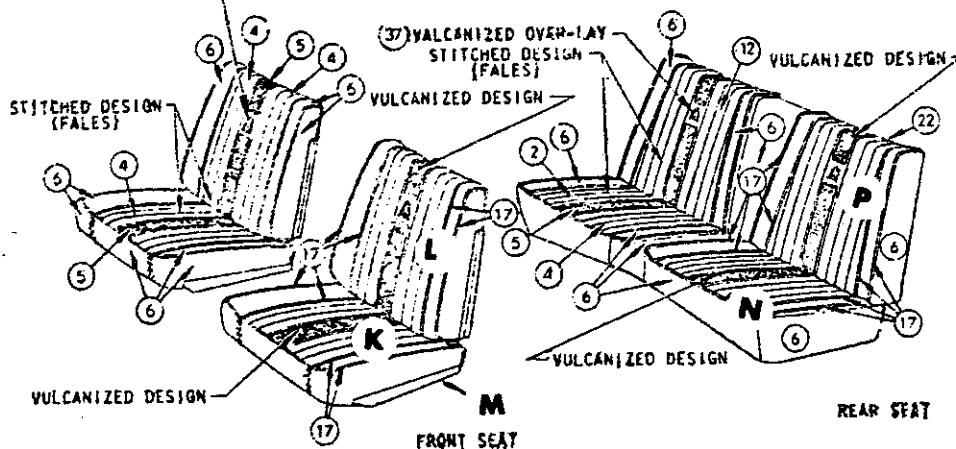
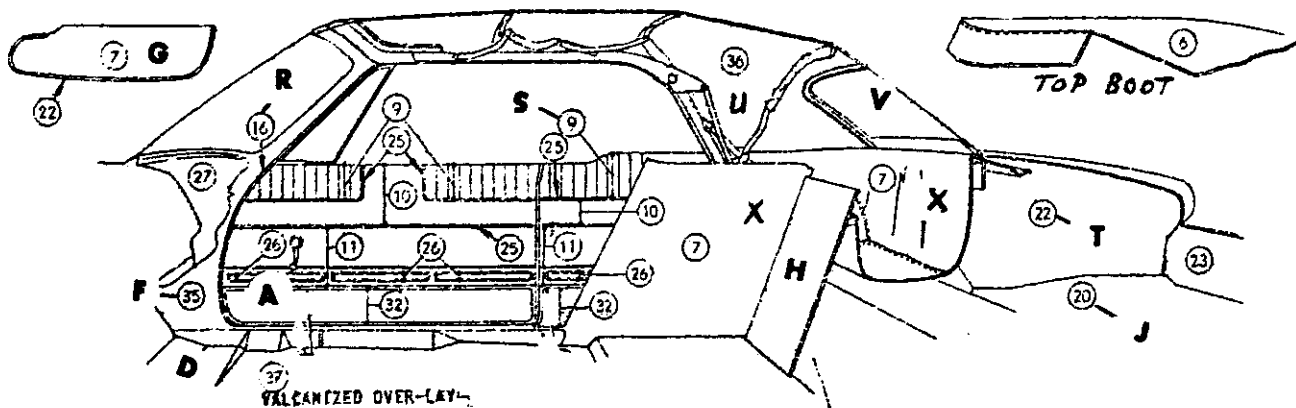

DISTRIBUTION OF MATERIAL

4	IMITATION LEATHER	28-AM-79
5	IMITATION LEATHER	28-AM-22
6	IMITATION LEATHER	28A-AM-22
7	IMITATION LEATHER	19-C-22
8	IMITATION LEATHER	19A-C-22
9	IMITATION LEATHER	19-DJ-79
10	IMITATION LEATHER	18-DN-22
11	IMITATION LEATHER	18A-DN-22
12	IMITATION LEATHER	23-DW-79
16	LACE	
17	EXTRUDED VINYL	
18	FLOOR COVERING-FRONT CARPET	
19	FLOOR COVERING-REAR CARPET	
20	FLOOR COVERING-LUGG. COMPT. RUBBER	
21	CARDBOARD	
22	EMBOSSED CARDBOARD	
23	PAINT	
24	METAL	
25	MOULDING	
26	MYLAR NO. 1	
27	MOULDED RESIN	
28	MOULDED RUBBER	
29	MOULDED VINYL	
32	CARPET	
33	PLASTIC	
34	PLASTISOL	
35	POLYETHLENE	
36	TOP MATERIAL	
37	MYLAR NO. 2	

Distribution Drawing Legend Page Appears Following Illustration Section

Codes 451, 455, 459

TPP-274

1963 PLYMOUTH TP2-P CONVERTIBLE COUPE
IMITATION LEATHER COMBINATION

1963 PLYMOUTH - T SERIES

Distribution Drawing Legend

See Illustrations For Letter Identification

Letter	Description	Code
A	Panel, Door Trim	23-92-5
B	Arm Rest, Door, Front	23-76-3
	Center, Front Seat	23-76-34
	Door, Rear	23-76-59
	Quarter Panel	23-76-66
C	Headlining	23-86-3
D	Floor Cover, Front, Carpet	23-79-3
	Rubber	23-20-8
	Rear. Carpet	23-79-33
	Rubber	23-20-41
E	Panel, Shelf Trim	23-102-3
F	Panel, Cowl Trim	23-91-6
G	Visor	23-103-3
H	Panel, Luggage Compartment Front	23-96-3
J	Cover, Luggage Compartment Floor	23-20-29
K	Cover, Front Seat Cushion	23-108-5
L	Cover, Front Seat Back	23-108-16
M	Cover, Front Seat Hinge	23-108-84
N	Cover, Rear Seat Cushion	23-109-36
P	Cover, Rear Seat Back	23-109-4
Q	Cover, Rear Seat Cushion Bottom Panel	23-109-40
R	Weathercord, Door	23-113-2
	Hinge Pillar	23-113-25
	Lock Pillar	23-113-30
	w/Weatherstrip	23-66-33
S	Panel, Quarter Trim	23-101-3
T	Cover, Wheelhouse	23-96-8
U	Top Deck and Side Quarter	23-112-108
V	Curtain, Folding Top Back	23-112-45
W	Cover, Center Pillar	23-99-4
X	Panel, Folding Top Well Pocket	23-112-153
Y	Cover, Tailgate Inside Panel	23-79-79
Z	Cover, Rear Seat Back Panel	23-109-5

BODY CODE

COLUMN LEGEND

SAVOY (TP1-L)

201 (21)	2 D. Sedan (Fleet)
203 (41)	4 D. Sedan (Fleet)
211 (21)	2 D. Sedan
213 (41)	4 D. Sedan
256 (45A)	4 D. Wagon (2 Seat)
257 (45B)	4 D. Wagon (3 Seat)
283 (41)	4 D. Sedan (Taxi)
291 (21)	2 D. Sedan (Police)
293 (41)	4 D. Sedan (Police)
296 (45A)	4 D. Wagon (Police-2 Seat)

BELVEDERE (TP1-M)

221 (21)	2 D. Sedan
222 (23)	2 D. Hard Top
223 (41)	4 D. Sedan

FURY (TP1-H)

232 (23)	2 D. Hard Top
233 (41)	4 D. Sedan

SAVOY (TP2-L)

301 (21)	2 D. Sedan (Fleet)
303 (41)	4 D. Sedan (Fleet)
311 (21)	2 D. Sedan
313 (41)	4 D. Sedan
356 (45A)	4 D. Wagon (2 Seat)
357 (45B)	4 D. Wagon (3 Seat)
383 (41)	4 D. Sedan (Taxi)
391 (21)	2 D. Sedan (Police)
393 (41)	4 D. Sedan (Police)
396 (45A)	4 D. Wagon (Police-2 Seat)

BELVEDERE (TP2-M)

321 (21)	2 D. Sedan
322 (23)	2 D. Hard Top
323 (41)	4 D. Sedan
366 (45A)	4 D. Wagon (2 Seat)
367 (45B)	4 D. Wagon (3 Seat)

FURY (TP2-H)

332 (23)	2 D. Hard Top
333 (41)	4 D. Sedan
334 (43)	4 D. Hard Top
335 (27)	Convertible
376 (45A)	4 D. Wagon (2 Seat)
377 (45B)	4 D. Wagon (3 Seat)

SPORT FURY (TP2-P)

342 (23)	2 D. Hard Top
345 (27)	Convertible

★ Indicates use as required.
 ☐ Indicates parts not listed in any previous parts book.
 Right and left part numbers are on same line,
 first number is right, second number is left.

Printed in U.S.A.
 Prices and specifications subject to change without notice.
 September 4, 1962.

CONVERTIBLE TOP COLOR LEGEND

6 Black

7 White

9 Special

STARTING SERIAL NUMBERS

		Detroit Built	St. Louis Built	Newark Built	Los Angeles Built
TP1-L	(Savoy	2131-100001	2137-100001	2136-100001	2135-100001
TP1-L	(Savoy Sub.)	2531-100001	2537-100001	2536-100001	2535-100001
TP1-M	(Belvedere)	2231-100001	2237-100001	2236-100001	2235-100001
TP1-M	(Belvedere Sub.)	2631-100001	2637-100001	2636-100001	2635-100001
TP1-H	(Fury)	2331-100001	2337-100001	2336-100001	2335-100001
TP2-L	(Savoy)	3131-100001	3137-100001	3136-100001	3135-100001
TP2-L	(Savoy Sub.)	3531-100001	3537-100001	3536-100001	3535-100001
TP2-M	(Belvedere)	3231-100001	3237-100001	3236-100001	3235-100001
TP2-M	(Belvedere Sub.)	3631-100001	3637-100001	3636-100001	3635-100001
TP2-H	(Fury)	3331-100001	3337-100001	3336-100001	3335-100001
TP2-H	(Fury Sub.)	3731-100001	3737-100001	3736-100001	3735-100001
TP2-P	(Fury Sport)	3431-100001	3437-100001	3436-100001	3435-100001

TRIM CODE	MODEL	MATERIAL			COLOR	SED.	SP. 4D.	SUB.	SP. CL. CP.	CV. CP.
		Cloth	Vinyl	Leather						
301	P1-L, P2-L	*	*	-	Blue	*	-	-	-	-
303	P1-L, P2-L	*	*	-	Tan	*	-	-	-	-
306	P1-L, P2-L	*	*	-	Alabaster & Black	*	-	-	-	-
394	P1-L, P2-L	*	*	-	Gray	*	-	-	-	-
401	P1-L, P2-L	-	*	-	Blue	-	-	*	-	-
403	P1-L, P2-L	-	*	-	Tan	-	-	*	-	-
406	P1-L, P2-L	-	*	-	Alabaster & Black	-	-	*	-	-
411	P1-L, P2-L	-	*	-	Blue	*	-	-	-	-
413	P1-L, P2-L	-	*	-	Tan	*	-	-	-	-
494	P1-L, P2-L	-	*	-	Gray	*	-	-	-	-
321	P1-M, P2-M	*	*	-	Blue	*	-	-	*	-
322	P1-M, P2-M	*	*	-	Green	*	-	-	*	-
323	P1-M, P2-M	*	*	-	Tan	*	-	-	*	-
325	P1-M, P2-M	*	*	-	Alabaster & Black	*	-	-	*	-
326	P1-M, P2-M	*	*	-	Red	*	-	-	*	-
421	P1-M, P2-M	-	*	-	Blue	-	-	*	-	-
423	P1-M, P2-M	-	*	-	Alabaster & Black	-	-	*	-	-
425	P1-M, P2-M	-	*	-	Red	-	-	*	-	-
426	P1-M, P2-M	-	*	-	Alabaster & Black	-	-	*	-	-
431	P1-M, P2-M	-	*	-	Blue	*	-	-	-	-
433	P1-M, P2-M	-	*	-	Tan	*	-	-	-	-
341	P1-H, P2-H	*	*	-	Blue	*	*	-	*	-
342	P1-H, P2-H	*	*	-	Green	*	*	-	*	-
343	P1-H, P2-H	*	*	-	Tan	*	*	-	*	-
345	P1-H, P2-H	*	*	-	Red	*	*	-	*	-
346	P1-H, P2-H	*	*	-	Alabaster & Black	*	*	-	*	-
441	P1-H, P2-H	-	*	-	Blue	*	*	-	*	-
442	P1-H, P2-H	-	*	-	Green	-	-	*	-	-
443	P1-H, P2-H	-	*	-	Tan	*	*	-	*	-
445	P1-H, P2-H	-	*	-	Red	*	*	-	*	-
446	P1-H, P2-H	-	*	-	Alabaster & Black	-	-	-	-	*
447	P1-H, P2-H	-	*	-	Alabaster & Black	-	-	*	-	-
451	P1-P, P2-P	-	*	-	Blue	-	-	-	*	*
455	P1-P, P2-P	-	*	-	Red	-	-	-	*	*
459	P1-P, P2-P	-	*	-	Copper & Black	-	-	-	*	*

★ Indicates use as required.

⊠ Indicates parts not listed in any previous parts book.
September 4, 1962.

Printed in U.S.A.

Prices and specifications subject to change without notice.
Right and left part numbers are on same line,
first number is right, second number is left.

CODE	REMARKS	PER CAR	SED.	SP. 4 D.	SUB.	SP. CL. CP.	CV. CP.
NOTE: RIGHT HAND AND LEFT HAND PARTS LISTED ON THE SAME LINE. Whenever right and left hand parts are identified by consecutive part numbers they will be listed as in the following example: PANEL, Door Trim 2083 344-5 Interpreted, this indicates that Panel, right is Part No. 2083 344 and Panel, left is Part No. 2083 345.							
23-71-1	COVER, Front Console P2-P (code 451) (code 455) (code 459)	1 1 1	----	----	----	E2431 970-1 E2431 974-5 E2431 976-7	E2431 970-1 E2431 974-5 E2431 976-7
23-76-3	ARM REST, Front Door P1, P2 (codes 301, 321, 401, 411, 421, 431)(small) (blue) (codes 306, 326, 406, 426) (alabaster) (codes 341, 441, 451)(large) (blue) (codes 343, 443)(large) (tan) (code 342) (green)	2 1 1 1 1	2413 934 2413 940 2428 970-1 2428 974-5 2428 972-3	----	2413 934 2413 940 2428 970-1 2428 974-5 2428 972-3	2413 934 2413 940 2428 970-1 2428 974-5 2428 972-3	2428 970-1 2428 974-5
	(codes 325, 425)(small) (red) (codes 345, 445, 455) (large) (red) (codes 346, 446, 447) (large) (alabaster)	2 1 1	2413 938 2428 976-7 2428 978-9	----	2413 938 2428 976-7 2428 978-9	2413 938 2428 976-7 2428 978-9	2428 976-7 2428 978-9
	(code 459) (black) (codes 394, 494, 499) (gray) (codes 342, 442) (large) (green) Screw (code 322)(small) (green) (codes 303, 323, 403, 413, 423, 433)(small) (tan)	1 2 1 4 2 2	----	----	----	2428 982-3 2413 944 2428 972-3 162 090 2413 935 2413 936	2428 982-3 162 090
23-76-16	NUT, Arm Rest to Panel P1, P2	4	1280 134	1280 134	1280 134	1280 134	1280 134
23-76-18	ARM REST, Front Seat Back Center P1, P2 (codes 341, 441) (codes 342, 442) (codes 343, 443) (codes 345, 445) (codes 346, 446, 447)	1 1 1 1 1	2414 359 2414 360 2414 361 2414 362 2414 363	2414 359 2414 360 2414 361 2414 362 2414 363	2414 359 2414 360 2414 361 2414 362 2414 363	2414 359 2414 360 2414 361 2414 362 2414 363	2414 359 2414 361 2414 362 2414 363
23-76-27	HOOK, Front Seat Arm Rest Frame Retainer P1-H, P2-H	1	1918 568	1918 568	1918 568	1918 568	1918 568
23-76-28	BAR, Front Seat Center Arm Rest Frame Lock	1	2270 102	2270 102	2270 102	2270 102	2270 102
23-76-34	COVER, Front Seat Back Center Arm Rest P1, P2 (codes 341, 441) (codes 342, 442) (codes 343, 443) (codes 345, 445) (codes 346, 446, 447)	1 1 1 1 1	2414 354 2414 355 2414 356 2414 357 2414 358	2414 354 2414 355 2414 356 2414 357 2414 358	2414 354 2414 355 2414 356 2414 357 2414 358	2414 354 2414 355 2414 356 2414 357 2414 358	2414 354 2414 355 2414 356 2414 357 2414 358

★ Indicates use as required.
 E Indicates parts not listed in any previous parts book.
 Right and left part numbers are on same line,
 first number is right, second number is left.
 * Indicates change or addition.

1963 PASSENGER CAR PARTS CATALOG

INTERIOR TRIM

CODE	REMARKS	PER CAR	SED.	SP. 4 D.	SUB.	SP. CL. CP.	CV. CP.
23-76-59	ARM REST, Rear Door P1, P2 (codes 301, 321, 341, 401, 411, 421, 431, 441) (blue)	2	2413 934	2413 934	2413 934		
	(codes 303, 323, 343, 403, 413, 423, 433, 443) (tan)	2	2413 936	*2413 936	2413 936	2413 936	
	(codes 325, 345, 425, 445) (red)	2	2413 938	2413 938	2413 938		
	(codes 306, 326, 346, 406, 426, 447) (alabaster)	2	2413 940	----	2413 940		
	(codes 322, 342, 442) (green)	2	2413 935	2413 935	2413 935		
	(code 494) (gray)	2	2413 944				
	(door arm rest to door nut)	4	1280 134	1280 134	1280 134		
23-76-66	ARM REST, Rear Quarter (codes 301, 321, 341, 441, 451) (blue)	2	2413 934	*2413 934	----	2413 934	
	(codes 303, 323, 343, 443) (tan)	2	2413 936	*2413 936	----	2413 936	
	(codes 322, 342) (green)	2	2413 935	----	----	2413 935	
	(codes 325, 345, 445, 455) (red)	2	2413 938	*2413 938			
	(code 459) (black)	2	----	----	----	2413 941	
	(code 494) (gray)	2	2413 944				
23-76-80	NUT, Quarter Arm Rest to Panel P1, P2	4	1280 134	----	----	1280 134	
23-77-3	STRAP, Assist P1, P2 (center pillar)	2	2274 841				
23-77-17	SPACER, Center Pillar Assist Strap to Garnish Moulding P1, P2	2	2292 201				
23-79-3	CARPET, Front Floor P1-M, P2-M, P1-H, P2-H, P2-P (blue)	1	2299 473	2299 473	2299 473	2299 473	2299 473
	(green)	1	2299 474	2299 474	2299 474	2299 474	
	(tan)	1	2299 475	2299 475	2299 475	2299 475	2299 475
	(red)	1	2299 476	2299 476	2299 476	2299 476	2299 476
	(black)	1	2299 477	2299 477	2299 477	2299 477	2299 477
	P2-M, P2-H, P2-P (use with floor mounted shift) (blue)	1	2448 239	2448 239	2448 239	2448 239	2448 239
	(green)	1	2448 240	2448 240	2448 240	2448 240	
	(tan)	1	2448 241	2448 241	2448 241	2448 241	2448 241
	(red)	1	2448 242	2448 242	2448 242	2448 242	2448 242
	(black)	1	2448 243	2448 243	2448 243	2448 243	2448 243
	23-79-33	CARPET, Rear Floor P1-M, P2-M, P1-H, P2-H, P2-P (blue)	1	2299 484	2299 484	2299 484	2299 484
(green)		1	2299 485	2299 485	2299 485	2299 485	
(tan)		1	2299 486	2299 486	2299 486	2299 486	2299 486
(red)		1	2299 487	2299 487	2299 487	2299 487	2299 487
(black)		1	2299 488	2299 488	2299 488	2299 488	2299 488
(front center floor pan cover panel insert) (vinoleum) (codes 341, 401, 421) (blue)		1	----	----	*2297 573		
(codes 342, 422, 442) (green)		1	----	----	2297 578		
(codes 343, 403, 423) (tan)		1	----	----	2297 574		

★ Indicates use as required.

☐ Indicates parts not listed in any previous parts book.

Jan. 3, 1964 Supersedes Dec. 14, 1962.

Prices and specifications subject to change without notice.

Right and left part numbers are on same line,
first number is right, second number is left.

* Indicates change or addition.

Printed in U.S.A.

CODE	REMARKS	PER CAR	SED.	SP. 4 D.	SUB.	SP. CL. CP.	CV. CP.	
23-79-33	CARPET, Rear Floor - Cont'd P1-M, P2-M, P1-H, P2-H, P2-P (codes 344, 425 (red) (codes 346, 406, 426, 447) (black) (rear floor pan insert) (vinoleum) (codes 401, 421) (blue) (code 442) (green) (codes 403, 423, 443) (codes 425, 445) (tan) (codes 425, 445) (red) (codes 406, 426, 447) (black)	1 1 1 1 1 1 1 1	----- ----- ----- ----- ----- ----- ----- -----	----- ----- ----- ----- ----- ----- ----- -----	----- ----- ----- ----- ----- ----- ----- -----	E1800 TR6 2297 576 2297 579 2297 584 2297 580 E1801 TR6 2297 582		
	(rear floor pan cover insert) (vinoleum) (codes 401, 421, 441) (blue) (codes 403, 423, 443) (tan) (codes 425, 445) (red) (codes 406, 426, 447) (black) (code 442) (green) (floor pan axle kick-up front trim panel)(paint as required)	1 1 1 1 1 1 1	----- ----- ----- ----- ----- ----- -----	----- ----- ----- ----- ----- ----- -----	----- ----- ----- ----- ----- ----- -----	2297 585 2297 586 E1802 TR6 2297 588 2297 590 2413 413		
23-79-79	COVER, Tailgate Inside Panel P1, P2 (vinoleum) (codes 401, 421, 441) (blue) (codes 403, 423, 443) (tan) (codes 406, 426, 447) (black) (codes 425, 445) (red) (code 442) (green)	1 1 1 1 1 1	----- ----- ----- ----- ----- -----	----- ----- ----- ----- ----- -----	----- ----- ----- ----- ----- -----	2297 555 2297 556 2297 558 E1803 TR6 2297 560		
	(access hole cover) (codes 341, 401, 421) (blue) (codes 343, 403, 423) (tan) (codes 345, 425) (red) (codes 346, 406, 426) (black) (code 342) (green)	1 1 1 1 1	----- ----- ----- ----- -----	----- ----- ----- ----- -----	----- ----- ----- ----- -----	2297 555 2297 556 E1803 TR6 2297 558 2297 560		
23-81-3	HANDLE, Rear Door Pull-To P1-L, P2-L	1	1697 413					
23-81-8	SPACER, Rear Door Pull-To Handle P1-L, P2-L	2	1964 579					
23-82-30	HOOK, Coat Hanger P1, P2 Screw	2 ★	2165 837 148 095	2165 837 148 095	2165 837 148 095	2165 837 148 095		
23-82-39	BRACKET, Coat Hook Support P1, P2	2	*2481 175	*2481 175	*2481 175	*2481 175		

★ Indicates use as required.
 E Indicates parts not listed in any previous parts book.
 Right and left part numbers are on same line,
 first number is right, second number is left.
 * Indicates change or addition.

Printed in U.S.A.
 Prices and specifications subject to change without notice.
 Jan. 3, 1964 Supersedes Sept. 4, 1962.

CODE	REMARKS	PER CAR	SED.	SP. 4 D.	SUB.	SP. CL. CP.	CV. CP.
23-84-3	PAD, Instrument Panel Trim P1, P2						
	(codes 301, 321, 341, 411, 421, 431, 441, 451) (blue)	1	2432 728	2432 728	2432 728	2432 728	2432 728
	(codes 303, 323, 343, 403, 413, 423, 433, 443) (tan)	1	2432 730	2432 730	2432 730	2432 730	2432 730
	(codes 306, 326, 346, 394, 406, 426, 446, 447, 459, 494) (black)	1	2432 732	2432 732	2432 732	2432 732	2432 732
	(codes 322, 342, 442) (green)	1	2432 729	2432 729	2432 729	2432 729	2432 729
	(codes 325, 345, 425, 445, 455) (red)	1	2432 731	2432 731	2432 731	2432 731	2432 731
	(attaching clip) (lower) (attaching clip)	2 ★	6008 193 6008 222	6008 193 6008 222	6008 193 6008 222	6008 193 6008 222	6008 193 6008 222
23-86-3	HEADLINING and LISTINGS P1-L, P2-L						
	(codes 301, 321, 341, 411, 441, 451)	1	2429 506	2429 506	----	2429 506	
	(codes 303, 306, 323, 325, 326, 343, 345, 346, 413, 443, 445, 455, 459)	1	2429 507	2429 507	----	2429 507	
	(codes 322, 342)	1	2429 509	*2409 509	----	2429 509	
	(codes 394, 494)	1	2429 508				
	P1, P2 (perf. hardboard)						
	(No. 1)	1	----	----	2273 461		
(No. 2)	1	----	----	2413 905			
(No. 3)	1	----	----	2273 463			
(No. 4)	1	----	----	2273 464			
(No. 5)	1	----	----	2273 465			
(No. 6)	1	----	----	2273 466			
(No. 7)	1	----	----	2273 467			
23-86-10	BOW, Roof Support P1, P2 (No. 1)	1	*2166 267	*2166 267	*2166 267	*2166 267	
	(No. 2)	1	2166 268	2166 268	2166 268	2166 268	
	(Nos. 3 and 4)	1	----	----	2166 269		
23-86-16	SUPPORT, Roof Inside Finish Panel on Roof Rail P1, P2	12	----	2216 461	----	2216 461	
	(fastener)	12	----	6000 922	----	6000 922	
23-86-19	STRIP, Headlining Retaining P1, P2						
	Rear	1	2255 430-1				
	Side Front	1	----	----	2251 806-7		
	Side Rear	1	----	----	2251 446-7		
	Rear	1	----	----	2251 448		
Corner Rear	1	----	----	2251 444-5			
23-86-24	RETAINER, Roof Inside Finish Moulding P1, P2 (No. 1)	1	----	----	*2292 162		
	(No. 2)	1	----	----	2292 163		
	(No. 3)	1	----	----	2292 164		
	(No. 4)	1	----	----	2292 165		
	(No. 5)	1	----	----	2292 166		
	(No. 6)	1	----	----	2292 167		
23-86-35	MOULDING, Roof Inside Finish Panel P1-M, P2-M						
	(No. 1)	1	----	----	2292 377	2292 373	
	(No. 2)	1	----	----	2292 377	2292 375	
	(No. 3)	1	----	----	2292 377	2292 377	
(No. 4 thru No. 6)	1	----	----	2292 377			

★ Indicates use as required.

☐ Indicates parts not listed in any previous parts book.

Jan. 3, 1964 Supersedes Sept. 4, 1962.

Page IT-32

Printed in U.S.A.

Prices and specifications subject to change without notice.

Right and left part numbers are on same line,

first number is right, second number is left.

* Indicates change or addition.

CODE	REMARKS	PER CAR	SED.	SP. 4 D.	SUB.	SP. CL. CP.	CV. CP.						
23-86-35	MOULDING, Roof Inside												
	Finish Panel - Cont'd												
	P1-H, P2-H, P2-P												
	(No. 1)	1	----	2292 372	⊖2440 144	2292 372							
	(No. 2)	1	----	2292 374	⊖2440 144	2292 374							
23-86-36	CAP, Roof Inside Finish Moulding	12	----	----									
								P1, P2	5	----	1759 635		
23-91-6	PANEL, Cowl Trim												
	P1, P2												
	(codes 301, 321, 341, 401, 411, 421, 431, 441, 451) (blue)	1	2413 000-1	2413 000-1	2413 000-1	2413 000-1	2413 000-1						
	451) (blue)	1	2413 000-1	2413 000-1	2413 000-1	2413 000-1	2413 000-1						
	(codes 303, 323, 343, 403, 413, 413, 423, 443) (tan)	1	2413 004-5	2413 004-5	2413 004-5	2413 004-5	2413 004-5						
	(codes 306, 406, 459, 494) (black)	1	2413 006-7	----	2413 006-7	2413 006-7	2413 006-7						
	(codes 325, 346, 426, 446) (alabaster)	1	2413 008-9	2413 008-9	2413 008-9	2413 008-9	2413 008-9						
	(codes 322, 342, 422) (green)	1	2413 002-3	2413 002-3	2413 002-3	2413 002-3	2413 002-3						
	(codes 325, 345, 425, 445, 455) (red)	1	2413 010-1	2413 010-1	2413 010-1	2413 010-1	2413 010-1						
	23-92-5	PANEL, Door Trim											
		P1-L, P2-L, (2 D.)											
(code 301)		1	2413 162-3										
(code 303)		1	2413 164-5										
(code 306)		1	2413 166-7										
(code 494)		1	2413 768-9										
(code 394)		1	2413 768-9										
P1-L, P2-L (4 D.)													
(codes 301, 401, 411) Front		1	2413 178-9	----	2413 178-9								
Rear		1	2413 184-5	----	2413 184-5								
23-92-5	(codes 303, 403, 413) Front	1	2413 180-1	----	2413 180-1								
	Rear	1	2413 186-7	----	2413 186-7								
	(codes 306, 406) Front	1	2413 182-3	----	2413 182-3								
	Rear	1	2413 188-9	----	2413 188-9								
	(code 494) Front	1	2413 762-3										
	Rear	1	2413 764-5										
	P1-M, P2-M (2 D.)												
	(code 321)	1	2413 328-9	----	----	2413 348-9							
(code 322)	1	2413 330-1											
(code 323)	1	2413 332-3			*2413 352-3								
(code 325)	1	2413 780-1	----	----	2413 774-5								
(code 326)	1	2413 334-5	----	----	*2413 354-5								
23-92-5	P1-M, P2-M (4 D.)												
	(codes 321, 421, 431) Front	1	2413 256-7	----	2413 256-7								
	Rear	1	2413 264-5	----	2413 264-5								
	(code 322) Front	1	2413 258-9										
	Rear	1	2413 266-7										
	(codes 323, 423, 433) Front	1	2413 260-1	----	2413 260-1								
	Rear	1	2413 268-9	----	2413 268-9								
	(codes 326, 426) Front	1	2413 262-3	----	2413 262-3								
	Rear	1	2413 270-1	----	2413 270-1								
	(codes 325, 425) Front	1	2413 786-7	----	2413 786-7								
	Rear	1	2413 788-9	----	2413 788-9								

★ Indicates use as required.

⊖ Indicates parts not listed in any previous parts book.

Right and left part numbers are on same line, first number is right, second number is left.

* Indicates change or addition.

Printed in U.S.A.

Prices and specifications subject to change without notice.

Jan. 3, 1964 Supersedes Sept. 4, 1962.

1963 PASSENGER CAR PARTS CATALOG

INTERIOR TRIM

CODE	REMARKS	PER CAR	SED.	SP. 4 D.	SUB.	SP. CL. CP.	CV. CP.
23-92-5	PANEL, Door Trim - Cont'd P1-H, P2-H (2 D.) (codes 341, 441) (code 342) (codes 343, 443) (codes 345, 445) (codes 346, 446)	1 1 1 1 1	---- ---- ---- ---- ----	---- ---- ---- ---- ----	---- ---- ---- ---- ----	2413 208-9 2413 210-1 2413 212-3 2413 214-5 2413 216-7	2413 208-9 2413 212-3 2413 214-5 2413 216-7
	P1-H, P2-H (4 D.) (codes 341, 441) Front Rear (codes 342, 442) Front Rear (codes 343, 443) Front Rear	1 1 1 1 1 1	2413 278-9 2413 288-9 2413 280-1 2413 290-1 2413 282-3 2413 292-3	2413 304-5 2413 314-5 2413 306-7 2413 316-7 2413 308-9 2413 318-9	2413 278-9 2413 288-9 2413 280-1 2413 290-1 2413 282-3 2413 292-3		
	(codes 345, 445) Front Rear (code 346) Front Rear (code 447) Front Rear	1 1 1 1 1 1	2413 284-5 2413 294-5 2413 286-7 2413 296-7 ---- ----	2413 310-1 2413 320-1 2413 312-3 2413 322-3 ---- ----	2413 284-5 2413 294-5 2413 950-1 2413 952-3		
	P2-P (code 451) (code 455) (code 459)	1 1 1	---- ---- ----	---- ---- ----	---- ---- ----	2413 842-3 2413 844-5 2413 846-7	2413 842-3 2413 844-5 2413 846-7
23-92-8	FASTENER, Quarter Trim Panel P1, P2	★	975 633	975 633	----	975 633	975 633
23-96-3	PANEL, Luggage Compartment Front Lining P1, P2 (side to quarter) (filler)	1 1	2162 831 2292 876-7	2162 831 ----	---- ----	2162 831 2292 876-7	
23-96-8	PANEL, Luggage Compartment Side Lining P1, P2 (gray) Wheelhouse and Lower Quarter Trim Cover (paint as required) P1, P2 (2 seat) Right Left (3 seat) Right Left (extension)	1 1 1 1 1 1 1	2432 720-1 ---- ---- ---- ---- ----	2432 720-1 ---- ---- ---- ---- ----	---- ---- ---- ---- ---- ---- 2432 636-7	2432 720-1 E2432 722-3	
23-96-10	PANEL, Luggage Compartment Lower Deck Opening P1-H, P2-H, P2-P (4 D.)	1	E2432 986-7	E2432 986-7	----	E2432 986-7	E2432 986-7
23-96-41	RETAINER, Wheelhouse and Lower Quarter Trim Cover (paint as required) P1, P2 Plastic	6	----	----	2273 453		
23-99-4	COVER, Center Pillar Trim P1, P2 (codes 341, 441) (code 342) (codes 343, 443) (codes 345, 445) (code 346)	1 1 1 1 1	---- ---- ---- ---- ----	2428 646-7 2428 648-9 2428 650-1 2428 652-3 2428 654-5			
23-99-9	RETAINER, Body Rear Lock Pillar Quarter Trim P1, P2	1	----	----	2162 508-9		

★ Indicates use as required.

E Indicates parts not listed in any previous parts book.

Jan. 3, 1964 Supersedes Jan. 25, 1963.

Printed in U.S.A.
Prices and specifications subject to change without notice.Right and left part numbers are on same line,
first number is right, second number is left.

* Indicates change or addition.

CODE	REMARKS	PER CAR	SED.	SP. 4 D.	SUB.	SP. CL. CP.	CV. CP.
23-101-3	PANEL, Rear Quarter Trim P1-L, P2-L (2 D.)						
	(code 301)	1	2413 168-9				
	(code 303)	1	2413 170-1				
	(code 306)	1	2413 172-3				
	(codes 394, 494)	1	2413 770-1				
	P1-M, P2-M (2 D.)						
	(code 321)	1	2413 336-7	----	----		2413 356-7
	(code 322)	1	2413 338-9				
	(code 323)	1	2413 340-1	----	----		2413 360-1
	(code 325)	1	2413 782-3	----	----		2413 776-7
	(code 326)	1	2413 342-3	----	----		2413 362-3
	P1, P2 (4 D.)						
	(codes 301, 321, 341, 411, 431, 441)	1	2429 768-9	2429 768-9			
	(upper)	1	2429 796-7	2429 796-7			
	(lower)						
	(codes 303, 323, 343, 413, 433, 443)	1	2429 772-3	2429 772-3			
(upper)	1	2429 800-1	2429 800-1				
(lower)							
(code 306)	1	2429 778-9					
(upper)	1	2429 806-7					
(lower)							
(codes 322, 342)	1	2429 770-1					
(upper)	1	2429 798-9					
(lower)							
(codes 326, 346)	1	2429 780-1					
(upper)	1	2429 808-9					
(lower)							
(codes 325, 345, 445)	1	2429 776-7					
(upper)	1	2429 804-5					
(lower)							
(codes 394, 494)	1	2429 774-5					
(upper)	1	2429 802-3					
(lower)							
P1-H, P2-H							
(codes 341, 441)	1	----	----	----		2413 218-9	2413 232-3
(code 342)	1	----	----	----		2413 220-1	
(codes 343, 443)	1	----	----	----		2413 222-3	2413 234-5
(codes 345, 445)	1	----	----	----		2413 224-5	2413 236-7
(code 346)	1	----	----	----		2413 226-7	2413 238-9
P2-P (2 D.)							
(code 451)	1	----	----	----		2413 848-9	2413 858-9
(code 455)	1	----	----	----		2413 850-1	2413 860-1
(code 459)	1	----	----	----		2413 852-3	2413 862
(attaching screw & washer) (2 D.)	★	6023 381	----	----		6023 381	6023 381
23-101-14	COVER, Upper Quarter Front Trim (paint as required) P1, P2	1	----	----	2297 504-5		
23-101-33	BRACKET, Quarter Trim Panel Support	2	----	----	----	----	E2490 484
23-102-3	PANEL, Shelf Trim P1, P2						
	(codes 301, 321, 341, 411, 431, 441, 451) (blue)	1	2413 994	2413 994	----	2413 994	
	(codes 322, 342) (green)	1	2413 995	2413 995	----	2413 995	
	(codes 303, 323, 343, 413, 433, 443) (tan)	1	2413 996	2413 996	----	2413 996	
	(codes 306, 326, 346, 459, 494) (black)	1	2413 998	2413 998	----	2413 998	
	(codes 325, 344, 445, 455) (fastener)	1	2413 997	2413 997	----	2413 997	
		★	6000 903	6000 903	----	6000 903	

★ Indicates use as required.

⊠ Indicates parts not listed in any previous parts book.
Right and left part numbers are on same line,
first number is right, second number is left.

* Indicates change or addition.

Printed in U.S.A.

Prices and specifications subject to change without notice.

1963 PASSENGER CAR PARTS CATALOG

INTERIOR TRIM

CODE	REMARKS	PER CAR	SED.	SP. 4 D.	SUB.	SP. CL. CP.	CV. CP.
23-103-3	PANEL, Visor Trim P1, P2 (codes 301, 321, 341, 411, 431, 441, 451) (blue) (codes 303, 306, 322, 323, 325, 326, 343, 345, 346, 413, 443, 445, 455, 459) (alabaster) (codes 322, 342) (green)	2 2 2	2413 812	2413 812	----	2413 812	
	(codes 401, 403, 406, 421, 423, 425, 426, 441, 442, 443, 445, 447) (white) (codes 441, 451) (blue) (code 443) (tan) (codes 445, 455) (red) (code 446) (alabaster) (code 459) (black) (code 494) (gray)	2 2 2 2 2 2 2	----	2273 286	2273 286	2273 286	2413 424 2413 425 2413 426 2413 427 2413 450
23-103-10	ARM and BRACKET, Visor P1, P2 (chrome)	1	2292 894-5	2292 894-5	2292 894-5	2292 894-5	2162 686-7
23-103-18	WASHER, Visor Arm Tension P1, P2	2	6000 106	6000 106	6000 106	6000 106	6000 106
23-103-48	SUPPORT, Visor Inner P1, P2 (3 1/8")	2	2162 628	2162 628	2162 628	2162 628	2162 628
23-108-4	CUSHION, Front Seat P1-L, P2-L (2 D.) (code 301) (w/airfoam pad) (w/heavy duty spring and airfoam pad)	1 1 1	2411 301 2411 304 2411 307				
	(code 303) (w/airfoam pad) (w/heavy duty spring and airfoam pad) (code 306) (w/airfoam pad) (w/heavy duty spring and airfoam pad) (code 394) (police)	1 1 1 1 1 1	2411 302 2411 305 2411 308 2411 303 2411 306 2411 309 2429 843				
	P1-L, P2-L (4 D.) (code 301) (w/airfoam pad) (w/heavy duty and airfoam pad)	1 1 1	2411 232 2411 238 2411 235				
	(code 303) (w/airfoam pad) (w/heavy duty spring and airfoam pad) (code 306) (w/airfoam pad) (w/heavy duty spring and airfoam pad) (code 394) (police)	1 1 1 1 1 1	2411 233 2411 239 2411 236 2411 234 2411 240 2411 237 2429 830				

★ Indicates use as required.

☐ Indicates parts not listed in any previous parts book.

Jan. 3, 1964 Supersedes Dec. 14, 1962.

Printed in U.S.A.

Prices and specifications subject to change without notice.

Right and left part numbers are on same line,
first number is right, second number is left.

* Indicates change or addition.

CODE	REMARKS	PER CAR	SED.	SP. 4D.	SUB.	SP. CL. CP.	CV. CP.
23-108-4	CUSHION, Front Seat - Cont'd						
	P1-M, P2-M (2D.) (plain design) (code 321)	1	⊕2429 955	---	---	⊕2429 955	
	(w/heavy duty spring and airfoam pad)	1	⊕2429 960	---	---	⊕2429 960	
	(code 322)	1	⊕2429 956	---	---		
	(w/heavy duty spring and airfoam pad)	1	⊕2429 961	---	---	⊕2429 957	
	(code 323)	1	⊕2429 957	---	---		
	(w/heavy duty spring and airfoam pad)	1	⊕2429 962	---	---	⊕2429 962	
	(code 326)	1	⊕2429 958	---	---	⊕2429 958	
	(w/heavy duty spring and airfoam pad)	1	⊕2429 963	---	---	⊕2429 963	
	(code 325)	1	⊕2429 959	---	---	⊕2429 959	
	(w/heavy duty spring)	1	⊕2429 964	---	---	⊕2429 964	
	(code 394)	1	2429 843				
	P1-M, P2-M (2 D.) (stitched design) (code 321)	1	⊕2433 798	---	---	⊕2433 798	
	(w/heavy duty spring and airfoam pad)	1	⊕2433 803	---	---	⊕2433 803	
	(code 322)	1	⊕2433 799	---	---	⊕2433 799	
	(w/heavy duty spring and airfoam pad)	1	⊕2433 804	---	---	⊕2433 800	
	(code 323)	1	⊕2433 800	---	---		
	(w/heavy duty spring and airfoam pad)	1	⊕2433 805	---	---	⊕2433 805	
	(code 325)	1	⊕2433 801	---	---	⊕2433 801	
	(w/heavy duty spring and airfoam pad)	1	⊕2433 806	---	---	⊕2433 806	
	(code 326)	1	⊕2433 802	---	---	⊕2433 802	
	(w/heavy duty spring and airfoam pad)	1	⊕2433 807	---	---	⊕2433 807	
	P1-M, P2-M (4 D.) (plain design) (codes 321, 421)	1	*2411 447	---	*2411 579		
	(w/heavy duty spring and airfoam pad)	1	2411 451	---	2411 583		
	(code 322)	1	2411 448	---			
	(w/heavy duty spring and airfoam pad)	1	2411 452	---			
	(codes 323, 423)	1	2411 449	---	2411 581		
	(w/heavy duty spring and airfoam pad)	1	2411 453	---	2411 585		
	(codes 325, 425)	1	⊕2429 281	---	*2429 291	⊕2414 777	
	(w/heavy duty spring and airfoam pad)	1	⊕2429 282	---	2429 292	⊕2414 815	⊕2414 815
	(codes 326, 426)	1	2411 450	---	2411 582		
	(w/heavy duty spring and airfoam pad)	1	2411 454	---	2411 586		
	(code 325)	1	2429 281	---	---	2414 777	
	P1-M, P2-M (stitched design) (codes 321, 421)	1	⊕2433 673	---	⊕2433 870		
	(w/heavy duty spring and airfoam pad)	1	⊕2433 688	---	⊕2433 874		
	(code 322)	1	⊕2433 674	---			
	(w/heavy duty spring and airfoam pad)	1	⊕2433 689	---	⊕2433 871		
	(codes 323, 423)	1	⊕2433 675	---			
	(w/heavy duty spring and airfoam pad)	1	⊕2433 690	---	⊕2433 875		
	(codes 325, 425)	1	⊕2433 676	---	⊕2433 872		
	(w/heavy duty spring and airfoam pad)	1	⊕2433 691	---	⊕2433 876		

★ Indicates use as required.
 ⊕ Indicates parts not listed in any previous parts book.
 Right and left part numbers are on same line,
 first number is right, second number is left.
 * Indicates change or addition.

1963 PASSENGER CAR PARTS CATALOG

INTERIOR TRIM

CODE	REMARKS	PER CAR	SED.	SP. 4 D.	SUB.	SP. CL. CP.	CV. CP.
23-108-4	CUSHION, Front Seat - Cont'd						
	P1-M, P2-M (stitched design)	1	⊕2433 677	----	⊕2433 873		
	(codes 326, 426)						
	(w/heavy duty spring and airfoam pad)	1	⊕2433 692	----	⊕2433 877		
	P1, P2 (4 D.)						
	(code 401)	1	----	----	2411 358		
	(w/airfoam pad)	1	----	----	2411 361		
	(w/heavy duty spring and airfoam pad)	1	----	----	2411 364		
	(code 403)	1	----	----	2411 359		
	(w/airfoam pad)	1	----	----	2411 362		
	(w/heavy duty spring and airfoam pad)	1	----	----	2411 365		
	(code 406)	1	----	----	2411 360		
	(w/airfoam pad)	1	----	----	2411 363		
	(w/heavy duty spring and airfoam pad)	1	----	----	2411 366		
	P1-M, P2-M						
	(code 341)	1	2414 319	2414 319	----	2429 250	
	(6 way elec.)	1	2414 324	2414 324	----	2429 255	
	(code 342)	1	2414 320	2414 320	----	2429 251	
	(6 way elec.)	1	2414 325	2414 325	----	2429 256	
	(code 343)	1	2414 321	2414 321	----	2429 252	
	(6 way elec.)	1	2414 326	2414 326	----	2429 257	
	(code 345)	1	2414 322	2414 322	----	2429 253	
	(6 way elec.)	1	2414 327	2414 327	----	2429 258	
	(code 346)	1	2414 323	2414 323	----	2429 254	
	(6 way elec.)	1	2414 328	2414 328	----	2429 259	
	P1-L, P2-L						
	(code 411)	1	2414 800				
	(w/airfoam pad)	1	2414 775				
	(code 413)	1	2414 801				
	(w/airfoam pad)	1	2414 776				
	(code 494) (fleet)	1	2293 636				
	(w/airfoam pad)	1	2293 826				
	(w/heavy duty spring and airfoam pad)(fleet, taxi and police)	1	2293 637				
	P1-H, P2-H						
	(code 441)	1	2429 260	2429 260	2429 260	2414 538	2414 538
	(6 way elec.)	1	2429 263	2429 263	2429 263	2414 542	2414 542
	(code 442)	1	----	----	2429 532		
	(6 way elec.)	1	----	----	2429 534		
	(code 443)	1	2429 261	2429 261	2429 261	2414 539	2414 539
	(6 way elec.)	1	2429 264	2429 264	2429 264	2414 543	2414 543
	(code 445)	1	2429 262	2429 262	2429 262	2414 540	2414 540
	(6 way elec.)	1	2429 265	2429 265	2429 265	2414 544	2414 544
	(code 446)	1	----	----	----	----	2414 541
	(6 way elec.)	1	----	----	----	----	2414 545
	(code 447)	1	----	----	2429 533		
	(6 way elec.)	1	----	----	2429 535		
	P2-P						
	(code 451)	1	----	----	----	2429 130-1	2429 130-1
	(code 455)	1	----	----	----	2429 132-3	2429 132-3
	(code 459)	1	----	----	----	2429 134-5	2429 134-5
	P1-M, P2-M						
	(code 431)	1	2414 775				
	(code 433)	1	2414 776				

★ Indicates use as required.

⊕ Indicates parts not listed in any previous parts book.

Jan. 3, 1964 Supersedes Dec. 14, 1962.

Page IT-38

Printed in U.S.A.

Prices and specifications subject to change without notice.

Right and left part numbers are on same line, first number is right, second number is left.

* Indicates change or addition.

CODE	REMARKS	PER CAR	SED.	SP. 4 D.	SUB.	SP. CL. CP.	CV. CP.
23-108-5	COVER, Front Seat Cushion P1-L, P2-L (2 D.)						
	(code 301)	1	2411 298				
	(code 303)	1	2411 299				
	(code 306)	1	2411 300				
	(code 394) (police)	1	2429 842				
	P1-L, P2-L (4 D.)						
	(code 301)	1	2411 229				
	(code 303)	1	2411 230				
	(code 306)	1	2411 231				
	(code 394)	1	2429 829				
	(code 401)	1	----	----		2411 355	
	(code 403)	1	----	----		2411 356	
	(code 406)	1	----	----		2411 357	
	(code 411)	1	2414 773				
	(code 413)	1	2414 774				
	(code 494) (fleet, taxi and police)	1	2293 635				
	P1-M, P2-M (2 D.) (plain design)						
	(code 321)	1	*2411 515	----	----	*2411 515	
	(code 322)	1	2411 516	----	----	2411 516	
	(code 323)	1	2411 517	----	----	2411 517	
	(code 325)	1	2414 617	----	----	2414 617	
	(code 326)	1	2411 518	----	----	2411 518	
	P1-M, P2-M (2 D.) (stitched design)						
	(code 321)	1	B2433 783	----	----	B2433 783	
	(code 322)	1	B2433 784	----	----	B2433 784	
	(code 323)	1	B2433 785	----	----	B2433 785	
	(code 325)	1	B2433 786	----	----	B2433 786	
	(code 326)	1	B2433 787	----	----	B2433 787	
	P1-M, P2-M (4 D.) (plain design)						
	(code 321)	1	*2411 439				
	(code 322)	1	2411 440				
	(code 323)	1	2411 441				
	(code 325)	1	2429 280				
	(code 326)	1	2411 442				
	(code 421)	1	----	----		2411 571	
	(code 423)	1	----	----		2411 573	
	(code 425)	1	----	----		2429 290	
	(code 426)	1	----	----		2411 574	
	P1-M, P2-M (4 D.) (stitched design)						
	(code 321)	1	B2433 668				
	(code 322)	1	B2433 669				
	(code 323)	1	B2433 670				
	(code 325)	1	B2433 671				
	(code 326)	1	B2433 672				
	(code 421)	1	----	----		B2433 858	
	(code 423)	1	----	----		B2433 859	
	(code 425)	1	----	----		B2433 860	
	(code 426)	1	----	----		B2433 861	
	P1-M, P2-M						
	(code 431)	1	2414 773				
	(code 433)	1	2414 774				
	P1-H, P2-H						
	(code 341)	1	2414 314	2414 314	----	2414 314	
	(code 342)	1	2414 315	2414 315	----	2414 315	
	(code 343)	1	2414 316	2414 316	----	2414 316	

★ Indicates use as required.
 □ Indicates parts not listed in any previous parts book.
 Right and left part numbers are on same line, first number is right, second number is left.
 * Indicates change or addition.

1963 PASSENGER CAR PARTS CATALOG

INTERIOR TRIM

CODE	REMARKS	PER CAR	SED.	SP. 4 D.	SUB.	SP. CL. CP.	CV. CP.
23-108-5	COVER, Front Seat Cushion - Cont'd P1-H, P2-H						
	(code 345)	1	2414 317	2414 317	----	2414 317	
	(code 346)	1	2414 318	2414 318	----	2414 318	
	(code 441)	1	2414 510	2414 510	2414 510	2414 510	2414 510
	(code 442)	1	-----	-----	2429 541		
	(code 443)	1	2414 511	2414 511	2414 511	2414 511	2414 511
	(code 445)	1	2414 512	2414 512	2414 512	2414 512	2414 512
	(code 446)	1	-----	-----	-----	-----	2414 513
	(code 447)	1	-----	-----	2429 687		
	P2-P						
	(code 451)	1	-----	-----	-----	2429 121	2429 121
	(code 455)	1	-----	-----	-----	2429 122	2429 122
	(code 459)	1	-----	-----	-----	2429 123	2429 123
23-108-12	BACK, Front Seat P1-L, P2-L (2 D.)						
	(code 301)	1	*2411 322-3				
	(w/ash receiver) Right	1	2411 334				
	(w/airfoam pad and heavy duty spring)	1	2411 328-9				
	(heavy duty springs, less airfoam)	1	2414 936				
	(code 303)	1	2411 324-5				
	(w/ash receiver) Right	1	2411 335				
	(w/airfoam pad and heavy duty spring)	1	2411 330-1				
	(heavy duty springs, less airfoam)	1	2414 937				
	(code 306)	1	2411 326-7				
	(w/ash receiver) Right	1	2411 336				
	(w/airfoam pad and heavy duty spring)	1	2411 332-3				
	(heavy duty springs, less airfoam)	1	2414 938				
	P1-L, P2-L (4 D.)						
	(codes 301, 401)	1	2411 247	-----	2411 370		
	(w/ash receiver)	1	2411 250	-----	2411 373		
	(w/heavy duty spring and airfoam pad)	1	2411 253	-----	2411 376		
	(codes 303, 403)	1	2411 248	-----	2411 371		
	(w/ash receiver)	1	2411 251	-----	2411 374		
	(w/heavy duty spring and airfoam pad)	1	2411 254	-----	2411 377		
	(code 306, 406)	1	2411 249	-----	2411 372		
	(w/ash receiver)	1	2411 252	-----	2411 375		
	(w/heavy duty spring and airfoam pad)	1	2411 255	-----	2411 378		
	P1-M, P2-M (2D.) (plain design)						
	(code 321)	1	*2411 547-8	-----	-----	*2411 547-8	
	(w/airfoam pad and heavy duty spring)	1	2411 555-6	-----	-----	2411 555-6	
	(code 322)	1	2411 549-50	-----	-----	2411 549-50	
	(w/airfoam pad and heavy duty spring)	1	2411 557-8	-----	-----	2411 557-8	
	(code 323)	1	2411 551-2	-----	-----	2411 551-2	
	(w/airfoam pad and heavy duty spring)	1	2411 559-60	-----	-----	2411 559-60	
	(code 325)	1	2429 184-5	-----	-----	2429 184-5	
	(code 326)	1	2411 553-4	-----	-----	2411 553-4	
	(w/airfoam pad and heavy duty spring)	1	2411 561-2	-----	-----	2411 561-2	
	(w/heavy duty spring)	1	2429 186-7	-----	-----	2429 186-7	

★ Indicates use as required.

☐ Indicates parts not listed in any previous parts book.
Jan. 3, 1964 Supersedes Sept. 4, 1962.

* Indicates change or addition.

CODE	REMARKS	PER CAR	SED.	SP. 4 D.	SUB.	SP. CL. CP.	CV. CP.
23-108-12	BACK, Front Seat - Cont'd P1-M, P2-M (2 D.) (stitched design)						
	(code 321) (w/airfoam pad and heavy duty spring)	1	E2433 828-9	----	----	E2433 828-9	
	(code 322) (w/airfoam pad and heavy duty spring)	1	E2433 838-9	----	----	E2433 838-9	
	(code 323) (w/airfoam pad and heavy duty spring)	1	E2433 830-1	----	----		
	(code 325) (w/airfoam pad and heavy duty spring)	1	E2433 840-1	----	----		
	(code 326) (w/airfoam pad and heavy duty spring)	1	E2433 832-3	----	----		
	(code 326) (w/airfoam pad and heavy duty spring)	1	E2433 842	----	----	E2433 842	
	(code 326) (w/airfoam pad and heavy duty spring)	1	E2433 834-5	----	----	E2433 834-5	
	(code 326) (w/airfoam pad and heavy duty spring)	1	E2433 844-5	----	----	E2433 844-5	
	(code 326) (w/airfoam pad and heavy duty spring)	1	E2433 836-7	----	----	E2433 836-7	
	(code 394) (ash receiver and standard spring)	1	E2433 846-7	----	----	E2433 846-7	
	(code 394) (ash receiver and standard spring)	1	2429 848-9	----	----		
	(code 394) (ash receiver and standard spring)	1	2429 850	----	----		
	P1-M, P2-M (4D.) (plain design)						
	(codes 321, 421) (w/airfoam pad and heavy duty spring)	1	*2411 463	----	*2411 595		
	(code 322) (w/airfoam pad and heavy duty spring)	1	2411 467	----	2411 599		
	(code 322) (w/airfoam pad and heavy duty spring)	1	2411 464	----			
	(codes 323, 423) (w/airfoam pad and heavy duty spring)	1	2411 468	----	2411 597		
	(code 325) (w/heavy duty spring)	1	2411 465	----	2411 601		
	(code 326) (w/airfoam pad and heavy duty spring)	1	2411 469	----	2411 602		
	(code 425) (w/heavy duty spring)	1	2429 284	----	2429 294		
	(code 425) (w/heavy duty spring)	1	2411 466	----	2429 295		
	(code 425) (w/heavy duty spring)	1	2411 470	----			
	(code 425) (w/heavy duty spring)	1	----	----			
	(code 425) (w/heavy duty spring)	1	----	----			
	(code 425) (w/heavy duty spring)	1	----	----			
	P1-M, P2-M (stitched design)						
	(codes 321, 421) (w/airfoam pad and heavy duty spring)	1	E2433 708	----	E2433 890		
	(code 322) (w/airfoam pad and heavy duty spring)	1	E2433 713	----	E2433 894		
	(code 322) (w/airfoam pad and heavy duty spring)	1	E2433 709	----	E2433 891		
	(codes 323, 423) (w/airfoam pad and heavy duty spring)	1	E2433 714	----			
	(codes 323, 423) (w/airfoam pad and heavy duty spring)	1	E2433 710	----	E2433 895		
	(codes 325, 425) (w/heavy duty spring and airfoam pad)	1	E2433 715	----	E2433 895		
	(codes 326, 426) (w/heavy duty spring and airfoam pad)	1	E2433 711	----	E2433 892		
	(codes 326, 426) (w/heavy duty spring and airfoam pad)	1	E2433 716	----	E2433 896		
	(codes 326, 426) (w/heavy duty spring and airfoam pad)	1	E2433 712	----	E2433 893		
	(codes 326, 426) (w/heavy duty spring and airfoam pad)	1	E2433 717	----	E2433 897		
	P1-L, P2-L (plain design)						
	(code 411)	1	*2414 784				
	(code 413)	1	2414 785				
	(code 394)	1	2429 833				
	P1-M, P2-M (plain design)						
	(code 431)	1	*2414 784				
	(code 433)	1	2414 785				

★ Indicates use as required.

E Indicates parts not listed in any previous parts book.

Right and left part numbers are on same line,

first number is right, second number is left.

* Indicates change or addition.

Printed in U.S.A.

Prices and specifications subject to change without notice.

Jan. 3, 1964 Supersedes Sept. 4, 1962.

1963 PASSENGER CAR PARTS CATALOG

INTERIOR TRIM

CODE	REMARKS	PER CAR	SED.	SP. 4 D.	SUB.	SP. CL. CP.	CV. CP.
23-108-12	BACK, Front Seat - Cont'd P1, P2 (stitched design) (codes 411, 431) (codes 413, 433) (code 494) (2 D.) (w/ash receiver) Rt. (w/heavy duty spring and airfoam pad)	1 1 1 1 1	⊕2433 976 ⊕2433 977 ⊕2429 898-9 ⊕2429 900 ⊕2429 901-2				
	P1-H, P2-H (4 D.) (code 341) (code 342) (code 343) (code 345) (code 346)	1 1 1 1 1	2414 344-5 2414 346-7 2414 348-9 2414 350-1 2414 352-3	2414 344-5 2414 346-7 2414 348-9 2414 350-1 2414 352-3	---- ---- ---- ---- ----	2429 240-1 2429 242-3 2429 244-5 2429 246-7 2429 248-9	
	P1-H, P2-H (code 441) (code 442) (code 443) (code 445) (code 446) (code 447)	1 1 1 1 1 1	2429 266-7 ---- 2429 268-9 2429 270-1 ---- ----	2429 266-7 ---- 2429 268-9 2429 270-1 ---- ----	2429 266-7 2429 528-9 2429 268-9 2429 270-1 ---- 2429 530-1	2414 574-5 ---- 2414 576-7 2414 578-9 ---- ----	2414 574-5 ---- 2414 576-7 2414 578-9 2414 580-1 ----
	P1-L, P2-L (code 494)(police) (heavy duty spring and airfoam pad) (w/ash receiver and standard spring) (back to cushion wedge spring adjusting screw)	1 1 1 2	2415 141 2415 143 2415 142 ----	---- ---- ---- ----	---- ---- ---- ----	6016 005 ---- ---- ----	6016 005 ---- ---- ----
23-108-15	SPRING and COVER, Front Seat P2-P (code 451) (code 455) (code 459)	1 1 1	---- ---- ----	---- ---- ----	---- ---- ----	2429 148 2429 149 2429 150	2429 148 2429 149 2429 150
23-108-16	COVER, Front Seat Back P1, P2 (2 D.) (code 301) (code 303) (code 306) P1, P2 (plain design) (code 321) (code 322) (code 323) (code 325) (code 326) P1, P2 (2 D.)(stitched design) (code 321) (code 322) (code 323) (code 325) (code 326) P1, P2 (code 341) (code 342) (code 343) (code 345) (code 346) (code 394)	1 1 1 1 1 1 1 1 1 1 1 1 1 1 1 1 1 1 1	2411 310-1 2411 312-3 2411 314-5 *2411 531-2 2411 533-4 2411 535-6 2429 182-3 2411 537-8 ⊕2433 808-9 ⊕2433 810-1 ⊕2433 812-3 ⊕2433 814-5 ⊕2433 816-7 ---- ---- ---- ---- ---- 2429 846-7	---- ---- ---- ---- ---- ---- ---- ---- ---- ---- ---- ---- ---- ---- ---- ---- ---- ----	---- ---- ---- ---- ---- ---- ---- ---- ---- ---- ---- ---- ---- ---- ---- ---- ---- ----	2411 531-2 2411 535-6 2429 182-3 2411 537-8 ⊕2433 808-9 ⊕2433 812-3 ⊕2433 814-5 ⊕2433 816-7 *2414 334-5 2414 336-7 2414 338-9 2414 340-1 2414 342-3	

★ Indicates use as required.

⊕ Indicates parts not listed in any previous parts book.

Jan. 3, 1964 Supersedes Jan. 25, 1963.

Printed in U.S.A.

Prices and specifications subject to change without notice.

Right and left part numbers are on same line,

first number is right, second number is left.

* Indicates change or addition.

CODE	REMARKS	PER CAR	SED.	SP. 4 D.	SUB.	SP. CL. CP.	CV. CP.	
23-108-16	COVER, Front Seat Back - Cont'd P1, P2 (4 D.) (plain design)							
	(codes 301, 401)	1	*2411 241	----	*2411 367			
	(codes 303, 403)	1	2411 242	----	2411 368			
	(codes 306, 406)	1	2411 243	----	2411 369			
	(codes 321, 421)	1	2411 455	----	2411 587			
	(code 322)	1	2411 456					
	(codes 323, 423)	1	2411 457	----	2411 589			
	(code 325)	1	2429 283					
	(codes 326, 426)	1	2411 458	----	⊠2411 590			
	P1, P2 (4 D.) (stitched design)							
	(codes 321, 421)	1	⊠2433 693	----	⊠2433 878			
	(code 322)	1	⊠2433 694					
	(codes 323, 423)	1	⊠2433 695	----	⊠2433 879			
	(codes 325, 425)	1	⊠2433 696	----	⊠2433 880			
(codes 326, 426)	1	⊠2433 697	----	⊠2433 881				
P1, P2 (code 341)	(codes 342, 442)	1	*2414 334-5	*2414 334-5				
	(code 343)	1	2414 336-7	2414 336-7	2429 522-3			
	(code 345)	1	2414 338-9	2414 338-9				
	(code 346)	1	2414 340-1	2414 340-1				
	(code 394)	1	2414 342-3	2414 342-3				
	(code 425)	1	2429 832					
	(code 447)	1	----	----	2429 293			
	(code 494)	1	2415 140	----	2429 702-3			
	P1-L, P2-L (plain design)	(code 411)	1	*2414 782				
		(code 413)	1	2414 783				
P1-M, P2-M (plain design)		(code 431)	1	*2414 782				
		(code 433)	1	2414 783				
P1, P2 (stitched design)		(codes 411, 431)	1	⊠2433 974				
		(codes 413, 433)	1	⊠2433 975				
P1-H, P2-H (code 441)	(code 443)	1	2414 546-7	2414 546-7	2414 546-7	2414 546-7	2414 546-7	
	(code 445)	1	2414 548-9	2414 548-9	2414 548-9	2414 548-9	2414 548-9	
	(code 446)	1	2414 550-1	2414 550-1	2414 550-1	2414 550-1	2414 550-1	
		1	----	----	----	----	2414 552-3	
P2-P (code 451)	(code 455)	2	----	----	----	2429 136	2429 136	
	(code 459)	2	----	----	----	2429 137	2429 137	
		2	----	----	----	2429 138	2429 138	
23-108-32	PANEL or COVER, Back of Front Seat Back P2-P							
	(code 451)	1	----	----	----	2429 154	2429 154	
	(code 455)	1	----	----	----	2429 155	2429 155	
	(code 459)	1	----	----	----	2429 156	2429 156	
23-108-57	NUT, Front Seat Cushion Bumper to Rear Rail P1, P2 (2 D.)							
		4	2094 869					

★ Indicates use as required.

⊠ Indicates parts not listed in any previous parts book.

Right and left part numbers are on same line, first number is right, second number is left.

* Indicates change or addition.

Prices and specifications subject to change without notice.

Jan. 3, 1964 Supersedes Jan. 25, 1963.

1963 PASSENGER CAR PARTS CATALOG

INTERIOR TRIM

CODE	REMARKS	PER CAR	SED.	SP. 4 D.	SUB.	SP. CL. CP.	CV. CP.
23-108-84	COVER, Front Seat Back Outer Hinge Arm P1, P2 (plastic) (chrome)	1	2413 568-9	2413 568-9	2413 568-9	2413 568-9	2413 568-9
23-108-98	SHIELD, Front Seat Side P1, P2 P2-P (stamping) (cushion) (die cast) (cushion) (back)	1 2 1 1	----- ----- ----- 2440 152-3	----- ----- ----- 2440 152-3	----- ----- ----- 2440 152-3	2440 152-3 *2440 340 *2292 492-3 2440 152-3	2440 152-3 *2440 340 *2292 492-3 2440 152-3
23-108-100	CUP WASHER, Front Seat Side Shield to Seat Frame, D1-H, D2-H	2	2419 974	2419 974	2419 974	2419 974	2419 974
23-109-3	BACK, Rear Seat P1, P2 (code 301) (w/heavy duty spring) (code 303) (w/heavy duty spring) (code 306) (w/heavy duty spring)	1 1 1 1 1 1	2411 292 2411 295 2411 293 2411 296 2411 294 2411 297				
	P1, P2 (plain design) (code 321) (w/heavy duty spring) (code 322) (w/heavy duty spring) (code 323) (w/heavy duty spring) (code 325) (w/heavy duty spring) (code 326) (w/heavy duty spring) (code 394)	1 1 1 1 1 1 1 1 1 1	*2411 507 2411 511 2411 508 2411 512 2411 509 2411 513 2429 194 2429 195 2411 510 2411 514 2429 841	----- ----- ----- ----- ----- ----- ----- ----- ----- -----	----- ----- ----- ----- ----- ----- ----- ----- ----- -----	*2411 507 2411 511 2411 509 2411 513 2429 194 2429 195 2411 510 2411 514	
	P1, P2 (stitched design) (code 321) (w/heavy duty spring) (code 322) (w/heavy duty spring) (code 323) (w/heavy duty spring) (code 325) (w/heavy duty spring) (code 326) (w/heavy duty spring)	1 1 1 1 1 1 1 1 1 1	⊕2433 773 ⊕2433 778 ⊕2433 774 ⊕2433 779 ⊕2433 775 ⊕2433 780 ⊕2433 776 ⊕2433 781 ⊕2433 777 ⊕2433 782	----- ----- ----- ----- ----- ----- ----- ----- ----- -----	----- ----- ----- ----- ----- ----- ----- ----- ----- -----	⊕2433 773 ⊕2433 778 ⊕2433 775 ⊕2433 780 ⊕2433 776 ⊕2433 781 ⊕2433 777 ⊕2433 782	
	P1-L, P2-L (plain design) (code 411) (code 413) (code 494) (w/heavy duty spring) (police)	1 1 1 1	*2414 796 2414 799 2414 947 2414 948				
	P1-M, P2-M (plain design) (code 431) (code 433)	1 1	*2414 797 2414 799				
	P1, P2 (stitched design) (codes 411, 431) (codes 413, 433)	1 1	⊕2433 986 ⊕2433 987				
	P2-H (code 441) (2nd. seat) (3rd. seat)	1 1	2414 699 -----	2414 699 -----	2429 622 2429 677	2414 699	2414 650

★ Indicates use as required.

⊕ Indicates parts not listed in any previous parts book.

Jan. 3, 1964 Supersedes Jan. 25, 1963.

Page IT-44

Printed in U.S.A.

Prices and specifications subject to change without notice.

Right and left part numbers are on same line,

first number is right, second number is left.

* Indicates change or addition.

CODE	REMARKS	PER CAR	SED.	SP. 4 D.	SUB.	SP. CL. CP.	CV. CP.
23-109-3	BACK, Rear Seat - Cont'd						
	P2-H						
	(code 442) (2nd. seat)	1	----	----		2429 623	
	(code 443) (3rd. seat)	1	----	----		2429 678	
	(code 443) (2nd. seat)	1	2414 700	2414 700		2429 624	2414 651
	(code 445) (3rd. seat)	1	----	----		2429 679	
	(code 445) (2nd. seat)	1	2414 701	2414 701		2429 625	2414 652
	(code 446) (3rd. seat)	1	----	----		2429 680	
	(code 446)	1	----	----		----	2414 653
	(code 447) (2nd. seat)	1	----	----		2429 626	
	(code 447) (3rd. seat)	1	----	----		2429 681	
	P2-P						
	(code 451)	1	----	----	----	2429 396	2429 432
	(code 455)	1	----	----	----	2429 397	2429 433
	(code 459)	1	----	----	----	2429 398	2429 434
	P1, P2 (4 D.)						
	(code 341)	1	2414 409	2414 409	----	2414 409	
	(code 342)	1	2414 410	2414 410	----	2414 410	
	(code 343)	1	2414 411	2414 411	----	2414 411	
	(code 345)	1	2414 412	2414 412	----	2414 412	
	(code 346)	1	2414 413	2414 413	----	2414 413	
	P1, P2 (sub. 2nd. seat)						
	(code 401)	1	----	----		2411 409	
	(code 403)	1	----	----		2411 410	
	(code 406)	1	----	----		2411 411	
	P1, P2 (plain design)						
	(code 421)	1	----	----		*2411 631	
	(code 423)	1	----	----		2411 633	
	(code 425)	1	----	----		2429 301	
	(code 426)	1	----	----		2411 634	
	P1, P2 (stitched design)						
	(code 421)	1	----	----		E2433 934	
	(code 423)	1	----	----		E2433 935	
	(code 425)	1	----	----		E2433 936	
	(code 426)	1	----	----		E2433 937	
	P1, P2 (sub. 3 rd. seat)						
	(code 401)	1	----	----		2411 430	
	(code 403)	1	----	----		2411 431	
	(code 406)	1	----	----		2411 432	
	P1, P2 (plain design)						
	(code 421)	1	----	----		*2411 659	
	(code 423)	1	----	----		2411 661	
	(code 425)	1	----	----		2429 308	
	(code 426)	1	----	----		2411 662	
	P1, P2 (stitched design)						
	(code 421)	1	----	----		E2433 962	
	(code 423)	1	----	----		E2433 963	
	(code 425)	1	----	----		E2433 964	
	(code 426)	1	----	----		E2433 965	
23-109-4	COVER, Rear Seat Back						
	P1, P2						
	(code 301)	1	2411 286				
	(code 303)	1	2411 287				
	(code 306)	1	2411 288				
	P1, P2 (plain design)						
	(code 321)	1	*2411 499	----	----	*2411 499	
	(code 322)	1	2411 500				

★ Indicates use as required.
 ☐ Indicates parts not listed in any previous parts book.
 Right and left part numbers are on same line,
 first number is right, second number is left.
 * Indicates change or addition.

Printed in U.S.A.
 Prices and specifications subject to change without notice.
 Jan. 3, 1964 Supersedes Sept. 4, 1962.

1963 PASSENGER CAR PARTS CATALOG

INTERIOR TRIM

CODE	REMARKS	PER CAR	SED.	SP. 4 D.	SUB.	SP. CL. CP.	CV. CP.
23-109-4	COVER, Rear Seat Back - Cont'd P1, P2 (plain design)						
	(code 323)	1	2411 501	----	----	2411 501	
	(code 325)	1	2429 193	----	----	2429 193	
	(code 326)	1	2411 502	----	----	2411 502	
	P1, P2 (stitched design)						
	(code 321)	1	E2433 768	----	----	E2433 768	
	(code 322)	1	E2433 769	----	----	E2433 769	
	(code 323)	1	E2433 770	----	----	E2433 770	
	(code 325)	1	E2433 771	----	----	E2433 771	
	(code 326)	1	E2433 772	----	----	E2433 772	
	P1, P2						
	(code 341) (4 D.)	1	2414 399	2414 399	----	2414 399	
	(code 342)	1	2414 400	2414 400	----	2414 400	
	(code 343)	1	2414 401	2414 401	----	2414 401	
	(code 345)	1	2414 402	2414 402	----	2414 402	
	(code 346)	1	2414 403	2414 403	----	2414 403	
	(code 394) (police) (2 D. & 4 D.)	1	2429 840				
	P1, P2						
	(code 441)	1	2414 681	2414 681	----	2414 681	2414 586
	(code 443)	1	2414 682	2414 682	----	2414 682	2414 587
	(code 445) (2nd. seat)	1	2414 683	2414 683	2429 590	2414 683	2414 588
	(code 446)	1	----	----	----	----	2414 589
	(code 447) (2nd. seat)	1	----	----	2429 591	----	
	(code 451)	1	----	----	----	2429 393	2429 429
	(code 455)	1	----	----	----	2429 394	2429 430
	(code 459)	1	----	----	----	2429 395	2429 431
	P1, P2 (sub. 2nd. seat)						
	(code 401)	1	----	----	2411 406		
	(code 403)	1	----	----	2411 407		
	(code 406)	1	----	----	2411 408		
	P1, P2 (plain design)						
	(code 421)	1	----	----	*2411 623		
	(code 422)	1	----	----	2411 624		
	(code 423)	1	----	----	2411 625		
	(code 425)	1	----	----	2429 300		
	(code 426)	1	----	----	2411 626		
	P1, P2 (stitched design)						
	(code 421)	1	----	----	E2433 922		
	(code 423)	1	----	----	E2433 923		
	(code 425)	1	----	----	E2433 924		
	(code 426)	1	----	----	E2433 925		
	(code 441)	1	----	----	2429 587		
	(code 442)	1	----	----	2429 588		
	(code 443)	1	----	----	2429 589		
	P1, P2 (sub. 3rd. seat)						
	(code 401)	1	----	----	2411 424		
	(code 403)	1	----	----	2411 425		
	(code 406)	1	----	----	2411 426		
	P1, P2 (plain design)						
	(code 421)	1	----	----	*2411 651		
	(code 423)	1	----	----	2411 653		
	(code 425)	1	----	----	2429 307		
	(code 426)	1	----	----	2411 654		

★ Indicates use as required.

E Indicates parts not listed in any previous parts book.
Jan. 3, 1964 Supersedes Sept. 4, 1962.

Printed in U.S.A.

Prices and specifications subject to change without notice.
Right and left part numbers are on same line,
first number is right, second number is left.

* Indicates change or addition.

CODE	REMARKS	N PER CAR	SED.	SP. 4 D.	SUB.	SP. CL. CP.	CV. CP.
23-109-4	COVER, Rear Seat Back-Cont'd P1, P2 (stitched design)						
	(code 421)	1	----	----	E2433 954		
	(code 423)	1	----	----	E2433 955		
	(code 425)	1	----	----	E2433 956		
	(code 426)	1	----	----	E2433 957		
	(code 441)	1	----	----	2429 657		
	(code 442)	1	----	----	2429 658		
	(code 443)	1	----	----	2429 659		
	(code 445)	1	----	----	2429 660		
	(code 447)	1	----	----	2429 661		
	P1-L (plain design)						
	(code 411)	1	*2414 796				
	(code 413)	1	2414 797				
	P2-M (plain design)						
	(code 431)	1	*2414 796				
	(code 433)	1	2414 797				
	P1, P2 (stitched design)						
	(codes 411, 431)	1	E2433 984				
	(codes 413, 433)	1	E2433 985				
	P1-L, P2-L						
	(code 494)	1	2414 946				
	(seat back spring attaching screw)	3	----	----	6000 234		
23-109-5	INSERT or COVER, Rear Seat Back Rear Panel						
	P1, P2 (sub. 2nd. seat)						
	(codes 401, 421, 441)						
	(blue)	1	----	----	2297 561		
	(codes 403, 423, 443)						
	(tan)	1	----	----	2297 562		
	(codes 406, 425, 447)						
	(black)	1	----	----	2297 564		
	(codes 425, 445) (red)	1	----	----	E1804 TR6		
	(code 442) (green)	1	----	----	2297 566		
	P1, P2 (sub. 3 rd. seat)						
	(codes 401, 421, 441)						
	(blue)	1	----	----	2297 567		
	(codes 403, 423, 443)						
	(tan)	1	----	----	2297 568		
	(codes 406, 426, 447)						
	(black)	1	----	----	2297 570		
	(codes 425, 445) (red)	1	----	----	E1805 TR6		
	(code 442) (green)	1	----	----	2297 572		
	(back support panel)						
	(codes 401, 421, 441)						
	(blue)	1	----	----	2297 591		
	(codes 403, 423, 443)						
	(tan)	1	----	----	2297 592		
	(codes 406, 426, 447)						
	(black)	1	----	----	2297 594		
	(codes 425, 445) (red)	1	----	----	2297 593		
	(code 442) (green)	1	----	----	2297 596		
	P2 (upper panel)						
	(paint as required)	1	----	----	----	----	2413 817

★ Indicates use as required.
 E Indicates parts not listed in any previous parts book.
 Right and left part numbers are on same line,
 first number is right, second number is left.
 * Indicates change or addition.

1963 PASSENGER CAR PARTS CATALOG

INTERIOR TRIM

CODE	REMARKS	PER CAR	SED.	SP. 4 D.	SUB.	SP. CL. CP.	CV. CP.
23-109-35	CUSHION, Rear Seat						
	P1, P2						
	(code 301)	1	2411 277				
	(w/heavy duty spring)	1	2411 280				
	(w/airfoam pad and heavy duty spring)	1	2411 283				
	(code 303)	1	2411 278				
	(w/heavy duty spring)	1	2411 281				
	(w/airfoam pad and heavy duty spring)	1	2411 284				
	(code 306)	1	2411 279				
	(w/heavy duty spring)	1	2411 285				
	(w/airfoam pad and heavy duty spring)	1	2411 282				
	(code 325)	1	2429 189	----	----	2429 189	
	(w/heavy duty spring and airfoam pad)	1	2429 191	----	----	2429 191	
	(w/heavy duty spring)	1	2429 190	----	----	2429 190	
	(code 394)	1	2429 837				
	(w/airfoam pad)	1	2429 838				
	P1, P2 (plain design)						
	(code 321)	1	*2411 487	----	----	*2411 487	
	(w/heavy duty spring)	1	2411 491	----	----	2411 491	
	(w/airfoam pad and heavy duty spring)	1	2411 495	----	----	2411 495	
	(code 322)	1	2411 488				
	(w/heavy duty spring)	1	2411 492				
	(w/airfoam pad and heavy duty spring)	1	2411 496				
	(code 323)	1	2411 489	----	----	2411 489	
	(w/heavy duty spring)	1	2411 493	----	----	2411 493	
	(w/airfoam pad and heavy duty spring)	1	2411 497	----	----	2411 497	
	(code 326)	1	2411 490	----	----	2411 490	
	(w/heavy duty spring)	1	2411 494	----	----	2411 494	
	(w/airfoam pad and heavy duty spring)	1	2411 498	----	----	2411 498	
	P1, P2 (stitched design)						
	(code 321)	1	E2433 743	----	----	E2433 743	
	(w/heavy duty spring)	1	E2433 748	----	----	E2433 748	
	(w/airfoam pad and heavy duty spring)	1	E2433 753	----	----	E2433 753	
	(code 322)	1	E2433 744	----	----	E2433 744	
	(w/heavy duty spring)	1	E2433 749	----	----	E2433 749	
	(w/airfoam pad and heavy duty spring)	1	E2433 754	----	----	E2433 754	
	(code 323)	1	E2433 745	----	----	E2433 745	
	(w/heavy duty spring)	1	E2433 750	----	----	E2433 750	
	(w/airfoam pad and heavy duty spring)	1	E2433 755	----	----	E2433 755	
	(code 325)	1	E2433 746	----	----	E2433 746	
	(w/heavy duty spring)	1	E2433 751	----	----	E2433 751	
	(w/airfoam pad and heavy duty spring)	1	E2433 756	----	----	E2433 756	
	(code 326)	1	E2433 747	----	----	E2433 747	
	(w/heavy duty spring)	1	E2433 752	----	----	E2433 752	
	(w/airfoam pad and heavy duty spring)	1	E2433 757	----	----	E2433 757	
	P1, P2 (4 D.)						
	(code 341)	1	2414 389	2414 389	----	2414 389	
	(w/airfoam pad)	1	2414 394	2414 394	----	2414 394	

★ Indicates use as required.

E Indicates parts not listed in any previous parts book.

Jan. 3, 1964 Supersedes Dec. 14, 1962.

Page IT-48

Printed in U.S.A.

Prices and specifications subject to change without notice.

Right and left part numbers are on same line, first number is right, second number is left.

* Indicates change or addition.

CODE	REMARKS	PER CAR	SED.	SP. 4 D.	SUB.	SP. CL. CP.	CV. CP.
23-109-35	CUSHION, Rear Seat - Cont'd						
	P1, P2 (4 D.)						
	(code 342)	1	2414 390	2414 390	----	2414 390	
	(w/airfoam pad)	1	2414 395	2414 395	----	2414 395	
	(code 343)	1	2414 391	2414 391	----	2414 391	
	(w/airfoam pad)	1	2414 396	2414 396	----	2414 396	
	(code 345)	1	2414 392	2414 392	----	2414 392	
	(w/airfoam pad)	1	2414 397	2414 397	----	2414 397	
	(code 346)	1	2414 393	2414 393	----	2414 393	
	(w/airfoam pad)	1	2414 398	2414 398	----	2414 398	
	P1-L						
	(code 411)	1	2414 792				
	(code 413)	1	2414 793				
	P2-M						
	(code 431)	1	2414 792				
	(code 433)	1	2414 793				
	(code 401) (2nd. seat)	1	----	----	2411 400		
	(3rd. seat)	1	----	----	2411 421		
	(code 403) (2nd. seat)	1	----	----	2411 401		
	(3rd. seat)	1	----	----	2411 422		
	(code 406) (2nd. seat)	1	----	----	2411 402		
	(3rd. seat)	1	----	----	2411 423		
	P2-M (plain design)						
	(code 421) (2nd. seat)	1	----	----	*2411 619		
	(3rd. seat)	1	----	----	2411 647		
	(code 423) (2nd. seat)	1	----	----	2411 621		
	(3rd. seat)	1	----	----	2411 649		
	(code 425) (2nd. seat)	1	----	----	2429 299		
	(3rd. seat)	1	----	----	2429 306		
	(code 426) (2nd. seat)	1	----	----	2411 622		
	(3rd. seat)	1	----	----	2411 650		
	P2-M (2nd. seat)(stitched design)						
	(code 421)	1	----	----	⊕2433 918		
	(code 423)	1	----	----	⊕2433 919		
	(code 425)	1	----	----	⊕2433 920		
	(code 426)	1	----	----	⊕2433 921		
	P2-M (3rd. seat)(stitched design)						
	(code 421)	1	----	----	⊕2433 950		
	(code 423)	1	----	----	⊕2433 951		
	(code 425)	1	----	----	⊕2433 952		
	(code 426)	1	----	----	⊕2433 953		
	P1-H, P2-H						
	(code 441) (2nd. seat)	1	2414 675	2414 675	2429 577	2414 675	2414 626
	(w/airfoam pad)	1	2414 678	2414 678	2429 582	2414 678	2414 630
	(3rd. seat)	1	----	----	2429 652		
	(code 442) (2nd. seat)	1	----	----	2429 578		
	(w/airfoam pad)	1	----	----	2429 583		
	(3rd. seat)	1	----	----	2429 653		
	(code 443) (2nd. seat)	1	2414 676	2414 676	2429 579	2414 676	2414 627
	(w/airfoam pad)	1	2414 679	2414 679	2429 584	2414 679	2414 631
	(3rd. seat)	1	----	----	2429 654		
	(code 445) (2nd. seat)	1	2414 677	2414 677	2429 580	2414 677	2414 628
	(w/airfoam pad)	1	2414 680	2414 680	2429 585	2414 680	2414 632
	(3rd. seat)	1	----	----	2429 655		
	(code 446) (w/airfoam pad)	1	----	----	----	----	2414 629
	(code 447) (2nd. seat)	1	----	----	2429 581	----	2414 633
	(w/airfoam pad)	1	----	----	2429 586		
	(3rd. seat)	1	----	----	2429 656		

★ Indicates use as required.

⊕ Indicates parts not listed in any previous parts book.

Right and left part numbers are on same line, first number is right, second number is left.

* Indicates change or addition.

Printed in U.S.A.
Prices and specifications subject to change without notice.
Jan. 3, 1964 Supersedes Jan. 25, 1963.

1963 PASSENGER CAR PARTS CATALOG

INTERIOR TRIM

CODE	REMARKS	PER CAR	SED.	SP. 4 D.	SUB.	SP. CL. CP.	CV. CP.
23-109-35	CUSHION, Rear Seat - Cont'd P2-P						
	(code 451)	1	----	----	----	2429 381	2429 414
	(code 455)	1	----	----	----	2429 382	2429 415
	(code 459)	1	----	----	----	2429 383	2429 416
	(third seat cushion spring attaching screw)	3	----	----	----	----	6000 234
23-109-36	COVER, Rear Seat Cushion P1, P2						
	(code 301)	1	2411 274				
	(code 303)	1	2411 275				
	(code 306)	1	2411 276				
	P1, P2 (plain design)						
	(code 321)	1	*2411 479	----	----	*2411 479	
	(code 322)	1	2411 480				
	(code 323)	1	2411 481			2411 481	
	(code 325)	1	2429 188			2429 188	
	(code 326)	1	2411 482			2411 482	
	P1, P2 (stitched design)						
	(code 321)	1	⊠2433 738	----	----	⊠2433 738	
	(code 322)	1	⊠2433 739	----	----	⊠2433 739	
	(code 323)	1	⊠2433 740	----	----	⊠2433 740	
	(code 325)	1	⊠2433 741	----	----	⊠2433 741	
	(code 326)	1	⊠2433 742	----	----	⊠2433 742	
	P1, P2						
	(code 341) (4 D.)	1	2414 384	2414 384	----	2414 384	
	(code 342)	1	2414 385	2414 385	----	2414 385	
	(code 343)	1	2414 386	2414 386	----	2414 386	
	(code 345)	1	2414 387	2414 387	----	2414 387	
	(code 346)	1	2414 388	2414 388	----	2414 388	
	(code 394)	1	2429 836	----	----	----	
	P1, P2						
	(code 401) (sub. 2nd. seat)	1	----	----	2411 397		
	(sub. 3rd. seat)	1	----	----	2411 418		
	(code 403) (sub. 2nd. seat)	1	----	----	2411 398		
	(sub. 3rd. seat)	1	----	----	2411 419		
	(code 406) (sub. 2nd. seat)	1	----	----	2411 399		
	(sub. 3rd. seat)	1	----	----	2411 420		
	P1, P2 (plain design)						
	(code 421) (sub. 2nd. seat)	1	----	----	*2411 611		
	(sub. 3rd. seat)	1	----	----	2411 639		
	(code 423) (sub. 2nd. seat)	1	----	----	2411 613		
	(sub. 3rd. seat)	1	----	----	2411 641		
	(code 426) (sub. 2nd. seat)	1	----	----	2411 614		
	P1, P2 (2nd. seat)(stitched design)						
	(code 421)	1	----	----	⊠2433 906		
	(code 423)	1	----	----	⊠2433 907		
	(code 425)	1	----	----	⊠2433 908		
	(code 426)	1	----	----	⊠2433 909		
	P1, P2 (3rd. seat)(stitched design)						
	(code 421)	1	----	----	⊠2433 942		
	(code 423)	1	----	----	⊠2433 943		
	(code 425)	1	----	----	⊠2433 944		
	(code 426)	1	----	----	⊠2433 945		

★ Indicates use as required.

⊠ Indicates parts not listed in any previous parts book.

Jan. 3, 1964 Supersedes Jan. 25, 1963.

Printed in U.S.A.

Prices and specifications subject to change without notice.

Right and left part numbers are on same line,
first number is right, second number is left.

* Indicates change or addition.

CODE	REMARKS	PER CAR	SED.	SP. 4D.	SUB.	SP. CL. CP.	CV. CP.
23-109-36	COVER, Rear Seat Cushion - Cont'd P1, P2						
	(code 441) (sub. 2nd. seat)	1	*2414 672	*2414 672	*2429 572	*2414 672	*2414 598
	(3rd. seat)	1	----	----	2429 632		
	(code 442) (2nd. seat)	1	----	----	2429 573		
	(3rd. seat)	1	----	----	2429 633		
	(code 443) (sub. 2nd. seat)	1	2414 673	2414 673	2429 574	2414 673	2414 599
	(3rd. seat)	1	----	----	2429 634		
	(code 445) (2nd. seat)	1	2414 674	2414 674	2429 575	2414 674	2414 600
	(3rd. seat)	1	----	----	2429 635		
	(code 446)	1	----	----	----	----	2414 601
	(code 447) (sub. 2nd. seat)	1	----	----	2429 576		
	(3rd. seat)	1	----	----	2429 636		
	(code 425) (2nd. seat)	1	----	----	2429 298		
	(3rd. seat)	1	----	----	2429 305		
	P1-L, P2-L (code 411)	1	2414 790				
	(code 413)	1	2414 791				
	P1-M, P2-M (code 431)	1	2414 790				
	(code 433)	1	2414 791				
	(code 451)	1	----	----	----	2429 378	2429 411
	(code 455)	1	----	----	----	2429 379	2429 412
	(code 459)	1	----	----	----	2429 380	2429 413
23-109-38	RETAINER, Rear Seat Cushion P1, P2	2	1810 037	1810 037	1810 037	1810 037	1810 037
	(rear floor pan 3rd. seat cushion rear)	2	----	----	2422 981		
23-111-37	STRIP, Folding Top Bow Tacking P2-H (No. 1 and No. 2) (No. 3)	1	----	----	----	----	1950 509
		1	----	----	----	----	*2424 607
23-112-12	BOOT, Folding Top Dust P2 (w/4 pocket panel fasteners)						
	(codes 441,451)	1	----	----	----	----	B2432 952
	(code 443)	1	----	----	----	----	B2432 953
	(codes 445,455)	1	----	----	----	----	B2432 954
	(code 446)	1	----	----	----	----	B2432 955
	(code 459)	1	----	----	----	----	*2432 957
	P2 (w/8 pocket panel fasteners)						
	(codes 441,451)	1	----	----	----	----	B2432 990
	(code 443)	1	----	----	----	----	B2432 991
	(codes 445,455)	1	----	----	----	----	B2432 992
	(code 446)	1	----	----	----	----	B2432 993
	(code 459)	1	----	----	----	----	B2432 995
23-112-18	RETAINER, Channel Rear Seat Back Dust Boot P2-H, P2-P	1	----	----	----	----	2270 167
23-112-19	INSERT, Rear Seat Back Dust Boot Cover P2-H, P2-P (vinyl)	1	----	----	----	----	2160 328
23-112-45	CURTAIN, Folding Top P2 (black)	1	----	----	----	----	2429 746
	(white)	1	----	----	----	----	2433 638
	(check strap to bow cap)	1	----	----	----	----	6000 434
	BACK LIGHT, Folding Top P2	1	----	----	----	----	2429 827

★ Indicates use as required.
 □ Indicates parts not listed in any previous parts book.
 Right and left part numbers are on same line,
 first number is right, second number is left.
 * Indicates change or addition.

Printed in U.S.A.
 Prices and specifications subject to change without notice.
 Jan. 3, 1964 Supersedes Dec. 14, 1962.

1963 PASSENGER CAR PARTS CATALOG

INTERIOR TRIM

CODE	REMARKS	PER CAR	SED.	SP. 4 D.	SUB.	SP. CL. CP.	CV. CP.
23-112-46	ZIPPER, Folding Top Curtain P2-H, P2-P (black)	1	-----	-----	-----	-----	2273 435
23-112-50	TAPE, Folding Top Back Curtain Quarter Stay Closure Hook (service by the inch) P2 Side Closure Loop (service by the inch) P2	★ ★	----- -----	----- -----	----- -----	----- -----	*1934 TX8 *1933 TX8
23-112-70	RETAINER, Folding Top Belt Bar P2 (center) (galvanized) (side) (galvanized) (center) (side) (rear)	1 1 1 1 1	----- ----- ----- ----- -----	----- ----- ----- ----- -----	----- ----- ----- ----- -----	----- ----- ----- ----- -----	2189 748 2189 852-3 2421 694 2421 944-5 2421 939
23-112-75	END, Folding Top Wire on Binding P2	1	-----	-----	-----	-----	1158 976-7
23-112-88	CABLE, Folding Top Rear Bow Tension P2	2	-----	-----	-----	-----	2166 660
23-112-108	TOP DECK and SIDE QUARTER P2 (black) (white)	1 1	----- -----	----- -----	----- -----	----- -----	2429 748 2429 749
23-112-112	PAD, Folding Top Side Quarter Stay P2 (black)	1	-----	-----	-----	-----	B2429 750-1
23-112-153	PANEL or COVER, Rear Quarter Pocket P2 (panel) (w/o arm rest) (codes 441, 451) (code 443) (codes 445, 455) (code 446) (code 459) (panel and reinforcement) (paint as required) (used w/arm rest pad, code 23-112-160)	1 1 1 1 1 1	----- ----- ----- ----- ----- -----	----- ----- ----- ----- ----- -----	----- ----- ----- ----- ----- -----	----- ----- ----- ----- ----- -----	*2429 758-9 2429 760-1 2429 762-3 2429 764-5 2429 766-7 B2432 468-9
	P2 (cover) (codes 441, 451) (code 443) (codes 445, 455) (code 446) (code 459) (well cover) (codes 441, 451) (code 443) (codes 445, 455) (codes 446, 459) (well cover to quarter belt bar screw)	1 1 1 1 1 1 1 1 1 2	----- ----- ----- ----- ----- ----- ----- ----- ----- -----	----- ----- ----- ----- ----- ----- ----- ----- ----- -----	----- ----- ----- ----- ----- ----- ----- ----- ----- -----	----- ----- ----- ----- ----- ----- ----- ----- ----- -----	2431 890-1 2431 892-3 2431 894-5 2431 896-7 2431 934-5 2429 709 2429 710 2429 711 2429 712 6023 381
23-112-160	PAD, Folding Top Pocket Panel Arm Rest P2 (codes 441, 461) (code 443)	1 1	----- -----	----- -----	----- -----	----- -----	2432 874-5 2432 876-7

★ Indicates use as required.

B Indicates parts not listed in any previous parts book.
Jan. 3, 1964 Supersedes Sept. 4, 1962.Printed in U.S.A.
Prices and specifications subject to change without notice.
Right and left part numbers are on same line,
first number is right, second number is left.
* Indicates change or addition.

CODE	REMARKS	PER CAR	SED.	SP. 4 D.	SUB.	SP. CL. CP.	CV. CP.
23-112-160	PAD, Folding Top Pocket Panel Arm Rest - Cont'd P2 (codes 445, 455) (code 446) (code 459)	1 1 1	----- ----- -----	----- ----- -----	----- ----- -----	----- ----- -----	2432 878-9 2432 880-1 2432 882-3
23-113-45	WEATHERCORD, Quarter Window Opening P1, P2 (2 D.) (codes 301, 321) (blue) (code 322) (codes 303, 323) (tan) (code 306) (black) (code 325) (red) (code 326) (alabaster) (code 494) (gray)	2 1 1 1 2 1 ★	⊕2432 944 ⊕2432 945 ⊕2432 930-1 ⊕1512-3 TX8 *1515 TR6 2413 404-5 2413 366				
23-113-84	WELT, Folding Top Header P2 (black)	1	-----	-----	-----	-----	*2432 150
23-113-87	WELT, Quarter Panel Flange Cover P1, P2 (rubber)	★	2292 592	2292 592	-----	2292 592	2292 592
23-114-2	MATERIAL, Seat Cloth Trim P1-L, P2-L (62" wide) (code 301) (blue) (code 303) (tan) (code 306) (alabaster) P1-M, P2-M (23" wide) (code 321) (blue) (code 322) (green) (code 323) (tan) (code 325) (red) (code 326) (alabaster) P1-H, P2-H (63" wide) (code 341) (blue) (code 342) (green) (code 343) (tan) (code 345) (red) (code 346) (alabaster)	★ ★ ★ ★ ★ ★ ★ ★ ★ ★ ★ ★ ★	*2185 862 2185 863 2185 864 *2185 976 2185 977 2185 978 2186 085 2185 979 *2185 865 2185 866 2185 867 2185 868 2185 869			*2185 976 2185 977 2185 978 2186 085 2185 979	
23-114-10	BINDING (5/8" wire on) P2 (black) (white)	★ ★	----- -----	----- -----	----- -----	----- -----	2171 884 2177 529
23-114-15	MATERIAL, Leather (Imitation) P1, P2 (codes 301, 401) (28-AM-22) (50") (1602 blue) (28A-AM-22) (50") (1600 blue) (codes 321, 341, 411, 421, 431, 441) (28-AM-22) (50") (1604 blue) (code 401) (26-DL-73) (47") (1601-1 blue) (code 421) (23-EA-12) (44") (1601 medium blue) (code 441) (23-DW-79) (40") (1663 dark blue)	★ ★ ★ ★ ★ ★ ★	2185 647 2185 778 2185 615 ----- ----- ----- -----			2185 647 2185 778 2185 615 2185 700 ⊕2186 323 ⊕2186 193	2185 615 ⊕2186 193

★ Indicates use as required.
 ⊕ Indicates parts not listed in any previous parts book.
 Right and left part numbers are on same line,
 first number is right, second number is left.
 * Indicates change or addition.

CODE	REMARKS	PER CAR	SED.	SP. 4 D.	SUB.	SP. CL. CP.	CV. CP.
23-114-15	MATERIAL, Leather (Imitation) - Cont'd P1, P2 (codes 301, 401, 411) (19-DJ-22) (54") (1600 light blue)	★	*2186 097	----	*2186 097		
	(codes 321, 341, 421, 431, 441) (19-DJ-22) (54") (1601 medium blue)	★	*2185 798	*2185 798	*2185 798	*2185 798	*2185 798
	(codes 341, 441) (19-DJ-79) (54") (1663 dark blue gloss)	★	*2185 853	*2185 853	*2185 853	*2185 853	*2185 853
	(codes 321, 421, 431, 451) (18-DN-22) (54") (1657 pale blue)	★	*2186 061	----	*2186 061	*2186 061	*2186 061
	(code 421) (22-DM-12) (42") (1601 blue)	★	----	----	*2185 715		
	(codes 301, 321, 421) (19-DK-72) (55") (1601 blue)	★	2185 697	----	----	2185 697	
	(codes 301, 321, 341, 401, 411, 441, 451) (19-BC-22) (54") (1601 blue)	★	----	*2185 620	*2185 620	*2185 620	*2185 620
	(codes 303, 323, 343, 403, 413, 423, 433, 443) (28-AM-22) (50") (1607 tan)	★	*2185 617	*2185 617	*2185 617	*2185 617	*2185 617
	(code 403) (26-DL-73) (47") (1607-1 tan)	★	----	----	2185 701		
	(code 443) (23-DW-79) (40") (1664 dark tan)	★	⊠2186 194	⊠2186 194	⊠2186 194	⊠2186 194	⊠2186 194
	(codes 303, 403, 413) (19-DJ-22) (54") (1606 light tan)	★	*2186 098	----	*2186 098		
	(codes 323, 343, 423, 433, 443) (19-DJ-22) (54") (1607 medium tan)	★	*2185 800	*2185 800	*2185 800	*2185 800	*2185 800
	(codes 343, 443) (19-DJ-79) (54") (1664 dark tan gloss)	★	*2185 854	*2185 854	*2185 854	*2185 854	*2185 854
	(code 423) (22-DM-12) (42") (1607 tan)	★	----	----	⊠2185 717		
	(code 443) (19-C-22) (54") (1607 tan)	★	*2185 622	*2185 622	*2185 622	*2185 622	*2185 622
	(codes 303, 323, 423) (19-DK-72) (55") (1607 tan)	★	2185 698	----	2185 698	2185 698	
	(codes 322, 342, 442) (28A-AM-22) (50") (1605 dark green)	★	*2185 648	*2185 648	----	*2185 648	
	(28-AM-22) (50") (1604 green)	★	2185 616	2185 616	2185 616	2185 616	
	(19-C-22) (54") (1604 green)	★	2185 621	2185 621	2185 621	2185 621	
	(19-DJ-22) (54") (1604 green)	★	2185 799	2185 799	2185 799	2185 799	
	(codes 322, 342) (19-DK-72) (55") (1604 green)	★	*2185 708				
	(19-AC-22) (54") (1605 green)	★	*2185 626	*2185 626	----	*2185 626	
	(codes 306, 406) (28A-AM-22) (50") (1617 alabaster)	★	2185 630	----	2185 630		
	(26-DL-73) (47") (1617 alabaster)	★	----	----	2185 702		

★ Indicates use as required.

⊠ Indicates parts not listed in any previous parts book.

January 3, 1964.

Page IT-52B

Printed in U.S.A.
Prices and specifications subject to change without notice.Right and left part numbers are on same line,
first number is right, second number is left.

* Indicates change or addition.

CODE	REMARKS	PER CAR	SED.	SP. 4D.	SUB.	SP. CL. CP.	CV. CP.
23-114-15	MATERIAL, Leather (Imitation) - Cont'd P1, P2 (codes 306, 326, 346, 406, 426, 446, 447) (28-AM-22) (50") (1617 alabaster)	★	*2185 630	*2185 630	*2185 630	*2185 630	*2185 630
	(codes 426, 446) (24-DM-12) (42") (1617 alabaster) (23-DW-79) (40") (1617 alabaster)	★	----	----	2185 718	----	2186 196
	(codes 306, 326, 426) (19-DK-72) (55") (1617 alabaster)	★	2185 699	----	2185 699	2185 699	
	P1, P2 (codes 325, 345, 425, 445, 455) (28-AM-22) (50") (1621 red) (code 425) (24-DM-12) (42") (1621 red) (code 445) (23-DW-79) (40") (1621 red) (codes 325, 425) (19-DK-72) (55") (1621 red) (codes 325, 345, 445) (19-C-22) (54") (1621 red)	★	*2185 721	*2185 721	----	*2185 721	*2185 721
		★	----	----	2186 091		
		★	2185 195	2185 195	----	2185 195	2185 195
		★	2186 086	----	2186 086	2186 086	
		★	2185 723	2185 723	2185 723	2185 723	2185 723
	(codes 326, 346, 406, 446) (19-C-22) (54") (1617 alabaster) (codes 302, 326, 346, 406, 426, 446) (19-DJ-22) (54") (1627 alabaster) (codes 323, 325, 423, 425, 433) (18-DN-22) (54") (1617 alabaster)	★	2185 631	2185 631	2185 631	2185 631	2185 631
		★	2185 802	2185 802	2185 802	2185 802	2185 802
		★	2185 765	----	2185 765	2185 765	2185 765
	(code 451) (19-DJ-79) (54") (1601 blue)	★	----	----	----	2186 058	2186 058
	(19-AC-22) (54") (1602 blue)	★	----	----	----	2185 625	2185 625
	(18-DN-22) (54") (1657 blue) (code 455)	★	----	----	----	2186 061	2186 061
	(19-C-22) (54") (1621 red)	★	----	----	----	2185 723	2185 723
	(19-AC-22) (54") (1621 red)	★	----	----	----	2185 723	2185 723
	(19-DJ-79) (54") (1621 red) (codes 445, 455)	★	----	----	----	2186 059	2186 059
	(23-DW-79) (40") (1621 red)	★	----	----	B2186 195		
	(codes 325, 345, 425, 445) (19-DJ-22) (54") (1621 red) (codes 326, 346, 394, 459) (28A-AM-22) (54") (1624 black) (codes 447, 459) (23-DW-79) (40") (1624 black) (code 459)	★	*2185 801	*2185 801	*2185 801	*2185 801	*2185 801
	(19-AC-22) (54") (1624 black)	★	*2185 659	*2185 659	----	*2185 659	*2185 659
	(19-DJ-79) (54") (1624 black)	★	----	----	B2186 197	----	B2186 197
	(18-DN-22) (54") (1668-1 copper metal)	★	----	----	----	2185 632	2185 632
		★	----	----	----	2186 060	2186 060
		★	----	----	----	2186 062	2186 062
	(code 494) (37-CX-22) (50") (902 gray) (code 394) (28-AM-22) (50") (1609 gray)	★	B2185 119				
		★	*2185 780				

★ Indicates use as required.
 B Indicates parts not listed in any previous parts book.
 Right and left part numbers are on same line,
 first number is right, second number is left.
 * Indicates change or addition.

