

1963 DODGE  
1963 DART**INTERIOR TRIM****HOW TO USE INTERIOR TRIM ILLUSTRATIONS**

The illustrations in this section are actual and each body style showing the Interior Trim is included.

The letters shown on the illustration indicate the description of the part and the part type code when referred to the legend which appears preceding the listing of the parts. The letters are consistent throughout the illustrations as "A" is always a Door Trim Panel, Code 23-92-5.

The numbers on the illustration indicate the distribution of material and type of material used. The numbers may vary with each illustration. The legend appears on the illustration.

For complete information on "How to Order" Trim Parts, see Mopar Parts Price List.

1963 DODGE - T SERIES

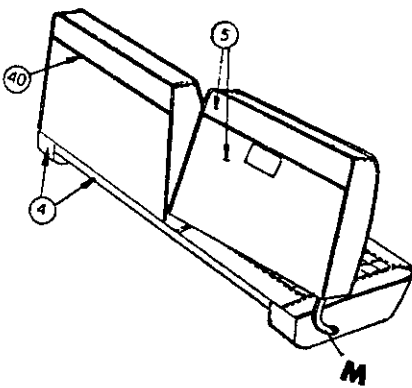
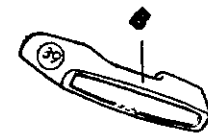
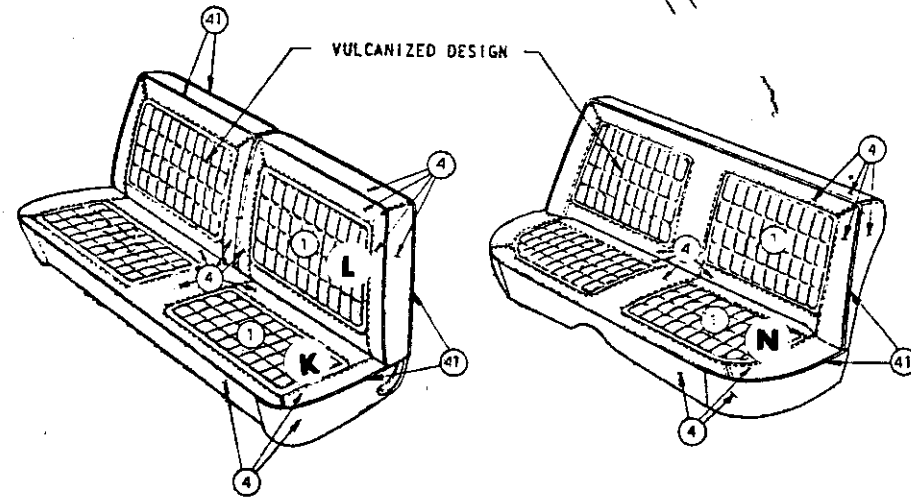
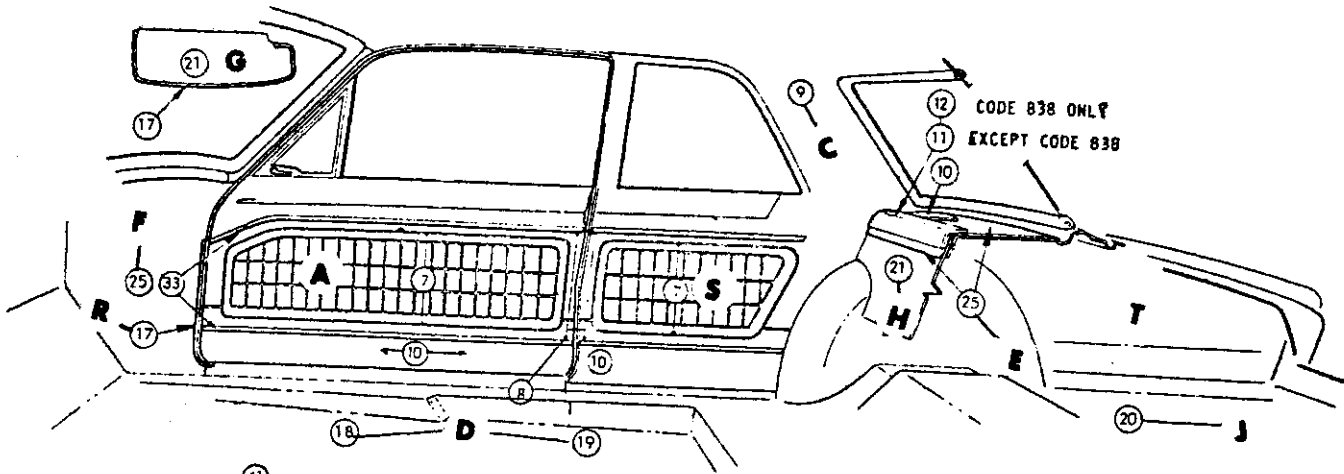

DISTRIBUTION OF MATERIAL

- 1 BODY CLOTH
- 4 IMITATION LEATHER
- 5 IMITATION LEATHER
- 7 IMITATION LEATHER
- 8 IMITATION LEATHER
- 9 IMITATION LEATHER
- 10 IMITATION LEATHER
- 11 IMITATION LEATHER
- 12 IMITATION LEATHER
- 16 LACE
- 17 EXTRUDED VINYL
- 18 FLOOR COVERING-FRONT-CARPET
- 19 FLOOR COVERING-REAR-CARPET
- 20 FLOOR COVERING-LUGG. COMPT. PRINTED JUTE
- 21 EMBOSSED CARDBOARD
- 24 FACING FABRIC
- 25 HARDBOARD
- 30 PLASTIC
- 31 PAINT
- 32 METAL
- 33 MOULDING
- 36 MYLAR
- 38 MOULDED RESIN
- 39 PLASTISOL
- 40 EXTRUDED VINYL NO. 2
- 41 EXTRUDED VINYL NO. 1

Distribution Drawing Legend Page Appears Following Illustration Section

Codes 831, 833, 835, 838

TLH-211

1963 DODGE TL1-H 2 DOOR SEDAN  
CLOTH & IMITATION LEATHER

1963 DODGE - T SERIES

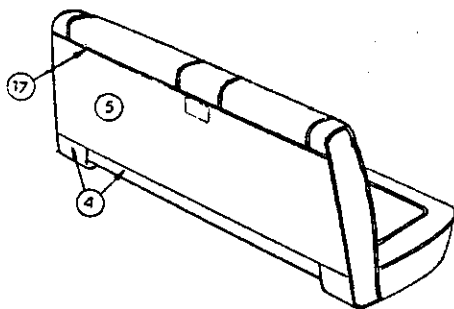
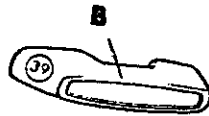
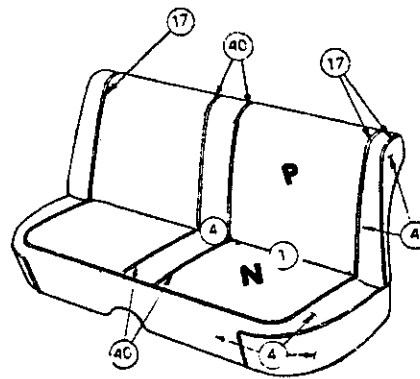
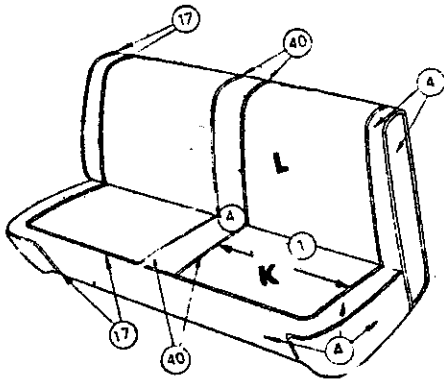
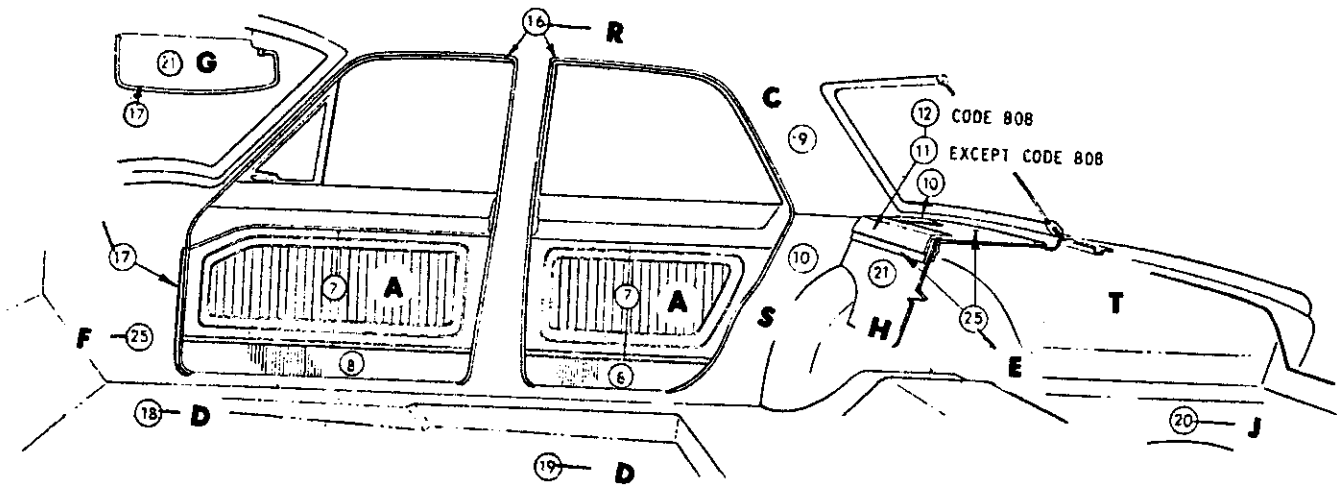

DISTRIBUTION OF MATERIAL

- 1 BODY CLOTH I
- 4 IMITATION LEATHER 32-CH-22
- 5 IMITATION LEATHER 34-DA-22
- 7 IMITATION LEATHER 012-L-22
- 8 IMITATION LEATHER 012A-L-22
- 9 IMITATION LEATHER 17-C-81 OPT 15, 5-C-81
- 10 IMITATION LEATHER 19-C-22
- 11 IMITATION LEATHER 28-AM-22
- 12 IMITATION LEATHER 32A-CH-22
- 16 LACE
- 17 EXTRUDED VINYL
- 18 FLOOR COVERING-FRONT-RUBBER
- 19 FLOOR COVERING-REAR-RUBBER
- 20 FLOOR COVERING-LUGG. COMPT, PRINTED JUT
- 21 EMBOSSED CARDBOARD
- 25 HARDBOARD
- 30 PLASTIC
- 31 PAINT
- 32 METAL
- 33 MOULDING
- 36 MYLAR
- 38 MOULDED RESIN
- 39 PLASTISOL
- 40 EXTRUDED FINYL MYLAR INSERT

Distribution Drawing Legend Page Appears Following Illustration Section

Codes 801, 803, 805, 808

TLL-411

1963 DODGE TL1-L 4 DOOR SEDAN  
CLOTH & IMITATION LEATHER COMBINATION

1963 DODGE - T SERIES

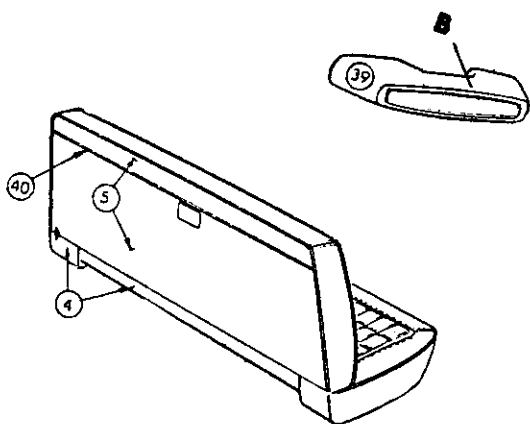
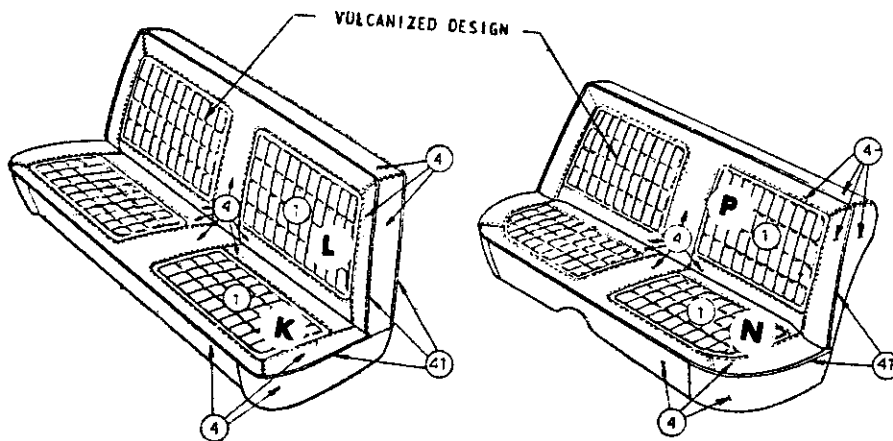
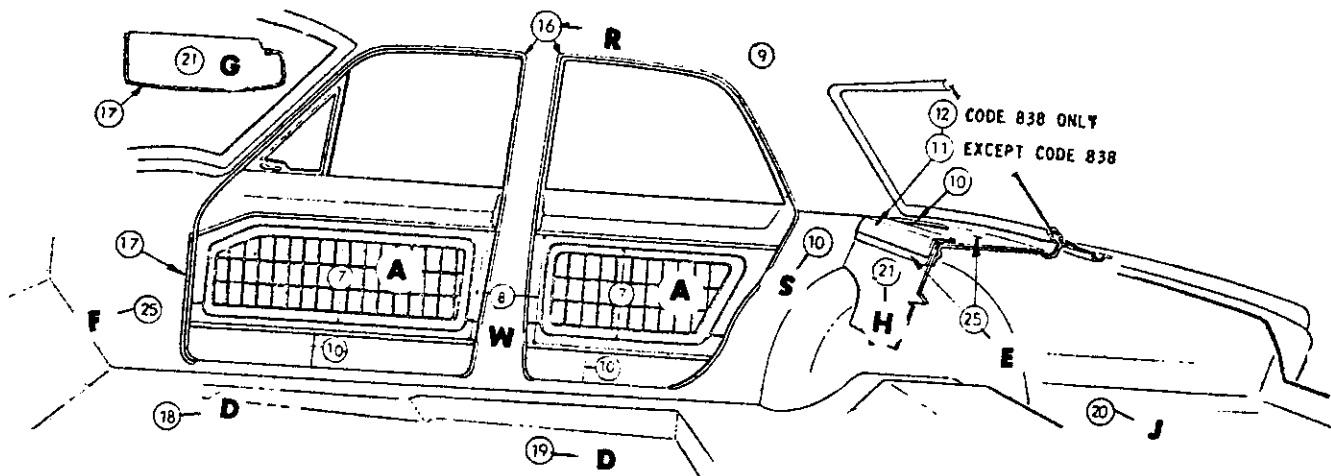

DISTRIBUTING OF MATERIAL

- 1 BODY CLOTH I
- 4 IMITATION LEATHER 32-CH-22
- 5 IMITATION LEATHER 34-DA-22
- 7 IMITATION LEATHER 18-DN-22
- 8 IMITATION LEATHER 012-L-22
- 9 IMITATION LEATHER 17-C-81 OPT 15, 5-C-81
- 10 IMITATION LEATHER 19-C-22
- 11 IMITATION LEATHER 28-AM-22
- 12 IMITATION LEATHER 32A-CH-22
- 16 LACE
- 17 EXTRUDED VINYL
- 18 FLOOR COVERING-FRONT-CARPET
- 19 FLOOR COVERING-REAR-CARPET
- 20 FLOOR COVERING-LUGG. COMPT. PRINTED JUTE
- 21 EMBOSSED CARDBOARD
- 25 HARDBOARD
- 30 PLASTIC
- 31 PAINT
- 32 METAL
- 33 MOULDING
- 36 MYLAR
- 38 MOULDED RESIN
- 39 PLASTISOL
- 40 EXTRUDED VINYL NO. 2
- 41 EXTRUDED VINYL NO. 1

Distribution Drawing Legend Page Appears Following Illustration Section

Codes 831, 833, 835, 838

TLH-411

1963 DODGE TL1-H 4 DOOR SEDAN  
CLOTH & IMITATION LEATHER COMBINATION

1963 DODGE - T SERIES

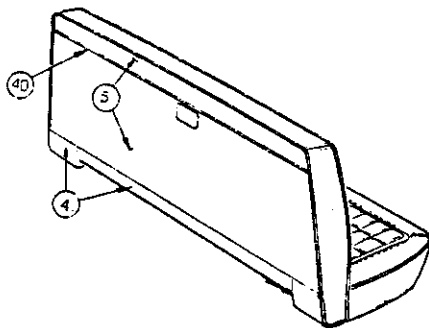
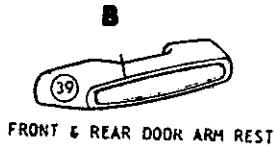
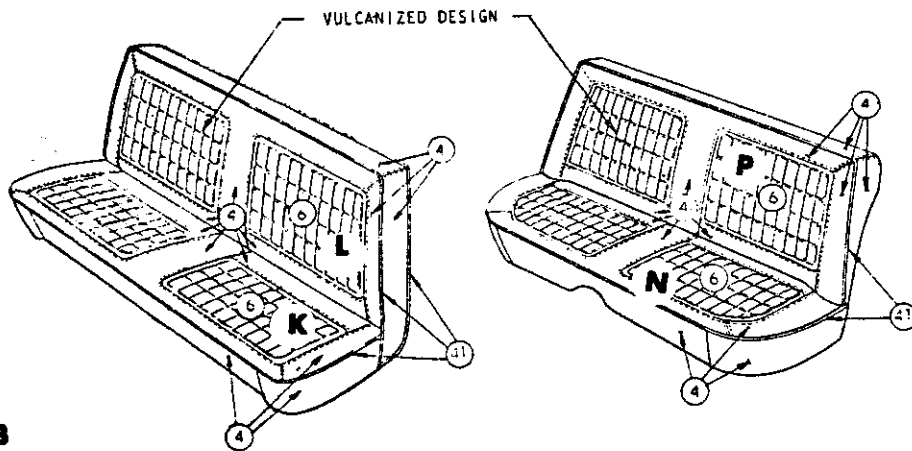
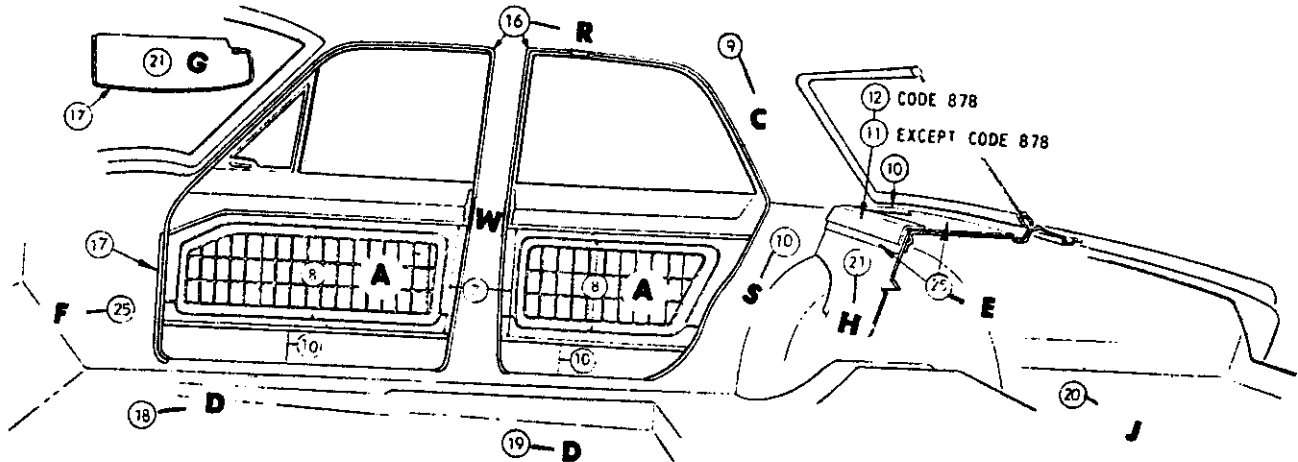

DISTRIBUTION OF MATERIAL

4	IMITATION LEATHER	32-CH-22
5	IMITATION LEATHER	34-DA-22
6	IMITATION LEATHER	29-DP-77
7	IMITATION LEATHER	012-L-22
8	IMITATION LEATHER	18-DN-22
9	IMITATION LEATHER	17-C-81 OPT 15, 5-C-81
10	IMITATION LEATHER	19-C-22
11	IMITATION LEATHER	28-AM-22
12	IMITATION LEATHER	32A-CH-22
16	LACE	
17	EXTRUDED VINYL	
18	FLOOR COVERING-FRONT-CARPET	
19	FLOOR COVERING-REAR-CARPET	
20	FLOOR COVERING-LUGG. COMPT, PRINTED JUTE	
21	EMBOSSED CARDBOARD	
25	HARDBOARD	
30	PLASTIC	
31	PAINT	
32	METAL	
33	MOULDING	
36	MYLAR	
38	MOULDED RESIN	
39	PLASTISOL	
40	EXTRUDED VINYL NO. 2	
41	EXTRUDED VINYL NO. 1	

Distribution Drawing Legend Page Appears Following Illustration Section

Codes 871, 873, 875

TLH-414

1963 DODGE TL1-L, H 4 DOOR SEDAN  
IMITATION LEATHER COMBINATION

1963 DODGE - T SERIES

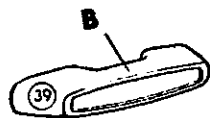
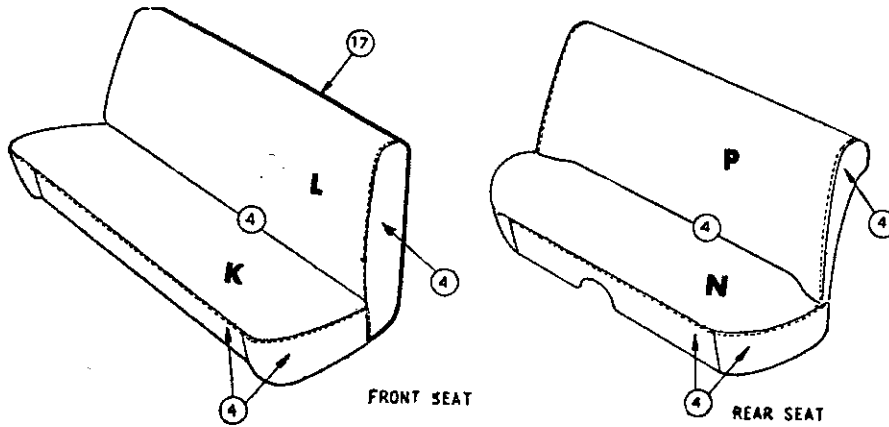
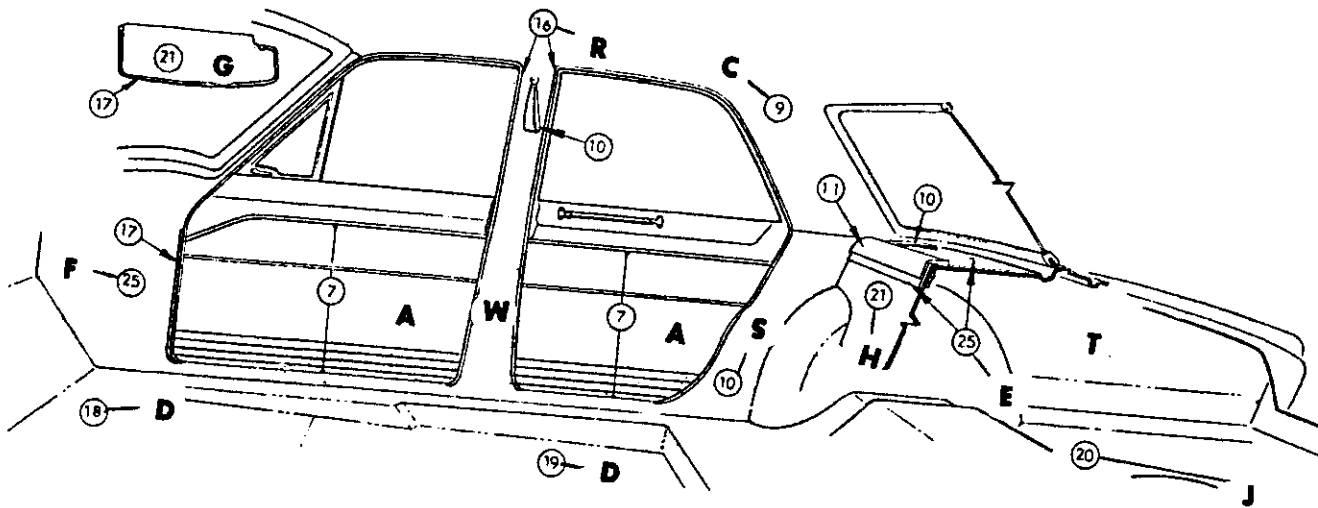

FRONT AND REAR DOOR ARMRESTS

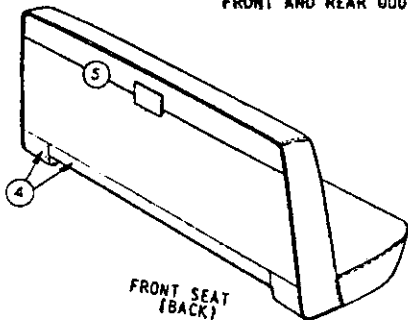

DISTRIBUTION OF MATERIAL

4	IMITATION LEATHER	32-CH-22
5	IMITATION LEATHER	34-DA-22
7	IMITATION LEATHER	21-CM-22
9	IMITATION LEATHER	17-C-81 OPT 15, 5-C-81
10	IMITATION LEATHER	19-C-22
11	IMITATION LEATHER	28-AM-22
16	LACE	
17	EXTRUDED VINYL	
18	FLOOR COVERING-FRONT-RUBBER	
19	FLOOR COVERING-REAR-RUBBER	
20	FLOOR COVERING-LUGG. COMPT. PRINTED JUTE	
21	EMBOSSED CARDBOARD	
25	HARDBOARD	
30	PLASTIC	
31	PAINT	
32	METAL	
33	MOULDING	
36	MYLAR	
38	MOULDED RESIN	
39	PLASTISOL	

Distribution Drawing Legend Page Appears Following Illustration Section

Code 894

TLL-414A

1963 DODGE TL1-L 4 DOOR SEDAN  
IMITATION LEATHER COMBINATION

1963 DODGE - T SERIES

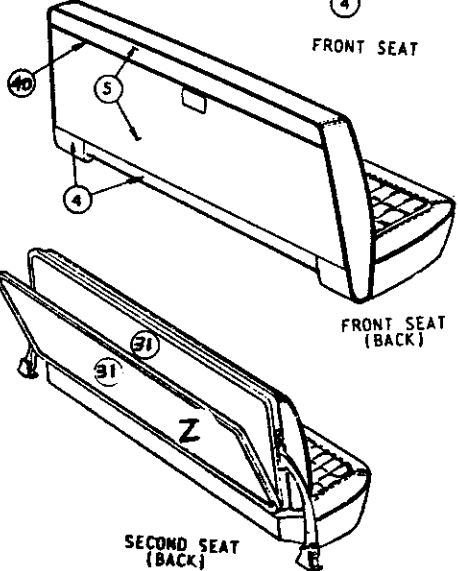
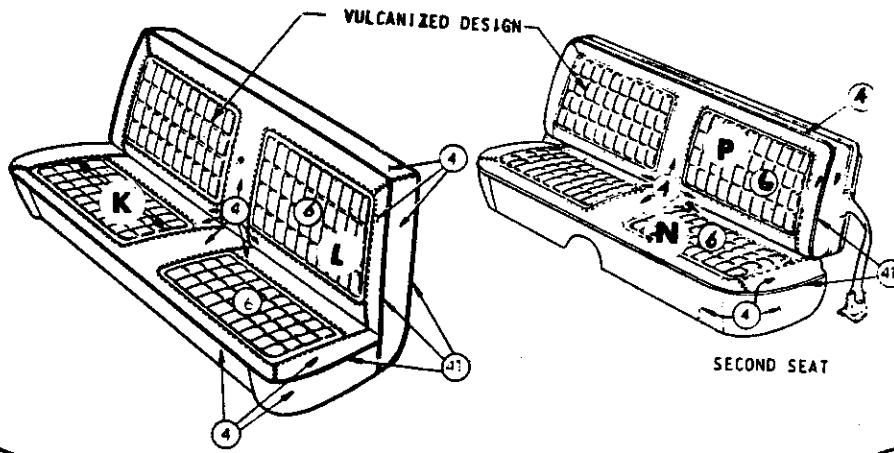
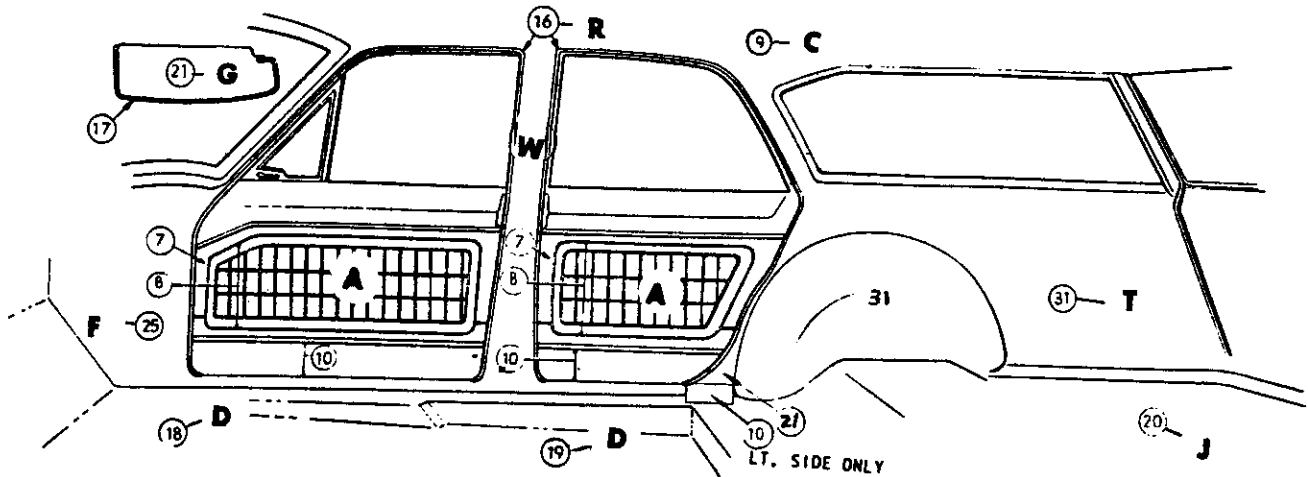

DISTRIBUTION OF MATERIAL

4	IMITATION LEATHER	32-CH-22
5	IMITATION LEATHER	34-DA-22
6	IMITATION LEATHER	29-DP-77
7	IMITATION LEATHER	012-L-22
8	IMITATION LEATHER	18-DN-22
9	IMITATION LEATHER	17-C-81 OPT 15, 5-C-81
10	IMITATION LEATHER	19-C-22
16	LACE	
17	EXTRUDED VINYL	
18	FLOOR COVERING-FRONT-CARPET	
19	FLOOR COVERING-REAR-CARPET	
20	FLOOR COVERING-LUGG. COMPT. RUBBER	
21	EMBOSSED CARDBOARD	
25	HARDBOARD	
30	PLASTIC	
31	PAINT	
32	METAL	
33	MOULDING	
36	MYLAR	
38	MOULDED RESIN	
39	PLASTISOL	
40	EXTRUDED VINYL NO. 2	
41	EXTRUDED VINYL NO. 1	

Distribution Drawing Legend Page Appears Following Illustration Section

Codes 871, 873, 875, 878

TLH-454

1963 DODGE TL1-H 4 DOOR SUBURBAN  
IMITATION LEATHER COMBINATION

1963 DODGE - T SERIES

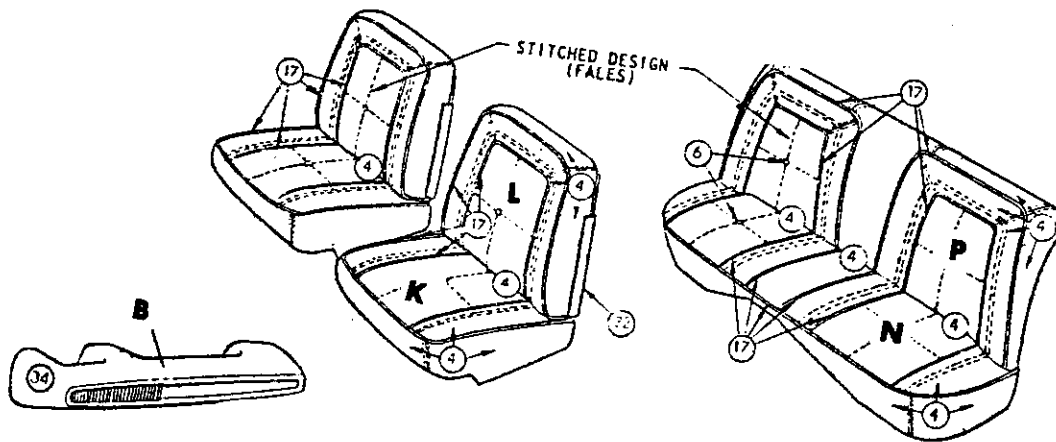
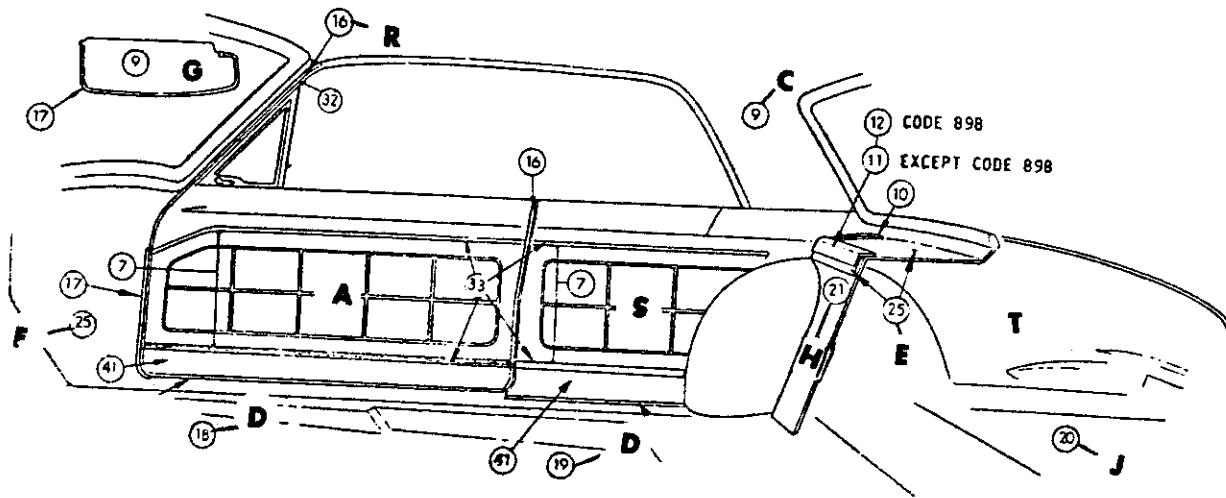

DOOR ARMREST

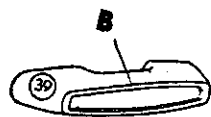

QTR ARM REST

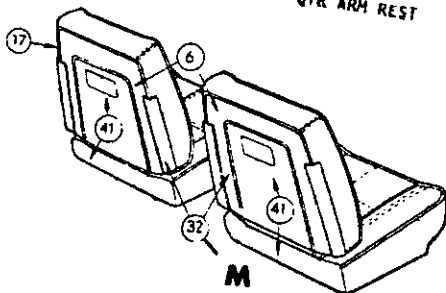

DISTRIBUTION OF MATERIAL

4	IMITATION LEATHER	32-CH-22
6	IMITATION LEATHER	19-C-22
7	IMITATION LEATHER	012-L-22
9	IMITATION LEATHER	17-C-81 OPT 15, 5-C-81
10	IMITATION LEATHER	19A-C-22
11	IMITATION LEATHER	28A-AM-22
12	IMITATION LEATHER	32A-CH-22
16	LACE	
17	EXTRUDED VINYL	
18	FLOOR COVERING-FRONT-CARPET	
19	FLOOR COVERING-REAR-CARPET	
20	FLOOR COVERING-LUGG. PRINTED JUTE	
21	EMBOSSED CARDBOARD	
25	HARDBOARD	
30	PLASTIC	
31	PAINT	
32	METAL	
33	MOULDING	
36	MYLAR	
38	MOULDED RESIN	
39	PLASTISOL	
41	CARPET	

Distribution Drawing Legend Page Appears Following Illustration Section

Codes 891, 893, 895, 898

TLP-234

1963 DODGE TL1-P 2 DOOR HARDTOP  
IMITATION LEATHER



1963 DODGE - T SERIES

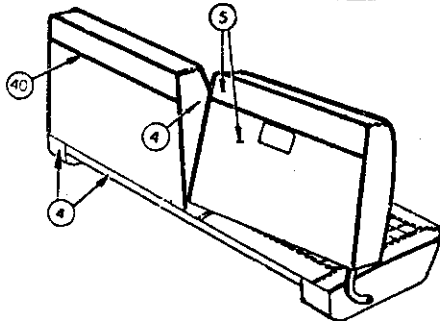
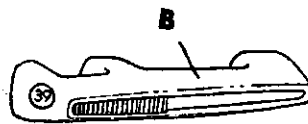
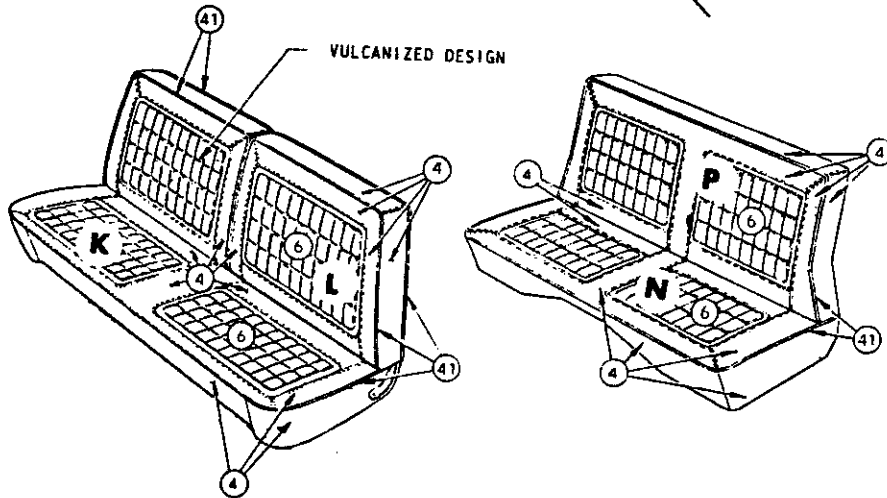
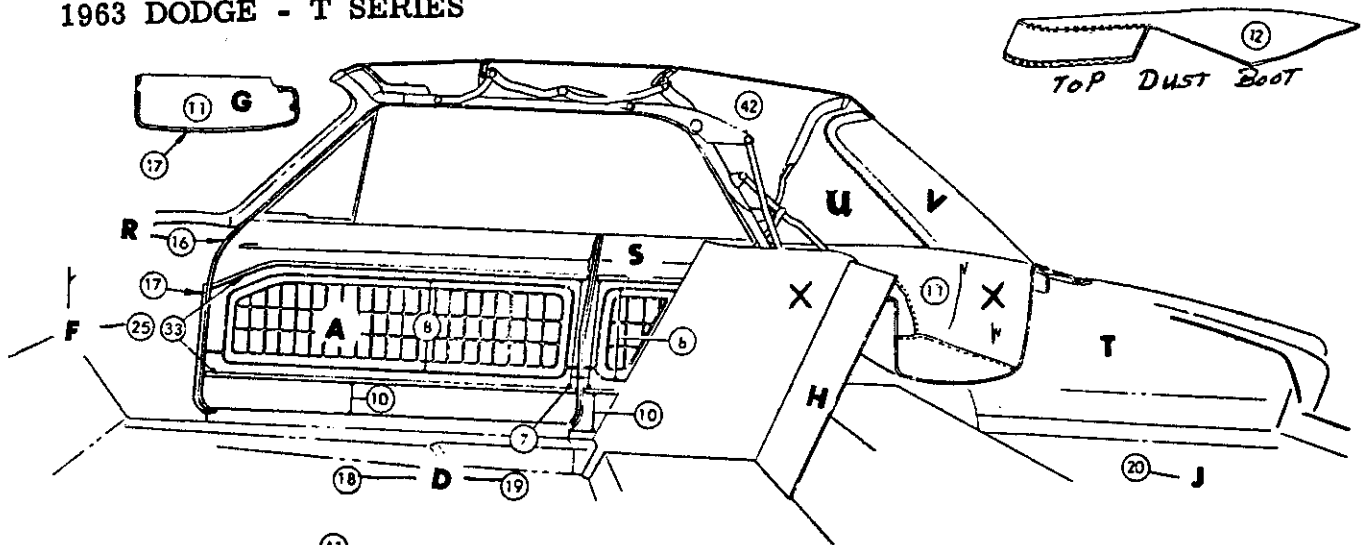

DISTRIBUTION OF MATERIAL

4	IMITATION LEATHER	32-CH-22
5	IMITATION LEATHER	34-DA-22
6	IMITATION LEATHER	29-DP-77
7	IMITATION LEATHER	.012-L-22
8	IMITATION LEATHER	18-DN-22
10	IMITATION LEATHER	19-C-22
11	IMITATION LEATHER	19A-C-22
12	IMITATION LEATHER	28-AM-22
16	LACE	
17	EXTRUDED VINYL	
18	FLOOR COVERING-FRONT-CARPET	
19	FLOOR COVERING-REAR-CARPET	
20	FLOOR COVERING-LUGG. PRINTED JUTE	
21	EMBOSSED CARDBOARD	
25	HARDBOARD	
26	FELT	
30	PLASTIC	
31	PAINT	
32	METAL	
33	MOULDING	
36	MYLAR	
38	MOULDED RESIN	
39	PLASTISOL	
40	EXTRUDED VINYL NO. 2	
41	EXTRUDED VINYL NO. 1	
42	TOP MATERIAL	

Distribution Drawing Legend Page Appears Following Illustration Section

Codes 871, 873, 875, 878

TLH-274

1963 DODGE TL1-H CONVERTIBLE COUPE  
IMITATION LEATHER

1963 DODGE - T SERIES

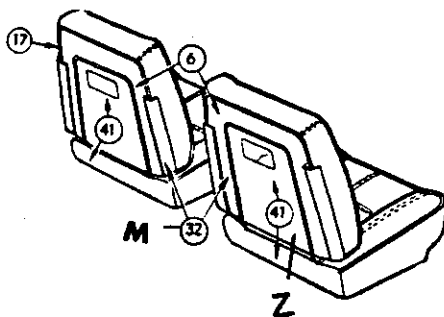
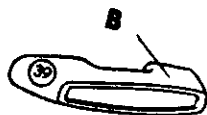
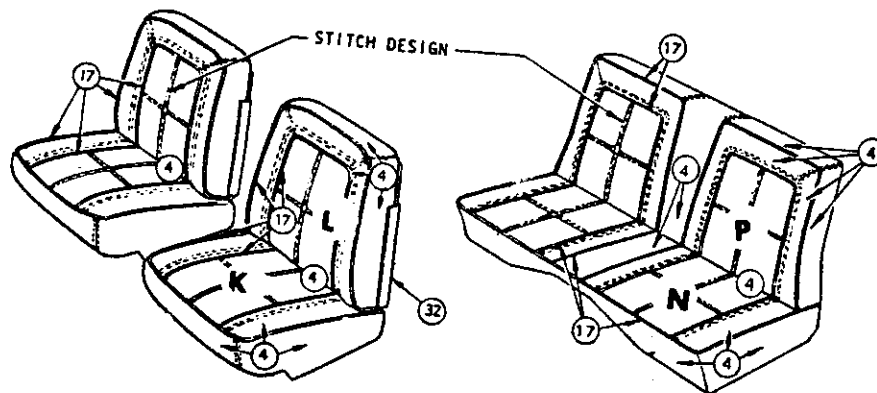
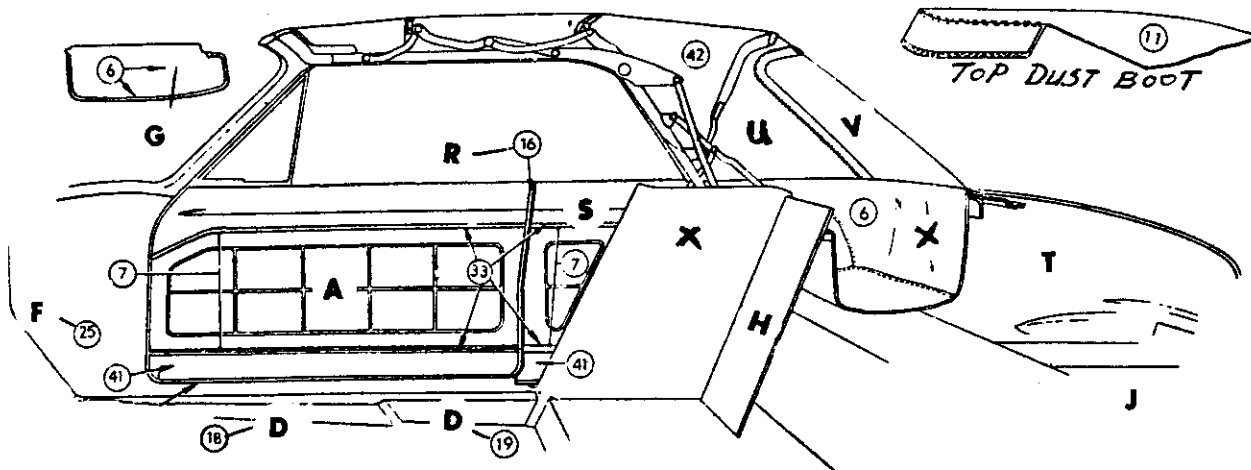

DISTRIBUTION OF MATERIAL

4	IMITATION LEATHER	32-CH-22
6	IMITATION LEATHER	19-C-22
7	IMITATION LEATHER	.012-L-22
9	IMITATION LEATHER	12-Y-71
10	IMITATION LEATHER	19A-C-22
11	IMITATION LEATHER	28-AM-22
16	LACE	
17	EXTRUDED VINYL	
18	FLOOR COVERING-FRONT-CARPET	
19	FLOOR COVERING-REAR-CARPET	
20	FLOOR COVERING-LUGG. PRINTED JUTE	
21	EMBOSSED CARDBOARD	
25	HARDBOARD	
26	FELT	
30	PLASTIC	
31	PAINT	
32	METAL	
33	MOULDING	
36	MYLAR	
38	MOULDED RESIN	
39	PLASTISOL	
41	CARPET	
42	TOP MATERIAL	

Distribution Drawing Legend Page Appears Following Illustration Section

Codes 891, 893, 895, 898

TLP-274

1963 DODGE TL1-P CONVERTIBLE COUPE  
IMITATION LEATHER

1963 DODGE - T SERIES

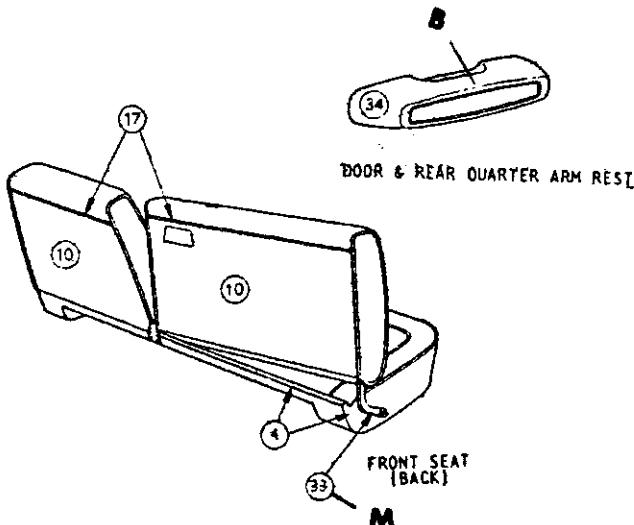
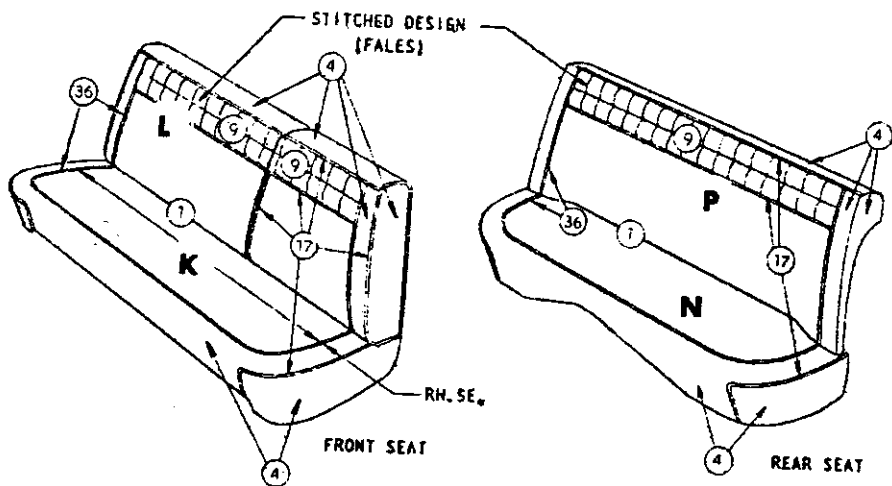
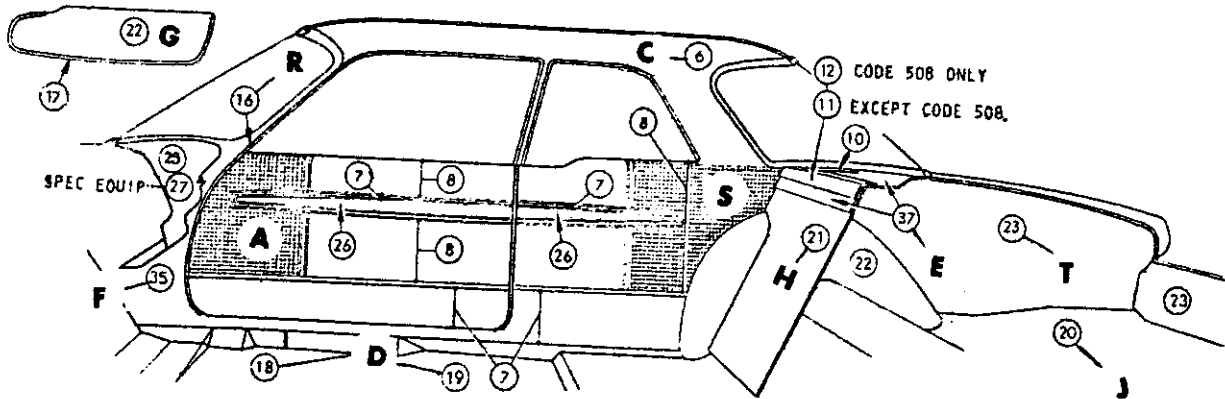

DISTRIBUTION OF MATERIAL

- 1 BODY CLOTH I
- 4 IMITATION LEATHER 28-AM-22
- 6 IMITATION LEATHER 17-C-81 OPT 15, 5-C-81
- 7 IMITATION LEATHER 18-DN-22
- 8 IMITATION LEATHER 19-DJ-22
- 9 IMITATION LEATHER 28A-AM-22
- 10 IMITATION LEATHER 19A-C-22
- 11 IMITATION LEATHER 28B-AM-22
- 12 IMITATION LEATHER 32-CH-22
- 16 LACE
- 17 EXTRUDED VINYL
- 18 FLOOR COVERING-FRONT-RUBBER
- 19 FLOOR COVERING-REAR-RUBBER
- 20 FLOOR COVERING-LUGG. COMPT. RUBBER
- 21 CARDBOARD
- 22 EMBOSSSED CARDBOARD
- 23 PAINT
- 24 METAL
- 25 MOULDING
- 26 MYLAR
- 27 MOULDED RESIN
- 28 MOULDED RUBBER
- 29 MOULDED VINYL
- 32 CARPET
- 33 PLASTIC
- 34 PLASTISOL
- 35 POLYETHYLENE
- 36 EXTRUDED VINYL-MYLAR FILLER
- 37 HARDBOARD

Distribution Drawing Legend Page Appears Following Illustration Section

Codes 501, 503, 505, 508

TDL-211

1963 DODGE TD1 & 2-L 2 DOOR SEDAN  
CLOTH & IMITATION LEATHER COMBINATION

1963 DODGE - T SERIES

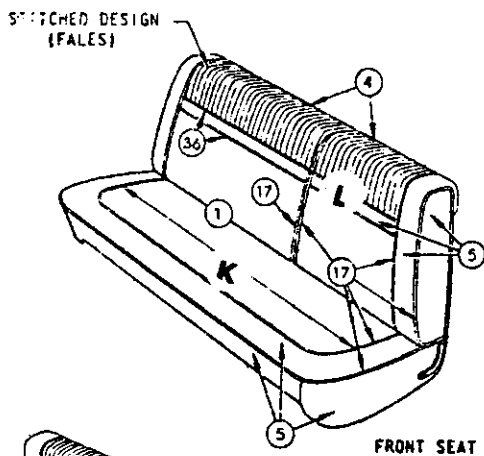
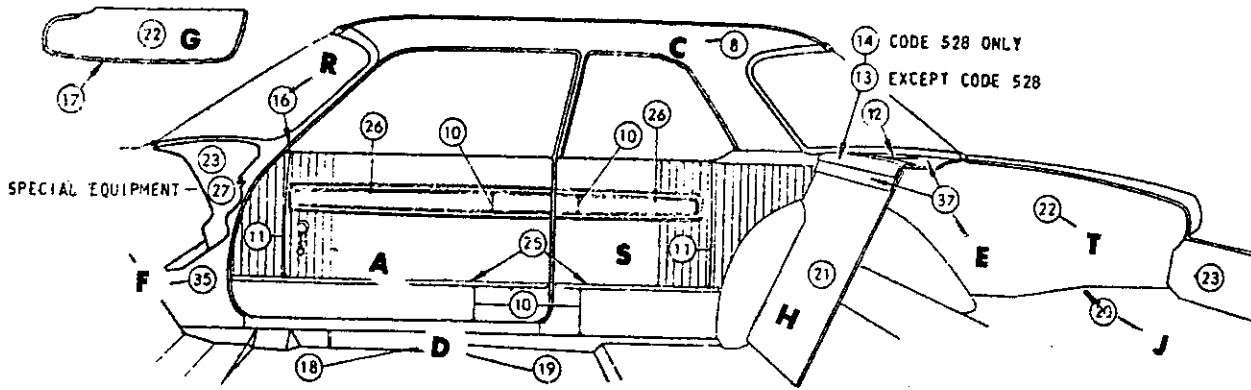

FRONT SEAT

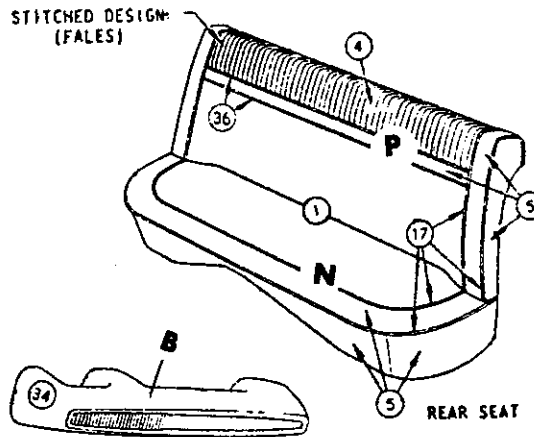

REAR SEAT

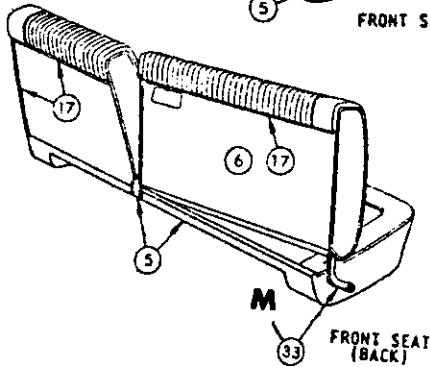

FRONT SEAT (BACK)

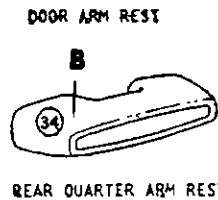

DOOR ARM REST

REAR QUARTER ARM REST

DISTRIBUTION OF MATERIAL

1	BODY CLOTH	1
4	IMITATION LEATHER	28-AM-22
5	IMITATION LEATHER	28A-AM-22
6	IMITATION LEATHER	19-C-22
8	IMITATION LEATHER	17-C-81 OPT 15, 5-C-81
10	IMITATION LEATHER	21-CM-22
11	IMITATION LEATHER	19-DJ-22
12	IMITATION LEATHER	19B-C-22
13	IMITATION LEATHER	28B-AM-22
14	IMITATION LEATHER	32-CH-22
16	LACE	
17	EXTRUDED VINYL	
18	FLOOR COVERING-FRONT-CARPET	
19	FLOOR COVERING-REAR-CARPET	
20	FLOOR COVERING-LUGG. COMPT, RUBBER	
21	CARDBOARD	
22	EMBOSSED CARDBOARD	
23	PAINT	
24	METAL	
25	MOULDING	
26	MYLAR	
27	MOULDED RESIN	
28	MOULDED RUBBER	
29	MOULDED VINYL	
32	CARPET	
33	PLASTIC	
34	PLASTISOL	
35	POLYETHYLENE	
36	EXTRUDED VINYL-MYLAR FILLER	
37	CARDBOARD	

Distribution Drawing Legend Page Appears Following Illustration Section

Codes 521, 523, 525, 526, 528

TDM-211

1963 DODGE TD1 & 2-M 2 DOOR SEDAN  
CLOTH & IMITATION LEATHER COMBINATION

1963 DODGE - T SERIES

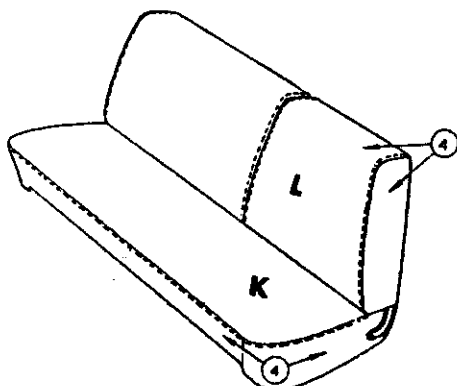
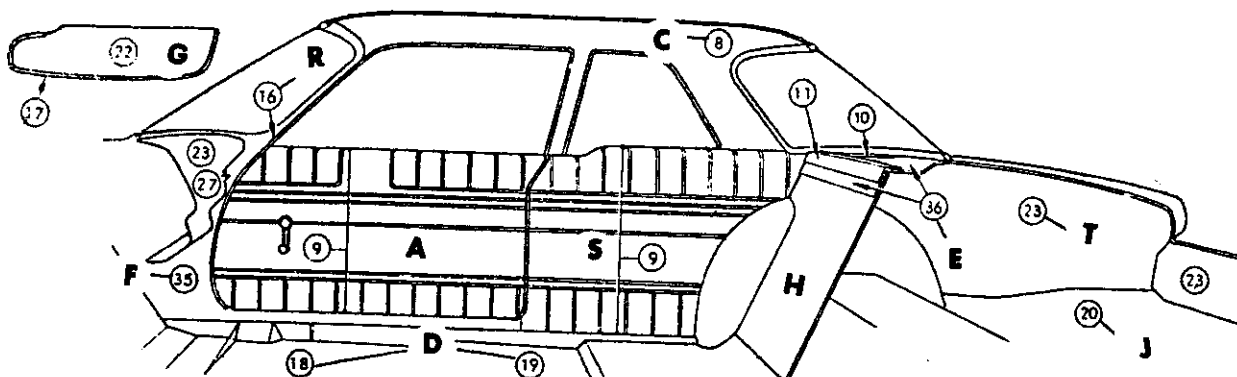

FRONT SEAT

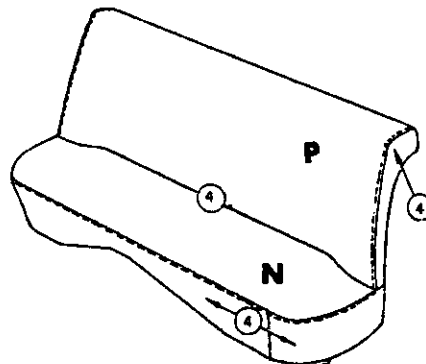

REAR SEAT

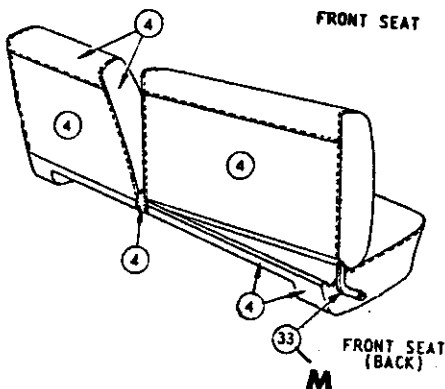

FRONT SEAT (BACK)

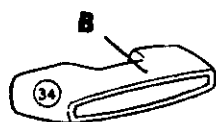

FRONT DOOR ARM RESTS

DISTRIBUTION OF MATERIAL

- 4 IMITATION LEATHER 37-CX-22
- 8 IMITATION LEATHER 17-C-81 OPT 15, 5-C-81
- 9 IMITATION LEATHER 19-DJ-22
- 10 IMITATION LEATHER 19A-C-22
- 11 IMITATION LEATHER 28-AM-22
- 16 LACE
- 17 EXTRUDED VINYL
- 18 FLOOR COVERING-FRONT-RUBBER
- 19 FLOOR COVERING-REAR-RUBBER
- 20 FLOOR COVERING-LUGG. COMPT, RUBBER
- 23 PAINT
- 24 METAL
- 25 MOULDING
- 26 MYLAR
- 27 MOULDED RESIN
- 28 MOULDED RUBBER
- 29 MOULDED VINYL
- 32 CARPET
- 33 PLASTIC
- 34 PLASTISOL
- 35 POLYETHLENE
- 36 HARDBOARD

Distribution Drawing Legend Page Appears Following Illustration Section

Code 694

TDL-214A

1963 DODGE TD1 & 2-L 2 DOOR SEDAN  
IMITATION LEATHER

1963 DODGE - T SERIES

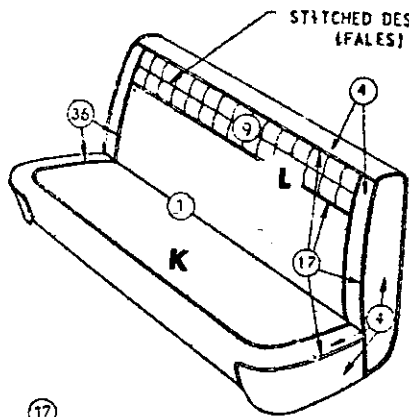
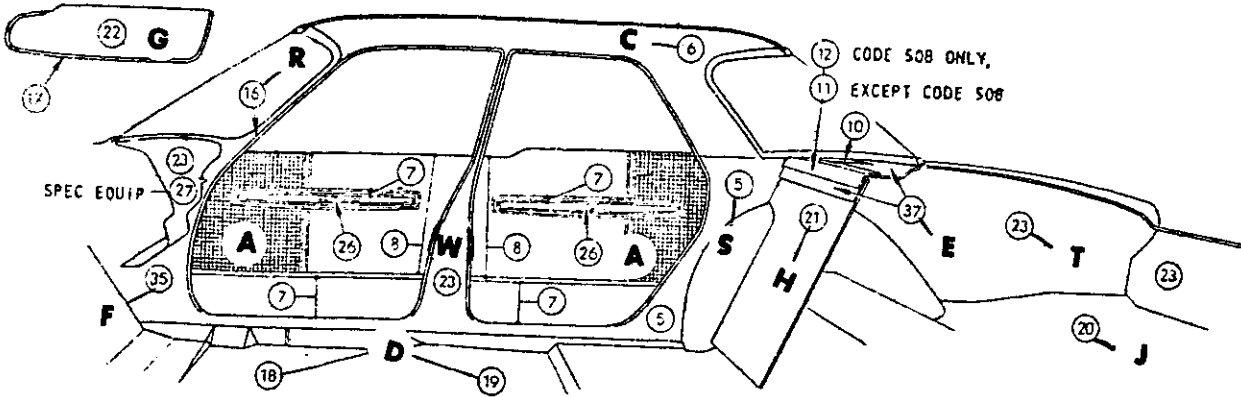

FRONT SEAT

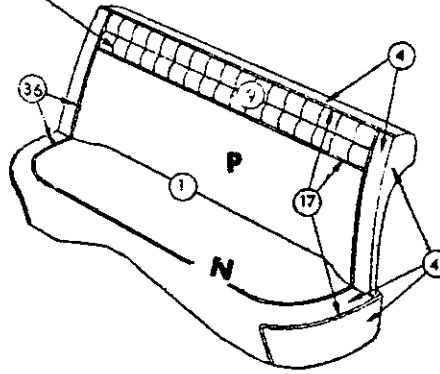

REAR SEAT

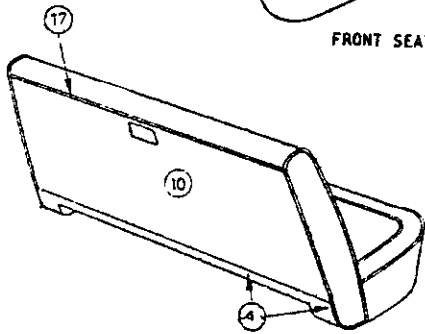

FRONT SEAT (BACK)

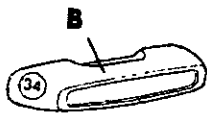

FRONT & REAR DOOR ARM REST

DISTRIBUTION OF MATERIAL

- |    |                                    |                        |
|----|------------------------------------|------------------------|
| 1  | BODY CLOTH                         | I                      |
| 4  | IMITATION LEATHER                  | 28-AM-22               |
| 5  | IMITATION LEATHER                  | 19-C-22                |
| 6  | IMITATION LEATHER                  | 17-C-81-OPT 15, 5-C-81 |
| 7  | IMITATION LEATHER                  | 18-DN-22               |
| 8  | IMITATION LEATHER                  | 19-DJ-22               |
| 9  | IMITATION LEATHER                  | 28A-AM-22              |
| 10 | IMITATION LEATHER                  | 19A-C-22               |
| 11 | IMITATION LEATHER                  | 28B-AM-22              |
| 12 | IMITATION LEATHER                  | 32-CH-22               |
| 16 | LACE                               |                        |
| 17 | EXTRUDED VINYL                     |                        |
| 18 | FLOOR COVERING-FRONT-RUBBER        |                        |
| 19 | FLOOR COVERING-REAR-RUBBER         |                        |
| 20 | FLOOR COVERING-LUGG, COMPT. RUBBER |                        |
| 21 | CARDBOARD                          |                        |
| 22 | EMBOSSED CARDBOARD                 |                        |
| 23 | PAIN                               |                        |
| 24 | METAL                              |                        |
| 25 | MOULDING                           |                        |
| 26 | MYLAR                              |                        |
| 27 | MOULDED RESIN                      |                        |
| 28 | MOULDED RUBBER                     |                        |
| 29 | MOULDED VINYL                      |                        |
| 32 | CARPET                             |                        |
| 33 | PLASTIC                            |                        |
| 34 | PLASTISOL                          |                        |
| 35 | POLYETHYLENE                       |                        |
| 36 | EXTRUDED VINYL-MYLAR FILLER        |                        |
| 37 | HARDBOARD                          |                        |

Distribution Drawing Legend Page Appears Following Illustration Section

Codes 501, 503, 505, 508

TDL-411

1963 DODGE TD1 & 2-L 4 DOOR SEDAN  
CLOTH & IMITATION LEATHER COMBINATION

1963 DODGE - T SERIES

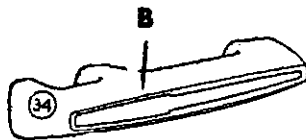
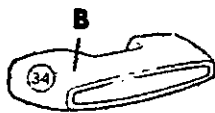
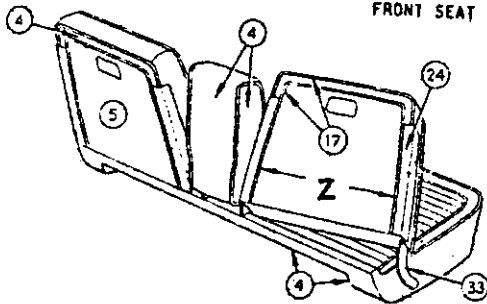
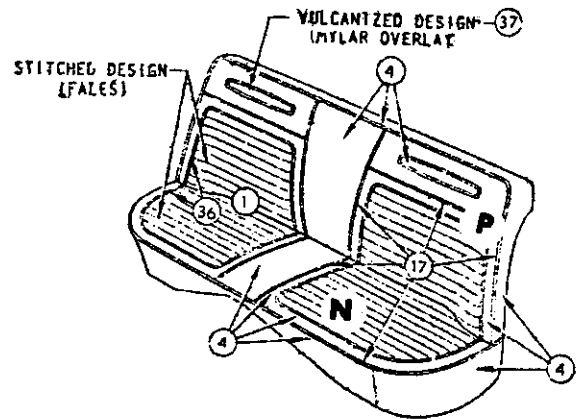
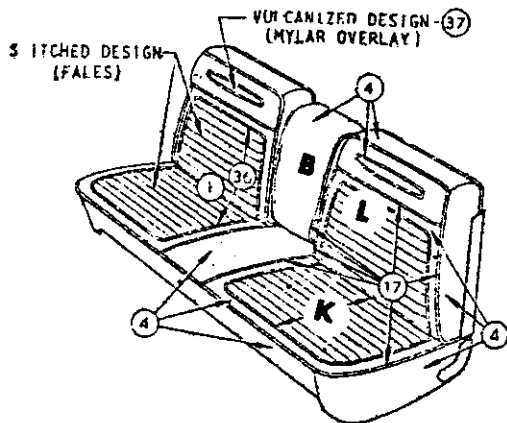
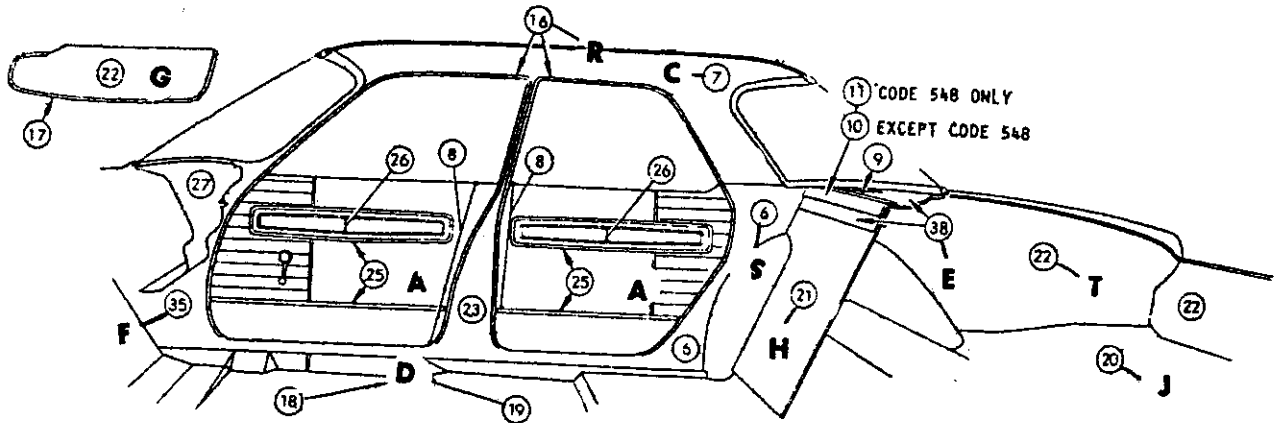

DISTRIBUTION OF MATERIAL

- 1 BODY CLOTH 1
- 4 IMITATION LEATHER 28-AM-22
- 5 IMITATION LEATHER 20-DT-77
- 6 IMITATION LEATHER 19-C-22
- 7 IMITATION LEATHER 17-C-81 OPT 15, 5-C-81
- 8 IMITATION LEATHER 19-DJ-22
- 9 IMITATION LEATHER 19A-C-22
- 10 IMITATION LEATHER 28A-AM-22
- 11 IMITATION LEATHER 32-CH-22
- 16 LACE
- 17 EXTRUDED VINYL
- 18 FLOOR COVERING-FRONT-CARPET
- 19 FLOOR COVERING-REAR-CARPET
- 20 FLOOR COVERING-LUGG. COMPT. RUBBER
- 21 CARDBOARD
- 22 EMBOSSED CARDBOARD
- 23 PAINT
- 24 METAL
- 25 MOULDING
- 26 MYLAR NO. 1
- 27 MOULDED RESIN
- 28 MOULDED RUBBER
- 29 MOULDED VINYL
- 32 CARPET
- 33 PLASTIC
- 34 PLASTISOL
- 35 POLYETHYLENE
- 36 EXTRUDED VINYL-MYLAR FILLER
- 37 MYLAR NO. 2
- 38 HARDBOARD

Distribution Drawing Legend Page Appears Following Illustration Section

Codes 521, 523, 525, 526, 528

TDH-411

1963 DODGE TD1 & TD2-H 4 DOOR SEDAN  
CLOTH & IMITATION LEATHER COMBINATION

1963 DODGE - T SERIES

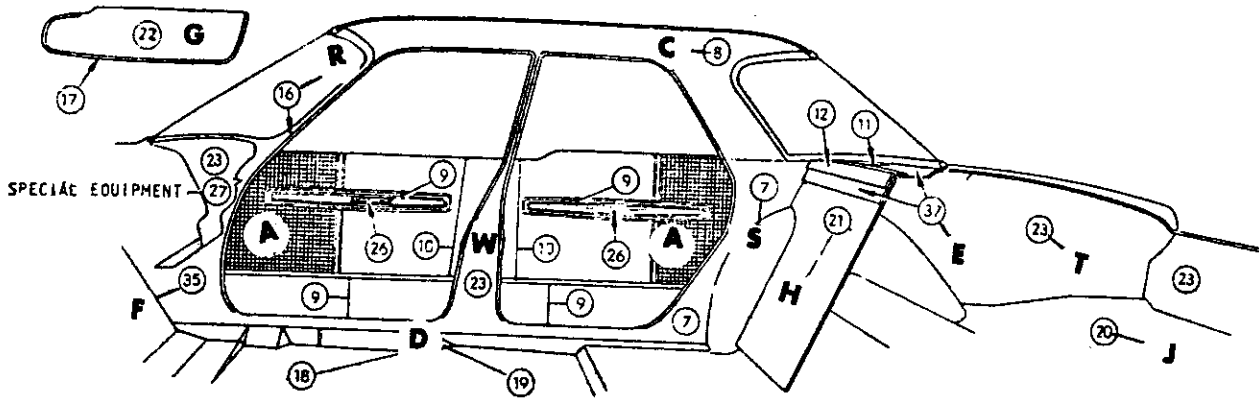

STITCHED DESIGN (FALES)

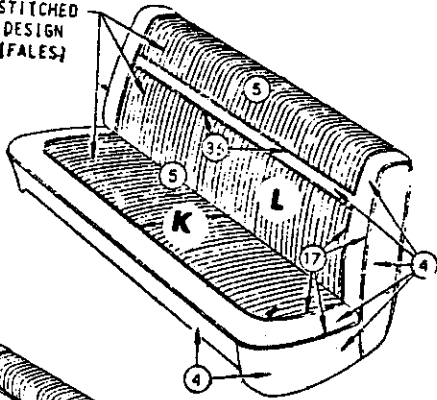

STITCHED DESIGN (FALES)

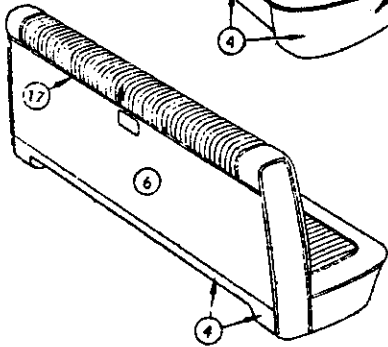
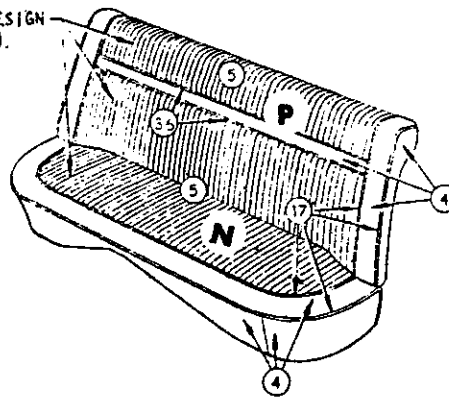

FRONT & REAR DOOR ARM REST

DISTRIBUTION OF MATERIAL

4	IMITATION LEATHER	28-AM-22
5	IMITATION LEATHER	32-DD-74
6	IMITATION LEATHER	19-C-22
7	IMITATION LEATHER	19A-C-22
8	IMITATION LEATHER	17-C-81 OPT. 15, 5-C-81
9	IMITATION LEATHER	18-DN-22
10	IMITATION LEATHER	19-DJ-22
11	IMITATION LEATHER	19B-C-22
12	IMITATION LEATHER	28A-AM-22
16	LACE	
17	EXTRUDED VINYL	
18	FLOOR COVERING-FRONT-RUBBER	
19	FLOOR COVERING-REAR-RUBBER	
20	FLOOR COVERING-LUGG, COMPT. RUBBER	
21	CARDBOARD	
23	PAINT	
24	METAL	
25	MOULDING	
26	MYLAR	
27	MOULDED RESIN	
28	MOULDED RUBBER	
29	MOULDED VINYL	
32	CARPET	
33	PLASTIC	
34	PLASTISOL	
35	POLYETHYLENE	
36	EXTRUDED VINYL-MYLAR FILLER	
37	HARDBOARD	

Distribution Drawing Legend Page Appears Following Illustration Section

Codes 611, 613

TDL-414

1963 DODGE TD1 & 2-L 4 DOOR SEDAN  
IMITATION LEATHER TRIM









1963 DODGE - T SERIES

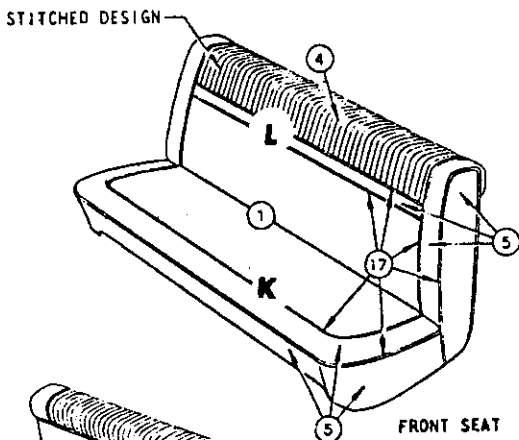
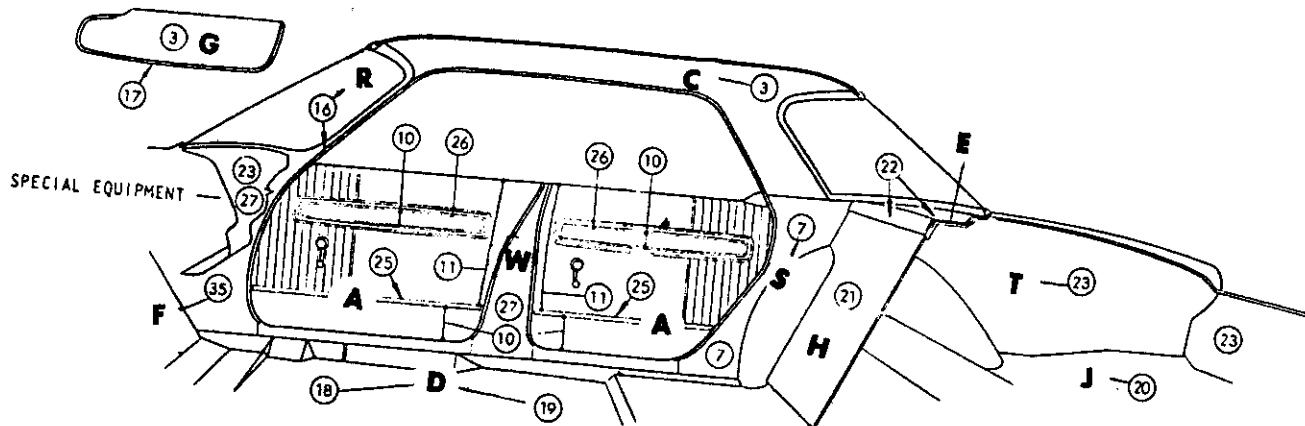

FRONT SEAT

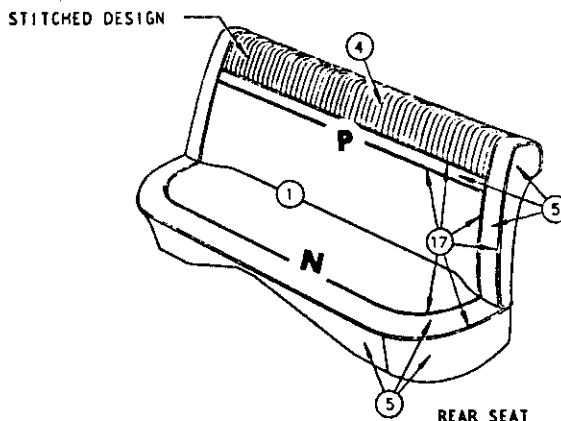

REAR SEAT

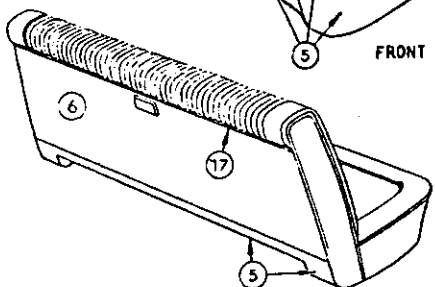

FRONT SEAT (BACK)

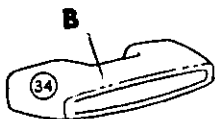

REAR DOOR ARM REST

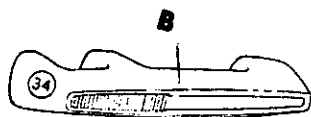

FRONT DOOR ARM REST

DISTRIBUTION OF MATERIAL

1	BODY CLOTH	1	HARDBOARD
3	HEADLINING	28-AM-22	
4	IMITATION LEATHER	28A-AM-22	
5	IMITATION LEATHER	19-C-22	
6	IMITATION LEATHER	19A-C-22	
7	IMITATION LEATHER	21-CM-22	
10	IMITATION LEATHER	19-DJ-22	
11	IMITATION LEATHER		
16	LACE		
17	EXTRUDED VINYL		
18	FLOOR COVERING-FRONT-CARPET		
19	FLOOR COVERING-REAR-CARPET		
20	FLOOR COVERING-LUGG. COMPT. RUBBER		
21	CARDBOARD		
22	EMBOSSED CARDBOARD		
23	PAINT		
24	METAL		
25	MOULDING		
26	MYLAR		
27	MOULDED RESIN		
28	MOULDED RUBBER		
29	MOULDED VINYL		
32	CARPET		
33	PLASTIC		
34	PLASTISOL		
35	POLYETHLENE		

Distribution Drawing Legend Page Appears Following Illustration Section

Codes 521, 523, 525, 526, 528

TDM-431

1963 DODGE TD1 & 2-M SPECIAL 4 DOOR SEDAN  
CLOTH & IMITATION LEATHER COMBINATION

1963 DODGE - T SERIES

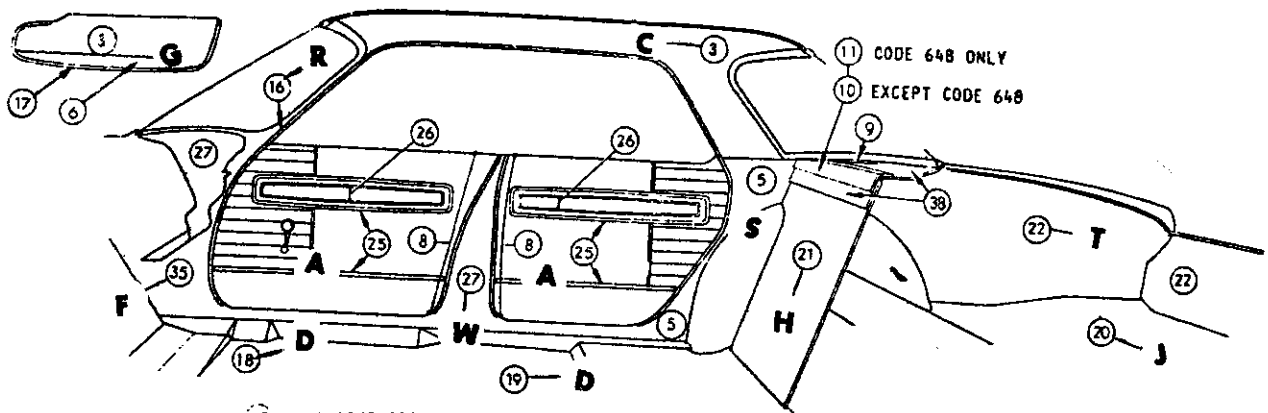

27 VULCANIZED DESIGN (MYLAR OVERLAY)  
STITCHED DESIGN (FALES)

37 VULCANIZED DESIGN (MYLAR OVERLAY)  
STITCHED DESIGN (FALES)

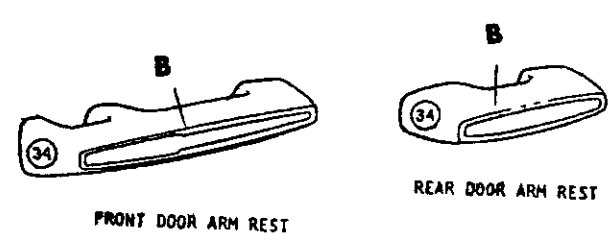
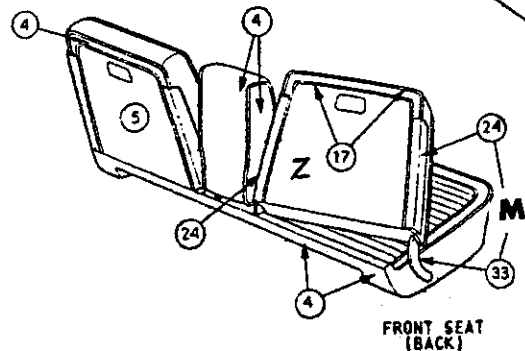
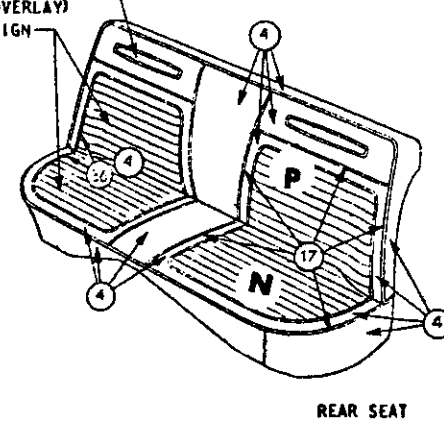
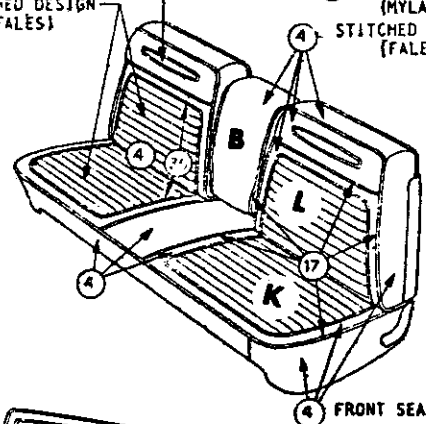

DISTRIBUTION OF MATERIAL

3	HEADLINING	POLYURETHANE
4	IMITATION LEATHER	28-AM-22
5	IMITATION LEATHER	19-C-22
6	IMITATION LEATHER	19A-C-22
8	IMITATION LEATHER	19-DJ-22
9	IMITATION LEATHER	19B-C-22
10	IMITATION LEATHER	28A-AM-22
11	IMITATION LEATHER	32-CH-22
16	LACE	
17	EXTRUDED VINYL	
18	FLOOR COVERING-FRONT-CARPET	
19	FLOOR COVERING-REAR-CARPET	
20	FLOOR COVERING-LUGG. COMPT. RUBBER	
21	CARDBOARD	
23	PAINT	
24	METAL	
25	MOULDING	
26	MYLAR NO. 1	
27	MOULDED RESIN	
28	MOULDED RUBBER	
29	MOULDED VINYL	
30	CARPET	
31	PLASTIC	
32	PLASTIC	
33	PLASTIC	
34	PLASTISOL	
35	POLYETHYLENE	
36	EXTRUDED VINYL-MYLAR FILLER	
37	MYLAR NO. 2	
38	HARDBOARD	

Distribution Drawing Legend Page Appears Following Illustration Section

Codes 641, 643, 645, 648

TDH-434 1963 DODGE TD1 & 2-H SPECIAL 4 DOOR SEDAN  
IMITATION LEATHER COMBINATION

1963 DODGE - T SERIES

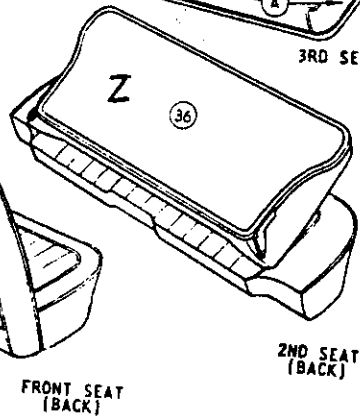
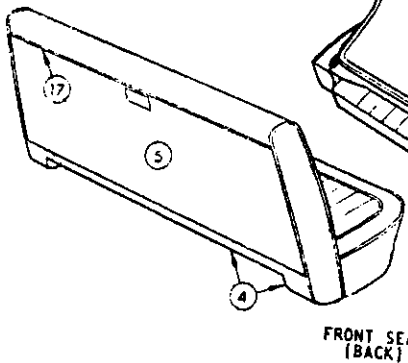
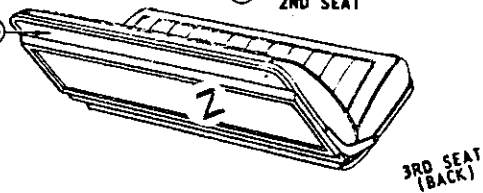
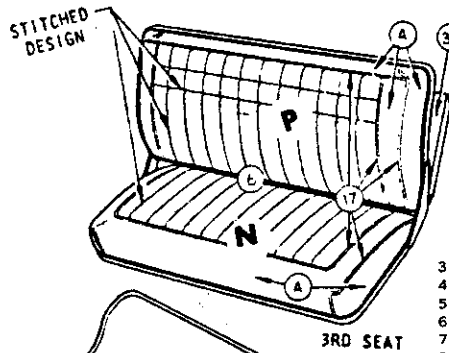
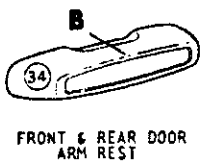
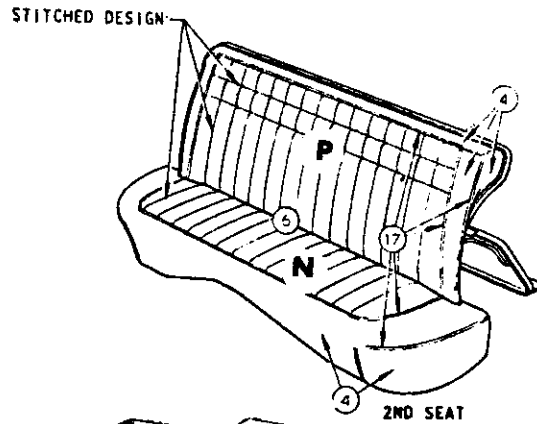
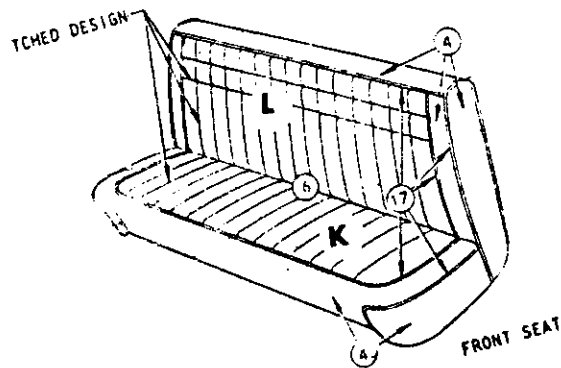
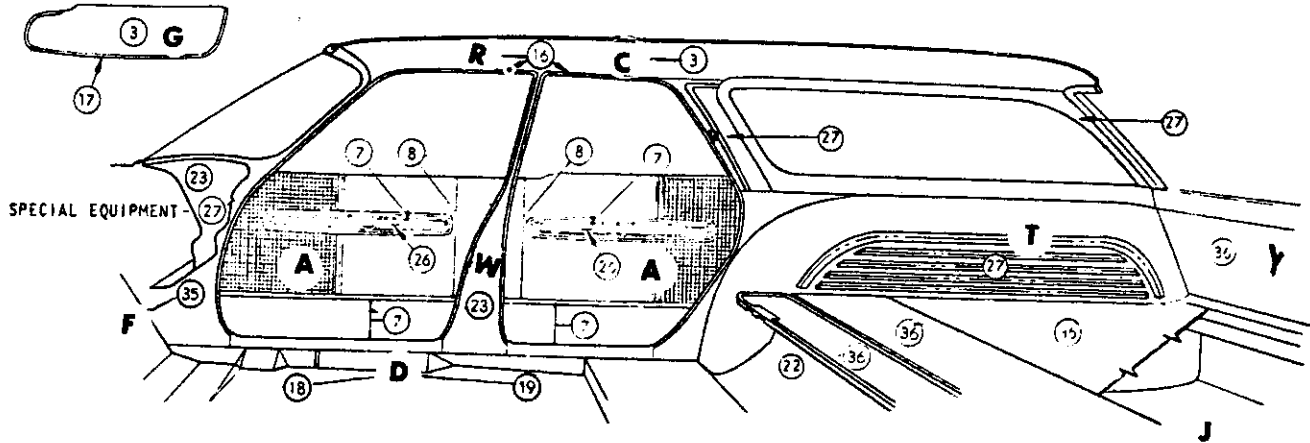

DISTRIBUTION OF MATERIAL

3	HEADLINING	HARDBOARD
4	IMITATION LEATHER	28-AM-22
5	IMITATION LEATHER	19-C-22
6	IMITATION LEATHER	31-DU-80
7	IMITATION LEATHER	18-DN-22
8	IMITATION LEATHER	19-DJ-22
16	LACE	
17	EXTRUDED VINYL	
18	FLOOR COVERING-FRONT-RUBBER	
19	FLOOR COVERING-REAR-RUBBER	
20	FLOOR COVERING-LUGG. COMPT. RUBBER	
22	EMBOSSED CARDBOARD	
23	PAINT	
24	METAL	
25	MOULDING	
26	MYLAR	
27	MOULDED RESIN	
28	MOULDED RUBBER	
29	MOULDED VINYL	
32	CARPET	
33	PLASTIC	
34	PLASTISOL	
35	POLYETHLENE	
36	VINOLEUM	

Distribution Drawing Legend Page Appears Following Illustration Section

Codes 601, 603, 605, 608

TDL-454

1963 DODGE TD1 & 2-L 4 DOOR SUBURBAN  
IMITATION LEATHER COMBINATION TRIM

1963 DODGE - T SERIES

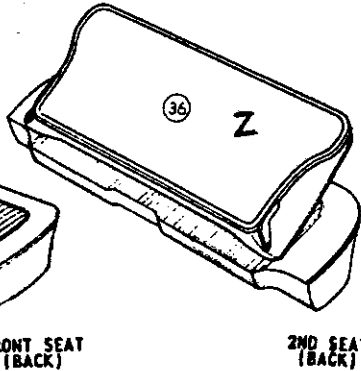
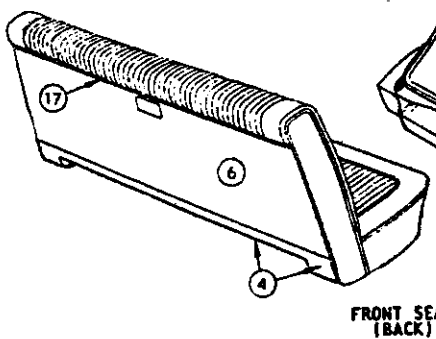
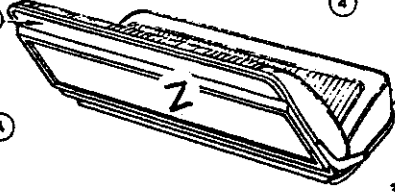
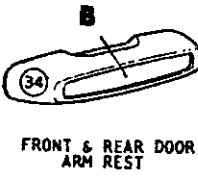
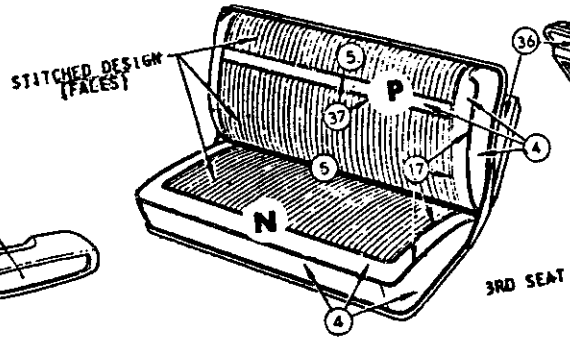
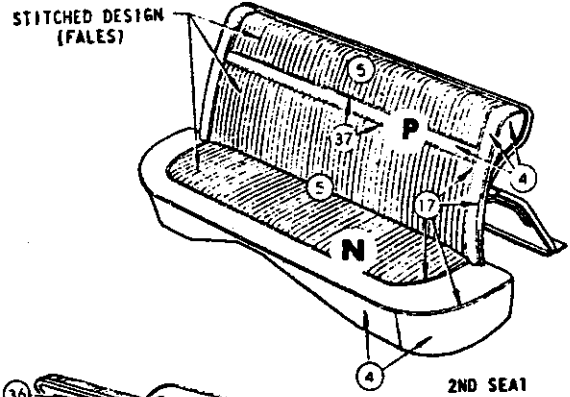
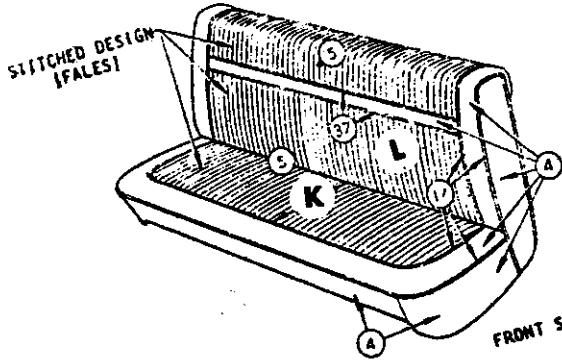
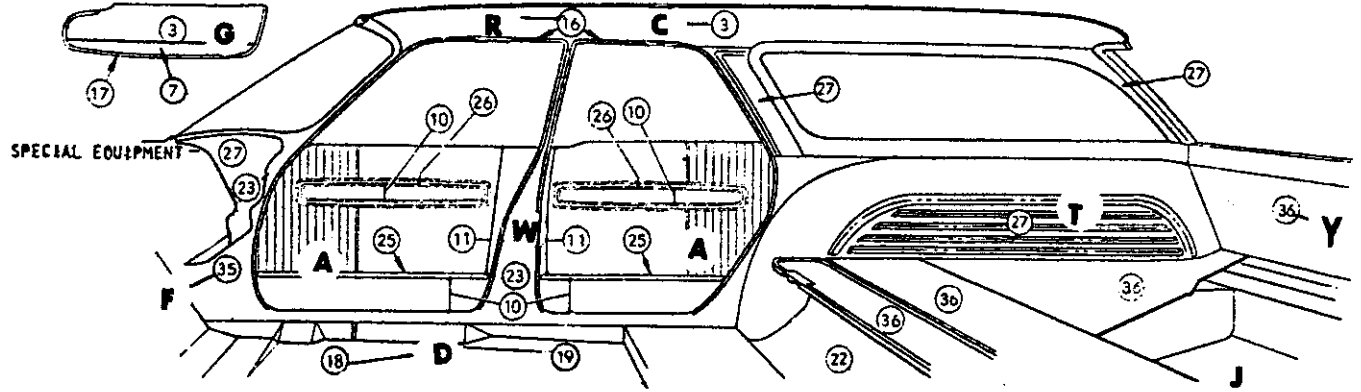

DISTRIBUTION OF MATERIAL

3	HEADLINING	POLYURETHANE
4	IMITATION LEATHER	28-AM-22
5	IMITATION LEATHER	32-DD-74
6	IMITATION LEATHER	19-C-22
7	IMITATION LEATHER	19B-C-22
10	IMITATION LEATHER	21-CM-22
11	IMITATION LEATHER	19-DJ-22
16	LACE	
17	EXTRUDED VINYL	
18	FLOOR COVERING-FRONT-CARPET	
19	FLOOR COVERING-REAR-CARPET	
20	FLOOR COVERING-LUGG. COMPT.	
23	PAINT	
24	METAL	
25	MOULDING	
26	MYLAR	
27	MOULDED RESIN	
28	MOULDED RUBBER	
29	MOULDED VINYL	
32	CARPET	
33	PLASTIC	
34	PLASTISOL	
35	POLYETHLENE	
36	VINOLEUM	
37	EXTRUDED VINYL-MYLAR FILLER	

Distribution Drawing Legend Page Appears Following Illustration Section

Codes 621, 623, 625, 626, 628

TDM-454

1963 DODGE TD1 & TD2-M 4 DOOR SUBURBAN  
IMITATION LEATHER COMBINATION

1963 DODGE - T SERIES

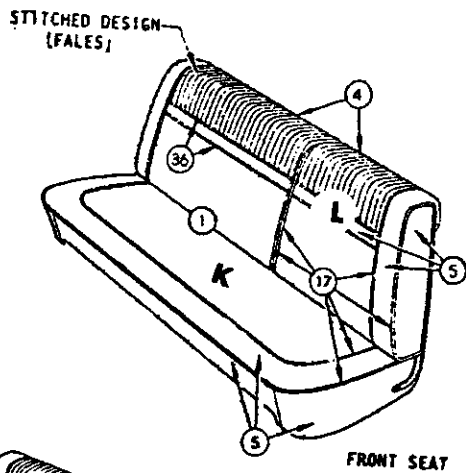
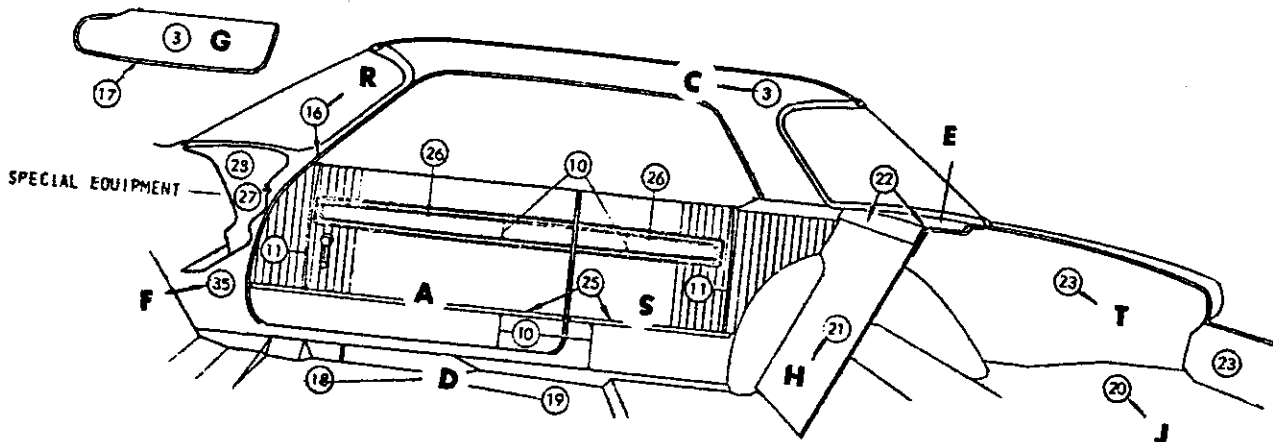

FRONT SEAT

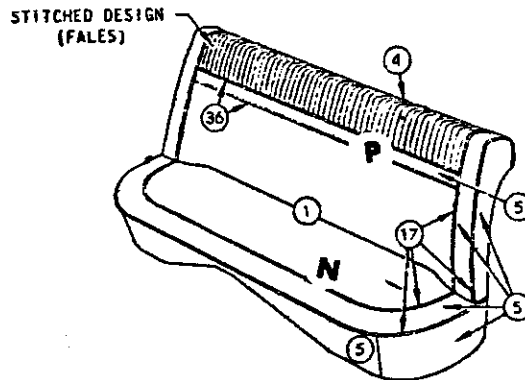

REAR SEAT

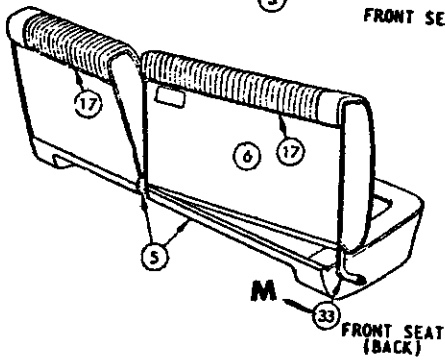

FRONT SEAT (BACK)

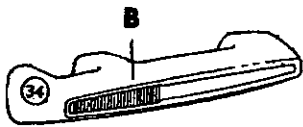

DOOR ARM REST

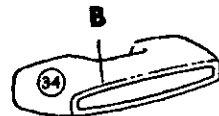

REAR QUARTER ARM REST

DISTRIBUTION OF MATERIAL

1	BODY CLOTH	I
3	HEADLINING	HARDBOARD
4	IMITATION LEATHER	28-AM-22
5	IMITATION LEATHER	28A-AM-22
6	IMITATION LEATHER	19-C-22
10	IMITATION LEATHER	21-CM-22
11	IMITATION LEATHER	19-DJ-22
16	LACE	
17	EXTRUDED VINYL	
18	FLOOR COVERING-FRONT-CARPET	
19	FLOOR COVERING-REAR-CARPET	
20	FLOOR COVERING-LUGG. COMPT. RUBBER	
21	CARDBOARD	
22	EMBOSSED CARDBOARD	
23	PAIN	
24	METAL	
25	MOULDING	
26	MYLAR	
27	MOULDED RESIN	
28	MOULDED RUBBER	
29	MOULDED VINYL	
32	CARPET	
33	PLASTIC	
34	PLASTISOL	
35	POLYETHLENE	
36	EXTRUDED VINYL-MYLAR FILLER	

Distribution Drawing Legend Page Appears Following Illustration Section

Codes 521, 523, 525, 526, 528

TDM-231

1963 DODGE TD1 & 2-L SPECIAL CLUB COUPE  
CLOTH & IMITATION LEATHER COMBINATION



1963 DODGE - T SERIES

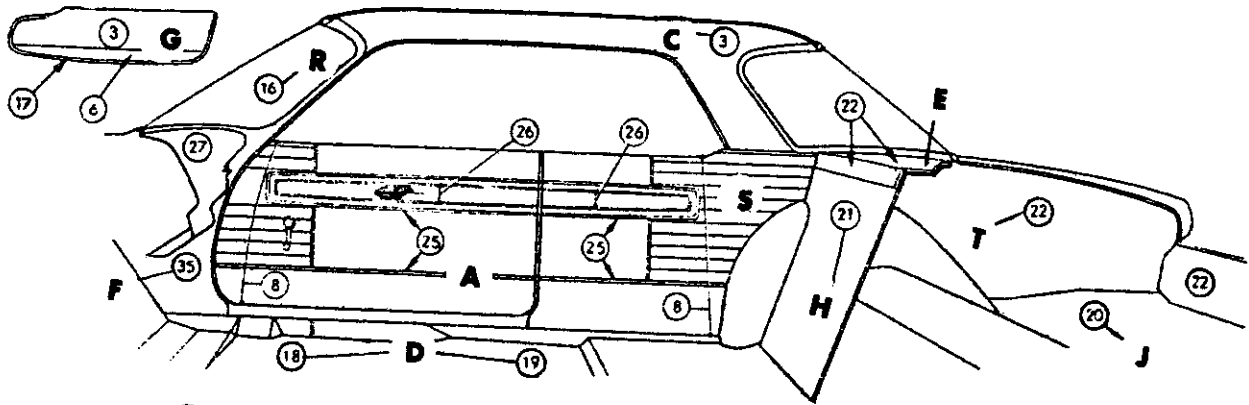

37 VULCANIZED DESIGN (MYLAR OVERLAY) STITCHED DESIGN (FACE)

37 VULCANIZED DESIGN (MYLAR OVERLAY) STITCHED DESIGN (FALES)

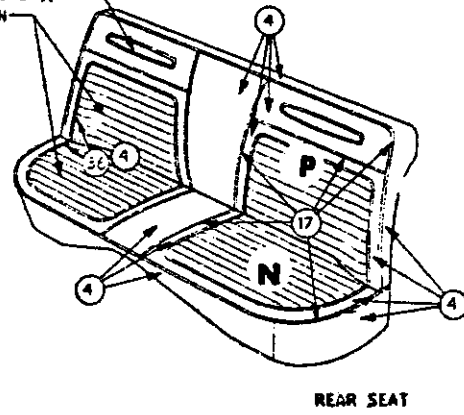
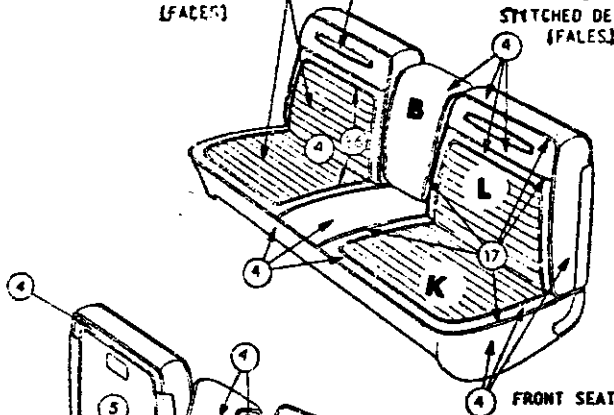

FRONT SEAT

REAR SEAT

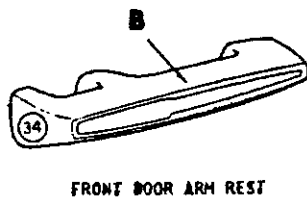

FRONT DOOR ARM REST

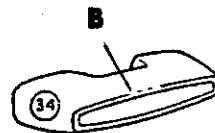

REAR QUARTER ARM REST

DISTRIBUTION OF MATERIAL

- 3 HEADLINING POLYURETHANE
- 4 IMITATION LEATHER 28-AM-22
- 5 IMITATION LEATHER 19-C-22
- 6 IMITATION LEATHER 19A-C-22
- 8 IMITATION LEATHER 19-DJ-22
- 16 LACE
- 17 EXTRUDED VINYL
- 18 FLOOR COVERING-FRONT-CARPET
- 19 FLOOR COVERING-REAR-CARPET
- 20 FLOOR COVERING-LUGG. COMPT. RUBBER
- 21 CARDBOARD
- 22 EMBOSSED CARDBOARD
- 23 PAINT
- 24 METAL
- 25 MOULDING
- 26 MYLAR NO. 1
- 27 MOULDED RESIN
- 28 MOULDED RUBBER
- 29 MOULDED VINYL
- 32 CARPET
- 33 PLASTIC
- 34 PLASTISOL
- 35 POLYETHYLENE
- 36 EXTRUDED VINYL-MYLAR FILLER
- 37 MYLAR NO. 2

Distribution Drawing Legend Page Appears Following Illustration Section

Codes 641, 643, 645, 646, 648

TDH-234

1963 DODGE TD1 & 2-H SPECIAL CLUB COUPE  
IMITATION LEATHER COMBINATION

1963 DODGE - T SERIES

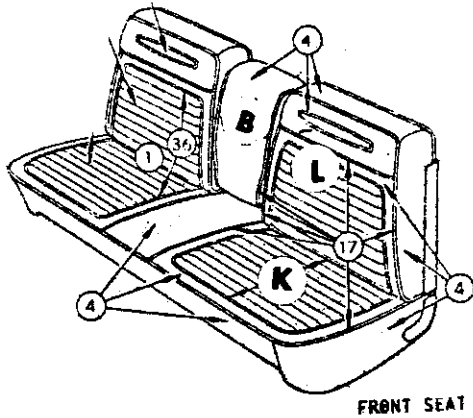
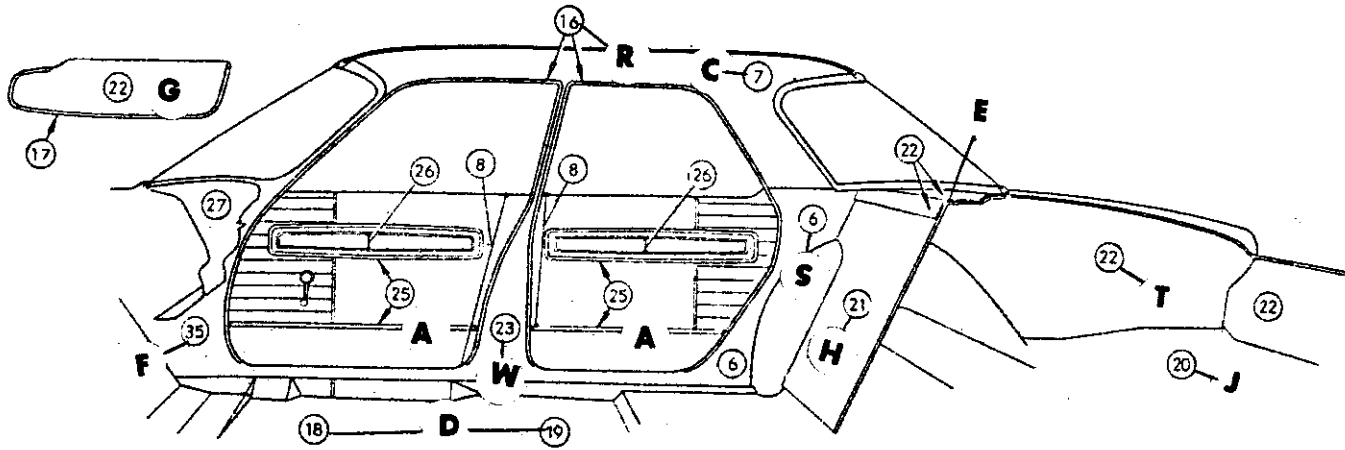

FRONT SEAT

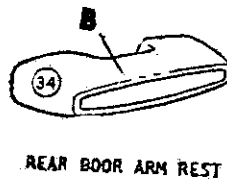

REAR DOOR ARM REST

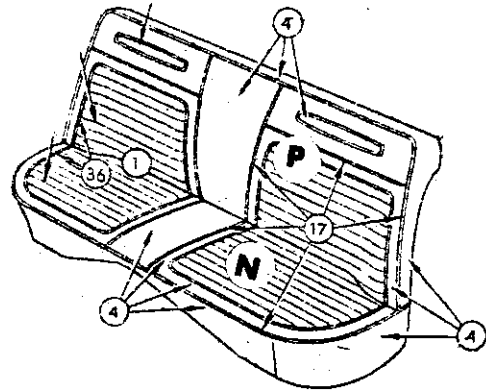

REAR SEAT

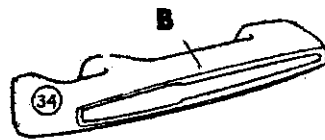

FRONT DOOR ARM REST

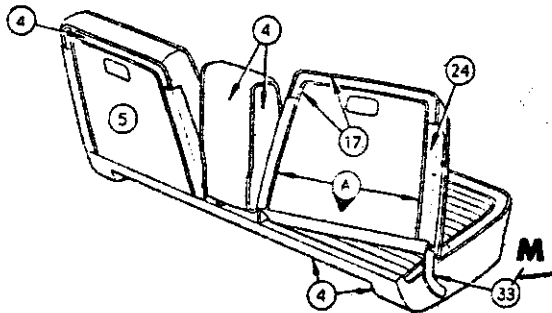

FRONT SEAT (BACK)

DISTRIBUTION OF MATERIAL

- 3 HEADLINING
- 4 IMITATION LEATHER 28-AM-22
- 5 IMITATION LEATHER 20-DT-77
- 6 IMITATION LEATHER 19-C-22
- 7 IMITATION LEATHER 17-C-81 OPT 15, 5-C-81
- 8 IMITATION LEATHER 19-DJ-22
- 17 EXTRUDED VINYL
- 18 FLOOR COVERING-FRONT CARPET
- 19 FLOOR COVERING-REAR CARPET
- 21 CARBOARD
- 22 EMBOSSED CARDBOARD
- 32 CARPET
- 33 PLASTIC
- 34 PLASTISOL
- 35 POLYETHLENE
- 36 EXTRUDED VINYL-MYLAR FILLER

Distribution Drawing Legend Page Appears Following Illustration Section

Codes 541, 543, 545, 546, 548

TDH-411

1963 DODGE TD1-H, TD2-H 4 DOOR SEDAN  
CLOTH & VINYL



1963 DODGE - T SERIES

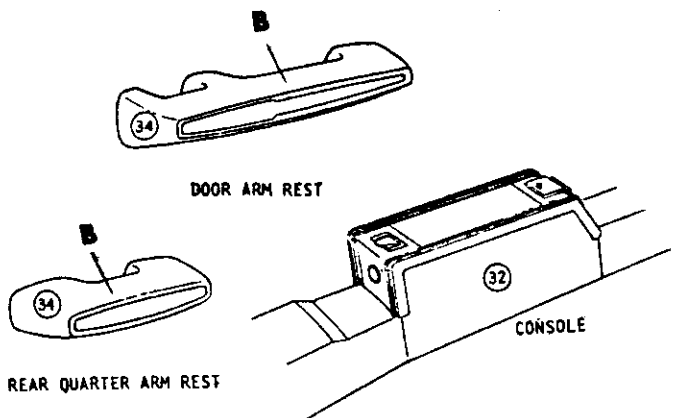
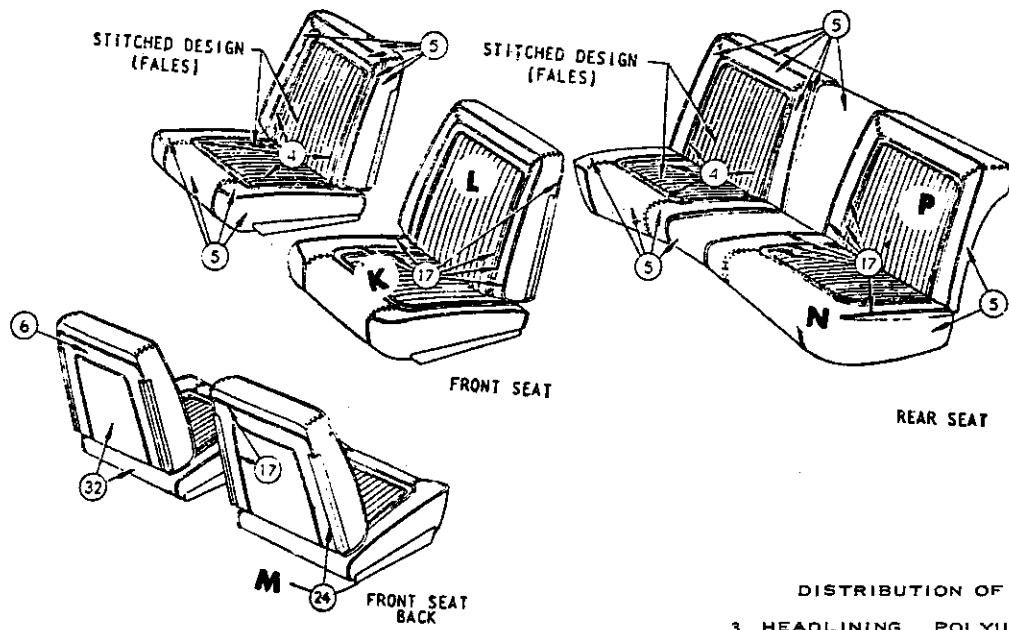
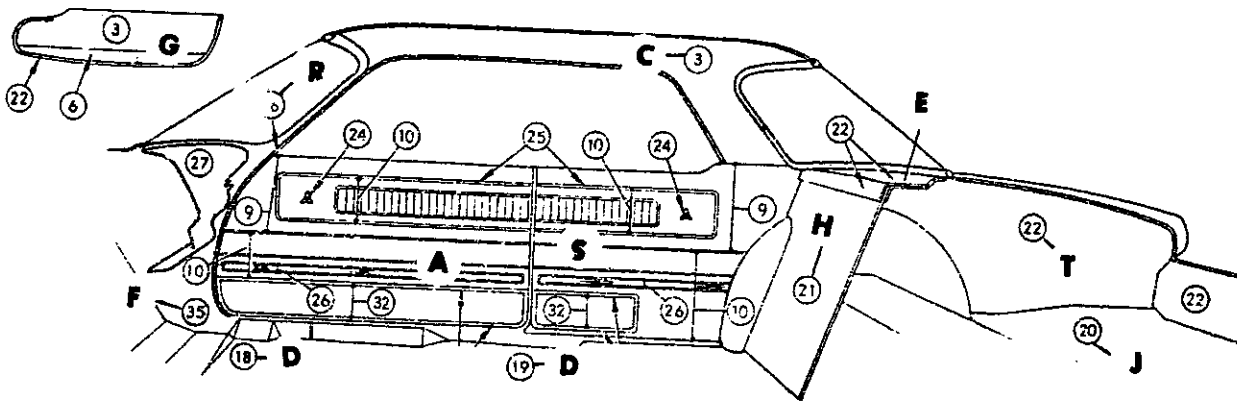

DISTRIBUTION OF MATERIAL

- 3 HEADLINING POLYURETHANE
- 4 IMITATION LEATHER 28-AM-22
- 5 IMITATION LEATHER 28A-AM-22
- 6 IMITATION LEATHER 19-C-22
- 8 IMITATION LEATHER 19B-C-22
- 9 IMITATION LEATHER 19-DJ-22
- 10 IMITATION LEATHER .012-L-22
- 16 LACE
- 17 EXTRUDED VINYL
- 18 FLOOR COVERING-FRONT-CARPET
- 19 FLOOR COVERING-REAR-CARPET
- 20 FLOOR COVERING-LUGG. COMPT. RUBBER
- 21 CARDBOARD
- 22 EMBOSSED CARDBOARD
- 23 PAINT
- 24 METAL
- 25 MOULDING
- 26 MYLAR
- 27 MOULDED RESIN
- 28 MOULDED RUBBER
- 29 MOULDED VINYL
- 32 CARPET
- 33 PLASTIC
- 34 PLASTISOL
- 35 POLYETHLENE

Distribution Drawing Legend Page Appears Following Illustration Section

Codes 651, 653, 655, 656, 658

TDP-234

1963 DODGE TD2-P SPECIAL CLUB COUPE  
IMITATION LEATHER TRIM

1963 DODGE - T SERIES

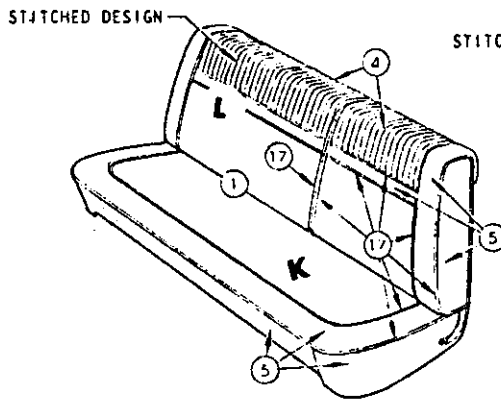
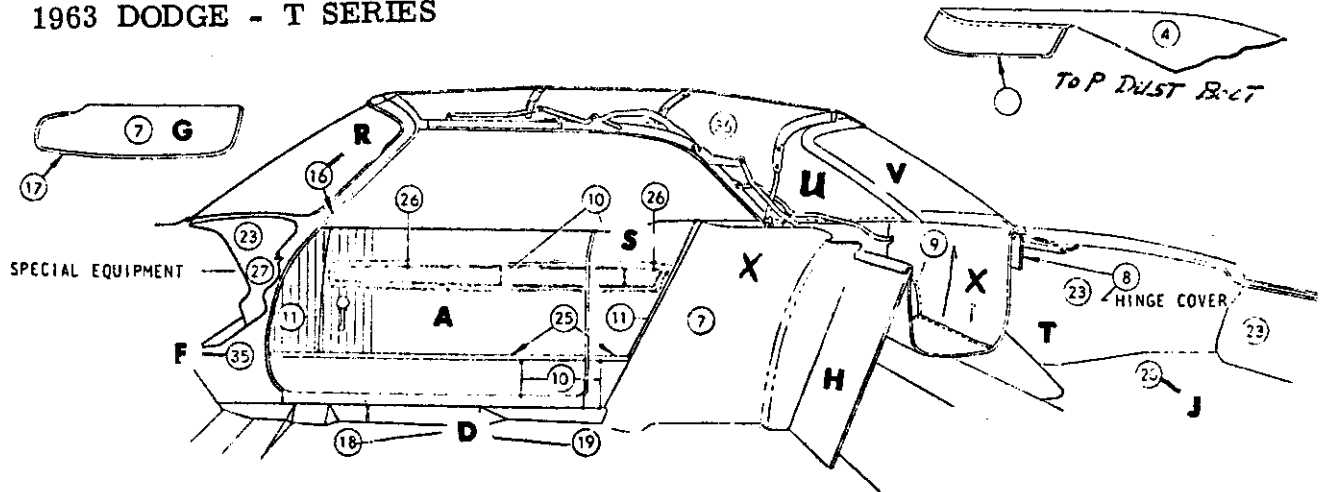

FRONT SEAT

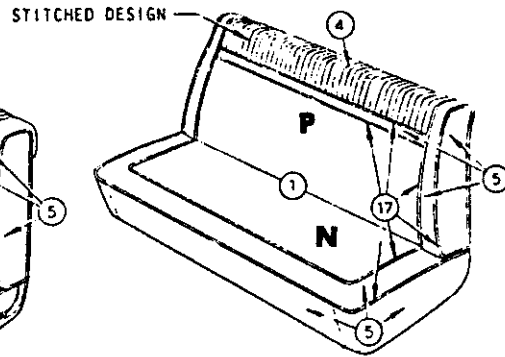

REAR SEAT

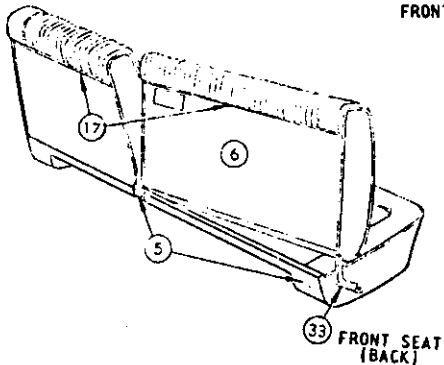

FRONT SEAT (BACK)

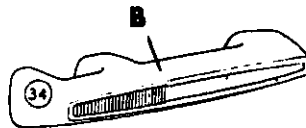

DOOR ARM REST

DISTRIBUTION OF MATERIAL

1	BODY CLOTH	I
4	IMITATION LEATHER	28-AM-22
5	IMITATION LEATHER	28A-AM-22
6	IMITATION LEATHER	19-C-22
7	IMITATION LEATHER	19A-C-22
8	IMITATION LEATHER	19B-C-22
9	IMITATION LEATHER	19C-C-22
10	IMITATION LEATHER	21-CM-22
11	IMITATION LEATHER	19-DJ-22
16	LACE	
17	EXTRUDED VINYL	
18	FLOOR COVERING-FRONT-CARPET	
19	FLOOR COVERING-REAR-CARPET	
20	FLOOR COVERING-LUGG. COMPT. RUBBER	
23	PAIN	
24	METAL	
25	MOULDING	
26	MYLAR	
27	MOULDED RESIN	
28	MOULDED RUBBER	
29	MOULDED VINYL	
32	CARPET	
33	PLASTIC	
34	PLASTISOL	
35	POLYETHLENE	
36	TOP MATERIAL	

Distribution Drawing Legend Page Appears Following Illustration Section

Codes 521, 523, 525, 526, 528

TDM-271

1963 DODGE TD 2-M CONVERTIBLE COUPE  
CLOTH & IMITATION LEATHER COMBINATION

1963 DODGE - T SERIES

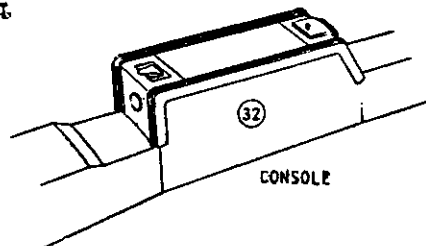
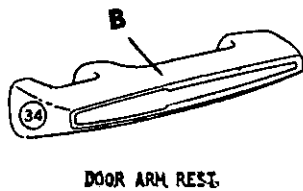
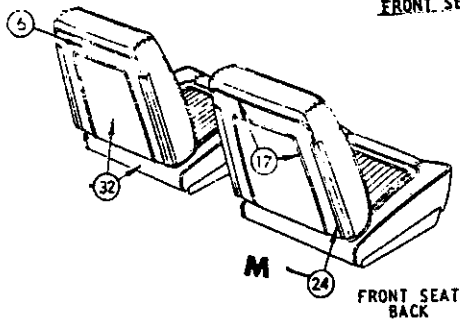
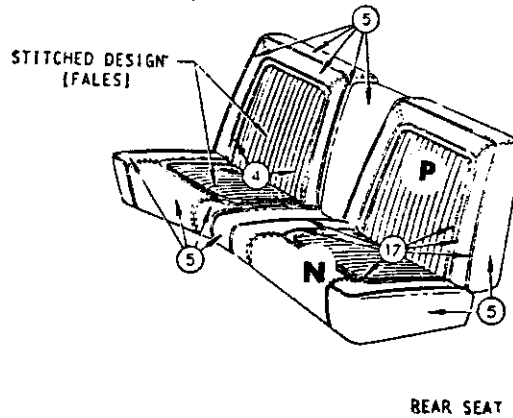
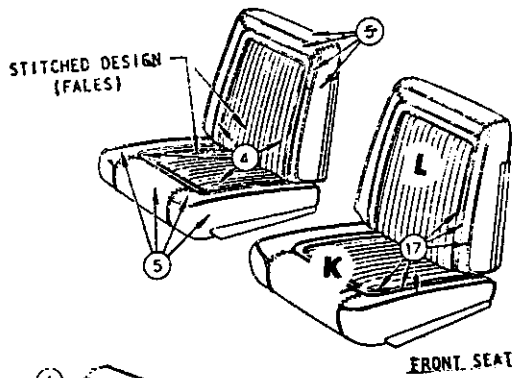
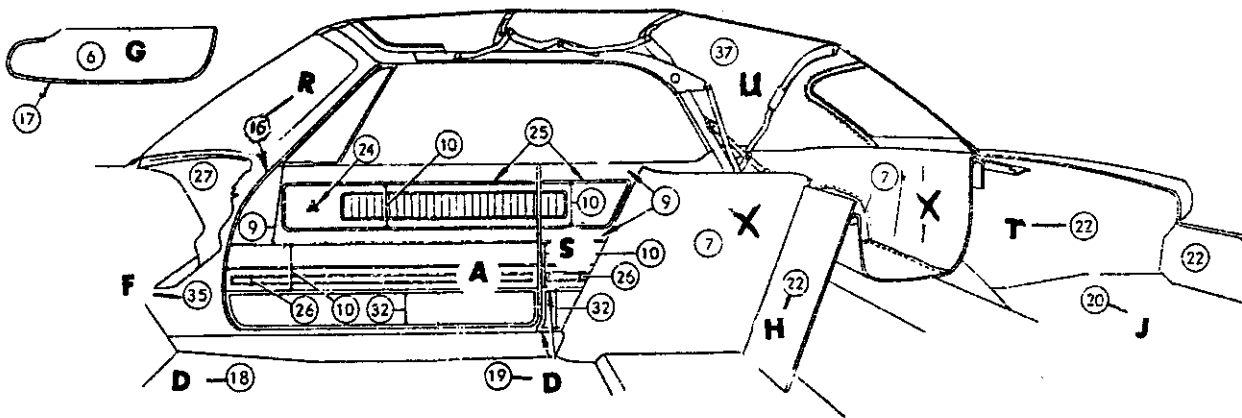

DISTRIBUTION OF MATERIAL

4	IMITATION LEATHER	28-AM-22
5	IMITATION LEATHER	28A-AM-22
6	IMITATION LEATHER	19-C-22
7	IMITATION LEATHER	19A-C-22
8	IMITATION LEATHER	19B-C-22
9	IMITATION LEATHER	19-DJ-22
10	IMITATION LEATHER	.012-L-22
16	LACE	
17	EXTRUDED VINYL	
18	FLOOR COVERING-FRONT-CARPET	
19	FLOOR COVERING-REAR-CARPET	
20	FLOOR COVERING-LUGG. COMPT. RUBBER	
22	EMBOSSED CARDBOARD	
23	PAINT	
24	METAL	
25	MOULDING	
26	MYLAR	
27	MOULDED RESIN	
28	MOULDED RUBBER	
29	MOULDED VINYL	
32	CARPET	
33	PLASTIC	
34	PLASTISOL	
35	POLYETHYLENE	
37	TOP MATERIAL	

Distribution Drawing Legend Page Appears Following Illustration Section

Codes 651, 653, 655, 656, 658

TDP-274

1963 DODGE TD2-P CONVERTIBLE COUPE  
IMITATION LEATHER TRIM

1963 DODGE - T SERIES

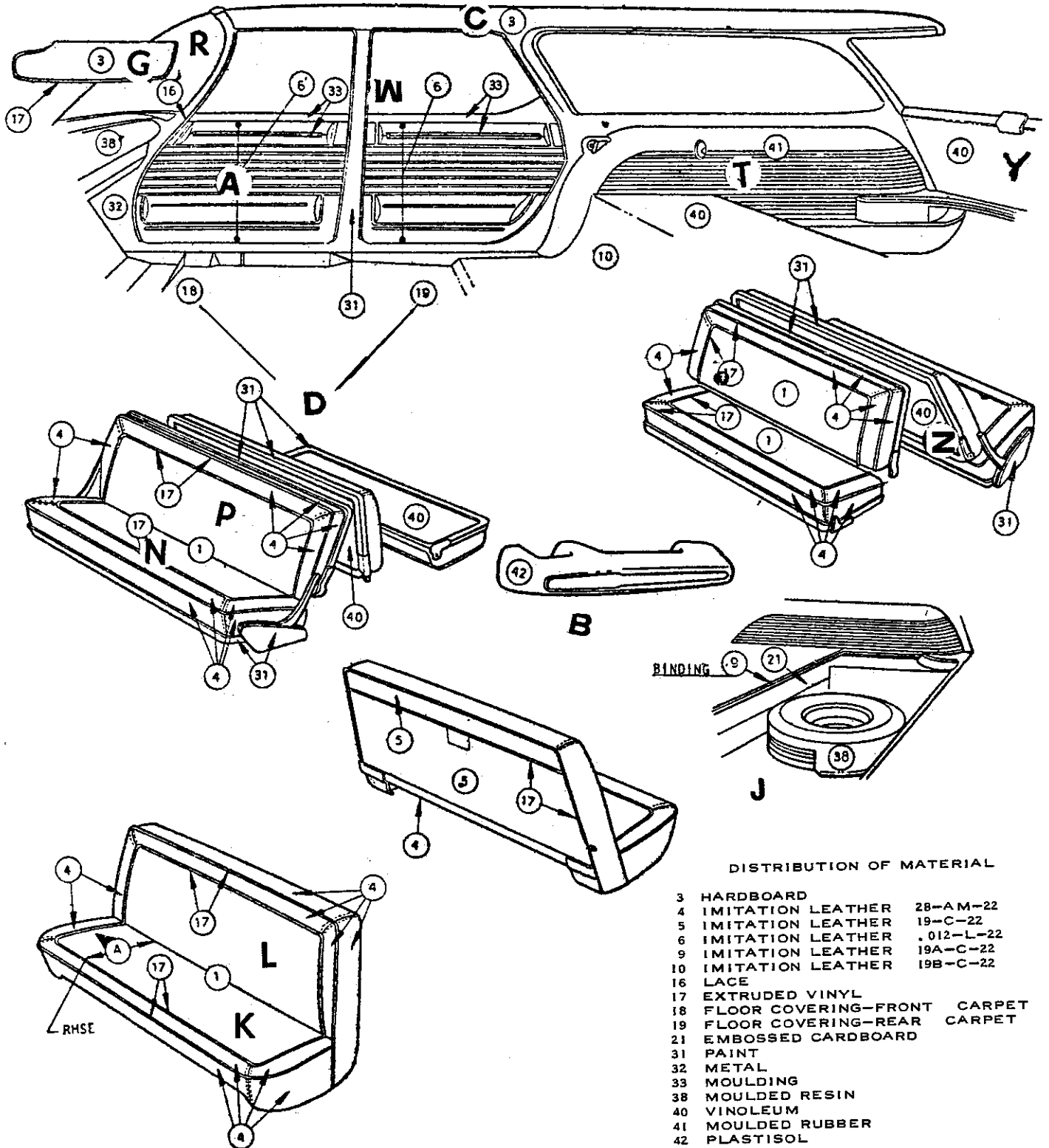

Distribution Drawing Legend Page Appears Following Illustration Section

Codes 561, 563, 565, 568

TAE-451

1963 DODGE TA3-E 4 DOOR STATION WAGON  
CLOTH & IMITATION LEATHER TRIM





1963 DODGE - T SERIES

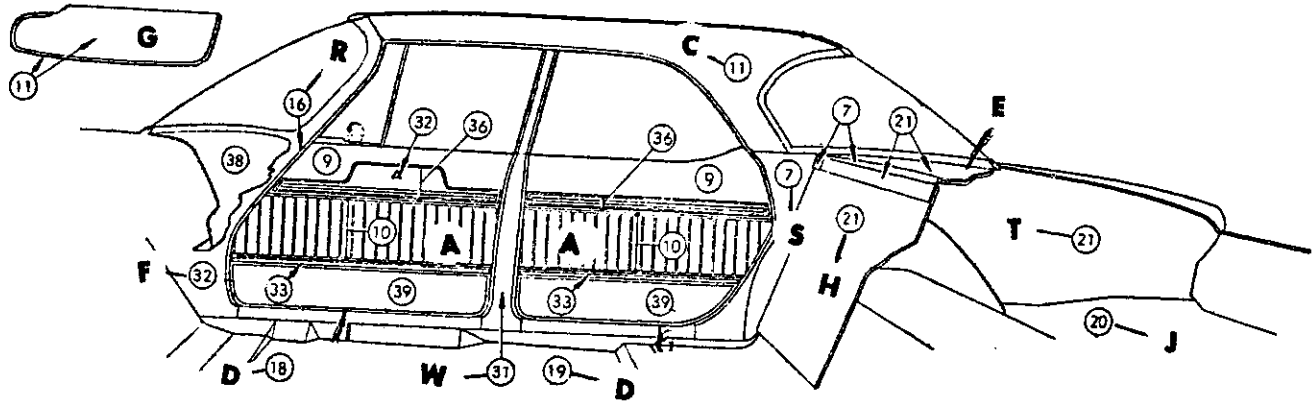

STITCHED DESIGN  
(FALES)

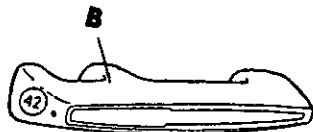
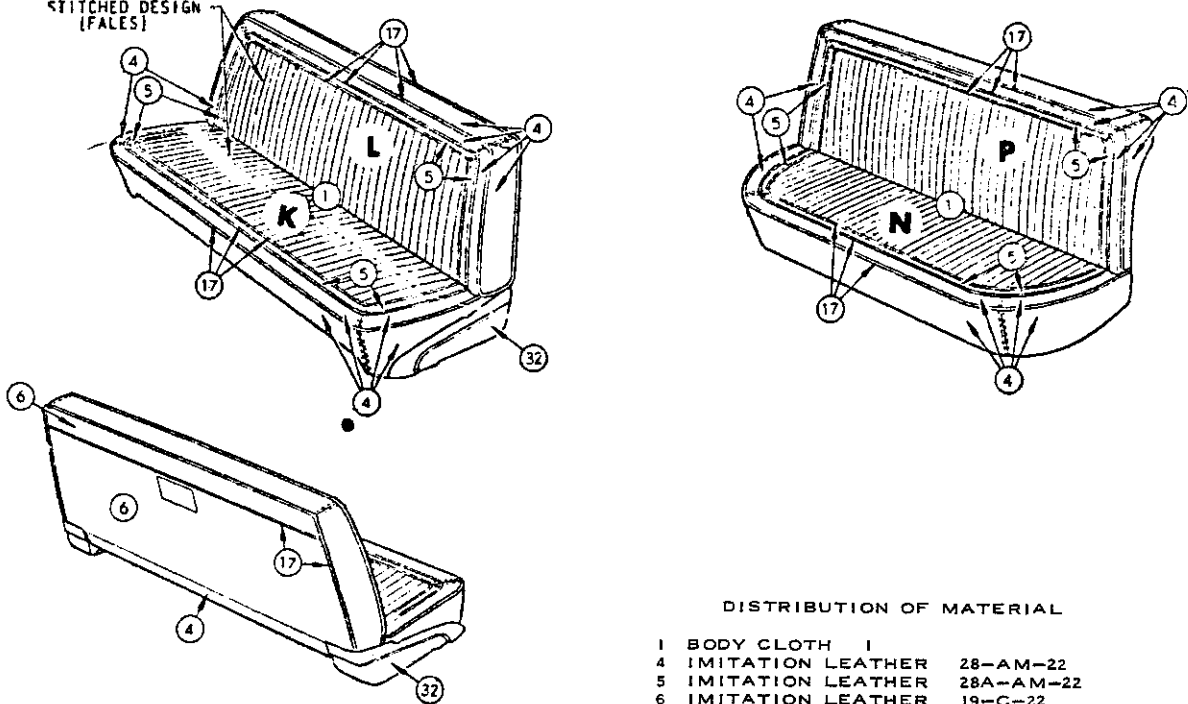

DISTRIBUTION OF MATERIAL

- |    |                                    |                        |
|----|------------------------------------|------------------------|
| 1  | BODY CLOTH                         | 1                      |
| 4  | IMITATION LEATHER                  | 28-AM-22               |
| 5  | IMITATION LEATHER                  | 28A-AM-22              |
| 6  | IMITATION LEATHER                  | 19-C-22                |
| 7  | IMITATION LEATHER                  | 19A-C-22               |
| 9  | IMITATION LEATHER                  | 19-DJ-22               |
| 10 | IMITATION LEATHER                  | 19A-DJ-22              |
| 11 | IMITATION LEATHER                  | 17-C-81 OPT 15, 5-C-81 |
| 16 | LACE                               |                        |
| 17 | EXTRUDED VINYL                     |                        |
| 18 | FLOOR COVERING-FRONT-CARPET        |                        |
| 19 | FLOOR COVERING-REAR-CARPET         |                        |
| 20 | FLOOR COVERING-LUGG. COMPT. RUBBER |                        |
| 21 | EMBOSSED CARDBOARD                 |                        |
| 30 | PLASTIC                            |                        |
| 31 | PAINT                              |                        |
| 32 | METAL                              |                        |
| 33 | MOULDING                           |                        |
| 36 | MYLAR                              |                        |
| 38 | MOULDED RESIN                      |                        |
| 39 | CARPET                             |                        |
| 42 | PLASTISOL                          |                        |

Distribution Drawing Legend Page Appears Following Illustration Section

Codes 571, 572, 573, 575, 578

TAL-411

1963 DODGE TA3-L 4 DOOR SEDAN  
CLOTH & IMITATION LEATHER TRIM

1963 DODGE - T SERIES

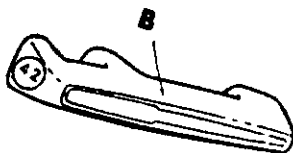
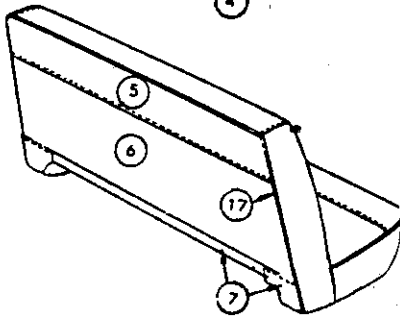
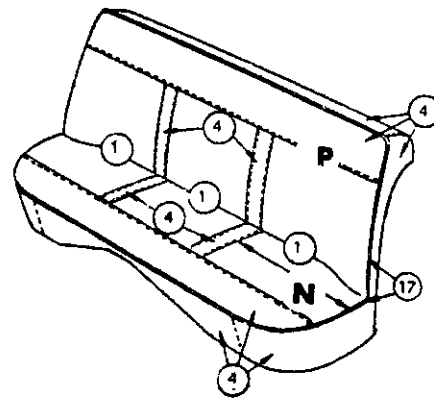
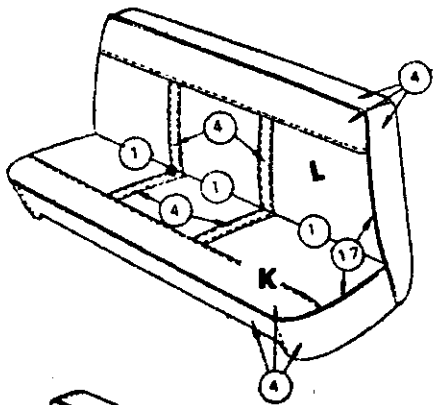
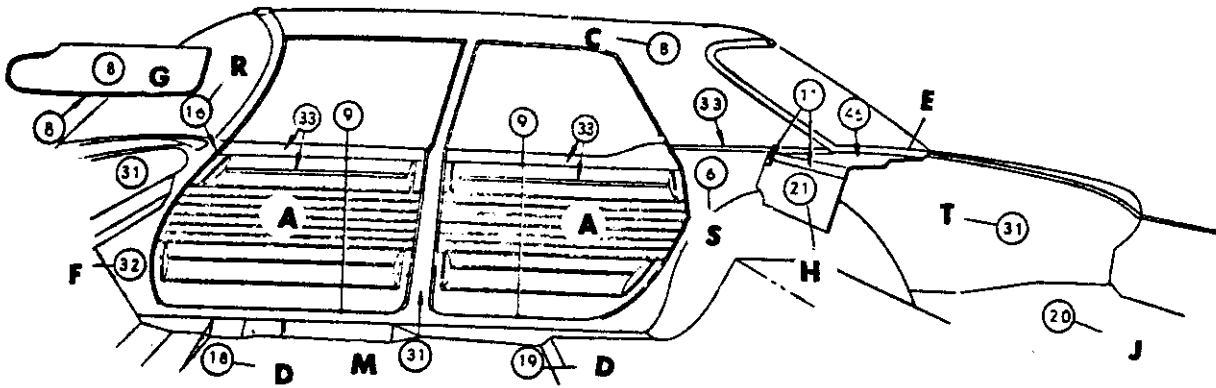

DISTRIBUTION OF MATERIAL

- 1 BODY CLOTH, I
- 4 IMITATION LEATHER 28-AM-22
- 5 IMITATION LEATHER 19-C-22
- 6 IMITATION LEATHER 19A-C-22
- 7 IMITATION LEATHER 28A-AM-22
- 8 IMITATION LEATHER 15, 5-C-81
- 9 IMITATION LEATHER .012-L-22
- 11 IMITATION LEATHER 28B-AM-22
- 16 LACE
- 17 EXTRUDED VINYL
- 18 FLOOR COVERING-FRONT-RUBBER
- 19 FLOOR COVERING-REAR-RUBBER
- 20 FLOOR COVERING-LUGG. COMPT. RUBBER
- 21 EMBOSSED CARDBOARD
- 30 PLASTIC
- 31 PAINT
- 32 METAL
- 33 MOULDING
- 36 MYLAR
- 38 MOULDED RESIN
- 42 PLASTISOL
- 46 HARDBOARD

Distribution Drawing Legend Page Appears Following Illustration Section

Code 584

TAL-411A

1963 DODGE TA3-L 4 DOOR SEDAN  
CLOTH & IMITATION LEATHER TRIM

1963 DODGE - T SERIES

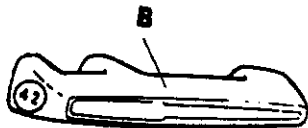
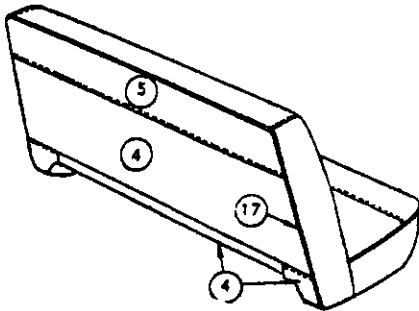
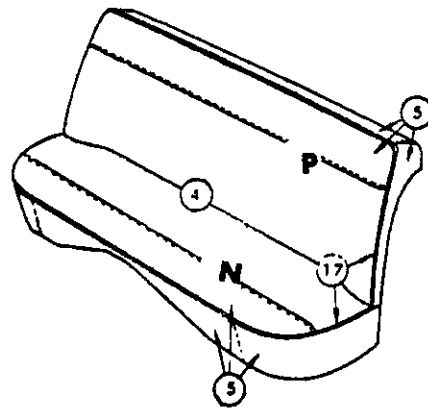
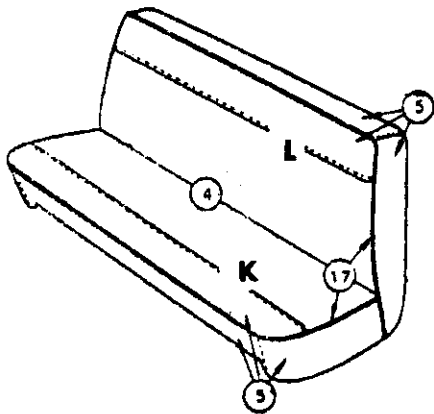
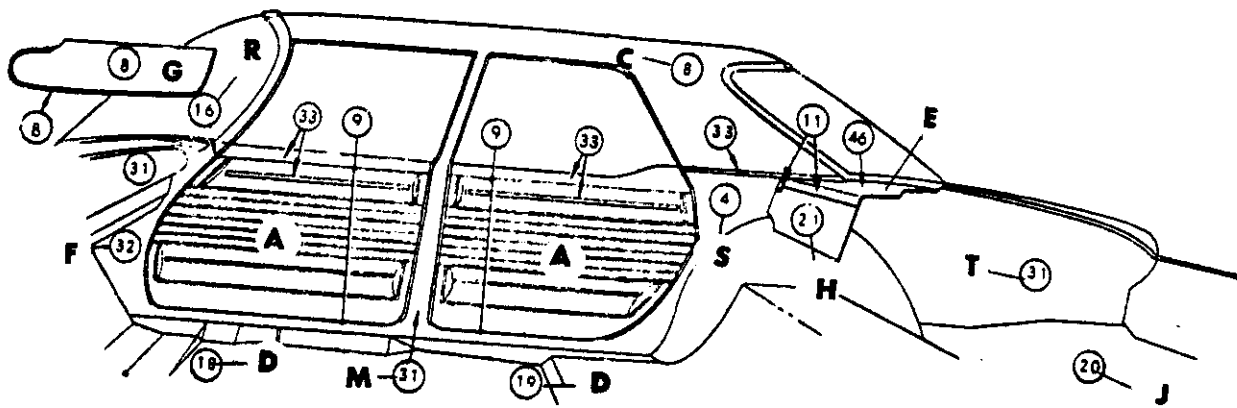

DISTRIBUTION OF MATERIAL

- 4 IMITATION LEATHER 37-CX-22
- 5 IMITATION LEATHER 37A-CX-22
- 7 IMITATION LEATHER 19-C-22
- 8 IMITATION LEATHER 15, 5-C-81
- 9 IMITATION LEATHER .012-L-22
- 11 IMITATION LEATHER 28-AM-22
- 16 LACE
- 17 EXTRUDED VINYL
- 18 FLOOR COVERING-FRONT-RUBBER
- 19 FLOOR COVERING-REAR-RUBBER
- 20 FLOOR COVERING-LUGG. COMPT. RUBBER
- 21 EMBOSSED CARDBOARD
- 30 PLASTIC
- 31 PAINT
- 32 METAL
- 33 MOULDING
- 36 MYLAR
- 38 MOULDED RESIN
- 42 PLASTISOL
- 46 HARDBOARD

Distribution Drawing Legend Page Appears Following Illustration Section

Code 684

TAL-414

1963 DODGE TA3-L 4 DOOR SEDAN  
IMITATION LEATHER TRIM

1963 DODGE - T SERIES

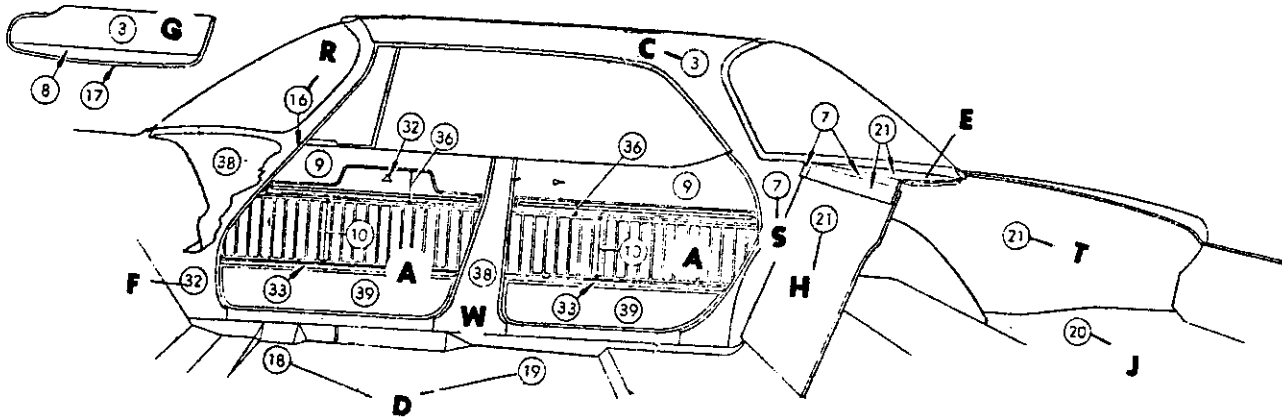

STITCHED DESIGN (FACES)

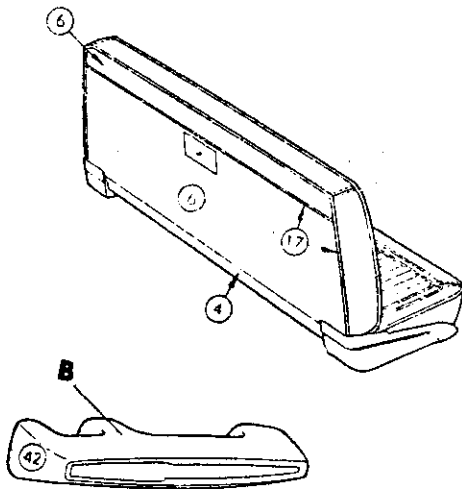
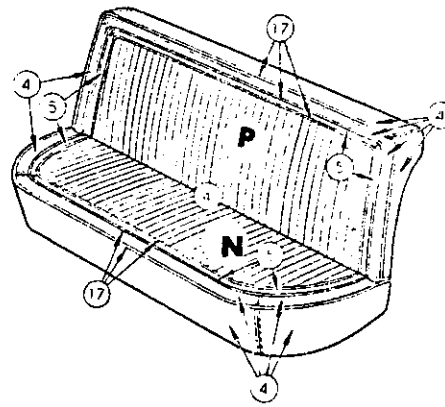
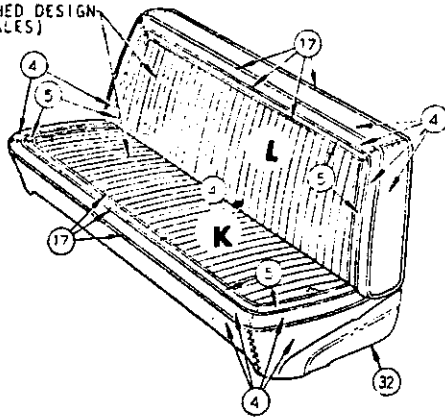

DISTRIBUTION OF MATERIAL

- 3 HEADLINING POLYURETHANE
- 4 IMITATION LEATHER 28-AM-22
- 5 IMITATION LEATHER 28A-AM-22
- 6 IMITATION LEATHER 19-C-22
- 7 IMITATION LEATHER 19A-C-22
- 8 IMITATION LEATHER 19B-C-22
- 9 IMITATION LEATHER 19-DJ-22
- 10 IMITATION LEATHER 19A-DJ-22
- 16 LACE
- 17 EXTRUDED VINYL
- 18 FLOOR COVERING-FRONT-CARPET
- 19 FLOOR COVERING-REAR-CARPET
- 20 FLOOR COVERING-LUGG. COMPT, RUBBER
- 21 EMBOSSED CARDBOARD
- 30 PLASTIC
- 31 PAINT
- 32 METAL
- 33 MOULDING
- 36 MYLAR
- 38 MOULDED RESIN
- 39 CARPET
- 42 PLASTISOL

Distribution Drawing Legend Page Appears Following Illustration Section

Codes 671, 672, 673, 675, 678

TAL-434

1963 DODGE TA3-L 4 DOOR HARDTOP  
IMITATION LEATHER TRIM

1963 DODGE - T SERIES

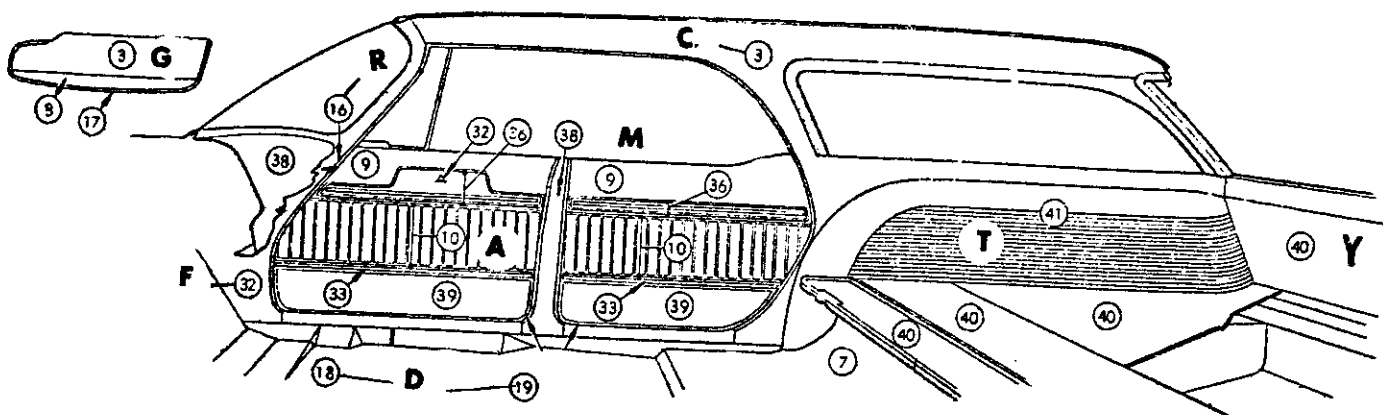

STITCHED DESIGN (FALES)

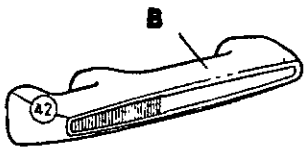
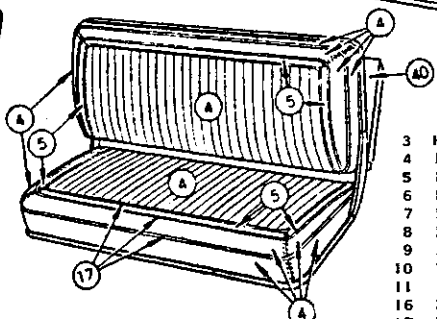
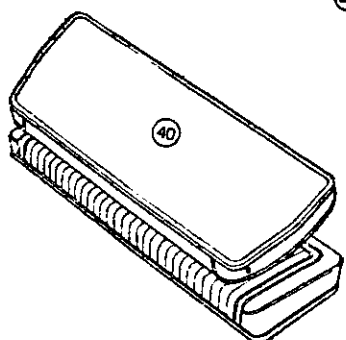
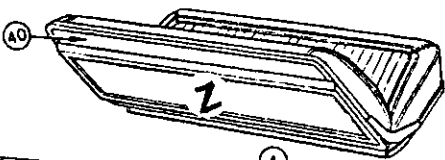
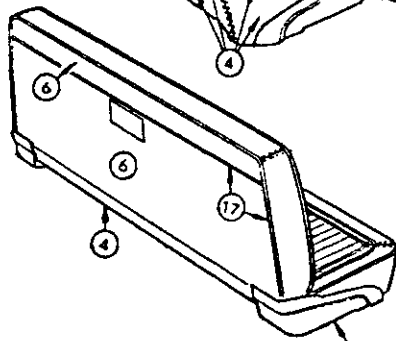
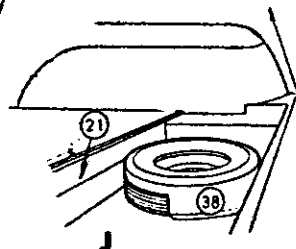
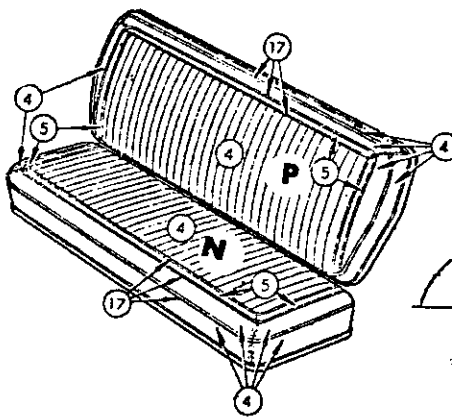
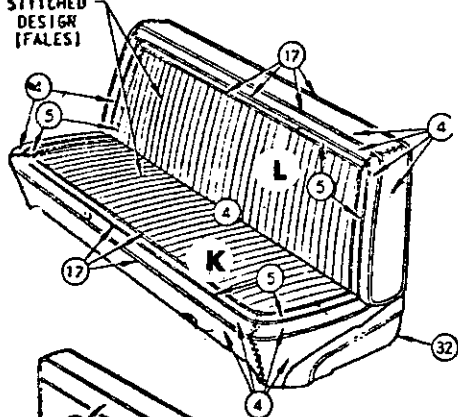

FRONT & REAR DOOR ARM REST

DISTRIBUTING OF MATERIAL

3	HEADLINING	POLYURETHANE
4	IMITATION LEATHER	28-AM-22
5	IMITATION LEATHER	28A-AM-22
6	IMITATION LEATHER	19-C-22
7	IMITATION LEATHER	19A-C-22
8	IMITATION LEATHER	19B-C-22
9	IMITATION LEATHER	19-DJ-22
10	IMITATION LEATHER	19A-DJ-22
11	IMITATION LEATHER	19C-C-22
16	LACE	
17	EXTRUDED VINYL	
18	FLOOR COVERING-FRONT-CARPET	
19	FLOOR COVERING-REAR-CARPET	
21	EMBOSSED CARDBOARD	
32	METAL	
33	MOULDING	
36	MYLAR	
38	MOULDED RESIN	
39	CARPET	
40	VINOLEUM	
42	PLASTISOL	

Distribution Drawing Legend Page Appears Following Illustration Section

Codes 671, 672, 673, 675, 678

TAL-464

1963 DODGE TA3-L 4 DOOR HARDTOP SUBURBAN  
IMITATION LEATHER TRIM

1963 DODGE - T SERIES

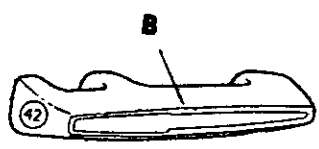
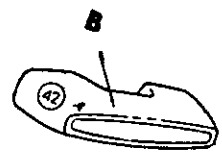
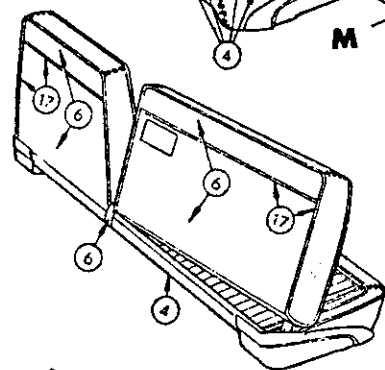
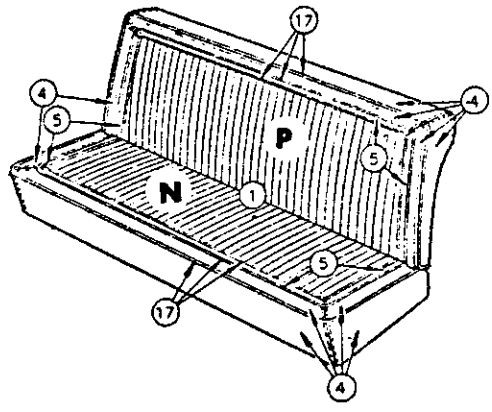
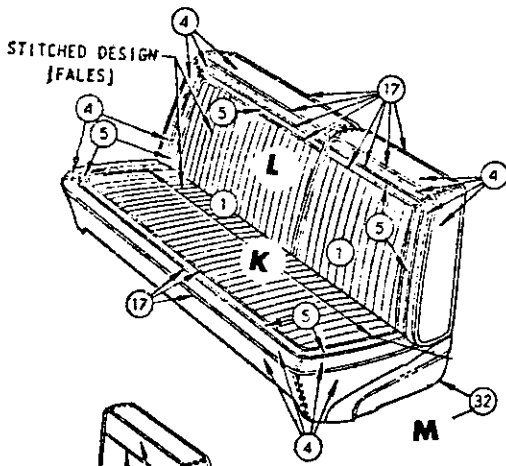
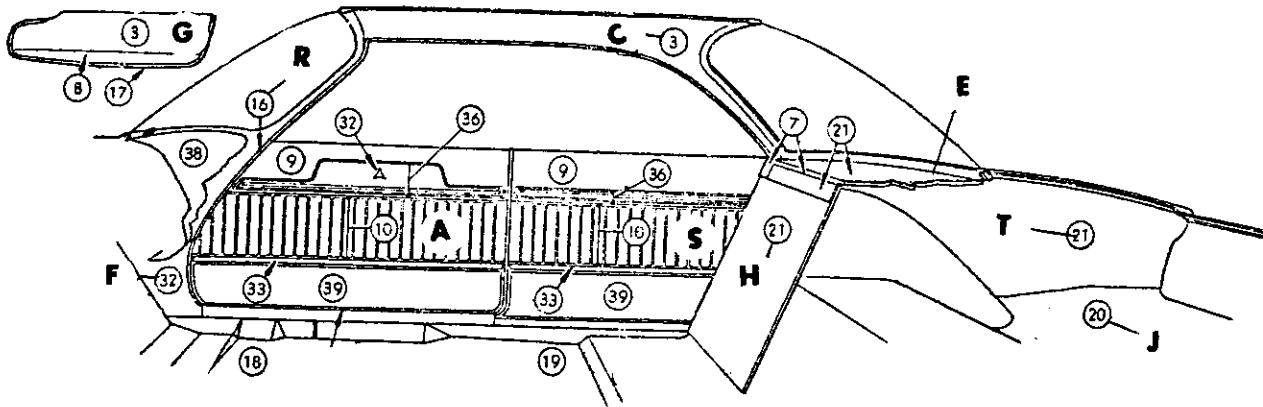

DISTRIBUTION OF MATERIAL

- 1 BODY CLOTH I
- 3 HEADLINING POLYURETHANE
- 4 IMITATION LEATHER 28-AM-22
- 5 IMITATION LEATHER 28A-AM-22
- 6 IMITATION LEATHER 19-C-22
- 7 IMITATION LEATHER 19A-C-22
- 8 IMITATION LEATHER 19B-C-22
- 9 IMITATION LEATHER 19-DJ-22
- 10 IMITATION LEATHER 19A-DJ-22
- 16 LACE
- 17 EXTRUDED VINYL
- 18 FLOOR COVERING-FRONT-CARPET
- 19 FLOOR COVERING-REAR-CARPET
- 20 FLOOR COVERING-LUGG. COMPT. RUBBER
- 21 EMBOSSED CARDBOARD
- 32 METAL
- 33 MOULDING
- 36 MYLAR
- 38 MOULDED RESIN
- 39 CARPET
- 42 PLASTISOL

Distribution Drawing Legend Page Appears Following Illustration Section

Codes 571, 572, 573, 575, 578

TAL-231

1963 DODGE TA3-L 2 DOOR HARDTOP  
CLOTH & IMITATION LEATHER TRIM

1963 DODGE - T SERIES

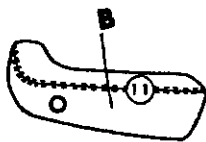
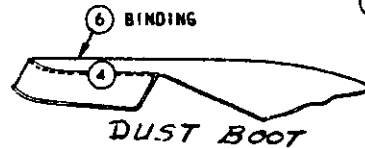
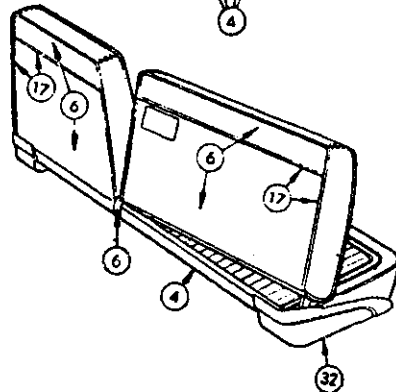
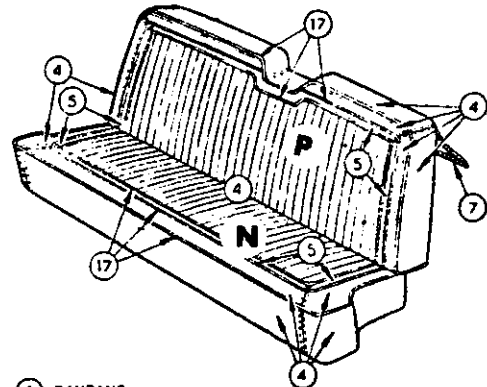
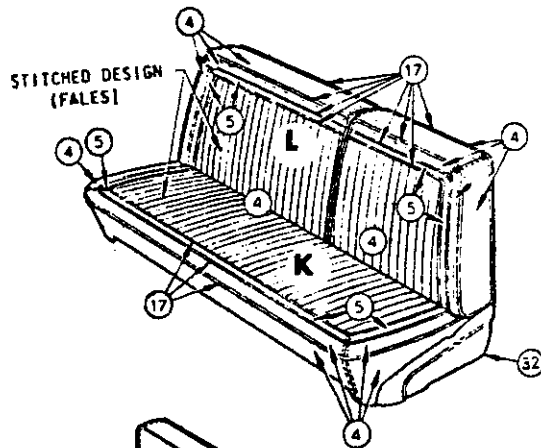
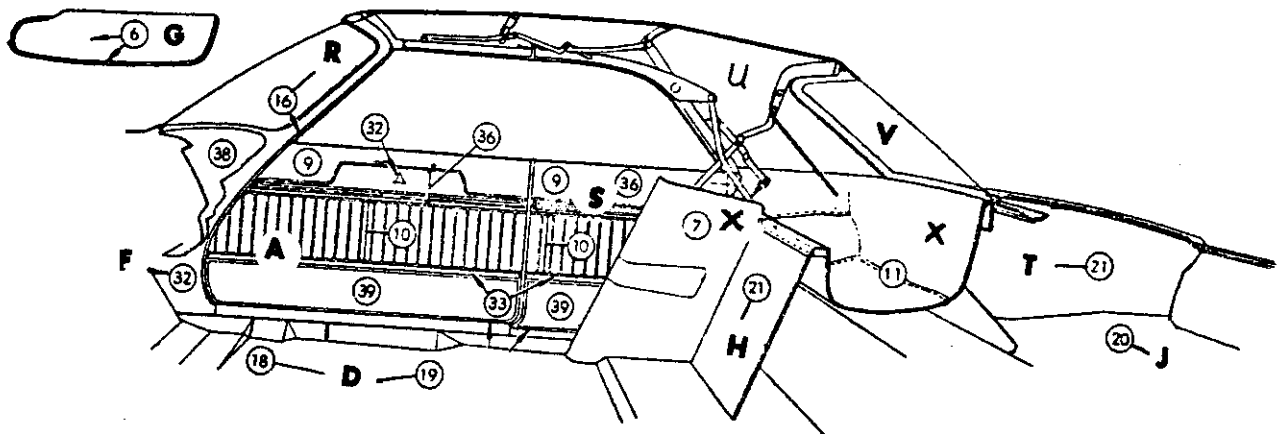

DISTRIBUTION OF MATERIAL

4	IMITATION LEATHER	28-AM-22
5	IMITATION LEATHER	28A-AM-22
6	IMITATION LEATHER	19-C-22
7	IMITATION LEATHER	19A-C-22
9	IMITATION LEATHER	19-DJ-22
10	IMITATION LEATHER	19A-DJ-22
11	IMITATION LEATHER	28B-AM-22
16	LACE	
17	EXTRUDED VINYL	
18	FLOOR COVERING-FRONT-CARPET	
19	FLOOR COVERING-REAR-CARPET	
20	FLOOR COVERING-LUGG. COMPT. RUBBER	
21	EMBOSSED CARDBOARD	
32	METAL	
33	MOULDING	
36	MOULDED RESIN	
39	CARPET	
42	PLASTISOL	

Distribution Drawing Legend Page Appears Following Illustration Section

Codes 671, 672, 673, 675, 678

TAL-274

1963 DODGE TA3-L CONVERTIBLE COUPE  
IMITATION LEATHER TRIM

## 1963 DODGE AND DART - T SERIES

## Distribution Drawing Legend

See Illustrations For Letter Identification

Letter	Description	Code
A	Panel, Door Trim	23-92-5
B	Arm Rest, Door, Front	23-76-3
	Center, Front Seat	23-76-34
	Door, Rear	23-76-59
	Quarter Panel	23-76-66
C	Headlining	23-86-3
D	Floor Cover, Front, Carpet	23-79-3
	Rubber	23-20-8
	Rear, Carpet	23-79-33
	Rubber	23-20-41
E	Panel, Shelf Trim	23-102-3
F	Panel, Cowl Trim	23-91-6
G	Visor	23-103-3
H	Panel, Luggage Compartment Front	23-96-3
J	Cover, Luggage Compartment Floor	23-20-29
K	Cover, Front Seat Cushion	23-108-5
L	Cover, Front Seat Back	23-108-16
M	Cover, Front Seat Hinge	23-108-84
N	Cover, Rear Seat Cushion	23-109-36
P	Cover, Rear Seat Back	23-109-4
Q	Cover, Rear Seat Cushion Bottom Panel	23-109-40
R	Weathercord, Door	23-113-2
	Hinge Pillar	23-113-25
	Lock Pillar	23-113-30
	w/Weatherstrip	23-66-33
S	Panel, Quarter Trim	23-101-3
T	Cover, Wheelhouse	23-96-8
U	Top Deck and Side Quarter	23-112-108
V	Curtain, Folding Top Back	23-112-45
W	Cover, Center Pillar	23-99-4
X	Panel, Folding Top Well Pocket	23-112-153
Y	Cover, Tailgate Inside Panel	23-79-79
Z	Cover, Rear Seat Back Panel	23-109-5



1963 DART - DODGE T SERIES

BODY CODE	COLUMN LEGEND
TL1-L (170)	
711 (21)	2 D. Sedan
713 (41)	4 D. Sedan
756 (45A)	4 D. Wagon (2 Seat)
TL1-H (770)	
731 (21)	2 D. Sedan
753 (41)	4 D. Sedan
735 (27)	Convertible
776 (45A)	4 D. Wagon (2 Seat)
TL1-P (GT)	
742 (23)	2 D. Hard Top
745 (27)	Convertible
TD1-L	
401 (21)	2 D. Sedan (Fleet)
403 (41)	4 D. Sedan (Fleet)
411 (21)	2 D. Sedan
413 (41)	4 D. Sedan
456 (45A)	4 D. Wagon (2 Seat)
457 (45B)	4 D. Wagon (3 Seat)
483 (41)	4 D. Sedan (Taxi)
491 (21)	2 D. Sedan (Police)
493 (41)	4 D. Sedan (Police)
496 (45A)	4 D. Wagon (Police) (2 Seat)
TD2-L	
601 (21)	2 D. Sedan (Fleet)
603 (41)	4 D. Sedan (Fleet)
611 (21)	2 D. Sedan
613 (41)	4 D. Sedan
656 (45A)	4 D. Wagon (2 Seat)
657 (45B)	4 D. Wagon (3 Seat)
683 (41)	4 D. Sedan (Taxi)
691 (21)	2 D. Sedan (Police)
693 (41)	4 D. Sedan (Police)
696 (45A)	4 D. Sedan (Police) (2 Seat)
TD1-M (440)	
421 (21)	2 D. Sedan
422 (23)	2 D. Hard Top
423 (41)	4 D. Sedan
TD2-M (440)	
621 (21)	2 D. Sedan
622 (23)	2 D. Hard Top
623 (41)	4 D. Sedan
666 (45A)	4 D. Wagon (2 Seat)
667 (45B)	4 D. Wagon (3 Seat)

★ Indicates use as required.

☐ Indicates parts not listed in any previous parts book.  
 Right and left part numbers are on same line,  
 first number is right, second number is left.

Printed in U.S.A.  
 Prices and specifications subject to change without notice.  
 September 4, 1962.

BODY CODE		COLUMN LEGEND			
TD1-H (440)					
432 (23)		2 D. Hard Top			
433 (41)		4 D. Sedan			
POLARA TD2-H					
632 (23)		2 D. Hard Top			
633 (41)		4 D. Sedan			
634 (43)		4 D. Hard Top			
635 (27)		Convertible			
POLARA TD2-P (500)					
642 (23)		2 D. Hard Top			
645 (27)		Convertible			
TA3-E (880)					
503 (41)		4 D. Sedan			
556 (45A)		4 D. Wagon (2 Seat)			
557 (45B)		4 D. Wagon (3 Seat)			
593 (41)		4 D. Sedan (Police)			
596 (45A)		4 D. Wagon (2 Seat)			
TA3-L (880)					
512 (23)		2 D. Hard Top			
513 (41)		4 D. Sedan			
514 (43)		4 D. Hard Top			
515 (27)		Convertible			
558 (46A)		4 D. Wagon (2 Seat)			
559 (46B)		4 D. Wagon (3 Seat)			
CONVERTIBLE TOP COLOR LEGEND					
TD2-H		6 Black		7 White	
TD2-P		6 Black		8 Beige	
STARTING SERIAL NUMBERS					
		Detroit Built	St. Louis Built	Newark Built	Los Angeles Built
TL1-L	(Dart 170)	7132-500001	7137-100001	7136-100001	7135-100001
TL1-L	(Dart Sub. 170)	7532-500001	7537-100001	7536-100001	7535-100001
TL1-H	(Dart 770)	7332-100001	7337-100001	7336-100001	7335-100001
TL1-H	(Dart Sub. 770)	7732-100001	7737-100001	7736-100001	7735-100001
TL1-P	(G. T.)	7432-100001	7437-100001	7436-100001	7435-100001
TD1-L	(Dodge)	4132-100001	4137-100001	4136-100001	4135-100001
TD1-L	(Dodge Sub.)	4532-100001	4537-100001	4536-100001	4535-100001
TD1-M	(Dodge 330)	4232-100001	4237-100001	4236-100001	4235-100001
TD1-M	(Dodge 330 Sub.)	4632-100001	4637-100001	4636-100001	4635-100001
TD1-H	(Dodge 440)	4332-100001	4337-100001	4336-100001	4335-100001
TD2-L	(Dodge)	6132-100001	6137-100001	6136-100001	6135-100001
TD2-L	(Dodge Sub.)	6532-100001	6537-100001	6536-100001	6535-100001
TD2-M	(Dodge 330)	6232-100001	6237-100001	6236-100001	6235-100001
TD2-M	(Dodge 330 Sub.)	6632-100001	6637-100001	6636-100001	6635-100001
TD2-H	(Dodge 440)	6332-100001	6337-100001	6336-100001	6335-100001
TD2-H	(Dodge 440 Sub.)	6732-100001	6737-100001	6736-100001	6735-100001
TD2-P	(Polar 500)	6432-100001			
TA3-E	(Custom 880)	5133-100001			
TA3-L	(Custom 880)	5133-100001			

★ Indicates use as required.

⊠ Indicates parts not listed in any previous parts book.

Dec. 14, 1962 Supersedes Sept. 4, 1962.

Printed in U.S.A.

Prices and specifications subject to change without notice.

Right and left part numbers are on same line,

first number is right, second number is left.

\* Indicates change or addition.

TRIM CODE	MODEL	MATERIAL			COLOR	SED.	4D.	SUB.	SP. CL. CP.	CV. CP.
		Cloth	Vinyl	Leather						
801	L1-L	★	★	-	Blue	★	-	-	-	-
803	L1-L	★	★	-	Tan	★	-	-	-	-
805	L1-L	★	★	-	Red	★	-	-	-	-
898	L1-L	★	★	-	Turquoise	★	-	-	-	-
851	L1-L	-	★	-	Blue	-	-	★	-	-
853	L1-L	-	★	-	Tan	-	-	★	-	-
855	L1-L	-	★	-	Red	-	-	★	-	-
858	L1-L	-	★	-	Turquoise	-	-	★	-	-
871	L1-L	-	★	-	Blue	★	-	-	-	-
873	L1-L	-	★	-	Tan	★	-	-	-	-
875	L1-L	-	★	-	Red	★	-	-	-	-
894	L1-L	-	★	-	Gray	★	-	-	-	-
831	L1-H	★	★	-	Blue	★	-	-	-	-
833	L1-H	★	★	-	Tan	★	-	-	-	-
835	L1-H	★	★	-	Red	★	-	-	-	-
838	L1-H	★	★	-	Turquoise	★	-	-	-	-
871	L1-H	-	★	-	Blue	★	-	★	-	★
873	L1-H	-	★	-	Tan	★	-	★	-	★
875	L1-H	-	★	-	Red	★	-	★	-	★
878	L1-H	-	★	-	Turquoise	-	-	★	-	★
891	L1-P	-	★	-	Blue	-	-	-	★	★
893	L1-P	-	★	-	Tan	-	-	-	★	★
895	L1-P	-	★	-	Red	-	-	-	★	★
898	L1-P	-	★	-	Turquoise	-	-	-	★	★
501	D1-L, D2-L	★	★	-	Blue	★	-	-	-	-
503	D1-L, D2-L	★	★	-	Tan	★	-	-	-	-
505	D1-L, D2-L	★	★	-	Red	★	-	-	-	-
508	D1-L, D2-L	★	★	-	Turquoise	★	-	-	-	-
601	D1-L, D2-L	-	★	-	Blue	-	-	★	-	-
603	D1-L, D2-L	-	★	-	Tan	-	-	★	-	-
605	D1-L, D2-L	-	★	-	Red	-	-	★	-	-
608	D1-L, D2-L	-	★	-	Turquoise	-	-	★	-	-
611	D1-L, D2-L	-	★	-	Blue	★	-	-	-	-
613	D1-L, D2-L	-	★	-	Tan	★	-	-	-	-
694	D1-L, D2-L	-	★	-	Gray	★	-	-	-	-
521	D1-M, D2-M	★	★	-	Blue	★	★	-	★	★
523	D1-M, D2-M	★	★	-	Tan	★	★	-	★	★
525	D1-M, D2-M	★	★	-	Red	★	★	-	★	★
526	D1-M, D2-M	★	★	-	Alabaster & Black	★	★	-	★	★
528	D1-M, D2-M	★	★	-	Turquoise	★	★	-	★	★
621	D1-M, D2-M	-	★	-	Blue	★	-	★	-	-
623	D1-M, D2-M	-	★	-	Tan	-	-	★	-	-
625	D1-M, D2-M	-	★	-	Red	-	-	★	-	-
626	D1-M, D2-M	-	★	-	Alabaster & Black	-	-	★	-	-
628	D1-M, D2-M	-	★	-	Turquoise	-	-	★	-	-
541	D1-H, D2-H	★	★	-	Blue	★	-	-	-	-
543	D1-H, D2-H	★	★	-	Tan	★	-	-	-	-
545	D1-H, D2-H	★	★	-	Red	★	-	-	-	-
546	D1-H, D2-H	★	★	-	Alabaster & Black	★	-	-	-	-
548	D1-H, D2-H	★	★	-	Turquoise	★	-	-	-	-
641	D1-H, D2-H	-	★	-	Blue	★	★	-	★	-
643	D1-H, D2-H	-	★	-	Tan	★	★	-	★	-
645	D1-H, D2-H	-	★	-	Red	★	★	-	★	-
646	D1-H, D2-H	-	★	-	Alabaster & Black	★	★	-	★	-
648	D1-H, D2-H	-	★	-	Turquoise	★	★	-	★	-

★ Indicates use as required.

☐ Indicates parts not listed in any previous parts book.  
 Right and left part numbers are on same line,  
 first number is right, second number is left.

Printed in U.S.A.  
 Prices and specifications subject to change without notice.  
 September 4, 1962.

# 1963 PASSENGER CAR PARTS CATALOG

INTERIOR TRIM

TRIM CODE	MODEL	MATERIAL			COLOR	SED.	4D.	SUB.	SP. CL. CP.	CV. CP.
		Cloth	Vinyl	Leather						
651	D2-P	-	★	-	Blue	-	-	-	★	★
653	D2-P	-	★	-	Tan	-	-	-	★	★
655	D2-P	-	★	-	Red	-	-	-	★	★
656	D2-P	-	★	-	Alabaster & Black	-	-	-	★	★
658	D2-P	-	★	-	Turquoise	-	-	-	★	★
694	D1, D2	-	★	-	Gray	★	★	-	-	-
561	A3-E	★	★	-	Blue	★	-	★	-	-
563	A3-E	★	★	-	Tan	★	-	★	-	-
565	A3-E	★	★	-	Red	★	-	★	-	-
568	A3-E	★	★	-	Turquoise	★	-	★	-	-
571	A3-L	★	★	-	Blue	-	-	-	★	-
572	A3-L	★	★	-	Green	-	-	-	★	-
573	A3-L	★	★	-	Tan	-	-	-	★	-
575	A3-L	★	★	-	Red	-	-	-	★	-
578	A3-L	★	★	-	Turquoise	-	-	-	★	-
584	A3-L	★	★	-	Gray	★	-	-	-	-
671	A3-L	-	★	-	Blue	-	★	★	-	★
672	A3-L	-	★	-	Green	-	★	★	-	★
673	A3-L	-	★	-	Tan	-	★	★	-	★
675	A3-L	-	★	-	Red	-	★	★	-	★
678	A3-L	-	★	-	Turquoise	-	★	★	-	★
684	A3-L	-	★	-	Gray	★	-	-	-	-

## NOTES

---



---



---



---



---



---



---



---



---



---



---



---



---



---



---



---



---



---



---



---



---



---

★ Indicates use as required.  
 ☐ Indicates parts not listed in any previous parts book.  
 Jan. 3, 1964 Supersedes Jan. 25, 1963.

Printed in U.S.A.  
 Prices and specifications subject to change without notice.  
 Right and left part numbers are on same line,  
 first number is right, second number is left.  
 \* Indicates change or addition.

CODE	REMARKS	PER CAR	SED.	SP. 4 D.	SUB.	SP. CL. CP.	CV. CP.
<p>NOTE: RIGHT HAND AND LEFT HAND PARTS LISTED ON THE SAME LINE. Whenever right and left hand parts are identified by consecutive part numbers, they will be listed as in the following example:                      PANEL, Door Trim 2083 344-5                      Interpreted, this indicates that Panel, right is Part No. 2083 344 and Panel, left is Part No. 2083 345.</p>							
23-70-5	COVER, Wheelhouse Second Seat Back Hinge Bracket A3E, A3L (codes 561, 671) (blue) (codes 563-673) (tan)	1 1	----	----	*2180 202-3 2180 098-9		
	COVER, Second Seat Back Hinge Bracket A3-L (code 671) (code 672) (code 673) A3-L (codes 565, 675) (codes 568, 678)	1 1 1 1 1	----	----	*2180 202-3 E2181 368-9 *2180 098-9 E2181 370-1 E2181 372-3		
23-70-6	COVER, Second Seat Back Hinge (paint as required) A3-L	1	----	----	2094 882-3		
23-71-1	COVER, Front Console (carpet) D2-P (code 651) (code 653) (code 655) (code 656) (code 658)	1 1 1 1 1	----	----	----	2431 970-1 2431 972-3 2431 974-5 2431 976-7 2431 978-9	2431 970-1 2431 972-3 2431 974-5 2431 976-7 2431 978-9
23-76-3	ARM REST, Front Door L1-L, L1-H (codes 801, 831, 851, 871) (blue) (codes 803, 833, 853, 873) (tan) (codes 805, 835, 855, 875) (red) (codes 808, 838, 858, 878) (turquoise) (code 891) (blue) (code 899) (gray)	2 2 2 2 1 2	2413 934 2413 936 2413 938 2413 939 ----	----	2413 934 2413 936 2413 938 2413 939 ----	2428 970-1 2428 974-5 2428 976-7 2428 978-9 2428 970-1	2413 934 2413 936 2413 938 2413 939 2428 970-1
	D1, D2 (codes 501, 601, 611) (small) (blue) (codes 521, 541, 621, 641, 651) (large) (blue) (codes 523, 543, 623, 643, 653) (tan) (codes 525, 545, 625, 645, 655) (red) (codes 526, 546, 626, 646, 656) (alabaster)	2 1 1 1 1	2413 934 2428 970-1 2428 974-5 2428 976-7 2428 978-9	----	2413 934 2428 970-1 2428 974-5 2428 976-7 2428 978-9	2428 970-1 2428 970-1 2428 974-5 2428 976-7 2428 978-9	2428 970-1 2428 970-1 2428 974-5 2428 976-7 2428 978-9
	(codes 528, 548, 628, 648, 658, 899) (large) (turquoise) (codes 508, 608) (small) (turquoise) (code 656) (black) (codes 503, 603, 613) (tan) (codes 505, 605) (red) (codes 594, 694, 699) (gray)	1 2 1 2 2 2	2428 980-1 2413 939 2413 936 2413 938 2413 944	2428 980-1 ----	2428 980-1 2413 939 2413 936 2413 938	2428 980-1 ----	2428 980-1 2413 939 2428 982-3

★ Indicates use as required.  
 □ Indicates parts not listed in any previous parts book.  
 Right and left part numbers are on some line, first number is right, second number is left.  
 \* Indicates change or addition.

Printed in U.S.A.  
 Prices and specifications subject to change without notice.  
 Jan. 3, 1964 Supersedes Jan. 25, 1963.

## 1963 PASSENGER CAR PARTS CATALOG

INTERIOR TRIM

CODE	REMARKS	PER CAR	SED.	SP. 4 D.	SUB.	SP. CL. CP.	CV. CP.
23-76-3	ARM REST, Front Door - Cont'd A3E						
	(code 561) (blue)	2	*2413 934	----	2413 934		
	(code 563) (tan)	2	*2413 936	----	2413 936		
	(codes 584, 684) (gray)	2	2413 937				
	(code 565) (red)	2	2413 938	----	2413 938		
	A3-L						
	(codes 571, 671) (blue)	1	2181 252-3	2181 252-3	2181 252-3	2181 252-3	2181 252-3
	(code 572) (green)	1	----	----	----	----	*2428 972-3
	(codes 573, 673) (tan)	1	2181 254-5	2181 254-5	2181 254-5	2181 254-5	2181 254-5
	(codes 575, 675) (red)	1	2428 976-7	2428 976-7	2428 976-7	2428 976-7	2428 976-7
	(codes 578, 678) (turquoise)	1	2181 256-7	2181 256-7	2181 256-7	2181 256-7	2181 256-7
	(codes 584, 684) (gray)	1	2181 024-5				
23-76-16	NUT, Arm Rest to Panel L1, D1, D2, A3-L	4	1280 134	1280 134	1280 134	1280 134	1280 134
23-76-18	ARM REST, Front Seat Back Center D1, D2						
	(codes 541, 641)	1	2414 359	2414 359	----	2414 359	2414 359
	(codes 543, 643)	1	2414 361	2414 361	----	2414 361	2414 361
	(codes 545, 645)	1	2414 362	2414 362	----	2414 362	2414 362
	(codes 546, 646)	1	2414 363	2414 363	----	2414 363	2414 363
	(codes 548, 648)	1	2431 097	2431 097	----	2431 097	2431 097
23-76-27	HOOK, Front Seat Center Arm Rest Retainer L1-P, D1, D2	1	1918 568	1918 568	1918 568	1918 568	1918 568
23-76-28	BAR, Front Seat Center Arm Rest Lock D1-H, D2-H	1	2270 102	2270 102	2270 102	2270 102	2270 102
23-76-34	COVER, Front Seat Back Center Arm Rest D1, D2						
	(codes 541, 641)	1	2414 354	2414 354	----	2414 354	2414 354
	(codes 543, 643)	1	2414 356	2414 356	----	2414 356	2414 356
	(codes 545, 645)	1	2414 357	2414 357	----	2414 357	2414 357
	(codes 546, 646)	1	2414 358	2414 358	----	2414 358	2414 358
	(codes 548, 648)	1	2431 096	2431 096	----	2431 096	2431 096
23-76-59	ARM REST, Rear Door L1-L, L1-H						
	(codes 801, 831, 851, 871) (blue)	2	2413 934	----	2413 934		
	(codes 803, 833, 853, 873)(tan)	2	2413 936	----	2413 936		
	(codes 805, 835, 855, 875)(red)	2	2413 938	----	2413 938		
	(codes 808, 838, 858, 878) (turquoise)	2	2413 939	----	2413 939		
	(codes 894, 899) (gray)	2	2413 944				
	D1, D2						
	(codes 501, 521, 601, 611, 621) (small) (blue)	2	2413 934	----	2413 934		
	(codes 541, 641) (large) (blue)	2	2428 970-1	2428 970-1			
	(codes 503, 523, 603, 613, 623) (small) (tan)	2	2413 936	----	2413 936		
	(codes 505, 525, 605, 625)(red)	2	2413 938	----	2413 938		
	(codes 508, 528, 608, 628) (small) (turquoise)	2	2413 939	----	2413 939		
	(codes 526, 626) (small) (alabaster)	2	2413 940	----	2413 940		

★ Indicates use as required.

☐ Indicates parts not listed in any previous parts book.

Jan. 3, 1964 Supersedes Dec. 14, 1962.

Printed in U.S.A.

Prices and specifications subject to change without notice.

Right and left part numbers are on same line,

first number is right, second number is left.

\* Indicates change or addition.

CODE	REMARKS	PER CAR	SED.	SP. 4 D.	SUB.	SP. CL. CP.	CV. CP.
23-76-59	ARM REST, Rear Door - Cont'd D1, D2 (codes 543, 643) (large) (tan)	2	2428 974-5	----	2428 974-5		
	(codes 546, 646) (large) (alabaster)	2	2428 978-9	2428 978-9			
	(codes 545, 645) (large) (red)	2	2428 976-7	2428 976-7			
	(codes 548, 648) (large) (turquoise)	2	2428 980-1	2428 980-1			
	(codes 594, 694, 699) (gray)	2	2413 944				
	A3-E (blue)	2	*2413 934	----	*2413 934		
	(tan)	2	*2413 936	----	*2413 936		
	(red)	2	*2413 938	----	*2413 938		
	(turquoise)	2	*2413 943	----	*2413 943		
	A3-L (blue)	1	*2428 976-7	----	*2428 976-7		
(green)	1	*2428 972-3	*2428 972-3	*2428 972-3			
(tan)	1	*2428 974-5	----	*2428 974-5			
(red)	1	*2428 976-7	*2428 976-7	*2428 976-7			
23-76-66	ARM REST, Rear Quarter L1-L, L1-H (codes 801, 831, 891) (blue)	2	2413 934	----	2413 934		
	(codes 803, 833, 893) (tan)	2	2413 936	----	2413 936		
	(codes 805, 835, 895) (red)	2	2413 938	----	2413 938		
	(codes 808, 838, 898) (turquoise)	2	2413 939	----	2413 939		
	D1, D2 (codes 501, 521, 641, 651)(blue)	2	2413 934	----	2413 934		
	(codes 503, 523, 643, 653)(tan)	2	2413 936	----	2413 936		
	(codes 505, 525, 645, 655)(red)	2	2413 938	----	2413 938		
	(code 526) (alabaster)	2	2413 940	----	2413 940		
	(codes 508, 528, 648, 658) (turquoise)	2	2413 939	----	2413 939		
	(code 656) (black)	2	----	----	2413 941		
(codes 594, 694) (gray)	2	2413 944					
A3	(blue)	2	*2413 934	----	*2413 934	*2181 248	E2137 636-7
	(green)	2	*2413 935	----			E2137 638-9
	(tan)	2	*2413 936	----	*2413 936	*2181 249	E2137 640-1
	(red)	2	*2413 938	----	*2413 938	*2413 938	E2137 988-9
	(turquoise)	2	*2413 943	----	*2413 943	*2181 250	E2137 642-3
23-76-80	NUT, Quarter Arm Rest to Panel L1, D1, A3-L	4	1280 134	----	1280 134		
23-79-3	CARPET, Front Floor L1 (codes 801, 831, 851, 871)(blue)	1	2299 451	----	2299 451		
	(codes 803, 833, 853, 873)(tan)	1	2299 452	----	2299 452		
	(codes 805, 835, 855, 875)(red)	1	2299 453	----	2299 453		
	(codes 808, 838, 858, 878) (blue green)	1	2299 454	----	2299 454	----	*2299 454
	L1-P (code 891) (blue)	1	----	----	----	2421 534	*2421 534
(code 893) (tan)	1	----	----	----	2421 535	*2421 535	
(code 895) (red)	1	----	----	----	2421 536	*2421 536	
(code 898) (turquoise)	1	----	----	----	2421 537	*2421 537	
D1, D2	(blue)	1	*2299 473	*2299 473	*2299 473	*2299 473	*2299 473
	(tan)	1	*2299 475	*2299 475	*2299 475	*2299 475	*2299 475

★ Indicates use as required.

E Indicates parts not listed in any previous parts book.

Right and left part numbers are on same line,

first number is right, second number is left.

\* Indicates change or addition.

Prices and specifications subject to change without notice.

Jan. 3, 1964 Supersedes Jan. 25, 1963.

# 1963 PASSENGER CAR PARTS CATALOG

INTERIOR TRIM

CODE	REMARKS	PER CAR	SED.	SP. 4 D.	SUB.	SP. CL. CP.	CV. CP.
23-79-3	CARPET, Front Floor - Cont'd						
	D1, D2						
	(red)	1	*2299 476	*2299 476	*2299 476	*2299 476	*2299 476
	(black)	1	*2299 477	*2299 477	*2299 477	*2299 477	*2299 477
	(turquoise)	1	*2299 478	*2299 478	*2299 478	*2299 478	*2299 478
	D2 (use with floor mounted shift)						
	(blue)	1	2448 239	2448 239	2448 239	2448 239	2448 239
	(tan)	1	2448 241	2448 241	2448 241	2448 241	2448 241
	(red)	1	2448 242	2448 242	2448 242	2448 242	2448 242
	(black)	1	2448 243	2448 243	2448 243	2448 243	2448 243
	(turquoise)	1	2448 244	2448 244	2448 244	2448 244	2448 244
	A3						
	(blue)	1	2299 491	2299 491	2299 491	2299 491	2299 491
	(green)	1	2299 492	2299 492	2299 492	2299 492	2299 492
(tan)	1	2299 493	2299 493	2299 493	2299 493	2299 493	
(red)	1	2299 494	2299 494	2299 494	2299 494	2299 494	
(turquoise)	1	2299 495	2299 495	2299 495	2299 495	2299 495	
A3 (use with floor mounted shift)							
(blue)	1	*2179 433	*2179 433	*2179 433	*2179 433	*2179 433	
(green)	1	*2179 434	*2179 434	*2179 434	*2179 434	*2179 434	
(tan)	1	*2179 435	*2179 435	*2179 435	*2179 435	*2179 435	
(red)	1	*2181 261	*2181 261	*2181 261	*2181 261	*2181 261	
(turquoise)	1	*2179 437	*2179 437	*2179 437	*2179 437	*2179 437	
23-79-33	CARPET, Rear Floor						
	(blue)	1	2299 456	----	2299 456	2448 119	*2448 119
	(tan)	1	2299 457	----	2299 457	2448 120	*2448 120
	(red)	1	2299 458	----	2299 458	2448 121	*2448 121
	(turquoise)	1	2299 459	----	2299 459	2448 122	*2448 122
	D1, D2						
	(blue)	1	2299 479	2299 479	----	2299 479	2299 479
	(tan)	1	2299 480	2299 480	----	2299 480	2299 480
	(red)	1	2299 481	2299 481	----	2299 481	2299 481
	(turquoise)	1	2299 483	2299 483	----	2299 483	2299 483
	(black)	1	2299 482	2299 482	----	2299 482	2299 482
	(blue)	1	----	----	2299 484		
	(tan)	1	----	----	2299 486		
	(red)	1	----	----	2299 487		
(black)	1	----	----	2299 488			
(turquoise)	1	----	----	2299 489			
(axle kick-up front trim panel) (embossed hardboard) (paint as required) (black)	1	----	----	2413 413			
(rear floor pan insert) (vinoleum) (codes 601, 621)							
(blue)	1	----	----	2297 579			
(codes 603, 623) (tan)	1	----	----	2297 580			
(codes 605, 625) (red)	1	----	----	⊠1801 TR6			
(code 626) (black)	1	----	----	2297 582			
(codes 608, 628) (turquoise)	1	----	----	2297 583			
(rear floor pan cover insert) (vinoleum) (codes 601, 621)							
(blue)	1	----	----	2297 585			
(codes 602, 623) (tan)	1	----	----	2297 586			
(codes 605, 625) (red)	1	----	----	⊠1802 TR6			
(code 626) (black)	1	----	----	2297 588			
(codes 608, 628) (turquoise)	1	----	----	2297 589			
(center floor pan cover insert) (vinoleum) (codes 601, 621)							
(blue)	1	----	----	2297 573			
(codes 603, 623) (tan)	1	----	----	2297 574			
(codes 605, 625) (red)	1	----	----	⊠1800 TR6			
(code 626) (black)	1	----	----	2297 576			
(codes 608, 628) (turquoise)	1	----	----	2297 577			

★ Indicates use as required.

⊠ Indicates parts not listed in any previous parts book.

Jan. 3, 1964 Supersedes Jan. 25, 1963.

Printed in U.S.A.

Prices and specifications subject to change without notice.

Right and left part numbers are on same line,  
first number is right, second number is left.

\* Indicates change or addition.



CODE	REMARKS	PER CAR	SED.	SP. 4 D.	SUB.	SP. CL. CP.	CV. CP.
23-79-33	CARPET, Rear Floor-Cont'd A3 (blue) (green) (tan) (red) (turquoise) (under body axle kick-up rear trim panel carpet) (codes 561, 563, 565, 568, 671, 672, 673, 675, 678) (black)	1 1 1 1 1 1	*2421 522 *2421 523 *2421 524 *2421 525 *2421 526	*2421 522 *2421 523 *2421 524 *2421 525 *2421 526	*2421 617 E2448 234 *2421 518 *2421 519 E2448 235	*2421 522 *2421 523 *2421 524 *2421 525 *2421 526	*2421 522 *2421 523 *2421 524 *2421 525 *2421 526
	A3-L (second seat back to rear floor pan insert)(vinoleum) (codes 561, 671) (blue) (code 672) (green) (codes 563, 673) (tan) (codes 565, 675) (red) (codes 568, 678) (turquoise) (rear floor pan cover insert) (vinoleum) (codes 561, 671) (blue) (code 672) (green) (codes 563, 673) (tan) (code 565, 675) (red) (codes 568, 678) (turquoise)	1 1 1 1 1 1 1 1 1 1	----- ----- ----- ----- ----- ----- ----- ----- ----- -----	----- ----- ----- ----- ----- ----- ----- ----- ----- -----	*2179 533 E2180 835 2181 377 *2181 378 *2181 379 *2181 380 *2180 836 2181 361 *2181 374 *2181 375 *2181 376		
23-79-62	INSERT, Second Seat Cushion Panel A3 (vinoleum) (codes 561, 671) (code 672) (codes 563, 673) (codes 565, 675) (codes 568, 678)	1 1 1 1 1	----- ----- ----- ----- -----	----- ----- ----- ----- -----	2180 831 2181 385 2181 386 2181 387 2181 388		
23-79-79	INSERT, Tailgate Panel Cover D1, D2 (vinoleum) (codes 601, 621) (blue) (codes 603, 623) (tan) (codes 605, 625) (red) (code 626) (black) (codes 608, 628) (turquoise)	1 1 1 1 1	----- ----- ----- ----- -----	----- ----- ----- ----- -----	*2297 555 2297 556 E1803 TR6 2297 558 2297 559		
	A3 (vinoleum) (codes 561, 671) (code 672) (codes 563, 673) (codes 565, 675) (codes 568, 678)	1 1 1 1 1	----- ----- ----- ----- -----	----- ----- ----- ----- -----	2180 837 2181 381 2181 382 2181 383 2181 384		
23-81-3	HANDLE, Rear Door Pull-To D1, D2	1	1697 413				
23-81-8	SPACER, Rear Door Pull-To D1, D2	2	1964 579				
23-82-30	HOOK, Coat Hanger L1, D1, D2, A3 Screw	2 ★	2165 837 148 095	2165 837 148 095	2165 837 148 095	2165 837 148 095	
23-82-39	BRACKET, Coat Hook Support L1, D1, D2 A3	2 2	*2481 175 1964 072	*2481 175 1963 287	*2481 175 -----	*2481 175 1963 287	
23-84-3	PAD, Instrument Panel Trim L1-L, L1-H, L1-P (codes 801, 831, 851, 871, 891) (blue)	1	2432 682	-----	2432 682	2432 682	2432 682

★ Indicates use as required.  
E Indicates parts not listed in any previous parts book.  
Right and left part numbers are on same line, first number is right, second number is left.  
\* Indicates change or addition.

Printed in U.S.A.  
Prices and specifications subject to change without notice.  
Jan. 3, 1964 Supersedes Jan. 25, 1963.

# 1963 PASSENGER CAR PARTS CATALOG

INTERIOR TRIM

CODE	REMARKS	PER CAR	SED.	SP. 4 D.	SUB.	SP. CL. CP.	CV. CP.
23-84-3	PAD, Instrument Panel Trim - Cont'd L1-L, L1-H, L1-P (codes 803, 833, 853, 873, 893) (tan)	1	2432 685	----	2432 685	2432 685	2432 685
	(codes 805, 835, 855, 875, 895) (red)	1	2413 028	----	2413 028	2413 028	
	(code 899) (gray)	1	2432 684				
	(codes 808, 838, 858, 878, 898) (turquoise)	1	2432 686	----	2432 686	2432 686	2432 686
	D1, D2, LHD. (codes 501, 521, 541, 601, 611, 621, 641, 651) (blue)	1	2432 141	2432 141	2432 141	2432 141	2432 141
	(codes 503, 523, 543, 603, 613, 623, 643, 653) (tan)	1	2432 142	2432 142	2432 142	2432 142	2432 142
	(codes 505, 525, 545, 605, 625, 645, 655) (red)	1	2432 143	2432 143	2432 143	2432 143	2432 143
	(codes 508, 528, 548, 608, 628, 648, 658) (turquoise)	1	2432 145	2432 145	2432 145	2432 145	2432 145
	(codes 526, 546, 626, 646, 656, 694) (black)	1	*2432 144	2432 144	*2432 144	*2432 144	*2432 144
A3	(blue)	1	2180 988	2180 988	2180 988	2180 988	2180 988
	(tan)	1	2180 990	2180 990	2180 990	2180 990	2180 990
	(red)	1	2180 991	2180 991	2180 991	2180 991	2180 991
	(green)	1	2180 989	2180 989	2180 989	2180 989	2180 989
	(turquoise)	1	2180 992	2180 992	2180 992	2180 992	2180 992
	(black)	1	2181 007				
	(fastener)	7	6008 222	6008 222	6008 222	6008 222	6008 222
23-86-3	HEADLINING and LISTINGS L1 (codes 801, 831, 851, 871, 891) (blue)	1	2431 289	----	2429 343	2431 289	
	(codes 803, 805, 833, 835, 853, 855, 873, 875, 893, 895) (alabaster)	1	2431 290	----	2429 346	2431 290	
	(codes 808, 838, 858, 878, 898) (turquoise)	1	2431 291	----	2429 347	2431 291	
	D1, D2 (codes 501, 521, 541, 611, 621, 641) (blue)	1	2429 506	----	----	2429 506	
	(codes 503, 505, 523, 525, 526, 543, 545, 546, 613, 623, 643, 645, 646) (alabaster)	1	2429 507	----	----	2429 507	
	(codes 508, 528, 548, 648) (turquoise)	1	2429 510	----	----	2429 510	
	(codes 594, 694) (gray)	1	2429 508	----	----	2429 508	
	D1-L, D2-L (No. 1)	1	----	----	2273 461		
	(No. 2)	1	----	----	2413 905		
	(No. 3)	1	----	----	2273 463		
	(No. 4)	1	----	----	2273 464		
	(No. 5)	1	----	----	2273 465		
	(No. 6)	1	----	----	2273 466		
	(No. 7)	1	----	----	2273 467		
	D1-M, D2-M (No. 1)	1	----	----	2428 948		
	(No. 2)	1	----	----	2428 949		
	(No. 3)	1	----	----	2428 950		
	(No. 4)	1	----	----	2428 951		
	(No. 5)	1	----	----	2428 952		
	(No. 6)	1	----	----	2428 953		
	(No. 7)	1	----	----	2428 954		

★ Indicates use as required.

⊔ Indicates parts not listed in any previous parts book.

Jan. 3, 1964 Supersedes Dec. 14, 1962.

Prices and specifications subject to change without notice.

Right and left part numbers are on same line,  
first number is right, second number is left.

\* Indicates change or addition.

Printed in U.S.A.

CODE	REMARKS	PER CAR	SED.	SP. 4 D.	SUB.	SP. CL. CP.	CV. CP.
23-86-3	HEADLINING and LISTINGS-Cont'd D1-H, D2-H, D2-P						
	(No. 1)	1	----	2429 078	----	2429 078	
	(No. 2)	1	----	2429 079	----	2429 079	
	(No. 3)	1	----	2429 080	----	2429 080	
	(No. 4)	1	----	2429 081	----	2429 081	
	(No. 5)	1	----	2429 082	----	2429 082	
	(extension) (w/Mldg.)	1	----	*2429 084-5	----	*2429 084-5	
	(w/o Mldg.)	1	----	2432 292-3	----	2432 292-3	

NOTE: When Ordering the Following White Headlining Panels Please Include Sample.

A3-E (white)							
(code 561)	1	2137 606					
(codes 563, 565)	1	*2137 608					
(code 568)	1	2137 609					
(codes 561, 563, 565, 568)							
(No. 1)	1	----	----	2181 524			
(No. 2)	1	----	----	2181 525			
(No. 3)	1	----	----	2181 526			
(No. 4)	1	----	----	2176 828			
(No. 5)	1	----	----	2176 829			
(No. 6)	1	----	----	2176 830			
(No. 7)	1	----	----	2176 831			
A3-L (white)							
(codes 571, 578, 671, 678)							
(No. 1)	1	----	*2181 062	----		*2181 062	
(No. 2)	1	----	2181 064	----		2181 064	
(No. 3)	1	----	2181 066	----		2181 066	
(No. 4)	1	----	2181 068	----		2181 072	
(No. 4 extension)	1	----	----	----		2181 074-5	
(No. 5)	1	----	2181 070	----			
(codes 571, 572, 573, 575, 578, 671, 672, 673, 675, 678)							
(No. 1)	1	----	*2181 063	----		*2181 063	
(No. 2)	1	----	2181 065	----		2181 065	
(No. 3)	1	----	2181 067	----		2181 067	
(No. 4)	1	----	2181 069	----		2181 073	
(No. 4 extension)	1	----	----	----		2181 078-9	
(No. 5)	1	----	2181 071	----			
A3-L							
(code 571) (blue)	1	*2137 606					
(code 572) (green)	1	*2137 607					
(codes 573, 575) (alabaster)	1	*2137 608					
(code 578) (turquoise)	1	*2137 609					
(codes 584, 684) (gray)	1	*2137 662					

A3-L (white)

NOTE: When Ordering the Following White Headlining Panels Please Include Sample.

(codes 671, 678)							
(No. 1)	1	----	----	2181 080			
(No. 2)	1	----	----	2181 082			
(No. 3)	1	----	----	2181 084			
(No. 4)	1	----	----	2181 086			
(No. 5)	1	----	----	*2181 090			
(No. 6)	1	----	----	*2181 088			
(No. 7)	1	----	----	2181 092			

★ Indicates use as required.  
 ☐ Indicates parts not listed in any previous parts book.  
 Right and left part numbers are on same line,  
 first number is right, second number is left.  
 \* Indicates change or addition.

## 1963 PASSENGER CAR PARTS CATALOG

INTERIOR TRIM

CODE	REMARKS	PER CAR	SED.	SP. 4 D.	SUB.	SP. CL. CP.	CV. CP.
23-86-3	HEADLINING and LISTINGS-Cont'd A3-L (white)						
	NOTE: When Ordering the Following White Headlining Panels Please include Sample)						
	(codes 671, 672, 673, 675, 678)						
	(No. 1)	1	----	----		*2181 081	
	(No. 2)	1	----	----		2181 083	
	(No. 3)	1	----	----		2181 085	
	(No. 4)	1	----	----		2181 087	
	(No. 5)	1	----	----		*2181 091	
	(No. 6)	1	----	----		*2181 089	
	(No. 7)	1	----	----		2181 093	
23-86-10	BOW, Roof Support						
	L1	3	----	----		*2243 251	
	(Nos. 1 and 2)	2	*2242 504	----		*2242 504	
	D1, D2						
	(No. 1)	1	2166 267	2166 267		2166 267	2166 267
	(No. 2)	1	----	----		*2166 268	
	(Nos. 2 and 3)	2	*2166 268	*2166 268		----	*2166 268
	(Nos. 3 and 4)	1	----	----		2166 269	
	A3						
	(No. 1)	1	1954 682	1954 682		1954 682	1954 682
	(No. 2)(w/dome lamp hsg.)	1	1963 606	1963 606		1961 243	
	(No. 3)	1	----	----		1961 244	
	(No. 4)	1	----	----		1961 244	
23-86-13	FILLER, Air Conditioning Roof Evaporator Unit Trim						
	A3	1	----	----		1914 582	
23-86-14	PAD, Air Conditioning Roof Evaporator Unit Trim						
	A3	1	----	----		2171 580	
23-86-16	SUPPORT, Roof Inside Finish Panel on Roof Rail						
	D1, D2, A3	14	----	*2216 461		----	*2216 461
	(to rear window frame)	3	----	*2419 925		----	*2419 925
	(fastener)	12	----	6000 922		----	6000 922
23-86-19	STRIP, Headlining Retaining						
	L1 Front	1	2242 996-7	----		2423 636-7	
	Rear	1	2244 348-9	----		2423 638-9	2244 346-7
	D1, D2						
	Front	1	2167 228-9	*2167 228-9		----	*2167 228-9
	Rear	1	2255 430-1	----		----	
	Side Front	1	----	----		2251 806-7	
	Side Rear	1	----	----		2251 446-7	
	Rear	1	----	----		2251 448	
	Corner Rear	1	----	----		2251 444-5	
	A3	1	1954 804-5	----		----	
23-86-24	RETAINER, Roof Inside Finish Moulding						
	D1, D2						
	(No. 1)	1	----	2419 561		2292 162	2419 561
	(No. 2)	1	----	*2419 563		2292 163	*2419 563
	(No. 3)	1	----	2419 563		2292 164	2419 563
	(No. 4)	1	----	2419 564		2292 165	2419 564
	(No. 5)	1	----	----		2292 166	
	(No. 6)	1	----	----		2292 167	
	(Extension)	2	----	2419 545		----	2419 545

★ Indicates use as required.

☐ Indicates parts not listed in any previous parts book.

Jan. 3, 1964 Supersedes Dec. 14, 1962.

Printed in U.S.A.

Prices and specifications subject to change without notice.

Right and left part numbers are on same line,  
first number is right, second number is left.

\* Indicates change or addition.

CODE	REMARKS	PER CAR	SED.	SP. 4 D.	SUB.	SP. CL. CP.	CV. CP.
23-86-24	RETAINER, Roof Inside Finish Moulding - Cont'd A3 (No. 1) (No. 2) (No. 3) (No. 4) (No. 5) (No. 6)	1 1 1 1 1 1	----- ----- ----- ----- ----- -----	*2440 093 2440 093 2440 093 2440 094 ----- -----	*2086 143 2086 142 2086 145 2086 146 2086 146 2086 148	*2440 093 2440 093 2440 093 2440 094 ----- -----	
23-86-35	MOULDING, Roof Inside Finish Panel D1-L, D2-L, D1-M, D2-M D1-H, D2-H, D2-P (No. 1) (No. 2) (No. 3) (No. 4 thru No. 6) (Extension) A3 (No. 1 thru No. 6)	* 1 1 1 1 1 *	----- ----- ----- ----- ----- ----- E2440 144	----- 2292 372 2292 374 2292 376 ----- 2419 856-7 -----	2292 377 E2440 144 E2440 144 E2440 144 E2440 144 ----- E2440 144	2292 377 2292 372 2292 374 2292 376 E2440 144 E2440 144 2419 856-7 E2440 144	
23-86-36	CAP, Roof Inside Finish Moulding D1-L, D2-L, D1-M, D2-M D1-H, D2-H D1, D2 (side retainer) A3-L	12 12 1 * 1 6	----- ----- ----- ----- ----- -----	----- ----- ----- 1759 636 1905 450-1 2440 150-1	1759 635 1759 636 2251 808-9 1759 636 1759 636	1759 636 1759 636	
23-86-37	COVER, Roof Inside Finish Panel Joint (white) (alabaster)	2 2	----- -----	----- -----	----- -----	*2181 076 *2181 077	
23-91-6	PANEL, Cowl Trim (paint as required) L1-L, L1-H, L1-P  D1, D2 (codes 501, 521, 541, 601, 611, 621, 641, 651) (blue) (codes 503, 523, 541, 603, 613, 623, 643, 653) (tan) (codes 526, 546, 626, 646) (alabaster) (codes 505, 525, 545, 605, 625, 645, 655) (red) (codes 508, 528, 548, 608, 628, 648, 658) (turquoise) (codes 656, 694) (black) A3 (prime)	1  1 1 1 1 1 1 1 1 1	2297 410-1 ----- 2413 000-1 2413 004-5 2413 008-9 2413 010-1 2413 012-3 2413 006-7 2086 612-3	----- ----- 2413 000-1 2413 004-5 2413 008-9 2413 010-1 2413 012-3 2413 006-7 2086 612-3	2297 410-1 ----- 2413 000-1 2413 004-5 2413 008-9 2413 010-1 2413 012-3 2413 006-7 2086 612-3	----- ----- 2413 000-1 2413 004-5 2413 008-9 2413 010-1 2413 012-3 2413 006-7 2086 612-3	2297 410-1  2413 000-1 2413 004-5 2413 008-9 2413 010-1 2413 012-3 2413 006-7 2086 612-3
23-92-5	PANEL, Door Trim L1-L (2 D.) (code 801) (code 803) (code 805) (code 808)  L1-L (4 D.) (codes 801, 851) Front Rear (codes 803, 853) Front Rear (codes 805, 855) Front Rear	1 1 1 1  1 1 1 1 1 1	2297 468-9 2297 470-1 2297 472-3 2297 474-5  2297 476-7 2297 484-5 2297 478-9 2297 486-7 2297 480-1 2297 488-9	----- ----- ----- -----  ----- ----- ----- ----- ----- -----	2297 476-7 2297 484-5 2297 478-9 2297 486-7 2297 480-1 2297 488-9		

★ Indicates use as required.  
 ☐ Indicates parts not listed in any previous parts book.  
 Right and left part numbers are on same line,  
 first number is right, second number is left.  
 \* Indicates change or addition.

## 1963 PASSENGER CAR PARTS CATALOG

INTERIOR TRIM

CODE	REMARKS	PER CAR	SED.	SP. 4 D.	SUB.	SP. CL. CP.	CV. CP.
23-92-5	PANEL, Door Trim-Cont'd						
	L1-L (4 D.)						
	(codes 808, 858) Front	1	2297 482-3	----	2297 482-3		
	Rear	1	2297 490-1	----	2297 490-1		
	(code 871) Front	1	2297 654-5				
	Rear	1	2297 662-3				
	(code 873) Front	1	2297 656-7				
	Rear	1	2297 664-5				
	(code 875) Front	1	2297 658-9				
	Rear	1	2297 666-7				
	L1-H (4 D.)						
	(code 871) Front	1	2297 654-5	----	2297 654-5		
	Rear	1	2297 662-3	----	2297 662-3		
	(code 873) Front	1	2297 656-7	----	2297 656-7		
	Rear	1	2297 664-5	----	2297 664-5		
	(code 875) Front	1	2297 658-9	----	2297 658-9		
	Rear	1	2297 666-7	----	2297 666-7		
	(code 878) Front	1	----	----	2297 660-1		
	Rear	1	----	----	2297 668-9		
	L1-H (2 D.)						
	(codes 831, 871)	1	*2297 634-5	----	----	----	*2297 634-5
	(codes 833, 873)	1	*2297 636-7	----	----	----	*2297 636-7
	(codes 835, 875)	1	*2297 638-9	----	----	----	*2297 638-9
	(codes 838, 878)	1	*2297 640-1	----	----	----	*2297 640-1
	L1-H (4 D.)						
	(code 831) Front	1	2297 654-5				
	Rear	1	2297 662-3				
	(code 833) Front	1	2297 656-7				
	Rear	1	2297 664-5				
	(code 835) Front	1	2297 658-9				
	Rear	1	2297 666-7				
	(code 838) Front	1	2297 660-1				
	Rear	1	2297 668-9				
	L1-P						
	(code 891)	1	----	----	----	2428 630-1	2428 630-1
	(code 893)	1	----	----	----	2428 632-3	2428 632-3
	(code 895)	1	----	----	----	2428 634-5	2428 634-5
	(code 898)	1	----	----	----	2428 636-7	2428 636-7
	D1-L, D2-L (2 D.)						
	(code 501)	1	2297 938-9				
	(code 503)	1	2297 940-1				
	(code 505)	1	2297 942-3				
	(code 508)	1	2297 944-5				
	(codes 594, 694)	1	2413 768-9				
	D1-L, D2-L (4 D.)						
	(codes 501, 601, 611) Front	1	2297 858-9	----	2297 858-9		
	Rear	1	2297 866-7	----	2297 866-7		
	(codes 503, 603) Front	1	2297 860-1	----	2297 860-1		
	Rear	1	2297 868-9	----	2297 868-9		
	(codes 505, 605) Front	1	2297 862-3	----	2297 862-3		
	Rear	1	2297 870-1	----	2297 870-1		
	(codes 508, 608) Front	1	2297 864-5	----	2297 864-5		
	Rear	1	2297 872-3	----	2297 872-3		
	(codes 594, 694) Front	1	2413 762-3				
	Rear	1	2413 764-5				
	D1-M, D2-M (2 D.)						
	(code 521)	1	2297 970-1	----	----	2428 600-1	
	(code 523)	1	2297 972-3	----	----	2428 602-3	
	(code 525)	1	2297 974-5	----	----	2428 604-5	
	(code 526)	1	2297 976-7	----	----	2428 606-7	
	(code 528)	1	2297 978-9	----	----	2428 608-9	

★ Indicates use as required.

B Indicates parts not listed in any previous parts book.  
Jan. 3, 1964 Supersedes Jan. 25, 1963.Printed in U.S.A.  
Prices and specifications subject to change without notice.  
Right and left part numbers are on same line,  
first number is right, second number is left.

\* Indicates change or addition.

CODE	REMARKS	PER CAR	SED.	SP. 4 D.	SUB.	SP. CL. CP.	CV. CP.
23-92-5	PANEL, Door Trim-Cont'd D1-M, D2-M (4 D.)						
	(codes 521, 621) Front	1	2297 824-5	----	2297 824-5		
	Rear	1	2297 834-5	----	2297 834-5		
	(codes 523, 623) Front	1	2297 826-7	----	2297 826-7		
	Rear	1	2297 836-7	----	2297 836-7		
	(codes 525, 625) Front	1	2297 828-9	----	2297 828-9		
	Rear	1	2297 838-9	----	2297 838-9		
	(codes 526, 626) Front	1	2297 830-1	----	2297 830-1		
	Rear	1	2297 840-1	----	2297 840-1		
	(codes 528, 628) Front	1	2297 832-3	----	2297 832-3		
	Rear	1	2297 842-3	----	2297 842-3		
	D1-H, D2-H						
	(codes 541, 641) Front	1	2428 702-3	2428 722-3	----	2428 742-3	2428 742-3
	Rear	1	2428 712-3	2428 732-3	----		
	(codes 543, 643) Front	1	2428 704-5	2428 724-5	----	2428 744-5	2428 744-5
	Rear	1	2428 714-5	2428 734-5	----		
	(codes 545, 645) Front	1	2428 706-7	2428 726-7	----	2428 746-7	2428 746-7
	Rear	1	2428 716-7	2428 736-7	----		
	(codes 546, 646) Front	1	2428 708-9	2428 728-9	----	2428 748-9	2428 748-9
	Rear	1	2428 718-9	2428 738-9	----		
	(codes 548, 648) Front	1	2428 710-1	2428 730-1	----	2428 750-1	2428 750-1
	Rear	1	2428 720-1	2428 740-1	----		
	D2-P						
	(code 651)	1	----	----	----	2428 776-7	2428 776-7
	(code 653)	1	----	----	----	2428 778-9	2428 778-9
	(code 655)	1	----	----	----	2428 780-1	2428 780-1
	(code 656)	1	----	----	----	2428 782-3	2428 782-3
	(code 658)	1	----	----	----	2428 784-5	2428 784-5
	A3-E (4 D.)						
	(code 561) Front	1	2181 506-7	----	2181 506-7		
	Rear	1	2181 508-9	----	2181 508-9		
	(code 563) Front	1	2181 510-1	----	2181 510-1		
	Rear	1	2181 512-3	----	2181 512-3		
	(code 565) Front	1	2181 516-7	----	2181 516-7		
	Rear	1	2181 518-9	----	2181 518-9		
	(code 568) Front	1	2181 520-1	----	2181 520-1		
	Rear	1	2181 522-3	----	2181 522-3		
	A3-L (2 D.)						
	(codes 571, 671)	1	----	----	----	2181 152-3	2181 152-3
	(codes 572, 672)	1	----	----	----	2181 156-7	2181 156-7
	(codes 573, 673)	1	----	----	----	2181 160-1	2181 160-1
	(codes 575, 675)	1	----	----	----	2181 164-5	2181 164-5
	(codes 578, 678)	1	----	----	----	2181 168-9	2181 168-9
	A3-L (4 D.)						
	(codes 571, 671) Front	1	2181 102-3	2181 126-7	2181 126-7		
	Rear	1	2181 104-5	2181 128-9	2181 128-9		
	(codes 572, 672) Front	1	2181 106-7	2181 130-1	2181 130-1		
	Rear	1	2181 108-9	2181 132-3	2181 132-3		
	(codes 573, 673) Front	1	2181 110-1	2181 134-5	2181 134-5		
	Rear	1	2181 112-3	2181 136-7	2181 136-7		
	(codes 575, 675) Front	1	2181 114-5	2181 138-9	2181 138-9		
	Rear	1	2181 116-7	2181 140-1	2181 140-1		
	(codes 578, 678) Front	1	2181 118-9	2181 142-3	2181 142-3		
	Rear	1	2181 120-1	2181 144-5	2181 144-5		
	(codes 584, 684) Front	1	2181 194-5				
	Rear	1	2181 196-7				
23-92-8	FASTENER, Quarter, Front or Rear Trim Panel L1, D1, D2, A3-L	★	975 633	975 633	----	975 633	975 633

★ Indicates use as required.  
 ☐ Indicates parts not listed in any previous parts book.  
 Right and left part numbers are on same line,  
 first number is right, second number is left.  
 \* Indicates change or addition.

# 1963 PASSENGER CAR PARTS CATALOG

INTERIOR TRIM

CODE	REMARKS	PER CAR	SED.	SP. 4 D.	SUB.	SP. CL. CP.	CV. CP.
23-96-3	PANEL, Luggage Compartment Front Lining						
	L1	1	2419 639	-----	-----	2419 639	*2440 956
	D1, D2	1	2162 831	2162 831	-----	2162 831	
	A3-L (2 D.)	1	-----	-----	-----	2181 357	2181 358
	A3 (4 D.)	1	2181 356	2181 356	-----		
	FILLER, Luggage Compartment Floor to Quarter						
	D1, D2	1	E2419 866-7				
23-96-8	COVER, Wheelhouse and Lower Quarter Trim (paint as required)						
	D1, D2 (2 seat) Rt.	1	-----	-----	*2297 516		
	Lt.	1	-----	-----	*2432 313		
	(3 seat) Rt.	1	-----	-----	E2432 394		
	Lt.	1	-----	-----	E2432 395		
	A3						
	(codes 561, 671)	1	-----	-----	2180 200-1		
	(code 672)	1	-----	-----	2181 362-3		
	(codes 563, 673)	1	-----	-----	2180 110-1		
	(codes 565, 675)	1	-----	-----	2181 364-5		
	(codes 568, 678)	1	-----	-----	2181 366-7		
	COVER, Rear Sill						
	A3						
	(codes 561, 671)	1	-----	-----	E2434 206		
	(code 672)	1	-----	-----	E2434 212		
	(codes 563, 673)	1	-----	-----	E2434 207		
	(codes 565, 675)	1	-----	-----	E2434 210		
	(codes 568, 678)	1	-----	-----	E2434 211		
	PANEL, Luggage Compartment Side Lining						
	D1, D2	1	2428 988-9	2428 988-9	2428 988-9	2428 988-9	
	A3-L	1	2177 901-2	2177 901-2	-----	2177 901-2	2177 907-8
	EXTENSION, Wheelhouse and Lower Quarter Trim Cover, Rear						
	D1, D2	1	-----	-----	2432 636-7		
23-96-9	CLIP, Luggage Compartment Side Lining Panel						
	A3	6	2165 272	2165 272	-----	2165 272	
23-96-41	RETAINER, Wheelhouse and Lower Quarter Trim Cover (paint as required)						
	D1, D2 Plastic	8	-----	-----	2273 453		
23-99-4	COVER, Center Pillar Trim						
	D1, D2						
	(code 641)	1	-----	2428 646-7			
	(code 643)	1	-----	2428 650-1			
	(code 645)	1	-----	2428 652-3			
	(code 646)	1	-----	2428 654-5			
	(code 648)	1	-----	2428 656-7			
	A3-L						
	(code 671)	1	-----	2179 478-9			
	(code 672)	1	-----	2179 480-1			
	(code 673)	1	-----	2179 482-3			
	(code 675)	1	-----	*2802-3 VT8			
	(code 678)	1	-----	2179 488-9			

★ Indicates use as required.

☐ Indicates parts not listed in any previous parts book.  
Jan. 3, 1964 Supersedes Jan. 25, 1963.

Printed in U.S.A.

Prices and specifications subject to change without notice.

Right and left part numbers are on same line,  
first number is right, second number is left.

\* Indicates change or addition.



CODE	REMARKS	PER CAR	SED.	SP. 4 D.	SUB.	SP. CL. CP.	CV. CP.
23-99-9	RETAINER, Body Rear Lock Pillar Quarter Trim D1, D2	1	----	----	2162 508-9		
23-99-38	PANEL, Rear Upper Pillar Reinforcement L1-L, L1-H (codes 851, 871) (codes 853, 873) (codes 855, 875) (codes 858, 878)	1 1 1 1	----	----	2432 836-7 2432 840-1 *2016-7 TR6 2432 846-7		
23-101-3	PANEL, Rear Quarter Trim L1-L (2 D.) (code 801) (code 803) (code 805) (code 808)	1 1 1 1	2297 460-1 2297 462-3 2297 464-5 2297 466-7				
	(paint as required) L1-L (4 D.) (codes 851, 853, 855, 858) Upper Lower, Right Lower, Left	1 1 1	----	----	2432 710-1 *2012 VT8 2413 747		
	L1-H (2 D.) (code 831) (code 833) (code 835) (code 838)	1 1 1 1	2297 642-3 2297 644-5 2297 646-7 2297 648-9				
	L1 (codes 801, 831, 871) (codes 803, 833, 873) (codes 805, 835, 875) (codes 808, 838)	1 1 1 1	2431 686-7 2431 688-9 2431 690-1 2431 692-3				
	L1-H (code 871) (code 873) (code 875) (code 878)	1 1 1 1	----	----	----	----	2432 172-3 2432 174-5 2432 176-7 2432 178-9
	L1-P (code 891) (code 893) (code 895) (code 898)	1 1 1 1	----	----	----	----	*2428 638-9 2432 160-1 *2428 640 2432 162-3 *2428 642-3 2432 164-5 *2428 644-5 2432 166-7
	D1-L, D2-L (2 D.) (code 501) (code 503) (code 505) (code 508) (code 694)	1 1 1 1 1	2297 946-7 2297 948-9 2297 950-1 2297 952-3 2428 856-7				
	D1-M, D2-M (2 D.) (code 521) (code 523) (code 525) (code 526) (code 528)	1 1 1 1 1	2297 980-1 2297 982-3 2297 984-5 2297 986-7 2297 988-9	----	----	2428 610-1 2428 612-3 2428 614-5 2428 616-7 2428 618-9	
	D1, D2 (4 D.) (codes 501, 521, 541, 611, 621, 641) (codes 503, 523, 543, 613, 623, 643) (codes 505, 525, 545, 645)	1 1 1	2431 910-1 2431 912-3 2431 914-5	*2431 910-1 *2431 912-3 *2431 914-5	----	2428 610-1 2428 612-3 2428 614-5	

★ Indicates use as required.  
 ☐ Indicates parts not listed in any previous parts book.  
 Right and left part numbers are on same line,  
 first number is right, second number is left.  
 \* Indicates change or addition.

Printed in U.S.A.  
 Prices and specifications subject to change without notice.  
 Jan. 3, 1964 Supersedes Jan. 25, 1963.

## 1963 PASSENGER CAR PARTS CATALOG

INTERIOR TRIM

CODE	REMARKS	PER CAR	SED.	SP. 4 D.	SUB.	SP. CL. CP.	CV. CP.
23-101-3	PANEL, Rear Quarter Trim-Cont'd D1, D2 (4 D.) (codes 526, 546, 646) (codes 508, 528, 548, 648) (code 694)	1 1 1	2431 916-7 2431 918-9 2431 920-1	*2431 916-7 *2431 918-9	---- ----	2428 616-7 2428 618-9	
	D1-H, D2-H (codes 641, 651) (code 643) (code 645) (code 646) (code 648)	1 1 1 1 1	---- ---- ---- ---- ----	---- ---- ---- ---- ----	---- ---- ---- ---- ----	2428 752-3 2428 754-5 2428 756-7 2428 758-9 2428 760-1	
	D2-P (use w/o courtesy lamp) (code 651) (code 653) (code 655) (code 656) (code 658)	1 1 1 1 1	---- ---- ---- ---- ----	---- ---- ---- ---- ----	---- ---- ---- ---- ----	*2428 786-7 2428 788-9 2428 790-1 2428 792-3 2428 794-5	*2428 801-2 2428 803-4 2428 805-6 2428 807-8 2428 809-10
	D2-H (use w/o courtesy lamp) (code 641) (code 643) (code 645) (code 646) (code 648) (attaching screw and washer)(2 D.) ★	1 1 1 1 1	---- ---- ---- ---- ---- 6023 381	---- ---- ---- ---- ---- ----	---- ---- ---- ---- ---- ----	---- ---- ---- ---- ---- 6023 381	*2432 112-3 2432 114-5 2432 116-7 2432 118-9 2432 120-1 6023 381
	D2-H (use w/courtesy lamp) (code 641) (code 643) (code 645) (code 646) (code 648)	1 1 1 1 1	---- ---- ---- ---- ----	---- ---- ---- ---- ----	---- ---- ---- ---- ----	---- ---- ---- ---- ----	E2432 338-9 E2432 340-1 E2432 342-3 E2432 344-5 E2432 346-7
	D2-P (use w/courtesy lamp) (code 651) (code 653) (code 655) (code 656) (code 658)	1 1 1 1 1	---- ---- ---- ---- ----	---- ---- ---- ---- ----	---- ---- ---- ---- ----	---- ---- ---- ---- ----	*2432 354-5 2432 356-7 2432 358-9 2432 360-1 2432 362-3
	A3-E (code 561) (code 563) (code 565) (code 568) A3-L (code 571) (code 572) (code 573) (code 575) (code 578) (code 584)	1 1 1 1 1 1 1 1 1 1	2137 962-3 2137 964-5 *2137 632-3 2137 968-9 2137 626-7 2137 628-9 2137 630-1 2137 632-3 2137 634-5 2137 694-5	---- ---- ---- ---- ---- ---- ---- ---- ---- ----	---- ---- ---- ---- ---- ---- ---- ---- ---- ----	2181 154-5 2181 158-9 2181 162-3 2181 166-7 2181 170-1	
	(code 671) (code 672) (code 673) (code 675) (code 678) (code 684)	1 1 1 1 1 1	---- ---- ---- ---- ---- 2137 768-9	2137 716-7 2137 718-9 2137 720-1 2137 722-3 2137 724-5	---- ---- ---- ---- ----	---- ---- ---- ---- ----	2181 176-7 2181 178-9 2181 180-1 2181 182-3 2181 184-5
23-101-14	COVER, Upper Quarter Front Trim (paint as required) D1, D2	1	----	----	2297 504-5		

★ Indicates use as required.

E Indicates parts not listed in any previous parts book.

Jan. 3, 1964 Supersedes Jan. 25, 1963.

Printed in U.S.A.  
Prices and specifications subject to change without notice.  
Right and left part numbers are on same line,  
first number is right, second number is left.

\* Indicates change or addition.

CODE	REMARKS	PER CAR	SED.	SP. 4 D.	SUB.	SP. CL. CP.	CV. CP.
23-101-33	BRACKET, Quarter Trim Panel Support D2	2	----	----	----	----	E2490 484
23-102-3	PANEL, Shelf Trim L1						
	(blue)	1	2428 998	----	----	2428 998	
	(tan)	1	2428 999	----	----	2428 999	
	(red)	1	2429 000	----	----	2429 000	
	(turquoise)	1	2429 001	----	----	2429 001	
	D1, D2						
	(blue)	1	2429 060	2429 060	----	2429 060	
	(tan)	1	2429 061	2429 061	----	2429 061	
	(red)	1	2429 062	2429 062	----	2429 062	
	(turquoise)	1	2429 064	2429 064	----	2429 064	
	(black)	1	2429 063	2429 063	----	2429 063	
	(fastener)	★	6000 903	6000 903	----	6000 903	
	A3 (w/extension)						
	(blue)	1	2181 447	2181 447	----	2181 453	
	(green)	1	2181 448	2181 448	----	2181 454	
	(tan)	1	2181 449	2181 449	----	2181 455	
	(red)	1	2181 450	2181 450	----	2181 456	
	(turquoise)	1	2181 451	2181 451	----	2181 457	
	(black)	1	2181 452				
23-103-3	PANEL, Visor Trim L1-L, L1-H						
	(codes 801, 831, 851, 871)(blue)	2	2413 805	----	2413 805		
	(codes 803, 805, 833, 835, 853, 855, 873, 875, 893, 895)						
	(alabaster)	2	2297 598	----	2297 598	2413 442	
	(codes 808, 838, 858, 878)						
	(turquoise)	2	2413 807	----	2413 807		
	L1-H, L1-P						
	(codes 871, 891)	2	----	----	----	2413 441	2432 222
	(codes 873, 893)	2	----	----	----	2413 442	2432 223
	(codes 875, 895)	2	----	----	----	*2413 442	2432 224
	(codes 878, 898)	2	----	----	----	*2413 443	2432 225
	D1, D2						
	(codes 501, 521, 541, 611, 621, 641) (blue)	2	2413 812	2413 812	----	2413 812	
	(codes 503, 505, 523, 525, 526, 543, 545, 546, 613, 623, 643, 645, 646) (alabaster)	2	2413 421	2413 421	----	2413 421	
	(codes 508, 528, 548, 648) (turquoise)	2	2413 814	2413 814	----	2413 814	
	(codes 601, 603, 605, 608) (white)	2	----	2273 286	2273 286	2273 286	
	(codes 621, 623, 625, 626, 628, 641, 643, 645, 646, 648, 651, 653, 655, 656, 658)(white)	2	----	2297 803	2297 803	2297 803	
	(codes 684, 699) (gray)	2	E1118 TA2				
	(codes 808, 838, 858, 878) (turquoise)	2	2413 807	----	2413 807		
	D1, D2						
	(code 523)	2	----	----	----	----	2413 425
	(code 641)	2	----	----	----	----	2413 424
	(code 645)	2	----	----	----	----	2413 426
	(codes 646, 651, 653, 655, 656, 658)	2	----	----	----	----	2413 427
	(code 648)	2	----	----	----	----	2413 428

★ Indicates use as required.

☐ Indicates parts not listed in any previous parts book.  
Right and left part numbers are on same line,  
first number is right, second number is left.

\* Indicates change or addition.

Printed in U.S.A.

Prices and specifications subject to change without notice.

Jan. 3, 1964 Supersedes Dec. 14, 1962.

## 1963 PASSENGER CAR PARTS CATALOG

INTERIOR TRIM

CODE	REMARKS	PER CAR	SED.	SP. 4 D.	SUB.	SP. CL. CP.	CV. CP.
23-103-3	PANEL, Visor Trim - Cont'd A3-L						
	(code 671) (blue)	2	----	----	----	----	*2181 424
	(codes 671, 678) (white)	2	----	----	*2181 490	----	
	(code 672) (green)	2	----	----	----	----	*2181 425
	(code 673) (tan)	2	----	----	----	----	*2181 426
	(code 675) (red)	2	----	----	----	----	*2181 427
	(code 678) (turquoise)	2	----	----	----	----	*2181 428
	A3-E						
	(codes 561, 571, 671) (blue)	2	*2181 419				
	(short)	2	2181 431				
	(codes 571, 578, 678) (white)	2	----	*2181 429	*2181 429	*2181 429	
	(codes 572, 573, 575, 672, 673, 675) (white)	2	----	2181 430	2181 430	2181 430	
	(code 572) (green)	2	2181 420				
	(code 572) (green)(short)	2	2181 432				
	(codes 565, 573, 575)(alabaster)	2	*2181 421				
	(short)	2	2181 433				
	(code 578) (turquoise)	2	*2181 422				
	(short)	2	2181 434				
	(codes 584, 684) (gray)	2	2181 423				
	(short)	2	2181 435				
23-103-10	ARM and BRACKET, Visor L1-L, L1-H	1	2292 580	----	2292 580	2292 580	
	L1-P (chrome)	1	----	----	----	2292 580-1	
	ARM, Visor (anti-rattler and lock catch)	1	----	----	----	----	2424 470-1
	D1, D2 (chrome)	1	2292 894-5	2292 894-5	2292 894-5	2292 894-5	2162 686-7
	A3 (painted) Rt.	1	2292 380	2292 380			
	Lt.	1	*2082 677	*2082 677			
	A3 (chrome)	1	2292 108-9	2292 108-9	2292 108-9	----	1954 926-7
23-103-18	WASHER, Visor Arm Tension L1, D1, D2, A3	2	6000 106	6000 106	6000 106	6000 106	6000 106
23-103-34	HOOK, Windshield Visor Support A3	1	1964 262	1964 262	1964 262	1964 262	1964 332
23-103-37	SPACER, Windshield Visor Support Hook A3	2	2165 039	2165 039	2165 039	2165 039	
23-103-48	SUPPORT, Visor Inner D1, D2	2	2162 628	2162 628	2162 628	2162 628	2162 628
	A3	2	*2193 096	2193 096	*2193 096	2193 096	2193 096
23-108-4	CUSHION, Front Seat L1-L (2 D.)						
	(code 801)	1	2296 704				
	(w/airfoam pad)	1	2296 708				
	(w/heavy duty spring)	1	2296 712				
	(w/pad and spring)	1	2296 716				
	(code 803)	1	2296 705				
	(w/airfoam pad)	1	2296 709				
	(w/heavy duty spring)	1	2296 713				
	(w/pad and spring)	1	2296 717				
	(code 805)	1	2296 706				
	(w/airfoam pad)	1	2296 710				
	(w/heavy duty spring)	1	2296 714				
	(w/pad and spring)	1	2296 718				

★ Indicates use as required.

⊠ Indicates parts not listed in any previous parts book.

Jan. 3, 1964 Supersedes Dec. 14, 1962.

Printed in U.S.A.

Prices and specifications subject to change without notice.

Right and left part numbers are on same line,

first number is right, second number is left.

\* Indicates change or addition

CODE	REMARKS	PER CAR	SED.	SP. 4 D.	SUB.	SP. CL. CP.	CV. CP.
23-108-4	CUSHION, Front Seat - Cont'd						
	L1-L (2 D.)						
	(code 808)	1	2296 707				
	(w/airfoam pad)	1	2296 711				
	(w/heavy duty spring)	1	2296 715				
	(w/pad and spring)	1	2296 719				
	L1-L (4 D.)						
	(codes 801, 851)	1	2296 796	----	2296 844		
	(w/airfoam pad)	1	2296 800	----	2296 852		
	(w/heavy duty spring)	1	2296 804	----	2296 848		
	(w/pad and spring)	1	2296 808	----	2296 856		
	(codes 803, 853)	1	2296 797	----	2296 845		
	(w/airfoam pad)	1	2296 801	----	2296 853		
	(w/heavy duty spring)	1	2296 805	----	2296 849		
	(w/pad and spring)	1	2296 809	----	2296 857		
	(codes 805, 855)	1	2296 798	----	2296 846		
	(w/airfoam pad)	1	2296 806	----	2296 854		
	(w/heavy duty spring)	1	2296 802	----	2296 850		
	(w/pad and spring)	1	2296 810	----	2296 858		
	(code 808)	1	2296 799	----	2296 847		
	(w/airfoam pad)	1	2296 803	----	2296 855		
	(w/heavy duty spring)	1	2296 807	----	2296 851		
	(w/pad and spring)	1	2296 811	----	2296 859		
	(code 871)	1	2415 310	----	2415 310		
	(w/airfoam pad)	1	2415 314	----	2415 314		
	(code 873)	1	2415 311	----	2415 311		
	(w/airfoam pad)	1	2415 315	----	2415 315		
	(code 875)	1	2415 312	----	2415 312		
	(w/airfoam pad)	1	2415 316	----	2415 316		
	(code 878)	1	2415 313	----	2415 313		
	(w/airfoam pad)	1	2415 317	----	2415 317		
	(code 891)	1	----	----	----	2415 718-9	2415 718-9
	(code 893)	1	----	----	----	2415 720-1	2415 720-1
	(code 894)	1	2411 209	----	----		
	(code 895)	1	----	----	----	2415 722-3	2415 722-3
	(code 898)	1	----	----	----	2415 724-5	2415 724-5

NOTE: On Items Marked Light or Dark Include Sample With Order.

LI-H (2 D.)							
(codes 831, 871) (light)	1	*2292 676	----	----	----		*2433 009
(w/airfoam pad)	1	2296 680	----	----	----		2433 013
(code 831) (dark)	1	E2433 366					
(w/airfoam pad)	1	E2433 368					
(codes 833, 873)	1	2296 677	----	----	----		2433 010
(w/airfoam pad)	1	2296 681	----	----	----		2433 014
(codes 835, 875)	1	2296 678	----	----	----		2433 011
(w/airfoam pad)	1	2296 682	----	----	----		2433 015
(codes 838, 878) (light)	1	*2296 679	----	----	----		*2433 012
(w/airfoam pad)	1	2296 683	----	----	----		2433 016
(code 838) (dark)	1	E2433 367					
(w/airfoam pad)	1	E2433 369					
LI-H (4 D.)							
(code 831) (light)	1	*2296 948					
(w/airfoam pad)	1	2296 952					
(code 831) (dark)	1	E2433 404					
(w/airfoam pad)	1	E2433 406					
(code 833)	1	2296 949					
(w/airfoam pad)	1	2296 953					
(code 835)	1	2296 950					
(w/airfoam pad)	1	2296 954					
(code 838) (light)	1	*2296 951					
(w/airfoam pad)	1	2296 955					

★ Indicates use as required.

☐ Indicates parts not listed in any previous parts book.

Right and left part numbers are on same line, first number is right, second number is left.

\* Indicates change or addition.

Printed in U.S.A. Prices and specifications subject to change without notice.

Jan. 3, 1964 Supersedes Dec. 14, 1962.

## 1963 PASSENGER CAR PARTS CATALOG

INTERIOR TRIM

CODE	REMARKS	PER CAR	SED.	SP. 4 D.	SUB.	SP. CL. CP.	CV. CP.
23-108-4	CUSHION, Front Seat-Cont'd						
	L1-H (4 D.)						
	(code 838) (dark)	1	E2433 405				
	(w/airfoam pad)	1	E2433 407				
	D1, D2 (2 D.)						
	(code 501)	1	E2433 106				
	(w/airfoam pad)	1	E2433 110				
	(w/heavy duty spring and airfoam pad)	1	*2433 114				
	D1, D2 (4 D.)						
	(code 501)	1	2415 262				
	(w/airfoam pad)	1	2415 266				
	(w/heavy duty spring and airfoam pad)	1	2415 270				
	D1, D2 (2 D.)						
	(code 503)	1	E2433 107				
	(w/airfoam pad)	1	E2433 111				
	(w/heavy duty spring and airfoam pad)	1	E2433 115				
	D1, D2 (4 D.)						
	(code 503)	1	2415 263				
	(w/airfoam pad)	1	2415 267				
	(w/heavy duty spring and airfoam pad)	1	2415 271				
	D1, D2 (2 D.)						
	(code 505)	1	E2433 108				
	(w/airfoam pad)	1	E2433 112				
	(w/heavy duty spring and airfoam pad)	1	E2433 116				
	D1, D2 (4 D.)						
	(code 505)	1	2415 264				
	(w/airfoam pad)	1	2415 268				
	(w/heavy duty spring and airfoam pad)	1	2415 272				
	D1, D2 (2 D.)						
	(code 508)	1	E2433 109				
	(w/airfoam pad)	1	E2433 113				
	(w/heavy duty spring and airfoam pad)	1	E2433 117				
	D1, D2 (4 D.)						
	(code 508)	1	2415 265				
	(w/airfoam pad)	1	2415 269				
	(w/heavy duty spring and airfoam pad)	1	2415 273				
	D1, D2 (2 D.)						
	(code 521)	1	E2433 185	----	----	E2433 185	
	(w/heavy duty spring)	1	E2433 190	----	----	E2433 190	
	(code 523)	1	E2433 186	----	----	E2433 186	
	(w/heavy duty spring)	1	E2433 191	----	----	E2433 191	
	(code 525)	1	E2433 187	----	----	E2433 187	
	(w/heavy duty spring)	1	E2433 192	----	----	E2433 192	
	(code 526)	1	E2433 188	----	----	E2433 188	
	(w/heavy duty spring)	1	E2433 193	----	----	E2433 193	
	(code 528)	1	E2433 189	----	----	E2433 189	
	(w/heavy duty spring)	1	E2433 194	----	----	E2433 194	
	D1, D2 (4 D.)						
	(code 521)	1	E2433 235				
	(w/heavy duty spring)	1	E2433 240				
	(code 523)	1	E2433 236				
	(w/heavy duty spring)	1	E2433 241				

★ Indicates use as required.

E Indicates parts not listed in any previous parts book.

Jan. 3, 1964 Supersedes Dec. 14, 1962.

Page IT-138

Printed in U.S.A.

Prices and specifications subject to change without notice.

Right and left part numbers are on same line, first number is right, second number is left.

\* Indicates change or addition.

CODE	REMARKS	PER CAR	SED.	SP. 4 D.	SUB.	SP. CL. CP.	CV. CP.
23-108-4	CUSHION, Front Seat-Cont'd						
	D1, D2 (4 D.)						
	(code 525)	1	E2433 237				
	(w/heavy duty spring)	1	E2433 242				
	(code 526)	1	E2433 238				
	(w/heavy duty spring)	1	E2433 243				
	(code 528)	1	E2433 239				
	(w/heavy duty spring)	1	E2433 244				
	(code 541)	1	2431 320				
	(w/elec. seat 6 way)	1	2431 325				
	(code 543)	1	2431 321				
	(w/elect. seat 6 way)	1	2431 326				
	(code 545)	1	2431 322				
	(w/elect. seat 6 way)	1	2431 327				
	(code 546)	1	2431 323				
	(w/elect. seat 6 way)	1	2431 328				
	(code 548)	1	2431 324				
	(w/elect. seat 6 way)	1	2431 329				
A3-E							
	(code 561)	1	2137 828	----		2137 828	
	(w/elect. seat)	1	2137 873	----		2137 873	
	(w/airfoam pad)	1	2137 885	----		2137 885	
	(w/elect. seat and air-foam pad)	1	2137 893	----		2137 893	
	(police and ambulance)	1	2137 938	----		2137 938	
	(code 563)	1	2137 829	----		2137 829	
	(w/elect. seat)	1	2137 874	----		2137 874	
	(w/airfoam pad)	1	2137 886	----		2137 886	
	(w/elect. seat and air-foam pad)	1	2137 894	----		2137 894	
	(police and ambulance)	1	2137 939	----		2137 939	
	(code 565)	1	2137 830	----		2137 830	
	(w/elect. seat)	1	2137 875	----		2137 875	
	(w/airfoam pad)	1	2137 887	----		2137 887	
	(w/elect. seat and air-foam pad)	1	2137 895	----		2137 895	
	(police and ambulance)	1	2137 940	----		2137 940	
	(code 568)	1	2137 831	----		2137 831	
	(w/elect. seat)	1	2137 876	----		2137 876	
	(w/airfoam pad)	1	2137 888	----		2137 888	
	(code 568)						
	(w/elect. seat and air-foam pad)	1	2137 896	----		2137 896	
	(police and ambulance)	1	2137 941	----		2137 941	
	(code 584)	1	2133 065				
	(code 684)	1	2133 549				
	(code 694)	1	E2429 895				
A3-L							
	(code 571)	1	2136 969	----	----	2137 164	
	(w/elec. seat 6 way)	1	2137 041	----	----	2137 229	
	(w/airfoam pad)	1	2137 239	----	----	2137 542	
	(w/elect. seat 6 way and airfoam pad)	1	2137 244	----	----	2137 552	
	(police)	1	2137 582				
	(code 572)	1	2136 970	----	----	2137 165	
	(w/elect. seat 6 way)	1	2137 042	----	----	2137 230	
	(w/airfoam pad)	1	*2137 240	----	----	2137 543	
	(w/elect. seat 6 way and airfoam pad)	1	2137 245	----	----	2137 553	
	(police)	1	2137 583				

★ Indicates use as required.

☐ Indicates parts not listed in any previous parts book.

Right and left part numbers are on same line, first number is right, second number is left.

\* Indicates change or addition.

Printed in U.S.A.  
Prices and specifications subject to change without notice.  
Jan. 3, 1964 Supersedes Dec. 14, 1962.

# 1963 PASSENGER CAR PARTS CATALOG

INTERIOR TRIM

CODE	REMARKS	PER CAR	SED.	SP. 4 D.	SUB.	SP. CL. CP.	CV. CP.
23-108-4	CUSHION, Front Seat-Cont'd A3-L						
	(code 573)	1	2136 971	----	----	2137 166	
	(w/elect. seat 6 way)	1	2137 043	----	----	2137 231	
	(w/airfoam pad)	1	2137 241	----	----	2137 544	
	(w/elect. seat 6 way and airfoam pad)	1	2137 246	----	----	2137 554	
	(police)	1	2137 584	----	----		
	(code 575)	1	2136 972	----	----	2137 167	
	(w/elect. seat 6 way)	1	2137 044	----	----	2137 232	
	(w/airfoam pad)	1	2137 242	----	----	2137 545	
	(w/elect. seat 6 way and airfoam pad)	1	2137 247	----	----	2137 555	
	(police)	1	2137 585	----	----		
	(code 578)	1	2136 973	----	----	2137 168	
	(w/elect. 6 way seat)	1	2137 045	----	----	2137 233	
	(w/airfoam pad)	1	2137 243	----	----	2137 546	
	(w/elect. seat 6 way and airfoam pad)	1	2137 248	----	----	2137 556	
	(police)	1	2137 586	----	----		
	D1, D2 (2 D.)						
	(code 594)	1	2429 843				
	(4 D.)	1	2429 830				
	D1, D2						
	(code 601)	1	----	----	2415 378		
	(w/airfoam pad)	1	----	----	2415 382		
	(w/heavy duty spring)	1	----	----	2415 386		
	(w/heavy duty spring and airfoam pad)	1	----	----	2415 390		
	(code 603)	1	----	----	2415 379		
	(w/airfoam pad)	1	----	----	2415 383		
	(w/heavy duty spring)	1	----	----	2415 387		
	(w/heavy duty spring and airfoam pad)	1	----	----	2415 391		
	(code 605)	1	----	----	2415 380		
	(w/airfoam pad)	1	----	----	2415 384		
	(w/heavy duty spring)	1	----	----	2415 388		
	(w/heavy duty spring and airfoam pad)	1	----	----	2415 392		
	(code 608)	1	----	----	2415 381		
	(w/airfoam pad)	1	----	----	2415 385		
	(w/heavy duty spring)	1	----	----	2415 389		
	(w/heavy duty spring and airfoam pad)	1	----	----	2415 393		
	D1, D2 (4 D.)						
	(codes 611, 621)	1	E2433 260				
	(w/heavy duty spring)	1	E2433 265	----	E2433 265		
	(codes 613, 623)	1	E2433 261				
	(w/heavy duty spring)	1	E2433 266	----	E2433 266		
	(code 625)	1	----	----	E2433 262		
	(w/heavy duty spring)	1	----	----	E2433 267		
	(code 626)	1	----	----	E2433 263		
	(w/heavy duty spring)	1	----	----	E2433 268		
	(code 628)	1	----	----	E2433 264		
	(w/heavy duty spring)	1	----	----	E2433 269		
	D1, D2 (2 D.)						
	(code 641)	1	----	----	----	2431 610	2431 610
	(w/elect. seat 6 way)	1	----	----	----	2431 615	2431 615

★ Indicates use as required.

⊠ Indicates parts not listed in any previous parts book.

Jan. 3, 1964 Supersedes Dec. 14, 1962.

Printed in U.S.A.  
Prices and specifications subject to change without notice.  
Right and left part numbers are on same line,  
first number is right, second number is left.

\* Indicates change or addition.



CODE	REMARKS	PER CAR	SED.	SP. 4 D.	SUB.	SP. CL. CP.	CV. CP.
23-108-4	CUSHION, Front Seat-Cont'd						
	D1, D2 (2 D.)						
	(code 643)	1	----	----	----	2431 611	2431 611
	(w/elect. seat 6 way)	1	----	----	----	2431 616	2431 616
	(code 645)	1	----	----	----	2431 612	2431 612
	(w/elect. seat 6 way)	1	----	----	----	2431 617	2431 617
	(code 646)	1	----	----	----	2431 613	2431 613
	(w/elect. seat 6 way)	1	----	----	----	2431 618	2431 618
	(code 648)	1	----	----	----	2431 614	2431 614
	(w/elect. seat 6 way)	1	----	----	----	2431 619	2431 619
	(code 651)	2	----	----	----	*2431 770	*2431 770
	(code 653)	2	----	----	----	*2431 771	*2431 771
	(code 655)	2	----	----	----	*2431 772	*2431 772
	(code 656)	2	----	----	----	*2431 773	*2431 773
	(code 658)	2	----	----	----	*2431 774	*2431 774
	D1, D2 (4 D.)						
	(code 641)	1	2431 565	2431 565			
	(w/elect. seat 6 way)	1	2431 570	2431 570			
	(code 643)	1	2431 566	2431 566			
	(w/elect. seat 6 way)	1	2431 571	2431 571			
	(code 645)	1	2431 567	2431 567			
	(w/elect. seat 6 way)	1	2431 572	2431 572			
	(code 646)	1	2431 568	2431 568			
	(w/elect. seat 6 way)	1	2431 573	2431 573			
	(code 648)	1	2431 569	2431 569			
	(w/elect. seat 6 way)	1	2431 574	2431 574			
	A3-L						
	(code 671)	1	----	2137 305	2137 305	----	2137 422
	(w/airfoam pad)	1	----	2137 472	2137 472	----	2137 477
	(police and ambulance)	1	----	----	2137 567	----	
	(code 672)	1	----	2137 306	2137 306	----	2137 423
	(w/airfoam pad)	1	----	----	----	----	2137 478
	(w/elect. seat 6 way)	1	----	2137 473	2137 473	----	
	(police and ambulance)	1	----	----	2137 568	----	
	(code 673)	1	----	2137 307	2137 307	----	2137 424
	(w/airfoam pad)	1	----	----	----	----	2137 479
	(w/elect. seat 6 way)	1	----	2137 474	2137 474	----	
	(police and ambulance)	1	----	----	2137 569	----	
	(code 675)	1	----	2137 308	2137 308	----	2137 425
	(w/airfoam pad)	1	----	----	----	----	2137 480
	(w/elect. seat 6 way)	1	----	2137 475	2137 475	----	
	(police and ambulance)	1	----	----	2137 570	----	
	(code 678)	1	----	2137 309	2137 309	----	2137 426
	(w/airfoam pad)	1	----	----	----	----	2137 481
	(w/elect. seat 6 way)	1	----	2137 476	2137 476	----	
	(police and ambulance)	1	----	----	2137 571	----	
23-108-5	COVER, Front Seat Cushion						
	L1-L (2 D.)						
	(code 801)	1	2296 700				
	(code 803)	1	2296 701				
	(code 805)	1	2296 702				
	(code 808)	1	2296 703				
	L1-H (2 D.)						
	(code 831)	1	*2433 360				
	(code 833)	1	2296 673				
	(code 835)	1	2296 674				
	(code 838)	1	⊠2433 361				
	(code 871)	1	----	----	----	----	2433 005
	(code 873)	1	----	----	----	----	2433 006
	(code 875)	1	----	----	----	----	2433 007
	(code 878)	1	----	----	----	----	2433 008

★ Indicates use as required.  
 ⊠ Indicates parts not listed in any previous parts book.  
 Right and left part numbers are on same line,  
 first number is right, second number is left.  
 \* Indicates change or addition.

Printed in U.S.A.  
 Prices and specifications subject to change without notice.  
 Jan. 3, 1964 Supersedes Dec. 14, 1962.

# 1963 PASSENGER CAR PARTS CATALOG

INTERIOR TRIM

CODE	REMARKS	PER CAR	SED.	SP. 4 D.	SUB.	SP. CL. CP.	CV. CP.
23-108-5	COVER, Front Seat Cushion - Cont'd						
	L1-L (4 D.)						
	(codes 801, 851)	1	2296 792	----	2296 840		
	(codes 803, 853)	1	2296 793	----	2296 841		
	(codes 805, 855)	1	2296 794	----	2296 842		
	(codes 808, 858)	1	2296 795	----	2296 843		
	(code 871)	1	2415 298				
	(code 873)	1	2415 299				
	(code 875)	1	2415 300				
	(code 878)	1	2415 301				
	(code 894)	1	2274 324				
	L1-H (4 D.)						
	(code 831)	1	E2433 402				
	(code 833)	1	2296 937				
	(code 835)	1	2296 938				
	(code 838)	1	E2433 403				
	(code 871)	1	2415 298	----	2415 298		
	(code 873)	1	2415 299	----	2415 299		
	(code 875)	1	2415 300	----	2415 300		
	(code 878)	1	2415 301	----	2415 301		
	L1-P						
	(code 891)	2	----	----	----	2415 714	2415 714
	(code 893)	2	----	----	----	2415 715	2415 715
	(code 895)	2	----	----	----	2415 716	2415 716
	(code 898)	2	----	----	----	2415 717	2415 717
	D1-L, D2-L (2 D.)						
	(code 501)	1	2415 159				
	(code 503)	1	2415 160				
	(code 505)	1	2415 161				
	(code 508)	1	2415 162				
	(code 594)	1	2429 842				
	D1-L, D2-L (4 D.)						
	(codes 501, 601)	1	2415 258	----	2415 370		
	(codes 503, 603)	1	2415 259	----	2415 371		
	(codes 505, 605)	1	2415 260	----	2415 372		
	(codes 508, 608)	1	2415 261	----	2415 373		
	(code 594)	1	2429 829				
	(code 611)	1	E2433 255				
	(code 613)	1	E2433 256				
	D1-M, D2-M (2 D.)						
	(code 521)	1	E2433 180	----	----	E2433 180	E2433 180
	(code 523)	1	E2433 181	----	----	E2433 181	E2433 181
	(code 525)	1	E2433 182	----	----	E2433 182	E2433 182
	(code 526)	1	E2433 183	----	----	E2433 183	E2433 183
	(code 528)	1	E2433 184	----	----	E2433 184	E2433 184
	D1-M, D2-M (4 D.)						
	(code 521)	1	E2433 230	E2433 230			
	(code 523)	1	E2433 231	E2433 231			
	(code 525)	1	E2433 232	E2433 232			
	(code 526)	1	E2433 233	E2433 233			
	(code 528)	1	E2433 234	E2433 234			
	(code 621)	1	E2433 256	----	E2433 256		
	(code 623)	1	E2433 256	----	E2433 256		
	(code 625)	1	----	----	E2433 257		
	(code 626)	1	----	----	E2433 258		
	(code 628)	1	----	----	E2433 259		
	D1-H, D2-H (4 D.)						
	(code 541)	1	2431 305				
	(code 543)	1	2431 306				
	(code 545)	1	2431 307				

★ Indicates use as required.

⊠ Indicates parts not listed in any previous parts book.  
 Jan. 3, 1964 Supersedes Dec. 14, 1962.

Printed in U.S.A.

Prices and specifications subject to change without notice.  
 Right and left part numbers are on same line,  
 first number is right, second number is left.

\* Indicates change or addition.

CODE	REMARKS	PER CAR	SED.	SP. 4 D.	SUB.	SP. CL. CP.	CV. CP.
23-108-5	COVER, Front Seat - Cont'd						
	D1-H, D2-H (4 D.)						
	(code 546)	1	2431 308				
	(code 548)	1	2431 309				
	D2-P						
	(code 651)	2	-----	-----	-----	2431 765	2431 765
	(code 653)	2	-----	-----	-----	2431 766	2431 766
	(code 655)	2	-----	-----	-----	2431 767	2431 767
	(code 656)	2	-----	-----	-----	2431 768	2431 768
	(code 658)	2	-----	-----	-----	2431 769	2431 769
	(code 694)	1	E2429 895				
	D1-H, D2-H						
	(code 641)	1	2431 560	2431 560	-----	2431 560	2431 560
	(code 643)	1	2431 561	2431 561	-----	2431 561	2431 561
	(code 645)	1	2431 562	2431 562	-----	2431 562	2431 562
	(code 646)	1	2431 563	2431 563	-----	2431 563	2431 563
	(code 648)	1	2431 564	2431 564	-----	2431 564	2431 564
	A3-E						
	(code 561)	1	E2137 832	-----	E2137 832		
	(code 563)	1	E2137 833	-----	E2137 833		
	(code 565)	1	E2137 834	-----	E2137 834		
	(code 568)	1	E2137 835	-----	E2137 835		
	(code 584)	1	*2133 066				
	(code 684)	1	*2133 550				
	A3-L						
	(code 571)	1	2136 974	-----	-----	2137 169	
	(code 572)	1	2136 975	-----	-----	2137 170	
	(code 573)	1	2136 976	-----	-----	2137 171	
	(code 575)	1	2136 977	-----	-----	2137 172	
	(code 578)	1	2136 978	-----	-----	2137 173	
	(code 671)	1	-----	2137 310	2137 310	-----	2137 427
	(code 672)	1	-----	2137 311	2137 311	-----	2137 428
	(code 673)	1	-----	2137 312	2137 312	-----	2137 429
	(code 675)	1	-----	2137 313	2137 313	-----	2137 430
	(code 678)	1	-----	2137 314	2137 314	-----	2137 431
23-108-12	BACK, Front Seat						
	L1 (2 D.)						
	(code 801)	1	*2296 728-9				
	(w/airfoam pad and heavy duty spring)	1	2296 736-7				
	(code 803)	1	2296 730-1				
	(w/airfoam pad and heavy duty spring)	1	2296 738-9				
	(code 805)	1	2296 732-3				
	(w/airfoam pad and heavy duty spring)	1	2296 740-1				
	(code 808)	1	2296 734-5				
	(w/airfoam pad and heavy duty spring)	1	2296 742-3				
	L1 (2 D.)						
	(code 831)	1	2296 692-3				
	(code 833)	1	2296 694-5				
	(code 835)	1	2296 696-7				
	(code 838)	1	2296 698-9				
	L1 (4 D.)						
	(codes 801, 851)	1	2296 816	-----	2296 864		
	(w/airfoam pad and heavy duty spring)	1	2296 820	-----	2296 868		
	(codes 803, 853)	1	2296 817	-----	2296 865		
	(w/airfoam pad and heavy duty spring)	1	2296 821	-----	2296 869		

★ Indicates use as required.  
 □ Indicates parts not listed in any previous parts book.  
 Right and left part numbers are on same line, first number is right, second number is left.  
 \* Indicates change or addition.

Printed in U.S.A.  
 Prices and specifications subject to change without notice.  
 Jan. 3, 1964 Supersedes Dec. 14, 1962.

## 1963 PASSENGER CAR PARTS CATALOG

INTERIOR TRIM

CODE	REMARKS	PER CAR	SED.	SP. 4 D.	SUB.	SP. CL. CP.	CV. CP.
23-108-12	BACK, Front Seat - Cont'd						
	L1 (4 D.)						
	(codes 805, 855)	1	2296 818	----	2296 866		
	(w/airfoam pad and heavy duty spring)	1	2296 822	----	2296 870		
	(codes 808, 858)	1	2296 819	----	2296 867		
	(w/airfoam pad and heavy duty spring)	1	2296 823	----	2296 871		
	L1-H (4 D.)						
	(code 831)	1	2296 968				
	(code 833)	1	2296 969				
	(code 835)	1	2296 970				
	(code 838)	1	2296 971				
	L1 (4 D.)						
	(code 871)	1	2415 330	----	2415 330	----	2433 026-7
	(code 873)	1	2415 331	----	2415 331	----	2433 028-9
	(code 875)	1	2415 332	----	2415 332	----	2433 030-1
	(code 878)	1	2415 333	----	2415 333	----	2433 032-3
	(code 894)	1	----	----	2414 809		
	D1, D2 (2 D.)						
	(code 501)	1	E2433 118-9				
	(w/heavy duty spring)	1	E2433 126-7				
	(code 503)	1	E2433 120-1				
	(w/heavy duty spring)	1	E2433 128-9				
	(code 505)	1	E2433 122-3				
	(w/heavy duty spring)	1	E2433 130-1				
	(code 508)	1	E2433 124-5				
	(w/heavy duty spring)	1	E2433 132-3				
	(code 521)	1	2431 210-1	----	----	2431 210-1	
	(w/heavy duty spring)	1	2431 220-1	----	----	2431 220-1	
	(code 523)	1	2431 212-3	----	----	2431 212-3	
	(w/heavy duty spring)	1	2431 222-3	----	----	2431 222-3	
	(code 525)	1	2431 214-5	----	----	2431 214-5	
	(w/heavy duty spring)	1	2431 224-5	----	----	2431 224-5	
	(code 526)	1	2431 216-7	----	----	2431 216-7	
	(w/heavy duty spring)	1	2431 226-7	----	----	2431 226-7	
	(code 528)	1	2431 218-9	----	----	2431 218-9	
	(w/heavy duty spring)	1	2431 228-9	----	----	2431 228-9	
	(code 594)	1	2429 848-9				
	(w/ash receiver)(rt. only)	1	2429 850				
	(code 694) (2 D.)	1	E2429 898-9				
	(w/ash receiver) Rt.	1	E2429 900				
	(w/heavy duty spring) Rt.	1	E2429 909				
	(w/air foam pad and heavy duty spring)	1	E2429 901-2				
	D1, D2 (4 D.)						
	(code 501)	1	2415 278				
	(w/heavy duty spring)	1	2415 282				
	(code 503)	1	2415 279				
	(w/heavy duty spring)	1	2415 283				
	(code 505)	1	2415 280				
	(w/heavy duty spring)	1	2415 284				
	(code 508)	1	2415 281				
	(w/heavy duty spring)	1	2415 285				
	(code 521)	1	2431 120				
	(w/heavy duty spring)	1	2431 125				
	(code 523)	1	2431 121				
	(w/heavy duty spring)	1	2431 126				
	(code 525)	1	2431 122				
	(w/heavy duty spring)	1	2431 127				

★ Indicates use as required.

☐ Indicates parts not listed in any previous parts book.

Jan. 3, 1964 Supersedes Dec. 14, 1962.

Printed in U.S.A.

Prices and specifications subject to change without notice.

Right and left part numbers are on same line,

first number is right, second number is left.

\* Indicates change or addition.

CODE	REMARKS	PER CAR	SED.	SP. 4 D.	SUB.	SP. CL. CP.	CV. CP.
23-108-12	BACK, Front Seat - Cont'd						
	D1, D2 (4 D.)						
	(code 526)	1	*2431 123				
	(w/heavy duty spring)	1	2431 128				
	(code 528)	1	2431 124				
	(w/heavy duty spring)	1	2431 129				
	(code 541)	1	2431 350-1				
	(code 543)	1	2431 352-3				
	(code 545)	1	2431 354-5				
	(code 546)	1	2431 356-7				
	(code 548)	1	2431 358-9				
	(code 594)	1	2429 833				
	(code 601)	1	----	----	2415 402		
	(w/heavy duty spring)	1	----	----	2415 406		
	(code 603)	1	----	----	2415 403		
	(w/heavy duty spring)	1	----	----	2415 407		
	(code 605)	1	----	----	2415 404		
	(w/heavy duty spring)	1	----	----	2415 408		
	(code 608)	1	----	----	2415 405		
	(w/heavy duty spring)	1	----	----	2415 409		
	(codes 611, 621)	1	2415 975	----	2415 975		
	(w/heavy duty spring)	1	2415 980	----	2415 980		
	(codes 613, 623)	1	2415 976	----	2415 976		
	(w/heavy duty spring)	1	2415 981	----	2415 981		
	(code 625)	1	----	----	2415 977		
	(w/heavy duty spring)	1	----	----	2415 982		
	(code 626)	1	----	----	2415 978		
	(w/heavy duty spring)	1	----	----	2415 983		
	(code 628)	1	----	----	2415 979		
	(w/heavy duty spring)	1	----	----	2415 984		
	D1, D2 (2 D.)						
	(code 641)	1	----	----	----	2431 620-1	
	(code 643)	1	----	----	----	2431 622-3	
	(code 645)	1	----	----	----	2431 624-5	
	(code 646)	1	----	----	----	2431 626-7	
	(code 648)	1	----	----	----	2431 628-9	
	D1, D2 (4 D.)						
	(code 641)	1	2431 590-1	2431 590-1			
	(code 643)	1	2431 592-3	2431 592-3			
	(code 645)	1	2431 594-5	2431 594-5			
	(code 646)	1	2431 596-7	2431 596-7			
	(code 648)	1	2431 598-9	2431 598-9			
	(code 694)	1	2415 141				
	(w/ash receiver)	1	2415 142				
	(w/airfoam pad and heavy duty spring)	1	2415 143				
	A3-E (4 D.)						
	(code 561)	1	2137 820	----	2137 820		
	(police and ambulance)	1	2137 934	----	2137 934		
	(code 563)	1	2137 821	----	2137 821		
	(police and ambulance)	1	2137 937	----	2137 937		
	(code 565)	1	2137 822	----	2137 822		
	(police and ambulance)	1	2137 938	----	2137 938		
	(code 568)	1	2137 823	----	2137 823		
	(police and ambulance)	1	2137 939	----	2137 939		
	A3-L (2 D.)						
	(code 571)	1	----	----	----	2137 134-5	
	(code 572)	1	----	----	----	2137 136-7	
	(code 573)	1	----	----	----	2137 138-9	
	(code 575)	1	----	----	----	2137 140-1	
	(code 578)	1	----	----	----	2137 142-3	

★ Indicates use as required.  
 □ Indicates parts not listed in any previous parts book.  
 Right and left part numbers are on same line,  
 first number is right, second number is left.  
 \* Indicates change or addition.

## 1963 PASSENGER CAR PARTS CATALOG

INTERIOR TRIM

CODE	REMARKS	PER CAR	SED.	SP. 4 D.	SUB.	SP. CL. CP.	CV. CP.
23-108-12	BACK, Front Seat - Cont'd						
	A3 (4 D.)						
	(code 571)	1	2136 954				
	(code 572)	1	2136 955				
	(code 573)	1	2136 956				
	(code 575)	1	2136 957				
	(code 578)	1	2136 958				
	(code 584)	1	2133 063				
	(code 684)	1	2133 547				
	A3-L						
	(code 671)	1	----	2137 290	2137 290		
	(code 672)	1	----	2137 291	2137 291	----	2137 394-5
	(code 673)	1	----	2137 292	2137 292	----	2137 396-7
	(code 675)	1	----	2137 293	2137 293	----	2137 398-9
	(code 678)	1	----	*2137 294	*2137 294	----	E2137 400-1
23-108-15	SPRING and COVER, Front Seat Back						
	L1-P						
	(code 891)	2	----	----	----	2415 734	2415 734
	(code 893)	2	----	----	----	2415 735	2415 735
	(code 895)	2	----	----	----	2415 736	2415 736
	(code 898)	2	----	----	----	2415 737	2415 737
	D2-P						
	(code 651)	1	----	----	----	2431 785	2431 785
	(code 653)	1	----	----	----	2431 786	2431 786
	(code 655)	1	----	----	----	2431 787	2431 787
	(code 656)	1	----	----	----	2431 788	2431 788
	(code 658)	1	----	----	----	2431 789	2431 789
23-108-16	COVER, Front Seat Back						
	L1 (2 D.)						
	(code 801)	1	2296 720-1				
	(code 803)	1	2296 722-3				
	(code 805)	1	2296 724-5				
	(code 808)	1	2296 726-7				
	(code 831)	1	E2433 370-1				
	(code 833)	1	2296 686-7				
	(code 835)	1	2296 688-9				
	(code 838)	1	*2433 372-3				
	L1 (4 D.)						
	(codes 801, 851)	1	2296 812	----	2296 860		
	(codes 803, 853)	1	2296 813	----	2296 861		
	(codes 805, 855)	1	2296 814	----	2296 862		
	(codes 808, 858)	1	2296 815	----	2296 863		
	(code 831)	1	E2433 408				
	(code 833)	1	2296 957				
	(code 835)	1	2296 958				
	(code 838)	1	E2433 409				
	(code 871)	1	2415 318	----	2415 318	----	2433 017-8
	(code 873)	1	2415 319	----	2415 319	----	2433 019-20
	(code 875)	1	2415 320	----	2415 320	----	2433 021-2
	(code 878)	1	----	----	2415 321	----	2433 023-4
	L1-P						
	(code 891)	2	----	----	----	2415 730	2415 730
	(code 893)	2	----	----	----	2415 731	2415 731
	(code 895)	2	----	----	----	2415 732	2415 732
	(code 898)	2	----	----	----	2415 733	2415 733

★ Indicates use as required.

☐ Indicates parts not listed in any previous parts book.  
Jan. 3, 1964 Supersedes Jan. 25, 1963.

Printed in U.S.A.

Prices and specifications subject to change without notice.

Right and left part numbers are on same line,  
first number is right, second number is left.

\* Indicates change or addition.

CODE	REMARKS	PER CAR	SED.	SP. 4 D.	SUB.	SP. CL. CP.	CV. CP.
23-108-16	COVER, Front Seat Back-Cont'd						
	D1, D2 (2 D.)						
	(code 501)	1	2415 176-7				
	(code 503)	1	2415 178-9				
	(code 505)	1	2415 180-1				
	(code 508)	1	2415 182-3				
	(code 521)	1	2431 180-1	----	----	2431 180-1	2431 180-1
	(code 523)	1	2431 182-3	----	----	2431 182-3	2431 182-3
	(code 525)	1	2431 184-5	----	----	2431 184-5	2431 184-5
	(code 526)	1	2431 186-7	----	----	2431 186-7	2431 186-7
	(code 528)	1	2431 188-9	----	----	2431 188-9	
	D1, D2 (4 D.)						
	(codes 501, 601)	1	2415 274	----	2415 394		
	(codes 503, 603)	1	2415 275	----	2415 395		
	(codes 505, 605)	1	2415 276	----	2415 396		
	(codes 508, 608)	1	2415 277	----	2415 397		
	(code 521)	1	2431 115	2431 115			
	(code 523)	1	2431 116	2431 116			
	(code 525)	1	2431 117	2431 117			
	(code 526)	1	2431 118				
	(code 528)	1	2431 119				
	(code 541)	1	2431 330-1				
	(code 543)	1	2431 332-3				
	(code 545)	1	2431 334-5				
	(code 546)	1	2431 336-7				
	(code 548)	1	2431 338-9				
	D1-L, D2-L						
	(code 594) (2 D.)	1	2429 846-7				
	(4 D.)	1	2429 832				
	(code 694) (2 D.)	1	⊠2293 654-5				
	(4 D.)	1	*2415 140				
	D1-L, D2-M						
	(codes 611, 621)	1	2415 955	----	2415 955		
	(codes 613, 623)	1	2415 956	----	2415 956		
	(code 625)	1	----	----	2415 957		
	(code 626)	1	----	----	2415 958		
	(code 628)	1	----	----	2415 959		
	D1-H, D2-H						
	(code 641)	1	2431 580-1	2431 580-1	----	2431 580-1	2431 580-1
	(code 643)	1	2431 582-3	2431 582-3	----	2431 582-3	2431 582-3
	(code 645)	1	2431 584-5	2431 584-5	----	2431 584-5	2431 584-5
	(code 646)	1	2431 586-7	2431 586-7	----	2431 586-7	2431 586-7
	(code 648)	1	2431 588-9	2431 588-9	----	2431 588-9	2431 588-9
	D2-P						
	(code 651)	2	----	----	----	2431 780	2431 780
	(code 653)	2	----	----	----	2431 781	2431 781
	(code 655)	2	----	----	----	2431 782	2431 782
	(code 656)	2	----	----	----	2431 783	2431 783
	(code 658)	2	----	----	----	2431 784	2431 784
	A3-E						
	(code 561)	1	2137 824	----	2137 824		
	(code 563)	1	2137 825	----	2137 825		
	(code 565)	1	2137 826	----	2137 826		
	(code 568)	1	2137 827	----	2137 827		
	(code 584)	1	2133 064				
	(code 684)	1	2133 548				
	A3-L						
	(code 571)	1	2136 959	----	----	2137 144-5	
	(code 572)	1	2136 960	----	----	2137 146-7	
	(code 573)	1	2136 961	----	----	2137 148-9	
	(code 575)	1	2136 962	----	----	2137 150-1	
	(code 578)	1	2136 963	----	----	2137 152-3	

★ Indicates use as required.  
 ⊠ Indicates parts not listed in any previous parts book.  
 Right and left part numbers are on same line,  
 first number is right, second number is left.  
 \* Indicates change or addition.

Printed in U.S.A.  
 Prices and specifications subject to change without notice.  
 Jan. 3, 1964 Supersedes Dec. 14, 1962.

CODE	REMARKS	PER CAR	SED.	SP. 4 D.	SUB.	SP. CL. CP.	CV. CP.
23-108-16	COVER, Front Seat Back-Cont'd A3-L						
	(code 671)	1	----	2137 295	2137 295	----	2137 402-3
	(code 672)	1	----	2137 296	2137 296	----	2137 404-5
	(code 673)	1	----	2137 297	2137 297	----	2137 406-7
	(code 675)	1	----	2137 298	2137 298	----	2137 408-9
	(code 678)	1	----	2137 299	2137 299	----	2137 410-1
23-108-32	PANEL or COVER, Back of Front Seat Back						
	L1-P						
	(code 891)	2	----	----	----	2415 742	2415 742
	(code 893)	2	----	----	----	2415 743	2415 743
	(code 895)	2	----	----	----	2415 744	2415 744
	(code 898)	2	----	----	----	2415 745	2415 745
	D2-P						
	(code 651)	2	----	----	----	2431 795	2431 795
	(code 653)	2	----	----	----	2431 796	2431 796
	(code 655)	2	----	----	----	2431 797	2431 797
	(code 656)	2	----	----	----	2431 798	2431 798
	(code 658)	2	----	----	----	2431 799	2431 799
23-108-57	NUT, Front Seat Cushion Bumper to Rear Rail						
	D1, D2 (2 D.)	4	2094 869				
23-108-84	COVER, Front Seat Back Outer Hinge Arm						
	L1 (paint as required) (chrome)	1	*4326 7TZ1	----	----	----	*4326 7TZ1
	D1, D2 (chrome)	1	2413 568-9	2413 568-9	2413 568-9	2413 568-9	
	(2 D.) (alabaster) (plastic)	1	*2413 568-9	----	----	*2413 568-9	
	(clip)	★	E6008 221	E6008 221	E6008 221	E6008 221	
23-108-98	SHIELD, Front Seat Side						
	D1-M, D2-M, D1-H, D2-H						
	(cushion) (manual and power) Rt.	1	2419 412	2419 412	----	2419 412	2419 412
	(cushion) (manual) Lt.	1	2419 413	2419 413	----	2419 413	2419 413
	(cushion) (power) Lt.	1	2419 969	2419 969	----	2419 969	2419 969
	L1, D1-H, D2-H, D2-P						
	(back) (diecast)	2	*2440 152-3	*2440 152-3	----	*2440 152-3	*2440 152-3
	(stamping)	4	*2440 219	*2440 219	----	*2440 219	*2440 219
	L1, D2-P						
	(cushion) (diecast)	1	----	----	----	*2292 492-3	*2292 492-3
	(stamping)	2	*2440 340	*2440 340	----	*2440 340	*2440 340
	A3-L						
	(cushion) (manual and power) Rt.	1	2080 732	2080 732	2080 732	2080 732	2080 732
	(cushion) (power) Lt.	1	2080 733	2080 733	2080 733	2080 733	2080 733
	(cushion) (manual) Lt.	1	2080 737	2080 737	2080 737	2080 737	2080 737
23-108-100	CUP WASHER, Front Seat Side						
	D1, D2						
	Shield to Seat Frame						
	D1, D2	2	2419 974	2419 974	2419 974	2419 974	2419 974
23-108-142	BRACKET, Front Seat Cushion Side Shield Support						
	L1-P, D1-P, D2-P	2	----	----	----	2292 475	2292 475
	Front Seat Side Shield to Seat Frame						
	D1, D2	2	2419 957	2419 957	2419 957	2419 957	2419 957

★ Indicates use as required.

⊠ Indicates parts not listed in any previous parts book.  
Jan. 3, 1964 Supersedes Dec. 14, 1962.

Printed in U.S.A.

Prices and specifications subject to change without notice.  
Right and left part numbers are on same line,  
first number is right, second number is left.

\* Indicates change or addition.



CODE	REMARKS	PER CAR	SED.	SP. 4 D.	SUB.	SP. CL. CP.	CV. CP.
23-109-3	BACK, Rear Seat						
	L1						
	(code 801)	1	2296 784				
	(w/heavy duty spring)	1	2296 788				
	(code 803)	1	2296 785				
	(w/heavy duty spring)	1	2296 789				
	(code 805)	1	2296 786				
	(w/heavy duty spring)	1	2296 790				
	(code 808)	1	2296 787				
	(w/heavy duty spring)	1	2296 791				
	L1 (sub. 2nd. seat)						
	(code 851)	1	----	----	2296 900		
	(code 853)	1	----	----	2296 901		
	(code 855)	1	----	----	2296 902		
	(code 858)	1	----	----	2296 903		
	(code 894) (4 D.)	1	2296 671				
	L1-H						
	(code 831)	1	2415 028				
	(code 833)	1	2415 029				
	(code 835)	1	2415 030				
	(code 838)	1	2415 031				
	L1-L, L1-H						
	(code 871)	1	2415 706	----	2415 366	----	2433 070
	(code 873)	1	2415 707	----	2415 367	----	2433 071
	(code 875)	1	2415 708	----	2415 368	----	2433 072
	(code 878)	1	----	----	2415 369	----	2433 073
	L1-P						
	(code 891)	1	----	----	----	2415 786	2433 102
	(code 893)	1	----	----	----	2415 787	2433 103
	(code 895)	1	----	----	----	2415 788	2433 104
	(code 898)	1	----	----	----	2415 789	2433 105
	D1-L, D2-L						
	(code 501)	1	2415 244				
	(w/heavy duty spring)	1	2415 248				
	(code 503)	1	2415 245				
	(w/heavy duty spring)	1	2415 249				
	(code 505)	1	2415 246				
	(w/heavy duty spring)	1	2415 250				
	(code 508)	1	2415 247				
	(w/heavy duty spring)	1	2415 251				
	(code 561) (Sub. 2nd seat)	1	2137 836	----	2137 898		
	(police)(Sub. 3rd seat)	1	2137 942	----	2137 914		
	(code 563)	1	2137 837				
	(code 694)	1	2415 157				
	(w/heavy duty spring)	1	2415 158				
	D1-M, D2-M						
	(code 521)	1	2431 160	----	----	2431 160	
	(w/heavy duty spring)	1	2431 165	----	----	2431 165	
	(code 523)	1	2431 161	----	----	2431 161	
	(w/heavy duty spring)	1	2431 166	----	----	2431 166	
	(code 525)	1	2431 162	----	----	2431 162	
	(w/heavy duty spring)	1	2431 167	----	----	2431 167	
	(code 526)	1	2431 163	----	----	2431 163	
	(w/heavy duty spring)	1	2431 168	----	----	2431 168	
	(code 528)	1	2431 164	----	----	2431 164	
	(w/heavy duty spring)	1	2431 169	----	----	2431 169	
	D1-H, D2-H						
	(code 541)	1	2431 420				
	(code 543)	1	2431 421				
	(code 545)	1	2431 422				

★ Indicates use as required.

⊠ Indicates parts not listed in any previous parts book.

Right and left part numbers are on same line, first number is right, second number is left.

\* Indicates change or addition.

Printed in U.S.A.

Prices and specifications subject to change without notice.

Jan. 3, 1964 Supersedes Dec. 14, 1962.

## 1963 PASSENGER CAR PARTS CATALOG

INTERIOR TRIM

CODE	REMARKS	PER CAR	SED.	SP. 4 D.	SUB.	SP. CL. CP.	CV. CP.
23-109-3	BACK, Rear Seat-Cont'd						
	D1-H, D2-H						
	(code 546)	1	2431 423				
	(code 548)	1	2431 424				
	(code 594)	1	2433 004				
	(code 684)	1	2137 669				
	A3-L						
	(code 571)	1	2136 984	-----	-----	2137 174	
	(code 572)	1	2136 985	-----	-----	2137 175	
	(code 573)	1	2136 986	-----	-----	2137 176	
	(code 575)	1	2136 987	-----	-----	2137 177	
	(code 578)	1	2136 988	-----	-----	2137 178	
	A3 (2nd. seat)						
	(code 563)	1	*2137 837	-----	E2137 899		
	(code 565)	1	E2137 838	-----	E2137 900		
	(code 568)	1	E2137 839	-----	E2137 901		
	(police)						
	(code 563)	1	E2137 943				
	(code 565)	1	E2137 944				
	(code 568)	1	E2137 945				
	(code 584)	1	E2137 663				
	(3rd. seat)						
	(code 563)	1	-----	-----	E2137 915		
	(code 565)	1	-----	-----	E2137 916		
	(code 568)	1	-----	-----	E2137 917		
	D1-L, D2-L (spring and cover)						
	(code 601) (2nd. seat)	1	-----	-----	2415 446		
	(code 601) (3rd. seat)	1	-----	-----	2415 478		
	(code 603) (2nd. seat)	1	-----	-----	2415 447		
	(code 603) (3rd. seat)	1	-----	-----	2415 479		
	(code 605) (2nd. seat)	1	-----	-----	2415 448		
	(code 605) (3rd. seat)	1	-----	-----	2415 480		
	(code 608) (2nd. seat)	1	-----	-----	2415 449		
	(code 608) (3rd. seat)	1	-----	-----	2415 481		
	D1-L, D2-L, D1-M, D2-M						
	(codes 611, 621)	1	2415 528				
	(w/heavy duty spring)	1	2415 922				
	(codes 613, 623)	1	2415 529				
	(w/heavy duty spring)	1	2415 923				
	D1-M, D2-M (spring and cover)						
	(code 621) (2nd. seat)	1	-----	-----	2431 036		
	(code 621) (3rd. seat)	1	-----	-----	2431 082		
	(code 623) (2nd. seat)	1	-----	-----	2431 037		
	(code 623) (3rd. seat)	1	-----	-----	2431 083		
	(code 625) (2nd. seat)	1	-----	-----	2431 038		
	(code 625) (3rd. seat)	1	-----	-----	2431 084		
	(code 626) (2nd. seat)	1	-----	-----	2431 039		
	(code 626) (3rd. seat)	1	-----	-----	2431 085		
	(code 628) (2nd. seat)	1	-----	-----	2431 040		
	(code 628) (3rd. seat)	1	-----	-----	2431 086		
	D1-H, D2-H						
	(code 641)	1	2431 680	2431 680	-----	2431 680	2431 865
	(code 643)	1	2431 681	2431 681	-----	2431 681	2431 866
	(code 645)	1	2431 682	2431 682	-----	2431 682	2431 867
	(code 646)	1	2431 683	2431 683	-----	2431 683	2431 868
	(code 648)	1	2431 684	2431 684	-----	2431 684	2431 869
	D2-P						
	(code 651)	1	-----	-----	-----	2431 845	2431 875
	(code 653)	1	-----	-----	-----	2431 846	2431 876
	(code 655)	1	-----	-----	-----	2431 847	2431 877
	(code 656)	1	-----	-----	-----	2431 848	2431 878
	(code 658)	1	-----	-----	-----	2431 849	2431 879

★ Indicates use as required.

E Indicates parts not listed in any previous parts book.  
Jan. 3, 1964 Supersedes Dec. 14, 1962.

Printed in U.S.A.

Prices and specifications subject to change without notice.  
Right and left part numbers are on same line,  
first number is right, second number is left.

\* Indicates change or addition.

CODE	REMARKS	PER CAR	SED.	SP. 4D.	SUB.	SP. CL. CP.	CV. CP.
23-109-3	BACK, Rear Seat-Cont'd A3-L						
	(code 671)	1	----	2137 320	----	----	2137 783
	(code 672)	1	----	2137 321	----	----	2137 784
	(code 673)	1	----	2137 322	----	----	2137 785
	(code 675)	1	----	2137 323	----	----	2137 786
	(code 678)	1	----	2137 324	----	----	2137 787
	(code 671) (2nd. seat)	1	----	----	2137 482		
	(code 671) (3rd. seat)	1	----	----	2137 512		
	(code 672) (2nd. seat)	1	----	----	2137 483		
	(code 672) (3rd. seat)	1	----	----	2137 513		
	(code 673) (2nd. seat)	1	----	----	2137 484		
	(code 673) (3rd. seat)	1	----	----	2137 514		
	(code 675) (2nd. seat)	1	----	----	2137 485		
	(code 675) (3rd. seat)	1	----	----	2137 515		
	(code 678) (2nd. seat)	1	----	----	2137 486		
	(code 678) (3rd. seat)	1	----	----	2137 516		
	(second seat back spring attaching nut)	3	----	----	6000 234		
23-109-4	COVER, Rear Seat Back L1						
	(code 801)	1	2296 780				
	(code 803)	1	2296 781				
	(code 805)	1	2296 782				
	(code 808)	1	2296 783				
	(code 831)	1	2415 016				
	(code 833)	1	2415 017				
	(code 835)	1	2415 018				
	(code 838)	1	2415 019				
	L1 (Sub., 2nd seat)						
	(code 851)	1	----	----	2296 896		
	(code 853)	1	----	----	2296 897		
	(code 855)	1	----	----	2296 898		
	(code 858)	1	----	----	2296 899		
	(code 871)	1	----	----	2415 358		
	(code 873)	1	----	----	2415 359		
	(code 875)	1	----	----	2415 360		
	(code 878)	1	----	----	2415 361		
	L1-L, L1-H						
	(code 871)	1	2415 696	----	----	----	2433 058
	(code 873)	1	2415 697	----	----	----	2433 059
	(code 875)	1	2415 698	----	----	----	2433 060
	(code 878)	1	----	----	----	----	2433 061
	L1-P						
	(code 891)	1	----	----	----	2415 782	2433 098
	(code 893)	1	----	----	----	2415 783	2433 099
	(code 895)	1	----	----	----	2415 784	2433 100
	(code 898)	1	----	----	----	2415 785	2433 101
	D1, D2						
	(code 501)	1	2415 236				
	(code 503)	1	2415 237				
	(code 505)	1	2415 238				
	(code 508)	1	2415 239				
	(code 521)	1	2431 155	2431 155	----	2431 155	
	(code 523)	1	2431 156	2431 156	----	2431 156	
	(code 525)	1	2431 157	2431 157	----	2431 157	
	(code 526)	1	2431 158	2431 158	----	2431 158	
	(code 528)	1	2431 159	2431 159	----	2431 159	

★ Indicates use as required.  
 ☐ Indicates parts not listed in any previous parts book.  
 Right and left part numbers are on same line,  
 first number is right, second number is left.  
 \* Indicates change or addition.

Printed in U.S.A.  
 Prices and specifications subject to change without notice.  
 Jan. 3, 1964 Supersedes Dec. 14, 1962.

# 1963 PASSENGER CAR PARTS CATALOG

CODE	REMARKS	PER CAR	SED.	SP. 4 D.	SUB.	SP. CL. CP.	CV. CP.
23-109-4	COVER, Rear Seat Back-Cont'd						
	D1-L, D2-L						
	(code 594)	1	2433 003				
	(codes 611, 621) (4 D.)	1	2415 088				
	(codes 613, 623) (4 D.)	1	2415 089				
	(code 694)	1	2415 156				
	D1-H, D2-H						
	(code 541)	1	2431 395				
	(code 543)	1	2431 396				
	(code 545)	1	2431 397				
	(code 546)	1	2431 398				
	(code 548)	1	2431 399				
	D1, D2 (Sub. 2nd. seat)						
	(code 601)	1	----	----		2415 438	
	(code 621)	1	----	----		2431 015	
	(code 623)	1	----	----		2431 016	
	(code 625)	1	----	----		2431 017	
	(code 626)	1	----	----		2431 018	
	(code 628)	1	----	----		2431 019	
	D1, D2 (Sub. 3rd. seat)						
	(code 621)	1	----	----		2431 061	
	(code 623)	1	----	----		2431 062	
	(code 625)	1	----	----		2431 063	
	(code 626)	1	----	----		2431 064	
	(code 628)	1	----	----		2431 065	
	D1-L, D2-L						
	(code 601) (2nd. seat)	1	----	----		2415 438	
	(code 601) (3rd. seat)	1	----	----		2415 470	
	(code 603) (2nd. seat)	1	----	----		2415 439	
	(code 603) (3rd. seat)	1	----	----		2415 471	
	(code 605) (2nd. seat)	1	----	----		2415 440	
	(code 605) (3rd. seat)	1	----	----		2415 472	
	(code 608) (2nd. seat)	1	----	----		2415 441	
	(code 608) (3rd. seat)	1	----	----		2415 473	
	D1-H, D2-H						
	(code 641)	1	2431 665	----	----	2431 665	2431 825
	(code 643)	1	2431 666	----	----	2431 666	2431 826
	(code 645)	1	2431 667	----	----	2431 667	2431 827
	(code 646)	1	2431 668	----	----	2431 668	2431 828
	(code 648)	1	2431 669	----	----	2431 669	2431 829
	D2-P						
	(code 651)	1	----	----	----	2431 840	2431 870
	(code 653)	1	----	----	----	2431 841	2431 871
	(code 655)	1	----	----	----	2431 842	2431 872
	(code 656)	1	----	----	----	2431 843	2431 873
	(code 658)	1	----	----	----	2431 844	2431 874
	A3-E						
	(code 561) (2nd. seat)	1	2137 840	----	----	2137 902	
	(code 561) (3rd. seat)	1	----	----	----	2137 918	
	(code 563) (2nd. seat)	1	2137 841	----	----	2137 903	
	(code 563) (3rd. seat)	1	----	----	----	2137 919	
	(code 565) (2nd. seat)	1	2137 842	----	----	2137 904	
	(code 565) (3rd. seat)	1	----	----	----	2137 920	
	(code 568) (2nd. seat)	1	2137 843	----	----	2137 905	
	(code 568) (3rd. seat)	1	----	----	----	2137 921	
	A3-L						
	(code 571)	1	2136 989	----	----	2137 179	
	(code 572)	1	2136 990	----	----	2137 180	
	(code 573)	1	2136 991	----	----	2137 181	
	(code 575)	1	2136 992	----	----	2137 182	
	(code 578)	1	2136 993	----	----	2137 183	
	(code 584)	1	2137 664	----	----		

★ Indicates use as required.  
 ☐ Indicates parts not listed in any previous parts book.  
 Jan. 3, 1964 Supersedes Dec. 14, 1962.

Printed in U.S.A.  
 Prices and specifications subject to change without notice.  
 Right and left part numbers are on same line,  
 first number is right, second number is left.  
 \* Indicates change or addition.

CODE	REMARKS	PER CAR	SED.	SP. 4 D.	SUB.	SP. CL. CP.	CV. CP.
23-109-4	COVER, Rear Seat Back - Cont'd A3-L						
	(code 671) (2nd. seat)	1	----	2137 325	2137 487	----	2137 442
	(3rd. seat)	1	----	----	2137 517	----	
	(code 672) (2nd. seat)	1	----	2137 326	2137 488	----	2137 443
	(3rd. seat)	1	----	----	2137 518	----	
	(code 673) (2nd. seat)	1	----	2137 327	2137 489	----	2137 444
	(3rd. seat)	1	----	----	2137 519	----	
	(code 675) (2nd. seat)	1	----	2137 328	2137 490	----	2137 445
	(3rd. seat)	1	----	----	2137 520	----	
	(code 678) (2nd. seat)	1	----	2137 329	2137 491	----	2137 446
	(3rd. seat)	1	----	----	2137 521	----	
	(code 684) (2nd. seat)	1	2137 670				
23-109-5	INSERT or COVER, Rear Seat Back Rear Panel						
	D1, D2 (Sub. 2nd. seat)						
	(codes 601, 621) (blue)	1	----	----	2297 561		
	(codes 603, 623) (tan)	1	----	----	2297 562		
	(codes 605, 625) (red)	1	----	----	E1804 TR6		
	(codes 608, 628) (turquoise)	1	----	----	2297 565		
	(code 626) (black)	1	----	----	2297 564		
	D1, D2 (Sub. 3rd. seat)						
	(codes 601, 621) (blue)	1	----	----	2297 567		
	(codes 603, 623) (tan)	1	----	----	2297 568		
	(codes 605, 625) (red)	1	----	----	E1805 TR6		
	(codes 608, 628) (turquoise)	1	----	----	2297 571		
	(code 626) (black)	1	----	----	2297 570		
	D1, D2 (Sub. 3rd. seat) (back support panel)						
	(codes 601, 621) (blue)	1	----	----	2297 591		
	(codes 603, 623) (tan)	1	----	----	2297 592		
	(codes 605, 625) (red)	1	----	----	2297 593		
	(codes 608, 628) (turquoise)	1	----	----	2297 595		
	(code 626) (black)	1	----	----	2297 594		
	D2-P (upper panel) (paint as required)	1	----	----	----	----	2413 817
	A3 (Sub. 2nd. seat)						
	(codes 561, 671) (blue)	1	----	----	2180 832		
	(code 672) (green)	1	----	----	2181 389		
	(codes 563, 673) (tan)	1	----	----	2181 390		
	(codes 565, 675) (red)	1	----	----	2181 391		
	(codes 568, 678) (turquoise)	1	----	----	2181 392		
	A3 (Sub. 3rd. seat)						
	(codes 561, 671) (blue)	1	----	----	2180 834		
	(code 672) (green)	1	----	----	2181 397		
	(codes 563, 673) (tan)	1	----	----	2181 398		
	(codes 565, 675) (red)	1	----	----	2181 399		
	(codes 568, 678) (turquoise)	1	----	----	2181 400		
23-109-35	CUSHION, Rear Seat L1-L						
	(code 801)	1	2296 764				
	(w/airfoam pad)	1	*2296 772				
	(code 803)	1	2296 765				
	(w/heavy duty spring)	1	2296 773				
	(code 805)	1	2296 766				
	(w/heavy duty spring)	1	2296 774				
	(code 808)	1	2296 767				
	(w/heavy duty spring)	1	2296 775				

★ Indicates use as required.  
 □ Indicates parts not listed in any previous parts book.  
 Right and left part numbers are on same line,  
 first number is right, second number is left.  
 \* Indicates change or addition.

# 1963 PASSENGER CAR PARTS CATALOG

INTERIOR TRIM

CODE	REMARKS	PER CAR	SED.	SP. 4 D.	SUB.	SP. CL. CP.	CV. CP.
23-109-35	CUSHION, Rear Seat - Cont'd						
	L1 (Sub. 2nd. seat)						
	(code 851)	1	----	----	2296 892		
	(code 853)	1	----	----	2296 893		
	(code 855)	1	----	----	2296 894		
	(code 858)	1	----	----	2296 895		
	(code 894) (4 D.)	1	2296 669				
	L1-H						
	(code 831)	1	2415 012				
	(code 833)	1	2415 013				
	(code 835)	1	2415 014				
	(code 838)	1	2415 015				
	L1-L, L1-H						
	(code 871)	1	2415 693				
	(code 873)	1	2415 694				
	(code 875)	1	2415 695				
	L1-H						
	(code 871)	1	----	----	----	----	2433 050
	(code 873)	1	----	----	----	----	2433 051
	(code 875)	1	----	----	----	----	2433 052
	(code 878)	1	----	----	----	----	2433 053
	L1-H (spring and cover)						
	(code 871) (2nd. seat)	1	----	----	2415 354		
	(code 873) (2nd. seat)	1	----	----	2415 355		
	(code 875) (2nd. seat)	1	----	----	2415 356		
	(code 878) (2nd. seat)	1	----	----	2415 357		
	L1-P						
	(code 891)	1	----	----	----	2415 770	2433 086
	(code 893)	1	----	----	----	2415 771	2433 087
	(code 895)	1	----	----	----	2415 772	2433 088
	(code 898)	1	----	----	----	2415 773	2433 089
	(w/airfoam pad)	1	----	----	----	2431 095	
	D1-L, D2-L						
	(code 501)	1	2415 228				
	(w/heavy duty spring)	1	2415 232				
	(code 503)	1	2415 229				
	(w/heavy duty spring)	1	2415 233				
	(code 505)	1	2415 230				
	(w/heavy duty spring)	1	2415 234				
	(code 508)	1	2415 231				
	(w/heavy duty spring)	1	2415 235				
	(code 594)	1	2433 001				
	(w/airfoam pad)	1	2433 002				
	(code 611)	1	E2433 304				
	(w/airfoam pad)	1	2433 306				
	(w/heavy duty spring)	1	E2433 308				
	(code 613)	1	E2433 305				
	(w/heavy duty spring)	1	E2433 309				
	(code 694)	1	2415 152				
	(w/airfoam pad)	1	2415 153				
	(w/heavy duty spring and airfoam pad)	1	2415 155				
	(w/heavy duty spring)	1	2415 154				
	D1-M, D2-M						
	(code 521)	1	E2433 215	----	----	E2433 215	
	(w/airfoam pad)	1	2433 220	----	----	2433 220	
	(w/heavy duty spring)	1	E2433 225	----	----	E2433 225	
	(code 523)	1	E2433 216	----	----	E2433 216	
	(w/airfoam pad)	1	2433 221	----	----	2433 221	
	(w/heavy duty spring)	1	E2433 226	----	----	E2433 226	

★ Indicates use as required.

E Indicates parts not listed in any previous parts book.  
Jan. 3, 1964 Supersedes Dec. 14, 1962.

Prices and specifications subject to change without notice.  
Right and left part numbers are on same line,  
first number is right, second number is left.

\* Indicates change or addition.

CODE	REMARKS	PER CAR	SED.	SP. 4 D.	SUB.	SP. CL. CP.	CV. CP.
23-109-35	CUSHION, Rear Seat-Cont'd						
	D1-M, D2-M						
	(code 525)	1	E2433 217	----	----	E2433 217	
	(w/airfoam pad)	1	2433 222	----	----	2433 222	
	(w/heavy duty spring)	1	E2433 227	----	----	E2433 227	
	(code 526)	1	E2433 218	----	----	E2433 218	
	(w/airfoam pad)	1	2433 223	----	----	2433 223	
	(w/heavy duty spring)	1	E2433 228	----	----	E2433 228	
	(code 528)	1	E2433 219	----	----	E2433 219	
	(w/airfoam pad)	1	2433 224	----	----	2433 224	
	(w/heavy duty spring)	1	E2433 229	----	----	E2433 229	
	D1-H, D2-H						
	(code 541)	1	2431 385				
	(w/airfoam pad)	1	2431 390				
	(code 543)	1	2431 386				
	(w/airfoam pad)	1	2431 391				
	(code 545)	1	2431 387				
	(w/airfoam pad)	1	2431 392				
	(code 546)	1	2431 388				
	(w/airfoam pad)	1	2431 393				
	(code 548)	1	2431 389				
	(w/airfoam pad)	1	2431 394				
	D1-L, D2-L						
	(code 601) (2nd. seat)	1	----	----	2415 434		
	(3rd. seat)	1	----	----	2415 466		
	(code 603) (2nd. seat)	1	----	----	2415 435		
	(3rd. seat)	1	----	----	2415 467		
	(code 605) (2nd. seat)	1	----	----	2415 436		
	(3rd. seat)	1	----	----	2415 468		
	(code 608) (2nd. seat)	1	----	----	2415 437		
	(3rd. seat)	1	----	----	2415 469		
	D1-M, D2-M						
	(code 621) (2nd. seat)	1	----	----	E2433 285		
	(w/airfoam pad)	1	2433 306				
	(w/heavy duty spring)	1	E2433 308				
	(3rd. seat)	1	----	----	E2433 295		
	(code 623) (2nd. seat)	1	E2433 304	----	E2433 286		
	(w/heavy duty spring)	1	E2433 309				
	(3rd. seat)	1	----	----	E2433 296		
	(code 625) (2nd. seat)	1	----	----	E2433 287		
	(3rd. seat)	1	----	----	E2433 297		
	(code 626) (2nd. seat)	1	----	----	E2433 288		
	(3rd. seat)	1	----	----	E2433 298		
	(code 628) (2nd. seat)	1	----	----	E2433 289		
	(3rd. seat)	1	----	----	E2433 299		
	(code 641)	1	2431 655	2431 655	----	2431 655	2431 805
	D1-H, D2-H						
	(w/airfoam pad)	1	2431 660	2431 660	----	2431 660	2431 820
	(code 643)	1	2431 656	2431 656	----	2431 656	2431 806
	(w/airfoam pad)	1	2431 661	2431 661	----	2431 661	2431 821
	(code 645)	1	2431 657	2431 657	----	2431 657	2431 807
	(w/airfoam pad)	1	2431 662	2431 662	----	2431 662	2431 822
	(code 646)	1	2431 658	2431 658	----	2431 658	2431 808
	(w/airfoam pad)	1	2431 663	2431 663	----	2431 663	2431 823
	(code 648)	1	2431 659	2431 659	----	2431 659	2431 809
	(w/airfoam pad)	1	2431 664	2431 664	----	2431 664	2431 824
	D2-P						
	(code 651)	1	----	----	----	2431 835	2431 860
	(code 653)	1	----	----	----	2431 836	2431 861
	(code 655)	1	----	----	----	2431 837	2431 862
	(code 656)	1	----	----	----	2431 838	2431 863
	(code 658)	1	----	----	----	2431 839	2431 864

★ Indicates use as required.

E Indicates parts not listed in any previous parts book.

Right and left part numbers are on same line, first number is right, second number is left.

\* Indicates change or addition.

Printed in U.S.A.  
Prices and specifications subject to change without notice.  
Jan. 3, 1964 Supersedes Jan. 25, 1963.

## 1963 PASSENGER CAR PARTS CATALOG

INTERIOR TRIM

CODE	REMARKS	PER CAR	SED.	SP. 4 D.	SUB.	SP. CL. CP.	CV. CP.
23-109-35	CUSHION, Rear Seat-Cont'd A3-E						
	(code 561) (2nd. seat)	1	2137 844	----	2137 906		
	(w/airfoam pad)	1	2137 877				
	(w/heavy duty spring and rubber pad)	1	2137 970				
	(police)	1	2137 984				
	(3rd. seat)	1	----	----	2137 922		
	(code 563) (2nd. seat)	1	2137 845	----	2137 907		
	(w/airfoam pad)	1	2137 878				
	(w/heavy duty spring and rubber pad)	1	2137 971				
	(police)	1	2137 985				
	(3rd. seat)	1	----	----	2137 923		
	(code 565) (2nd. seat)	1	2137 846	----	2137 908		
	(w/airfoam pad)	1	2137 879				
	(w/heavy duty spring and rubber pad)	1	2137 972				
	(police)	1	2137 986				
	(3rd. seat)	1	----	----	2137 924		
	(code 568) (2nd. seat)	1	2137 847	----	2137 909		
	(w/airfoam pad)	1	2137 880				
	(w/heavy duty spring and rubber pad)	1	2137 973				
	(police)	1	2137 987				
	(3rd. seat)	1	----	----	E2137 925		
	(code 584)	1	2137 665				
	(w/airfoam pad)	1	2137 667				
	(code 684)	1	2137 671				
	(w/airfoam pad)	1	2137 696				
A3-L							
	(code 571)	1	2137 000	----	----	2137 189	
	(w/airfoam pad)	1	2137 046	----	----	2137 234	
	(w/heavy duty spring and airfoam pad)	1	2137 597				
	(police)	1	2137 592				
	(code 572)	1	2137 001	----	----	2137 190	
	(w/airfoam pad)	1	2137 047	----	----	2137 235	
	(w/heavy duty spring and airfoam pad)	1	2137 598				
	(police)	1	2137 593				
	(code 573)	1	2137 002	----	----	2137 191	
	(w/airfoam pad)	1	2137 048	----	----	2137 236	
	(w/heavy duty spring and airfoam pad)	1	2137 599				
	(police)	1	2137 594				
	(code 575)	1	2137 003	----	----	2137 192	
	(w/airfoam pad)	1	2137 049	----	----	2137 237	
	(w/heavy duty spring and airfoam pad)	1	2137 600				
	(police)	1	2137 595				
	(code 578)	1	2137 004	----	----	2137 193	
	(w/airfoam pad)	1	2137 050	----	----	2137 238	
	(w/heavy duty spring and airfoam pad)	1	2137 601				
	(police)	1	2137 596				
	(code 671) (2nd. seat)	1	----	2137 335	2137 497	----	2137 452
	(3rd. seat)	1	----	----	2137 527		
	(code 672) (2nd. seat)	1	----	2137 336	2137 498	----	2137 453
	(3rd. seat)	1	----	----	2137 528		
	(code 673) (2nd. seat)	1	----	2137 337	2137 499	----	2137 454
	(3rd. seat)	1	----	----	2137 529		

★ Indicates use as required.

☐ Indicates parts not listed in any previous parts book.  
Jan. 3, 1964 Supersedes Dec. 14, 1962.

Printed in U.S.A.

Prices and specifications subject to change without notice.

Right and left part numbers are on same line,  
first number is right, second number is left.

\* Indicates change or addition.



CODE	REMARKS	PER CAR	SED.	SP. 4D.	SUB.	SP. CL. CP.	CV. CP.
23-109-35	CUSHION, Rear Seat - Cont'd A3-L						
	(code 675) (2nd. seat)	1	----	2137 338	2137 500	----	2137 455
	(code 678) (3rd. seat)	1	----	----	2137 530	----	
	(code 678) (2nd. seat)	1	----	2137 339	2137 501	----	2137 456
	(code 678) (3rd. seat)	1	----	----	2137 531	----	
23-109-36	COVER, Rear Seat Cushion L1						
	(code 801)	1	2296 760				
	(code 803)	1	2296 761				
	(code 805)	1	2296 762				
	(code 808)	1	2296 763				
	(code 831)	1	E2433 386				
	(code 833)	1	2415 001				
	(code 835)	1	2415 002				
	(code 838)	1	2415 003				
	(code 851)	1	----	----	2296 888		
	(code 853)	1	----	----	2296 889		
	(code 855)	1	----	----	2296 890		
	(code 858)	1	----	----	2296 891		
	(code 871)	1	2415 690	----	2415 342	----	2433 042
	(code 873)	1	*2415 691	----	2415 343	----	2433 043
	(code 875)	1	*2415 692	----	2415 344	----	2433 044
	(code 878)	1	----	----	2415 345	----	2433 045
	L1-P						
	(code 891)	1	----	----	----	2415 766	2433 082
	(code 893)	1	----	----	----	2415 767	2433 083
	(code 895)	1	----	----	----	2415 768	2433 084
	(code 898)	1	----	----	----	2415 769	2433 085
	D1-H, D2-H						
	(code 541)	1	2431 380				
	(code 543)	1	2431 381				
	(code 545)	1	2431 382				
	(code 546)	1	2431 383				
	(code 548)	1	2431 384				
	D1, D2						
	(code 501)	1	2415 224				
	(code 503)	1	2415 225				
	(code 505)	1	2415 226				
	(code 508)	1	2415 227				
	(code 521)	1	E2433 205	E2433 205	----	E2433 205	
	(w/airfoam pad)	1	2433 210	----	----	2433 210	
	(code 523)	1	E2433 206	E2433 206	----	E2433 206	
	(w/airfoam pad)	1	2433 211	----	----	2433 211	
	(code 525)	1	E2433 207	E2433 207	----	E2433 207	
	(w/airfoam pad)	1	2433 212	----	----	2433 212	
	(code 526)	1	E2433 208	E2433 208	----	E2433 208	
	(w/airfoam pad)	1	2433 213	----	----	2433 213	
	(code 528)	1	E2433 209	E2433 209	----	E2433 209	
	(w/airfoam pad)	1	2433 214	----	----	2433 214	
	(code 594)	1	2433 000				
	(code 601) (2nd. seat)	1	----	----	2415 426		
	(code 601) (3rd. seat)	1	----	----	2415 458		
	(code 603) (2nd. seat)	1	----	----	2415 427		
	(code 603) (3rd. seat)	1	----	----	2415 459		
	(code 605) (2nd. seat)	1	----	----	2415 428		
	(code 605) (3rd. seat)	1	----	----	2415 460		
	(code 608) (2nd. seat)	1	----	----	2415 429		
	(code 608) (3rd. seat)	1	----	----	2415 461		

★ Indicates use as required.

E Indicates parts not listed in any previous parts book.  
Right and left part numbers are on same line,  
first number is right, second number is left.

\* Indicates change or addition.

Printed in U.S.A.

Prices and specifications subject to change without notice.

## 1963 PASSENGER CAR PARTS CATALOG

INTERIOR TRIM

CODE	REMARKS	PER CAR	SED.	SP. 4 D.	SUB.	SP. CL. CP.	CV. CP.
23-109-36	COVER, Rear Seat Cushion-Cont'd D1, D2						
	(codes 611,621) (2nd. seat)	1	2415 522	----	E2433 280		
	(w/airfoam pad)	1	2433 302				
	(3rd seat)	1	----	----	E2433 290		
	(codes 613,623) (2nd. seat)	1	2415 523	----	E2433 281		
	(w/airfoam pad)	1	2433 303				
	(3rd. seat)	1	----	----	E2433 291		
	(code 625) (2nd. seat)	1	----	----	E2433 282		
	(3rd. seat)	1	----	----	E2433 292		
	(code 626) (2nd. seat)	1	----	----	E2433 283		
	(3rd. seat)	1	----	----	E2433 293		
	(code 628) (2nd. seat)	1	----	----	E2433 284		
	(3rd. seat)	1	----	----	E2433 294		
	(code 694)	1	2415 151	----	2415 151		
	D1-H, D2-H						
	(code 641)	1	2431 650	2431 650	----	2431 650	2431 760
	(code 643)	1	2431 651	2431 651	----	2431 651	2431 761
	(code 645)	1	2431 652	2431 652	----	2431 652	2431 762
	(code 646)	1	2431 653	2431 653	----	2431 653	2431 763
	(code 648)	1	2431 654	2431 654	----	2431 654	2431 764
	D2-P						
	(code 651)	1	----	----	----	2431 830	2431 855
	(code 653)	1	----	----	----	2431 831	2431 856
	(code 655)	1	----	----	----	2431 832	2431 857
	(code 656)	1	----	----	----	2431 833	2431 858
	(code 658)	1	----	----	----	2431 834	2431 859
	A3-E						
	(code 561) (2nd. seat)	1	2137 848	----	2137 910		
	(3rd. seat)	1	----	----	2137 926		
	(code 563) (2nd. seat)	1	2137 849	----	2137 911		
	(3rd. seat)	1	----	----	2137 927		
	(code 565) (2nd. seat)	1	2137 850	----	2137 912		
	(3rd. seat)	1	----	----	2137 928		
	(code 568) (2nd. seat)	1	2137 851	----	2137 913		
	(3rd. seat)	1	----	----	2137 929		
	A3-L						
	(code 571)	1	2137 005	----	----	2137 194	
	(code 572)	1	2137 006	----	----	2137 195	
	(code 573)	1	2137 007	----	----	2137 196	
	(code 575)	1	2137 008	----	----	2137 197	
	(code 578)	1	2137 009	----	----	2137 198	
	(code 671) (2nd. seat)	1	----	2137 340	2137 502	----	2137 457
	(3rd. seat)	1	----	----	2137 532		
	(code 672) (2nd. seat)	1	----	2137 341	2137 503	----	2137 458
	(3rd. seat)	1	----	----	2137 533		
	(code 673) (2nd. seat)	1	----	2137 342	2137 504	----	2137 459
	(3rd. seat)	1	----	----	2137 534		
	(code 675) (2nd. seat)	1	----	2137 343	2137 505	----	2137 460
	(3rd. seat)	1	----	----	2137 535		
	(code 678) (2nd. seat)	1	----	2137 344	2137 506	----	2137 461
	(3rd. seat)	1	----	----	2137 536		
	(3rd. seat cushion spring attaching nut)	3	----	----	6000 234		
	(code 584)	1	2137 666				
	(code 684)	1	2137 672				
23-109-38	CATCH, 3rd. seat Cushion D1, D2	2	----	----	2270 834		

★ Indicates use as required.

☐ Indicates parts not listed in any previous parts book.

Jan. 3, 1964 Supersedes Dec. 14, 1962.

Page IT-156B

Printed in U.S.A.  
Prices and specifications subject to change without notice.Right and left part numbers are on same line,  
first number is right, second number is left.

\* Indicates change or addition.

CODE	REMARKS	PER CAR	SED.	SP. 4 D.	SUB.	SP. CL. CP.	CV. CP.
23-109-38	RETAINER, Center Floor Pan D1, D2						
	Rear Seat Cushion	2	1810 037	1810 037	2422 981	1810 037	1810 037
	Rear Floor Pan 3rd. Seat Cushion, Front	2	----	----	2251 674		
	Rear	2	----	----	2251 675		
23-109-40	INSERT, 3rd. Seat Cushion Panel A3						
	(codes 561, 671)	1	----	----	2180 833		
	(code 672)	1	----	----	2181 393		
	(codes 563, 673)	1	----	----	2181 394		
	(codes 565, 675)	1	----	----	2181 395		
	(codes 568, 678)	1	----	----	2181 396		
23-111-31	RETAINER, Folding Top Header Outer Panel Tacking Strip A3-L	1	----	----	----	----	1952 194
23-111-37	STRIP, Folding Top Bow Tacking L1	2	----	----	----	----	*2424 591
	D1, D2, A3 (No. 1 and No. 2 bow)	1	----	----	----	----	*1950 509
	(No. 3 bow)	1	----	----	----	----	*2424 607
23-112-4	RETAINER, Folding Top Header Top Material L1 (in white)	1	----	----	----	----	2424 262-3
23-112-12	BOOT, Folding Top Dust L1						
	(codes 871, 891) (blue)	1	----	----	----	----	2432 364
	(codes 873, 893) (tan)	1	----	----	----	----	2432 365
	(codes 875, 895) (red)	1	----	----	----	----	2432 366
	(codes 878, 898) (turquoise)	1	----	----	----	----	2432 367
D2-H, D2-P (w/4 pocket panel fasteners)	(code 641, 651) (blue)	1	----	----	----	----	E2432 952
	(code 643, 653) (tan)	1	----	----	----	----	E2432 953
	(code 645, 655) (red)	1	----	----	----	----	E2432 954
	(code 646) (alabaster)	1	----	----	----	----	E2432 955
	(code 648, 658) (turquoise)	1	----	----	----	----	E2432 956
	(code 656) (black)	1	----	----	----	----	*2432 957
D2-H, D2-P (w/8 pocket panel fasteners)	(codes 641, 651)	1	----	----	----	----	E2432 990
	(codes 643, 653)	1	----	----	----	----	E2432 991
	(codes 645, 655)	1	----	----	----	----	E2432 992
	(code 646)	1	----	----	----	----	E2432 993
	(codes 648, 658)	1	----	----	----	----	E2432 994
	(code 656)	1	----	----	----	----	E2432 995
A3-L	(code 671)	1	----	----	----	----	E2182 069
	(code 672)	1	----	----	----	----	E2182 070
	(code 673)	1	----	----	----	----	E2182 071
	(code 675)	1	----	----	----	----	E2182 072
	(code 678)	1	----	----	----	----	E2182 073
	(cap fastener)	1	----	----	----	----	*6000 434
23-112-18	RETAINER, Channel Rear Seat Back Dust Boot						
	L1	1	----	----	----	----	2410 047
	D1, D2	1	----	----	----	----	2410 006
	A3-L	1	----	----	----	----	2270 929

★ Indicates use as required.

E Indicates parts not listed in any previous parts book.  
Right and left part numbers are on same line,  
first number is right, second number is left.

\* Indicates change or addition.

## 1963 PASSENGER CAR PARTS CATALOG

INTERIOR TRIM

CODE	REMARKS	PER CAR	SED.	SP. 4 D.	SUB.	SP. CL. CP.	CV. CP.
23-112-23	COVER, Folding Top Rear Bow to Link Joint L1	2	----	----	----	----	*2483 740
23-112-45	CURTAIN, Folding Top Back L1						
	(black)	1	----	----	----	----	2432 227
	(white)	1	----	----	----	----	2432 290
	D2-H (black)	1	----	----	----	----	2429 746
	D2-P (black)	1	----	----	----	----	2431 696
	D2-H (white)	1	----	----	----	----	2433 638
	D2-P (white)	1	----	----	----	----	2431 697
	A3						
	(blue)	1	----	----	----	----	2181 465
	(white)	1	----	----	----	----	2181 464
	(black)	1	----	----	----	----	2181 463
	BACK LIGHT						
	L1	1	----	----	----	----	2432 228
	D2	1	----	----	----	----	2429 827
	(cap fastener)	1	----	----	----	----	*6000 484
23-112-46	ZIPPER, Folding Top Rear Curtain						
	L1	1	----	----	----	----	*1920 TX8
	D2	1	----	----	----	----	*1923 TX8
	A3	1	----	----	----	----	2181 462
23-112-50	TAPE, Folding Top Back Curtain Quarter Stay Closure Hook (service by the inch) L1, D2	★	----	----	----	----	*1934 TX8
	Side Closure Loop (service by the inch)	★	----	----	----	----	*1933 TX8
23-112-70	RETAINER, Folding Top to Belt Bar L1						
	(center)	1	----	----	----	----	2448 103
	(side)	1	----	----	----	----	2448 104-5
	(rear)	1	----	----	----	----	2421 939
	A3-L						
	(inner)	2	----	----	----	----	2252 610
	D2						
	(galvanized) (center)	1	----	----	----	----	2189 748
	(galvanized) (side)	1	----	----	----	----	2189 852-3
	(center)	1	----	----	----	----	2421 694
	(side)	1	----	----	----	----	2421 944-5
	(rear)	1	----	----	----	----	2421 939
23-112-75	END, Wire-on Binding End D2, A3	1	----	----	----	----	*1158 976-7
23-112-88	CABLE, Folding Top Rear Bow Tension L1, D2	2	----	----	----	----	2166 660
	A3-L	2	----	----	----	----	2480 818
	L1 (side)	2	----	----	----	----	*2490 179
23-112-108	DECK and SIDE QUARTER, Folding Top L1						
	(white)	1	----	----	----	----	2432 229
	(black)	1	----	----	----	----	2432 230

★ Indicates use as required.

⊠ Indicates parts not listed in any previous parts book.  
Jan. 3, 1964 Supersedes Jan. 25, 1963.

Page IT-156D

Printed in U.S.A.  
Prices and specifications subject to change without notice.  
Right and left part numbers are on same line,  
first number is right, second number is left.  
\* Indicates change or addition.

CODE	REMARKS	PER CAR	SED.	SP. 4 D.	SUB.	SP. CL. CP.	CV. CP.
23-112-108 DECK and SIDE QUARTER Folding Top - Cont'd							
D2-H	(white)	1	----	----	----	----	2429 749
	(black)	1	----	----	----	----	2429 748
D2-P	(w/alabaster interior)						
	(white)	1	----	----	----	----	*2431 694
	(w/alabaster interior)						
	(black)	1	----	----	----	----	*2431 695
A3-L	(white)	1	----	----	----	----	2178 405
	(black)	1	----	----	----	----	2181 460
	(blue)	1	----	----	----	----	2181 461
23-112-112 PAD, Folding Top Side Quarter Stay							
L1		1	----	----	----	----	2432 826-7
D2-P	(black)	1	----	----	----	----	E2429 750-1
	(alabaster)	1	----	----	----	----	*2431 698-9
A3-L		1	----	----	----	----	2181 458-9
23-112-153 PANEL or COVER, Folding Top Pocket							
L1	(well lining cover)						
	(codes 871, 891)	1	----	----	----	----	2431 025
	(codes 873, 893)	1	----	----	----	----	2431 071
	(codes 875, 895)	1	----	----	----	----	2431 098
	(codes 878, 898)	1	----	----	----	----	2431 099
	(pocket panel cover)						
	(blue)	1	----	----	----	----	2432 796-7
	(tan)	1	----	----	----	----	2432 798-9
	(red)	1	----	----	----	----	2432 800-1
	(turquoise)	1	----	----	----	----	2432 802-3
	(upper, inner cover)						
	(blue)	1	----	----	----	----	2432 238-9
	(tan)	1	----	----	----	----	2432 240-1
	(red)	1	----	----	----	----	2432 242-3
	(turquoise)	1	----	----	----	----	2432 244-5
	(pocket panel) (paint as required)	1	----	----	----	----	2432 246-7
D2-H, D2-P	(panel) w/o arm rest						
	(codes 641, 651)	1	----	----	----	----	*2431 900-1
	(codes 643, 653)	1	----	----	----	----	2431 902-3
	(codes 645, 655)	1	----	----	----	----	2431 904-5
	(code 646)	1	----	----	----	----	2431 906-7
	(code 656)	1	----	----	----	----	2431 936-7
	(codes 648, 658)	1	----	----	----	----	2431 908-9
	(panel and reinforcement)						
	(paint as required) (use w/pad code 23-112-160)	1	----	----	----	----	E2432 470-1
	(cover)						
	(codes 641, 651)	1	----	----	----	----	2431 890-1
	(codes 643, 653)	1	----	----	----	----	2431 892-3
	(codes 645, 655)	1	----	----	----	----	2431 894-5
	(code 646)	1	----	----	----	----	2431 896-7
	(code 656)	1	----	----	----	----	2431 934-5
	(codes 648, 658)	1	----	----	----	----	2431 898-9
	(well lining panel cover)						
	(codes 641, 651)	1	----	----	----	----	2431 425
	(codes 643, 653)	1	----	----	----	----	2431 426
	(codes 645, 655)	1	----	----	----	----	2431 427

★ Indicates use as required.

☒ Indicates parts not listed in any previous parts book. Right and left part numbers are on same line, first number is right, second number is left.

\* Indicates change or addition.

# 1963 PASSENGER CAR PARTS CATALOG

INTERIOR TRIM

CODE	REMARKS	PER CAR	SED.	SP. 4 D.	SUB.	SP. CL. CP.	CV. CP.	
112-153	PANEL or COVER, Folding Top Pocket - Cont'd							
	D2H, D2P (well lining cover) (codes 646, 656)	1	----	----	----	----	2431 428	
	(codes 648, 658) (well cover to quarter belt bar retainer screw)	1	----	----	----	----	2431 429	
		2	----	----	----	----	6023 381	
A3-L (shelf panel)	(code 671)	1	----	----	----	----	2137 726-7	
	(code 672)	1	----	----	----	----	2137 728-9	
	(code 673)	1	----	----	----	----	2137 730-1	
	(code 675)	1	----	----	----	----	2137 732-3	
	(code 678)	1	----	----	----	----	2137 734-5	
(cover)	(code 671)	1	----	----	----	----	2137 756-7	
	(code 672)	1	----	----	----	----	2137 758-9	
	(code 673)	1	----	----	----	----	2137 760-1	
	(code 675)	1	----	----	----	----	2137 762-3	
	(code 678)	1	----	----	----	----	2137 764-5	
(rear quarter top pocket panel)	(code 671)	1	----	----	----	----	2137 746-7	
	(code 672)	1	----	----	----	----	2137 748-9	
	(code 673)	1	----	----	----	----	2137 750-1	
	(code 675)	1	----	----	----	----	2137 752-3	
	(code 678)	1	----	----	----	----	2137 754-5	
WELL, Folding Top A3-L	(code 671)	1	----	----	----	----	E2181 466	
	(code 672)	1	----	----	----	----	E2181 467	
	(code 673)	1	----	----	----	----	E2181 468	
	(code 675)	1	----	----	----	----	E2181 469	
	(code 678)	1	----	----	----	----	E2181 470	
112-160 PAD, Folding Top Pocket Panel Arm Rest	L1	(codes 871, 891) (blue)	1	----	----	----	E2432 804-5	
		(codes 873, 893) (tan)	1	----	----	----	E2432 806-7	
		(codes 875, 895) (red)	1	----	----	----	E2432 808-9	
		(codes 878, 898) (turquoise)	1	----	----	----	E2432 810-1	
	D2	(codes 641, 651)	1	----	----	----	----	*2432 874-5
		(codes 643, 653)	1	----	----	----	----	*2432 876-7
		(codes 645, 655)	1	----	----	----	----	*2432 878-9
		(code 646)	1	----	----	----	----	*2432 880-1
		(code 658)	1	----	----	----	----	*2432 882-3
		(code 656)	1	----	----	----	----	E2432 884-5
	113-2 WEATHERCORD, Door A3 (sold by the inch)	(code 561) (blue)	★	*2182 165	*2182 165	*2182 165	*2182 165	*2182 165
		(codes 571, 671) (blue)	★	E2182 174	E2182 174	E2182 174	E2182 174	E2182 174
(code 572) (green)		★	E2182 175	E2182 175	E2182 175	E2182 175	E2182 175	
(code 563) (tan)		★	*2182 167	*2182 167	*2182 167	*2182 167	*2182 167	
(codes 573, 673) (tan)		★	E2182 176	E2182 176	E2182 176	E2182 176	E2182 176	
(codes 565, 575, 675) (red)		★	E2182 172	E2182 172	E2182 172	E2182 172	E2182 172	
(code 568) (turquoise)		★	*2182 169	*2182 169	*2182 169	*2182 169	*2182 169	
(codes 578, 678) (turquoise)		★	E2182 173	E2182 173	E2182 173	E2182 173	E2182 173	
(black)		★	*2182 164	*2182 164	*2182 164	*2182 164	*2182 164	

dates use as required.  
 dates parts not listed in any previous parts book.  
 3, 1964 Supersedes Dec. 14, 1962.

Printed in U.S.A.  
 Prices and specifications subject to change without notice.  
 Right and left part numbers are on same line,  
 first number is right, second number is left.

\* Indicates change or addition.

CODE	REMARKS	PER CAR	SED.	SP. 4 D.	SUB.	SP. CL. CP.	CV. CP.
23-113-45	WEATHERCORD, Quarter Window Opening L1 (2 D.) (codes 801, 831) (codes 803, 833) (codes 805, 835) (codes 808, 838)	1 1 1 1	E2432 944 E2432 930 *1515 TR6 2432 942				
	D1, D2 (2 D.) (codes 501, 521) (blue) (codes 503, 523) (tan) (codes 505, 525) (red) (codes 508, 528) (turquoise) (code 526) (alabaster) (code 694) (gray)	1 1 1 1 1 1	E2432 944 E2432 930-1 *1515 TR6 *2432 942-3 2413 404-5 2413 366				
23-113-50	WELT, Windshield Garnish Moulding to Instrument Panel Pad D1, D2, A3 (paint as required)	2	1758 241	1758 241	1758 241	1758 241	1758 241
23-113-52	STRIP, Windshield Weatherstrip Lower Inside Trim L1 (blue) (tan) (turquoise)	1 1 1	---- ---- ----	---- ---- ----	---- ---- ----	2432 716 2432 717 2432 719	2432 716 2432 717 2432 719
23-113-56	WEATHERCORD, Folding Top Header L1 (white) (black)	1 1	---- ----	---- ----	---- ----	---- ----	2432 958 2432 959
23-113-84	WELT, Folding Top Header L1 (black) D2-P (alabaster) (codes 651, 653, 655, 656, 658) A3-L (codes 671, 672, 673, 675, 678) (black)	1 1 1 2	---- ---- ---- ----	---- ---- ---- ----	---- ---- ---- ----	---- ---- ---- ----	2432 150 2432 151 2179 386
23-114-2	MATERIAL, Body Cloth Trim L1-L (63" wide) (code 801) (blue) (code 803) (tan) (code 805) (red) (code 808) (turquoise)	★ ★ ★ ★	2185 890 2185 891 2185 892 2185 893				
	D1-L, D2-L (54" wide) (code 501) (blue) (code 503) (tan) (code 505) (red) (code 508) (turquoise)	★ ★ ★ ★	2185 870 2185 871 2185 872 2185 873				
	D1-M, D2-M (54" wide) (code 521) (blue) (code 523) (tan) (code 525) (red) (code 526) (alabaster) (code 528) (turquoise)	★ ★ ★ ★ ★	2185 874 2185 875 2185 876 2185 877 2185 878	2185 874 2185 875 2185 876 2185 877 2185 878	---- ---- ---- ---- ----	2185 874 2185 875 2185 876 2185 877 2185 878	2185 874 2185 875 2185 876 2185 877 2185 878
	D1-H (4 D.) (50" wide) (code 541) (blue) (code 543) (tan) (code 545) (red) (code 546) (alabaster) (code 548) (turquoise)	★ ★ ★ ★ ★	2185 879 2185 880 2185 881 2185 882 2185 883				

★ Indicates use as required.

E Indicates parts not listed in any previous parts book.  
Right and left part numbers are on same line,  
first number is right, second number is left.

\* Indicates change or addition.

## 1963 PASSENGER CAR PARTS CATALOG

INTERIOR TRIM

CODE	REMARKS	PER CAR	SED.	SP. 4 D.	SUB.	SP. CL. CP.	CV. CP.
23-114-2	MATERIAL, Body Cloth Trim - Cont'd						
	A3 (63" wide)						
	(code 571)	1	2186 224	----	----	2186 224	
	(code 572)	1	2186 225	----	----	2186 225	
	(code 573)	1	2186 226	----	----	2186 226	
	(code 575)	1	2186 227	----	----	2186 227	
	(code 578)	1	2186 228	----	----	2186 228	
	A3-E (62" wide)						
	(code 561)	1	2186 264	----	2186 264		
	(code 563)	1	2186 265	----	2186 265		
	(code 565)	1	2186 266	----	2186 266		
	(code 568)	1	2186 267	----	2186 267		
23-114-10	BINDING, 5/8" Wire, Black						
	D2	1	----	----	----	----	E2181 851
	D2, A3 (white)	1	----	----	----	----	*2177 529
23-114-15	MATERIAL, Leather (Imitation)						
	L1 (white)						
	(for padded sun visors)	★	*2185 329	*2185 329	*2185 329	*2185 329	*2185 329
	L1-L						
	(codes 801, 851, 871)						
	(34-DA-22) (54") (1601 blue)	★	*2185 666	----	*2185 666	----	*2185 666
	(34-DA-22) (54") (1602 blue)	★	2185 681	----	2185 681		
	(32-CH-22) (54") (1602 Blue)	★	2185 680	----	2185 680		
	(32-CH-22) (54") (1600 blue)						
	(code 871) (4 D.)	★	2185 663				
	(26-DS-75) (43.5") (1601-1 blue)						
	(code 851)	★	----	----	2185 820		
	(19-C-22) (54") (1602 blue)						
	(codes 801, 851, 871) (4 D.)	★	2185 625	----	2185 625		
	(codes 803, 853)						
	(34-DA-22) (54") (1608 tan)	★	2185 683	----	2185 683		
	(34-DA-22) (54") (1607 tan)						
	(codes 833, 873) (4 D.)	★	2185 673				
	(32-CH-22) (54") (1608 tan)						
	(codes 803, 853)	★	2185 682	----	2185 682		
	(32-CH-22) (54") (1606 tan)						
	(code 873) (4 D.)	★	2185 742				
	(19-C-22) (54") (1608 tan)						
	(codes 803, 853, 873) (4 D.)	★	2185 627				
	(34-DA-22) (54") (1621 red)						
	(codes 805, 855, 875)	★	2185 668	----	2185 668		
	(32-CH-22) (54") (1621 red)						
	(codes 805, 855, 875)	★	2185 665	----	2185 665		
	(26-DS-75) (43.5") (1621 red)						
	(code 855)	★	----	----	2185 822		
	(19-C-22) (54") (1621 red)						
	(codes 805, 855, 875) (4 D.)	★	2185 723	----	2185 723		
	(codes 808, 858)						
	(34-DA-22) (54")						
	(1620 turquoise)	★	2185 710	----	2185 710		
	(32-CH-22) (54")						
	(1620 turquoise)	★	2185 709	----	2185 709		
	(19-C-22) (54")						
	(1620 turquoise)	★	----	----	2185 749		
	(code 858)						
	(26-DS-75) (43.5")						
	(1619-1 turquoise)	★	----	----	2185 823		
	(codes 808, 858)						
	(34-DA-22) (54")						
	(1620 turquoise)	★	2185 710	----	2185 710		

★ Indicates use as required.

☐ Indicates parts not listed in any previous parts book.  
Jan. 3, 1964 Supersedes Dec. 14, 1962.

Page IT-156H

Printed in U.S.A.  
Prices and specifications subject to change without notice.  
Right and left part numbers are on same line,  
first number is right, second number is left.

\* Indicates change or addition.



CODE	REMARKS	PER CAR	SED.	SP. 4 D.	SUB.	SP. CL. CP.	CV. CP.
23-114-15	MATERIAL, Leather (Imitation)-Cont'd						
	L1-L						
	(codes 838, 878)						
	(34-DA-22) (54")						
	(1619 turquoise)	★	2185 675	----	2185 675	----	2185 675
	(codes 808, 858)						
	(32-CH-22) (54")						
	(1620 turquoise)	★	2185 709	----	2185 709	----	2185 709
	(code 898)						
	(32-CH-22) (54")						
	(1619 turquoise)	★	2185 674	----		----	
	(codes 838, 878)						
	(32-CH-22) (54")						
	(1618 turquoise)	★	2186 087	----	2186 087	----	2186 087
	L1-H						
	(34-DA-22) (54") (1601 red)						
	(codes 831, 871)	★	2185 666	----	2185 666	----	2185 666
	(32-CH-22) (54") (1600 blue)						
	(codes 831, 871)	★	2185 663	----	2185 663	----	2185 663
	(32-CH-22) (54") (1601 blue)	★	2185 660	----	2185 660	----	
	(19-C-22) (54") (1602 blue)						
	(codes 831, 871)	★	2185 625	----	2185 625	----	
	(34-DA-22) (54") (1607 tan)						
	(codes 833, 873)	★	2185 673	----	2185 673	----	2185 673
	(32-CH-22) (54") (1606 tan)						
	(codes 833, 873)	★	2185 742	----	2185 742	----	2185 742
	(34-DA-22) (54") (1607 tan)						
	(codes 833, 873)	★	2185 673	----	2185 673	----	2185 673
	(19-C-22) (54") (1608 tan)						
	(codes 833, 873)	★	2185 627	----	2185 627	----	2185 627
	(codes 835, 875)						
	(34-DA-22) (54") (1621 red)	★	2185 668	----	2185 668	----	2185 668
	(32-CH-22) (54") (1621 red)	★	2185 665	----	2185 665	----	2185 665
	(19-C-22) (54") (1621 red)	★	2185 723	----	2185 723	----	2185 723
	(codes 838, 878)						
	(34-DA-22) (54")						
	(1619 turquoise)	★	2185 675	----	2185 675	----	2185 675
	(32-CH-22) (54")						
	(1618 turquoise)	★	2186 087	----	2186 087	----	2186 087
	(19-C-22) (54")						
	(1620 turquoise)	★	2185 749	----	2185 749	----	2185 749
	L1-P						
	(code 891)						
	(19-C-22) (54") (1601 blue)	★	----	----	----	2185 620	
	(code 893)						
	(19-C-22) (54") (1607 tan)	★	----	----	----	2185 622	
	(code 895)						
	(32-CH-22) (54") (1621 red)	★	----	----	----	2185 665	
	(19-C-22) (54") (1621 red)	★	----	----	----	2185 723	
	(code 898)						
	(32-CH-22) (54")						
	(1619 turquoise)	★	----	----	----	2185 674	
	(19-C-22) (54")						
	(1619 turquoise)	★	----	----	----	2185 724	
	D1, D2						
	(codes 501, 521, 541, 601, 611, 621, 641, 651)						
	(32-DD-74) (58") (1601 blue)	★	2185 744	----	2185 744		
	(31-DU-80) (55") (1601-1 blue)	★	----	----	2186 013		
	(28-AM-22) (50") (1601 blue)	★	2185 615	2185 615	2185 615	2185 615	2185 615
	(28A-AM-22)(50")(1600 blue)	★	2185 778	----	2185 778		

★ Indicates use as required.

☐ Indicates parts not listed in any previous parts book.  
Right and left part numbers are on same line,  
first number is right, second number is left.

\* Indicates change or addition.

Printed in U.S.A.

Prices and specifications subject to change without notice.

## 1963 PASSENGER CAR PARTS CATALOG

INTERIOR TRIM

CODE	REMARKS	PER CAR	SED.	SP. 4 D.	SUB.	SP. CL. CP.	CV. CP.
23-114-15	MATERIAL, Leather (Imitation) -Cont'd D1, D2						
	(20-DT-77) (56") (1600 blue)	★	2185 855				
	(19-BC-22) (54") (1600 blue)	★	2185 736	2185 736	2185 736	2185 736	2185 736
	(19-C-22) (54") (1602 blue)	★	2185 625	-----	2185 625		
	(19-C-22) (54") (1601 blue)	★	2185 620	2185 620	-----	2185 620	2185 620
	(19-DJ-22) (54") (1601 blue)	★	2185 798	2185 798	2185 798	2185 798	
	(codes 503, 523, 543, 603, 613, 623, 643, 653)						
	(32-DD-74) (58") (1607 tan)	★	2185 745	-----	2185 745		
	(31-DU-80) (55") (1607 tan)	★	-----	-----	2186 014		
	(28-AM-22) (50") (1607 tan)	★	2185 617	2185 617	2185 617	2185 617	2185 617
	(28A-AM-22) (50") (1606 tan)	★	2185 779	-----	2185 779		
	(20-DT-77) (56") (1607 tan)	★	2185 856				
	(codes 508, 528, 548, 608, 628, 648)						
	(32-DD-74) (54") (1619 turquoise)	★	-----	-----	2185 747		
	(31-DU-80) (55") (1619 turquoise)	★	-----	-----	2186 016		
	(28-AM-22) (50") (1618 turquoise)	★	2186 132	*2185 722	2186 132	*2185 722	*2185 722
	(20-DT-77) (56") (1619 turquoise)	★	2185 859				
	(19-C-22) (54") (1619 turquoise)	★	2185 724	2185 724	-----	2185 724	2185 724
	(19B-C-22) (54") (1620 turquoise)	★	2185 749				
	(19-DJ-22) (54") (1619 turquoise)	★	2185 815	2185 815	2185 815	2185 815	
	(19-C-22) (54") (1620 turquoise)	★	-----	-----	2185 749		
	(19-C-22) (code 526) (54") (black)	★	-----	-----	-----	-----	2185 632
	(19-C-22) (54") (1607 tan)	★	2185 622	2185 622	2185 622	2185 622	2185 622
	(19-DJ-22) (54") (1607 tan)	★	2185 800	2185 800	2185 800	2185 800	
	(19-BC-22) (54") (1606 tan)	★	2185 738	2185 738	-----	2185 738	2185 738
	(19-C-22) (54") (1608 tan)	★	2185 627	-----	2185 627		
	(codes 505, 525, 545, 605, 625, 645, 655)						
	(32-DD-74) (58") (1621 red)	★	-----	-----	2185 746		
	(31-DU-80) (55") (1621 red)	★	-----	-----	2186 015		
	(20-DT-77) (56") (1621 red)	★	2185 857				
	(19C-C-22) (54") (1621 red)	★	2185 723	2185 723	2185 723	2185 723	2185 723
	(19-DJ-22) (54") (1621 red)	★	2185 801	2185 801	2185 801	2185 801	2185 801
	(codes 526, 546, 621, 623, 625, 626, 628, 641, 643, 645, 646, 648)						
	(32-DD-74) (58") (1617 alabaster)	★	-----	-----	2185 833		
	28A-AM-22) (50") (1617) alabaster)	★	*2185 630	*2185 630	*2185 630	*2185 630	*2185 630
	(20-DT-77) (56") (1617 alabaster)	★	2185 858				
	(19-C-22) (54") (1617 alabaster)	★	2185 631	2185 631	2185 631	2185 631	2185 631
	(19-DJ-22) (54") (1617 alabaster)	★	2185 802	2185 802	2185 802	2185 802	2185 802

★ Indicates use as required.

E Indicates parts not listed in any previous parts book.  
Jan. 3, 1964 Supersedes Dec. 14, 1962.

Page IT-156J

Printed in U.S.A.  
Prices and specifications subject to change without notice.  
Right and left part numbers are on same line,  
first number is right, second number is left.

\* Indicates change or addition.

CODE	REMARKS	PER CAR	SED.	SP. 4 D.	SUB.	SP. CL. CP.	CV. CP.
23-114-15	MATERIAL, Leather (Imitation)-Cont'd D2-P (code 651) (19A-C-22) (54") (1601 blue) (19B-C-22) (54") (1602 blue) (code 653) (19A-C-22) (54") (1607 tan) (19B-C-22) (54") (1608 tan) (code 655) (19A-C-22) (54") (1621 red)	★	----	----	----	----	2185 620
		★	----	----	----	2185 625	2185 625
		★	----	----	----	----	2185 622
		★	----	----	----	2185 627	2185 627
		★	----	----	----	2185 723	2185 723
	(code 658) (28-AM-22) (50") (1619 turquoise)	★	----	----	----	2185 722	2185 722
	(19-AC-22) (54") (1619 turquoise)	★	----	----	----	----	2185 724
	(19B-C-22) (54") (1620 turquoise)	★	----	----	----	2185 749	2185 749
	(codes 651, 653, 655, 658) (19-C-22) (54") (1617 alabaster)	★	----	----	----	2185 631	2185 631
	(19-DJ-22) (54") (1617 alabaster)	★	----	----	----	2185 802	2185 802
	(19B-C-22) (54") (1624 black)	★	----	----	----	2185 632	2185 632
A3-E	(codes 561, 563, 565, 568) (19-AC-22) (54") (1624 black) (code 584) (28A-AM-22)(50")(1610 gray)	★	2185 632	----	2185 632		
		★	2185 633				
A3-L	(codes 571, 671) (19-C-22) (54") (1600 blue) (28A-AM-22)(50")(1602 blue) (codes 572, 672) (19-C-22) (54") (1603 green) (codes 575, 675) (28A-AM-22)(50")(1619 red) (codes 584, 684) (19-C-22) (54") (1609 gray) (codes 671, 672, 673, 675, 678) (19C-C-22)(54") (1624 black)	★	2185 736	2185 736	2185 736	2185 736	2185 736
		★	2185 647	2185 647	2185 647	2185 647	2185 647
		★	2185 737	2185 737	2185 737	2185 737	2185 737
		★	2186 242	2186 242	2186 242	2186 242	2186 242
		★	2185 740				
		★	----	----	2185 632		
23-115-4	PUSH NUT, Front Seat Back to Cushion Mounting D2-P (1/2") (3/8") 3rd. Seat Hinge Support Stud	4 4 2	----	----	----	*2410 102 *2160 648	*2410 102 *2160 648
23-115-5	WASHER, Front Seat Center Arm Rest Trim D2-H	2	1918 299	1918 299	1918 299	1918 299	1918 299
23-115-6	PIN, Seat Back Frame to Cushion Mounting L1, D2-P  FASTENER, Deck Opening Upper Panel Belt L1, D2	4  8	----	----	----	2410 054  ----	2410 054  2094 394

★ Indicates use as required.  
 □ Indicates parts not listed in any previous parts book.  
 Right and left part numbers are on same line,  
 first number is right, second number is left.  
 \* Indicates change or addition.

Printed in U.S.A.  
 Prices and specifications subject to change without notice.  
 January 3, 1964.

