

1963 CHRYSLER 1963 IMPERIAL

INTERIOR TRIM

HOW TO USE INTERIOR TRIM ILLUSTRATIONS

The illustrations in this section are actual and each body style showing the Interior Trim is included.

The letters shown on the illustration indicate the description of the part and the part type code when referred to the legend which appears preceding the listing of the parts. The letters are consistent throughout the illustrations as "A" is always a Door Trim Panel, Code 23-92-5.

The numbers on the illustration indicate the distribution of material and type of material used. The numbers may vary with each illustration. The legend appears on the illustration.

For complete information on "How to Order" Trim Parts, see Mopar Parts Price List.

C
H
R
Y
S
L
E
R

I
M
P
E
R
I
A
L

1963 CHRYSLER - T SERIES

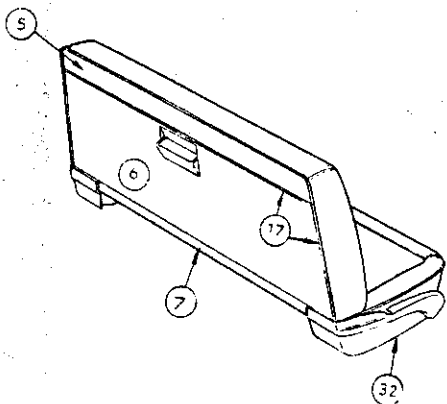
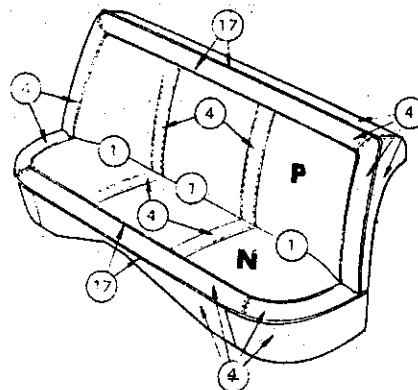
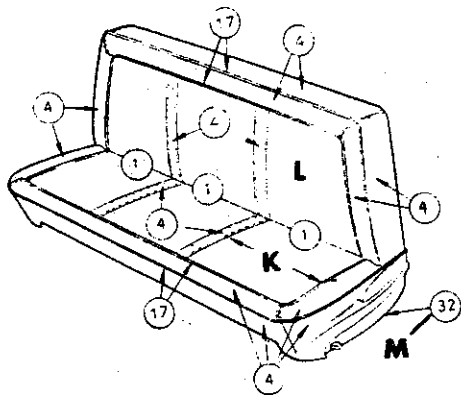
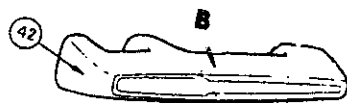
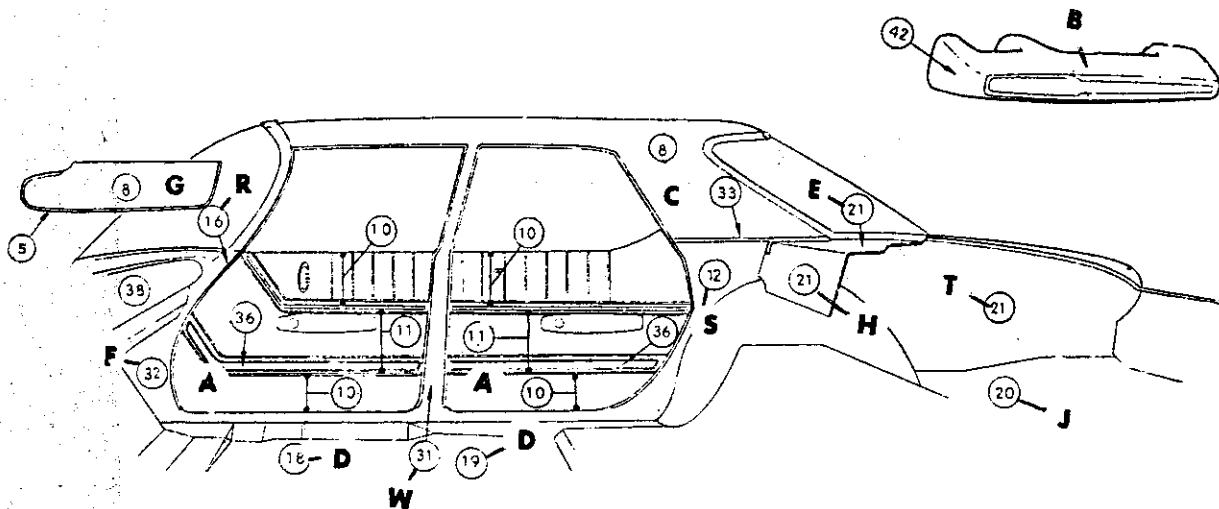

DISTRIBUTION OF MATERIAL

- 1 BODY CLOTH 1
- 4 IMITATION LEATHER 28-AM-22
- 5 IMITATION LEATHER 19-C-22
- 6 IMITATION LEATHER 19A-C-22
- 7 IMITATION LEATHER 28A-AM-22
- 8 IMITATION LEATHER 15, 5-C-81
- 10 IMITATION LEATHER 19-DJ-22
- 11 IMITATION LEATHER 19A-DJ-22
- 12 IMITATION LEATHER 19C-C-22
- 16 LACE
- 17 EXTRUDED VINYL
- 18 FLOOR COVERING-FRONT-CARPET
- 19 FLOOR COVERING-REAR-CARPET
- 20 FLOOR COVERING-LUGG. COMPT. RUBBER
- 21 EMBOSSED CARDBOARD
- 30 PLASTIC
- 31 PAINT
- 32 METAL
- 33 MOULDING
- 34 SHEETING
- 35 POLYETHYLENE
- 36 MYLAR
- 38 MOULDED RESIN
- 42 PLASTISOL

Distribution Drawing Legend Page Appears Following Illustration Section

Codes 101, 102, 103, 105, 108

TCL-411

1963 CHRYSLER TC1-L 4 DOOR SEDAN
CLOTH & IMITATION LEATHER TRIM

1963 CHRYSLER - T SERIES

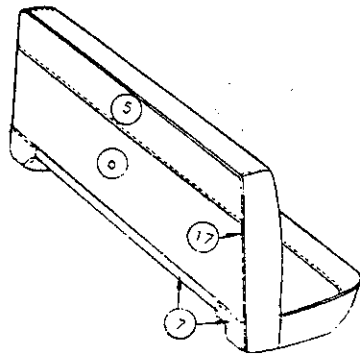
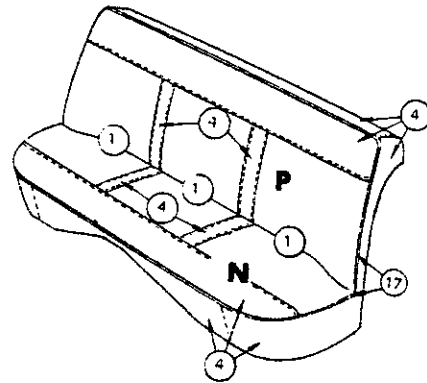
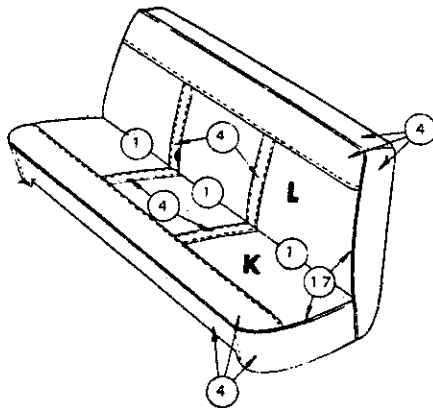
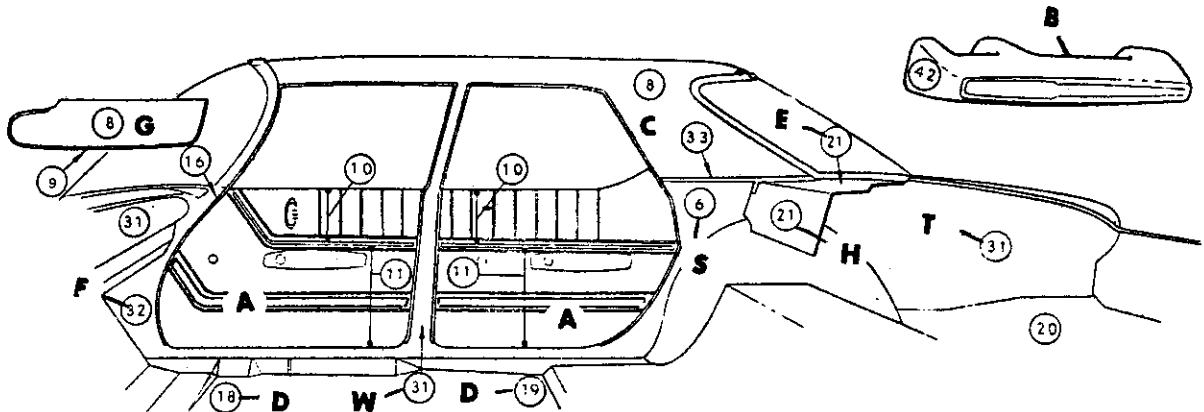

DISTRIBUTION OF MATERIAL

- 1 BODY CLOTH
- 4 IMITATION LEATHER
- 5 IMITATION LEATHER
- 6 IMITATION LEATHER
- 7 IMITATION LEATHER
- 8 IMITATION LEATHER
- 10 IMITATION LEATHER
- 11 IMITATION LEATHER
- 16 LACE
- 17 EXTRUDED VINYL
- 18 FLOOR COVERING-FRONT-RUBBER
- 19 FLOOR COVERING-REAR-RUBBER
- 20 FLOOR COVERING-LUGG. COMPT. RUBBER
- 21 EMBOSSED CARDBOARD
- 30 PLASTIC
- 31 PAINT
- 32 METAL
- 36 MYLAR
- 38 MOULDED RESIN
- 42 PLASTISOL
- 28-AM-22
- 19-C-22
- 19A-C-22
- 28A-AM-22
- 15, 5-C-81
- 19-DJ-22
- 19A-DJ-22

Distribution Drawing Legend Page Appears Following Illustration Section

Code 104

TCL-411A

1963 CHRYSLER TC1-L 4 DOOR SEDAN
CLOTH & IMITATION LEATHER TRIM

1963 CHRYSLER - T SERIES

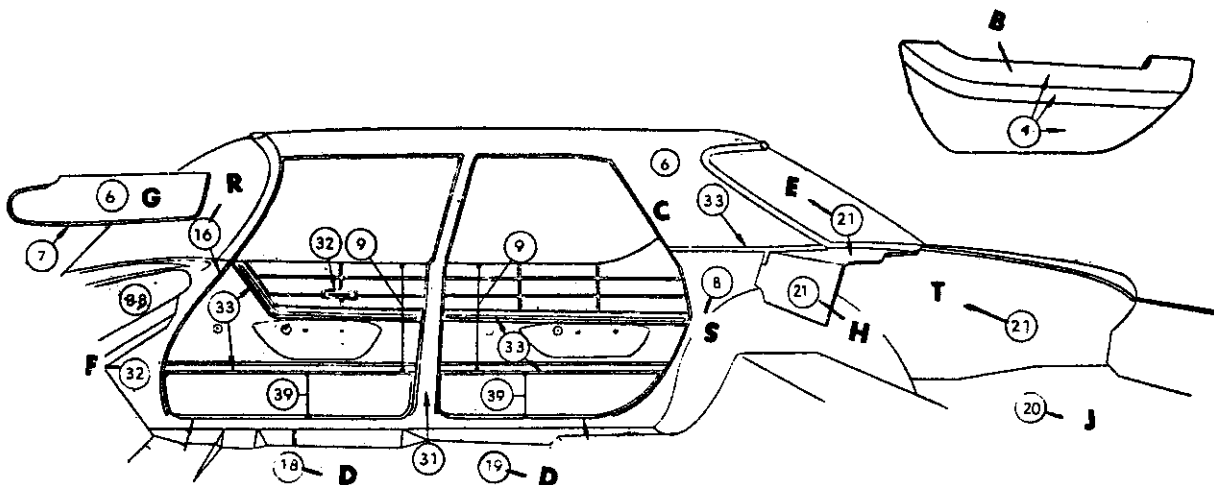

VULC & STITCHED DESIGN

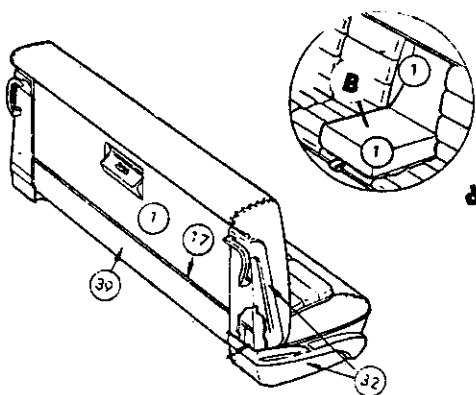
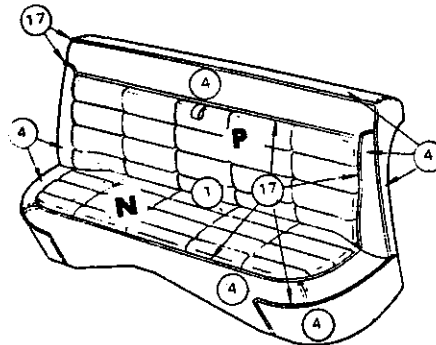
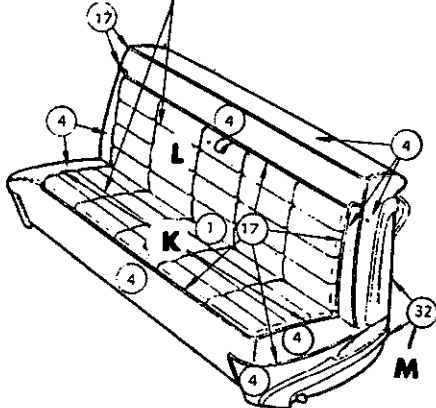

DISTRIBUTION OF MATERIAL

- 1 BODY CLOTH 1
- 4 IMITATION LEATHER 28-AM-22
- 5 IMITATION LEATHER 19-C-22
- 6 IMITATION LEATHER 15, 5-C-81
- 8 IMITATION LEATHER 19B-C-22
- 9 IMITATION LEATHER 19-DJ-22
- 16 LACE
- 17 EXTRUDED VINYL
- 18 FLOOR COVERING-FRONT-CARPET
- 19 FLOOR COVERING-REAR-CARPET
- 20 FLOOR COVERING-LUGG. COMPT. CARPET
- 21 EMBOSSED CARDBOARD
- 30 PLASTIC
- 31 PAINT
- 32 METAL
- 33 MOULDING
- 35 POLYETHYLENE
- 36 MYLAR
- 38 MOULDED RESIN
- 39 CARPET

Distribution Drawing Legend Page Appears Following Illustration Section

Codes 141, 142, 143, 144, 148

TCH-411

1963 CHRYSLER TC3-H 4 DOOR SEDAN
CLOTH & IMITATION LEATHER TRIM

1963 CHRYSLER - T SERIES

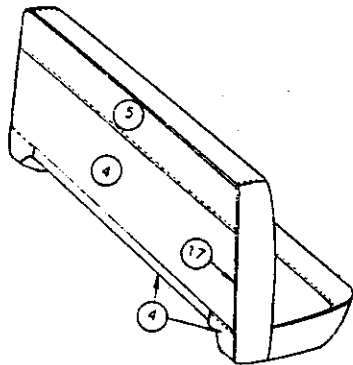
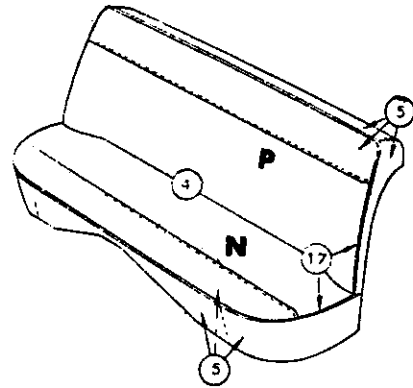
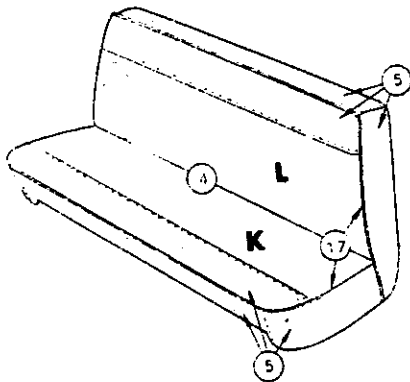
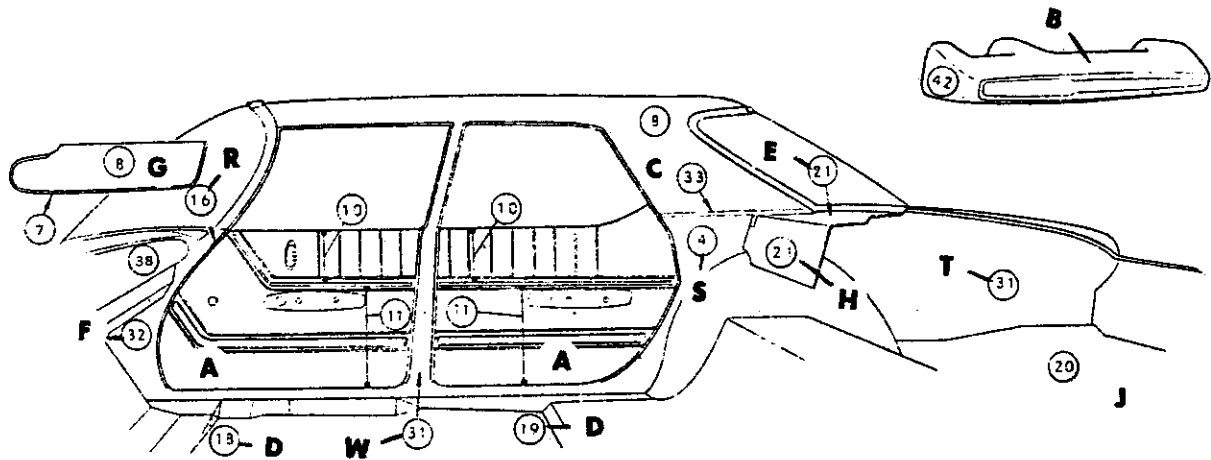

DISTRIBUTION OF MATERIAL

- 4 IMITATION LEATHER 37-CX-22
- 5 IMITATION LEATHER 37A-CX-22
- 7 IMITATION LEATHER 19-C-22
- 8 IMITATION LEATHER 15, 5-C-81
- 10 IMITATION LEATHER 19-DJ-22
- 11 IMITATION LEATHER 19A-DJ-22
- 16 LACE
- 17 EXTRUDED VINYL
- 18 FLOOR COVERING-FRONT-RUBBER
- 19 FLOOR COVERING-REAR-RUBBER
- 20 FLOOR COVERING-LUGG, COMPT, RUBBER
- 21 EMBOSSED CARDBOARD
- 30 PLASTIC
- 31 PAINT
- 32 METAL
- 33 MOULDING
- 36 MYLAR
- 38 MOULDED RESIN
- 42 PLASTISOL

Distribution Drawing Legend Page Appears Following Illustration Section

Code 204

TCL-414

1963 CHRYSLER TC1-L 4 DOOR SEDAN
IMITATION LEATHER TRIM

1963 CHRYSLER - T SERIES

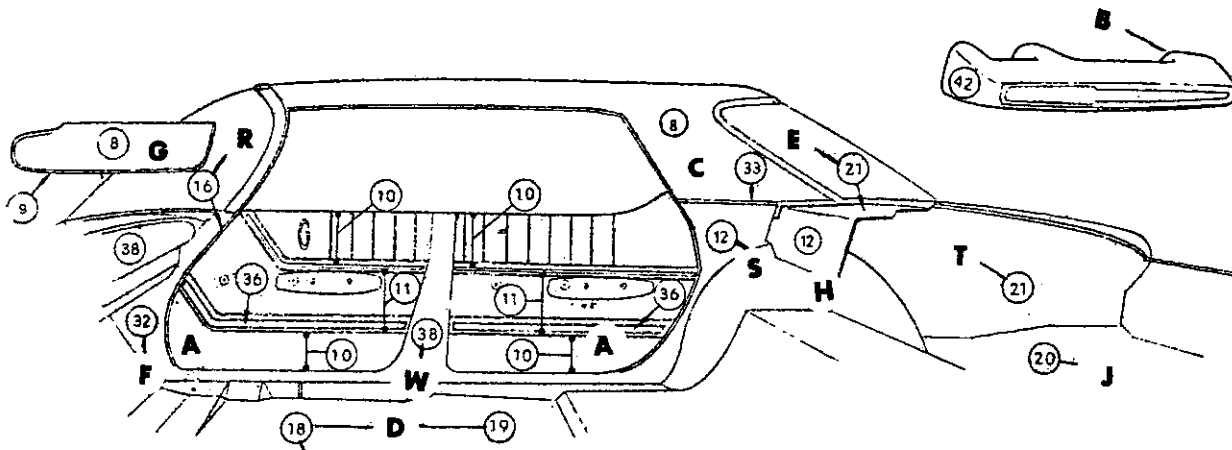

STITCHED DESIGN
(FALES)

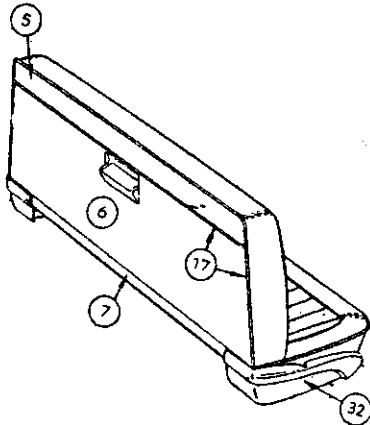
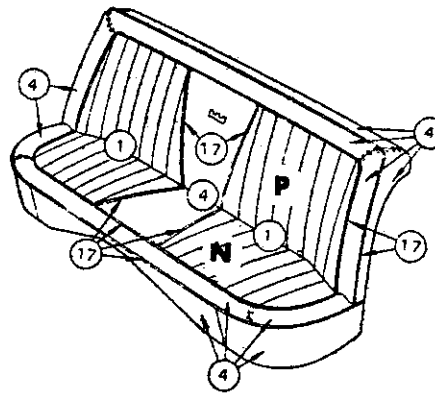
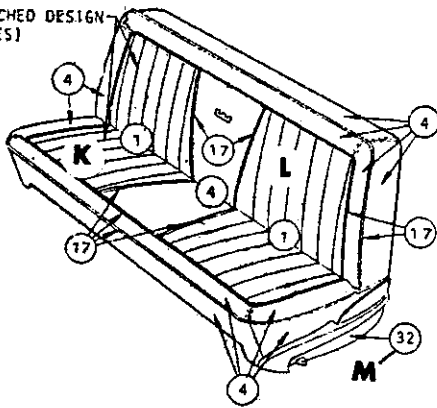

DISTRIBUTION OF MATERIAL

- 1 BODY CLOTH 1
- 4 IMITATION LEATHER 28-AM-22
- 5 IMITATION LEATHER 19-C-22
- 6 IMITATION LEATHER 19A-C-22
- 7 IMITATION LEATHER 28A-AM-22
- 8 IMITATION LEATHER 15, 5-C-81
- 10 IMITATION LEATHER 19-DJ-22
- 11 IMITATION LEATHER 19A-DJ-22
- 12 IMITATION LEATHER 19C-C-22
- 16 LACE
- 17 EXTRUDED VINYL
- 18 FLOOR COVERING-FRONT-CARPET
- 19 FLOOR COVERING-REAR-CARPET
- 20 FLOOR COVERING-LUGG. COMPT, RUBBER
- 21 EMBOSSED CARDBOARD
- 30 PLASTIC
- 31 PAINT
- 32 METAL
- 33 MOULDING
- 35 POLYETHYLENE
- 36 MYLAR
- 38 MOULDED RESIN
- 42 PLASTISOL

Distribution Drawing Legend Page Appears Following Illustration Section

Codes 111, 112, 113, 115

TCL-431

1963 CHRYSLER TC1-L 4 DOOR HARDTOP
CLOTH & IMITATION LEATHER TRIM

1963 CHRYSLER - T SERIES

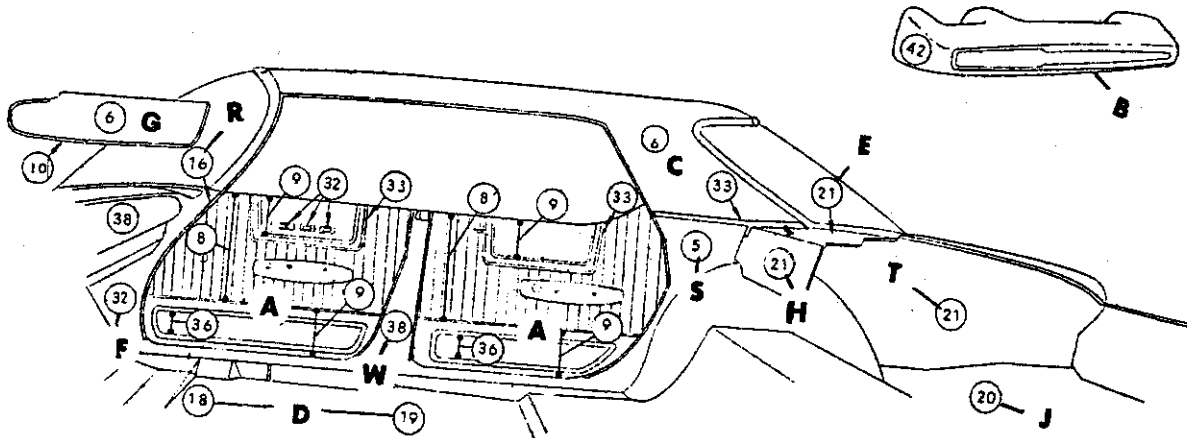

STITCHED DESIGN
(FALES)

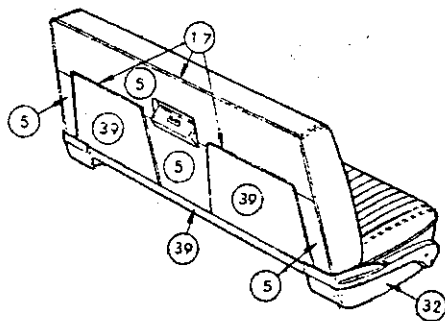
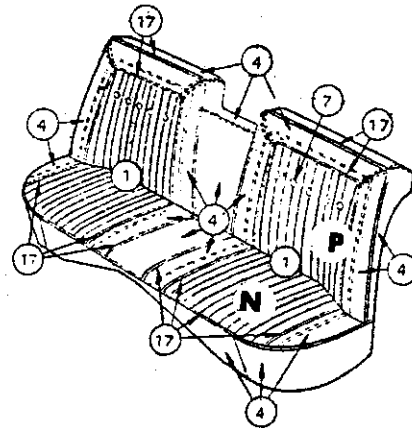
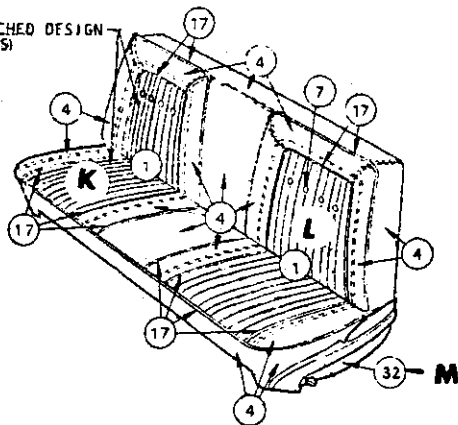

DISTRIBUTION OF MATERIAL

- 1 BODY CLOTH
- 4 IMITATION LEATHER
- 5 IMITATION LEATHER
- 6 IMITATION LEATHER
- 7 IMITATION LEATHER
- 8 IMITATION LEATHER
- 9 IMITATION LEATHER
- 16 LACE
- 17 EXTRUDED VINYL
- 18 FLOOR COVERING-FRONT-CARPET
- 19 FLOOR COVERING-REAR-CARPET
- 20 FLOOR COVERING-LUGG. COMPT. RUBBER
- 21 EMBOSSED CARDBOARD
- 30 PLASTIC
- 31 PAINT
- 32 METAL
- 33 MOULDING
- 35 POLYETHYLENE
- 36 MYLAR
- 38 MOULDED RESIN
- 39 CARPET
- 42 PLASTISOL
- 28-AM-22
- 19-C-22
- 15, 5-C-B1
- 19A-C-22
- 19-DJ-22
- 19A-DJ-22

Distribution Drawing Legend Page Appears Following Illustration Section

Codes 121, 123, 125, 126

TCM-431

1963 CHRYSLER TC2-M 4 DOOR HARDTOP
CLOTH & IMITATION LEATHER TRIM

1963 CHRYSLER - T SERIES

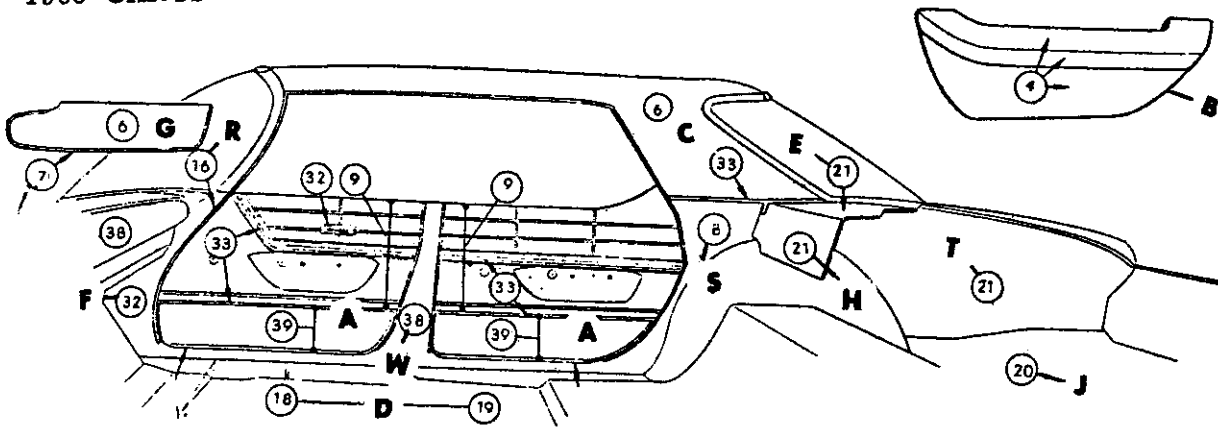

VULC. & STITCHED DESIGN

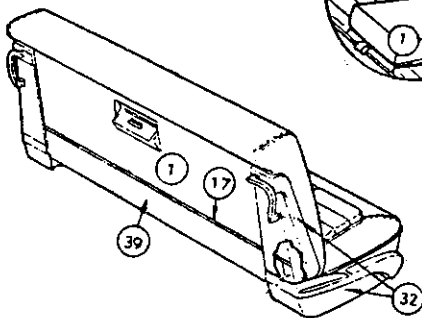
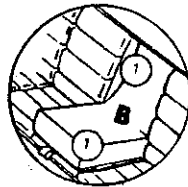
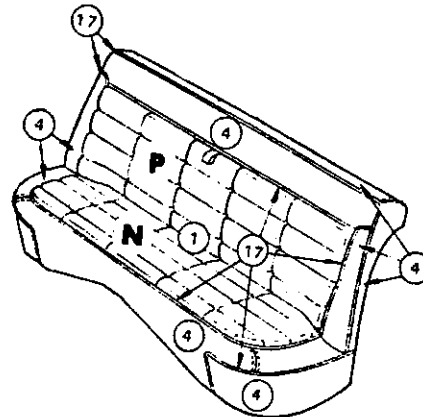
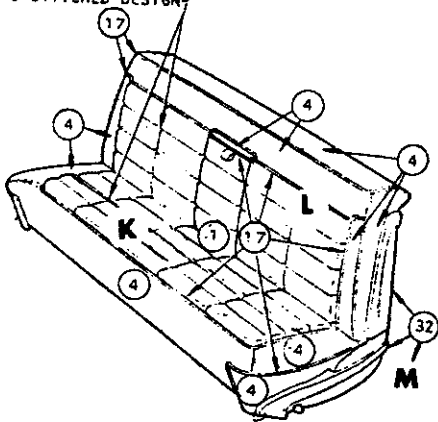

DISTRIBUTION OF MATERIAL

- 1 BODY CLOTH
- 4 IMITATION LEATHER
- 5 IMITATION LEATHER
- 6 IMITATION LEATHER
- 8 IMITATION LEATHER
- 9 IMITATION LEATHER
- 16 LACE
- 17 EXTRUDED VINYL
- 18 FLOOR COVERING-FRONT-CARPET
- 19 FLOOR COVERING-REAR-CARPET
- 20 FLOOR COVERING-LUGG. COMPT. CARPET
- 21 EMBOSSSED CARDBOARD
- 30 PLASTIC
- 31 PAINT
- 32 METAL
- 33 MOULDING
- 35 POLYETHYLENE
- 36 MYLAR
- 38 MOULDED RESIN
- 39 CARPET

Distribution Drawing Legend Page Appears Following Illustration Section

Codes 141, 142, 143, 144, 148

TCH-431

1963 CHRYSLER TC3-H 4 DOOR HARDTOP
CLOTH & IMITATION LEATHER TRIM

1963 CHRYSLER - T SERIES

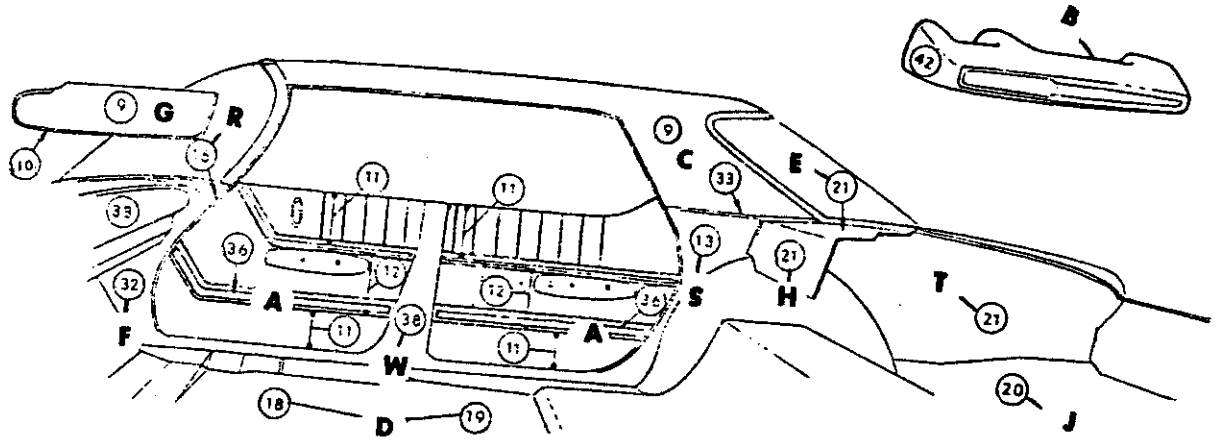

(FITTED DESIGN
-ALES)

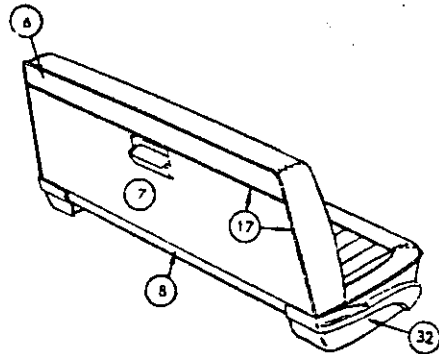
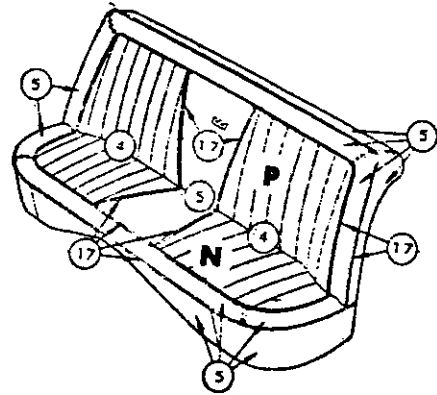
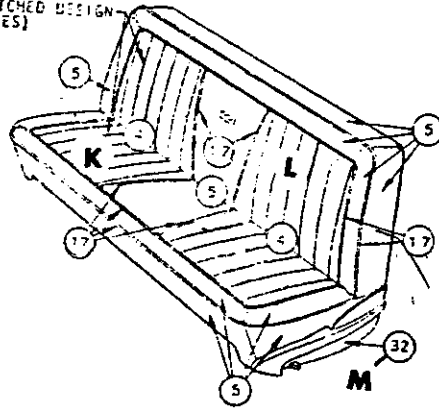

DISTRIBUTION OF MATERIAL

- 4 IMITATION LEATHER 25-DV-78
- 5 IMITATION LEATHER 28-AM-22
- 6 IMITATION LEATHER 19-C-22
- 7 IMITATION LEATHER 19A-C-22
- 8 IMITATION LEATHER 28A-AM-22
- 9 IMITATION LEATHER 15, 5-C-81
- 11 IMITATION LEATHER 19-DJ-22
- 12 IMITATION LEATHER 19A-DJ-22
- 13 IMITATION LEATHER 19D-C-22
- 16 LACE
- 17 EXTRUDED VINYL
- 18 FLOOR COVERING-FRONT-CARPET
- 19 FLOOR COVERING-REAR-CARPET
- 20 FLOOR COVERING-LUGG. COMPT. RUBBER
- 21 EMBOSSED CARDBOARD
- 30 PLASTIC
- 31 PAINT
- 32 METAL
- 33 MOULDING
- 35 POLYETHYLENE
- 36 MYLAR
- 38 MOULDED RESIN
- 42 PLASTISOL

Distribution Drawing Legend Page Appears Following Illustration Section

Codes 201, 203, 205, 206, 208

TCL-434

1963 CHRYSLER TC1-L 4 DOOR HARDTOP
IMITATION LEATHER TRIM

1963 CHRYSLER - T SERIES

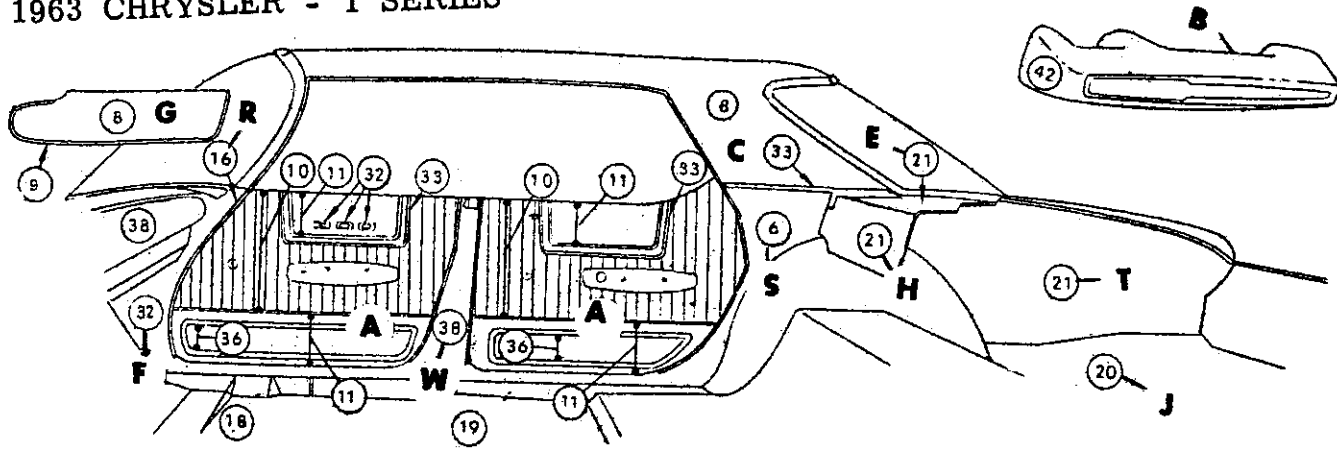

STITCHED DESIGN
UNDER-RIB

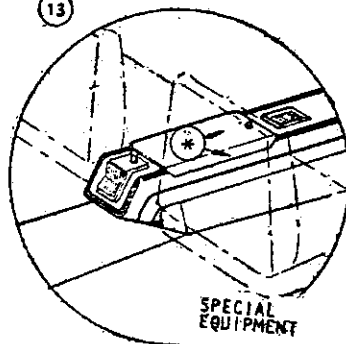
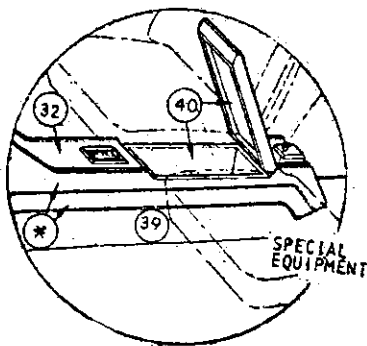
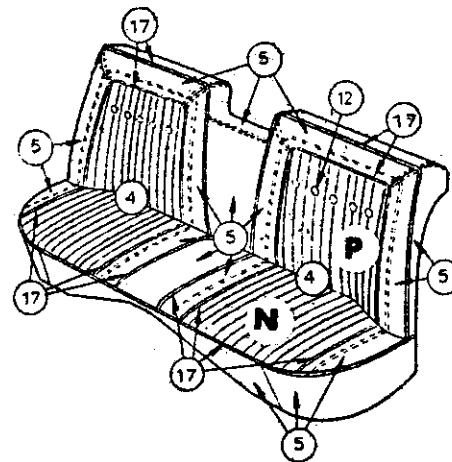
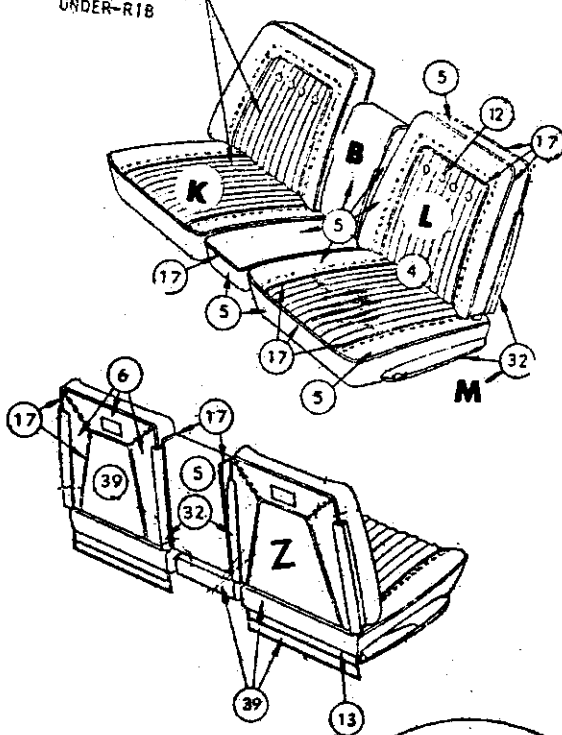

DISTRIBUTION OF MATERIAL

4	IMITATION LEATHER	34-DV-78
5	IMITATION LEATHER	28-AM-22
6	IMITATION LEATHER	19-C-22
8	IMITATION LEATHER	15, 5-C-81
10	IMITATION LEATHER	19-DJ-22
11	IMITATION LEATHER	19A-DJ-22
12	IMITATION LEATHER	19D-C-22
13	IMITATION LEATHER	28A-AM-22
16	LACE	
17	EXTRUDED VINYL	
18	FLOOR COVERING-FRONT-CARPET	
19	FLOOR COVERING-REAR-CARPET	
20	FLOOR COVERING-LUGG. COMPT. RUBBER	
21	EMBOSSED GARDBOARD	
30	PLASTIC	
31	PAINT	
32	METAL	
33	MOULDING	
35	POLYETHLENE	
36	MYLAR	
38	MOULDED RESIN	
39	CARPET	
40	FAN FLOCK	
42	PLASTISOL	

Distribution Drawing Legend Page Appears Following Illustration Section

Codes 221, 223, 225, 227, 228

TCM-434

1963 CHRYSLER TC2-M 4 DOOR HARDTOP
IMITATION LEATHER TRIM

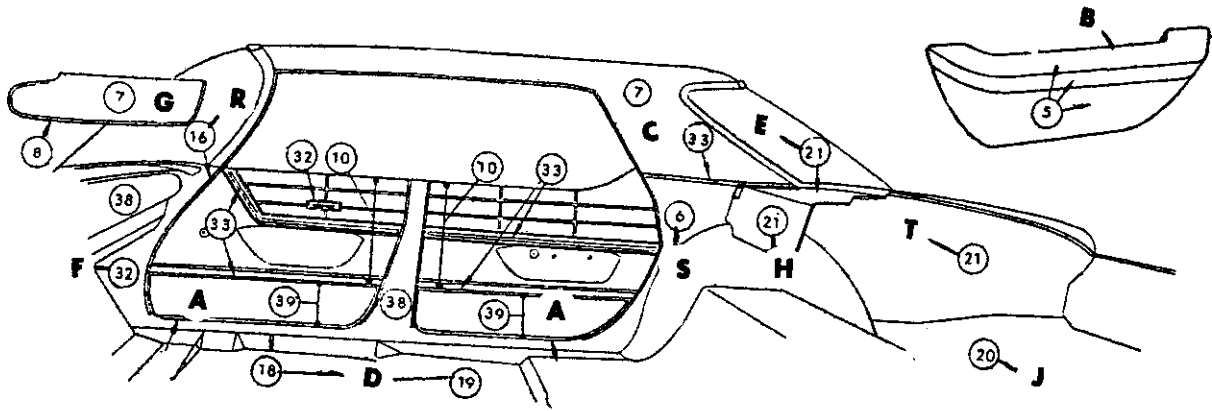

VULC. & STITCHED DESIGN

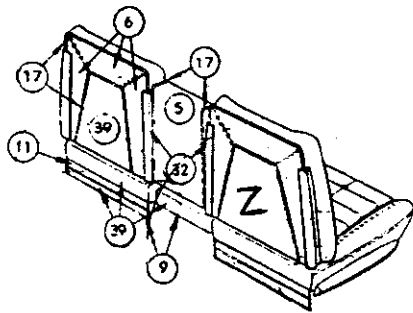
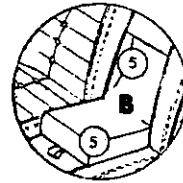
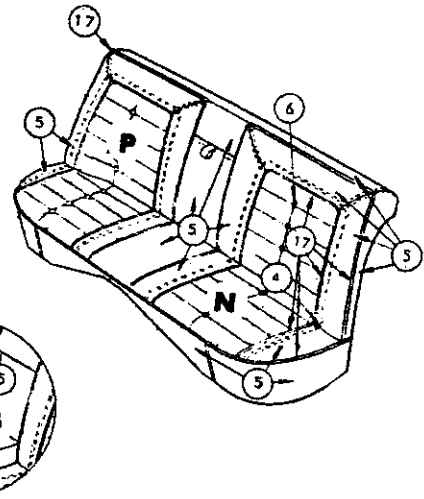
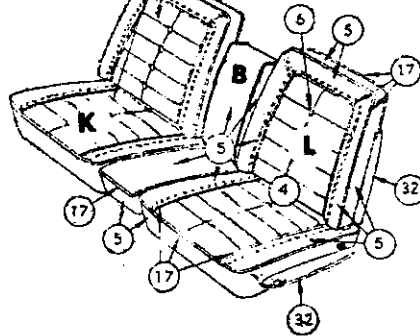

DISTRIBUTION OF MATERIAL

- 4 IMITATION LEATHER 34-DV-78
- 5 IMITATION LEATHER 28-AM-22
- 6 IMITATION LEATHER 19-C-22
- 7 IMITATION LEATHER 15.5-C-81
- 9 IMITATION LEATHER 19B-C-22
- 10 IMITATION LEATHER 19-DJ-22
- 11 IMITATION LEATHER 28A-AM-22
- 16 LACE
- 17 EXTRUDED VINYL
- 18 FLOOR COVERING-FRONT-CARPET
- 19 FLOOR COVERING-REAR-CARPET
- 20 FLOOR COVERING-LUGG. COMPT. CARPET
- 21 EMBOSSED CARDBOARD
- 30 PLASTIC
- 31 PAINT
- 32 METAL
- 33 MOULDING
- 35 POLYETHYLENE
- 36 MYLAR
- 38 MOULDED RESIN
- 39 CARPET

Distribution Drawing Legend Page Appears Following Illustration Section

Codes 231, 233, 235, 236, 238

TCH-434

1963 CHRYSLER TC3-H 4 DOOR HARDTOP
IMITATION LEATHER TRIM

1963 CHRYSLER - T SERIES

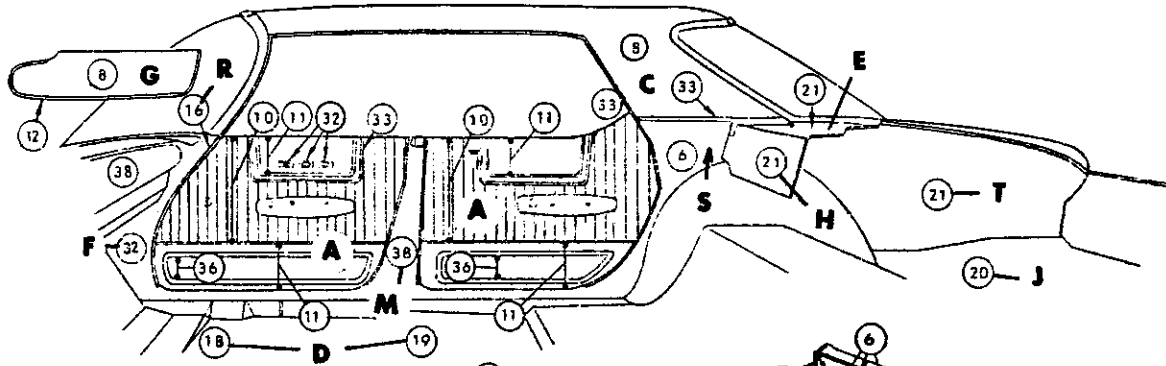

STITCHED DESIGN
(UNDER RIB)

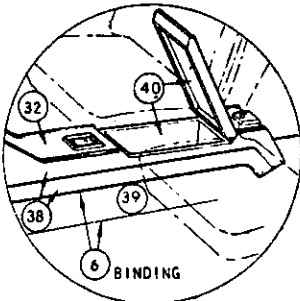
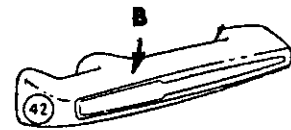
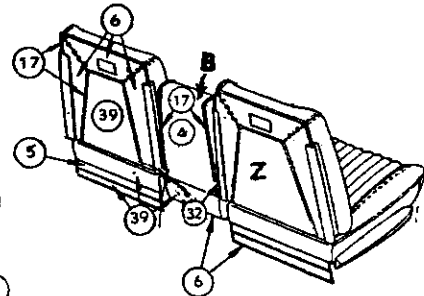
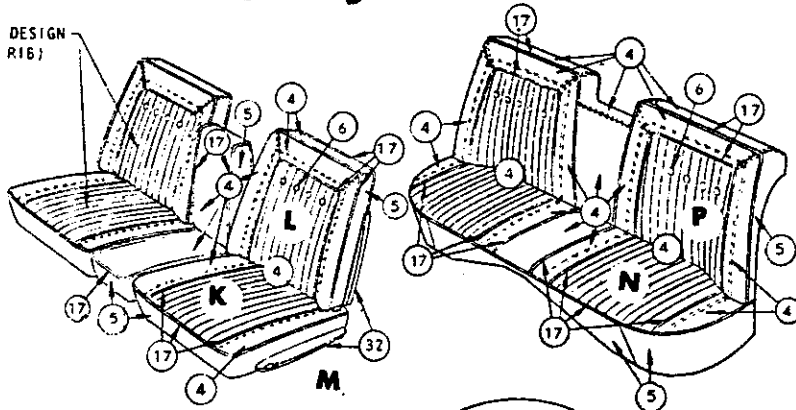

OPTIONAL
EQUIPMENT

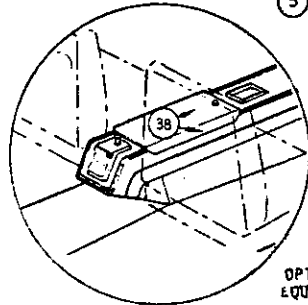

OPTIONAL
EQUIPMENT

DISTRIBUTION OF MATERIAL

- 4 LEATHER
- 5 IMITATION LEATHER 28-AM-22
- 6 IMITATION LEATHER 19-C-22
- 8 IMITATION LEATHER 15, 5-C-81
- 10 IMITATION LEATHER 19-D-J-22
- 11 IMITATION LEATHER 19A-DJ-22
- 12 IMITATION LEATHER 19A-C-22
- 16 LACE
- 17 EXTRUDED VINYL
- 18 FLOOR COVERING-FRONT CARPET
- 19 FLOOR COVERING-REAR CARPET
- 20 FLOOR COVERING-LUGG. COMPT, RUBBER
- 21 EMBOSSED CARDBOARD
- 30 PLASTIC
- 31 PAINT
- 32 METAL
- 33 MOULDING
- 35 POLYETHYLENE
- 36 MYLAR
- 38 MOULDED RESIN
- 39 CARPET
- 40 FAN FLOCK
- 42 PLASTISOL

Distribution Drawing Legend Page Appears Following Illustration Section

Code 245

TCM-433

1963 CHRYSLER TC2-M 4 DOOR HARDTOP
GENUINE LEATHER TRIM

1963 CHRYSLER - T SERIES

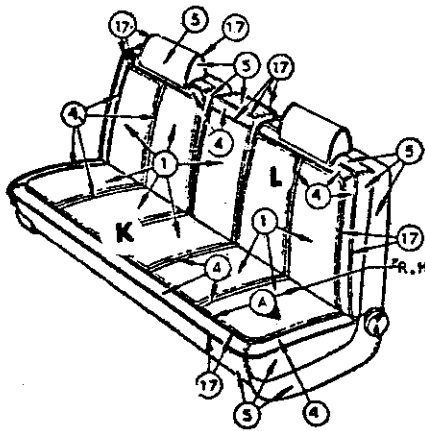
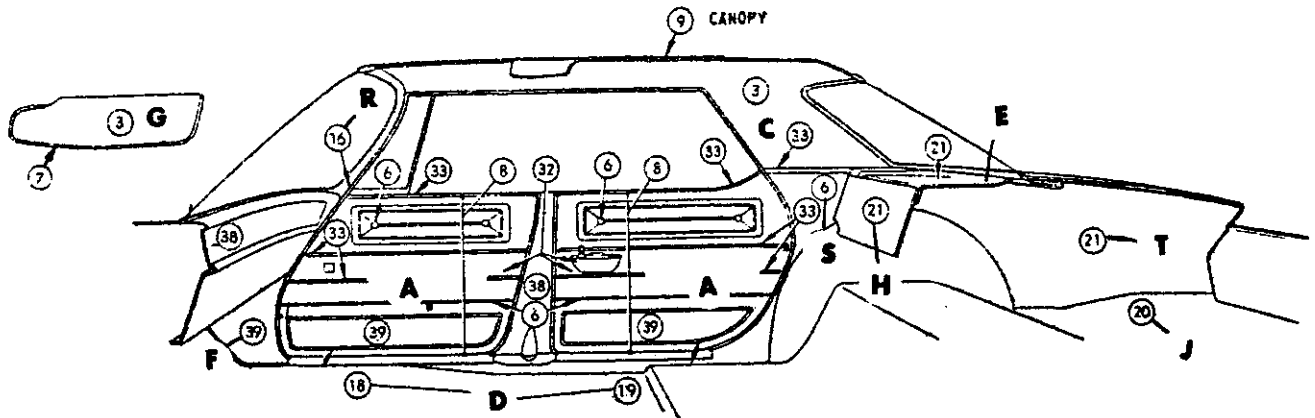

FRONT SEAT CENTER ARM REST

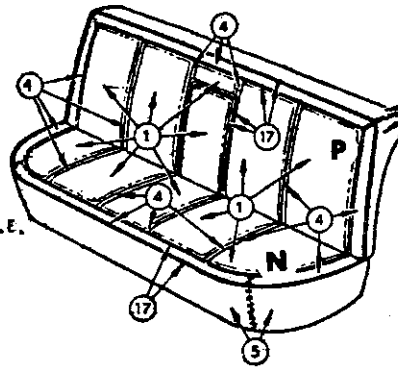

REAR SEAT CENTER ARM REST

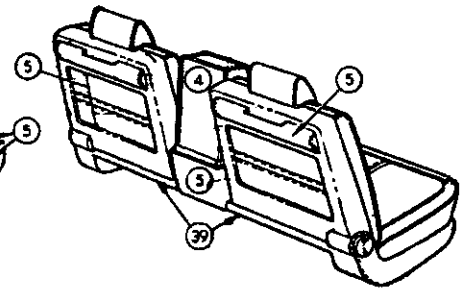

FRONT & REAR DOOR ARM REST

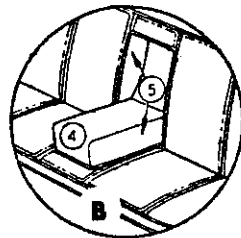
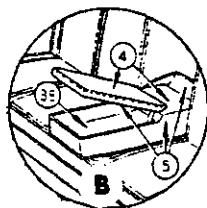

DISTRIBUTION OF MATERIAL

- 1 BODY CLOTH I
- 3 HEADLINING
- 4 GENUINE LEATHER
- 5 IMITATION LEATHER 38-DZ-22
- 6 IMITATION LEATHER 19-C-22
- 7 IMITATION LEATHER 19A-C-22
- 8 IMITATION LEATHER 30-AR-22
- 9 IMITATION LEATHER 37-DX-85
- 16 LACE
- 17 EXTRUDED VINYL
- 18 FLOOR COVERING-FRONT CARPET
- 19 FLOOR COVERING-REAR CARPET
- 20 FLOOR COVERING-LUGG. COMPT. CARPET
- 21 EMBOSSED CARDBOARD
- 30 PLASTIC
- 31 PAINT
- 32 METAL
- 33 MOULDING
- 36 MYLAR
- 38 MOULDED RESIN
- 39 CARPET

Distribution Drawing Legend Page Appears Following Illustration Section

Codes 151, 153

TCH-435

1963 CHRYSLER TC3-H 4 DOOR HARD TOP
CLOTH & LEATHER TRIM COMB.

1963 CHRYSLER - T SERIES

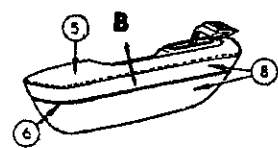
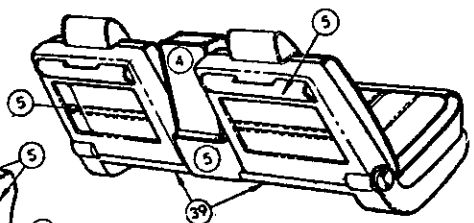
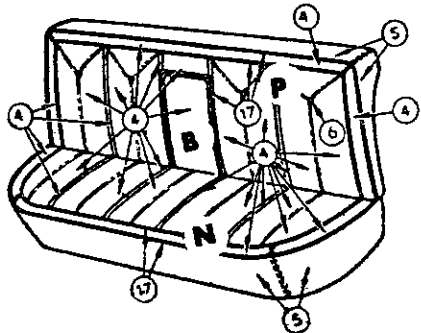
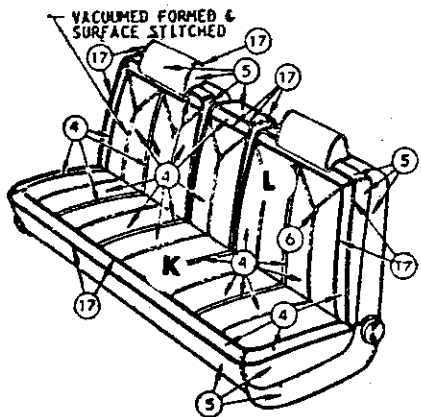
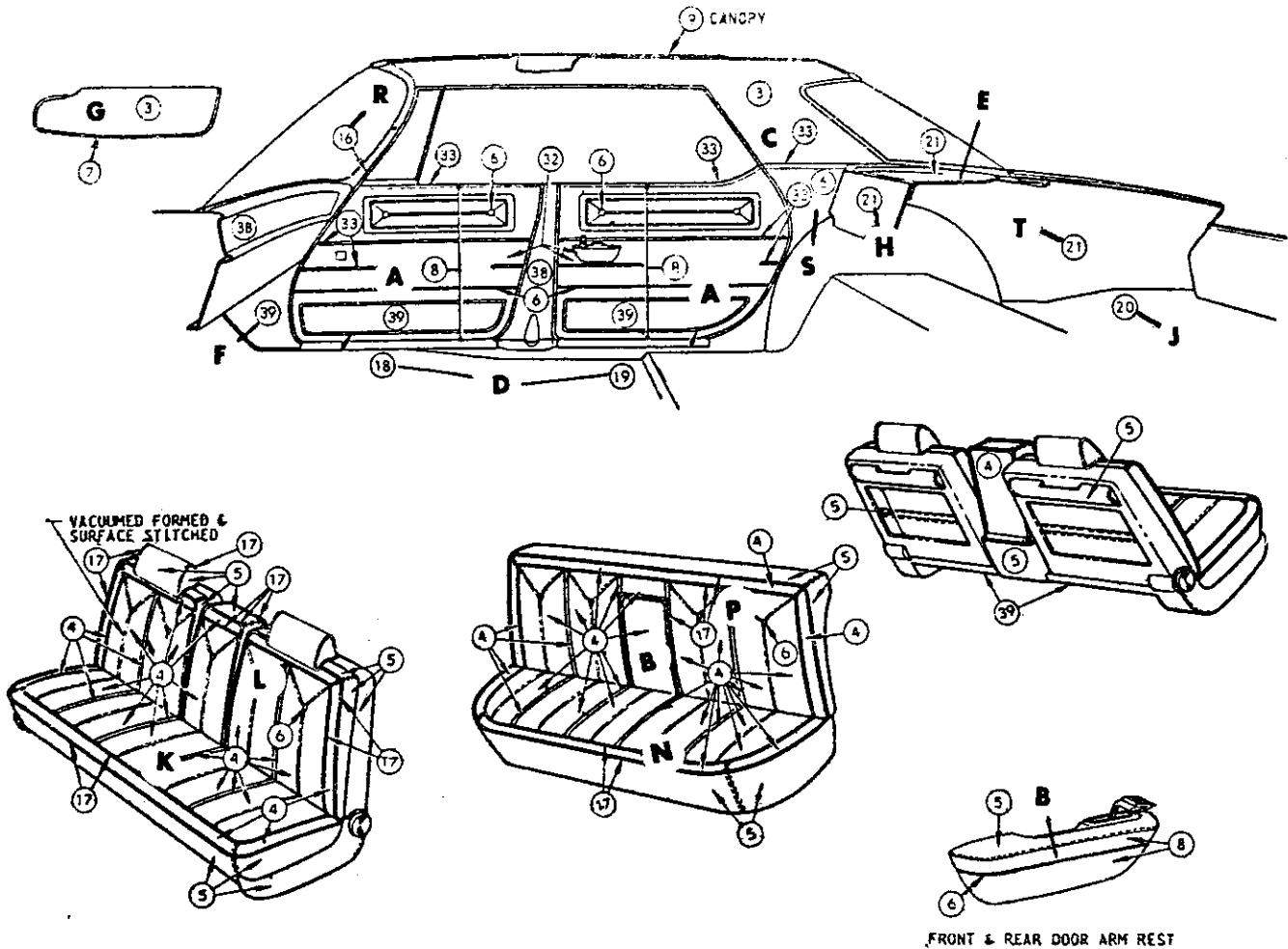

FRONT & REAR DOOR ARM REST

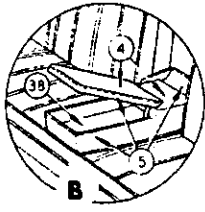

FRONT SEAT CENTER ARM REST

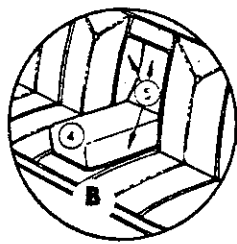

REAR SEAT CENTER ARM REST

DISTRIBUTION OF MATERIAL

- 3 HEADLINING
- 4 GENUINE LEATHER
- 5 IMITATION LEATHER 38-OZ-22
- 6 IMITATION LEATHER 19-C-22
- 7 IMITATION LEATHER 19A-C-22
- 8 IMITATION LEATHER 30-AR-22
- 9 IMITATION LEATHER 37-OX-85
- 16 LACE
- 17 EXTRUDED VINYL
- 18 FLOOR COVERING-FRONT CARPET
- 19 FLOOR COVERING-REAR CARPET
- 20 FLOOR COVERING-LUGG. COMPT. CARPET
- 21 EMBOSSED CARDBOARD
- 30 PLASTIC
- 31 PAINT
- 32 METAL
- 33 MOULDING
- 36 MYLAR
- 38 MOULDED RESIN
- 39 CARPET

Distribution Drawing Legend Page Appears Following Illustration Section

Codes 251, 253

TCH-433

1963 CHRYSLER TC3-H 4 DOOR HARD TOP
LEATHER TRIM

1963 CHRYSLER - T SERIES

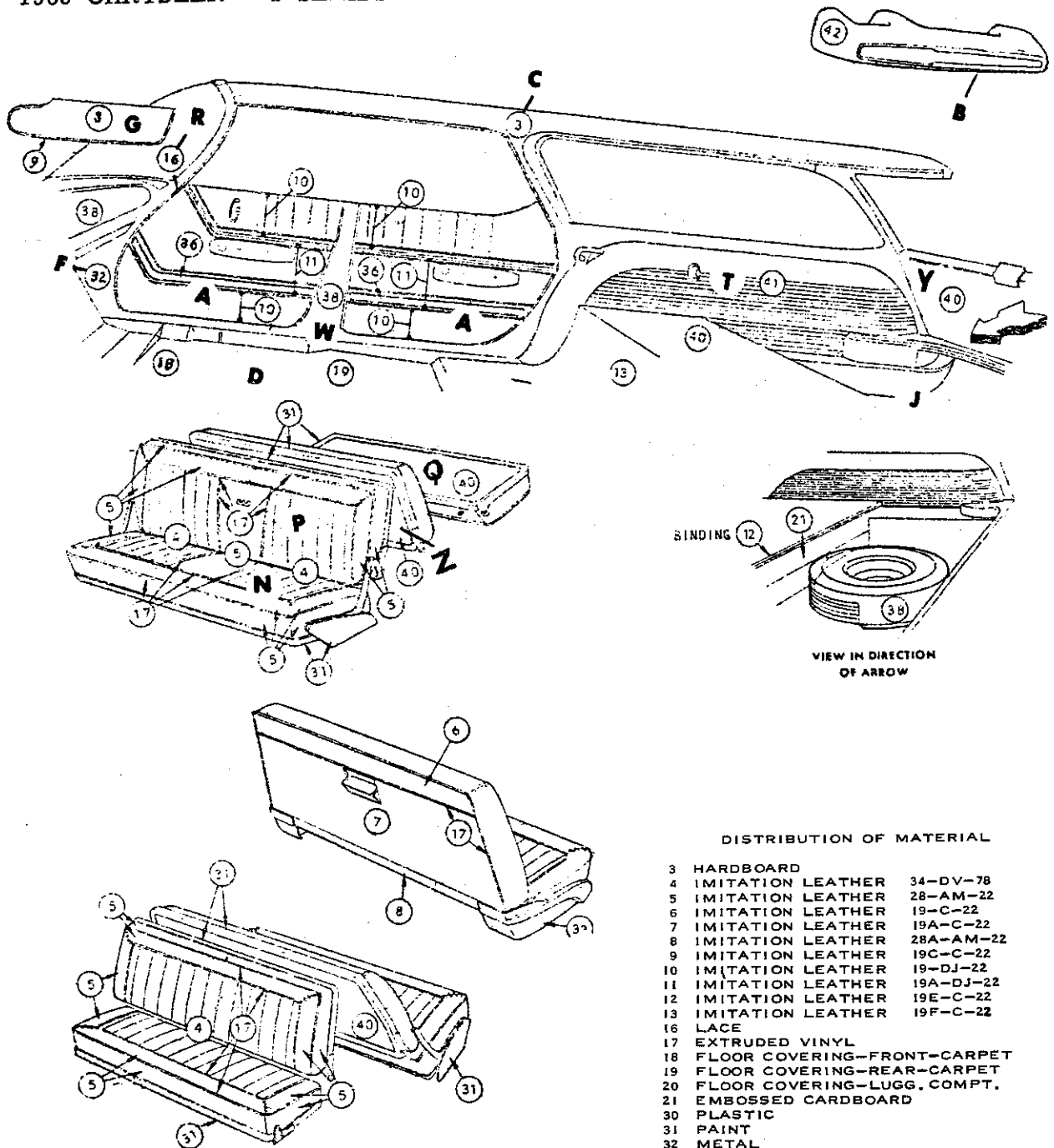

DISTRIBUTION OF MATERIAL

3	HARDBOARD	34-DV-78
4	IMITATION LEATHER	28-AM-22
5	IMITATION LEATHER	19-C-22
6	IMITATION LEATHER	19A-C-22
7	IMITATION LEATHER	19C-C-22
8	IMITATION LEATHER	28A-AM-22
9	IMITATION LEATHER	19C-C-22
10	IMITATION LEATHER	19-DJ-22
11	IMITATION LEATHER	19A-DJ-22
12	IMITATION LEATHER	19E-C-22
13	IMITATION LEATHER	19F-C-22
16	LACE	
17	EXTRUDED VINYL	
18	FLOOR COVERING-FRONT-CARPET	
19	FLOOR COVERING-REAR-CARPET	
20	FLOOR COVERING-LUGG. COMPT.	
21	EMBOSSED CARDBOARD	
30	PLASTIC	
31	PAINT	
32	METAL	
36	MYLAR	
38	MOULDED RESIN	
40	VINOLEUM	
41	MOULDED RUBBER	
42	PLASTISOL	

Distribution Drawing Legend Page Appears Following Illustration Section

Codes 201, 203, 205, 206, 208

TCL-464 1963 CHRYSLER TC1-L 4 DOOR HARDTOP SUBURBAN
IMITATION LEATHER TRIM

1963 CHRYSLER - T SERIES

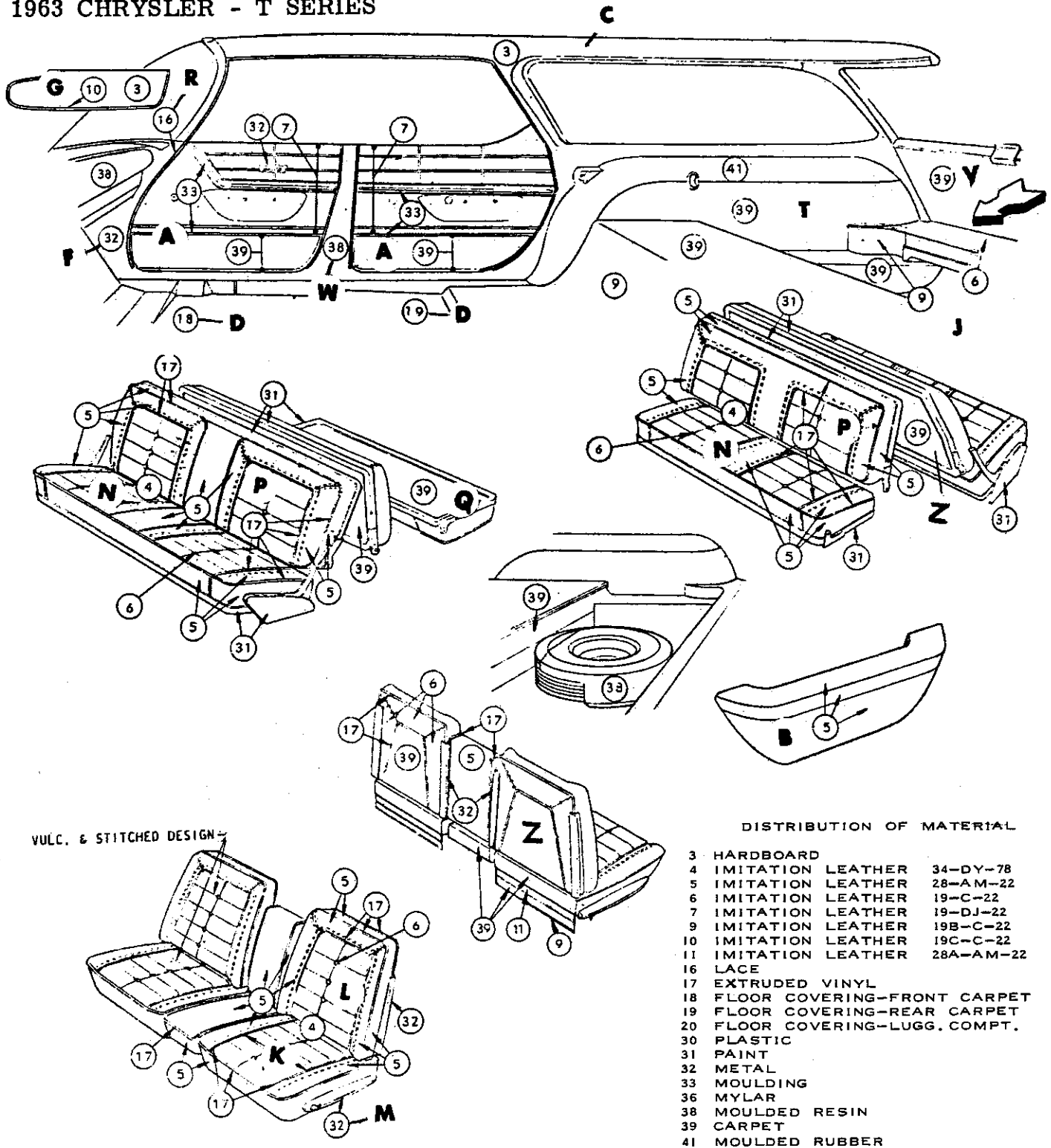

Distribution Drawing Legend Page Appears Following Illustration Section

Codes 231, 233, 235, 236, 238

TCH-464

1963 CHRYSLER TC3-H 4 DOOR HARD TOP
STATION WAGON
IMITATION LEATHER TRIM

1963 CHRYSLER - T SERIES

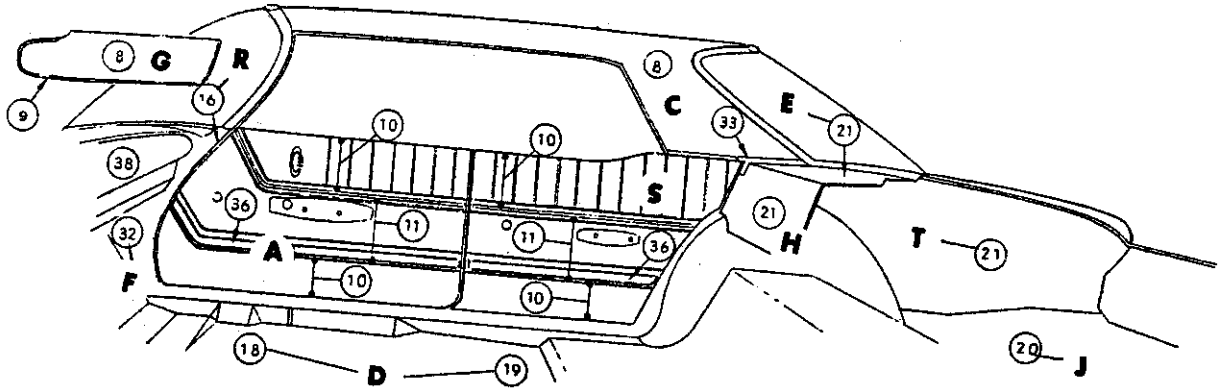

STITCHED DESIGN
(FALES)

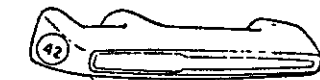
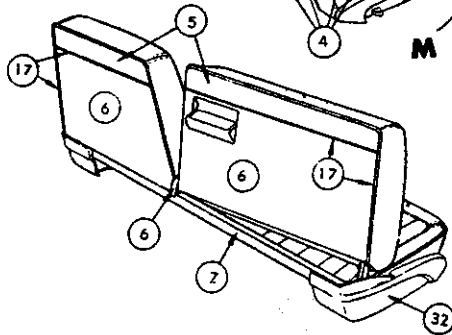
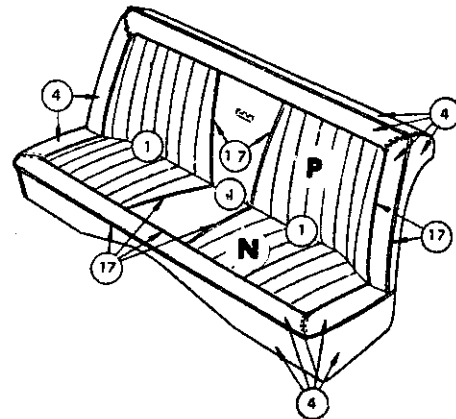
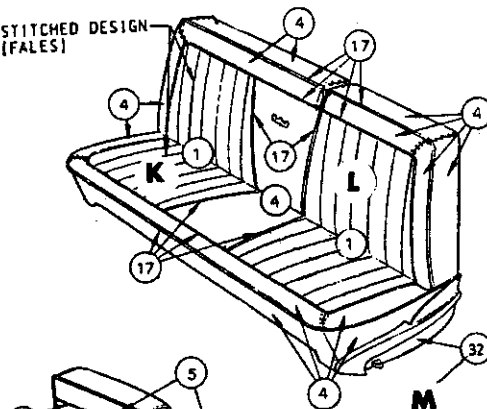

B



DISTRIBUTION OF MATERIAL

- 1 BODY CLOTH I
- 4 IMITATION LEATHER 28-AM-22
- 5 IMITATION LEATHER 19-C-22
- 6 IMITATION LEATHER 19A-C-22
- 7 IMITATION LEATHER 28A-AM-22
- 8 IMITATION LEATHER 15, 5-C-81
- 10 IMITATION LEATHER 19-DJ-22
- 11 IMITATION LEATHER 19A-DJ-22
- 16 LACE
- 17 EXTRUDED VINYL
- 18 FLOOR COVERING-FRONT-CARPET
- 19 FLOOR COVERING-REAR-CARPET
- 20 FLOOR COVERING-LUGG. COMPT. RUBBER
- 21 EMBOSSED CARDBOARD
- 30 PLASTIC
- 31 PAINT
- 32 METAL
- 33 MOULDING
- 35 POLYETHYLENE
- 36 MYLAR
- 38 MOULDED RESIN
- 42 PLASTISOL

Distribution Drawing Legend Page Appears Following Illustration Section

Codes 111, 112, 113, 115

TCL-231

1963 CHRYSLER TC1-L 2 DOOR HARDTOP
CLOTH & IMITATION LEATHER TRIM

1963 CHRYSLER - T SERIES

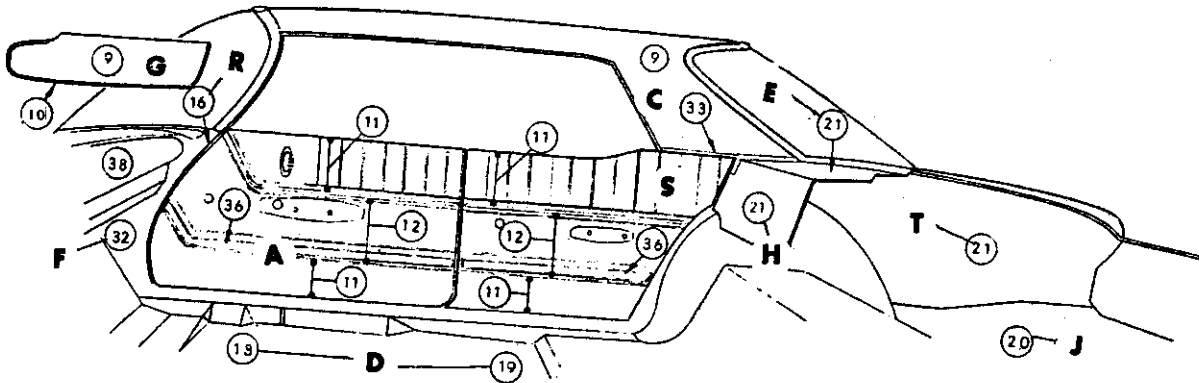

STITCHED DESIGN
(IF APPLICABLE)

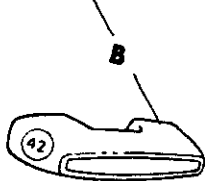
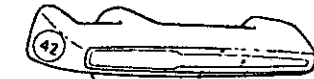
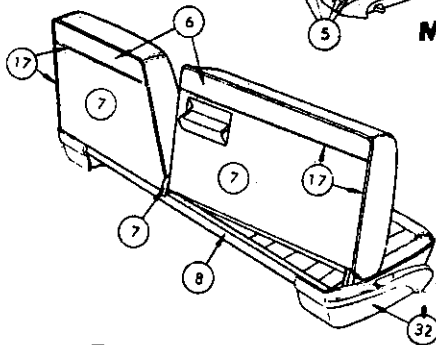
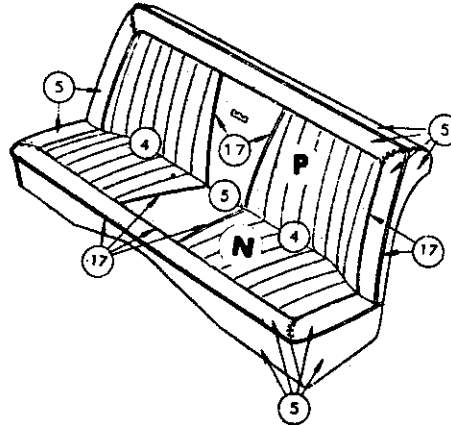
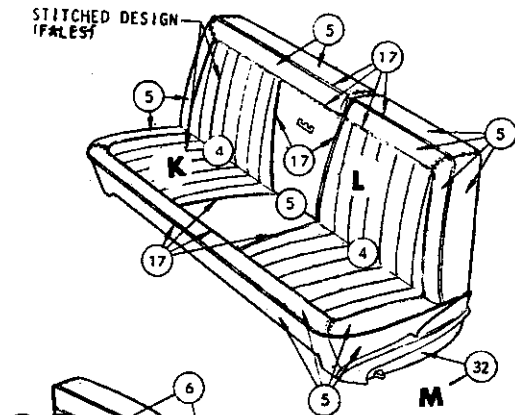

DISTRIBUTION OF MATERIAL

- | | | |
|----|------------------------------------|------------|
| 4 | IMITATION LEATHER | 34-DV-78 |
| 5 | IMITATION LEATHER | 28-AM-22 |
| 6 | IMITATION LEATHER | 19-C-22 |
| 7 | IMITATION LEATHER | 19A-C-22 |
| 8 | IMITATION LEATHER | 28A-AM-22 |
| 9 | IMITATION LEATHER | 15, 5-C-81 |
| 11 | IMITATION LEATHER | 19-DJ-22 |
| 12 | IMITATION LEATHER | 19A-DJ-22 |
| 16 | LACE | |
| 17 | EXTRUDED VINYL | |
| 18 | FLOOR COVERING-FRONT-CARPET | |
| 19 | FLOOR COVERING-REAR-CARPET | |
| 20 | FLOOR COVERING-LUGG. COMPT. RUBBER | |
| 21 | EMBOSSED CARDBOARD | |
| 30 | PLASTIC | |
| 31 | PAINT | |
| 32 | METAL | |
| 35 | POLYETHYLENE | |
| 36 | MYLAR | |
| 38 | MOULDED RESIN | |
| 42 | PLASTISOL | |

Distribution Drawing Legend Page Appears Following Illustration Section

Codes 201, 203, 205, 206, 208

TCL-234

1963 CHRYSLER TC1-L 2 DOOR HARDTOP
IMITATION LEATHER TRIM

1953 CHRYSLER - T SERIES

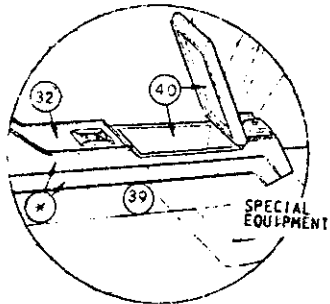
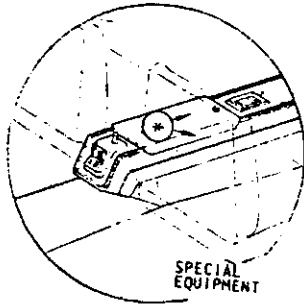
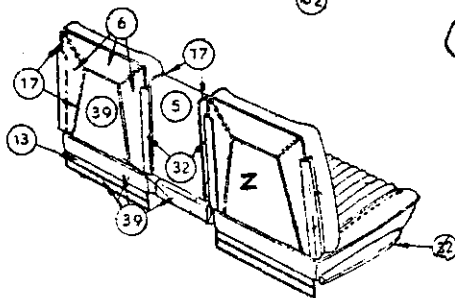
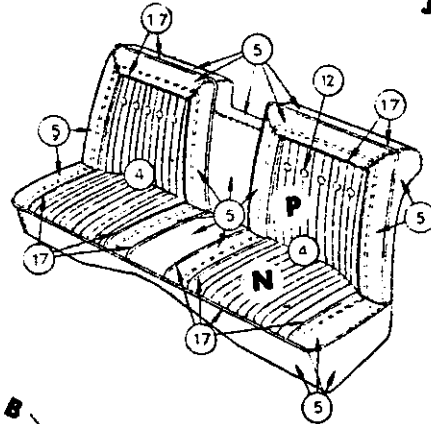
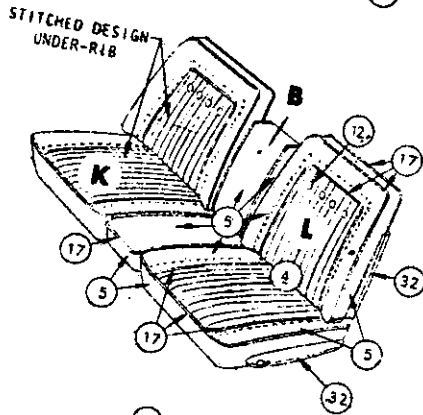
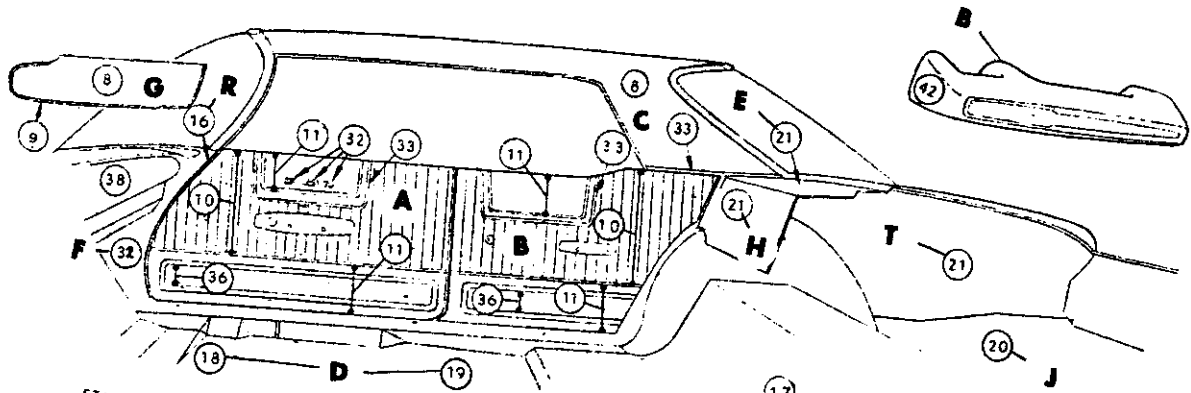

DISTRIBUTION OF MATERIAL

4	IMITATION LEATHER	34-DY-78
5	IMITATION LEATHER	28-AM-22
6	IMITATION LEATHER	19-C-22
8	IMITATION LEATHER	15, 5-C-81
9	IMITATION LEATHER	19B-C-22
10	IMITATION LEATHER	19-DJ-22
11	IMITATION LEATHER	19A-DJ-22
12	IMITATION LEATHER	19D-C-22
13	IMITATION LEATHER	28A-AM-22
16	LACE	
17	EXTRUDED VINYL	
18	FLOOR COVERING-FRONT-CARPET	
19	FLOOR COVERING-REAR-CARPET	
20	FLOOR COVERING-LUGG.COMPT.-RUBBER	
21	EMBOSSED CARDBOARD	
30	PLASTIC	
31	PAINT	
32	METAL	
35	POLYETHYLENE	
36	MYLAR	
38	MOULDED RESIN	
39	CARPET	
40	FAN FLOCK	
42	PLASTISOL	

Distribution Drawing Legend Page Appears Following Illustration Section

Codes 221, 223, 225, 227, 228

TCM-234

1963 CHRYSLER TC2-M 2 DOOR HARDTOP
IMITATION LEATHER TRIM

1963 CHRYSLER - T SERIES

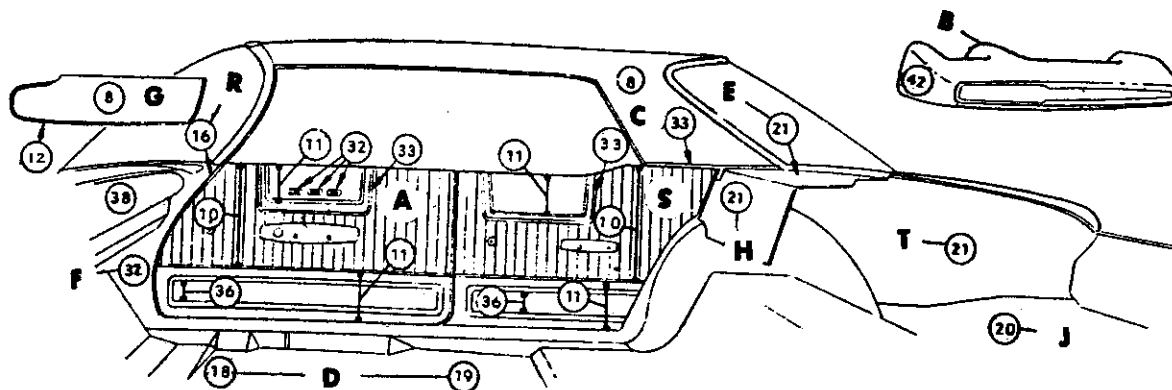

STITCHED DESIGN
(UNDER RIB)

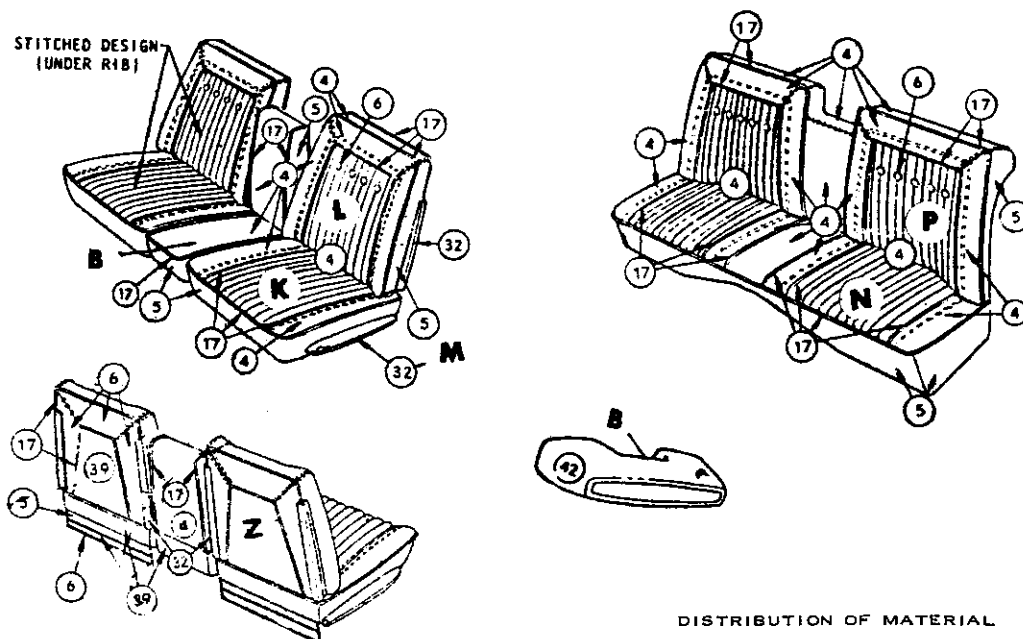

DISTRIBUTION OF MATERIAL

- 4 LEATHER
- 5 IMITATION LEATHER 28-AM-22
- 6 IMITATION LEATHER 19-C-22
- 8 IMITATION LEATHER 15, 5-C-81
- 10 IMITATION LEATHER 19-DJ-22
- 11 IMITATION LEATHER 19A-DJ-22
- 16 LACE
- 17 EXTRUDED VINYL
- 18 FLOOR COVERING-FRONT-CARPET
- 19 FLOOR COVERING-REAR-CARPET
- 20 FLOOR COVERING-LUGG. COMPT. RUBBER
- 21 EMBOSSED CARDBOARD
- 30 PLASTIC
- 31 PAINT
- 32 METAL
- 33 MOULDING
- 35 POLYETHYLENE
- 36 MYLAR
- 38 MOULDED RESIN
- 39 CARPET
- 40 FAN FLOCK
- 42 PLASTISOL
- 46 CARPET (300J ONLY)

OPTIONAL EQUIPMENT

OPTIONAL EQUIPMENT

Distribution Drawing Legend Page Appears Following Illustration Section

Code 245

TCM-233

1963 CHRYSLER TC2-M 2 DOOR HARDTOP
GENUINE LEATHER TRIM

1963 CHRYSLER - T SERIES

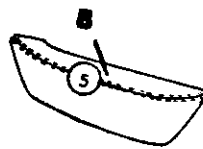
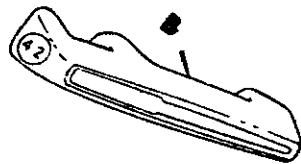
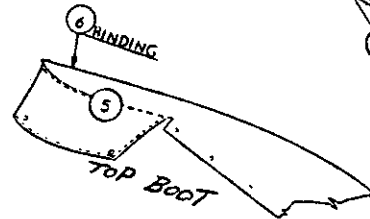
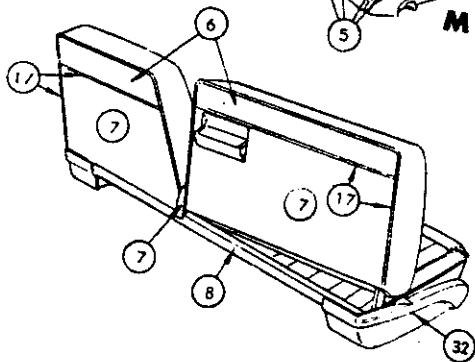
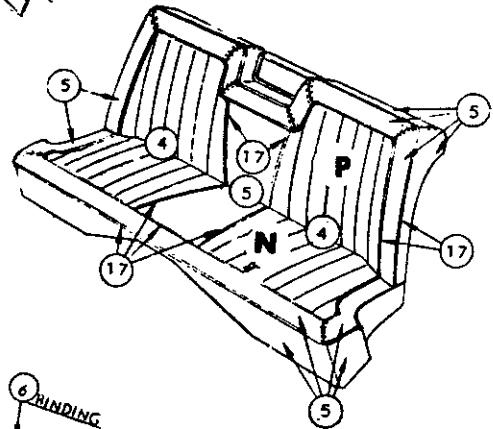
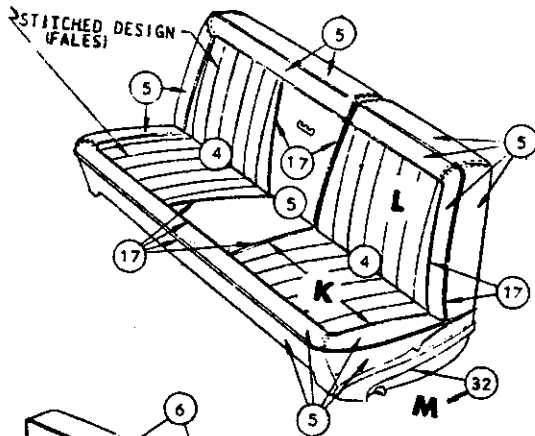
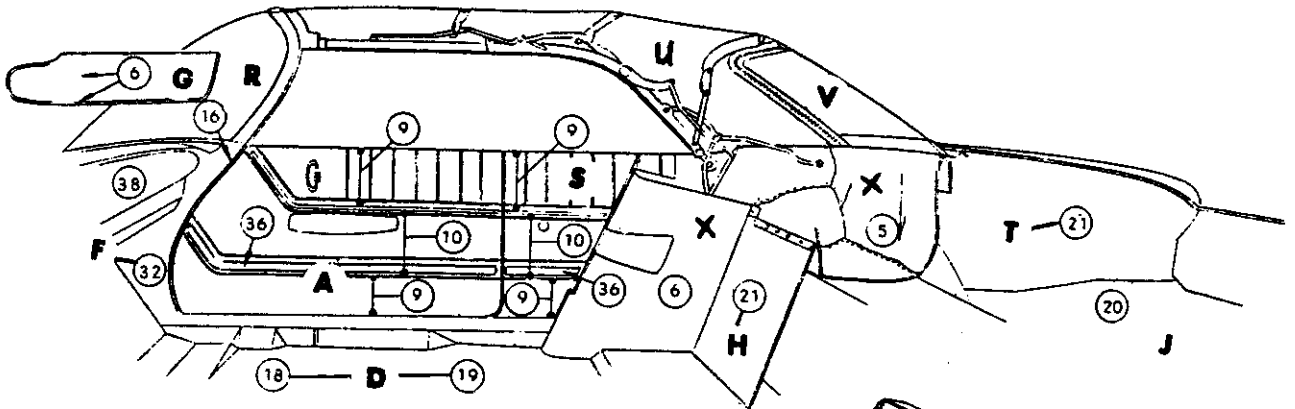

DISTRIBUTION OF MATERIAL

4	IMITATION LEATHER	25-DV-78
5	IMITATION LEATHER	28-AM-22
6	IMITATION LEATHER	19-C-22
7	IMITATION LEATHER	19A-C-22
8	IMITATION LEATHER	28A-AM-22
9	IMITATION LEATHER	19-DJ-22
10	IMITATION LEATHER	19A-DJ-22
16	LACE	
17	EXTRUDED VINYL	
18	FLOOR COVERING-FRONT-CARPET	
19	FLOOR COVERING-REAR-CARPET	
20	FLOOR COVERING-LUGG. COMPT. RUBBER	
21	EMBOSSED CARDBOARD	
30	PLASTIC	
31	PAINT	
32	METAL	
33	MOULDING	
35	POLYETHYLENE	
36	MYLAR	
38	MOULDED RESIN	
42	PLASTISOL	

Distribution Drawing Legend Page Appears Following Illustration Section

Codes 201, 203, 205, 206, 208

TCL-274

1963 CHRYSLER TC1-L CONVERTIBLE COUPE
IMITATION LEATHER TRIM

1963 CHRYSLER - T SERIES

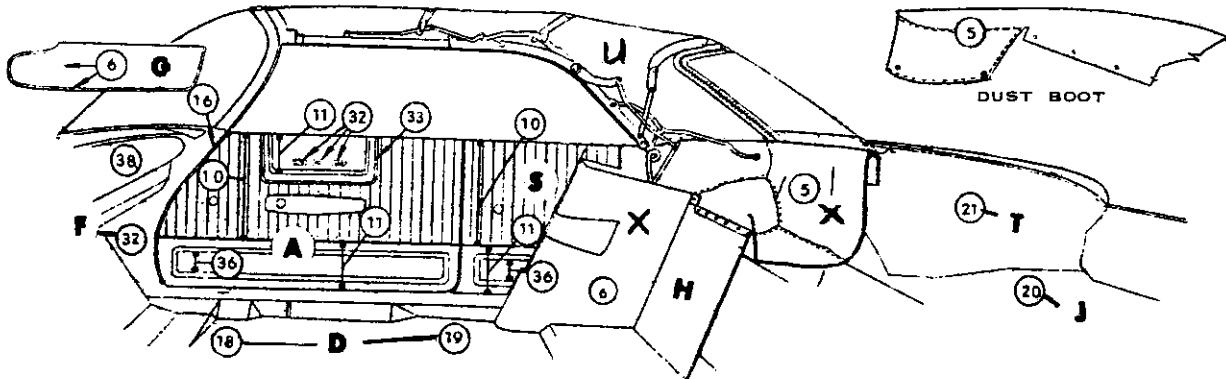

STITCHED DESIGN
UNDER-RIB

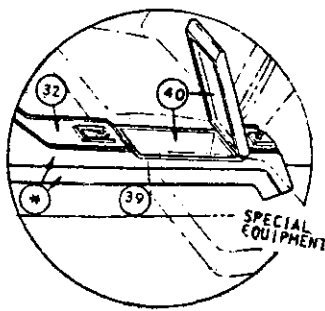
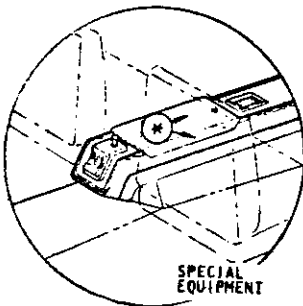
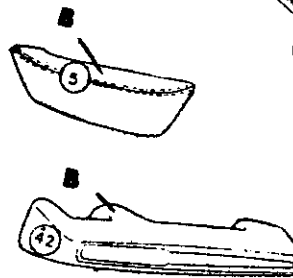
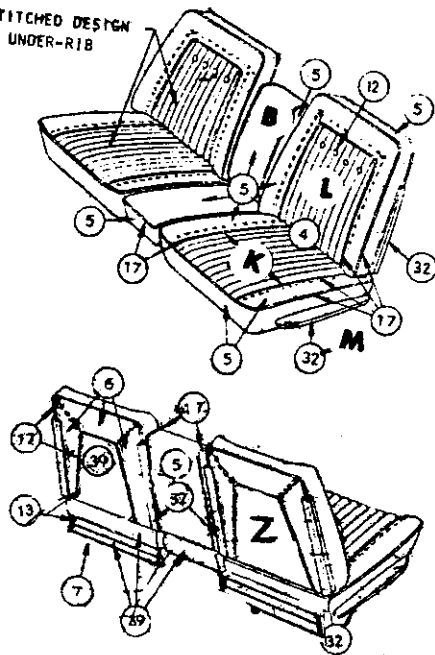

DISTRIBUTION OF MATERIAL

4	IMITATION LEATHER	34-DV-78
5	IMITATION LEATHER	28-AM-22
6	IMITATION LEATHER	19-C-22
7	IMITATION LEATHER	19A-C-22
10	IMITATION LEATHER	19-DJ-22
11	IMITATION LEATHER	19A-DJ-22
12	IMITATION LEATHER	19D-C-22
13	IMITATION LEATHER	28A-AM-22
16	LACE	
17	EXTRUDED VINYL	
18	FLOOR COVERING-FRONT-CARPET	
19	FLOOR COVERING-REAR-CARPET	
20	FLOOR COVERING-LUGG.COMPT.RUBBER	
21	EMBOSSED CARDBOARD	
30	PLASTIC	
31	PAINT	
32	METAL	
33	MOULDING	
35	POLYETHYLENE	
36	MYLAR	
38	MOULDED RESIN	
39	CARPET	
40	FAN FLOCK	
42	PLASTISOL	

Distribution Drawing Legend Page Appears Following Illustration Section

Codes 221, 223, 225, 227, 228

TCM-274

1963 CHRYSLER TC2-M CONVERTIBLE COUPE
IMITATION LEATHER TRIM

1963 CHRYSLER - T SERIES

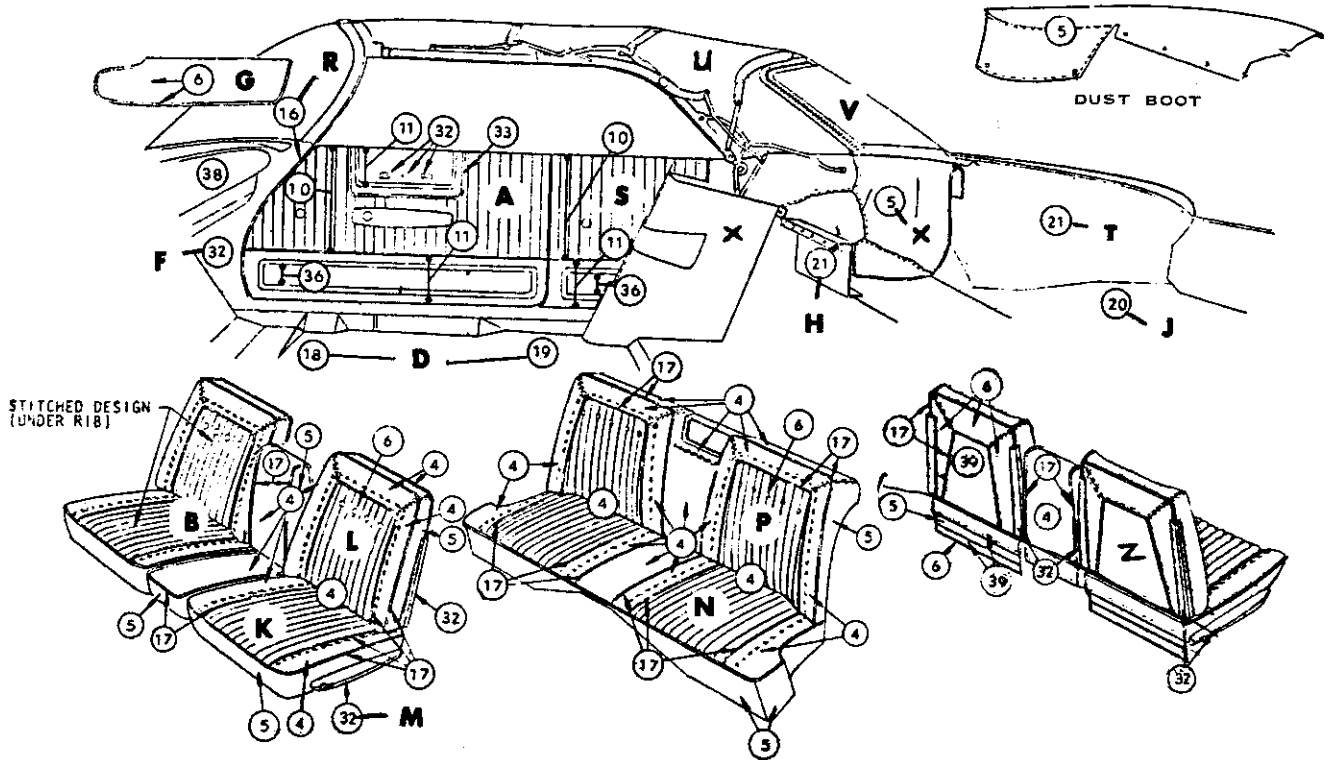

STITCHED DESIGN
(UNDER RIB)

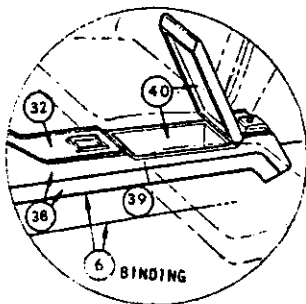

OPTIONAL
EQUIPMENT

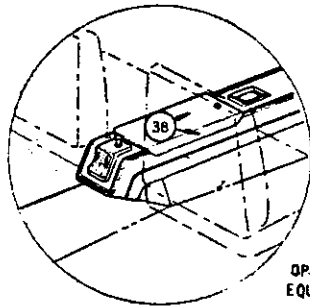

OPTIONAL
EQUIPMENT

DISTRIBUTION OF MATERIAL

- 4 LEATHER
- 5 IMITATION LEATHER 28-AM-22
- 6 IMITATION LEATHER 19-C-22
- 10 IMITATION LEATHER 19-DJ-22
- 11 IMITATION LEATHER 19A-DJ-22
- 16 LACE
- 17 EXTRUDED VINYL
- 18 FLOOR COVERING-FRONT CARPET
- 19 FLOOR COVERING-REAR CARPET
- 20 FLOOR COVERING-LUGG. COMPT. RUBBER
- 21 EMBOSSED CARDBOARD
- 30 PLASTIC
- 31 PAINT
- 32 METAL
- 33 MOULDING
- 35 POLYETHYLENE
- 36 MYLAR
- 38 MOULDED RESIN
- 39 CARPET
- 40 FAN FLOCK
- 42 PLASTISOL

Distribution Drawing Legend Page Appears Following Illustration Section

Code 245

TCM-273

1963 CHRYSLER TC2-M CONVERTIBLE COUPE
GENUINE LEATHER TRIM

1963 CHRYSLER - T SERIES

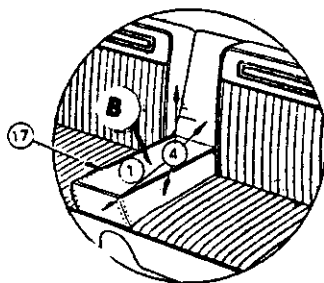
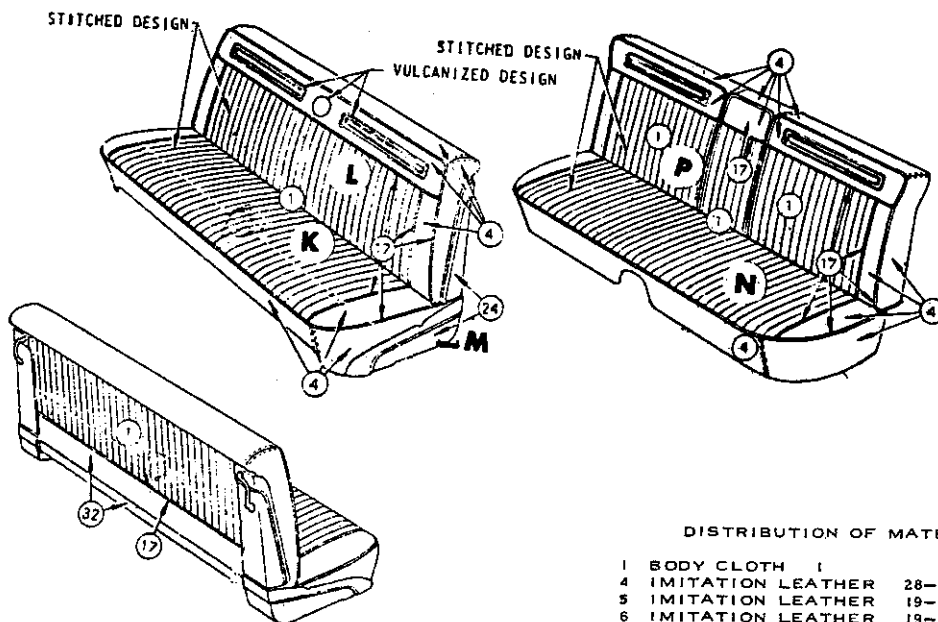
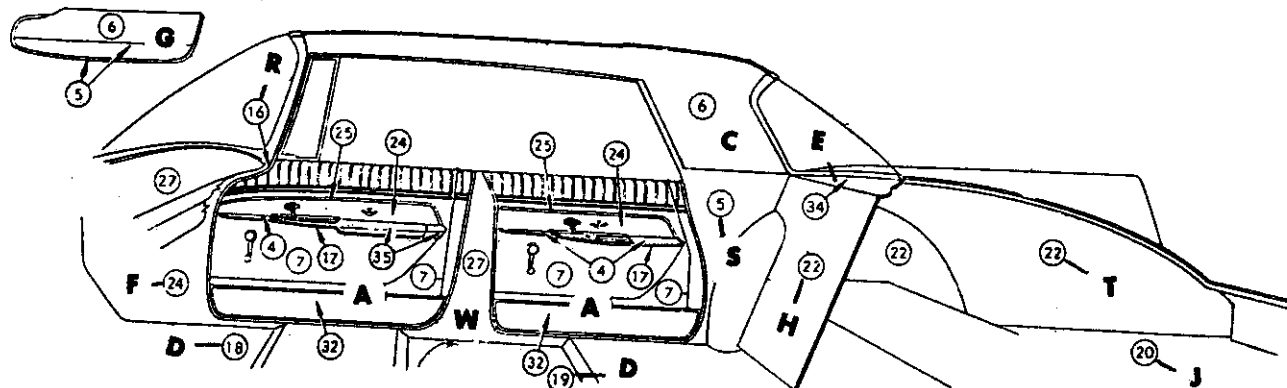

DISTRIBUTION OF MATERIAL

- 1 BODY CLOTH
- 4 IMITATION LEATHER
- 5 IMITATION LEATHER
- 6 IMITATION LEATHER
- 7 IMITATION LEATHER
- 8 IMITATION LEATHER
- 16 LACE
- 17 EXTRUDED VINYL
- 18 FLOOR COVERING-FRONT-CARPET
- 19 FLOOR COVERING-REAR-CARPET
- 20 FLOOR COVERING-LUGG. COMPT. CARPET
- 21 CARDBOARD
- 22 EMBOSSSED CARDBOARD
- 23 PAINT
- 24 METAL
- 25 MOULDING
- 26 MYLAR
- 27 MOULDED RESIN
- 28 MOULDED RUBBER
- 29 MOULDED VINYL
- 32 CARPET
- 33 PLASTIC
- 34 WOVEN PAPER
- 35 PLASTISOL

Distribution Drawing Legend Page Appears Following Illustration Section

Codes 901, 903, 904, 908, 909

TYL-431

1963 IMPERIAL TY1-L 4 DOOR HARDTOP
CLOTH & IMITATION LEATHER

1963 IMPERIAL - T SERIES

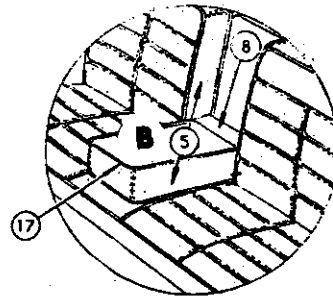
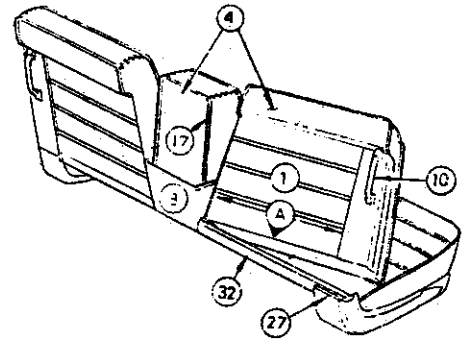
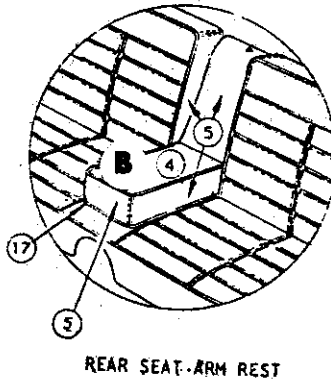
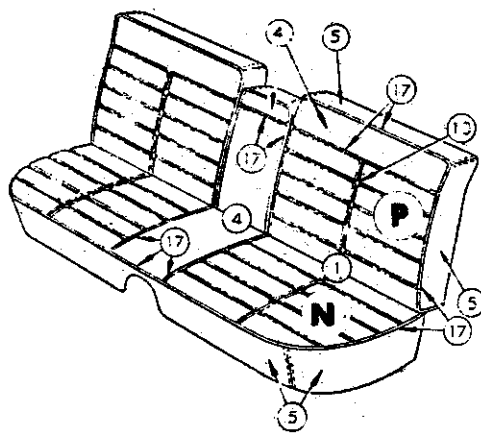
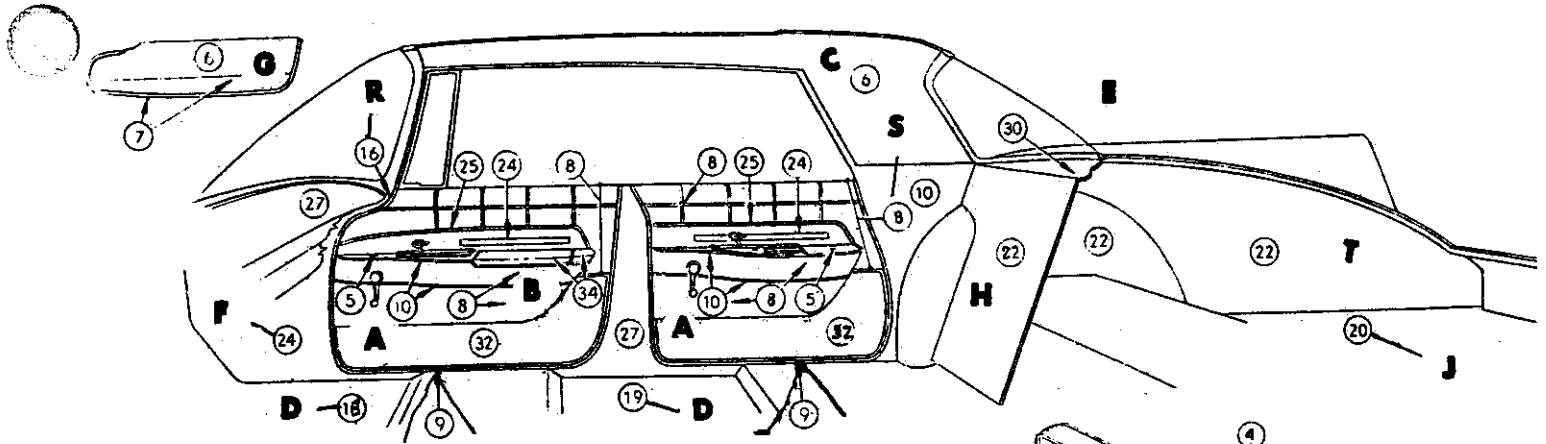

VULCANTZED & STITCHEQ DESIGN

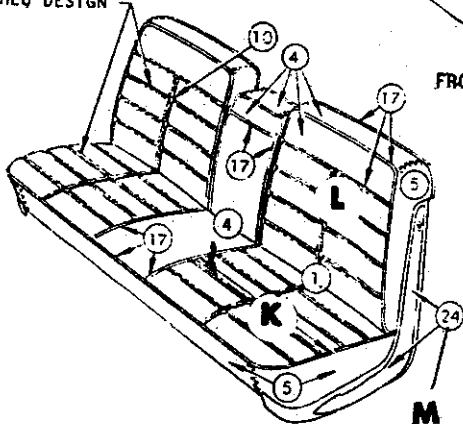

DISTRIBUTION OF MATERIAL

- 1 BODY CLOTH I
- 4 GENUINE LEATHER
- 5 IMITATION LEATHER 28-AM-22
- 6 IMITATION LEATHER 19-C-5
- 7 IMITATION LEATHER 19-C-22
- 8 IMITATION LEATHER 22-AR-22
- 9 IMITATION LEATHER 19A-C-22
- 10 IMITATION LEATHER 19B-C-22
- 16 LACE
- 17 EXTRUDED VINYL
- 18 FLOOR COVERING-FRONT CARPET
- 19 FLOOR COVERING-REAR CARPET
- 20 FLOOR COVERING-LUGG. COMPT. CARPET
- 22 EMBOSSED CARDBOARD
- 23 PAINT
- 24 METAL
- 25 MOULDING
- 26 MYLAR
- 27 MOULDED RESIN
- 28 MOULDED RUBBER
- 29 MOULDED VINYL
- 32 CARPET
- 33 PLASTIC
- 34 PLASTISOL

Distribution Drawing Legend Page Appears Following Illustration Section

Codes 921, 923, 924, 925, 928, 929

TYM-435

1963 IMPERIAL TY1-M 4 DOOR HARD TOP
CLOTH & LEATHER TRIM

1963 CHRYSLER - T SERIES

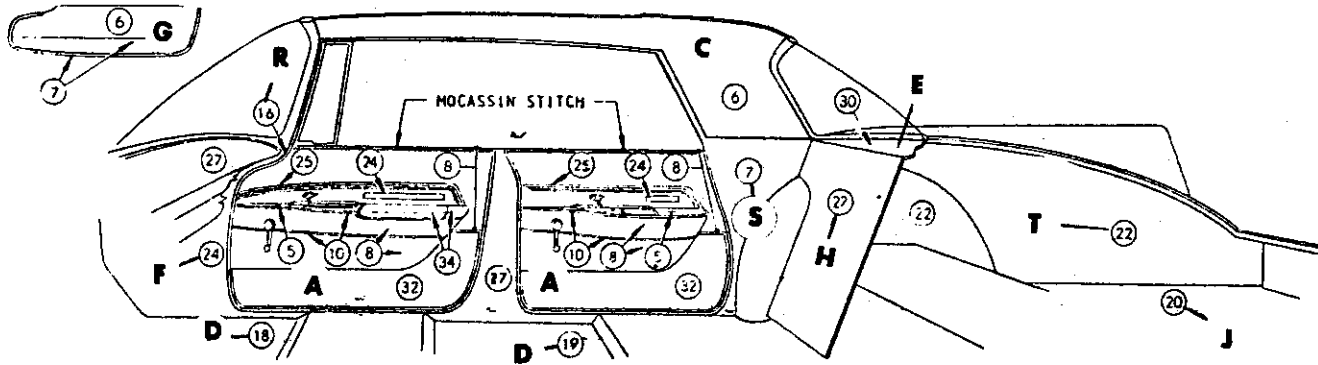

VULCANIZED & STITCHED DESIGN.

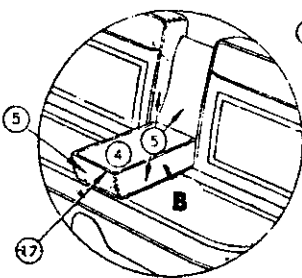
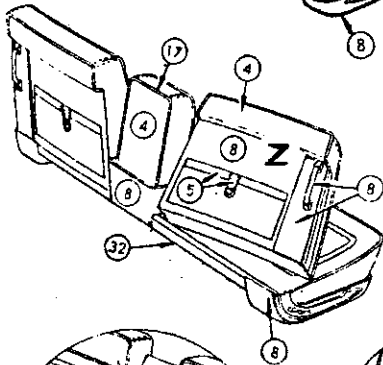
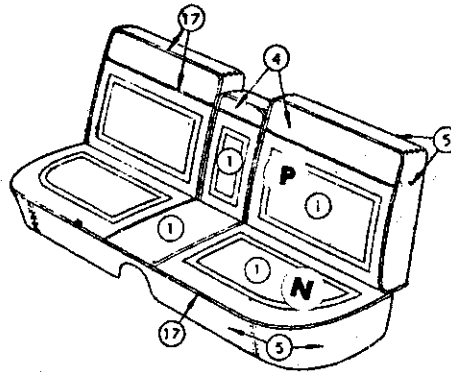
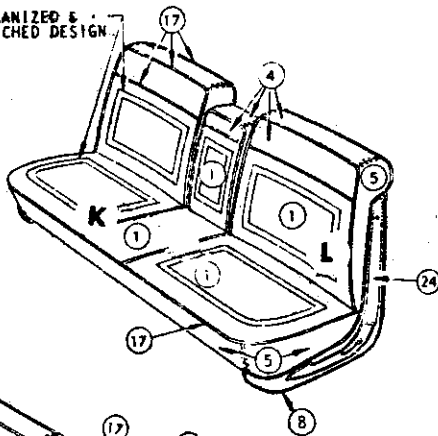

REAR SEAT ARM REST

FRONT SEAT ARM REST

DISTRIBUTION OF MATERIAL

- 1 BODY CLOTH
- 4 GENUINE LEATHER
- 5 IMITATION LEATHER
- 6 IMITATION LEATHER
- 7 IMITATION LEATHER
- 8 IMITATION LEATHER
- 9 IMITATION LEATHER
- 10 IMITATION LEATHER
- 16 LACE
- 17 EXTRUDED VINYL
- 18 FLOOR COVERING-FRONT-CARPET
- 19 FLOOR COVERING-REAR-CARPET
- 20 FLOOR COVERING-LUGG. COMPT. CARPET
- 22 EMBOSSED CARDBOARD
- 23 PAINT
- 24 METAL
- 25 MOULDING
- 26 MYLAR
- 27 MOULDED RESIN
- 28 MOULDED RUBBER
- 29 MOULDED VINYL
- 30 WOVEN PAPER
- 32 CARPET
- 33 PLASTIC
- 34 PLASTISOL

Distribution Drawing Legend Page Appears Following Illustration Section

Codes 941, 943, 944, 949

TYH-435

1963 IMPERIAL TY1-H 4 DOOR HARDTOP
CLOTH & LEATHER TRIM

1963 CHRYSLER - T SERIES

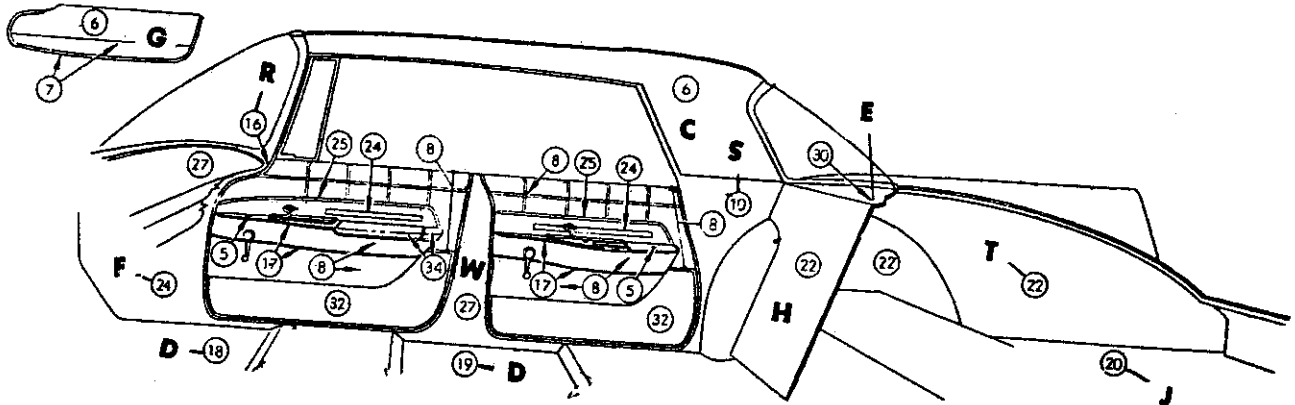

VULCANIZED & STITCHED DESIGN

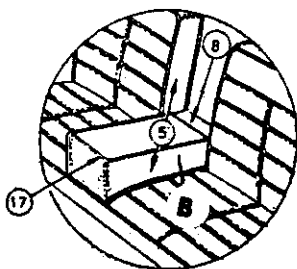
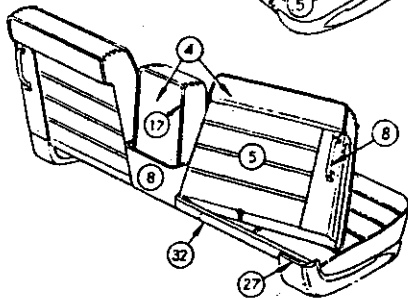
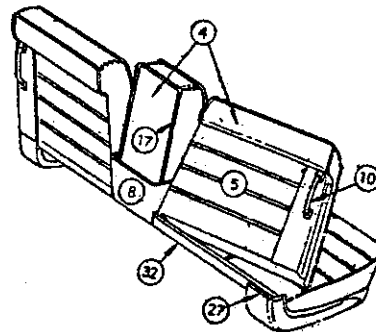
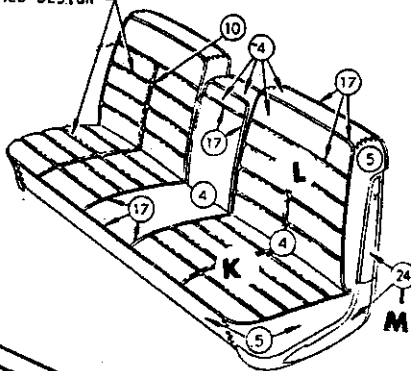

FRONT SEAT ARM REST

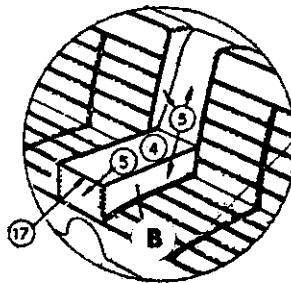

REAR SEAT-ARM REST

DISTRIBUTION OF MATERIAL

- 4 GENUINE LEATHER
- 5 IMITATION LEATHER
- 6 IMITATION LEATHER
- 7 IMITATION LEATHER
- 8 IMITATION LEATHER
- 9 IMITATION LEATHER
- 10 IMITATION LEATHER
- 15 LACE
- 17 EXTRUDED VINYL
- 18 FLOOR COVERING-FRONT-CARPET
- 19 FLOOR COVERING-REAR-CARPET
- 20 FLOOR COVERING-LUGG. COMPT. CARPET
- 22 EMBOSSED CARDBOARD
- 23 PAINT
- 24 METAL
- 25 MOULDING
- 26 MYLAR
- 27 MOULDED RESIN
- 28 MOULDED RUBBER
- 30 WOVEN PAPER
- 32 CARPET
- 33 PLASTIC
- 34 PLASTISOL
- 28-AM-22
- 19-C-5
- 19-C-22
- 22-AR-22
- 19A-C-22
- 19B-C-22

Distribution Drawing Legend Page Appears Following Illustration Section

Codes 951, 955, 956, 957

TYM-433

1963 IMPERIAL TY1-M 4 DOOR HARDTOP
LEATHER TRIM

1963 CHRYSLER - T SERIES

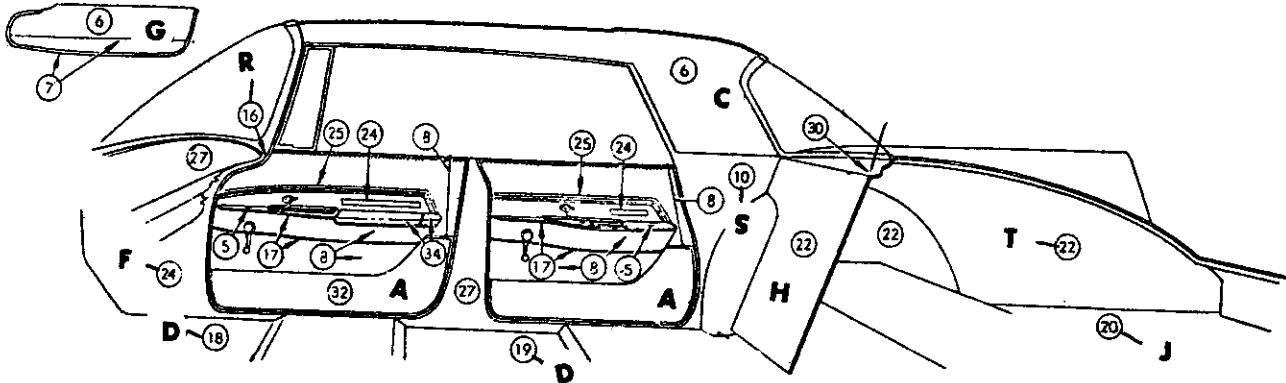

VULCANIZED & STITCHED DESIGN

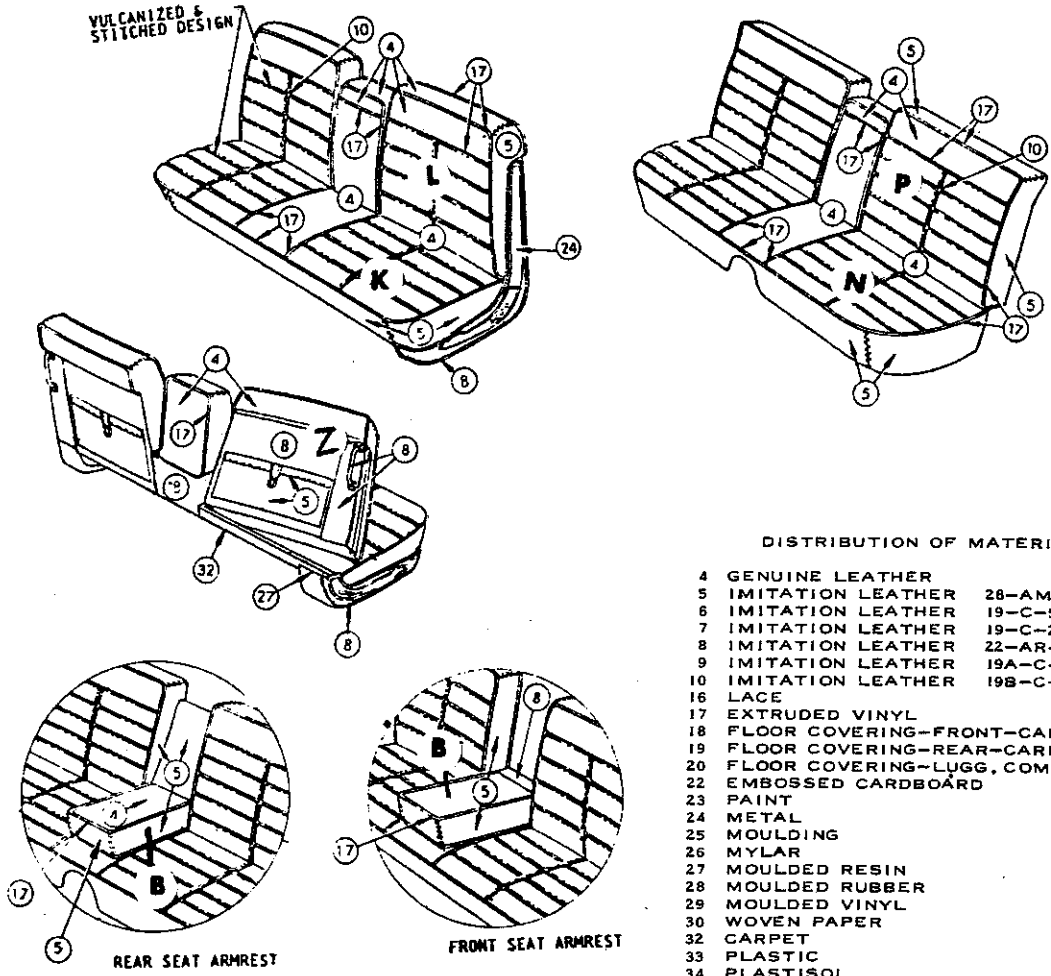

DISTRIBUTION OF MATERIAL

- 4 GENUINE LEATHER
- 5 IMITATION LEATHER
- 6 IMITATION LEATHER
- 7 IMITATION LEATHER
- 8 IMITATION LEATHER
- 9 IMITATION LEATHER
- 10 IMITATION LEATHER
- 16 LACE
- 17 EXTRUDED VINYL
- 18 FLOOR COVERING-FRONT-CARPET
- 19 FLOOR COVERING-REAR-CARPET
- 20 FLOOR COVERING-LUGG. COMPT. CARPET
- 22 EMBOSSED CARDBOARD
- 23 PAINT
- 24 METAL
- 25 MOULDING
- 26 MYLAR
- 27 MOULDED RESIN
- 28 MOULDED RUBBER
- 29 MOULDED VINYL
- 30 WOVEN PAPER
- 32 CARPET
- 33 PLASTIC
- 34 PLASTISOL

Distribution Drawing Legend Page Appears Following Illustration Section

Codes 975, 977

TYH-433

1963 IMPERIAL TY1-H 4 DOOR HARDTOP
LEATHER TRIM

1963 CHRYSLER - T SERIES

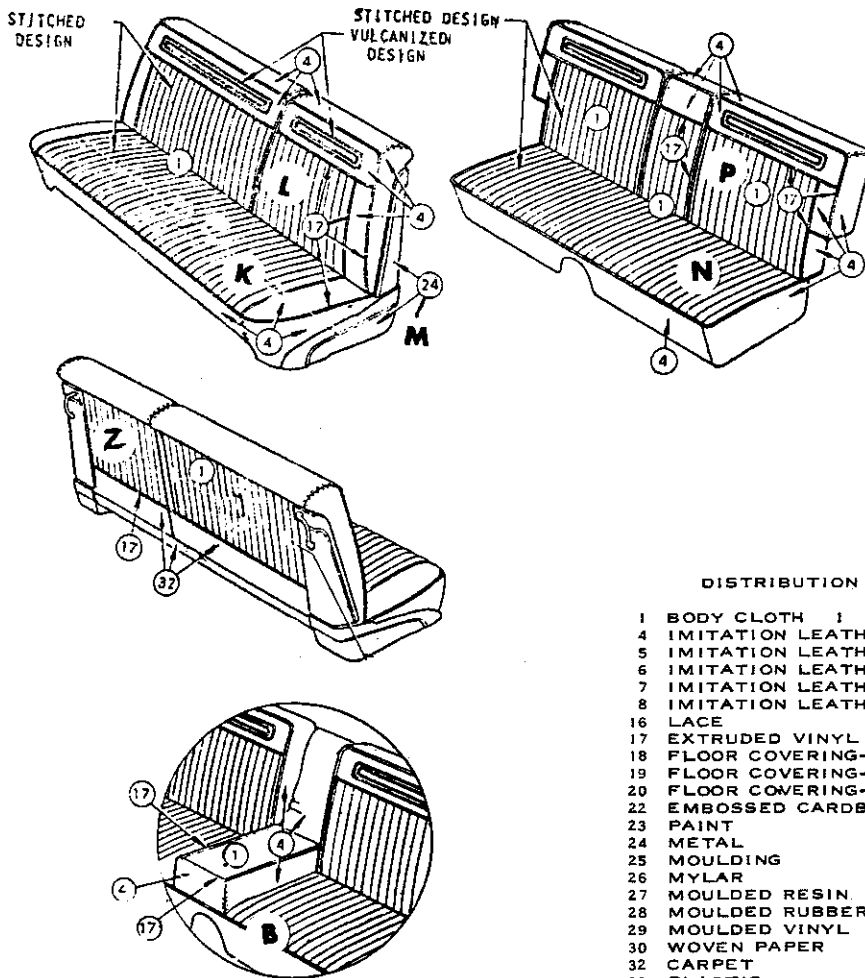
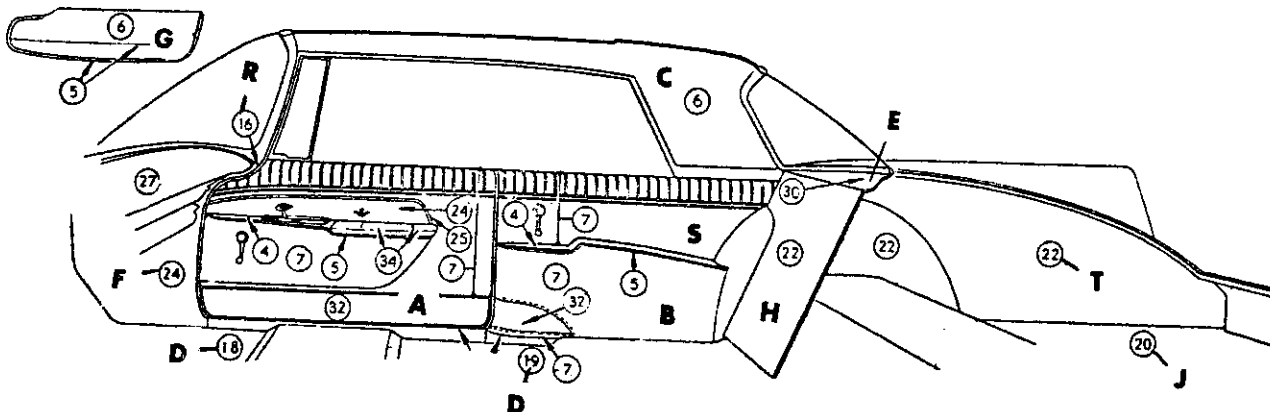

DISTRIBUTION OF MATERIAL

- 1 BODY CLOTH 1
- 4 IMITATION LEATHER 28-AM-22
- 5 IMITATION LEATHER 19-C-22
- 6 IMITATION LEATHER 19-C-5
- 7 IMITATION LEATHER 22-AR-22
- 8 IMITATION LEATHER 19A-C-22
- 16 LACE
- 17 EXTRUDED VINYL
- 18 FLOOR COVERING-FRONT-CARPET
- 19 FLOOR COVERING-REAR-CARPET
- 20 FLOOR COVERING-LUGG. COMPT. CARPET
- 22 EMBOSSED CARDBOARD
- 23 PAINT
- 24 METAL
- 25 MOULDING
- 26 MYLAR
- 27 MOULDED RESIN
- 28 MOULDED RUBBER
- 29 MOULDED VINYL
- 30 WOVEN PAPER
- 32 CARPET
- 33 PLASTIC
- 34 PLASTISOL

Distribution Drawing Legend Page Appears Following Illustration Section

Codes 901, 903, 904, 908, 909

TYL-231

1963 IMPERIAL TY1-L 2 DOOR HARDTOP
CLOTH & IMITATION LEATHER

1963 CHRYSLER - T SERIES

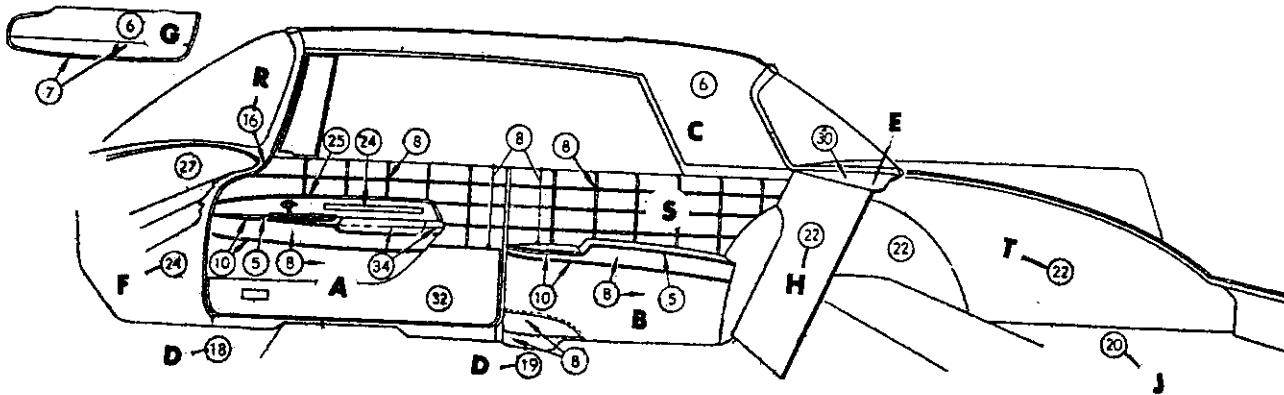

VULCANIZED & STITCHED DESIGN

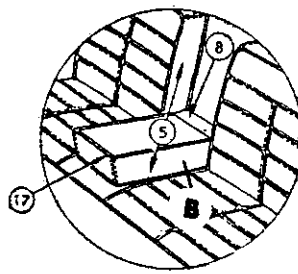
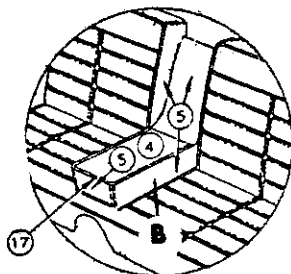
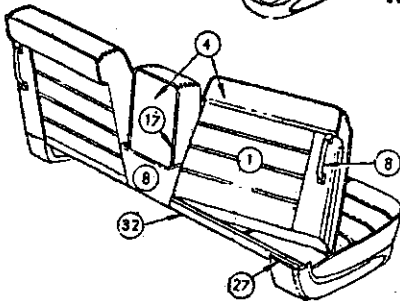
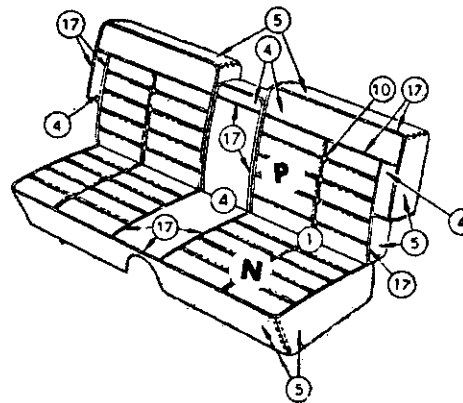
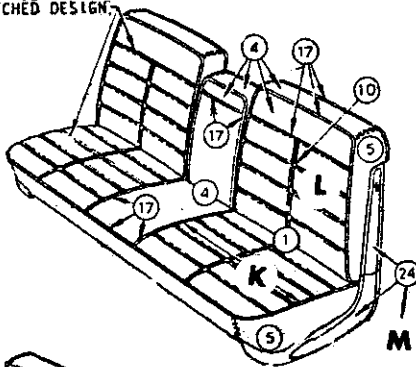

REAR SEAT ARM REST

FRONT SEAT ARM REST

DISTRIBUTION OF MATERIAL

- 1 BODY CLOTH
- 4 GENUINE LEATHER
- 5 IMITATION LEATHER
- 6 IMITATION LEATHER
- 7 IMITATION LEATHER
- 8 IMITATION LEATHER
- 9 IMITATION LEATHER
- 10 IMITATION LEATHER
- 16 LACE
- 17 EXTRUDED VINYL
- 18 FLOOR COVERING-FRONT-CARPET
- 19 FLOOR COVERING-REAR-CARPET
- 20 FLOOR COVERING-LUGG. COMPT. CARPET
- 22 EMBOSSED CARDBOARD
- 23 PAINT
- 24 METAL
- 25 MOULDING
- 26 MYLAR
- 27 MOULDED RESIN
- 28 MOULDED RUBBER
- 29 MOULDED VINYL
- 30 WOVEN PAPER
- 32 CARPET
- 33 PLASTIC
- 34 PLASTISOL

Distribution Drawing Legend Page Appears Following Illustration Section

Codes 921, 923, 924, 925, 928, 929

TYM-235

1963 IMPERIAL TY1-M 2 DOOR HARDTOP
CLOTH & LEATHER TRIM

1963 CHRYSLER - T SERIES

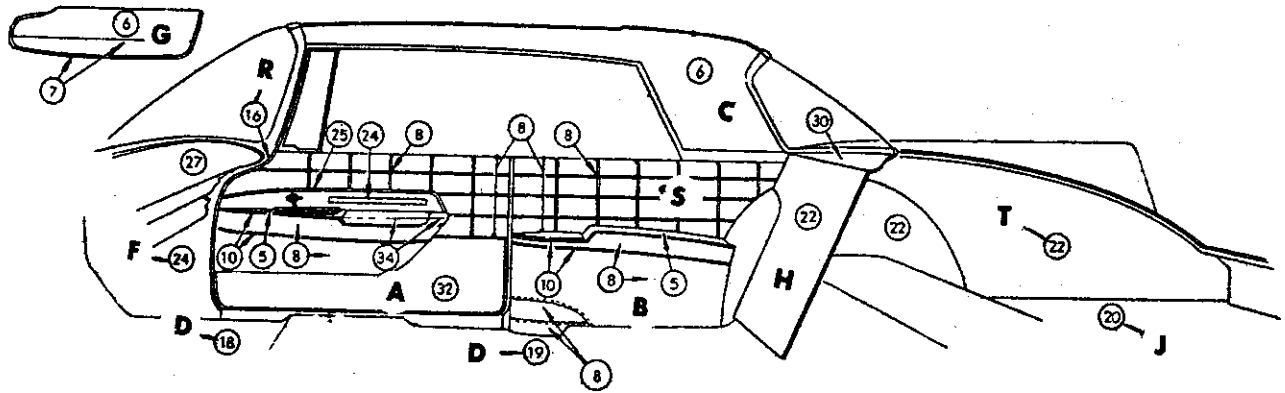

VULCANIZED & STITCHED DESIGN

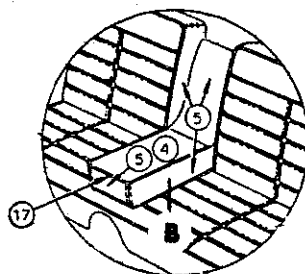
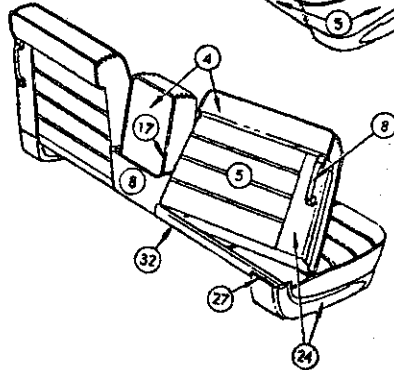
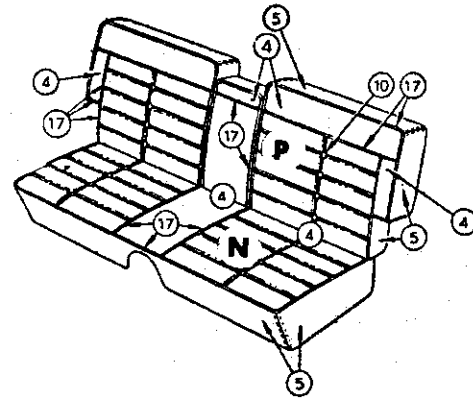
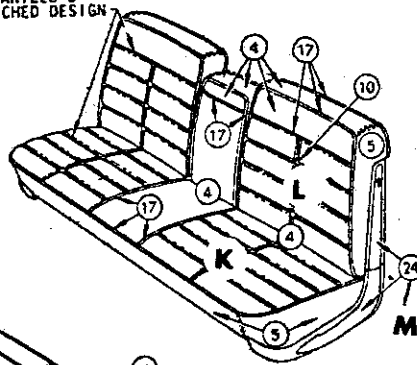

REAR SEAT ARM REST

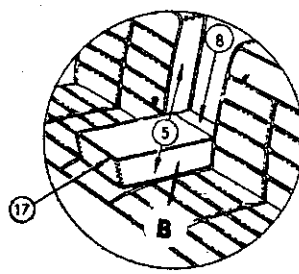

FRONT SEAT ARM REST

DISTRIBUTION OF MATERIAL

- 4 GENUINE LEATHER
- 5 IMITATION LEATHER
- 6 IMITATION LEATHER
- 7 IMITATION LEATHER
- 8 IMITATION LEATHER
- 9 IMITATION LEATHER
- 10 IMITATION LEATHER
- 16 LACE
- 17 EXTRUDED VINYL
- 18 FLOOR COVERING-FRONT-CARPET
- 19 FLOOR COVERING-REAR-CARPET
- 20 FLOOR COVERING-LUGG. COMPT. CARPET
- 22 EMBOSSED CARDBOARD
- 24 METAL
- 25 MOULDING
- 26 MYLAR
- 27 MOULDED RESIN
- 28 MOULDED RUBBER
- 29 MOULDED VINYL
- 30 WOVEN PAPER
- 32 CARPET
- 33 PLASTIC
- 34 PLASTISOL

Distribution Drawing Legend Page Appears Following Illustration Section

Codes 951, 955, 956, 957

TYM-233

1963 IMPERIAL TY1-M 2 DOOR HARDTOP
LEATHER TRIM

1963 IMPERIAL - T SERIES

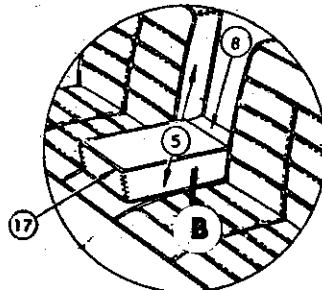
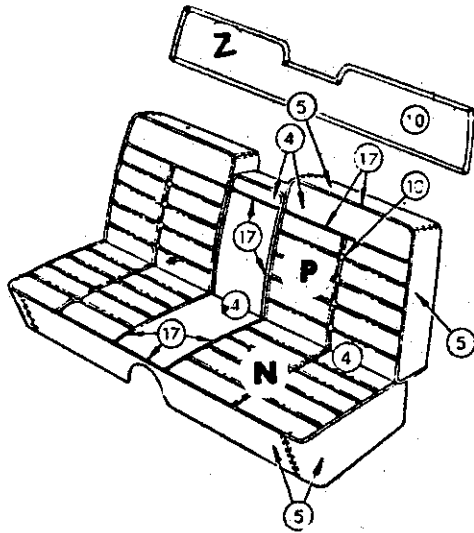
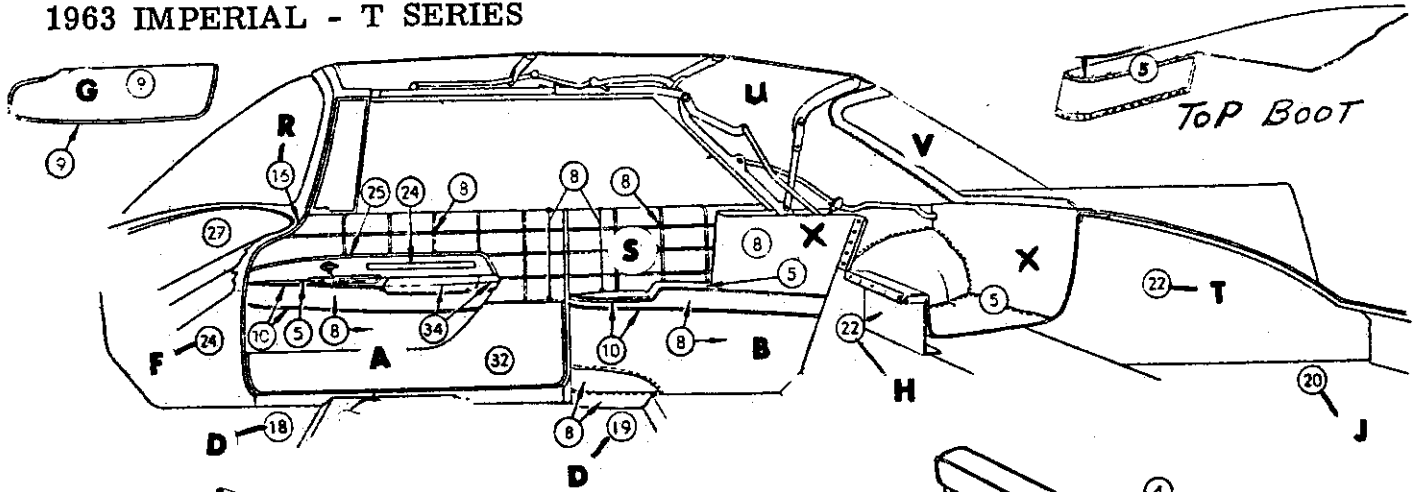

FRONT SEAT ARM REST

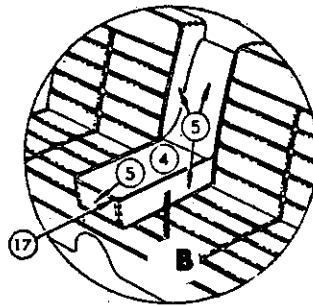
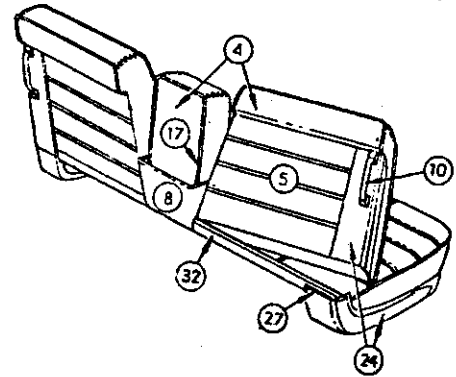

REAR SEAT ARM REST

VULCANIZED & STITCHED DESIGN

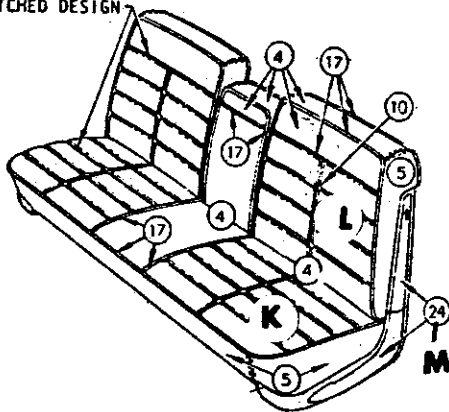

DISTRIBUTION OF MATERIAL

- 4 GENUINE LEATHER
- 5 IMITATION LEATHER 28-AM-22
- 8 IMITATION LEATHER 22-AR-22
- 9 IMITATION LEATHER 19A-C-22
- 10 IMITATION LEATHER 19B-C-22
- 16 LACE
- 17 EXTRUDED VINYL
- 18 FLOOR COVERING-FRONT CARPET
- 19 FLOOR COVERING-REAR CARPET
- 20 FLOOR COVERING-LUGG. COMPT. CARPET
- 22 EMBOSSED CARDBOARD
- 23 PAINT
- 24 METAL
- 25 MOULDING
- 26 MYLAR
- 27 MOULDED RESIN
- 28 MOULDED RUBBER
- 29 MOULDED VINYL
- 32 CARPET
- 33 PLASTIC
- 34 PLASTISOL

Distribution Drawing Legend Page Appears Following Illustration Section

Codes 951, 955, 956, 957

TYM-273

1963 IMPERIAL TY1-M CONVERTIBLE COUPE
LEATHER TRIM

1963 CHRYSLER - T SERIES

Distribution Drawing Legend

See Illustrations For Letter Identification

Letter	Description	Code
A	Panel, Door Trim	23-92-5
B	Arm Rest, Door, Front	23-76-3
	Center, Front Seat	23-76-34
	Door, Rear	23-76-59
	Quarter Panel	23-76-66
C	Headlining	23-86-3
D	Floor Cover, Front, Carpet	23-79-3
	Rubber	23-20-8
	Rear, Carpet	23-79-33
	Rubber	23-20-41
E	Panel, Shelf Trim	23-102-3
F	Panel, Cowl Trim	23-91-6
G	Panel, Visor	23-103-3
H	Panel, Luggage Compartment, Front	23-96-3
J	Cover, Luggage Compartment Floor	23-20-29
K	Cover, Front Seat Cushion	23-108-5
L	Cover, Front Seat Back	23-108-16
M	Cover, Front Seat Hinge	23-108-84
N	Cover, Rear Seat Cushion	23-109-36
P	Cover, Rear Seat Back	23-109-4
Q	Cover, Rear Seat Cushion Bottom Panel	23-109-40
R	Weathercord, Door	23-113-2
	Hinge Pillar	23-113-25
	Lock Pillar	23-113-30
S	Panel, Quarter Trim	23-101-3
T	Cover, Wheelhouse	23-96-8
U	Top Deck and Side Quarter	23-112-108
V	Curtain, Folding Top Back	23-112-45
W	Cover, Center Pillar	23-99-4
X	Well, Pocket Panel, Pocket Panel Cover, Pocket Shelf Panel, Folding Top	23-112-153
Y	Cover, Tailgate Inside Panel	23-79-79
Z	Cover, Rear Seat Back Panel	23-109-5
	Cover, Front Seat Back Panel	23-108-32

BODY CODE	COLUMN LEGEND	
NEWPORT (TC1-L)		
812 (23)	2 D. Hard Top	
813 (41)	4 D. Sedan	
814 (43)	4 D. Hard Top	
815 (27)	Convertible	
858 (46A)	Suburban (6 Pass.)	
859 (46B)	Suburban (9 Pass.)	
893 (41)	4 D. Sedan (Police)	
898 (45A)	Suburban (6 Pass.) (Police)	
NEWPORT (300) (TC2-M)		
822 (23)	2 D. Hard Top	
824 (43)	4 D. Hard Top	
825 (27)	Convertible	
NEWPORT (300) (TC2-M) (PACE CAR)		
802 (23)	2 D. Hard Top	
805 (27)	Convertible	
NEW YORKER (300-J) (TC2-M)		
842 (23)	2 D. Hard Top	
NEW YORKER (TC3-H)		
833 (41)	4 D. Sedan	
834 (43)	4 D. Hard Top	
878 (46)	Suburban (6 Pass.)	
879 (46)	Suburban (9 Pass.)	
884 (41)	4 D. Limousine	
884 (43)	2 D. Hard Top	
NEW YORKER (LUXURY) (TC3-H)		
IMPERIAL (TY1-L)		
912 (23)	2 D. Hard Top	
914 (43)	4 D. Hard Top	
CROWN IMPERIAL (TY1-M)		
922 (23)	2 D. Hard Top	
924 (43)	4 D. Hard Top	
925 (27)	Convertible	
LE BARON (TY1-H)		
934 (43)	4 D. Hard Top	
CONVERTIBLE TOP COLOR LEGEND		
6 Black	7 White	9 Special
STARTING SERIAL NUMBERS		
	Detroit Built	
TC1-L	(Newport)	8133-100001
TC1-L	(Newport Suburban)	8533-100001
TC2-M	(300)	8233-100001
TC2-M	(300) (Pace Car)	8033-100001
TC2-M	(C300-H)	8433-100001
TC3-H	(New Yorker)	8333-100001
TC3-H	(New Yorker Suburban)	8733-100001
TY1-L	(Imperial Custom)	9133-100001
TY1-M	(Imperial Crown)	9233-100001
TY1-H	(Imperial LeBaron)	9333-100001

★ Indicates use as required.

☐ Indicates parts not listed in any previous parts book.

Jan. 3, 1964 Supersedes Jan. 25, 1963.

Page IT-188

Printed in U.S.A.

Prices and specifications subject to change without notice.

Right and left part numbers are on same line,
first number is right, second number is left.

* Indicates change or addition.

TRIM CODE	MODEL	MATERIAL			COLOR	SED.	SP. 4D.	SUB.	SP. CL. CP.	CV. CP.
		Cloth	Vinyl	Leather						
101	C1-L	★	★	-	Blue	★	-	-	-	-
102	C1-L	★	★	-	Green	★	-	-	-	-
103	C1-L	★	★	-	Tan	★	-	-	-	-
105	C1-L	★	★	-	Claret	★	-	-	-	-
108	C1-L	★	★	-	Turquoise	★	-	-	-	-
104	C1-L - Police	★	★	-	Gray	★	-	-	-	-
204	C1-L - Police	-	★	-	Gray	★	-	-	-	-
111	C1-L	-	★	-	Blue	-	★	-	★	-
112	C1-L	-	★	-	Green	-	★	-	★	-
113	C1-L	-	★	-	Tan	-	★	-	★	-
115	C1-L	-	★	-	Claret	-	★	-	★	-
201	C1-L	-	★	-	Blue	-	★	-	★	★
203	C1-L	-	★	-	Tan	-	-	★	★	★
205	C1-L	-	★	-	Claret	-	-	★	★	★
206	C1-L	-	★	-	Black	-	★	★	★	★
208	C1-L	-	★	-	Turquoise	-	★	-	★	★
121	C2-M	★	★	-	Blue	-	★	-	-	-
123	C2-M	★	★	-	Tan	-	★	-	-	-
125	C2-M	★	★	-	Claret	-	★	-	-	-
126	C2-M	★	★	-	Black & Alabaster	-	★	-	-	-
221	C2-M	-	★	-	Blue	-	★	-	★	★
223	C2-M	-	★	-	Tan	-	★	-	★	★
225	C2-M	-	★	-	Claret	-	★	-	★	★
227	C2-M	-	★	-	Alabaster	-	★	-	★	★
228	C2-M	-	★	-	Turquoise	-	★	-	★	★
245	C2-M	-	★	-	Claret	-	★	-	★	★
141	C3-H	★	★	-	Blue	★	★	-	-	-
142	C3-H	★	★	-	Green	★	★	-	-	-
143	C3-H	★	★	-	Tan	★	★	-	-	-
144	C3-H	★	★	-	Gray	★	★	-	-	-
148	C3-H	★	★	-	Turquoise	★	★	-	-	-
151	C3-H - Luxury	★	-	★	Blue	-	★	-	-	-
153	C3-H - Luxury	★	-	★	Beige	-	★	-	-	-
251	C3-H - Luxury	-	-	★	Blue	-	★	-	-	-
253	C3-H - Luxury	-	-	★	Beige	-	★	-	-	-
231	C3-H	-	★	-	Blue	-	★	★	-	-
233	C3-H	-	★	-	Tan	-	-	★	-	-
235	C3-H	-	★	-	Claret	-	★	★	-	-
236	C3-H	-	★	-	Black	-	★	★	-	-
901	Y1-L	★	★	-	Blue	-	★	-	★	-
903	Y1-L	★	★	-	Tan	-	★	-	★	-
904	Y1-L	★	★	-	Gray	-	★	-	★	-
908	Y1-L	★	★	-	Turquoise	-	★	-	★	-
909	Y1-L	★	★	-	Gold	-	★	-	★	-
921	Y1-M	★	-	★	Blue	-	★	-	★	-
923	Y1-M	★	-	★	Tan	-	★	-	★	-
924	Y1-M	★	-	★	Gray	-	★	-	★	-
925	Y1-M	★	-	★	Red	-	★	-	★	-
928	Y1-M	★	-	★	Turquoise	-	★	-	★	-
929, 939	Y1-M	★	-	★	Gold	-	★	-	★	-
951	Y1-M	-	-	★	Blue	-	★	-	★	★
955	Y1-M	-	-	★	Red	-	★	-	★	★
956	Y1-M	-	-	★	Black	-	★	-	★	★
957	Y1-M	-	-	★	Alabaster	-	★	-	★	★
941	Y1-H	★	-	★	Blue	-	★	-	-	-
943	Y1-H	★	-	★	Tan	-	★	-	-	-
944	Y1-H	★	-	★	Gray	-	★	-	-	-
949	Y1-H	★	-	★	Gold	-	★	-	-	-
975	Y1-H	-	-	★	Red	-	★	-	-	-
976	Y1-H	-	-	★	Black	-	★	-	-	-
977	Y1-H	-	-	★	White	-	★	-	-	-

★ Indicates use as required.
 ☐ Indicates parts not listed in any previous parts book.
 Right and left part numbers are on same line,
 first number is right, second number is left.
 * Indicates change or addition.

1963 PASSENGER CAR PARTS CATALOG

INTERIOR TRIM

CODE	REMARKS	PER CAR	SED.	SP. 4 D.	SUB.	SP. CL. CP.	CV. CP.
NOTE: RIGHT HAND AND LEFT HAND PARTS LISTED ON THE SAME LINE. Whenever right and left hand parts are identified by consecutive part numbers, they will be listed as in the following example: PANEL, Door Trim 2083 344-5							
Interpreted, this indicates that Panel, right is Part No. 2083 344 and Panel, left is Part No. 2083 345.							
23-70-5	COVER, Wheelhouse 2nd. Seat Back Hinge Bracket C1-L, C3-H (codes 201, 231) (blue) (codes 203, 233) (tan) (codes 205, 235) (red) (codes 206, 236) (black)	1 1 1 1	---- ---- ---- ----	---- ---- ---- ----	2180 202-3 2180 098-9 E2181 370-1 E2028-9 TX8		
23-70-6	COVER, 2nd Seat Back Hinge C1	1	----	----	2094 882-3		
23-70-7	WASHER, 2nd Seat Back Hinge Cover Attaching	2	----	----	*2490 517		
23-71-1	CARPET and FOUNDATION, Floor Console Side C2-M (code 221) Rt. (code 223) Lt. (code 225, 245) Rt. (code 227) Lt. (code 228) Rt. (code 228) Lt. (fastener)	1 1 1 1 1 1 1 16	---- ---- ---- ---- ---- ---- ----	2181 008 2181 013 2181 009 2181 014 2181 010 2181 015 2181 011 2181 016 2181 012 2181 017 975 633	---- ---- ---- ---- ---- ---- ---- ---- ---- ---- ----	2181 008 2181 013 2181 009 2181 014 2181 010 2181 015 2181 011 2181 016 2181 012 2181 017 975 633	2181 008 2181 013 2181 009 2181 014 2181 010 2181 015 2181 011 2181 016 2181 012 2181 017 975 633
23-71-4	RETAINER, Floor Tunnel Console Lid Pad C2-M	1	----	E2490 458	----	E2490 458	E2490 458
23-71-5	PAD, Floor Tunnel Console Trim C2-M (code 221) (blue) (code 223) (tan) (codes 225, 245) (red) (code 227) (alabaster) (code 228) (turquoise)	1 1 1 1 1	---- ---- ---- ---- ----	E2180 866-7 E2180 158-9 E2180 160-1 E2180 164-5 E2180 166-7	---- ---- ---- ---- ----	E2180 866-7 E2180 158-9 E2180 160-1 E2180 164-5 E2180 166-7	E2180 866-7 E2180 158-9 E2180 160-1 E2180 164-5 E2180 166-7
23-76-3	ARM REST, Front Door C1, C2, C3 (codes 101, 111, 201) (blue) (codes 121, 221) (blue) (codes 102, 112) (green) (codes 103, 113, 123, 203, 223, 233) (tan) (codes 105, 115, 125, 205, 225, 245) (red) (codes 106, 208, 228) (turquoise) (codes 126, 127) (alabaster) (codes 104, 204, 206) (black) (code 206) (codes 151, 251) (blue) (codes 153, 253) (beige)	1 1 1 1 1 1 1 1 1 1 1 1 1	2428 970-1 ---- 2428 972-3 2428 974-5 2428 984-5 2428 986-7 ---- 2181 024-5 ---- ---- ----	2428 970-1 2180 856-7 2428 972-3 2428 974-5 2428 984-5 2428 986-7 2428 978-9 2181 024-5 E2428 982-3 2182 154-5 2182 156-7	2428 970-1 ---- ---- 2428 974-5 2428 984-5 2428 986-7 ---- 2181 024-5 E2428 982-3 2181 024-5 E2428 982-3 2182 154-5 2182 156-7	2428 970-1 2180 856-7 2428 972-3 2428 974-5 2428 984-5 2428 986-7 2428 978-9 2181 024-5 E2428 982-3 2181 024-5 E2428 982-3 2182 154-5 2182 156-7	2428 970-1 2180 856-7 2428 972-3 2428 974-5 2428 984-5 2428 986-7 2428 978-9 2181 024-5 E2428 982-3 2181 024-5 E2428 982-3 2182 154-5 2182 156-7

★ Indicates use as required.

E Indicates parts not listed in any previous parts book.

Jan. 3, 1964 Supersedes Jan. 25, 1963.

Printed in U.S.A.

Prices and specifications subject to change without notice.

Right and left part numbers are on same line,
first number is right, second number is left.

* Indicates change or addition.

CODE	REMARKS	PER CAR	SED.	SP. 4 D.	SUB.	SP. CL. CP.	CV. CP.
23-76-3	ARM REST, Front Door - Cont'd C3-H (codes 141, 231) (code 142) (codes 143, 233) (code 144) (code 148) (code 235) (code 236)	1 1 1 1 1 1 1	⊠2182 298-9 ⊠2182 300-1 ⊠2182 302-3 ⊠2182 304-5 ⊠2182 306-7 ---- ----	⊠2182 298-9 ⊠2182 300-1 ⊠2182 302-3 ⊠2182 304-5 ⊠2182 306-7 ⊠2182 308-9 ⊠2182 310-1	⊠2182 298-9 ⊠2182 302-3 ⊠2182 304-5 ⊠2182 308-9 ⊠2182 310-1		
23-76-4	LID, Front Door Arm Rest Storage Compartment Y1-L, Y1-M, Y1-H (codes 901, 921, 941, 951) (blue) (codes 902, 923, 943) (tan) (codes 904, 924, 944) (gray) (codes 925, 955, 975) (red) (codes 908, 928) (turquoise) (codes 909, 929, 939, 949) (gold) (code 956) (charcoal) (codes 957, 976, 977) (alabaster) (attaching screw)(lid to hinge)	1 1 1 1 1 6	---- ---- ---- ---- ---- ----	2180 470-1 2180 472-3 2180 474-5 2180 480-1 2180 476-7 2180 478-9 2180 482-3 2180 484-5 9418 297	---- ---- ---- ---- ---- ----	2180 470-1 2180 472-3 2180 474-5 2180 480-1 2180 476-7 2180 478-9 2180 482-3 2180 484-5 9418 297	⊠2180 470-1 2180 480-1 2180 482-3 2180 484-5 9418 297
23-76-5	PULL, Door Arm Rest C3-H Y1 (cup)	1 1	2080 114-5 ----	2080 114-5 2085 660-1	*2080 114-5 ----	2085 660-1	2085 660-1
23-76-6	BOX, Front Door Arm Rest Storage Compartment Y1 (gray)	2	----	2180 502	----	2180 502	2180 502
23-76-7	BRACKET, Door Arm Rest Support C3-H Screw	4 ★	*2086 210 274 888	*2086 210 274 888	*2086 210 274 888		
23-76-11	PAD, Front Door Arm Rest Y1-L, Y1-M, Y1-H (codes 901, 921, 941, 951) (blue) (codes 903, 923, 943) (tan) (codes 904, 924, 944) (gray) (codes 925, 955, 975) (red) (codes 908, 928) (turquoise) (codes 909, 929, 939, 949) (gold) (code 956) (charcoal) (codes 957, 976, 977) (alabaster) Rt. Lt.	1 1 1 1 1 1 1 1 1 1	---- ---- ---- ---- ---- ---- ---- ---- ---- ----	2180 486-7 2180 488-9 2180 490-1 2180 496-7 2180 492-3 2180 494-5 2180 498-9 2180 500 2180 501	---- ---- ---- ---- ---- ---- ---- ---- ---- ----	2180 486-7 2180 488-9 2180 490-1 2180 496-7 2180 492-3 2180 494-5 2180 498-9 2180 500 2180 501	2180 486-7 2180 496-7 2180 494-5 2180 498-9 2180 500 2180 501
23-76-16	NUT, Arm Rest Support Bracket C3-H (door) (quarter arm rest to quarter panel)	4 4	*1280 134 ----	*1280 134 ----	*1280 134 ----	*1280 134 1280 134	*1280 134

★ Indicates use as required.
⊠ Indicates parts not listed in any previous parts book.
Right and left part numbers are on same line,
first number is right, second number is left.
* Indicates change or addition.

Printed in U.S.A.
Prices and specifications subject to change without notice.
Jan. 3, 1964 Supersedes Jan. 25, 1963.

1963 PASSENGER CAR PARTS CATALOG

INTERIOR TRIM

CODE	REMARKS	PER CAR	SED.	SP. 4 D.	SUB.	SP. CL. CP.	CV. CP.
23-76-17	HINGE, Front Seat Back Center Arm Rest C3-H	1	2270 274-5	2270 274-5			
	(pin retaining ring)	2	----	1626 749			
	(rivet)	2	----	6024 289			
	(washer)	2	----	6024 290			
	(screw w/washer) (hinge to lid)	4	----	6024 281			
	Y1 (door arm rest)	2	----	*2292 716	----	*2292 716	*2292 716
23-76-18	ARM REST, Front Seat Back Center C2-M						
	(code 221)	1	----	2134 812	----	2134 812	2134 812
	(code 223)	1	----	2134 291	----	2134 291	2134 291
	(code 225)	1	----	2133 632	----	2133 632	2133 632
	(code 227)	1	----	2133 634	----	2133 634	2133 634
	(code 228)	1	----	2133 635	----	2133 635	2133 635
	(code 245)	1	----	2134 645	----	2134 645	2134 645
	C3-H						
	(code 231)	1	----	2134 871	2134 871		
	(code 233)	1	----	2133 631	2133 631		
	(code 235)	1	----	2133 632	2133 632		
	(code 236)	1	----	2133 633	2133 633		
	(code 141)	1	2134 550	2134 550			
	(code 142)	1	2134 551	2134 551			
	(code 143)	1	2134 552	2134 552			
	(code 144)	1	2134 553	2134 553			
	(code 148)	1	2134 554	2134 554			
	(code 151)	1	----	B2434 268			
	(code 251)	1	----	B2434 274			
	(code 153)	1	----	B2434 299			
	(code 253)	1	----	B2434 275			
	(rivet)	2	----	B6024 289			
	Washer (hinge to bracket)	2	----	B6024 290			
	Y1-M (short)						
	(code 921)	1	----	2430 072	----	2430 072	
	(code 923)	1	----	2430 073	----	2430 073	
	(code 924)	1	----	2430 074	----	2430 074	
	(code 925)	1	----	2430 075	----	2430 075	
	(code 928)	1	----	2430 078	----	2430 078	
	(codes 929, 939)	1	----	2430 079	----	2430 079	
	(code 951)	1	----	2430 072	----	2430 072	2430 072
	(code 955)	1	----	2430 075	----	2430 075	2430 075
	(code 956)	1	----	2430 076	----	2430 076	2430 076
	(code 957)	1	----	2430 077	----	2430 077	2430 077
	Y1-M (long)						
	(code 921)	1	----	2430 456			
	(code 923)	1	----	2430 457			
	(code 924)	1	----	2430 458			
	(code 925)	1	----	2430 459			
	(code 928)	1	----	2430 462			
	(codes 929, 939)	1	----	2430 463			
	(code 951)	1	----	2430 456			
	(code 955)	1	----	2430 459			
	(code 956)	1	----	2430 460			
	(code 957)	1	----	2430 461			
	Nut (frame)	★	6010 006	6010 006			
	Screw & Washer (to bracket & board)	★	6023 543	6023 543			
	Bolt (back to cushion)	1	----	*6024 148			

★ Indicates use as required.

⊠ Indicates parts not listed in any previous parts book.
Jan. 3, 1964 Supersedes Dec. 14, 1962.

Printed in U.S.A.
Prices and specifications subject to change without notice.
Right and left part numbers are on same line,
first number is right, second number is left.

* Indicates change or addition.

CODE	REMARKS	PER CAR	SED.	SP. 4 D.	SUB.	SP. CL. CP.	CV. CP.	
23-76-18	ARM REST, Front Seat Back Center - Cont'd Y1-H (short)							
	(code 941)	1	----	2430 084				
	(code 943)	1	----	2430 085				
	(code 944)	1	----	2430 086				
	(code 949)	1	----	2430 087				
	(code 975)	1	----	2430 075				
	(code 976)	1	----	2430 076				
	(code 977)	1	----	2430 077				
	Y1-H (long)							
	(code 941)	1	----	2430 436				
	(code 943)	1	----	2430 437				
	(code 944)	1	----	2430 438				
	(code 949)	1	----	2430 439				
	(code 975)	1	----	2430 459				
(code 976)	1	----	2430 460					
(code 977)	1	----	2430 461					
23-76-19	FLAP, Front Seat Back Center Arm Rest C3-H							
	(code 141)	1	2134 560	2134 560				
	(code 142)	1	2134 561	2134 561				
	(code 143)	1	2134 562	2134 562				
	(code 144)	1	2134 563	2134 563				
	(code 148)	1	2134 564	2134 564				
23-76-26	SPRING, Front Door Arm Rest Storage Compartment Lid Hinge Y1	2	----	2419 556	----	2419 556	2419 556	
23-76-27	RETAINER, Front Seat Center Arm Rest Frame Hook C2, C3, Y1	1	1918 568	1918 568	1918 568	1918 568	1918 568	
	23-76-28	LOCK BAR, Front Seat Center Arm Rest Frame C3H, Y1	1	----	2410 033	----	2410 033	2410 033
		23-76-31	LINER, Front Seat Center Arm Rest Lid C3-H					
			(codes 151,251)	1	----	2182 179		
			(codes 153,253)	1	----	2182 180		
Screw (liner attaching)	2	----	⊕9418 246					
23-76-34	COVER, Front Seat Back Center Arm Rest C3-H							
	(code 141)	1	2134 555	2134 555				
	(code 142)	1	2134 556	2134 556				
	(code 143)	1	2134 557	2134 557				
	(code 144)	1	2134 558	2134 558				
	(code 148)	1	2134 559	2134 559				
	C3-H (body cloth)							
	(code 141)	1	⊕2434 296	⊕2434 296				
	(code 143)	1	⊕2434 297	⊕2434 297				
	(code 148)	1	⊕2434 298	⊕2434 298				
	(code 221)	1	----	2134 813	----	2134 813	2134 813	
(code 223)	1	----	2134 292	----	2134 292	2134 292		
(code 231)	1	----	2134 872	2134 872				
(code 233)	1	----	----	2133 636				

★ Indicates use as required.
 ⊕ Indicates parts not listed in any previous parts book.
 Right and left part numbers are on same line,
 first number is right, second number is left.
 * Indicates change or addition.

Printed in U.S.A.
 Prices and specifications subject to change without notice.
 Jan. 3, 1964 Supersedes Jan. 25, 1963.

1963 PASSENGER CAR PARTS CATALOG

INTERIOR TRIM

CODE	REMARKS	PER CAR	SED.	SP. 4 D.	SUB.	SP. CL. CP.	CV. CP.
23-76-34	COVER, Front Seat Back Center Arm Rest - Cont'd C3-H						
	(codes 225, 235)	1	----	2133 637	2133 637	2133 637	2133 637
	(code 236)	1	----	2133 638	2133 638	2133 638	2133 638
	(code 227)	1	----	2133 639	----	2133 639	2133 639
	(code 228)	1	----	2133 640	----	2133 640	2133 640
	(code 245)	1	----	2134 646	----	2134 646	2134 646
	(storage compt. type arm rest)						
	(code 151)	1	----	2434 016			
	(code 153)	1	----	2434 017			
	(code 251)	1	----	2434 058			
	(code 253)	1	----	2434 059			
	(liner and cover)						
	(codes 151, 251) (blue)	1	----	⊠2182 278			
	(luxury model, full arm rest type)						
	(code 151)	1	----	2434 270			
	(code 153)	1	----	2434 271			
	(code 251)	1	----	2434 276			
	(code 253)	1	----	2434 277			
	(lid cover)						
	(codes 151, 251)	2	----	2434 222			
	(codes 153, 253)	2	----	2434 223			
	Y1-M (for short arm rest)						
	(code 921)	1	----	2430 064	----	2430 064	
	(code 923)	1	----	2430 065	----	2430 065	
	(code 924)	1	----	2430 066	----	2430 066	
	(code 925)	1	----	2430 067	----	2430 067	
	(code 928)	1	----	2430 070	----	2430 070	
	(code 929)	1	----	2430 071	----	2430 071	
	(code 951)	1	----	2430 064	----	2430 064	2430 064
	(code 955)	1	----	2430 067	----	2430 067	2430 067
	(code 956)	1	----	2430 068	----	2430 068	2430 068
	(code 957)	1	----	2430 069	----	2430 069	2430 069
	Y1-M (for long arm rest)						
	(code 921)	1	----	2430 448			
	(code 923)	1	----	2430 449			
	(code 924)	1	----	2430 450			
	(code 925)	1	----	2430 451			
	(code 928)	1	----	2430 454			
	(codes 929, 939)	1	----	2430 455			
	(code 951)	1	----	2430 448			
	(code 955)	1	----	2430 451			
	(code 956)	1	----	2430 452			
	(code 957)	1	----	2430 453			
	Y1-H (for short arm rest)						
	(code 941)	1	----	2430 080			
	(code 943)	1	----	2430 081			
	(code 944)	1	----	2430 082			
	(code 949)	1	----	2430 083			
	(code 975)	1	----	2430 067			
	(code 976)	1	----	2430 068			
	(code 977)	1	----	2430 069			
	Y1-H (for long arm rest)						
	(code 941)	1	----	2430 432			
	(code 943)	1	----	2430 433			
	(code 944)	1	----	2430 434			
	(code 949)	1	----	2430 435			
	(code 975)	1	----	2430 451			
	(code 976)	1	----	2430 452			
	(code 977)	1	----	2430 433			

★ Indicates use as required.

⊠ Indicates parts not listed in any previous parts book.
Jan. 3, 1964 Supersedes Jan. 25, 1963.

Printed in U.S.A.

Prices and specifications subject to change without notice.
Right and left part numbers are on same line,
first number is right, second number is left.

* Indicates change or addition.

CODE	REMARKS	PER CAR	SED.	SP. 4 D.	SUB.	SP. CL. CP.	CV. CP.	
23-76-35	PANEL, Front Seat Back Center Arm Rest Lower C3-H							
	(codes 151, 251)	1	----	2434 142				
	(codes 153, 253)	1	----	2434 143				
	Y1							
	(codes 921, 941, 951)	1	----	2430 096	----	2430 096	2430 096	
	(codes 923, 943)	1	----	2430 097	----	2430 097	2430 097	
	(codes 924, 944)	1	----	2430 098	----	2430 098	2430 098	
	(codes 925, 955, 975)	1	----	2430 099	----	2430 099	2430 099	
	(codes 956, 976)	1	----	2430 100	----	2430 100	2430 100	
	(codes 957, 977)	1	----	2430 101	----	2430 101	2430 101	
	(code 928)	1	----	2430 102	----	2430 102	2430 102	
	(codes 929, 939, 949)	1	----	2430 103	----	2430 103	----	
	23-76-37	COVER, Front Seat Back Center Arm Rest Lower Panel C3-H						
		(codes 151, 251)	1	----	2434 144			
(codes 153, 253)		1	----	2434 145				
Y1								
(codes 921, 941, 951)		1	----	2430 088	----	2430 088	2430 088	
(codes 923, 943)		1	----	2430 089	----	2430 089	2430 089	
(codes 924, 944)		1	----	2430 090	----	2430 090	2430 090	
(codes 925, 955, 975)		1	----	2430 091	----	2430 091	2430 091	
(code 928)		1	----	2430 094	----	2430 094	2430 094	
(codes 929, 939, 949)		1	----	2430 095	----	2430 095	2430 095	
(code 956)		1	----	2430 092	----	2430 092	2430 092	
(codes 957, 977)		1	----	2430 093	----	2430 093	2430 093	
23-76-40		ARM REST, Rear Seat Back Center C3-H						
		(code 141)	1	2133 980	2133 980			
	(code 142)	1	2133 981	2133 981				
	(code 143)	1	2133 982	2133 982				
	(code 144)	1	2133 983	2133 983				
	(code 148)	1	2133 984	2133 984				
	(code 151)	1	----	2434 030				
	(code 251)	1	----	2434 072				
	(code 153)	1	----	2434 031				
	(code 253)	1	----	2434 073				
	(code 231)	1	----	2134 880				
	(code 235)	1	----	2134 128				
	(code 236)	1	----	2134 129				
	Y1-L (short)							
	(code 901)	1	----	2295 806	----	2295 806		
	(code 903)	1	----	2295 807	----	2295 807		
	(code 904)	1	----	2295 808	----	2295 808		
	(code 908)	1	----	2295 809	----	2295 809		
	Y1-L (long)							
	(code 901)	1	----	2430 403				
	(code 903)	1	----	2430 404				
	(code 904)	1	----	2430 405				
	(code 908)	1	----	2430 406				
	(code 909)	1	----	2430 407				
	Y1-M (short)							
	(code 921)	1	----	2295 751	----	2295 751		
	(code 923)	1	----	2295 752	----	2295 752		
	(code 924)	1	----	2295 753	----	2295 753		
(code 925)	1	----	2295 754	----	2295 754			
(code 928)	1	----	2295 757	----	2295 757			
(codes 929, 939)	1	----	2295 758	----	2295 758			

★ Indicates use as required.
 ☐ Indicates parts not listed in any previous parts book.
 Right and left part numbers are on same line,
 first number is right, second number is left.
 * Indicates change or addition.

1963 PASSENGER CAR PARTS CATALOG

INTERIOR TRIM

CODE	REMARKS	PER CAR	SED.	SP. 4 D.	SUB.	SP. CL. CP.	CV. CP.
23-76-40	ARM REST, Rear Seat Back Center - Cont'd Y1-M (short)						
	(code 951)	1	----	2295 751	----	2295 751	2430 174
	(code 955)	1	----	2295 754	----	2295 754	2430 175
	(code 956)	1	----	2295 755	----	2295 755	2430 176
	(code 957)	1	----	2295 756	----	2295 756	2430 177
	Y1-M (long)						
	(code 921)	1	----	2430 424			
	(code 923)	1	----	2430 425			
	(code 924)	1	----	2430 426			
	(code 925)	1	----	2430 427			
	(code 928)	1	----	2430 430			
	(code 929)	1	----	2430 431			
	(code 951)	1	----	2430 424			
	(code 955)	1	----	2430 427			
	(code 956)	1	----	2430 428			
	(code 957)	1	----	2430 429			
	Bolt (frame)	★	* 180 022	* 180 022	----	* 180 022	* 180 022
	Y1-H (short)						
	(code 941)	1	----	2295 773			
	(code 943)	1	----	2295 774			
	(code 944)	1	----	2295 775			
	(code 949)	1	----	2295 776			
	(code 975)	1	----	2295 754			
	(code 976)	1	----	2295 755			
	(code 977)	1	----	2295 756			
	Y1-H (long)						
	(code 941)	1	----	2430 412			
	(code 943)	1	----	2430 413			
	(code 944)	1	----	2430 414			
	(code 949)	1	----	2430 415			
	(code 975)	1	----	2430 427			
	(code 976)	1	----	2430 428			
	(code 977)	1	----	2430 429			
23-76-45	COVER, Rear Seat Back Center Arm Rest C3-H						
	(code 141)	1	2133 985	2133 985			
	(code 142)	1	2133 986	2133 986			
	(code 143)	1	2133 987	2133 987			
	(code 144)	1	2133 988	2133 988			
	(code 148)	1	2133 989	2133 989			
	C3-H (body cloth)						
	(code 141)	1	⊠2434 320	⊠2434 320			
	(code 143)	1	⊠2434 321	⊠2434 321			
	(code 148)	1	⊠2434 322	⊠2434 322			
	(code 151)	1	----	2434 032			
	(code 251)	1	----	2434 074			
	(code 153)	1	----	2434 033			
	(code 253)	1	----	2434 075			
	(code 231)	1	----	2134 881			
	(code 235)	1	----	2134 131			
	(code 236)	1	----	2134 132			
	Y1-L (for short arm rest)						
	(code 901)	1	----	2295 801	----	2295 801	
	(code 903)	1	----	2295 802	----	2295 802	
	(code 904)	1	----	2295 803	----	2295 803	
	(code 908)	1	----	2295 804	----	2295 804	
	(code 909)	1	----	2295 805	----	2295 805	

★ Indicates use as required.

⊠ Indicates parts not listed in any previous parts book.
Jan. 3, 1964 Supersedes Jan. 25, 1963.Printed in U.S.A.
Prices and specifications subject to change without notice.
Right and left part numbers are on same line,
first number is right, second number is left.
* Indicates change or addition.

CODE	REMARKS	PER CAR	SED.	SP. 4 D.	SUB.	SP. CL. CP.	CV. CP.
23-76-45	COVER, Rear Seat Back Center Arm Rest - Cont'd						
	Y1-L (for long arm rest)						
	(code 901)	1	----	2430 398			
	(code 903)	1	----	2430 399			
	(code 904)	1	----	2430 400			
	(code 908)	1	----	2430 401			
	(code 909)	1	----	2430 402			
	Y1-M (for short arm rest)						
	(code 921)	1	----	2295 743	----	2295 743	
	(code 923)	1	----	2295 744	----	2295 744	
	(code 924)	1	----	2295 745	----	2295 745	
	(code 925)	1	----	2295 746	----	2295 746	
	(code 928)	1	----	2295 749	----	2295 749	
	(code 929, 939)	1	----	2295 750	----	2295 750	
	(code 951)	1	----	2295 743	----	2295 743	2430 170
	(code 955)	1	----	2295 746	----	2295 746	2430 171
	(code 956)	1	----	2295 747	----	2295 747	2430 172
	(code 957)	1	----	2295 748	----	2295 748	2430 173
	Y1-M (for long arm rest)						
	(code 921)	1	----	2430 416			
	(code 923)	1	----	2430 417			
	(code 924)	1	----	2430 418			
	(code 925)	1	----	2430 419			
	(code 928)	1	----	2430 422			
	(codes 929, 939)	1	----	2430 423			
	(code 951)	1	----	2430 416			
	(code 955)	1	----	2430 419			
	(code 956)	1	----	2430 420			
	(code 957)	1	----	2430 421			
	Y1-H (for short arm rest)						
	(code 941)	1	----	2295 769			
	(code 943)	1	----	2295 770			
	(code 944)	1	----	2295 771			
	(code 949)	1	----	2295 772			
	(code 975)	1	----	2295 746			
	(code 976)	1	----	2295 747			
	(code 977)	1	----	2295 748			
	Y1-H (for long arm rest)						
	(code 941)	1	----	2430 408			
	(code 943)	1	----	2430 409			
	(code 944)	1	----	2430 410			
	(code 949)	1	----	2430 411			
	(code 975)	1	----	2430 419			
	(code 976)	1	----	2430 420			
	(code 977)	1	----	2430 421			
23-76-53	FLAP, Rear Seat Back Center Arm Rest						
	C3-H						
	(code 141)	1	2133 990	2133 990			
	(code 142)	1	2133 991	2133 991			
	(code 143)	1	2133 992	2133 992			
	(code 144)	1	2133 993	2133 993			
	(code 148)	1	2133 994	2133 994			
	(code 231)	1	----	2134 882			
	(code 235)	1	----	2134 134			
	(code 236)	1	----	2134 135			

★ Indicates use as required.
 ☐ Indicates parts not listed in any previous parts book.
 Right and left part numbers are on same line,
 first number is right, second number is left.
 * Indicates change or addition.

1963 PASSENGER CAR PARTS CATALOG

INTERIOR TRIM

CODE	REMARKS	PER CAR	SED.	SP. 4 D.	SUB.	SP. CL. CP.	CV. CP.
23-76-53	FLAP, Rear Seat Back Center Arm Rest - Cont'd						
	Y1-L						
	(code 901)	1	----	2295 735	----	2295 735	
	(code 903)	1	----	2295 736	----	2295 736	
	(code 904)	1	----	2295 737	----	2295 737	
	(code 908)	1	----	2295 741	----	2295 741	
	(code 909)	1	----	2295 742	----	2295 742	
	Y1-M						
	(code 921)	1	----	2295 735	----	2295 735	
	(code 923)	1	----	2295 736	----	2295 736	
	(code 924)	1	----	2295 737	----	2295 737	
	(code 925)	1	----	2295 738	----	2295 738	
	(code 928)	1	----	2295 741	----	2295 741	
	(codes 929, 939)	1	----	2295 742	----	2295 742	
	(code 951)	1	----	2295 735	----	2295 735	2430 166
	(code 955)	1	----	2295 738	----	2295 738	2430 167
	(code 956)	1	----	2295 739	----	2295 739	2430 168
	(code 957)	1	----	2295 740	----	2295 740	2430 169
	Y1-H						
	(code 941)	1	----	2295 735	----	2295 735	
	(code 943)	1	----	2295 736	----	2295 736	
	(code 944)	1	----	2295 737	----	2295 737	
	(code 949)	1	----	2295 742	----	2295 742	
	(code 975)	1	----	2295 738	----	2295 738	
	(code 976)	1	----	2295 739	----	2295 739	
	(code 977)	1	----	2295 740	----	2295 740	
23-76-57	FRAME, Rear Seat Back Center Arm Rest C3-H, Y1	1	2160 640	2160 640	----	2160 640	2410 041
23-76-59	ARM REST, Rear Door C1, C2, C3						
	(codes 101, 111, 201)						
	(blue)	1	2428 970-1	2428 970-1	2428 970-1		
	(codes 121, 221) (blue)	1	----	2180 856-7			
	(codes 102, 112) (green)	1	2428 972-3	2428 972-3			
	(codes 113, 123, 203, 223) (tan)	1	----	2428 974-5	2428 974-5		
	(codes 104, 204, 206) (black)	1	*2428 982-3	*2428 982-3	*2428 982-3		
	(codes 105, 115, 125, 205, 225, 245) (red)	1	2428 984-5	2428 984-5	2428 984-5		
	(codes 106, 208, 228) (turquoise)	1	2428 986-7	2428 986-7	2428 986-7		
	(codes 126, 227) (alabaster)	1	----	2428 978-9			
	(codes 204, 206) (black)	1	----	*2428 982-3	*2428 982-3		
	(codes 151, 251) (blue)	1	----	2182 154-5			
	C3-H						
	(codes 141, 231) (blue)	1	E2182 298-9	E2182 298-9	E2182 298-9		
	(code 142) (green)	1	E2182 300-1	E2182 300-1			
	(codes 143, 233) (tan)	1	E2182 302-3	E2182 302-3	E2182 302-3		
	(code 144) (gray)	1	E2182 304-5	E2182 304-5			
	(code 148) (turquoise)	1	E2182 306-7	E2182 306-7			
	(code 235) (red)	1	----	E2182 308-9	E2182 308-9		
	(code 236) (black)	1	----	E2182 310-1	E2182 310-1		
23-76-64	SUPPORT & BRACKET, Rear Door Arm Rest Y1	1	----	2241 234-5			

★ Indicates use as required.

E Indicates parts not listed in any previous parts book.
Jan. 3, 1964 Supersedes Jan. 25, 1963.

Printed in U.S.A.

Prices and specifications subject to change without notice.
Right and left part numbers are on same line,
first number is right, second number is left.

* Indicates change or addition.

CODE	REMARKS	PER CAR	SED.	SP. 4 D.	SUB.	SP. CL. CP.	CV. CP.
23-76-66	ARM REST, Rear Quarter C1-L						
	(code 111) (blue)	2	----	----	----	2413 934	
	(code 112) (green)	2	----	----	----	2413 935	
	(code 113) (tan)	2	----	----	----	2413 936	
	(code 115) (red)	2	----	----	----	2413 942	
	(code 201)	1	----	----	----	2413 934	2136 900-1
	(code 203)	1	----	----	----	2413 936	2136 902-3
	(code 205)	1	----	----	----	2413 942	2136 904-5
	(code 206)	1	----	----	----	2413 941	2136 906-7
	(code 208)	1	----	----	----	2413 943	2136 908-9
	C2-M						
	(code 221)	1	----	----	----	2180 858	2136 910-1
	(code 223)	1	----	----	----	2413 936	2136 902-3
	(code 225)	1	----	----	----	2413 942	2136 904-5
	(code 227)	1	----	----	----	2413 940	2136 906-7
	(code 228)	1	----	----	----	2413 943	2136 912-3
	(code 245)	1	----	----	----	2413 942	2136 904-5
	(fastener)	★	----	----	----	975 633	975 633
	Y1-L						
	(code 901)	1	----	----	----	2295 386-7	
	(code 903)	1	----	----	----	2295 388-9	
	(code 904)	1	----	----	----	2295 390-1	
	(code 908)	1	----	----	----	2295 392-3	
	(code 909)	1	----	----	----	2295 394-5	
	Y1-M						
	(code 921)	1	----	----	----	2295 412-3	
	(code 923)	1	----	----	----	2295 414-5	
	(code 924)	1	----	----	----	2295 416-7	
	(code 925)	1	----	----	----	2295 418-9	
	(code 928)	1	----	----	----	2295 424-5	
	(codes 929, 939)	1	----	----	----	2295 426-7	
	(code 951)	1	----	----	----	2295 412-3	2295 436-7
	(code 955)	1	----	----	----	2295 418-9	2295 438-9
	(code 956)	1	----	----	----	2295 420-1	2295 440-1
	(code 957)	1	----	----	----	2295 422-3	2295 442-3
23-76-79	SUPPORT, Quarter Arm Rest and Weathercord Y1	1	----	----	----	1751 534-5	1751 534-5
23-76-81	NUT, Quarter Arm Rest to Quarter Panel C1, C2	4	----	----	----	1280 134	
23-76-86	COVER, Rear Quarter Arm Rest C1-L						
	(code 201)	1	----	----	----	----	2136 914-5
	(code 203)	1	----	----	----	----	2136 916-7
	(code 205)	1	----	----	----	----	2136 918-9
	(code 206)	1	----	----	----	----	2136 920-1
	(code 208)	1	----	----	----	----	2136 922-3
	C2-M						
	(code 221)	1	----	----	----	----	2136 924-5
	(code 223)	1	----	----	----	----	2136 916-7
	(code 225)	1	----	----	----	----	2136 918-9
	(code 227)	1	----	----	----	----	2136 920-1
	(code 228)	1	----	----	----	----	2136 926-7
	(code 245)	1	----	----	----	----	2136 918-9

★ Indicates use as required.
 B Indicates parts not listed in any previous parts book.
 Right and left part numbers are on same line,
 first number is right, second number is left.
 * Indicates change or addition.

Printed in U.S.A.
 Prices and specifications subject to change without notice.
 Jan. 3, 1964 Supersedes Jan. 25, 1963.

1963 PASSENGER CAR PARTS CATALOG

INTERIOR TRIM

CODE	REMARKS	PER CAR	SED.	SP. 4 D.	SUB.	SP. CL. CP.	CV. CP.
23-76-86	COVER, Rear Quarter Arm Rest - Cont'd Y1-L (code 901) (code 903) (code 904) (code 908) (code 909)	1 1 1 1 1	---- ---- ---- ---- ----	---- ---- ---- ---- ----	---- ---- ---- ---- ----	2295 376-7 2295 378-9 2295 380-1 2295 382-3 2295 384-5	
	Y1-M (code 921) (code 923) (code 924) (code 925) (code 928) (code 929) (code 951) (code 955) (code 956) (code 957)	1 1 1 1 1 1 1 1 1 1	---- ---- ---- ---- ---- ---- ---- ---- ---- ----	---- ---- ---- ---- ---- ---- ---- ---- ---- ----	---- ---- ---- ---- ---- ---- ---- ---- ---- ----	2295 396-7 2295 398-9 2295 400-1 2295 402-3 2295 408-9 2295 410-1 2295 396-7 2295 402-3 2295 404-5 2295 406-7	2295 428-9 2295 430-1 2295 432-3 2295 434-5
23-78-2	BUTTON or MEDALLION, Tufting C1-L (chrome) (seat back) Y1-M (luggage compt. side) (gray)	1 2	---- ----	2410 817 ----	2410 817 ----	2410 817 ----	2410 817 2178 999
23-79-3	CARPET, Front Floor C1, C2, C3 (codes 101, 111, 121, 141, 201, 221, 231) (blue) (codes 102, 112, 142) (green) (codes 103, 113, 123, 143, 203, 223, 233) (tan) (codes 105, 115, 125, 205, 225, 235) (red) (codes 108, 148, 208, 228) (turquoise) (codes 126, 144, 206, 226, 227, 236) (black) (code 245) (red) (codes 151, 251) (blue) (codes 153, 253) (beige)	1 1 1 1 1 1 1 1 1 1	2299 491 2299 492 2299 493 2299 494 *2299 495 2299 496 ---- 2182 143 2182 144	2299 491 2299 492 2299 493 2299 494 *2299 495 2299 496 *2299 499 2182 143 2182 144	*2299 491 ---- *2299 493 *2299 494 ---- *2299 496 ---- ---- ----	2299 491 2299 492 2299 493 2299 494 *2299 495 2299 496 2299 499	2299 493 2299 494 *2299 495 2299 496 *2299 499
	C1, C2, C3 (std. transmission) (codes 101, 111, 121, 201, 221, 231) (blue) (codes 102, 112) (green) (codes 103, 113, 123, 203, 223) (tan) (codes 105, 115, 125, 205, 225, 245) (red) (codes 108, 208, 228) (turquoise) (codes 126, 206, 227) (black)	1 1 1 1 1 1	⊘2179 433 ⊘2179 434 ⊘2179 435 ⊘2179 436 ⊘2179 437 ----	⊘2179 433 ⊘2179 434 ⊘2179 435 ⊘2179 436 ⊘2179 437 ⊘2179 438	⊘2179 433 ---- ⊘2179 435 ⊘2179 436 ---- ⊘2179 438	⊘2179 433 ⊘2179 434 ⊘2179 435 ⊘2179 436 ⊘2179 437 ⊘2179 438	⊘2179 433 ⊘2179 435 ⊘2179 436 ⊘2179 437 ⊘2179 438
	Y1-L (code 901) (blue) (code 903) (tan) (code 904) (gray) (code 908) (turquoise) (code 909) (gold)	1 1 1 1 1	---- ---- ---- ---- ----	2421 501 2421 502 2421 503 2421 504 2421 505	---- ---- ---- ---- ----	2421 501 2421 502 2421 503 2421 504 2421 505	

★ Indicates use as required.

⊘ Indicates parts not listed in any previous parts book.

Right and left part numbers are on same line,
first number is right, second number is left.

* Indicates change or addition.

Printed in U.S.A.

Prices and specifications subject to change without notice.

Jan. 3, 1964 Supersedes Jan. 25, 1963.

CODE	REMARKS	PER CAR	SED.	SP. 4 D.	SUB.	SP. CL. CP.	CV. CP.
23-79-3	Carpet, Front Floor - Cont'd Y1-M, Y1-H (codes 921, 941, 951) (blue)	1	----	B2178 185	----	B2178 185	B2178 185
	(codes 923, 943) (tan)	1	----	2179 647	----	2179 647	
	(codes 924, 944) (gray)	1	----	2179 648	----	2179 648	
	(codes 925, 955, 975) (red)	1	----	2179 649	----	2179 649	2179 649
	(code 928) (turquoise)	1	----	2179 650	----	2179 650	
	(codes 929, 939, 949) (gold)	1	----	2179 651	----	2179 651	
	(codes 956, 957, 976, 977) (charcoal)	1	----	2179 652	----	2179 652	2179 652
23-79-33	CARPET, Rear Floor C1, C2, C3 (codes 101, 111, 121, 141, 201, 221, 231) (blue)	1	2421 522	2421 522	----	2421 522	
	(codes 102, 112, 142) (green)	1	2421 523	2421 523	----	2421 523	
	(codes 103, 113, 123, 143, 223, 233) (tan)	1	2421 524	2421 524	----	2421 524	2421 524
	(codes 105, 115, 125, 205, 225, 235, 245) (red)	1	2421 525	2421 525	----	2421 525	2421 525
	(codes 108, 148, 208, 228, 238) (turquoise)	1	2421 526	2421 526	----	2421 526	2421 526
	(codes 126, 144, 206, 226, 227, 236) (black)	1	2421 527	2421 527	----	2421 527	2421 527
	(codes 151, 251) (blue)	1	----	2182 145			
	(codes 153, 253) (beige)	1	----	2182 146			
	(codes 201, 231) (blue)	1	----	----	2421 617		
	(codes 203, 233) (tan)	1	----	----	2421 518		
	(codes 205, 235) (red)	1	----	----	2421 519		
	(codes 206, 236) (black)	1	----	----	2421 520		
	C1, C3 (carpet) (axle kick-up rear panel) (codes 201, 203, 205, 236) (black)	1	----	----	*2179 533		
	(code 231) (blue)	1	----	----	2180 879		
	(code 233) (tan)	1	----	----	2180 095		
	(code 235) (red)	1	----	----	2180 096		
	(vinoleum) (rear floor pan cover insert)						
	(code 201) (blue)	1	----	----	*2180 836		
	(codes 203, 206) (black)	1	----	----	2179 521		
	(code 205) (red)	1	----	----	2179 522		
	C1, C3 (vinoleum) (back of 2nd seat floor pan cover)						
	(code 201)	1	----	----	*2134 795		
	(code 203)	1	----	----	2134 796		
	(code 205)	1	----	----	2134 797		
	(code 206)	1	----	----	2134 798		
	(code 231)	1	----	----	2134 856		
	(code 233)	1	----	----	2134 796		
	(code 235)	1	----	----	2134 797		
	(code 236)	1	----	----	2134 798		
	(carpet) (rear floor pan insert)						
	(code 231) (blue)	1	----	----	*2180 875		
	(code 233) (tan)	1	----	----	2179 505		
	(code 235) (red)	1	----	----	2179 506		
	(code 236) (black)	1	----	----	2179 507		

★ Indicates use as required.

⊠ Indicates parts not listed in any previous parts book.

Right and left part numbers are on same line,
first number is right, second number is left.

* Indicates change or addition.

Printed in U.S.A.
Prices and specifications subject to change without notice.

1963 PASSENGER CAR PARTS CATALOG

CODE	REMARKS	PER CAR	SED.	SP. 4 D.	SUB.	SP. CL. CP.	CV. CP.
23-79-33	CARPET, Rear Floor - Cont'd C1, C3 (vinoleum) (2nd. seat to rear floor pan insert) (vinoleum)						
	(code 201) (blue)	1	----	----	*2180 835		
	(codes 203, 206) (black)	1	----	----	*1818 TX8		
	(code 205) (red)	1	----	----	*2179 520		
	(2nd. seat back to rear floor pan insert)						
	(code 231) (blue)	1	----	----	2180 874		
	(code 233) (tan)	1	----	----	2179 502		
	(code 235) (red)	1	----	----	2179 503		
	(code 236) (black)	1	----	----	2179 504		
	(3rd. seat or spare tire well riser) (carpet)						
	(code 231) (blue)	1	----	----	2180 884-5		
	(code 233) (tan)	1	----	----	2180 104-5		
	(code 235) (red)	1	----	----	2180 106-7		
	(code 236) (black)	1	----	----	2180 108-9		
	(3rd. seat or spare tire compartment floor carpet)						
	(code 231) (blue)	1	----	----	2180 877		
	(code 233) (tan)	1	----	----	2180 092		
	(code 235) (red)	1	----	----	2180 093		
	(code 236) (black)	1	----	----	2180 094		
Y1-L	(code 901) (blue)	1	----	2421 507	----	2421 512	
	(code 903) (tan)	1	----	2421 508	----	2421 513	
	(code 904) (gray)	1	----	2421 509	----	2421 514	
	(code 908) (turquoise)	1	----	2421 510	----	2421 515	
	(code 909) (gold)	1	----	2421 511	----	2421 516	
Y1-M, Y1-H	(codes 921, 941, 951)(blue)	1	----	2179 653	----	2179 660	2179 667
	(codes 923, 943) (tan)	1	----	2179 654	----	2179 661	
	(codes 924, 944) (gray)	1	----	2179 655	----	2179 662	
	(codes 925, 955, 975)(red)	1	----	2179 656	----	2179 663	2179 668
	(code 928) (turquoise)	1	----	2179 657	----	2179 664	
	(codes 929, 939, 949)(gold)	1	----	2179 658	----	2179 665	
	(codes 956, 957, 976, 977) (charcoal)	1	----	2179 659	----	2179 666	2179 669
23-79-62	INSERT, Second Seat Cushion Panel C1-L (vinoleum)						
	(code 201) (blue)	1	----	----	2180 831		
	(codes 203, 206) (black)	1	----	----	1814 TX8		
	(code 205) (red)	1	----	----	2179 512		
	C3-H						
	(code 231) (blue)	1	----	----	2180 870		
	(code 233) (tan)	1	----	----	2179 490		
	(code 235) (red)	1	----	----	2179 491		
	(code 236) (black)	1	----	----	2179 492		
23-79-64	CARPET, Luggage Compartment Floor C3-H						
	(codes 141, 142, 143, 144, 148) (w/o spare tire bracket holes)	1	2134 853	2134 853	----	2134 853	
	(codes 151, 251, 153, 253) (spare tire cover)	1	----	2295 583			
	(w/dual air cond.)	1	----	*2434 213			
	(w/o dual air cond.)	1	----	2434 247			
Y1	Rt.	1	----	2430 321	----	2430 321	
	Lt.	1	----	2295 581	----	2295 581	

★ Indicates use as required.

⊠ Indicates parts not listed in any previous parts book.
Jan. 3, 1964 Supersedes Jan. 25, 1963.

Printed in U.S.A.
Prices and specifications subject to change without notice.
Right and left part numbers are on same line,
first number is right, second number is left.
* Indicates change or addition.

CODE	REMARKS	PER CAR	SED.	SP. 4 D.	SUB.	SP. CL. CP.	CV. CP.
23-79-79	INSERT, Tailgate Inside Panel C1-L (vinoleum)						
	(code 201) (blue)	1	----	----	2180 837		
	(codes 203, 206) (black)	1	----	----	*1820 TX8		
	(code 205) (red)	1	----	----	2179 524		
	C3-H (carpet)						
	(code 231) (blue)	1	----	----	2180 876		
	(code 233) (tan)	1	----	----	2179 508		
	(code 235) (red)	1	----	----	2179 509		
	(code 236) (black)	1	----	----	2179 510		
23-82-14	HANDLE, Front Seat Back Grab C3-H, Y1 Screw (attaching)	2 4	1575 953 B9419 613	1575 953 B9419 613	----	1575 953 B9419 613	1575 953 B9419 613
23-82-20	ESCUTCHEON, Front Seat Back Grab Handle Mounting Y1 (lower) (upper)	2 2	----	2292 798 2292 800	----	2292 798 2292 800	2292 798 2292 800
23-82-30	HOOK, Coat Hanger C1, C2, C3 Y1	2 2	2165 837 ----	2165 837 1520 791	2165 837 ----	2165 837 1520 791	
23-84-3	PAD, Instrument Panel Trim C1, C2, C3 (codes 101, 111, 121, 141, 151, 201, 221, 231, 251)(blue)						
	(w/air conditioning)(upper)	1	2178 434	2178 434	*2178 434	2178 434	
	(w/o air conditioning)(upper)	1	2178 428	2178 428	*2178 428	2178 428	
	(lower)	1	2178 440	2178 440	*2178 440	2178 440	
	(codes 102, 112, 142) (green)						
	(w/air conditioning) (upper)	1	2178 435	2178 435	----	2178 435	
	(w/o air conditioning) (upper)	1	2178 429	2178 429	----	2178 429	
	(lower)	1	2178 441	2178 441	----	2178 441	
	(codes 103, 113, 123, 143, 203, 223, 233) (tan)						
	(w/air conditioning) (upper)	1	2178 436	2178 436	2178 436	2178 436	2178 436
	(w/o air conditioning)(upper)	1	2178 430	2178 430	2178 430	2178 430	2178 430
	(lower)	1	2178 442	2178 442	2178 442	2178 442	2178 442
	(codes 105, 115, 125, 205, 225, 235, 245) (red)						
	(w/air conditioning) (upper)	1	2178 437	2178 437	2178 437	2178 437	2178 437
	(w/o air conditioning)(upper)	1	2178 431	2178 431	2178 431	2178 431	2178 431
	(lower)	1	2178 443	2178 443	2178 443	2178 443	2178 443
	(codes 108, 148, 208, 228) (turquoise)						
	(w/air conditioning) (upper)	1	2178 438	2178 438	----	2178 438	2178 438
	(w/o air conditioning)(upper)	1	2178 432	2178 432	----	2178 432	2178 432
	(lower)	1	2178 444	2178 444	----	2178 444	2178 444
	(codes 104, 126, 144, 204, 206, 227, 236) (black)						
	(w/air conditioning) (upper)	1	2178 439	2178 439	2178 439	2178 439	2178 439
	(w/o air conditioning)(upper)	1	2178 433	2178 433	2178 433	2178 433	2178 433
	(lower)	1	2178 445	2178 445	2178 445	2178 445	2178 445
	(codes 153, 253) (gold)						
	(upper)	1	----	2182 096			
	(lower)	1	----	2182 097			
	(lower pad attaching clip)	7	6008 193	6008 193	6008 193	6008 193	6008 193
	(fastener) (upper panel)	7	6008 222	6008 222	6008 222	6008 222	6008 222
	Y1 (codes 901, 921, 941, 951) (blue)						
	(upper)	1	----	2178 877	----	2178 877	2178 877

★ Indicates use as required.

⊕ Indicates parts not listed in any previous parts book.
Right and left part numbers are on same line,
first number is right, second number is left.

* Indicates change or addition.

Printed in U.S.A.
Prices and specifications subject to change without notice.
Jan. 3, 1964 Supersedes Jan. 25, 1963.

1963 PASSENGER CAR PARTS CATALOG

INTERIOR TRIM

CODE	REMARKS	PER CAR	SED.	SP. 4 D.	SUB.	SP. CL. CP.	CV. CP.
23-84-3	PAD, Instrument Panel Trim - Cont'd Y1 (codes 901, 921, 941, 951) (blue)						
	(lower center)	1	----	2179 712	----	2179 712	2179 712
	(lower right)	1	----	2179 726	----	2179 726	2179 726
	(glove box door)	1	----	2179 747	----	2179 747	2179 747
	(instruments housing)	1	----	2179 761	----	2179 761	2179 761
	(ash receiver door)	1	----	2179 775	----	2179 775	2179 775
	(heater control housing)	1	----	2179 789	----	2179 789	2179 789
	(gear selector housing)	1	----	2179 803	----	2179 803	2179 803
	(codes 903, 923, 943)(tan) (upper)	1	----	2178 878	----	2178 878	
	(lower center)	1	----	2179 713	----	2179 713	
	(lower right)	1	----	2179 727	----	2179 727	
	(glove box door)	1	----	2179 748	----	2179 748	
	(instruments housing)	1	----	2179 762	----	2179 762	
	(ash receiver door)	1	----	2179 776	----	2179 776	
	(heater control housing)	1	----	2179 790	----	2179 790	
	(gear selector housing)	1	----	2179 804	----	2179 804	
	(codes 904, 924, 944)(gray) (upper)	1	----	2178 879	----	2178 879	
	(lower center)	1	----	2179 714	----	2179 714	
	(lower right)	1	----	2179 728	----	2179 728	
	(glove box door)	1	----	2179 749	----	2179 749	
	(instruments housing)	1	----	2179 763	----	2179 763	
	(ash receiver door)	1	----	2179 777	----	2179 777	
	(heater control housing)	1	----	2179 791	----	2179 791	
	(gear selector housing)	1	----	2179 805	----	2179 805	
	(codes 908, 928) (turquoise) (upper)	1	----	2178 880	----	2178 880	
	(lower center)	1	----	2179 715	----	2179 715	
	(lower right)	1	----	2179 729	----	2179 729	
	(glove box door)	1	----	2179 750	----	2179 750	
	(instruments housing)	1	----	2179 764	----	2179 764	
	(ash receiver door)	1	----	2179 778	----	2179 778	
	(heater control housing)	1	----	2179 792	----	2179 792	
	(gear selector housing)	1	----	2179 806	----	2179 806	
	(codes 909, 929, 939, 949) (upper)	1	----	2178 881	----	2178 881	
	(lower center)	1	----	2179 718	----	2179 716	
	(lower right)	1	----	2179 730	----	2179 730	
	(glove box door)	1	----	2179 751	----	2179 751	
	(instruments housing)	1	----	2179 765	----	2179 765	
	(ash receiver door)	1	----	2179 779	----	2179 779	
	(heater control housing)	1	----	2179 793	----	2179 793	
	(gear selector housing)	1	----	2179 807	----	2179 807	
	(codes 925, 955, 975)(red) (upper)	1	----	2178 882	----	2178 882	2178 882
	(lower center)	1	----	2179 717	----	2179 717	2179 717
	(lower right)	1	----	2179 731	----	2179 731	2179 731
	(glove box door)	1	----	2179 752	----	2179 752	2179 752
	(instruments housing)	1	----	2179 766	----	2179 766	2179 766
	(ash receiver door)	1	----	2179 780	----	2179 780	2179 780
	(heater control housing)	1	----	2179 794	----	2179 794	2179 794
	(gear selector housing)	1	----	2179 808	----	2179 808	2179 808
	(codes 956, 957, 976, 977) (upper) (charcoal)	1	----	2178 883	----	2178 883	2178 883
	(lower center)	1	----	2179 718	----	2179 718	2179 718
	(lower right)	1	----	2179 732	----	2179 732	2179 732
	(glove box door)	1	----	2179 753	----	2179 753	2179 753

★ Indicates use as required.

☐ Indicates parts not listed in any previous parts book.
Jan. 3, 1964 Supersedes Jan. 25, 1963.

Prices and specifications subject to change without notice.
Right and left part numbers are on same line,
first number is right, second number is left.

* Indicates change or addition.

Printed in U.S.A.

CODE	REMARKS	PER CAR	SED.	SP. 4 D.	SUB.	SP. CL. CP.	CV. CP.
23-84-3	PAD, Instrument Panel Trim - Cont'd Y1 (codes 956, 957, 976, 977)						
	(instruments housing)	1	----	2179 767	----	2179 767	2179 767
	(ash receiver door)	1	----	2179 781	----	2179 781	2179 781
	(heater control housing)	1	----	2179 795	----	2179 795	2179 795
	(gear selector housing)	1	----	2179 809	----	2179 809	2179 809
23-84-5	SPACER, Instrument Panel Trim Pad Y1 (base)	3 1	----	2491 097 B2401 230	----	2491 097 B2401 230	2491 097 B2401 230
23-84-30	CUSHION, Steering Wheel Y1						
	(blue)	1	----	2401 682	----	2401 682	2401 682
	(tan)	1	----	2401 683	----	2401 683	2401 683
	(gray)	1	----	2401 684	----	2401 684	2401 684
	(red)	1	----	2401 685	----	2401 685	2401 685
	(charcoal)	1	----	2401 686	----	2401 686	2401 686
	(turquoise)	1	----	2401 687	----	2401 687	2401 687
	(gold)	1	----	2401 688	----	2401 688	2401 688
23-84-31	ORNAMENT, Steering Wheel Cushion Y1	1	----	2401 231	----	2401 231	2401 231
23-86-2	COVER, Top of Roof Outside C3-H (black)	1	----	2182 098			
23-86-3	HEADLINING and LISTING C1-L						
	(code 101)	1		2133 005			
	(code 102)	1		2133 006			
	(codes 103, 105) (alabaster)	1		*2133 007			
	(beige)	1		2134 147			
	(code 108)	1		2133 008			
	(codes 104, 204) (police)	1		2133 009			
	(code 111)	1	----	2133 158	----	2133 158	
	(code 112)	1	----	2133 159	----	2133 159	
	(codes 113, 115) (alabaster)	1	----	*2133 160	----	*2133 160	
	(beige)	1	----	2134 213	----	2134 213	
	(code 201)	1	----	2133 158	----	2133 158	
	(codes 205, 206) (alabaster)	1	----	*2133 160	----	*2133 160	
	(beige)	1	----	2134 213	----	2134 213	
	(code 208) (turquoise)	1	----	2133 162	----	2133 162	
	C2-M						
	(codes 121, 221)	1	----	2133 158	----	2133 158	
	(codes 123, 125, 126, 223, 225, 227, 245) (alabaster)	1	----	*2133 160	----	*2133 160	
	(codes 125, 225, 245) (beige)	1	----	*2134 213	----	*2134 213	
	(code 228)	1	----	2133 162	----	2133 162	
	C3-H						
	(code 141)	1		2133 005		2133 158	
	(code 142)	1		2133 006		2133 159	
	(code 143)	1		2133 007		2133 160	
	(code 144)	1		2133 009		2133 161	
	(code 148)	1		2133 008		2133 162	
	(codes 151, 251)	1	-----	2434 086			
	(codes 153, 253)	1	----	2434 087			
	(code 231)	1	----	2133 158			
	(code 235) (alabaster)	1	----	2133 160			
	(beige)	1	----	2134 213			
	(code 236)	1	----	2133 161			

* Indicates use as required.

B Indicates parts not listed in any previous parts book.

Right and left part numbers are on same line, first number is right, second number is left.

* Indicates change or addition.

Printed in U.S.A.
Prices and specifications subject to change without notice.

Jan. 3, 1964 Supersedes Jan. 25, 1963.

CODE	REMARKS	PER CAR	SED.	SP. 4 D.	SUB.	SP. CL. CP.	CV. CP.
23-86-3	HEADLINING and LISTING - Cont'd C1, C3 (codes 201, 203, 205, 206, 231, 233, 235, 236)(white)						
	(No. 1)	1	----	----	2180 950		
	(No. 2)	1	----	----	2176 826		
	(No. 3)	1	----	----	2180 840		
	(No. 4)	1	----	----	2176 828		
	(No. 5)	1	----	----	2176 829		
	(No. 6)	1	----	----	2176 830		
	(No. 7)	1	----	----	2176 831		
	(attaching clip)	★	----	----	6000 373		
	Y1-L, Y1-M (codes 901, 921, 951)	1	----	2430 246	----	2430 246	
	(codes 903, 923)	1	----	2430 247	----	2430 247	
	(codes 904, 924)	1	----	2430 248	----	2430 248	
	(codes 908, 928)	1	----	2430 250	----	2430 250	
	(codes 956, 957)	1	----	2430 249	----	2430 249	
	(codes 925, 955) (up to serial No. 9233-100154) (alabaster)	1	----	2430 249	----	2430 249	
	(after) (beige)	1	----	2430 393	----	2430 393	
	(codes 909, 929, 939)	1	----	2430 251	----	2430 251	
	Y1-H (code 941)	1	----	2430 306			
	(code 943)	1	----	2430 307			
	(code 944)	1	----	2430 308			
	(code 949)	1	----	2430 309			
	(codes 976, 977)	1	----	2430 310			
	(code 975) (up to serial No. 9233-100154) (alabaster)	1	----	2430 310	----	2430 310	
	(after) (beige)	1	----	2430 395	----	2430 395	
23-86-8	RETAINER, Roof Panel Cover C3-H (side)	1	----	*2480 204-5			
	(rear)	1	----	*2480 002			
	Y1 (side front)	1	----	*2483 788-9	----	*2483 788-9	
	(side rear)	1	----	*2483 790-1	----	*2483 790-1	
23-86-10	SUPPORT, Roof Bow C1, C2, C3 (steel)						
	(No. 1)	1	----	----	1954 682		
	(No. 2)	1	----	----	1961 243		
	(No. 3 & 4)	1	----	----	1961 244		
	Y1 (front & rear panel)	2	----	2422 238	----	2422 238	
23-86-13	FILLER, Air Conditioning Roof Evaporating Unit Trim C1, C3	1	----	----	1914 582		
23-86-14	PAD, Air Conditioning Evaporating Unit Trim C1, C3 (paint as required)	1	----	----	2171 580		
23-86-15	PANEL, Under Rear Window Y1-H (code 941)	1	----	2430 316			
	(code 943)	1	----	2430 317			
	(code 944)	1	----	2430 318			
	(code 949)	1	----	2430 319			
	(codes 975, 976, 977)						
	(alabaster)	1	----	2430 320			
	(code 975) (beige)	1	----	2430 397			

★ Indicates use as required.

⊔ Indicates parts not listed in any previous parts book.

Jan. 3, 1964 Supersedes Jan. 25, 1963.

Page IT-206

Printed in U.S.A.

Prices and specifications subject to change without notice.

Right and left part numbers are on same line,
first number is right, second number is left.

* Indicates change or addition.

CODE	REMARKS	PER CAR	SED.	SP. 4 D.	SUB.	SP. CL. CP.	CV. CP.
23-86-19	STRIP, Roof Headlining Retaining						
	C1, C2, C3 Front	1	2244 428-9				
	Rear	1	2244 430-1				
	(fastener)	18	6000 922				
Y1	(shelf panel)	2	----	2217 910	----	2217 910	
	(screw)(to rear window side frame and roof side rail)	1	----	2080 958-9	----	2080 958-9	
	(fastener)	★	----	6023 497	----	6023 497	
		★	6000 922	6000 922	----	6000 922	
23-86-24	RETAINER, Roof Inside Finish Panel						
	C1, C2, C3 (roof headlining to roof moulding)	1	----	2419 619	----	2419 619	
	(No. 1)	1	----	----	2086 143		
	(No. 2)	1	----	----	2086 142		
	(No. 3)	1	----	----	2086 145		
	(Nos. 4 & 5)	1	----	----	2086 146		
	(No. 6)	1	----	----	2086 148		
Y1 (header trim)	1	----	*2188 680-1	----	*2188 680-1		
23-86-35	MOULDING, Roof Inside Finish Panel						
	C1, C3 (finish panel) (plastic) (chrome) (Nos. 1, 2, 3, 4, 6)	1	----	----	1905 449		
	(No. 5)	1	----	----	1759 686		
	(No. 1)	1	----	2419 531	----	2419 531	
	(No. 2)	1	----	2419 532	----	2419 532	
	(No. 3)	1	----	2419 533	----	2419 533	
23-86-36	CAP, Roof Inside Finish Moulding						
	C1, C3 (chrome)	12	----	----	1759 636		
23-91-6	PANEL, Cowl Trim						
	C1, C2, C3 (paint as required)	1	2086 612-3	2086 612-3	2086 612-3	2086 612-3	2086 612-3
Y1	C3-H (codes 151, 251) (blue)	1	----	⊖2182 364-5	----		
	(codes 153, 253) (beige)	1	----	⊖2182 366-7	----		
		1	----	2241 520-1	----	2241 520-1	2241 520-1
23-92-5	PANEL, Door Trim						
	C1-L (code 101) Front	1	2178 452-3				
	Rear	1	2178 454-5				
	(code 102) Front	1	2178 456-7				
	Rear	1	2178 458-9				
	(code 103) Front	1	2178 462-3				
	Rear	1	2178 464-5				
	(code 105) Front	1	2178 466-7				
	Rear	1	2178 468-9				
	(code 108) Front	1	2178 472-3				
	Rear	1	2178 474-5				
	(codes 104, 204) (police) Front	1	2179 546-7				
	Rear	1	⊖2179 548-9				
	(codes 111, 201) Front	1	----	2178 476-7	2178 476-7	2178 518-9	2178 518-9
	Rear	1	----	2178 478-9	2180 226-7		
	(code 112) Front	1	----	2178 482-3	----	2178 522-3	2178 522-3
	Rear	1	----	2178 484-5	----	----	----
	(codes 113, 203) Front	1	----	2178 486-7	2178 486-7	2178 526-7	2178 526-7
Rear	1	----	2178 488-9	2178 506-7			

★ Indicates use as required.

⊖ Indicates parts not listed in any previous parts book.

Right and left part numbers are on same line, first number is right, second number is left.

* Indicates change or addition.

Printed in U.S.A.

Prices and specifications subject to change without notice.

Jan. 3, 1964 Supersedes Jan. 25, 1963.

1963 PASSENGER CAR PARTS CATALOG

INTERIOR TRIM

CODE	REMARKS	PER CAR	SED.	SP. 4 D.	SUB.	SP. CL. CP.	CV. CP.
23-92-5	PANEL, Door Trim - Cont'd						
	C1-L						
	(codes 115,205) Front	1	----	2178 492-3	2178 492-3	2178 530-1	2178 530-1
	Rear	1	----	2178 494-5	2178 508-9		
	(code 206) Front	1	----	2178 496-7	2178 496-7	2178 536-7	2178 536-7
	Rear	1	----	2178 498-9	2178 510-1		
	(code 208) Front	1	----	2178 502-3	----	2178 540-1	2178 540-1
	Rear	1	----	2178 504-5			
	C2-M						
	(codes 121,221) Front	1	----	2180 214-5	----	2180 818-9	2180 818-9
	Rear	1	----	2180 216-7			
	(codes 123,223) Front	1	----	2179 006-7	----	2179 032-3	2179 032-3
	Rear	1	----	2179 008-9			
	(codes 125,225) Front	1	----	2179 012-3	----	2179 036-7	2179 036-7
	Rear	1	----	2179 014-5			
	(code 126) Front	1	----	2179 016-7			
	Rear	1	----	2179 018-9			
	(code 227) Front	1	----	2179 016-7	----	2179 046-7	2179 046-7
	Rear	1	----	2179 018-9			
	(code 228) Front	1	----	2179 026-7	----	2179 052-3	2179 052-3
	Rear	1	----	2179 028-9			
	(code 245) Front	1	----	2179 012-3	----		2179 036-7
	Rear	1	----	2179 014-5			
	C3-H						
	(codes 141,231) Front	1	2179 282-3	2179 308-9			
	Rear	1	2179 284-5	2179 310-1			
	(code 142) Front	1	2179 286-7	2179 312-3			
	Rear	1	2179 288-9	2179 314-5			
	(codes 143,233) Front	1	2179 290-1	2179 316-7			
	Rear	1	2179 292-3	2179 318-9			
	(code 144) Front	1	2179 294-5	2179 320-1			
	Rear	1	2179 296-7	2179 322-3			
	(code 148) Front	1	2179 298-9	2179 324-5			
	Rear	1	2179 300-1	2179 326-7			
	(codes 151,251) Front	1	----	2182 100-1			
	Rear	1	----	2182 102-3			
	(codes 153,253) Front	1	----	2182 106-7			
	Rear	1	----	2182 108-9			
	(code 231) Front	1	----	----	2179 308-9		
	Rear	1	----	----	2180 854-5		
	(code 233) Front	1	----	----	2179 316-7		
	Rear	1	----	----	2179 340-1		
	(code 235) Front	1	----	2179 328-9	2179 328-9		
	Rear	1	----	2179 330-1	2179 342-3		
	(code 236) Front	1	----	2179 332-3	2179 332-3		
	Rear	1	----	2179 334-5	2179 344-5		
	(code 238) Front	1	----	2179 324-5			
	Rear	1	----	2179 326-7			
	(screw w/washer)	4	6023 476	6023 476	6023 476	6023 476	6023 476
	Y1-L						
	(code 901) Front	1	----	2179 076-7	----	2179 194-5	
	Rear	1	----	2179 078-9			
	(code 903) Front	1	----	2179 080-1	----	2179 198-9	
	Rear	1	----	2179 082-3			
	(code 904) Front	1	----	2179 084-5	----	2179 202-3	
	Rear	1	----	2179 086-7			
	(code 908) Front	1	----	2179 088-9	----	2179 206-7	
	Rear	1	----	2179 090-1			
	(code 909) Front	1	----	2179 092-3	----	2179 210-1	
	Rear	1	----	2179 094-5			
	(fastener)	★	975 633	975 633	----	975 633	975 633
	(screw w/washer)	★	6023 476				

★ Indicates use as required.

□ Indicates parts not listed in any previous parts book.
Jan. 3, 1964 Supersedes Jan. 25, 1963.

Printed in U.S.A.
Prices and specifications subject to change without notice.
Right and left part numbers are on same line,
first number is right, second number is left.
* Indicates change or addition.

CODE	REMARKS	PER CAR	SED.	SP. 4 D.	SUB.	SP. CL. CP.	CV. CP.
23-92-5	PANEL, Door Trim - Cont'd Y1-M						
	(code 921) Front	1	----	2179 112-3	----	2179 222-3	
	Rear	1	----	2179 114-5			
	(code 923) Front	1	----	2179 116-7	----	2179 226-7	
	Rear	1	----	2179 118-9			
	(code 924) Front	1	----	2179 120-1	----	2179 230-1	
	Rear	1	----	2179 122-3			
	(code 925) Front	1	----	2179 124-5	----	2179 234-5	
	Rear	1	----	2179 126-7			
	(code 928) Front	1	----	2179 128-9	----	2179 238-9	
	Rear	1	----	2179 130-1			
	(codes 929, 939) Front	1	----	2179 132-3	----	2179 242-3	
	Rear	1	----	2179 134-5			
	(code 951) Front	1	----	2179 112-3	----	2179 222-3	2179 222-3
	Rear	1	----	2179 114-5			
	(code 955) Front	1	----	2179 124-5	----	2179 234-5	2179 234-5
	Rear	1	----	2179 126-7			
	(code 956) Front	1	----	2179 150-1	----	2179 246-7	2179 246-7
	Rear	1	----	2179 152-3			
	(code 957) Front	1	----	2179 154-5	----	2179 250-1	2179 250-1
	Rear	1	----	2179 156-7			
	Y1-H						
	(code 941) Front	1	----	2179 162-3			
	Rear	1	----	2179 164-5			
	(code 943) Front	1	----	2179 166-7			
	Rear	1	----	2179 168-9			
	(code 944) Front	1	----	2179 170-1			
	Rear	1	----	2179 172-3			
	(code 949) Front	1	----	2179 174-5			
	Rear	1	----	2179 176-7			
	(code 975) Front	1	----	2179 180-1			
	Rear	1	----	2179 182-3			
	(code 977) Front	1	----	2179 184-5			
	Rear	1	----	2179 186-7			
	(code 976) Front	1	----	2180 792-3			
	Rear	1	----	2180 794-5			
	Fastener	★	6000 365	6000 365	6000 365	6000 365	6000 365
	Screw & Washer	★	6023 476	6023 476	6023 476	6023 476	6000 106
	Screw (door trim panel at belt retainer)	★	----	9413 197	----	9413 197	
23-92-8	FASTENER, Quarter Trim Panel C1, C2, Y1	★	975 633	975 633	----	975 633	975 633
23-92-25	RETAINER, Door Trim Panel at Belt Y1	4	----	2161 879	----	2161 879	2161 879
23-96-3	PANEL, Luggage Compartment Front Lining C1, C2, C3 Y1	1 1	2180 880 ----	2180 880 2178 193	----	2180 880 2178 193	E2180 973 2175 373
23-96-8	PANEL or COVER, Luggage Compartment Side C1, C2, C3 (paint as required) (codes 151, 251, 153, 253) (code 201) (code 203) (code 205) (code 206)	1 1 1 1 1	2180 882-3 ----	2180 882-3 2434 214-5 ----	----	2180 882-3	2180 976-7
					2180 200-1		
					2180 110-1		
					2180 112-3		
					2180 114-5		

★ Indicates use as required.

⊠ Indicates parts not listed in any previous parts book.
Right and left part numbers are on same line,
first number is right, second number is left.

* Indicates change or addition.

Printed in U.S.A.
Prices and specifications subject to change without notice.
Jan. 3, 1964 Supersedes Jan. 25, 1963.

1963 PASSENGER CAR PARTS CATALOG

CODE	REMARKS	PER CAR	SED.	SP. 4 D.	SUB.	SP. CL. CP.	CV. CP.
23-96-8	PANEL or COVER, Luggage Compartment Side - Cont'd C1, C2, C3 (rear sill cover)(vinyl)						
	(codes 201, 231)	1	----	----	*2434 206		
	(codes 203, 233)	1	----	----	2434 207		
	(codes 205, 235)	1	----	----	2434 208		
	(codes 206, 236)	1	----	----	2434 209		
	C3-H (w/ledge cover)						
	(code 231)	1	----	----	2134 900-1		
	(code 233)	1	----	----	2134 902-3		
	(code 235)	1	----	----	2134 904-5		
	(code 236)	1	----	----	2134 906-7		
	(panel)						
	(code 231)	1	----	----	*2180 212-3		
	(code 233)	1	----	----	2180 128-9		
	(code 235)	1	----	----	2180 130-1		
	(code 236)	1	----	----	2180 132-3		
	Y1 (paint as required)(gray)	1	----	2180 700-1	----	2180 700-1	2180 702-3
23-96-10	COVER, Luggage Compartment Deck Opening Lower Y1	1	----	B2295 582	----	B2295 582	B2295 582
23-99-4	COVER, Center Pillar Trim C1, C2, C3 (paint as required) Y1 (paint as required)	1 1	----	*2802-3 VT8 2179 910-1	*2802-3 VT8 ----	*2802-3 VT8 2179 910-1	*2802-3 VT8 2179 910-1
23-99-41	COVER, Center Pillar Trim Retainer Y1 (sold by the inch)						
	(codes 901, 921, 941, 951) (blue)	★	----	2181 796			
	(codes 903, 923, 943) (tan)	★	----	2181 797			
	(codes 904, 924, 944) (gray)	★	----	2181 798			
	(codes 908, 928) (turquoise)	★	----	2181 799			
	(codes 909, 929, 939, 949) (gold)	★	----	2181 800			
	(codes 925, 955, 975) (red)	★	----	2181 801			
	(codes 956, 976) (black)	★	----	2181 802			
	(codes 957, 977) (alabaster)	★	----	2181 803			
23-101-3	PANEL, Rear Quarter Trim C1-L						
	(code 101)	1	2134 530-1				
	(code 102)	1	2134 532-3				
	(code 103)	1	2134 534-5				
	(code 105)	1	2134 536-7				
	(code 108)	1	2134 538-9				
	(code 104) (police)	1	2134 506-7				
	(code 204) (police)	1	2133 716-7				
	(code 111)	1	----	2134 992-3	----	2178 520-1	
	(code 112)	1	----	2134 994-5	----	2178 524-5	
	(code 113)	1	----	2134 996-7	----	2178 528-9	
	(code 115)	1	----	2134 988-9	----	2178 532-3	
	(code 201)	1	----	2134 942-3	----	2178 520-1	2180 196-7
	(code 203)	1	----	----	----	----	2180 198-9
	(code 205)	1	----	2134 988-9	----	2178 532-3	2178 548-9
	(code 206)	1	----	2134 618-9	----	2178 538-9	2178 550-1
	(code 208)	1	----	2134 990-1	----	2178 542-3	2178 552-3
	C2-M						
	(code 121)	1	----	2134 620-1	----	----	----
	(code 123)	1	----	2134 622-3	----	----	----

★ Indicates use as required.
 B Indicates parts not listed in any previous parts book.
 Jan. 3, 1964 Supersedes Jan. 25, 1963.

Printed in U.S.A.
 Prices and specifications subject to change without notice.
 Right and left part numbers are on same line,
 first number is right, second number is left.
 * Indicates change or addition.

CODE	REMARKS	PER CAR	SED.	SP. 4 D.	SUB.	SP. CL. CP.	CV. CP.
23-101-3	PANEL, Rear Quarter Trim - Cont'd C2-M						
	(code 125)	1	----	2134 988-9	----	----	----
	(code 126)	1	----	2134 618-9	----	----	----
	(code 221)	1	----	2134 620-1	----	*2180 820-1	2180 822-3
	(code 223)	1	----	2134 622-3	----	2179 034-5	2179 060-1
	(codes 225, 245)	1	----	2134 988-9	----	2179 038-9	2179 062-3
	(code 227)	1	----	2134 618-9	----	2179 048-9	2179 066-7
	(code 228)	1	----	2134 990-1	----	2179 054-5	2179 068-9
	C3-H						
	(code 141)	1	2134 500-1	2134 992-3			
	(code 142)	1	2134 502-3	2134 994-5			
	(code 143)	1	2134 504-5	2134 996-7			
	(code 144)	1	2134 506-7	2134 998-9			
	(code 148)	1	2134 508-9	2134 990-1			
	(codes 151, 251) (upper)	1	----	2434 152-3			
	(lower)	1	----	2434 136-7			
	(codes 153, 253) (upper)	1	----	2434 154-5			
	(code 231)	1	----	2134 992-3			
	(lower)	1	----	2434 138-9			
	(code 233)	1	----	2134 996-7			
	(code 235)	1	----	2134 988-9			
	(code 236)	1	----	2134 624-5			
	(screw w/washer)	★	6023 476	6023 476	----	6023 476	6023 476
	Y1-L						
	(code 901)	1	----	2295 360-1	----	2179 196-7	
	(code 903)	1	----	2295 362-3	----	2179 200-1	
	(code 904)	1	----	2295 364-5	----	2179 204-5	
	(code 908)	1	----	2295 372-3	----	2179 208-9	
	(code 909)	1	----	2295 374-5	----	2179 212-3	
	Y1-M						
	(code 921)	1	----	2295 360-1	----	2179 224-5	
	(code 923)	1	----	2295 362-3	----	2179 228-9	
	(code 924)	1	----	2295 364-5	----	2179 232-3	
	(code 925)	1	----	2295 366-7	----	2179 236-7	
	(code 928)	1	----	2295 372-3	----	2179 240-1	
	(codes 929, 939)	1	----	2295 374-5	----	2179 244-5	
	(code 951)	1	----	2295 360-1	----	2179 224-5	2179 258-9
	(code 955)	1	----	2295 366-7	----	2179 236-7	2179 260-1
	(code 956)	1	----	2295 368-9	----	2179 248-9	2179 262-3
	(code 957)	1	----	2295 370-1	----	2179 252-3	2179 264-5
	(fastener)	★	----	975 633	----	975 633	975 633
	Y1-H						
	(code 941)	1	----	2295 360-1			
	(code 943)	1	----	2295 362-3			
	(code 944)	1	----	2295 364-5			
	(code 949)	1	----	2295 374-5			
	(code 975)	1	----	2295 366-7			
	(code 976)	1	----	2295 368-9			
	(code 977)	1	----	2295 370-1			
	(fastener)	★	6000 365	----	----	6000 365	6000 365
23-102-3	PANEL, Shelf Trim C1, C2, C3						
	(paint as required)						
	(black)	1	2179 274	2179 274	----	2179 274	
	Y1 (paint as required)						
	(charcoal)	1	----	2180 689	----	2180 689	
	(fastener)	★	6000 903	6000 903	----	6000 903	

★ Indicates use as required.

⊠ Indicates parts not listed in any previous parts book.
Right and left part numbers are on same line,
first number is right, second number is left.

* Indicates change or addition.

Printed in U.S.A.

Prices and specifications subject to change without notice.

1963 PASSENGER CAR PARTS CATALOG

INTERIOR TRIM

CODE	REMARKS	PER CAR	SED.	SP. 4 D.	SUB.	SP. CL. CP.	CV. CP.
23-103-3	PANEL, Visor Trim C1, C2, C3 (codes 101, 111, 121, 141, 201, 221, 231) (blue)	2	⊕2182 213	⊕2182 213	----	⊕2182 213	
	(codes 102, 112, 142)(green)	2	⊕2182 214	⊕2182 214	----	⊕2182 214	
	(codes 104, 144, 204, 206, 236)(gray)	2	2178 586	2178 586			
	(codes 103, 105, 113, 115, 123, 125, 126, 143, 205, 206, 223, 225, 227, 235, 245) (alabaster)	2	⊕2182 215	⊕2182 215	----	⊕2182 215	
	(codes 105, 115, 125, 205, 225, 235, 245) (beige)	2	⊕2182 218	⊕2182 218	----	⊕2182 218	
	(codes 108, 148, 208, 228) (turquoise)	2	⊕2182 216	⊕2182 216	----	⊕2182 216	
	(codes 151, 251) (blue)	2	----	2182 140			
	(codes 153, 253) (beige)	2	----	2182 141			
	(codes 201, 203, 205, 206, 231, 233, 235, 236, 245)(white) (w/inst. panel mounted mirror) (white)	2	----	----	2180 075		
	(code 201) (blue)	2	----	----	2179 401		
	(code 203) (tan)	2	----	----	----	----	2180 863
	(code 221) (blue)	2	----	----	----	----	2180 862
							2180 860
	(code 223)(up to serial No. 218920) (tan)	2	----	----	----	----	*2178 564
	(after) (tan)	2	----	----	----	----	*2180 862
	(codes 205, 225, 245) (red)	2	----	----	----	----	2178 566
	(code 206) (black)	2	----	----	----	----	2178 568
	(code 227) (alabaster)	2	----	----	----	----	2178 572
	(codes 208, 228) (turquoise)	2	----	----	----	----	2178 570
	(padded) (white)	2	2178 557	2178 557	2212 272	2178 557	
	Y1-L, Y1-M (codes 901, 921, 951)(blue)	2	----	2179 834	----	2179 834	
	(codes 903, 923) (tan)	2	----	2179 835	----	2179 835	
	(codes 904, 924) (gray)	2	----	2179 836	----	2179 836	
	(codes 956, 957) (alabaster)	2	----	2179 839	----	2179 839	
	(codes 908, 928) (turquoise)	2	----	2179 837	----	2179 837	
	(codes 909, 929) (gold)	2	----	2179 838	----	2179 838	
	Y1-M (code 951) (blue)	2	----	----	----	----	2179 855
	(code 955) (red)	2	----	----	----	----	2179 856
	(codes 956, 957) (charcoal)	2	----	----	----	----	2179 857
	Y1-H (code 941) (blue)	2	----	2179 834	----		
	(code 943) (tan)	2	----	2179 835	----		
	(code 944) (gray)	2	----	2179 836	----		
	(codes 939, 949) (gold)	2	----	2179 838	----		
	(codes 977) (alabaster)	2	----	2179 839	----		
	Y1-L, Y1-M, Y1-H (codes 925, 955, 975) (up to serial No. 9233-100154) (alabaster)	2	----	2179 839	----	2179 839	
	(after) (beige)	2	----	2178 175	----	2178 175	

★ Indicates use as required.

⊕ Indicates parts not listed in any previous parts book.
Jan. 3, 1964 Supersedes Jan. 25, 1963.Printed in U.S.A.
Prices and specifications subject to change without notice.Right and left part numbers are on same line,
first number is right, second number is left.

* Indicates change or addition.

CODE	REMARKS	PER CAR	SED.	SP. 4 D.	SUB.	SP. CL. CP.	CV. CP.
23-103-10	ARM and BRACKET, Visor C1, C2, C3						
	(chrome)	1	2292 946-7	2292 946-7	2292 946-7	2292 946-7	1954 926-7
	(tension spring washer)	2	6000 106	6000 106	6000 106	6000 106	6000 106
	(w/dual air cond.)	2	----	----	*2292 108-9	----	----
Y1		1	----	2085 242-3	----	2085 242-3	2161 588-9
23-103-34	SPRING, w/HOOK, Windshield Upper Garnish Moulding Visor Y1	2	----	1900 776	----	1900 776	2161 810
23-103-37	SPACER, Visor Support Hook C1, C3	1	----	----	2165 039		
	Screw (attaching)	1	----	----	* 274 109		
23-103-48	SUPPORT, Visor Inner C1, C2, C3	2	2162 628	2162 628	2162 628	2162 628	2162 628
	(for padded visor) (long)	2	----	----	2193 096		
	Y1-M	2	----	2161 687	----	2161 687	2241 382
23-108-4	CUSHION, Front Seat C1-L						
	(code 101)	1	2133 052				
	(w/airfoam pad)	1	2133 137				
	(6 way elec.)	1	2133 122				
	(6 way elec. w/airfoam pad)	1	2133 147				
	(code 102)	1	2133 053				
	(w/airfoam pad)	1	2133 138				
	(6 way elec.)	1	2133 123				
	(6 way elec. w/airfoam pad)	1	2133 148				
	(code 103)	1	2133 054				
	(w/airfoam pad)	1	2133 139				
	(6 way elec.)	1	2133 124				
	(6 way elec. w/airfoam pad)	1	2133 149				
	(code 105)	1	2133 055				
(w/airfoam pad)	1	2133 140					
(6 way elec.)	1	2133 125					
(6 way elec. w/airfoam pad)	1	2133 150					
(code 108)	1	2133 056					
(w/airfoam pad)	1	2133 141					
(6 way elec.)	1	2133 126					
(6 way elec. w/airfoam pad)	1	2133 151					
(code 104)	1	2133 065					
(code 204)	1	2133 549					
(police)							
(code 101)	1	2134 373					
(code 102)	1	2134 374					
(code 103)	1	2134 375					
(code 105)	1	2134 376					
(code 108)	1	2134 377					
(code 111)	1	----	2133 206	----	2133 334		
(w/airfoam pad)	1	----	2133 286	----	2133 390		
(6 way elec.)	1	----	2133 274	----	2133 378		
(6 way elec. w/airfoam pad)	1	----	2133 294	----	2133 398		
(code 112)	1	----	2133 207	----	2133 335		
(w/airfoam pad)	1	----	2133 287	----	2133 391		
(6 way elec.)	1	----	2133 275	----	2133 379		
(6 way elec. w/airfoam pad)	1	----	2133 295	----	2133 399		
(code 113)	1	----	2133 208	----	2133 336		
(w/airfoam pad)	1	----	2133 288	----	2133 392		
(6 way elec.)	1	----	2133 276	----	2133 380		
(6 way elec. w/airfoam pad)	1	----	2133 296	----	2133 400		

★ Indicates use as required.

☐ Indicates parts not listed in any previous parts book.

Right and left part numbers are on same line,
first number is right, second number is left.

* Indicates change or addition.

Printed in U.S.A.
Prices and specifications subject to change without notice.

Jan. 3, 1964 Supersedes Jan. 25, 1963.

1963 PASSENGER CAR PARTS CATALOG

INTERIOR TRIM

CODE	REMARKS	PER CAR	SED.	SP. 4 D.	SUB.	SP. CL. CP.	CV. CP.
23-108-4	CUSHION, Front Seat - Cont'd C1-L						
	(code 115)	1	----	2133 209	----	2133 337	
	(w/airfoam pad)	1	----	2133 289	----	2133 393	
	(6 way elec.)	1	----	2133 277	----	2133 381	
	(6 way elec. w/airfoam pad)	1	----	2133 297	----	2133 401	
	(code 201)	1	----	2134 689	2134 689	2134 677	2134 677
	(6 way elec.)	1	----	----	2134 706		
	(police and ambulance)	1	----	----	2134 762		
	(code 203)	1	----	2133 422	----	----	2134 678
	(police and ambulance)	1	----	----	2134 228		
	(6 way electric)	1	----	2133 466			
	(code 205)	1	----	2133 423	----	2133 540	2133 540
	(police and ambulance)	1	----	----	2134 229		
	(6 way elec.)	1	----	2133 467	----	2133 575	2133 575
	(code 206)	1	----	2133 424	----	2133 541	2133 541
	(police and ambulance)	1	----	----	2134 230		
	(6 way elec.)	1	----	2133 468	----	2133 712	2133 712
	(code 208)	1	----	2133 425	----	2133 542	2133 542
	(6 way elec.)	1	----	2133 469	----	2133 713	2133 713
	C2-M						
	(code 121)	1	----	2134 654			
	(6 way elec.)	1	----	2134 670			
	(code 123)	1	----	2133 847			
	(6 way elec.)	1	----	2133 868			
	(code 125)	1	----	2133 848			
	(6 way elec.)	1	----	2133 869			
	(code 126)	1	----	2133 849			
	(6 way elec.)	1	----	2133 870			
	(code 221)	2	----	2134 814	----	2134 814	2134 814
	Center	1	----	2134 816	----	2134 816	2134 816
	(code 223)	2	----	2133 642	----	2133 642	2133 642
	Center	1	----	2134 293	----	2134 293	2134 293
	(code 225)	2	----	2133 643	----	2133 643	2133 643
	Center	1	----	2133 663	----	2133 663	2133 663
	(code 227)	2	----	2133 645	----	2133 645	2133 645
	Center	1	----	2133 665	----	2133 665	2133 665
	(code 228)	2	----	2133 646	----	2133 646	2133 646
	Center	1	----	2133 666	----	2133 666	2133 666
	(code 245)	2	----	2134 927	----	2134 927	2134 927
	Center	1	----	2134 647	----	2134 647	2134 647
	SCREW & WASHER (center cushion to mounting bracket)	★	----	* 180 077	----	* 180 077	* 180 077
	C3-H						
	(code 141)	1	2133 955	2133 955			
	(6 way elec.)	1	2134 035	2134 035			
	(code 142)	1	2133 956	2133 956			
	(6 way elec.)	1	2134 036	2134 036			
	(code 143)	1	2133 957	2133 957			
	(6 way elec.)	1	2134 037	2134 037			
	(code 144)	1	2133 958	2133 958			
	(6 way elec.)	1	2134 038	2134 038			
	(code 148)	1	2133 959	2133 959			
	(6 way elec.)	1	2134 039	2134 039			
	(code 151)	1	----	2434 020			
	(code 251)	1	----	2434 021			
	(code 153)	1	----	2434 062			
	(code 253)	1	----	2434 063			
	(code 231)	2	----	2134 873	2134 873		
	(code 233)	1	----	2134 875	2134 875		
	Center	2	----	----	2133 888		
	Center	1	----	----	2133 662		

★ Indicates use as required.

ⓑ Indicates parts not listed in any previous parts book.

Jan. 3, 1964 Supersedes Jan. 25, 1963.

* Indicates change or addition.

Printed in U.S.A.

Prices and specifications subject to change without notice.

Right and left part numbers are on same line,
first number is right, second number is left.

CODE	REMARKS	PER CAR	SED.	SP. 4 D.	SUB.	SP. CL. CP.	CV. CP.
23-108-4	CUSHION, Front Seat - Cont'd						
	C3-H						
	(code 235)	2	----	2133 889	2133 889		
	Center	1	----	2133 663	2133 663		
	(code 236)	2	----	2133 890	2133 890		
	Center	1	----	2133 664	2133 664		
	Y1-L						
	(code 901)	1	----	2295 821	----	2295 836	
	(6 way elec.)	1	----	2295 826	----	2295 841	
	(code 903)	1	----	2295 822	----	2295 837	
	(6 way elec.)	1	----	2295 827	----	2295 842	
	(code 904)	1	----	2295 823	----	2295 838	
	(6 way elec.)	1	----	2295 828	----	2295 843	
	(code 908)	1	----	2295 824	----	2295 839	
	(6 way elec.)	1	----	2295 829	----	2295 844	
	(code 909)	1	----	2295 825	----	2295 840	
	(6 way elec.)	1	----	2295 830	----	2295 845	
	Y1-M						
	(code 921)	1	----	2430 140	----	2430 140	
	(code 923)	1	----	2430 141	----	2430 141	
	(code 924)	1	----	2430 142	----	2430 142	
	(code 925)	1	----	2430 143	----	2430 143	
	(code 928)	1	----	2430 144	----	2430 144	
	(code 929)	1	----	2430 145	----	2430 145	
	(code 939)	1	----	2430 358	----	2430 358	
	(code 951)	1	----	2430 150	----	2430 150	2430 150
	(code 955)	1	----	2430 151	----	2430 151	2430 151
	(code 956)	1	----	2430 152	----	2430 152	2430 152
	(code 957)	1	----	2430 153	----	2430 153	2430 153
	Y1-H						
	(code 941)	1	----	2430 060			
	(code 943)	1	----	2430 061			
	(code 944)	1	----	2430 062			
	(code 949)	1	----	2430 063			
	(code 975)	1	----	2430 151			
	(code 976)	1	----	2430 152			
	(code 977)	1	----	2430 153			
23-108-5	COVER, Front Seat Cushion						
	C1-L						
	(code 101)	1	2133 057				
	(code 102)	1	2133 058				
	(code 103)	1	2133 059				
	(code 105)	1	2133 060				
	(code 108)	1	2133 061				
	(code 104) (police)	1	2133 066				
	(code 204) (police)	1	2133 550				
	(code 111)	1	----	2133 210	----	2133 338	
	(code 112)	1	----	2133 211	----	2133 339	
	(code 113)	1	----	2133 212	----	2133 340	
	(code 115)	1	----	2133 213	----	2133 341	
	C1-L, C2-M						
	(code 201)	1	----	*2134 690	*2134 690	*2134 746	*2134 746
	(code 203)	1	----	----	2133 426	----	2134 747
	(code 205)	1	----	2133 427	2133 427	2133 543	2133 543
	(code 206)	1	----	2133 428	2133 428	2133 544	2133 544
	(code 208)	1	----	2133 429	----	2133 545	2133 545
	(code 121)	1	----	2134 655			
	(code 123)	1	----	2133 850			
	(code 125)	1	----	2133 851			
	(code 126)	1	----	2133 852			

★ Indicates use as required.
 B Indicates parts not listed in any previous parts book.
 Right and left part numbers are on same line,
 first number is right, second number is left.
 * Indicates change or addition.

1963 PASSENGER CAR PARTS CATALOG

INTERIOR TRIM

CODE	REMARKS	PER CAR	SED.	SP. 4 D.	SUB.	SP. CL. CP.	CV. CP.
23-108-5	COVER, Front Seat Cushion - Cont'd						
	C1-L, C2M						
	(code 221)	2	----	2134 815	----	2134 815	2134 815
	Center	1	----	2134 817	----	2134 817	2134 817
	(code 223)	2	----	2133 647	----	2133 647	2133 647
	Center	1	----	2134 294	----	2134 294	2134 294
	(code 225)	2	----	2133 648	----	2133 648	2133 648
	Center	1	----	2133 668	----	2133 668	2133 668
	(code 227)	2	----	2133 650	----	2133 650	2133 650
	Center	1	----	2133 670	----	2133 670	2133 670
	(code 228)	2	----	2133 651	----	2133 651	2133 651
	Center	1	----	2133 671	----	2133 671	2133 671
	(code 245)	2	----	2134 928	----	2134 928	2134 928
	Center	1	----	2134 648	----	2134 648	2134 648
	C3-H						
	(code 141)	1	2133 960	2133 960			
	(code 142)	1	2133 961	2133 961			
	(code 143)	1	2133 962	2133 962			
	(code 144)	1	2133 963	2133 963			
	(code 148)	1	2133 964	2133 964			
	(code 151)	1	----	2434 022			
	(code 153)	1	----	2434 023			
	(code 251)	1	----	2434 064			
	(code 253)	1	----	2434 065			
	(code 231)	2	----	2134 874	2134 874		
	Center	1	----	2134 876	2134 876		
	(code 233)	2	----	----	2133 892		
	Center	1	----	----	2133 667		
	(code 235)	2	----	2133 893	2133 893		
	Center	1	----	2133 668	2133 668		
	(code 236)	2	----	2133 894	2133 894		
	Center	1	----	2133 669	2133 669		
	C3-H (body cloth)						
	(code 141)	1	B2434 305	B2434 305			
	(code 143)	1	B2434 306	B2434 306			
	(code 148)	1	B2434 307	B2434 307			
	Y1-L						
	(code 901)	1	----	2295 816	----	2295 831	
	(code 903)	1	----	2295 817	----	2295 832	
	(code 904)	1	----	2295 818	----	2295 833	
	(code 908)	1	----	2295 819	----	2295 834	
	(code 909)	1	----	2295 820	----	2295 835	
	Y1-M						
	(code 921)	1	----	2430 134	----	2430 134	
	(code 923)	1	----	2430 135	----	2430 135	
	(code 924)	1	----	2430 136	----	2430 136	
	(code 925)	1	----	2430 137	----	2430 137	
	(code 928)	1	----	2430 138	----	2430 138	
	(code 929)	1	----	2430 139	----	2430 139	
	(code 939)	1	----	2430 359	----	2430 359	
	(code 951)	1	----	2430 146	----	2430 146	2430 146
	(code 955)	1	----	2430 147	----	2430 147	2430 147
	(code 956)	1	----	2430 148	----	2430 148	2430 148
	(code 957)	1	----	2430 149	----	2430 149	2430 149
	Y1-H						
	(code 941)	1	----	2430 056			
	(code 943)	1	----	2430 057			
	(code 944)	1	----	2430 058			
	(code 949)	1	----	2430 059			

★ Indicates use as required.

⊠ Indicates parts not listed in any previous parts book.

Jan. 3, 1964 Supersedes Jan. 25, 1963.

Printed in U.S.A.

Prices and specifications subject to change without notice.

Right and left part numbers are on same line,
first number is right, second number is left.

* Indicates change or addition.

CODE	REMARKS	PER CAR	SED.	SP. 4 D.	SUB.	SP. CL. CP.	CV. CP.
23-108-5	COVER, Front Seat Cushion - Cont'd Y1-H						
	(code 975)	1	----	2430 147			
	(code 976)	1	----	2430 148			
	(code 977)	1	----	2430 149			
23-108-6	FLAP, Back of Front Seat Cushion C2, C3						
	(codes 221, 231)	2	----	2434 250	2434 250	2434 250	2434 250
	(codes 223, 233)	2	----	2434 251	2434 251	2434 251	2434 251
	(codes 225, 235, 245)	2	----	2434 252	2434 252	2434 252	2434 252
	(codes 227, 236)	2	----	2434 253	2434 253	2434 253	2434 253
	(code 228)	2	----	2434 254	2434 254	2434 254	2434 254
23-108-12	BACK, Front Seat (less cushion) C1-L						
	(police)						
	(code 103)	1	2134	370			
	(code 105)	1	2134	371			
	(code 108)	1	2134	372			
	(code 101)	1	2133	037			
	(code 102)	1	2133	038			
	(code 103)	1	2133	039			
	(code 105)	1	2133	040			
	(code 108)	1	2133	041			
	(code 104) (police)	1	2133	063			
	(code 204) (police)	1	2133	547			
	(code 111)	1	----	2133 189	----	2133 318-9	
	(code 112)	1	----	2133 190	----	2133 320-1	
	(code 113)	1	----	2133 191	----	2133 322-3	
	(code 115)	1	----	2133 192	----	2133 324-5	
	(code 201)	1	----	2134 685	2134 685	2134 730-1	2134 730-1
	(police and ambulance)	1	----	----	2134 761		
	(code 203)	1	----	----	2133 406	----	2134 732-3
	(police and ambulance)	1	----	----	2134 219		
	(code 205)	1	----	2133 407	2133 407	2133 528-9	2133 528-9
	(police and ambulance)	1	----	----	2134 220		
	(code 206)	1	----	2133 408	2133 408	2133 530-1	2133 530-1
	(police and ambulance)	1	----	----	2134 221		
	(code 208)	1	----	2133 409	----	2133 532-3	2133 532-3
	C2-M						
	(code 121)	1	----	2134 651			
	(code 123)	1	----	2133 503			
	(code 125)	1	----	2133 504			
	(code 126)	1	----	2133 505			
23-108-14	PAD, Front Seat Back Corner Stuffing C3-H	2	----	B2494 565			
23-108-15	SPRING and COVER, Front Seat Back C3-H						
	(code 141)	1	2133	940	2133 940		
	(code 142)	1	2133	941	2133 941		
	(code 143)	1	2133	942	2133 942		
	(code 144)	1	2133	943	2133 943		
	(code 148)	1	2133	944	2133 944		
	(code 151)	1	----	----	2434 006-7		
	(code 251)	1	----	----	2434 048-9		
	(code 153)	1	----	----	2434 008-9		
	(code 253)	1	----	----	2434 050-1		
	(code 233)	2	----	----	----	2134 099	
	(code 235)	2	----	----	2134 100	2134 100	
	(code 236)	2	----	----	2134 101	2134 101	

★ Indicates use as required.
 B Indicates parts not listed in any previous parts book.
 Right and left part numbers are on same line,
 first number is right, second number is left.
 * Indicates change or addition.

Printed in U.S.A.
 Prices and specifications subject to change without notice.
 Jan. 3, 1964 Supersedes Jan. 25, 1963.

1963 PASSENGER CAR PARTS CATALOG

INTERIOR TRIM

CODE	REMARKS	PER CAR	SED.	SP. 4 D.	SUB.	SP. CL. CP.	CV. CP.
23-108-15	SPRING and COVER, Front Seat Back - Cont'd						
	C2-M						
	(code 221)	2	----	2134 807	----	2134 807	2134 807
	(code 223)	2	----	2133 606	----	2133 606	2133 606
	(code 225)	2	----	2133 607	----	2133 607	2133 607
	(code 227)	2	----	2133 609	----	2133 609	2133 609
	(code 228)	2	----	2133 610	----	2133 610	2133 610
	(code 245)	2	----	2134 923	----	2134 923	2134 923
	C3-H						
	(code 231)	2	----	2134 867	2134 867		
	(code 233)	2	----	----	2134 099		
	(code 235)	2	----	2134 100	2134 100		
	(code 236)	2	----	2134 101	2134 101		
	Y1-L						
	(code 901)	Rt. 1	----	2295 907	----	2430 114	
		Lt. 1	----	----	----	2430 119	
	(code 903)	Rt. 1	----	2295 908	----	2430 115	
		Lt. 1	----	----	----	2430 120	
	(code 904)	Rt. 1	----	2295 909	----	E2430 116	
		Lt. 1	----	----	----	2430 121	
	(code 908)	Rt. 1	----	2295 910	----	2430 117	
		Lt. 1	----	----	----	2430 122	
	(code 909)	Rt. 1	----	2295 911	----	2430 118	
		Lt. 1	----	----	----	2430 123	
	Y1-M						
	(code 921)	Rt. 1	----	2295 874	----	2295 874	
		Lt. 1	----	2295 880	----	2295 880	
	(code 923)	Rt. 1	----	2295 875	----	2295 875	
		Lt. 1	----	2295 881	----	2295 881	
	(code 924)	Rt. 1	----	2295 876	----	2295 876	
		Lt. 1	----	E2295 882	----	2295 882	
	(code 925)	Rt. 1	----	2295 877	----	2295 877	
		Lt. 1	----	2295 883	----	2295 883	
	(code 928)	Rt. 1	----	2295 878	----	2295 878	
		Lt. 1	----	2295 884	----	2295 884	
	(code 929)	Rt. 1	----	2295 879	----	2295 879	
		Lt. 1	----	2295 885	----	2295 885	
	(code 939)	1	----	2430 356-7	----	2430 356-7	
	(code 951)	Rt. 1	----	2295 886	----	2295 886	2295 886
		Lt. 1	----	2295 890	----	2295 890	2295 890
	(code 955)	Rt. 1	----	2295 887	----	2295 887	2295 887
		Lt. 1	----	2295 891	----	2295 891	2295 891
	(code 956)	Rt. 1	----	2295 888	----	2295 888	E2295 888
		Lt. 1	----	2295 892	----	2295 892	2295 892
	(code 957)	Rt. 1	----	E2295 889	----	2295 889	E2295 889
		Lt. 1	----	2295 893	----	2295 893	2295 893
	Y1-H						
	(code 941)	Rt. 1	----	2295 894			
		Lt. 1	----	2295 898			
	(code 943)	Rt. 1	----	2295 895			
		Lt. 1	----	2295 899			
	(code 944)	Rt. 1	----	2295 896			
		Lt. 1	----	2295 900			
	(code 949)	Rt. 1	----	2295 897			
		Lt. 1	----	2295 901			
	(code 975)	Rt. 1	----	2295 887			
		Lt. 1	----	2295 891			
	(code 976)	Rt. 1	----	2295 888			
		Lt. 1	----	2295 892			
	(code 977)	Rt. 1	----	2295 889			
		Lt. 1	----	2295 893			

★ Indicates use as required.

⊠ Indicates parts not listed in any previous parts book.

Right and left part numbers are on same line, first number is right, second number is left.

* Indicates change or addition.

Printed in U.S.A.

Prices and specifications subject to change without notice.

Jan. 3, 1964 Supersedes Jan. 25, 1963.

CODE	REMARKS	PER CAR	SED.	SP. 4 D.	SUB.	SP. CL. CP.	CV. CP.
23-108-16	COVER, Front Seat Back						
	C1-L						
	(code 101)	1	2133 042				
	(code 102)	1	2133 043				
	(code 103)	1	2133 044				
	(code 105)	1	2133 045				
	(code 108)	1	2133 046				
	(code 104) (police)	1	2133 064				
	(code 204) (police)	1	2133 548				
	(code 111)	1	----	2133 193	----	2133 326-7	
	(code 112)	1	----	2133 194	----	2133 328-9	
	(code 113)	1	----	2133 195	----	2133 330-1	
	(code 115)	1	----	2133 196	----	2133 332-3	
	(code 201)	1	----	2134 686	2134 686	2134 734-5	2134 734-5
	(code 203)	1	----	----	2133 410	----	2134 736-7
	(code 205)	1	----	2133 411	2133 411	2133 534-5	2133 534-5
	(code 206)	1	----	2133 412	2133 412	2133 536-7	2133 536-7
	(code 208)	1	----	2133 413	----	2133 538-9	2133 538-9
	C2-M						
	(code 121)	1	----	2134 652			
	(code 123)	1	----	2133 515			
	(code 125)	1	----	2133 516			
	(code 126)	1	----	2133 517			
	(code 221)	2	----	2134 808	----	2134 808	2134 808
	(code 223)	2	----	2133 611	----	2133 611	2133 611
	(code 225)	2	----	2133 612	----	2133 612	2133 612
	(code 227)	2	----	2133 614	----	2133 614	2133 614
	(code 228)	2	----	2133 615	----	2133 615	2133 615
	(code 245)	2	----	2134 924	----	2134 924	2134 924
	C3-H						
	(code 141)	1	2134 945	2134 945			
	(code 142)	1	2134 946	2134 946			
	(code 143)	1	2134 947	2134 947			
	(code 144)	1	2134 948	2134 948			
	(code 148)	1	2134 949	2134 949			
	(code 151)	1	----	2434 010-1			
	(code 153) Rt.	1	----	2434 012			
	Lt.	1	----	2434 013			
	(code 251)	1	----	2434 052-3			
	(code 253)	1	----	2434 054-5			
	(code 231)	2	----	2134 868	2134 868		
	(code 233)	2	----	*2134 103	2134 103		
	(code 235)	2	----	*2134 104	2134 104		
	(code 236)	2	----	*2134 105	2134 105		
	C3-H (body cloth)						
	(code 141)	1	⊖2434 290	⊖2434 290			
	(code 143)	1	⊖2434 291	⊖2434 291			
	(code 148)	1	⊖2434 292	⊖2434 292			
	Y1-L						
	(code 901) Rt.	1	----	2295 902	----	2430 104	
	Lt.	1	----	----	----	2430 109	
	(code 903) Rt.	1	----	2295 903	----	2430 105	
	Lt.	1	----	----	----	2430 110	
	(code 904) Rt.	1	----	2295 904	----	2430 106	
	Lt.	1	----	----	----	2430 111	
	(code 908) Rt.	1	----	2295 905	----	2430 107	
	Lt.	1	----	----	----	2430 112	
	(code 909) Rt.	1	----	2295 906	----	2430 108	
	Lt.	1	----	----	----	2430 113	

★ Indicates use as required.

⊖ Indicates parts not listed in any previous parts book.

Right and left part numbers are on same line, first number is right, second number is left.

* Indicates change or addition.

Printed in U.S.A.

Prices and specifications subject to change without notice.

Jan. 3, 1964 Supersedes Jan. 25, 1963.

1963 PASSENGER CAR PARTS CATALOG

INTERIOR TRIM

CODE	REMARKS	PER CAR	SED.	SP. 4 D.	SUB.	SP. CL. CP.	CV. CP.
23-108-16	COVER, Front Seat Back - Cont'd Y1-M						
	(code 921) Rt.	1	----	2295 846	----	2295 846	
	Lt.	1	----	2295 852	----	2295 852	
	(code 923) Rt.	1	----	2295 847	----	2295 847	
	Lt.	1	----	2295 853	----	2295 853	
	(code 924) Rt.	1	----	2295 848	----	2295 848	
	Lt.	1	----	2295 854	----	2295 854	
	(code 925) Rt.	1	----	2295 849	----	2295 849	
	Lt.	1	----	2295 855	----	2295 855	
	(code 928) Rt.	1	----	2295 850	----	2295 850	
	Lt.	1	----	2295 856	----	2295 856	
	(code 929) Rt.	1	----	2295 851	----	2295 851	
	Lt.	1	----	2295 857	----	2295 857	
	(code 939)	1	----	2430 360-1	----	2430 360-1	
	(code 951) Rt.	1	----	2295 858	----	2295 858	2295 858
	Lt.	1	----	2295 862	----	2295 862	2295 862
	(code 955) Rt.	1	----	2295 859	----	2295 859	2295 859
	Lt.	1	----	2295 863	----	2295 863	2295 863
	(code 956) Rt.	1	----	2295 860	----	2295 860	2295 860
	Lt.	1	----	2295 864	----	2295 864	2295 864
	(code 957) Rt.	1	----	2295 861	----	2295 861	
	Lt.	1	----	2295 865	----	2295 865	
	(code 975) Rt.	1	----	2295 859			
	Lt.	1	----	2295 863			
	(code 977) Rt.	1	----	2295 861			
	Lt.	1	----	2295 865			
	Y1-H						
	(code 941) Rt.	1	----	2295 866			
	Lt.	1	----	2295 870			
	(code 943) Rt.	1	----	2295 867			
	Lt.	1	----	2295 871			
	(code 944) Rt.	1	----	2295 868			
	Lt.	1	----	2295 872			
	(code 949) Rt.	1	----	2295 869			
	Lt.	1	----	2295 873			
	(code 975) Rt.	1	----	2295 859			
	Lt.	1	----	2295 863			
	(code 976) Rt.	1	----	2295 860			
	Lt.	1	----	2295 864			
	(code 977) Rt.	1	----	2295 861			
	Lt.	1	----	2295 865			
23-108-18	CASING, Front Seat Back Headrest C3-H	2	----	*2446 657			
23-108-19	HEAD REST, Front Seat Back C3-H						
	(codes 151, 251)	2	----	2434 216			
	(codes 153, 253)	2	----	2434 217			
23-108-20	COVER, Front Seat Back Head Rest Finish C3-H						
	(codes 151, 251)	2	----	*2182 162			
	(codes 153, 253)	2	----	*4345 TL4			
23-108-21	TAPE, Head Rest Closure Hook C3-H (sold by the inch)						
	(black)	★	----	*1934 TX8			
	(loop) (black)	★	----	*1933 TX8			

★ Indicates use as required.

E Indicates parts not listed in any previous parts book.
Jan. 3, 1964 Supersedes Jan. 25, 1963.Printed in U.S.A.
Prices and specifications subject to change without notice.
Right and left part numbers are on same line,
first number is right, second number is left.
* Indicates change or addition.

CODE	REMARKS	PER CAR	SED.	SP. 4 D.	SUB.	SP. CL. CP.	CV. CP.
23-108-22	COVER, Front Seat Reclining Mechanism C3-H (codes 151, 251) (codes 153, 253)	1 1	----	*2182 260 *2703 TL4			
23-108-27	SPRING, Front Seat Cushion to Back Retarder C1, C2	2	----	----	----	*2092 242	*2092 242
23-108-32	PANEL or COVER, Back of Front Seat Back C2-M (for console jobs) (panel) (code 221) (code 223) (codes 225, 245) (code 227) (code 228) (panel) (code 231) (code 233) (code 236) (code 235) (fastener)	2 2 2 2 2 2 2 2 2 2 14	----	2434 261 2434 262 *2434 263 2434 264 2434 265 2434 244 2434 245 2434 246 *2434 263 *6000 365	----	2434 261 2434 262 *2434 263 2434 264 2434 265 2434 244 2434 245 2434 246 *2434 263 *6000 365	2434 261 2434 262 *2434 263 2434 264 2434 265
	C3-H (panel) (code 141) (code 142) (code 143) (code 144) (code 148) (panel) (upper) (codes 151, 251) (codes 153, 253)	1 1 1 1 1 2 2	2180 136 2180 137 2180 138 2180 139 2180 140 ----	2180 136 2180 137 2180 138 2180 139 2180 140 H2434 258 H2434 259			
	Y1-L (panel) (code 901) (code 903) (code 904) (code 908) (code 909)	Rt. 1 Lt. 1 Rt. 1 Lt. 1 Rt. 1 Lt. 1 Rt. 1 Lt. 1	----	2295 589 ----- 2295 590 ----- 2295 591 ----- 2295 592 ----- 2295 593 -----	----	2295 589 ----- 2295 590 ----- 2295 591 ----- 2295 592 ----- 2295 593 -----	2295 599 2295 609 2295 600 2295 610 2295 601 2295 611 2295 602 2295 612 2295 603 2295 613
	Y1-M (code 921) (code 923) (code 924) (code 925) (code 928) (code 929) (panel assy) (less fasteners)	Rt. 1 Lt. 1 Rt. 1 Lt. 1 Rt. 1 Lt. 1 Rt. 1 Lt. 1 1	----	2430 000 2430 006 2430 001 2430 007 2430 002 2430 008 2430 003 2430 009 2430 004 2430 010 2430 005 2430 011 2430 366-7	----	2430 000 2430 006 2430 001 2430 007 2430 002 2430 008 2430 003 2430 009 2430 004 2430 010 2430 005 2430 011 2430 366-7	

★ Indicates use as required.
 ☐ Indicates parts not listed in any previous parts book.
 Right and left part numbers are on same line,
 first number is right, second number is left.
 * Indicates change or addition.

Printed in U.S.A.
 Prices and specifications subject to change without notice.
 Jan. 3, 1964 Supersedes Jan. 25, 1963.

1963 PASSENGER CAR PARTS CATALOG

INTERIOR TRIM

CODE	REMARKS	PER CAR	SED.	SP. 4 D.	SUB.	SP. CL. CP.	CV. CP.
23-108-32	PANEL, or COVER, Back of Front Seat Back - Cont'd Y1-H						
	(code 941) (blue)	1	----	2180 606-7			
	(code 943) (tan)	1	----	2180 608-9			
	(code 944) (gray)	1	----	2180 610-1			
	(code 949) (gold)	1	----	2180 612-3			
	(code 975) (red)	1	----	2180 614-5			
	(code 976) (charcoal)	1	----	2180 796-7			
	(code 977) (alabaster)	1	----	2180 616-7			
	Y1-M						
	(code 951) Rt.	1	----	⊕2430 040	----	⊕2430 040	⊕2430 040
	Lt.	1	----	⊕2430 044	----	⊕2430 044	⊕2430 044
	(code 955) Rt.	1	----	⊕2430 041	----	⊕2430 041	⊕2430 041
	Lt.	1	----	⊕2430 045	----	⊕2430 045	⊕2430 045
	(code 956) Rt.	1	----	⊕2430 042	----	⊕2430 042	⊕2430 042
	Lt.	1	----	⊕2430 046	----	⊕2430 046	⊕2430 046
	(code 957) Rt.	1	----	⊕2430 043	----	⊕2430 043	⊕2430 043
	Lt.	1	----	⊕2430 047	----	⊕2430 047	⊕2430 047
23-108-33	COMPARTMENT, Back of Front Seat Back Storage C3-H						
	(code 151)	1	----	2182 264-5			
	(code 251)	1	----	2182 268-9			
	(code 153)	1	----	2182 266-7			
	(code 253)	1	----	2182 270-1			
23-108-66	COVER, Front Seat Center Arm Rest Stanchion C3-H (black)	1	----	*4388-9 TX8	*4388-9 TX8		
23-108-71	BRACKET, Front Seat Center Cushion Frame Mounting Side C2, C3	2	----	2410 066	2410 066	2410 065	2410 066
23-108-98	SHIELD, Front Seat Side C3-H, Y1-L						
	(upper) (anodized)	1	2292 820-1	2292 820-1			
	C1, C2, C3, Y1-L (cushion)(manual and power) (anodized) Rt.	1	2080 732	2080 732	2080 732	2080 732	2080 732
	(cushion)(power) (anodized) Lt.	1	2080 733	2080 733	2080 733	2080 733	2080 733
	(cushion)(manual) (anodized) Lt.	1	2080 737	2080 737	2080 737	2080 737	2080 737
	C2, C3 (bucket seats) (cushion) (anodized)	1	----	2292 492-3	2292 492-3	2292 492-3	2292 492-3
	(back) (anodized)	2	----	2161 236-7	2161 236-7	2161 236-7	2161 236-7
	C3-H (cushion shield) (codes 151,251)	1	----	2182 256-7			
	(codes 153,253) (back shield)	1	----	2182 258-9			
	(codes 151,251)	1	----	2182 272-3			
	(codes 153,253)	1	----	2182 274-5			
	Y1-M						
	(upper) (primed)	1	----	2292 862-3			
	(lower) (primed)	1	----	----	----	2292 864-5	2292 864-5
	Screw (lower shield to seat frame)	4	* 161 928	* 161 928	* 161 928	2080 516-7	2080 516-7

★ Indicates use as required.

⊕ Indicates parts not listed in any previous parts book.

Jan. 3, 1964 Supersedes Jan. 25, 1963.

Printed in U.S.A.

Prices and specifications subject to change without notice.

Right and left part numbers are on same line,

first number is right, second number is left.

* Indicates change or addition.

CODE	REMARKS	PER CAR	SED.	SP. 4 D.	SUB.	SP. CL. CP.	CV. CP.	
23-108-98	SHIELD, Front Seat Side - Cont'd Y1-H (code 941) (blue) (code 943) (tan) (code 944) (gray) (code 949) (gold) (code 975) (red) (code 976) (charcoal) (code 977) (alabaster) (screw) (to seat frame) (spacer clip) (nut & washer)	1 1 1 1 1 1 1 4 2 4	---- ---- ---- ---- ---- ---- ---- ---- 6008 217 ----	2180 504-5 2180 506-7 2180 508-9 2180 510-1 2180 512-3 2180 798-9 2180 514-5 ---- 6008 217 6023 201	---- ---- ---- ---- ---- ---- ---- ---- 6008 217 6023 201	---- ---- ---- ---- ---- ---- ---- ---- 6008 217 6023 201	6000 471 6008 217 6023 201	6000 471 6008 217 6023 201
23-108-99	COVER, Front Seat Side Shield Protector C3-H (cushion) (codes 151, 251) (codes 153, 253) (back) (codes 151, 251) (codes 153, 253)	1 1 1 1	---- ---- ---- ----	*2434 224-5 2434 226-7 2434 232-3 2434 234-5				
	Y1-M (black)	1	----	----	----	2176 472-3	2176 472-3	
	Y1-H (code 941) (code 943) (code 944) (code 949) (code 975) (code 977) (code 976)	1 1 1 1 1 1 1	---- ---- ---- ---- ---- ---- ----	2430 154-5 2430 156-7 2430 158-9 2430 164-5 2430 160-1 *2430 162-3 E2430 464-5				
23-108-142	BRACKET, Front Seat Cushion Side Shield Support C2, C3	2	----	2292 475	2292 475	2292 475	2292 475	
23-109-3	BACK, Rear Seat C1-L (police) (code 101) (code 102) (code 103) (code 105) (code 108) (code 101) (code 102) (code 103)	1 1 1 1 1 1 1 1 1	2134 378 2134 379 2134 380 2134 381 2134 382 2133 067 2133 068 2133 069					
	(code 105) (code 108) (code 104) (police) (code 204) (police) (code 111) (code 112) (code 113) (code 115)	1 1 1 1 1 1 1 1	2133 070 2133 071 2133 077 2133 596 ---- ---- ---- ----	2133 222 2133 223 2133 224 2133 225	---- ---- ---- ----	2133 222 2133 223 2133 224 2133 225		
	(code 201) (2nd seat) (code 203) (2nd seat) (code 205) (2nd seat) (code 206) (2nd seat) (code 208) (3rd seat)	1 1 1 1 1	---- ---- ---- ---- ----	2134 693 ---- 2133 438 2133 439 2133 440	2134 710 2134 718 2133 470 2133 494 2133 471 2133 495 2133 472 2133 496 ----	2134 693 ---- 2133 438 2133 439 2133 440	2137 272 2137 273 2137 274 2137 275 2137 276	

★ Indicates use as required.

E Indicates parts not listed in any previous parts book.

Right and left part numbers are on same line, first number is right, second number is left.

* Indicates change or addition.

Printed in U.S.A.

Prices and specifications subject to change without notice.

Jan. 3, 1964 Supersedes Jan. 25, 1963.

* Indicates change or addition.

1963 PASSENGER CAR PARTS CATALOG

INTERIOR TRIM

CODE	REMARKS	PER CAR	SED.	SP. 4 D.	SUB.	SP. CL. CP.	CV. CP.
23-109-3	BACK, Rear Seat - Cont'd						
	C2-M						
	(code 121)	1	----	2137 375			
	(code 123)	1	----	2137 376			
	(code 125)	1	----	2137 377			
	(code 126)	1	----	2137 378			
	(code 221)	1	----	2137 379	----	2137 379	2137 778
	(code 223)	1	----	2137 380	----	2137 380	2137 779
	(code 225)	1	----	2137 381	----	2137 381	2137 780
	(code 227)	1	----	2137 382	----	2137 382	2137 781
	(code 228)	1	----	2137 383	----	2137 383	2137 782
	(code 245)	1	----	2137 107	----	2137 107	2136 999
	C3-H (spring and cover)						
	(code 141)	1	2133 970	2133 970			
	(code 142)	1	2133 971	2133 971			
	(code 143)	1	2133 972	2133 972			
	(code 144)	1	2133 973	2133 973			
	(code 148)	1	2133 974	2133 974			
	(code 151)	1	----	2434 026			
	(code 251)	1	----	2434 068			
	(code 153)	1	----	2434 027			
	(code 253)	1	----	2434 069			
	C3-H						
	(code 231) (2nd seat)	1	----	----	2134 888		
	(code 231) (3rd seat)	1	----	----	2134 892		
	(code 233) (2nd seat)	1	----	----	2134 153		
	(code 233) (3rd seat)	1	----	----	2134 165		
	(code 235) (2nd seat)	1	----	----	2134 154		
	(code 235) (3rd seat)	1	----	----	2134 166		
	(code 236) (2nd seat)	1	----	----	2134 155		
	(code 236) (3rd seat)	1	----	----	2134 167		
	(attaching nut)	3	----	----	6000 234		
	C3-H (spring and cover)						
	(code 231)	1	----	2134 878			
	(code 235)	1	----	2134 122			
	(code 236)	1	----	2134 123			
	Y1-L (spring and cover)						
	(code 901)	1	----	2295 692	----	2295 922	
	(code 903)	1	----	2295 693	----	2295 923	
	(code 904)	1	----	2295 694	----	2295 924	
	(code 908)	1	----	2295 695	----	2295 925	
	(code 909)	1	----	2295 696	----	2295 926	
	Y1-M (spring and cover)						
	(code 921)	1	----	2295 717	----	2295 944	
	(code 923)	1	----	2295 718	----	2295 945	
	(code 924)	1	----	2295 719	----	2295 946	
	(code 925)	1	----	2295 720	----	2295 947	
	(code 928)	1	----	2295 721	----	2295 948	
	(code 929)	1	----	2295 722	----	2295 949	
	(code 951)	1	----	2295 731	----	2295 964	2430 186
	(code 955)	1	----	2295 732	----	2295 965	2430 187
	(code 956)	1	----	2295 733	----	2295 966	2430 188
	(code 957)	1	----	2295 734	----	2295 967	2430 189
	Y1-H (spring and cover)						
	(code 941)	1	----	2295 793			
	(code 943)	1	----	2295 794			
	(code 944)	1	----	2295 795			
	(code 949)	1	----	2295 796			
	(code 975)	1	----	2295 781			
	(code 976)	1	----	2430 392			
	(code 977)	1	----	2295 782			

★ Indicates use as required.

⊠ Indicates parts not listed in any previous parts book.

Jan. 3, 1964 Supersedes Jan. 25, 1963.

Printed in U.S.A.

Prices and specifications subject to change without notice.

Right and left part numbers are on same line, first number is right, second number is left.

* Indicates change or addition.

CODE	REMARKS	PER CAR	SED.	SP. 4 D.	SUB.	SP. CL. CP.	CV. CP.
23-109-4	COVER, Rear Seat Back C1-L						
	(code 101)	1	2133 072				
	(code 102)	1	2133 073				
	(code 103)	1	2133 074				
	(code 105)	1	2133 075				
	(code 108)	1	2133 076				
	(code 104) (police)	1	2133 078				
	(code 204) (police)	1	2133 597				
	(code 111)	1	----	2133 226	----	2133 226	
	(code 112)	1	----	2133 227	----	2133 227	
	(code 113)	1	----	2133 228	----	2133 228	
	(code 115)	1	----	2133 229	----	2133 229	
	(code 201) (2nd seat)	1	----	2134 694	2134 711	2134 694	2134 772
	(code 203) (3rd seat)	1	----	----	2134 719	----	
	(code 203) (2nd seat)	1	----	----	2133 473	----	2134 773
	(code 205) (3rd seat)	1	----	----	2133 497	----	
	(code 205) (2nd seat)	1	----	2133 441	2133 474	2133 441	2133 564
	(code 206) (3rd seat)	1	----	----	2133 498	----	
	(code 206) (2nd seat)	1	----	2133 442	2133 475	2133 442	2133 565
	(code 208) (3rd seat)	1	----	----	2133 499	----	
	(code 208) (2nd seat)	1	----	2133 443	----	2133 443	2133 566
	C2-M						
	(code 121)	1	----	2134 659			
	(code 123)	1	----	2133 856			
	(code 125)	1	----	2133 857			
	(code 126)	1	----	2133 858			
	(code 221)	1	----	2134 819	----	2134 819	2134 847
	(code 223)	1	----	2133 677	----	2133 677	2133 833
	(code 225)	1	----	2133 678	----	2133 678	2133 834
	(code 227)	1	----	2133 680	----	2133 680	2133 836
	(code 228)	1	----	2133 681	----	2133 681	2133 837
	(code 245)	1	----	2134 930	----	2134 930	2134 937
	C3-H						
	(code 141)	1	2133 975	2133 975			
	(code 142)	1	2133 976	2133 976			
	(code 143)	1	2133 977	2133 977			
	(code 144)	1	2133 978	2133 978			
	(code 148)	1	2133 979	2133 979			
	(code 151)	1	----	2434 028			
	(code 153)	1	----	2434 029			
	(code 251)	1	----	2434 070			
	(code 253)	1	----	2434 071			
	(code 231) (2nd seat)	1	----	2134 879	2134 889		
	(code 231) (3rd seat)	1	----	----	2134 893		
	(code 233) (2nd seat)	1	----	----	2134 156		
	(code 233) (3rd seat)	1	----	----	2134 168		
	(code 235) (2nd seat)	1	----	2134 125	2134 157		
	(code 235) (3rd seat)	1	----	----	2134 169		
	(code 236) (2nd seat)	1	----	2134 126	2134 158		
	(code 236) (3rd seat)	1	----	----	2134 170		
	C3-H (body cloth)						
	(code 141)	1	⊕2434 314	⊕2434 314			
	(code 143)	1	⊕2434 315	⊕2434 315			
	(code 148)	1	⊕2434 316	⊕2434 316			
	Y1-L						
	(code 901) Rt.	1	----	2295 682	----	2295 912	
	(code 901) Lt.	1	----	2295 687	----	2295 917	

★ Indicates use as required.

⊕ Indicates parts not listed in any previous parts book.

Right and left part numbers are on same line, first number is right, second number is left.

* Indicates change or addition.

Printed in U.S.A.

Prices and specifications subject to change without notice.

Jan. 3, 1964 Supersedes Jan. 25, 1963.

1963 PASSENGER CAR PARTS CATALOG

INTERIOR TRIM

CODE	REMARKS	PER CAR	SED.	SP. 4 D.	SUB.	SP. CL. CP.	CV. CP.
23-109-4	COVER, Rear Seat Back - Cont'd						
	Y1-L						
	(code 903) Rt.	1	----	2295 683	----	2295 913	
	Lt.	1	----	2295 688	----	2295 918	
	(code 904) Rt.	1	----	2295 684	----	2295 914	
	Lt.	1	----	2295 689	----	2295 919	
	(code 908) Rt.	1	----	2295 685	----	2295 915	
	Lt.	1	----	2295 690	----	2295 920	
	(code 909) Rt.	1	----	2295 686	----	2295 916	
	Lt.	1	----	2295 691	----	2295 921	
	Y1-M						
	(code 921) Rt.	1	----	2295 705	----	2295 932	
	Lt.	1	----	2295 711	----	2295 938	
	(code 923) Rt.	1	----	2295 706	----	2295 933	
	Lt.	1	----	2295 712	----	2295 939	
	(code 924) Rt.	1	----	2295 707	----	2295 934	
	Lt.	1	----	2295 713	----	2295 940	
	(code 925) Rt.	1	----	2295 708	----	2295 935	
	Lt.	1	----	2295 714	----	2295 941	
	(code 928) Rt.	1	----	2295 709	----	2295 936	
	Lt.	1	----	2295 715	----	2295 942	
	(code 929) Rt.	1	----	2295 710	----	2295 937	
	Lt.	1	----	2295 716	----	2295 943	
	(code 939)	1	----	2430 374-5	----	⊠2430 376-7	
	(code 951) Rt.	1	----	2295 723	----	2295 956	2430 178
	Lt.	1	----	2295 727	----	2295 960	2430 182
	(code 955) Rt.	1	----	2295 724	----	2295 957	2430 179
	Lt.	1	----	2295 728	----	2295 961	2430 183
	(code 956) Rt.	1	----	2295 725	----	2295 958	2430 180
	Lt.	1	----	2295 729	----	2295 962	2430 184
	(code 957) Rt.	1	----	2295 726	----	2295 959	2430 181
	Lt.	1	----	2295 730	----	2295 963	2430 185
	Y1-H						
	(code 941) Rt.	1	----	2295 785	----		
	Lt.	1	----	2295 789	----		
	(code 943) Rt.	1	----	2295 786	----		
	Lt.	1	----	2295 790	----		
	(code 944) Rt.	1	----	2295 787	----		
	Lt.	1	----	2295 791	----		
	(code 949) Rt.	1	----	2295 788	----		
	Lt.	1	----	2295 792	----		
	(code 975) Rt.	1	----	2295 777	----		
	Lt.	1	----	2295 779	----		
	(code 976)	1	----	2430 390-1	----		
	(code 977) Rt.	1	----	2295 778	----		
	Lt.	1	----	2295 780	----		
23-109-5	INSERT or COVER, Rear Seat Back Rear Panel						
	C1-L (insert)						
	(code 201) (2nd seat)	1	----	----	2180 832		
	(3rd seat)	1	----	----	2180 834		
	(code 203) (2nd seat)	1	----	----	*1816 TX4		
	(3rd seat)	1	----	----	*1815 TX8		
	(code 205) (2nd seat)	1	----	----	2179 514		
	(3rd seat)	1	----	----	2179 518		
	(code 206) (2nd seat)	1	----	----	*1816 TX8		
	(3rd seat)	1	----	----	*1815 TX8		

★ Indicates use as required.

⊠ Indicates parts not listed in any previous parts book.
Jan. 3, 1964 Supersedes Jan. 25, 1963.

Printed in U.S.A.

Prices and specifications subject to change without notice.

Right and left part numbers are on same line,
first number is right, second number is left.

* Indicates change or addition.

CODE	REMARKS	PER CAR	SED.	SP. 4 D.	SUB.	SP. CL. CP.	CV. CP.
23-109-5	INSERT or COVER, Rear Seat Back Rear Panel - Cont'd C3-H (insert)						
	(code 231) (2nd seat)	1	----	----	2180 871		
	(3rd seat)	1	----	----	2180 873		
	(code 233) (2nd seat)	1	----	----	2179 493		
	(3rd seat)	1	----	----	2179 499		
	(code 235) (2nd seat)	1	----	----	2179 494		
	(3rd seat)	1	----	----	2179 500		
	(code 236) (2nd seat)	1	----	----	2179 495		
	(3rd seat)	1	----	----	2179 501		
	Y1-M						
	(code 951)	1	----	----	----	----	2295 996
	(code 955)	1	----	----	----	----	2295 997
	(code 956)	1	----	----	----	----	2295 998
	(code 957)	1	----	----	----	----	2295 999
	(fastener)	★	----	6000 365	----	6000 365	6000 365
23-109-16	COVER, Rear Seat Back Radio Speaker C1, C2						
	(code 201)	1	----	----	----	----	2434 187
	(code 221)	1	----	----	----	----	2434 192
	(codes 203, 223)	1	----	----	----	----	2434 188
	(codes 205, 225, 245)	1	----	----	----	----	2434 189
	(codes 206, 227)	1	----	----	----	----	2434 190
	(code 208)	1	----	----	----	----	2434 191
	(code 228)	1	----	----	----	----	2434 193
23-109-19	PLATE and COVER, Rear Back Radio Speaker Grille C1, C2						
	(code 201)	1	----	----	----	----	2434 180
	(code 221)	1	----	----	----	----	2434 185
	(codes 203, 223)	1	----	----	----	----	2434 181
	(codes 205, 225, 245)	1	----	----	----	----	2434 182
	(codes 206, 227)	1	----	----	----	----	2434 183
	(code 208)	1	----	----	----	----	2434 184
23-109-35	CUSHION, Rear Seat C1-L						
	(police)						
	(code 101)	1	2134 383				
	(code 102)	1	2134 384				
	(code 103)	1	2134 385				
	(code 105)	1	2134 386				
	(code 108)	1	2134 387				
	(code 101)	1	2133 082				
	(w/airfoam pad)	1	2133 127				
	(code 102)	1	2133 083				
	(w/airfoam pad)	1	2133 128				
	(code 103)	1	2133 084				
	(w/airfoam pad)	1	2133 129				
	(code 105)	1	2133 085				
	(w/airfoam pad)	1	2133 130				
	(code 108)	1	2133 086				
	(w/airfoam pad)	1	2133 131				
	(code 104)	1	2133 079				
	(w/airfoam pad)	1	2133 620				
	(w/airfoam pad and heavy duty spring)	1	2133 197				
	(code 204)	1	2133 598				
	(w/airfoam pad)	1	2133 620				

★ Indicates use as required.

☐ Indicates parts not listed in any previous parts book.

Right and left part numbers are on same line,
first number is right, second number is left.

* Indicates change or addition.

Printed in U.S.A.
Prices and specifications subject to change without notice.

Jan. 3, 1964 Supersedes Jan. 25, 1963.

1963 PASSENGER CAR PARTS CATALOG

INTERIOR TRIM

CODE	REMARKS	PER CAR	SED.	SP. 4 D.	SUB.	SP. CL. CP.	CV. CP.
23-109-35	CUSHION, Rear Seat - Cont'd						
	C1-L						
	(code 111)	1	----	2133 238	----	2133 350	
	(w/airfoam pad)	1	----	2133 278	----	2133 382	
	(code 112)	1	----	2133 239	----	2133 351	
	(w/airfoam pad)	1	----	2133 279	----	2133 383	
	(code 113)	1	----	2133 240	----	2133 352	
	(w/airfoam pad)	1	----	2133 280	----	2133 384	
	(code 115)	1	----	2133 241	----	2133 353	
	(w/airfoam pad)	1	----	2133 281	----	2133 385	
	(code 201)	1	----	2134 698	2134 721	2134 752	2134 778
	(code 203)	1	----	----	2133 482	----	2134 779
	(3rd seat)	1	----	----	2133 506		
	(code 205)	1	----	2133 450	2133 483	2133 552	2133 567
	(2nd seat)	1	----	----	2133 507		
	(code 206)	1	----	2133 451	2133 484	2133 553	2133 568
	(3rd seat)	1	----	----	2133 508		
	(code 208)	1	----	2133 452	----	2133 554	2133 569
	(spring attach. nut)	3	----	----	6000 234		
	C2-M						
	(code 121)	1	----	2134 661			
	(code 123)	1	----	2133 859			
	(code 125)	1	----	2133 860			
	(code 126)	1	----	2133 861			
	(code 221)	1	----	2134 820	----	2134 836	2134 848
	(code 223)	1	----	2133 682	----	2134 580	2134 590
	(code 225)	1	----	2133 683	----	2134 581	2134 591
	(code 227)	1	----	2133 685	----	2134 583	2134 593
	(code 228)	1	----	2133 686	----	2134 584	2134 594
	(code 245)	1	----	2134 931	----	2134 940	2134 938
	C3-H						
	(code 141)	1	2134 000	2134 000			
	(code 142)	1	2134 001	2134 001			
	(code 143)	1	2134 002	2134 002			
	(code 144)	1	2134 003	2134 003			
	(code 148)	1	2134 004	2134 004			
	(code 151)	1	----	2434 034			
	(code 251)	1	----	2434 076			
	(code 153)	1	----	2434 035			
	(code 253)	1	----	2434 077			
	(code 231)	1	----	2134 884	2134 890		
	(3rd seat)	1	----	----	2134 894		
	(code 233)	1	----	----	2134 159		
	(2nd seat)	1	----	----	2134 171		
	(code 235)	1	----	2134 140	2134 160		
	(3rd seat)	1	----	----	2134 172		
	(3rd seat)	1	----	----	2134 173		
	Y1-L						
	(code 901)	1	----	2295 619	----	2295 657	
	(code 903)	1	----	2295 620	----	2295 658	
	(code 904)	1	----	2295 621	----	2295 659	
	(code 908)	1	----	2295 622	----	2295 660	
	(code 909)	1	----	2295 623	----	2295 661	
	Y1-M						
	(code 921)	1	----	2295 630	----	2295 668	
	(code 923)	1	----	2295 631	----	2295 669	
	(code 924)	1	----	2295 632	----	2295 670	
	(code 925)	1	----	2295 633	----	2295 671	
	(code 928)	1	----	2295 634	----	2295 672	
	(code 929)	1	----	2295 635	----	2295 673	

★ Indicates use as required.

☐ Indicates parts not listed in any previous parts book.

Jan. 3, 1964 Supersedes Jan. 25, 1963.

Printed in U.S.A.

Prices and specifications subject to change without notice.

Right and left part numbers are on same line,

first number is right, second number is left.

* Indicates change or addition.

CODE	REMARKS	PER CAR	SED.	SP. 4 D.	SUB.	SP. CL. CP.	CV. CP.
23-109-35	CUSHION, Rear Seat - Cont'd						
	Y1-M						
	(code 939)	1	----	2430 372	----	2430 373	
	(code 951)	1	----	2295 640	----	2295 678	2295 701
	(code 955)	1	----	2295 641	----	2295 679	2295 702
	(code 956)	1	----	2295 642	----	2295 680	2295 703
	(code 957)	1	----	2295 643	----	2295 681	2295 704
	Y1-H						
	(code 941)	1	----	2295 648			
	(code 943)	1	----	2295 649			
	(code 944)	1	----	2295 650			
	(code 949)	1	----	2295 651			
	(code 975)	1	----	2295 641			
	(code 976)	1	----	2295 642			
	(code 977)	1	----	2295 643			
23-109-36	COVER, Rear Seat Cushion						
	C1-L						
	(code 101)	1	2133 087				
	(code 102)	1	2133 088				
	(code 103)	1	2133 089				
	(code 105)	1	2133 090				
	(code 108)	1	2133 091				
	(code 104) (police)	1	2133 080				
	(code 204) (police)	1	2133 599				
	(code 111)	1	----	2133 242	----	2133 354	
	(code 112)	1	----	2133 243	----	2133 355	
	(code 113)	1	----	2133 244	----	2133 356	
	(code 115)	1	----	2133 245	2134 715	2133 357	
	(code 201) (2nd seat)	1	----	2134 699	2134 715	2134 753	2134 780
	(code 201) (3rd seat)	1	----	----	2134 722		
	(code 203) (2nd seat)	1	----	----	2133 485	----	2134 781
	(code 203) (3rd seat)	1	----	----	2133 509		
	(code 205) (2nd seat)	1	----	2133 453	2133 486	2133 555	2133 570
	(code 205) (3rd seat)	1	----	----	2133 510		
	(code 206) (2nd seat)	1	----	2133 454	2133 487	2133 556	2133 571
	(code 206) (3rd seat)	1	----	----	2133 511		
	(code 208)	1	----	2133 455	----	2133 557	2133 572
	C2-M						
	(code 121)	1	----	2134 662			
	(code 123)	1	----	2133 862			
	(code 125)	1	----	2133 863			
	(code 126)	1	----	2133 864			
	(code 221)	1	----	2134 821	----	2134 837	2134 849
	(code 223)	1	----	2133 687	----	2134 585	2134 595
	(code 225)	1	----	2133 688	----	2134 586	2134 596
	(code 227)	1	----	2133 690	----	2134 588	2134 598
	(code 228)	1	----	2133 691	----	2134 589	2134 599
	(code 245)	1	----	2134 932	----	2134 941	2134 939
	C3-H						
	(code 141)	1	2134 005	2134 005			
	(code 142)	1	2134 006	2134 006			
	(code 143)	1	2134 007	2134 007			
	(code 144)	1	*2134 008	*2134 008			
	(codes 145, 148)	1	*2134 009	*2134 009			
	(code 151)	1	----	2434 036			
	(code 251)	1	----	2434 078			
	(code 153)	1	----	2434 037			
	(code 253)	1	----	2434 079			
	(code 231) (2nd seat)	1	----	2134 885	2134 891		
	(code 231) (3rd seat)	1	----	----	2134 895		

★ Indicates use as required.

☐ Indicates parts not listed in any previous parts book.

Right and left part numbers are on same line, first number is right, second number is left.

* Indicates change or addition.

Printed in U.S.A.
Prices and specifications subject to change without notice.
Jan. 3, 1964 Supersedes Jan. 25, 1963.

1963 PASSENGER CAR PARTS CATALOG

INTERIOR TRIM

CODE	REMARKS	PER CAR	SED.	SP. 4 D.	SUB.	SP. CL. CP.	CV. CP.
23-109-36	COVER, Rear Seat Cushion - Cont'd C3-H						
	(code 233) (2nd seat)	1	----	----	2134 162		
	(code 233) (3rd seat)	1	----	----	2134 174		
	(code 235) (2nd seat)	1	----	2134 143	2134 163		
	(code 235) (3rd seat)	1	----	----	2134 175		
	(code 236) (2nd seat)	1	----	2134 144	2134 164		
	(code 236) (3rd seat)	1	----	----	2134 176		
	C3-H (body cloth)						
	(code 141)	1	⊠2434 329	⊠2434 329			
	(code 143)	1	⊠2434 330	⊠2434 330			
	(code 148)	1	⊠2434 331	⊠2434 331			
	Y1-L						
	(code 901)	1	----	2295 614	----	2295 652	
	(code 903)	1	----	2295 615	----	2295 653	
	(code 904)	1	----	2295 616	----	2295 654	
	(code 908)	1	----	2295 617	----	2295 655	
	(code 909)	1	----	2295 618	----	2295 656	
	Y1-M						
	(code 921)	1	----	2295 624	----	2295 662	
	(code 923)	1	----	2295 625	----	2295 663	
	(code 924)	1	----	2295 626	----	2295 664	
	(code 925)	1	----	2295 627	----	2295 665	
	(code 928)	1	----	2295 628	----	2295 666	
	(code 929)	1	----	2295 629	----	2295 667	
	(code 939)	1	----	2430 378	----	2430 379	
	(code 951)	1	----	2295 636	----	2295 674	2295 697
	(code 955)	1	----	2295 637	----	2295 675	2295 698
	(code 956)	1	----	2295 638	----	2295 676	2295 699
	(code 957)	1	----	2295 639	----	2295 677	2295 700
	Y1-H						
	(code 941)	1	----	2295 644	----		
	(code 943)	1	----	2295 645	----		
	(code 944)	1	----	2295 646	----		
	(code 949)	1	----	2295 647	----		
	(code 975)	1	----	2295 637	----		
	(code 976)	1	----	*2295 638	----		
	(code 977)	1	----	2295 639	----		
23-109-38	RETAINER, Center Floor Pan Rear Seat Cushion C1, C2, C3, Y1	2	1810 037	1810 037	----	1810 037	1810 037
23-109-40	INSERT, Rear Seat Cushion Bottom Panel C1-L						
	(code 201) (blue)	1	----	----	2180 833		
	(codes 203, 206) (black)	1	----	----	*1817 TX8		
	(code 205) (red)	1	----	----	2179 516		
	C3-H						
	(code 231) (blue)	1	----	----	2180 872		
	(code 233) (tan)	1	----	----	2179 496		
	(code 235) (red)	1	----	----	2179 497		
	(code 236) (black)	1	----	----	2179 498		
23-111-10	STRIP, Front Pillar Upper Tacking Y1	2	----	1878 174	----	1878 174	1878 174

★ Indicates use as required.

⊠ Indicates parts not listed in any previous parts book.
Jan. 3, 1964 Supersedes Jan. 25, 1963.

Printed in U.S.A.

Prices and specifications subject to change without notice.
Right and left part numbers are on same line,
first number is right, second number is left.
* Indicates change or addition.

CODE	REMARKS	PER CAR	SED.	SP. 4 D.	SUB.	SP. CL. CP.	CV. CP.
23-111-30	STRIP, Folding Top Header Tacking						
	Y1 (side)	2	----	----	----	----	1691 923
	(front)	1	----	----	----	----	1750 628
23-111-31	RETAINER, Folding Top Header Outer Panel						
	C1, C2	1	----	----	----	----	1952 194
23-111-37	STRIP, Folding Top Bow						
	C1, C2 (No. 1 Bow)	2	----	----	----	----	1950 509
	(No. 2 Bow)	2	----	----	----	----	1950 509
	(rear Bow)	1	----	----	----	----	*2424 607
	Y1	4	----	----	----	----	1691 901
23-112-12	DUST BOOT, Folding Top						
	C1-L						
	(code 201) (blue)	1	----	----	----	----	E2182 062
	(code 203) (tan)	1	----	----	----	----	E2182 063
	(code 205) (red)	1	----	----	----	----	E2182 064
	(code 206) (alabaster)	1	----	----	----	----	E2182 065
	(code 208) (turquoise)	1	----	----	----	----	2180 905
	C2-M						
	(code 221) (blue)	1	----	----	----	----	E2182 067
	(code 223) (tan)	1	----	----	----	----	E2182 063
	(code 225) (red)	1	----	----	----	----	E2182 064
	(code 227) (alabaster)	1	----	----	----	----	E2182 065
(code 228) (turquoise)	1	----	----	----	----	2180 907	
(code 245) (red)	1	----	----	----	----	E2182 064	
Y1-M							
(code 951) (blue)	1	----	----	----	----	----	E2181 809
(code 955) (red)	1	----	----	----	----	----	E2181 810
(code 956) (charcoal)	1	----	----	----	----	----	E2181 811
(code 957) (alabaster)	1	----	----	----	----	----	E2181 812
(attaching fastener)	2	----	----	----	----	----	2094 394
(cap, fastener)	*	----	----	----	----	----	6000 434
23-112-18	RETAINER, Rear Seat Back						
	Dust Boot Channel						
	C1, C2	1	----	----	----	----	2270 929
	Y1	1	----	----	----	----	2410 046
23-112-45	CURTAIN, Folding Top Rear						
	C1, C2						
	(up to serial No. 231593)						
	(blue)	1	----	----	----	----	*2180 943
	(after) (blue)	1	----	----	----	----	E2182 289
	(up to serial No. 224502)						
	(black)	1	----	----	----	----	*2180 944
	(after) (black)	1	----	----	----	----	E2182 297
	(up to serial No. 223156)						
	(white)	1	----	----	----	----	*2180 945
	(after) (white)	1	----	----	----	----	E2182 263
	(up to serial No. 218445)						
(alabaster)	1	----	----	----	----	E2182 318	
(after) (alabaster)	1	----	----	----	----	E2182 369	
Screw (to rear rail)	2	----	----	----	----	E9414 742	
(back light) (black)	1	----	----	----	----	2180 985	
Y1 (white)	1	----	----	----	----	2177 530	
(black)	1	----	----	----	----	2180 365	
(cap fastener)	1	----	----	----	----	6000 434	
(socket)	1	----	----	----	----	141 998	

★ Indicates use as required.

3 Indicates parts not listed in any previous parts book.

Right and left part numbers are on same line,

first number is right, second number is left.

* Indicates change or addition.

Printed in U.S.A.
Prices and specifications subject to change without notice.

Jan. 3, 1964 Supersedes Dec. 14, 1962.

CODE	REMARKS	PER CAR	SED.	SP. 4 D.	SUB.	SP. CL. CP.	CV. CP.
23-112-46	ZIPPER, Folding Top Rear Curtain (alabaster)	1	----	----	----	----	⊖2182 314
	C1, C2 (black)	1	----	----	----	----	2180 947
	Y1 (black)	1	----	----	----	----	⊖2172 107
23-112-50	TAPE, Folding Top Back Curtain Side Closure Loop (sold by the inch)						
	C1, C2 (black) (quarter stay closure hook)	★	----	----	----	----	*1933 TX8
	(black)	★	----	----	----	----	*1934 TX8
23-112-70	RETAINER, Folding Top to Belt Bar C1, C2 (center)	1	----	----	----	----	2243 924
	(side)	1	----	----	----	----	2243 922-3
	(side rear)	1	----	----	----	----	2244 426-7
	(end)	1	----	----	----	----	2424 348
	(inner)	1	----	----	----	----	2216 421
	Y1-M	2	----	----	----	----	2094 354
		1	----	----	----	----	1877 746-7
23-112-75	TIP, Folding Top Wire-on Bending End C1, C2, Y1-M	1	----	----	----	----	1158 976-7
23-112-88	CABLE, Folding Top Rear Bow Tension C1, C2 (white)	2	----	----	----	----	*2166 659
	(black)	2	----	----	----	----	*2480 819
	(side front cover)	2	----	----	----	----	*2490 182
	Y1	2	----	----	----	----	2166 660
	Y1-M (side front cover)	2	----	----	----	----	⊖2490 183
23-112-96	SPACER, Folding Top Side Rear Rail Tension Cable and Spring Y1-M	2	----	----	----	----	⊖2490 289
	Screw (spring attaching)	2	----	----	----	----	⊖9414 742
23-112-108	DECK and SIDE QUARTER, Folding Top C1, C2 (alabaster)	1	----	----	----	----	⊖2182 313
	(blue)	1	----	----	----	----	2180 937
	(black)	1	----	----	----	----	2180 938
	(white)	1	----	----	----	----	2180 939
	Y1-M (black)	1	----	----	----	----	2180 354
	(white)	1	----	----	----	----	2177 534
	(screw)(deck to front header)	2	----	----	----	----	6000 238
23-112-112	PAD, Folding Top Side Quarter Stay C1, C2 (alabaster)	1	----	----	----	----	⊖2182 316-17
	(black)	1	----	----	----	----	2180 940-1
	Y1 (black)	1	----	----	----	----	2180 728-9
23-112-153	WELL, Pocket Panel, Pocket Panel Cover, Pocket Shelf Panel, Folding Top C1-L, C2-M (pocket shelf panel)						
	(code 201) (blue)	1	----	----	----	----	2134 576-7
	(code 221) (blue)	1	----	----	----	----	2133 788-9
	(codes 203, 223) (tan)	1	----	----	----	----	2133 790-1
	(codes 205, 225) (red)	1	----	----	----	----	2133 792-3

★ Indicates use as required.

⊖ Indicates parts not listed in any previous parts book.

Jan. 3, 1964 Supersedes Sept. 4, 1962.

Printed in U.S.A.
Prices and specifications subject to change without notice.Right and left part numbers are on same line,
first number is right, second number is left.

* Indicates change or addition.

CODE	REMARKS	PER CAR	SED.	SP. 4 D.	SUB.	SP. CL. CP.	CV. CP.
23-112-153	WELL, Pocket Panel, Pocket Panel Cover, Pocket Shelf Panel, Folding Top - Cont'd						
	C1-L, C2-M						
	(codes 206, 227) (black)	1	----	----	----	----	2133 794-5
	(code 208) (turquoise)	1	----	----	----	----	2134 578-9
	(code 228) (turquoise)	1	----	----	----	----	2133 796-7
	C1-L (pocket panel)						
	(code 201)	1	----	----	----	----	2134 980-1
	(code 203)	1	----	----	----	----	2133 810-1
	(code 205)	1	----	----	----	----	2133 812-3
	(code 206)	1	----	----	----	----	2133 814-5
	(code 208)	1	----	----	----	----	2134 982-3
	(pocket panel cover)						
	(code 201)	1	----	----	----	----	2134 984-5
	(code 203)	1	----	----	----	----	2133 820-1
	(code 205)	1	----	----	----	----	2133 823-4
	(code 206)	1	----	----	----	----	2133 825-6
	(code 208)	1	----	----	----	----	2134 986-7
	C2-M (pocket panel)						
	(code 221)	1	----	----	----	----	2133 808-9
	(code 223)	1	----	----	----	----	2133 810-1
	(codes 225, 245)	1	----	----	----	----	2133 812-3
	(code 227)	1	----	----	----	----	2133 814-5
	(code 228)	1	----	----	----	----	2133 816-7
	(pocket panel cover)						
	(code 221)	1	----	----	----	----	2133 818-9
	(code 223)	1	----	----	----	----	2133 820-1
	(codes 225, 245)	1	----	----	----	----	2133 822-3
	(code 227)	1	----	----	----	----	2133 824-5
	(code 228)	1	----	----	----	----	2133 826-7
	C1-L						
	(folding top well)						
	(code 201) (blue)	1	----	----	----	----	2180 892
	(code 203) (tan)	1	----	----	----	----	2180 893
	(code 205) (red)	1	----	----	----	----	2180 894
	(code 206) (alabaster)	1	----	----	----	----	2180 895
	(code 208) (turquoise)	1	----	----	----	----	2180 896
	C2-M						
	(folding top well)						
	(code 221) (blue)	1	----	----	----	----	2180 897
	(code 223) (tan)	1	----	----	----	----	2180 893
	(code 225) (red)	1	----	----	----	----	2180 894
	(code 227) (alabaster)	1	----	----	----	----	2180 895
	(code 228) (turquoise)	1	----	----	----	----	2180 898
	(code 245) (red)	1	----	----	----	----	2180 894
	(well cover fastener cap)	★	----	----	----	----	6000 434
	Y1-M						
	(folding top well)						
	(code 951) (blue)	1	----	----	----	----	2180 356
	(code 955) (red)	1	----	----	----	----	2180 357
	(code 956) (charcoal)	1	----	----	----	----	2180 358
	(code 957) (alabaster)	1	----	----	----	----	2180 359
	(well cover fastener cap)	★	----	----	----	----	6000 434
	Y1-M (pocket panel)						
	(code 951)	1	----	----	----	----	2295 452-3
	(code 955)	1	----	----	----	----	2295 454-5
	(code 956)	1	----	----	----	----	2295 456-7
	(code 957)	1	----	----	----	----	2295 458-9
	(fastener, to dust boot)	2	----	----	----	----	2094 380

★ Indicates use as required.
 ☐ Indicates parts not listed in any previous parts book.
 Right and left part numbers are on same line,
 first number is right, second number is left.
 * Indicates change or addition.

1963 PASSENGER CAR PARTS CATALOG

CODE	REMARKS	PER CAR	SED.	SP. 4 D.	SUB.	SP. CL. CP.	CV. CP.
23-112-153	WELL, Pocket Panel, Pocket Panel Cover, Pocket Shelf Panel, Folding Top - Cont'd Y1-M (pocket panel cover)						
	(code 951)	1	----	----	----	----	2295 444-5
	(code 955)	1	----	----	----	----	2295 446-7
	(code 956)	1	----	----	----	----	2295 448-9
	(code 957)	1	----	----	----	----	2295 450-1
23-113-2	WEATHERCORD, Door C1, C2, C3 (sold by the inch) (codes 101, 111, 121, 141, 201, 221, 231) (blue) (codes 102, 112, 142) (green) (codes 103, 113, 123, 143, 203, 223, 233) (tan) (codes 104, 204, 206, 236) (black) (codes 105, 115, 125, 205, 225, 235, 245) (red) (codes 126, 206, 227) (alabaster) (codes 108, 148, 208, 228) (turquoise) (code 144) (gray) (codes 151, 251) (blue) (codes 153, 253) (beige)						
	★	★	2182 165	2182 165	2182 165	2182 165	2182 165
	★	★	2182 166	2182 166	2182 166	2182 166	2182 166
	★	★	2182 167	2182 167	2182 167	2182 167	2182 167
	★	★	2182 164	2182 164	2182 164	2182 164	2182 164
	★	★	2182 168	2182 168	2182 168	2182 168	2182 168
	★	★	2182 170	2182 170	2182 170	2182 170	2182 170
	★	★	2182 169	2182 169	2182 169	2182 169	2182 169
	★	★	2182 171	2182 171			
	★	★	----	2182 177			
	★	★	----	2182 178			
NOTE: For Chrysler Hinge Pillar and Lock Pillar Weathercords see Part Type Code 23-113-2.							
NOTE: For Rear Door Hinge Pillar Weathercord for Imperial Sp. 4 D., see Part Type Code 23-99-41.							
23-113-25	WEATHERCORD, Front Door Hinge Pillar Y1 (codes 901, 921, 941, 951) (blue) (codes 903, 923, 943) (tan) (codes 904, 924, 944) (gray) (codes 908, 928) (turquoise) (codes 909, 929, 939, 949) (gold) (codes 925, 955, 975) (red) (code 956) (charcoal) (codes 957, 976, 977) (alabaster)						
	2	2	----	2179 702	----	2179 702	2179 702
	2	2	----	2179 703	----	2179 703	
	2	2	----	2179 704	----	2179 704	
	2	2	----	2179 705	----	2179 705	
	2	2	----	2179 706	----	2179 706	
	2	2	----	2179 707	----	2179 707	2179 707
	2	2	----	2179 708	----	2179 708	2179 708
	2	2	----	2179 709	----	2179 709	2179 709
23-113-30	WEATHERCORD, Door Lock Pillar Y1 (codes 901, 921, 951) (blue) (codes 903, 923) (tan) (codes 904, 924) (gray) (codes 908, 928) (turquoise) (codes 909, 929, 939) (gold) (codes 925, 955) (red) (code 956) (charcoal) (code 977) (alabaster)						
	2	2	----	----	----	2179 608	2179 608
	2	2	----	----	----	2179 609	2179 609
	2	2	----	----	----	2179 610	
	2	2	----	----	----	2179 611	
	2	2	----	----	----	2179 612	
	2	2	----	----	----	2179 613	2179 613
	2	2	----	----	----	2179 614	2179 614
	2	2	----	----	----	2179 615	2179 615
23-113-36	FILLER, Folding Top Front Bow Y1	1	----	----	----	----	1246 543
23-113-50	WELT, Windshield Side Garnish Moulding to Instrument Panel C1, C2, C3 (paint as required)	2	1758 241	1758 241	1758 241	1758 241	1758 241

★ Indicates use as required.

⊠ Indicates parts not listed in any previous parts book.

Jan. 3, 1964 Supersedes Dec. 14, 1962.

Printed in U.S.A.

Prices and specifications subject to change without notice.

Right and left part numbers are on same line,

first number is right, second number is left.

* Indicates change or addition.

CODE	REMARKS	PER CAR	SED.	SP. 4 D.	SUB.	SP. CL. CP.	CV. CP.
23-113-50	WELT, Windshield Side Garnish Moulding to Instrument Panel - Cont'd Y1 (paint as required) (gray)	1	----	2180 666-7	----	2180 666-7	2180 666-7
23-113-84	WELT, Folding Top Header C1, C2 (black) (alabaster) Y1 (black)	2 2 1	----	----	----	----	2179 386 E2182 320 2192 739
23-114-2	MATERIAL, Seat Cloth Trim C1-L (54" wide) (code 101) (blue) (code 102) (green) (code 103) (tan) (code 105) (red) (code 108) (turquoise) (code 104) (gray)	★ ★ ★ ★ ★ ★	2185 906 2185 907 2185 908 2185 909 2185 910 2186 238				
	C2-M (70" wide) (code 121) (blue) (code 123) (tan) (code 125) (red) (code 126) (black)	★ ★ ★ ★	---- 2186 187 2185 917 2185 918 2185 919				
	C3-H (58" wide) (code 141) (blue) (code 142) (green) (code 143) (tan) (code 144) (gray) (code 148) (turquoise) (code 151) (blue) (code 153) (beige)	★ ★ ★ ★ ★ ★ ★	2185 924 2185 925 2185 926 2185 927 2185 928 2186 294 2186 295	2185 924 2185 925 2185 926 2185 927 2185 928			
23-114-10	BINDING (5/8" wire on) C1, C2, Y1-M (paint as required) (white) (black) (blue) (alabaster)	1 1 1 1	----	----	----	----	2177 529 E2181 851 E2180 948 E2182 319
23-114-14	HIDE, Leather C2-M (code 245) (codes 151, 251) (blue) (codes 153, 253) (beige)	★ ★ ★	---- 2185 966 2186 300 2186 301	2185 966	----	2185 966	2185 966
	Y1-M, Y1-H (codes 921, 941, 951) (blue) (codes 923, 943) (tan) (codes 924, 944) (gray) (codes 925, 955, 975) (red) (code 928) (turquoise) (codes 929, 939) (gold) (code 956) (charcoal) (codes 957, 976, 977) (alabaster)	★ ★ ★ ★ ★ ★ ★ ★	---- 2185 963 2185 964 2185 965 *2185 966 2185 967 2185 968 2186 041 2186 040	2185 963 2185 964 2185 965 2185 966 2185 967 2185 968 2186 041 2186 040	----	2185 963 2185 964 2185 965 *2185 966 2185 967 2185 968 2186 041 2186 040	2185 963 2185 964 2185 965 *2185 966 2185 967 2185 968 2186 041 2186 040
23-114-15	MATERIAL, Leather (imitation) C1-L, C2-M, C3-H (codes 101, 111, 141) (28A-AM-22)(50") (1602 blue) (code 111) (1601 blue) (28-AM-22)(50") (1601 blue)	★ ★ ★	2185 647 ---- 2185 615	2185 647 2185 615 2185 615	----	2185 647 2185 615	

★ Indicates use as required.

□ Indicates parts not listed in any previous parts book.

Right and left part numbers are on same line, first number is right, second number is left.

* Indicates change or addition.

Printed in U.S.A.
Prices and specifications subject to change without notice.
Jan. 3, 1964 Supersedes Jan. 25, 1963.

1963 PASSENGER CAR PARTS CATALOG

INTERIOR TRIM

CODE	REMARKS	PER CAR	SED.	SP. 4D.	SUB.	SP. CL. CP.	CV. CP.
23-114-15 MATERIAL, Leather (imitation) - Cont'd							
C1-L, C2-M, C3-H							
	(code 111) (1600 blue)	★	----	2185 778	----	2185 778	
	(19A-C-22)(54") (1602 blue)	★	2185 625				
	(1602 blue)	★	----	2185 620	----	2185 620	
	(19A-DJ-22)(54") (1601 blue)	★	2185 798				
	(1600 blue)	★	----	2186 097	----	2186 097	
	(19B-C-22)(54") (1601 blue)	★	2185 620	2185 620			
	(19C-C-22) (54") (1602 blue)	★	2185 625				
	(1601 blue)	★	----	2185 620	----	2185 620	
	(19-C-22) (54") (1601 blue)	★	2185 620				
	(code 141) (1602 blue)	★	2185 625	2185 625			
	(code 101) (1600 blue)	★	2186 097				
	(1602 blue)	★	2185 798	2185 798	----	2185 798	
	(codes 151, 251) (38-DZ-22)						
	(54") (1691-1 blue)	★	----	2186 296			
	(codes 153, 253)						
	(38-DZ-22) (54")						
	(1690-1 blue)	★	----	2186 302			
C1, C2, C3							
	(codes 121, 221, 231)						
	(19-C-22) (54") (1680 blue)	★	----	*2186 191	----	*2186 191	*2186 191
	(19A-DJ-22) (54") (1602 blue)	★	----	⊕2185 761	----	⊕2185 761	⊕2185 761
	(28-AM-22) (50") (1680 blue)	★	----	2186 190	⊕2185 778	2186 190	2186 190
	(34-DV-78) (45) (1678 blue)	★	----	2186 184	----	2186 184	2186 184
	(codes 102, 112, 142)						
	(28-AM-22) (50") (1604 green)	★	2185 616	2185 616	----	2185 616	
	(34-DV-78) (45")						
	(1649 turq. antique)	★	----	----	----	⊕2186 177	----
	(code 112) (1603 green)	★	----	2186 133	----	2186 133	
	(19A-C-22) (54") (1605 green)	★	2185 626				
	(code 112) (1604 green)	★	----	2185 621	----	2185 621	
	(19A-DJ-22) (54") (1604 green)	★	2185 799				
	(code 112) (1603 green)	★	----	2186 136	----	2186 136	
	(19B-C-22) (54") (1604 green)	★	----	2185 621	----	2185 621	
	(19C-C-22) (54") (1605 green)	★	2185 626				
	(1604 green)	★	----	2185 621	----	2185 621	
C1-L, C3-H							
	(19-C-22) (54") (1604 green)	★	2185 621				
	(1603 green)	★	----	2185 737	----	2185 737	
	(code 142) (1605 green)	★	2185 626	2185 626			
	(1604 green)	★	2185 799	2185 799	----	2185 799	
C1-L, C2-M, C3-H							
	(codes 103, 113, 123, 143, 203, 223, 233)						
	(28A-AM-22) (50") (1608 tan)	★	2185 649				
	(1607 tan)	★	----	*2185 779	*2185 779	*2185 779	*2185 779
	(28-AM-22) (50") (1606 tan)	★	*2185 779	*2185 779	*2185 779		
	(codes 113, 123, 203, 223)						
	(1606 tan)	★	----	2185 622	2185 622	2185 622	2185 622
	(34-DY-78) (45") (1648 tan)	★	----	2186 176	2186 176	2186 176	2186 176
	(19A-C-22) (54") (1608 tan)	★	2185 627	2185 627			
	(codes 113, 123, 203, 223)						
	(1607 tan)	★	*2185 738	*2185 738	*2185 738	*2185 738	*2185 738
	(19A-DJ-22) (54") (1607 tan)	★	2185 800				
	(codes 113, 203) (1606 tan)	★	----	2186 098	2186 098	2186 098	2186 098
	(codes 123, 223) (1608 tan)	★	----	2185 672	----	2185 672	2185 672
	(19B-C-22) (54") (1608 tan)	★	----	2185 627	2185 627		
	(19C-C-22) (54") (1608 tan)	★	2185 627	2185 627	----	2185 627	2185 627
	(code 113) (1607 tan)	★	----	2185 622	----	2185 622	

★ Indicates use as required.

⊕ Indicates parts not listed in any previous parts book.

Jan. 3, 1964 Supersedes Jan. 25, 1963.

Prices and specifications subject to change without notice.

Right and left part numbers are on same line, first number is right, second number is left.

* Indicates change or addition.

Printed in U.S.A.

CODE	REMARKS	PER CAR	SED.	SP. 4 D.	SUB.	SP. CL. CP.	CV. CP.
23-114-15	MATERIAL, Leather (imitation) - Cont'd C1-L, C2-M, C3-H (codes 151, 251, 153, 253)						
	(37-DX-85) (54") (1624 black)	★	----	*2186 299			
	(37-DZ-22) (54") (1690-1 beige)	★	----	*2186 302			
	(code 203) (1516 white)	★	----	----	2185 329		
	(code 233) (1617 alabaster)	★	----	----	2185 631		
	(19-C-22) (54") (1607 tan)	★	2185 622	2185 622	2185 622		
	(codes 113, 123, 203, 223) (1605 tan)	★	----	2185 738	2185 738	2185 738	2185 738
	(code 143) (1608 tan)	★	2185 627	2185 627			
	(19-DJ-22) (54") (1607 tan)	★	2185 800	2185 800	2185 800	2185 800	2185 800
	(code 103) (1608 tan)	★	2185 762				
	(codes 123, 223) (1606 tan)	★	----	2186 098			
	(codes 104, 144, 204)						
	(37A-CX-22) (50") (1609 gray)	★	2186 095				
	(37-CX-22) (50") (1610 gray)	★	2186 094				
	(28A-AM-22) (50") (1610 gray)	★	2185 633				
	(28-AM-22) (50") (1609 gray)	★	2185 780				
	(code 144) (1610 gray)	★	2185 633	2185 633			
	(19A-C-22) (54") (1610 gray)	★	2185 834				
	(19A-DJ-22) (54") (1610 gray)	★	2185 835				
	(19B-C-22) (54") (1610 gray)	★	2185 834	2185 834			
	(code 144) (1624 black)	★	2185 632	2185 632			
	(19-DJ-22) (54") (1609 gray)	★	2186 083				
	(1610 gray)	★	2185 835	2185 835			
	(codes 105, 115, 125, 205, 225, 235) (28A-AM-22) (50")						
	(1616 red)	★	2185 650	2185 650	2185 650	2185 650	2185 650
	(28-AM-22) (50") (1615 red)	★	2185 618	2185 618	2185 618	2185 618	2185 618
	(25-DV-78) (45") (1652 red)	★	----	2186 180	2186 180	2186 180	2186 180
	(19A-C-22) (54") (1616 red)	★	2185 628	2185 628	2185 628	2185 628	2185 628
	(code 125) (1615-1 red)	★	2185 623				
	(code 225) (1615-1 red)	★	----	2185 623	----	2185 623	2185 623
	(19A-DJ-22) (54") (1616 red)	★	2185 809	2185 809	2185 809	2185 809	2185 809
	(19B-C-22) (54") (1615-1 red)	★	----	2185 623	2185 623		
	(19C-C-22) (54") (1615-1 red)	★	2185 623	2185 623	----	----	2185 623
	(code 235) (1617 alabaster)	★	----	2185 631	2185 631		
	(code 205) (1516 white)	★	*2185 329	2185 329	2185 329	2185 329	2185 329
	(19D-C-22) (54") (1615-1 red)	★	----	2185 623			
	(19-C-22) (54") (1615-1 red)	★	2185 623	2185 623	2185 623	2185 623	2185 623
	(19-DJ-22) (54") (1615-1 red)	★	2185 808	2185 808	2185 808	2185 808	2185 808
	(codes 126, 206, 236)						
	(28A-AM-22) (50") (1624 black)	★	----	2185 659	2185 659	2185 659	2185 659
	(28-AM-22) (50") (1617 alabaster)	★	----	2185 630	2185 630	2185 630	2185 630
	(codes 206, 236) (1624 black)	★	----	*2185 659	----	*2185 659	
	(25-DV-78) (45") (1651 gray)	★	----	2186 244	2186 244	2186 244	2186 244
	(19A-C-22) (54") (1624 black)	★	----	2185 632	2185 632	2185 632	2185 632
	(19A-DJ-22) (54") (1624 black)	★	----	2185 763	2185 763	2185 763	2185 763
	(19B-C-22) (54") (1624 black)	★	----	2185 632	2185 632		
	(19C-C-22) (54") (1516 white)	★	----	2185 329	2185 329	2185 329	2185 329
	(code 236) (1617 alabaster)	★	----	2185 631	2185 631		
	(19D-C-22) (54") (1617 alabaster)	★	----	2185 631			
	(code 226) (1624 black)	★	----	2185 632	----	2185 632	2185 632
	(19E-C-22) (54") (1624 black)	★	----	----	2185 632		
	(19F-C-22) (54") (1624 black)	★	----	2185 632	2185 632	2185 632	2185 632
	(19-C-22) (54") (1617 alabaster)	★	----	2185 631	2185 631	2185 631	2185 631

★ Indicates use as required.

⊔ Indicates parts not listed in any previous parts book.

Right and left part numbers are on same line,

first number is right, second number is left.

* Indicates change or addition.

Printed in U.S.A.

Prices and specifications subject to change without notice.

Jan. 3, 1964 Supersedes Dec. 14, 1962.

1963 PASSENGER CAR PARTS CATALOG

INTERIOR TRIM

CODE	REMARKS	PER CAR	SED.	SP. 4 D.	SUB.	SP. CL. CP.	CV. CP.
23-114-15	MATERIAL, Leather (imitation) - Cont'd C1-L, C2-M, C3-H						
	(code 236) (1624 black)	★	----	2185 632	2185 632		
	(19-D-J-22)(54") (1617 alabaster)	★	----	2185 802	2185 802	2185 802	2185 802
	(code 236) (1624 black)	★	----	2185 763	2185 763		
	C2-M (code 227) (28-AM-22)(54") (1617 alabaster)	★	----	*2185 630	----	*2185 630	*2185 630
	(25-DV-78)(45") (1650 alabaster)	★	----	2186 178	----	2186 178	2186 178
	(19A-C-22)(54") (1624 black)	★	----	2185 632	----	2185 632	2185 632
	(19A-DJ-22)(54") (1624 black)	★	----	2185 763	----	2185 763	2185 763
	(19C-C-22)(54") (1624 black)	★	----	2185 632	----	2185 632	2185 632
	(19D-C-22)(54") (1617 alabaster)	★	----	2185 631	----	2185 631	2185 631
	(19-C-22)(54") (1617 alabaster)	★	----	2185 631	----	2185 631	2185 631
	(19-DJ-22)(54") (1617 alabaster)	★	----	2185 802	----	2185 802	2185 802
	C1-L, C2-M, C3-H (codes 108, 148, 208, 228) (28A-AM-22)(50") (1613 turquoise)	★	2185 619	2185 619	2185 619	2185 619	2185 619
	(code 228) (1614 turquoise)	★	----	*2185 651	----	*2185 651	*2185 651
	(28-AM-22)(50") (1613 turquoise)	★	2185 619	2185 619			
	(code 208) (1612 turquoise)	★	----	2185 781	2185 781	2185 781	2185 781
	(25-DV-78)(45") (1649 turquoise)	★	----	2186 177	2186 177	2186 177	2186 177
	(19A-C-22)(54") (1613 turquoise)	★	----	2185 624	2185 624	2185 624	2185 624
	(codes 108, 228) (1614 turquoise)	★	2185 629	2185 629	----	2185 629	2185 629
	(19A-DJ-22) (54") (1612 turquoise)	★	----	2186 163	2186 163	2186 163	2186 163
	(1613 turquoise)	★	2185 806				
	(code 228) (1614 turquoise)	★	----	2185 807	----	2185 807	2185 807
	(19B-C-22)(54") (1613 turquoise)	★	2185 624	2185 624			
	(19C-C-22)(54") (1614 turquoise)	★	2185 629	2185 629	----	2185 629	2185 629
	(19D-C-22)(54") (1613 turquoise)	★	----	2185 624	----	2185 624	2185 624
	(19-C-22)(54") (1613 turquoise)	★	2185 624	2185 624	----	2185 624	2185 624
	(code 208) (1612 turquoise)	★	----	2185 739	2185 739	2185 739	2185 739
	(code 148) (1614 turquoise)	★	2185 629	2185 629			
	(19-DL-22) (54") (1614 turquoise)	★	2185 807				
	(codes 148, 208, 228) (1613 turquoise)	★	2185 806	2185 806	2185 806	2185 806	2185 806
	(codes 151, 153, 251, 253) (37-DX-85) (54")						
	(1624 black)	★	----	2136 299			
	Y1-L, Y1-M, Y1-H (codes 901, 921, 941, 951) (28-AM-22) (50") (1600 blue)	★	----	2185 778	----	2185 778	2185 778
	(22-AR-22) (54") (1600 blue)	★	----	2185 844	----	2185 844	2185 844
	(19A-C-22) (54") (1601 blue)	★	----	2185 620	----	2185 620	2185 620

★ Indicates use as required.

⊞ Indicates parts not listed in any previous parts book.

Jan. 3, 1964 Supersedes Sept. 4, 1962.

Printed in U.S.A.

Prices and specifications subject to change without notice.

Right and left part numbers are on same line,
first number is right, second number is left.

* Indicates change or addition.

CODE	REMARKS	PER CAR	SED.	SP. 4 D.	SUB.	SP. CL. CP.	CV. CP.
23-114-15	MATERIAL, Leather (imitation) Cont'd Y1-L, Y1-M, Y1-H						
	(code 901) (1602 blue)	★	----	2185 625			
	(19B-C-22) (54") (1600 blue)	★	----	2185 736	----	2185 736	2185 736
	(19-C-22) (54") (1600 blue)	★	----	2185 736	----	2185 736	2185 736
	(codes 903, 923, 943)						
	(28-AM-22) (54") (1606 tan)	★	----	2185 779	----	2185 779	
	(22-AR-22) (54") (1606 tan)	★	----	2185 845	----	2185 845	
	(19A-C-22) (54") (1608 tan)	★	----	2185 627	----	2185 627	
	(codes 923, 943) (1607 tan)	★	----	2185 622	----	2185 622	
	(19B-C-22) (54") (1606 tan)	★	----	2185 738	----	2185 738	
	(19-C-22) (54") (1606 tan)	★	----	2185 738	----	2185 738	
	(code 924) (1609 gray)	★	----	2185 780	----	2185 780	
	(22-AR-22) (54") (1606 tan)	★	----	2185 846	----	2185 846	
	(19A-C-22) (54") (1611 gray)	★	----	2185 849	----	2185 849	
	(codes 924, 944) (1609 gray)	★	----	2185 834	----	2185 834	
	(19B-C-22) (54") (1609 gray)	★	----	2185 740	----		
	(19-C-22) (54") (1609 gray)	★	----	2185 740	----	2185 740	
	(codes 925, 955, 975)						
	(28-AM-22) (50") (1615-1 red)	★	----	2185 618	----	2185 618	2185 618
	(22-AR-22) (54") (1615-1 red)	★	----	2185 861	----	2185 861	2185 861
	(19A-C-22) (54") (1615-1 red)	★	----	2185 623	----	2185 623	2185 623
	(19B-C-22) (54") (1615-1 red)	★	----	2185 623	----	2185 623	2185 623
	(19-C-22) (54") (1617 alabaster)	★	----	2185 631	----	2185 631	2185 631
	(codes 956, 976)						
	(28-AM-22) (50") (1623 charcoal)	★	----	2185 783	----	2185 783	2185 783
	(22-AR-22) (54") (1623 charcoal)	★	----	2185 923	----	2185 923	2185 923
	(19-C-22) (54") (1617 alabaster)	★	----	2185 631	----	2185 631	
	(codes 957, 977)						
	(28-AM-22) (50") (1617 alabaster)	★	----	2185 630	----	2185 630	2185 630
	(22-AR-22) (54") (1617 alabaster)	★	----	2185 921	----	2185 921	2185 921
	(19B-C-22) (54") (1617 alabaster)	★	----	2185 631	----	2185 631	2185 631
	(19-C-22) (54") (1617 alabaster)	★	----	2185 631	----	2185 631	
	(codes 908, 928)						
	(28-AM-22) (50") (1612 turquoise)	★	----	2185 781	----	2185 781	
	(22-AR-22) (54") (1612 turquoise)	★	----	2185 847	----	2185 847	
	(19A-C-22) (54") (1614 turquoise)	★	----	2185 629	----	2185 629	
	(code 928) (1612 turquoise)	★	----	2185 624	----	2185 624	
	(19B-C-22) (54") (1612 turquoise)	★	----	2185 739	----		
	(19-C-22) (54") (1612 turquoise)	★	----	2185 739	----	2185 739	
	(codes 909, 929, 939, 949)						
	(28-AM-22) (50") (1635 gold)	★	----	2185 782	----	2185 782	
	(22-AR-22) (54") (1635 gold)	★	----	2185 848	----	2185 848	
	(19A-C-22) (54") (1636 gold)	★	----	2185 850	----	2185 850	
	(19B-C-22) (54") (1635 gold)	★	----	2185 843	----		
	(19-C-22) (54") (1635 gold)	★	----	2185 843	----	2185 843	

★ Indicates use as required.

□ Indicates parts not listed in any previous parts book.

Right and left part numbers are on same line,

first number is right, second number is left.

* Indicates change or addition.

Printed in U.S.A.

Prices and specifications subject to change without notice.

Jan. 3, 1964 Supersedes Dec. 14, 1962.

1963 PASSENGER CAR PARTS CATALOG

INTERIOR TRIM

CODE	REMARKS	PER CAR	SED.	SP. 4 D.	SUB.	SP. CL. CP.	CV. CP.
23-115-4	NUT, Front Seat Back to Cushion Mounting C2, C3	4	----	2410 102	2410 102	2410 102	2410 102
23-115-5	WASHER, Front Seat Center Arm Rest C2, C3, Y1	2	----	1918 299	1918 299	1918 299	1918 299
23-115-6	PIN, Front Seat Back to Cushion Mounting C2, C3	4	----	2410 054	2410 054	2410 054	2410 054
23-115-10	SCREW, Front Seat Center Arm Rest to Center Cushion C2, C3, Y1	2	----	2092 212	2092 212	2092 212	2092 212

NOTES

★ Indicates use as required.
 ☒ Indicates parts not listed in any previous parts book.
 Jan. 3, 1964 Supersedes Sept. 4, 1962.

Printed in U.S.A.
 Prices and specifications subject to change without notice.
 Right and left part numbers are on same line,
 first number is right, second number is left.
 * Indicates change or addition.