

GROUP 10
ENGINE OILING SYSTEM
CONTENTS

	Page
Engine Oil Pan.....	2
Oil Filter.....	4
Oil Pump.....	2

ENGINE LUBRICATION

Pump Type.....		Rotor Full Pressure
Capacity (quarts).....		5*
Pump Drive.....		Camshaft
Operating Pressure at 40 to 50 mph.....		45 to 65 lbs.
Pressure Drop Resulting from Clogged Filter.....		7 to 9 psi
Oil Filter Type.....		Full Flow

*When Filter is Replaced, Add 1 Quart.

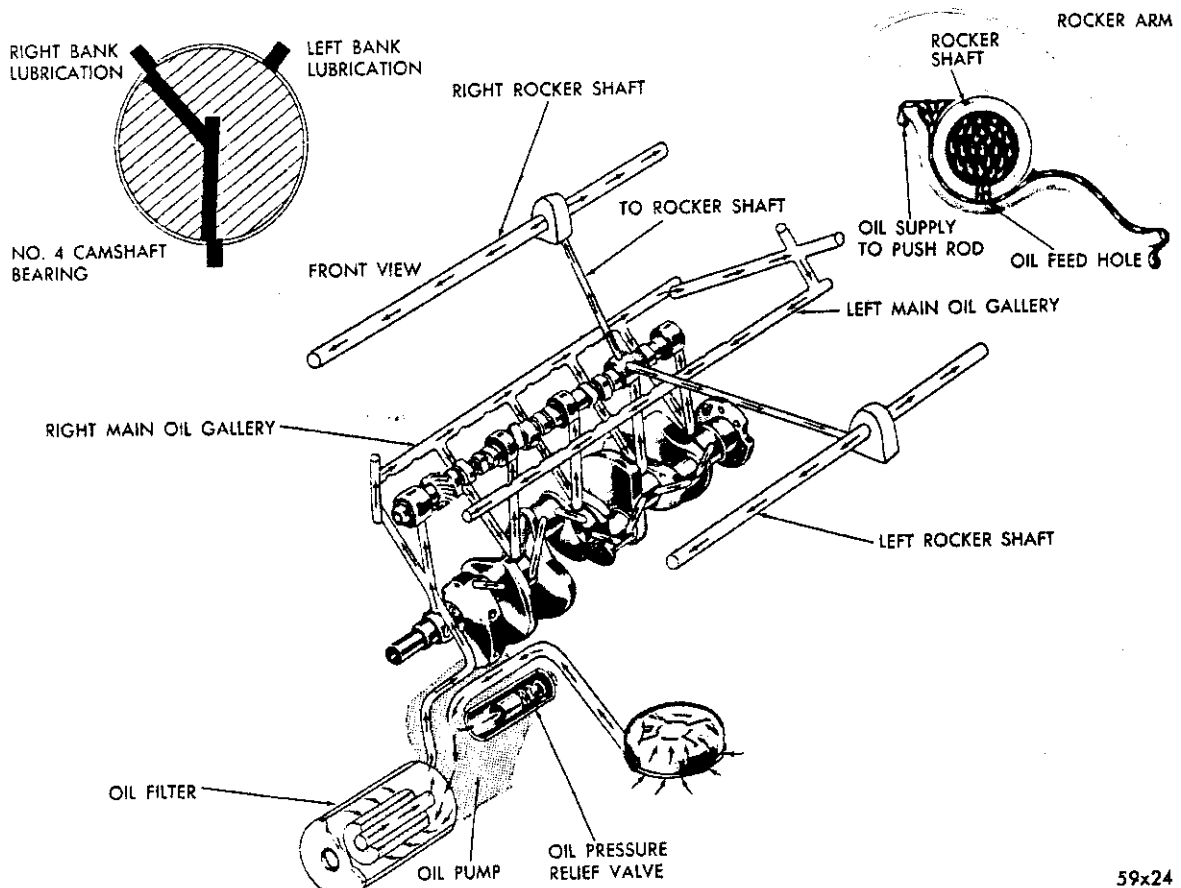

Fig. 1—Engine Oiling System (Schematic Drawing)

59x24

GROUP 10

ENGINE OILING SYSTEM

The engine oiling system consists of an externally mounted rotor type oil pump, a full flow oil filter, oil pan and the necessary lubrication passages. Oil is

forced by the oil pump through the filter to a series of oil passages in the engine, as shown in Figure 1.

SERVICE PROCEDURES

ENGINE OIL PAN

a. Removal

- (1) Disconnect the battery cable.
- (2) Raise car on hoist and disconnect the steering linkage from idler arm and pitman arm.
- (3) Remove the outlet vent pipe and disconnect the exhaust pipe branches from the right and left manifolds.
- (4) Remove the clamp attaching exhaust pipe to extension and remove the exhaust pipe.
- (5) Drain the crankcase oil.
- (6) Remove the converter dust shield.
- (7) Remove the oil pan bolts. Turn the flywheel until the counterweight and connecting rods at the front end of crankshaft are at their highest position to provide clearance, and lower the pan. Turn the pan counter-clockwise to clear the oil screen and suction pipe as it is lowered.

b. Installation

- (1) Check the alignment of the oil strainer. The bottom of the strainer must be on a horizontal plane with machined surface of cylinder block. The foot of the strainer should touch the bottom of the oil pan.
- (2) Install the oil pan.
- (3) Install the converter dust shield.
- (4) Connect the exhaust pipe branches to manifolds and to the exhaust extension and install outlet vent pipe.

- (5) Connect the steering linkage at the idler arm and at the pitman arm.

- (6) Connect the battery cable.

- (7) Install the drain plug and refill the crankcase.

OIL PUMP

a. Removal

Remove the oil pump attaching bolts and remove the pump and the filter assembly from the bottom side of the engine.

b. Disassembly

- (1) Remove the filter base and oil seal ring.
- (2) Remove the pump rotor and shaft and lift out the outer pump rotor.

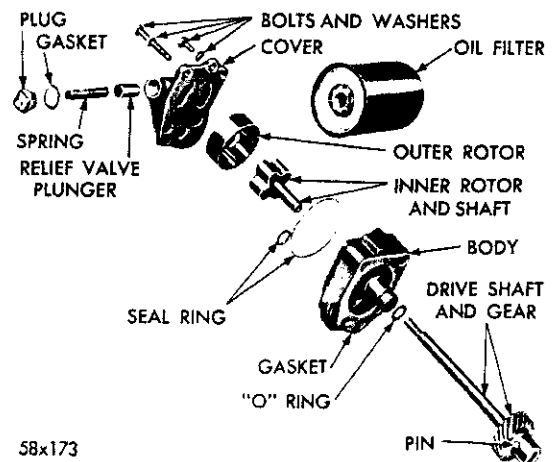

58x173

Fig. 2—Oil Pump and Filter Assembly (Disassembled)

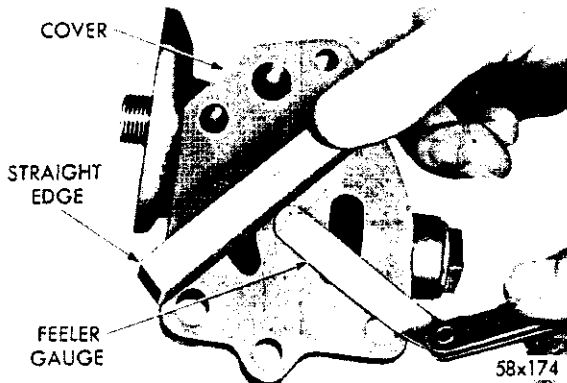

Fig. 3—Checking the Oil Pump Cover with a Straightedge

(3) Remove the oil pressure relief valve plug and lift out spring and relief valve plunger (Fig. 2).

c. Inspection

(1) Clean all the parts thoroughly. The mating face of the filter base (oil pump cover) should be smooth. Replace the filter base if it is scratched or grooved.

(2) Lay a straightedge across the oil pump filter base surface (Fig. 3). If a .0015 inch feeler gauge can be inserted between the base and the straightedge, the filter base should be replaced.

(3) If the outer rotor length measures less than .943 inch (Fig. 4) and the diameter less than 2.469 inches, replace the outer rotor.

(4) If the inner rotor length measures less than .943 inch (Fig. 5), a new inner rotor should be installed.

(5) Slide the outer rotor and inner rotor into the

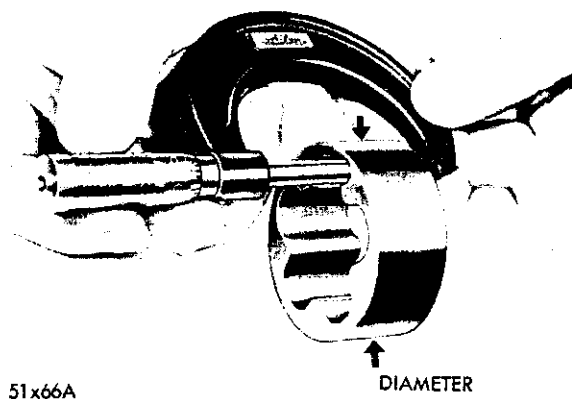

Fig. 4—Measuring the Outer Rotor Thickness

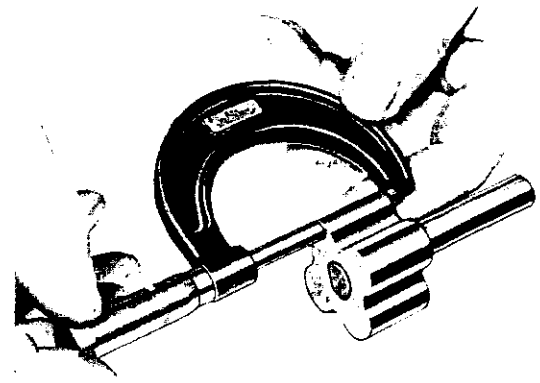

Fig. 5—Measuring the Inner Rotor Thickness

pump body and place a straightedge across the face (Between the bolt holes), as shown in Figure 6.

(6) If a feeler gauge of more than .004 inch can be inserted between the rotor and straightedge replace the rotor.

(7) Remove the inner rotor and shaft leaving the outer rotor in the pump cavity.

(8) Press the outer rotor body to one side with the fingers and measure the clearance between the outer rotor and the pump body (Fig. 7).

(9) If the measurement is more than .012 inch,

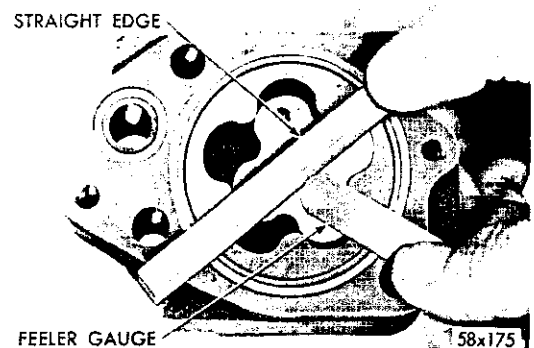

Fig. 6—Measuring the Clearance Over Rotors

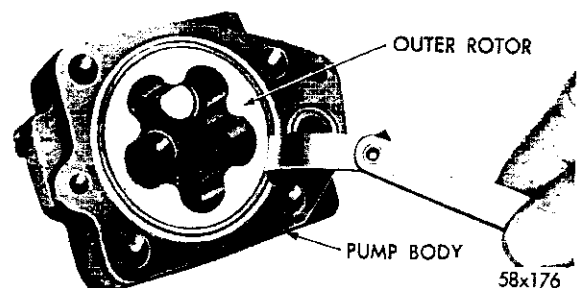

Fig. 7—Measuring the Outer Rotor Clearance

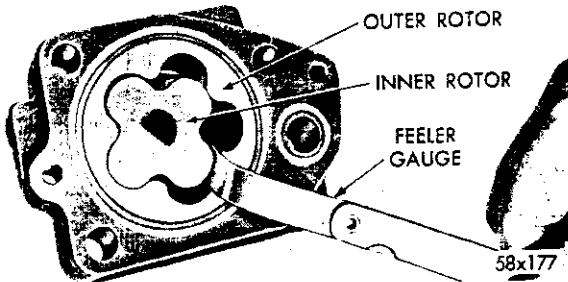

Fig. 8—Measuring the Clearance Between Rotors

replace the oil pump body.

(10) If the top clearance between the inner and outer rotor (Fig. 8) is more than .010 inch, replace the inner and outer rotors.

d. Servicing Oil Pressure Relief Valve

Inspect the relief valve plunger, spring and damper. If the plunger is scratched, remove the scratches by polishing, or install a new filter base assembly which includes the plunger. If the old plunger is to be reinstalled, clean it and flush out the bore with engine oil.

If the spring is to be replaced, use a new one of the same type. Do not use a heavier spring to raise the oil pressure. If the oil pressure is low, inspect for worn bearings or look for other causes of possible loss of oil pressure. Different colored springs are used in the oil pressure relief valve. The same colored spring should be installed. The springs come in three colors: Gray (light), Red (standard), Brown (heavy). Be sure the damper is in place when the spring is installed.

NOTE: When assembling the oil pump, be sure to use new oil seal rings between the filter base and pump body.

e. Installation

(1) Install a new "O" ring seal on the pilot of the

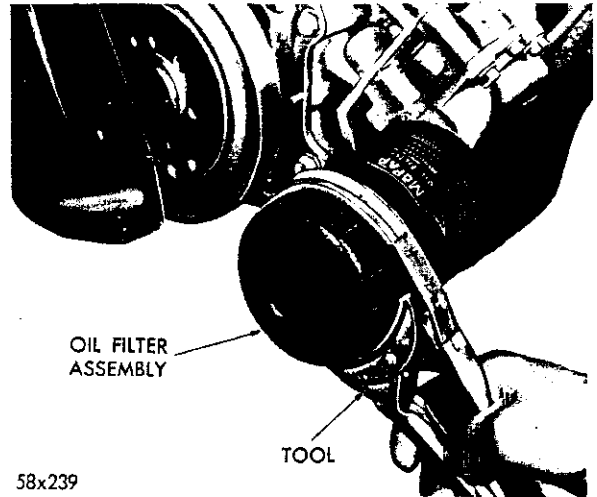

Fig. 9—Removing or Installing the Oil Filter

oil pump before attaching the oil pump to the cylinder block.

(2) Install the oil pump on the engine, using a new gasket on the engine and tighten the attaching bolts to 35 foot-pounds torque.

(3) Install the oil filter element.

OIL FILTER REPLACEMENT

The "spin on" oil filter should be replaced at every 4,000 miles to coincide with an oil change.

a. Removal (Fig. 9)

Note: Use care so as not to damage the transmission oil cooler lines.

(1) Using Tool C-3654 unscrew the filter from the base on the bottom side of the engine and discard.

(2) Wipe the base clean.

b. Installation

(1) Install the "spin on" oil filter by hand, finger tight. Do not use the tool.

(2) Tighten $\frac{1}{2}$ turn only by hand. Check the engine oil level and add oil. Start the engine and check for leaks.