

**GROUP 24**  
**AIR CONDITIONING**  
**CONTENTS**

	<b>Page</b>
AntiFreeze Recommendations .....	28
Complete System Discharge and Recharge .....	41
Compressor Drive Belt Adjustment .....	28
Compressor Removal and Installation .....	33
Data and Specifications .....	1
Electrical Controls and Circuits .....	4
Expansion Valve, Heater Core, Evaporator, Blower Removal and Installation .....	37
Inspection, Test Procedure and Diagnosis .....	5
Magnetic Clutch .....	30
Operation (Air Conditioning) .....	3
Radiator Pressure Cap .....	28
Safety Precautions .....	27
Test 1—Test System Pressure .....	8
Test 2—Refrigerant Level and Moisture .....	8
Test 3—Test the System for Leaks .....	9
Test 4—Correcting Low Refrigerant Level .....	11
Test 5—Performance Test .....	11
Test 6—The Evaporator Pressure Regulator Valve Test .....	21
Test 7—The Compressor Capacity Test .....	22
Test 8—The Expansion Valve Test .....	24
Vacuum Control System Adjustments and Tests .....	28
Service Diagnosis .....	45

---

**DATA AND SPECIFICATIONS**

**COMPRESSOR**

Location .....	Left of Center on Cylinder Block
Type .....	2 Cylinder "V" Type
Bore .....	2 $\frac{5}{16}$ inch
Stroke .....	1 $\frac{1}{8}$ inch
Displacement .....	9.45 cubic inches
Type Valve .....	Reed Type
Speed (depends on axle ratio and tire size) .....	Approximately 1250 rpm at 25 mph
Oil Capacity (Refrigerant Oil) .....	11 ounces
Clutch .....	Stationary Coil
Muffler .....	In Compressor Discharge Line

---



**TIGHTENING REFERENCE**

	Foot-Pounds	Inch-Pounds
Compressor Bearing Housing Bolt .....	10-13	
Compressor to Bracket Bolt .....	50	
Compressor Connecting Rod Screw .....		52-56
Compressor Cylinder Head Cover Bolt .....	23-27	
Compressor Cylinder Head Cover (Nameplate) Bolt .....	20-24	
Compressor Discharge Adapter Bolt .....	14-18	
Compressor to Engine Bolt .....	30	
Compressor Oil Pump Cover Bolt .....	10-13	
Compressor Oil Sump .....	15-19	
Compressor to Strut Bolt .....	30	
Compressor Suction Adapter Bolt .....	10-14	
Magnetic Clutch to Compressor Bolt .....	20	

**FLARE NUT TORQUES**

Flare Size	Foot-Pounds	Flare Size	Foot-Pounds
$\frac{1}{4}$ SAE .....	12-14	$\frac{1}{2}$ SAE .....	30-35
$\frac{3}{8}$ SAE .....	20-25	$\frac{5}{8}$ SAE .....	55-65

**GROUP 24****AIR-CONDITIONING**

Three types of original equipment air conditioning installations are available for the 1962 models. The first option is a combination air conditioning and heating unit. It is a dash-mounted unit, operated by push buttons conveniently located on the instrument panel. A dual installation consisting of the combination front unit and a rear-unit evaporator assembly mounted in the luggage compartment is also available. This deluxe installation insures equal distribution of conditioned air to rear seat as well as front-seat passengers. The third option is a deluxe installation for the Town and Country Models only. It consists of the combination dash-mounted unit and a special roof-mounted evaporator assembly installed at the rear of the Town and Country Models.

The dash-mounted front unit is the basic factory installed option. The rear unit, mounted in the luggage compartment, and the roof unit for the Town and Country Models, are not available as single units without the front unit. Since both of these rear unit options operate automatically in conjunction with the front unit, only the front unit will be described in detail.

**OPERATION**

Selection of the degree of air conditioning desired is by means of push buttons conveniently located on the instrument panel. A sliding lever, in the same panel with the push buttons, provides control of the hot water flow through the heater core to regulate

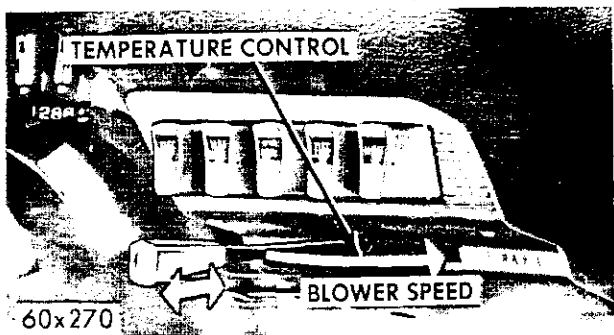

Fig. 1—Air Conditioning Controls

the temperature (Refer to Fig. 1). The switch for the electric blower motor control is mounted on the end of the sliding lever. The blower motor has three speeds—low speed with the switch knob pushed in, high speed with the switch knob pulled out and medium speed between these two extremes.

Operation of the doors and damper which direct air flow through the combination heater and air-conditioning unit is by means of vacuum diaphragm units called vacuum actuators. The vacuum source is the engine intake manifold. Vacuum lines connect to each side of the vacuum actuator diaphragm, with the push button serving as a "switch valve" to admit vacuum to one side or the other of the vacuum actuator diaphragm. The diaphragm is connected to

the door or damper by a rod and suitable linkage. Movement of the diaphragm, therefore, opens or closes the door or damper.

The push buttons also control the electrical circuits to the magnetic clutch and to the blower switch. The switch on the end of the temperature control lever controls the blower speed.

### ELECTRICAL CONTROLS AND CIRCUITS

On all air-conditioning systems (front-unit type) there are two switches, one for the clutch control circuit and one for the blower motor speed control circuit. The push-button switch assembly controls the clutch circuit. The push-button switch also controls the "feed" circuit to the blower motor speed control switch mounted on the temperature control lever.

#### a. Push-Button Control

The power "feed" circuit connects directly to the air conditioning terminal of the fuse block. (Fig. 2)

The clutch circuit is energized ("hot") only when the "Maximum Cool", or the "Fresh Cool" push buttons are depressed. The low-speed blower motor circuit and the power "feed" circuit to the blower motor speed control switch are energized ("hot") when any button other than the "off" button, is depressed.

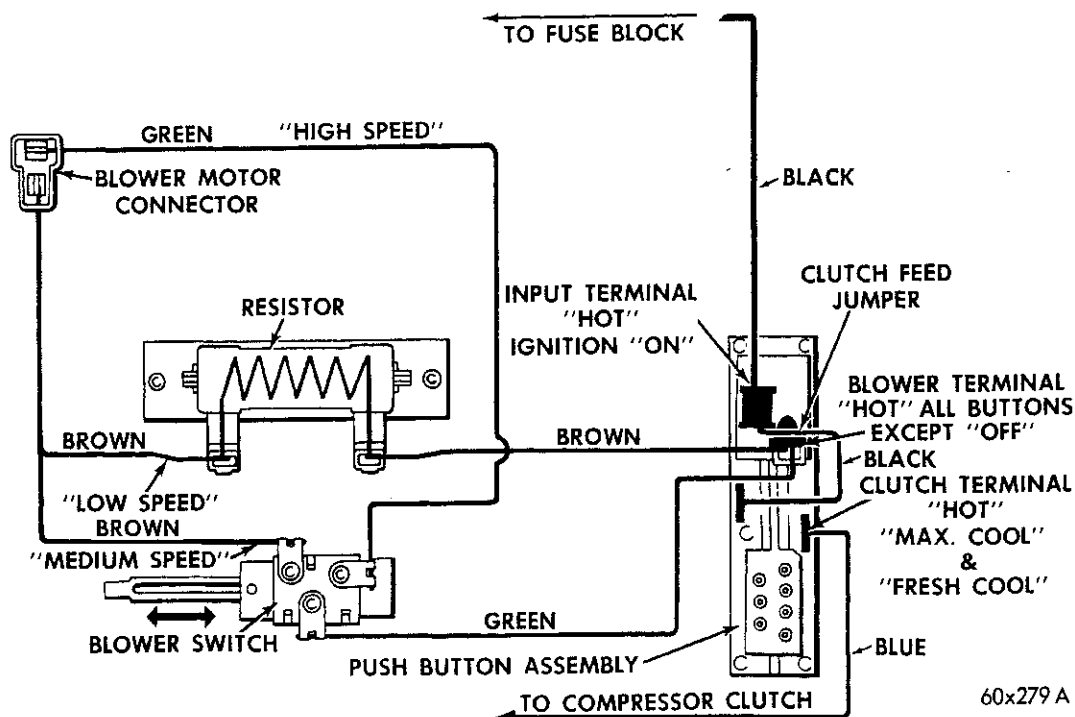

Fig. 2—Electrical Control Circuits

60x279 A

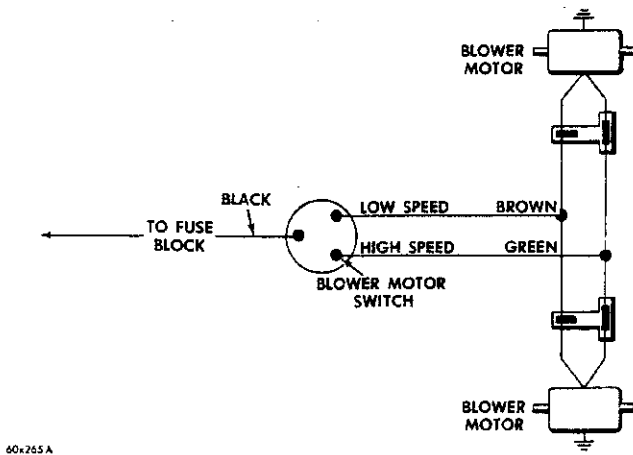

Fig. 3—Trunk Unit Wiring Diagram—  
Chrysler and Imperial

#### b. Blower Motor Speed Control Switch

The speed control switch and control circuits are the same for all models, and the switch is controlled by moving the temperature control lever in or out.

#### c. Trunk Unit and Roof Unit Controls

The trunk unit and the roof unit evaporators are dependent upon the controls used to operate the front unit. The evaporator of a trunk unit or a roof unit of a dual installation will "cool" only when the "MAXIMUM COOL" or the "FRESH COOL" push button of the front unit control is depressed to energize the magnetic compressor clutch.

The blower circuits of the trunk unit and the roof unit are entirely independent of the front unit. (Figs.

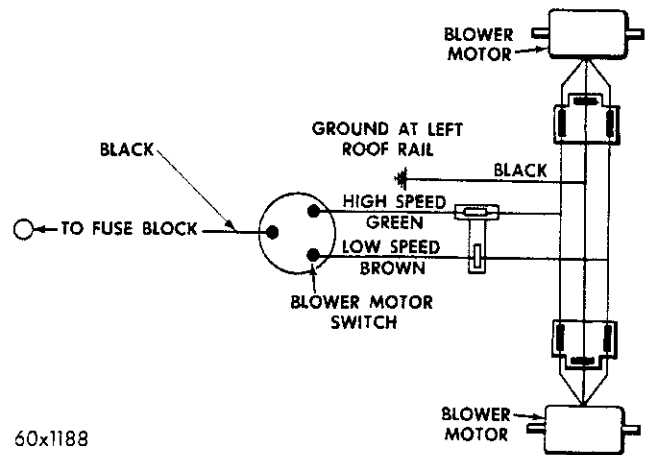

Fig. 4—Roof Unit Wiring Diagram Chrysler  
(Town and Country)

3 and 4)

#### d. Antifreeze Required for Summer Operation

The Air-Conditioning system requires the engine's cooling system to be protected to  $+15^{\circ}\text{F}$ . with a permanent-type anti-freeze for summer operation. This is to prevent freezing of the coolant in the heater core.

#### e. Bug Screens

Bug screens should not be installed on cars equipped with air conditioning. A bug screen installed in front of the condenser will reduce air flow and affect air-conditioning performance. Under severe heat conditions a bug screen may cause the engine to overheat.

## INSPECTION, TEST PROCEDURE AND DIAGNOSIS

### THE GAUGE SET MANIFOLD

The gauge set manifold (Tool C-3740) has two compound suction gauges and one discharge pressure gauge. Two accurately calibrated suction pressure gauges are required for the evaporator pressure regulator valve test. A modification kit (Tool C-3741) contains all of the parts necessary to convert the previous gauge set manifold (Tool C-3627) for testing the 1962 Air-Conditioning System. (Refer to Fig. 5)

### PRELIMINARY TEST, INSPECTIONS AND ADJUSTMENTS

Satisfactory performance of the combined air-conditioning and heating system is dependent upon proper operation and adjustment of all operating controls, as well as proper functioning of all refrigeration system units.

#### a. Test the Operation of All Controls

Operating controls must be tested as described in

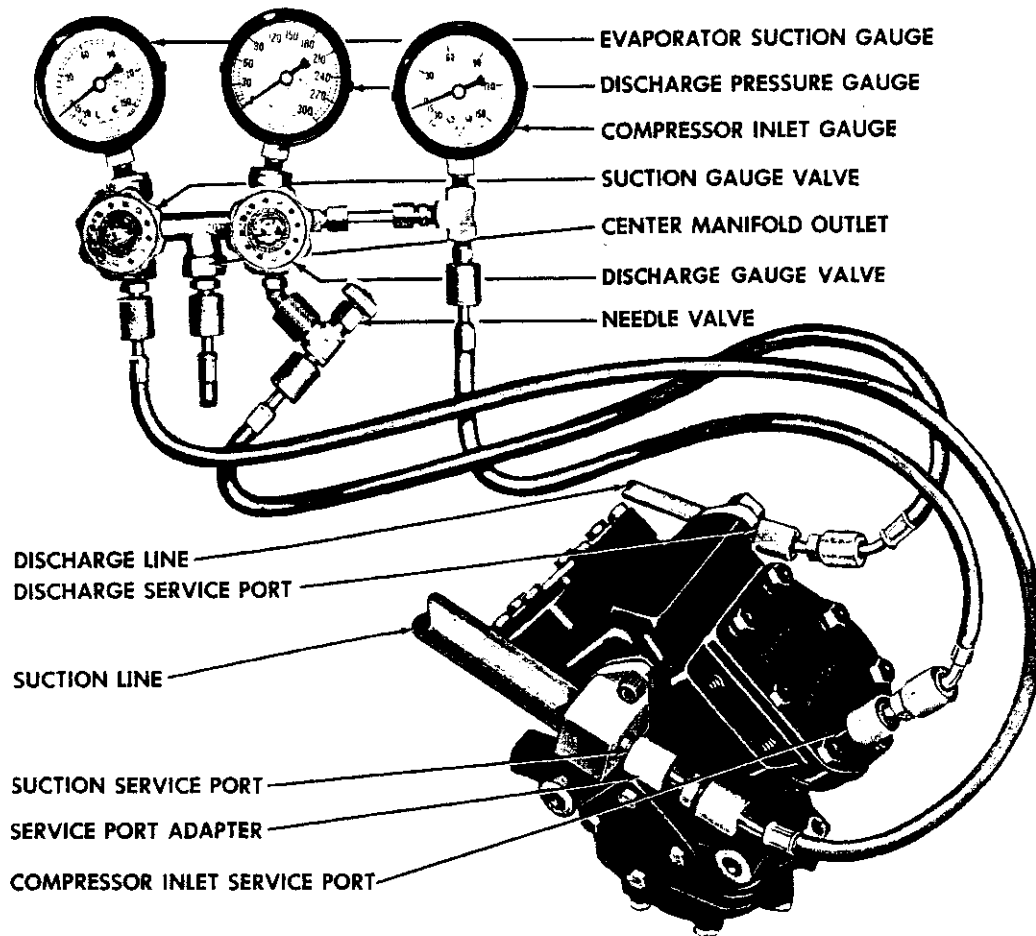

Fig. 5—Gauge Set Manifold Connections

60x268 A

the following sequence:

- (1) Inspect compressor drive belt tension—Adjust if necessary.
- (2) Open the car windows.
- (3) Move the temperature control lever to the "OFF" position.
- (4) Start the engine and adjust engine speed to 1250 RPM. Use a reliable tachometer.
- (5) Push the "FRESH COOL" button in.
- (6) Test blower operation at all three speed positions. If blower does not operate correctly, refer to Paragraph "Electrical Controls and Circuits". Leave the blower in the "High" position.
- (7) The compressor clutch should be engaged, the compressor operating, and the air-conditioning system in operation. If the clutch does not engage, test the circuit. (Refer to "Electrical Controls and Circuits".

#### b. Test the Push Button Operation

Reduce the engine speed to normal idle. With the engine operating at idle speed, the vacuum will be high and the vacuum actuators should operate quickly. If the actuator operation is slow, check the source hose connection at the engine manifold. Push each button to test the over-all operation of the electrical and vacuum controls. The Push Button Control Chart summarizes the actions that should take place when each button is pushed.

If all controls operate in the proper sequence but action of dampers and doors is slow or incomplete, inspect for mechanical misalignment, binding or improper linkage adjustment.

#### c. Water Temperature Control Valve Adjustment

Move the temperature control lever on the instrument panel to the extreme "WARM" position, and then back to the "OFF" position. At the same time,

## PUSH BUTTON CONTROL CHART

BUTTON	OFF	MAX. COOL	FRESH COOL	DEFROST	HEAT
FRESH AIR DOOR	CLOSED	CLOSED	OPEN	OPEN	OPEN
RECIRCULATING DOOR	OPEN	OPEN	CLOSED	CLOSED	CLOSED
BYPASS DOOR	OPEN	OPEN	OPEN	CLOSED	CLOSED
DEFLECTOR	UP	UP	UP	DOWN	DOWN
DAMPER	DOWN	DOWN	DOWN	DOWN	UP
BLOWER SPEED	OFF	HI-MED. LOW	HI-MED. LOW	HI-MED. LOW	HI-MED. LOW
COMPRESSOR CLUTCH	OFF	ON	ON	OFF	OFF

inspect the control cable action and the movement of the water temperature control valve lever. The valve should be moved to the wide-open position and back to the fully closed position. Figure 6 shows the valve in the fully closed position. The water valve is pushed to open and pulled to close.

If the temperature control valve does not close completely, reposition the control cable housing in the retaining clip so that the valve does close completely.

Test the water valve by momentarily disconnecting the heater outlet hose at the upper side of the heater housing. (Fig. 7) A slight spillage of water when the hose is removed is normal. (The radiator cap was removed at the start of this test to minimize pressure in the car's cooling system.) A continuous flow of water indicates that the valve is not

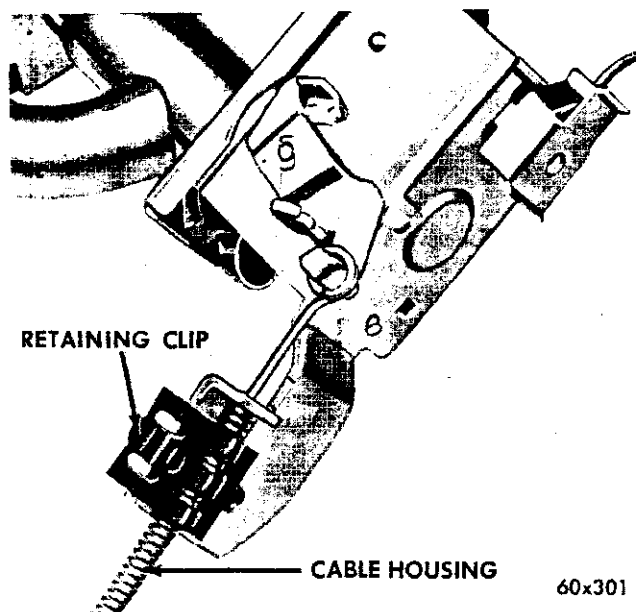

Fig. 6—Temperature Control Valve Closed

closing properly. This may be caused by an improperly adjusted control cable or a faulty valve. Readjust the control cable or replace the valve, as necessary, and retest.

#### d. Radiator Cap

It is an absolute necessity for the air-conditioned vehicle to be equipped with a radiator cap having a holding pressure of 15 to 16 psi, for hot weather operation.

#### e. Inspect the Condenser and Sub-Cooler

Inspect the condenser and sub-cooler fins for obstructions for foreign matter. Clean if necessary.

Any obstructions to the free flow of air across the condenser and/or sub-cooler will decrease heat dissipation from the condenser, decrease the efficiency of the condenser and, in turn, decrease the evaporator's efficiency. These conditions result in in-



Fig. 7—Water Valve Test

creasing the discharge pressure and horsepower load on the engine. The use of a bug screen is not recommended as it, too, will decrease the free flow of air.

Inspect the condenser and sub-cooler for bent or damaged fins.

The bent fins on the condenser and/or sub-cooler deflect air flow across the bent portions, decreasing the condenser area. By careful use of the condenser comb, Tool C-3663 (Fig. 8), the fins can be straightened to their original shape and efficiency. Be sure the fan shroud is properly positioned.

### TEST 1

#### TEST SYSTEM PRESSURE (ENGINE NOT RUNNING)

Install the gauge set manifold. For identification of test hose connections at service port see Figure 5. After tightening all three service port adapters, make sure that the needle valve located below the discharge pressure gauge is open. Purge air from the gauge hoses (Fig. 9) as follows:

- (1) Open the suction gauge valve momentarily, then close it.
- (2) Open the discharge gauge valve momentarily, then close it.
- (3) Loosen the compressor inlet suction hose connection at the manifold momentarily, then tighten it.

If the vehicle has been parked and the system not operating, gauge pressure should be normal for temperature of the system. Refer to the Temperature-Pressure Relationship Chart.

If no pressure is indicated on the gauges it means

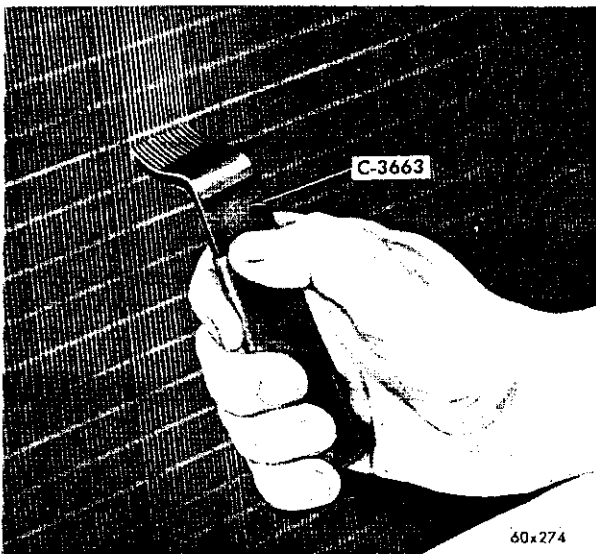

Fig. 8—Condenser Comb

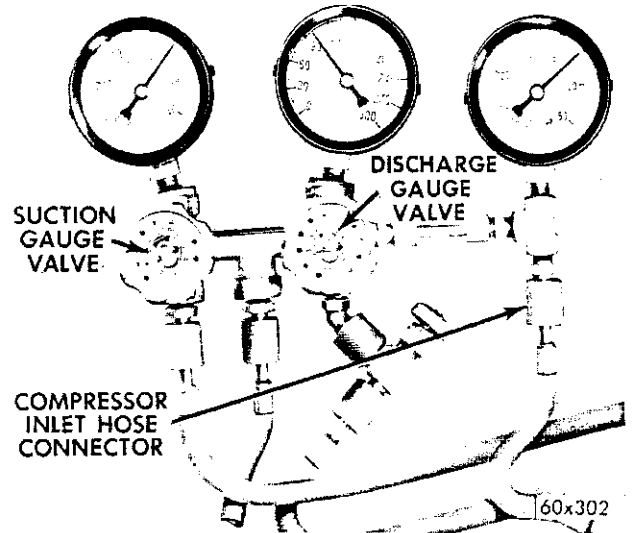

Fig. 9—Purge Gauge Hoses

that the system is empty, due to a leak. It will be necessary to evacuate, charge with a sweep-test charge, locate and correct the leak, purge the test charge, replace the drier, vacuum the system and charge the system with the proper amount of Refrigerant 12.

If pressures are normal, proceed with the next test and adjustment.

### TEST 2

#### REFRIGERANT LEVEL AND MOISTURE

If the system is a dual system, both units must be operated simultaneously at high blower speed when this test is made, and when adding to the charge.

The arrow on the sight glass (Fig. 10) must point

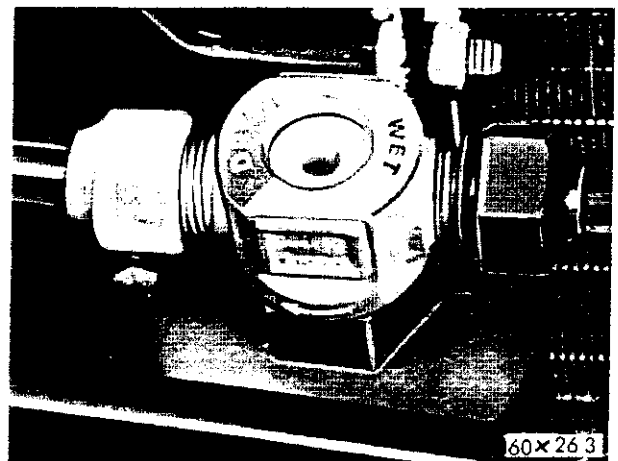

Fig. 10—Sight Glass and Dry Eye



**TEMPERATURE-PRESSURE RELATIONSHIP CHART**  
(FOR REFRIGERANT 12)

Temp. F.	Pressure PSI	Temp. F.	Pressure PSI	Temp. F.	Pressure PSI	Temp. F.	Pressure PSI	Temp. F.	Pressure PSI
0	9.1	35	32.5	60	57.7	85	91.7	110	136.0
2	10.1	36	33.4	61	58.9	86	93.2	111	138.0
4	11.2	37	34.3	62	60.0	87	94.8	112	140.1
6	12.3	38	35.1	63	61.3	88	96.4	113	142.1
8	13.4	39	36.0	64	62.5	89	98.0	114	144.2
10	14.6	40	36.9	65	63.7	90	99.6	115	146.3
12	15.8	41	37.9	66	64.9	91	101.3	116	148.4
14	17.1	42	38.8	67	66.2	92	103.0	117	151.2
16	18.3	43	39.7	68	67.5	93	104.6	118	152.7
18	19.7	44	40.7	69	68.8	94	106.3	119	154.9
20	21.0	45	41.7	70	70.1	95	108.1	120	157.1
21	21.7	46	42.6	71	71.4	96	109.8	121	159.3
22	22.4	47	43.6	72	72.8	97	111.5	122	161.5
23	23.1	48	44.6	73	74.2	98	113.3	123	163.8
24	23.8	49	45.6	74	75.5	99	115.1	124	166.1
25	24.6	50	46.6	75	76.9	100	116.9	125	168.4
26	25.3	51	47.8	76	78.3	101	118.8	126	170.7
27	26.1	52	48.7	77	79.2	102	120.6	127	173.1
28	26.8	53	49.8	78	81.1	103	122.4	128	175.4
29	27.6	54	50.9	79	82.5	104	124.3	129	177.8
30	28.4	55	52.0	80	84.0	105	126.2	130	182.2
31	29.2	56	53.1	81	85.5	106	128.1	131	182.6
32	30.0	57	55.4	82	87.0	107	130.0	132	185.1
33	30.9	58	56.6	83	88.5	108	132.1	133	187.6
34	31.7	59	57.1	84	90.1	109	135.1	134	190.1

in the direction of refrigerant flow—toward the line leading to the evaporator. If the arrow is reversed, the system must be purged, sight glass reversed and the system recharged, following the complete procedure for correcting a “wet” system.

Block the air flow across the condenser as required to raise the discharge pressure 225 to 250 psi, and check the sight glass for foam. There should be no foam. If sight glass is clear, remove the air restriction from the condenser and allow the discharge pressure to return to normal.

If foam shows in the sight glass when the discharge pressure is 225 to 250 psi, it indicates the system is low on refrigerant. The proper amount of refrigerant required to complete a full charge may be added to the system as follows: Maintaining the discharge pressure at 225 to 250 psi, add refrigerant

gas through the suction side of the system until foam is cleared from sight glass, then add exactly one-half ( $\frac{1}{2}$ ) pound.

Inspect “dry-eye” element for color. It should be blue. If the dry-eye is “pink” or “orchid” color, it indicates the system is wet. Then it will be necessary to purge the refrigerant from the system, replace the receiver-drier and recharge.

### TEST 3

#### TESTING THE SYSTEM FOR LEAKS

The Leak Detector Torch (Tool C-3569) is a propane gas-burning torch used to locate a leak in any part of the refrigeration system. Refrigerant gas drawn into the sampling or “Snifter” tube will cause the flame to change color in proportion to the size of the

leak. A very small leak will produce a flame color varying from yellowish-green to bright green. A large leak will produce a brilliant blue flame.

(1) Open the torch valve until you hear a faint hiss of escaping gas. Light the test torch and adjust the valve until the flame is very small. A small flame will detect large as well as small leaks, whereas a large flame will detect only large leaks. As soon as the reaction plate seen through the window in the burner shield becomes red hot, the tester is ready for use.

(2) Examine all the tube connectors and other possible leak points by moving the end of the sampling hose from point to point. Since Refrigerant 12 is heavier than air, it is good practice to place the open end of the sampling hose directly below the point being tested. Be careful not to pinch the sampling tube since this will shut off the air supply to the flame and cause a color change

(3) Watch for a change in the color of the flame. Small leaks will produce a green and large leaks a bright blue color. If leaks are observed at the tube fittings, tighten the connection, using the proper flare wrenches, and retest

#### α. Test Precautions

Do not use the lighted detector in any place where explosive gases, dust, or vapors are present.

Do not breathe the fumes that are produced by the burning of refrigerant gas. Large concentrations of refrigerant in the presence of a live flame become dangerously toxic. Observe the flame through the window of the burner shield, not through the top of the shield.

If the flame remains bright yellow when the tester is removed from a possible leak point, insufficient air is being drawn in through the sampling tube, or the reaction plate is dirty.

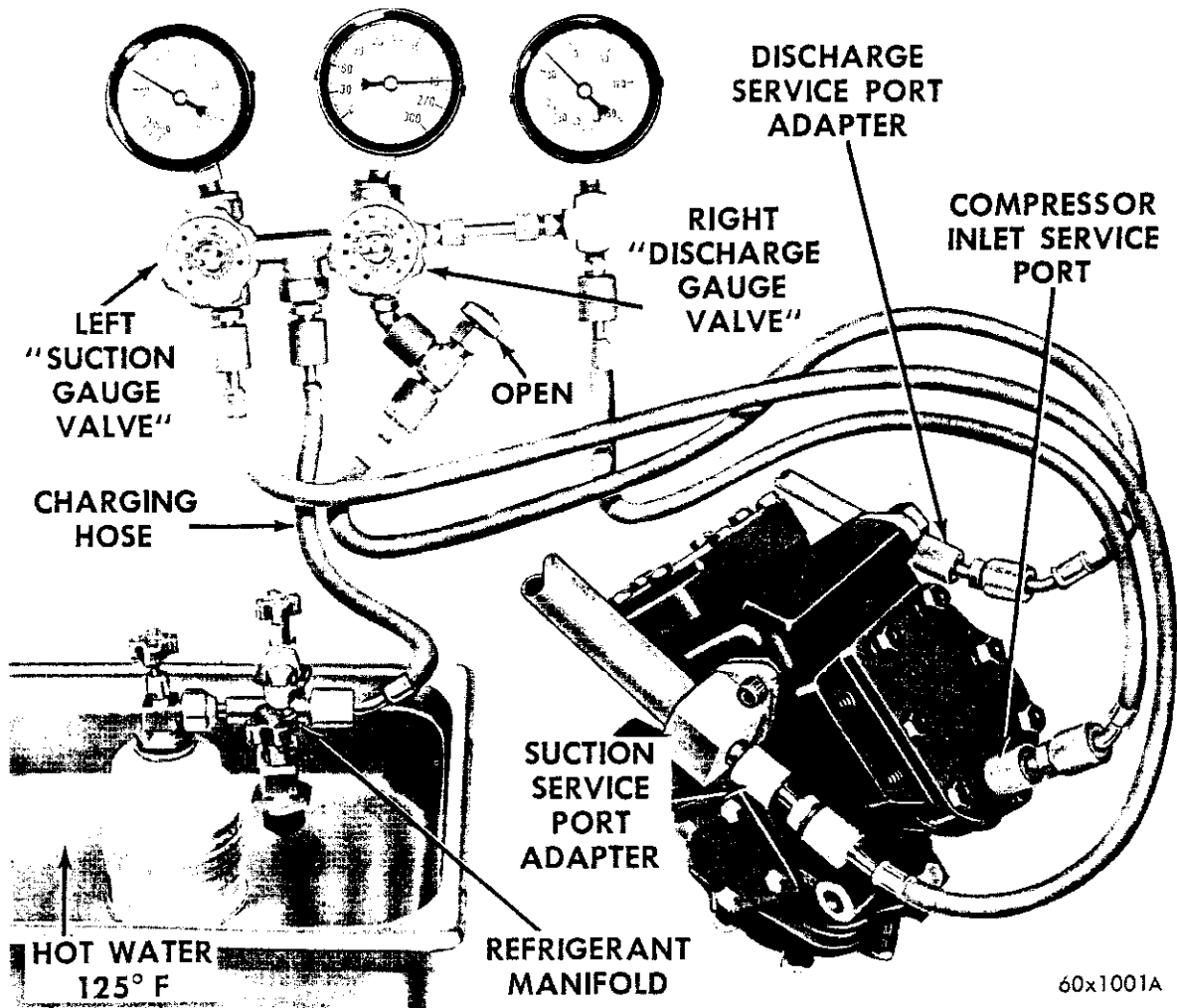

Fig. 11—Adding Partial Refrigerant Charge

60x1001A

### b. Remove Sweep-Test Charge

If the system is free of leaks, or after correcting a leak, or if no air conditioning components have been removed, add the necessary refrigerant as described under "Correcting Low Refrigerant Level." If any parts of the refrigerant system were disconnected, remove the sweep test charge. Close the refrigerant manifold valve so that any refrigerant remaining in the container is sealed. Remove the long test hose from the refrigerant manifold. Insert the free end of this test hose into an exhaust system outlet. Open the right-hand gauge set manifold valve a fraction of a turn to let the sweep-test charge escape slowly. Allow the system to discharge until the discharge pressure gauge registers zero. Open the left-hand gauge valve to allow any refrigerant trapped in the suction side of the system to escape.

### TEST 4

#### CORRECTING LOW REFRIGERANT LEVEL

Since the refrigeration system is completely sealed, the refrigerant level will not be low unless there is a leak in the system or the refrigerant has been allowed to escape by depressing one of the service port valves. For detailed instructions on the proper procedure for checking refrigerant level, refer to TEST 2 "Refrigerant Level and Moisture."

Before adding the refrigerant where the cause of low level is not known, the system should be tested for leaks. Assuming no leaks are present, or that leaks have been corrected without discharging the system, proceed with partial charge (refer to Fig. 11).

Install and connect the gauge set manifold as shown in figure 11.

(1) Place the refrigerant in a large pan of water heated to 125° F. Place the pan of water containing the refrigerant can on an accurate scale Tool C-3429 so that the amount of refrigerant added can be weighed. Open the refrigerant manifold valve.

(2) Slowly open the suction service gauge valve. Meter the flow of refrigerant by adjusting the suction service gauge valve so that the pressure registered at the suction service gauge does not exceed 50 psi. **Keep the refrigerant container upright.**

(3) Add refrigerant gas until there is no foam visible at the sight glass. As soon as all foam clears, note the weight registered on the refrigerant scale.

(4) Watch the refrigerant weighing scale and add **EXACTLY** ½ pound more refrigerant to the system. Close the suction gauge valve.

**NOTE:** Too much refrigerant in the system can cause abnormally high discharge pressures. Care must be used so that exactly ½ pound of refrigerant is added after foam clears in the sight glass.

(5) Close the dispensing manifold valve. Remove the test hoses and adapters from the service ports of the compressor, and install the protective caps at the service ports.

### TEST 5

#### PERFORMANCE TEST

Humidity (the amount of moisture in the air) has an important bearing on the temperature of the air delivered to the vehicle interior. High humidity greatly reduces the evaporator's ability to lower the temperature of the air delivered to the vehicle's interior.

Evaporator capacity used to reduce the amount of moisture in the air is not wasted. Wringing some of the moisture out of the air entering the vehicle adds materially to the comfort of the passengers. An owner may expect too much, however, from his air-conditioning system on humid days. A performance test is the best way to determine whether or not the system is performing up to standard. This test also provides valuable clues to the possible cause of trouble.

#### a. Performance Test Preparations

The Gauge Set Manifold should be connected as shown in Fig. 11 according to instructions covered in "Gauge Set Manifold Connections" Test 2. Move the temperature control lever to "OFF" position.

Start the engine, push in "FRESH COOL" button pull blower switch to high position.

**NOTE:** When testing front unit of a dual system, leave the rear or roof unit blower turned off.

Adjust engine speed to 1250 rpm. Arrange the gauge set manifold hoses and tachometer leads to allow the hood to be lowered, and close the hood.

Install the motor-driven psychrometer (Tool C-3704) near the air inlet grille, as shown in Fig. 12. Install the thermometer (Tool C-3623) in the right-hand instrument panel outlet grille.

Operate the air-conditioning system until a stabilized condition on the gauges and thermometers has been established. One of the most important factors in making the over-all performance test is that the engine must be operated at 1250 rpm for a sufficient time to build up to operating temperatures and allow all the under-hood components of the system to

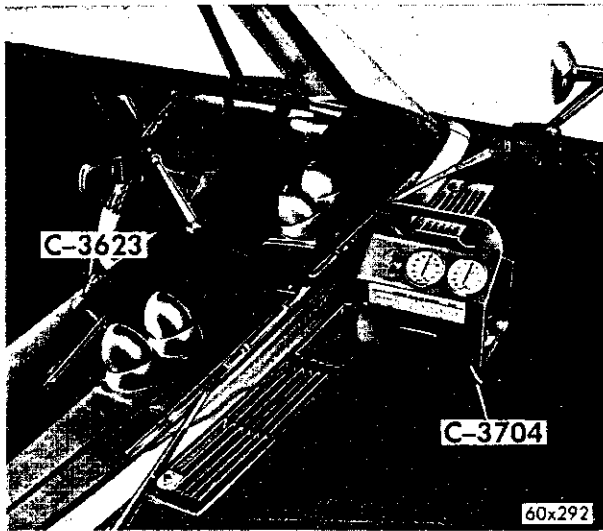

Fig. 12—Psychrometer and Thermometer

be subjected to the under-hood operating temperature for a period of time.

Partially close the needle valve, located below the discharge pressure gauge, to minimize oscillation of the discharge gauge pointer. Do not close the needle valve completely since this would prevent the discharge pressure gauge from registering discharge pressures.

Read the discharge pressure on the gauge. This test should be performed with the discharge pressure from 190 to 210 psi. The 190 to 210 pound pressure is for test purposes only. These pressures change according to the ambient temperatures, humidity and the efficiency of the entire system.

Take the necessary steps to bring and maintain the discharge pressure within these limits.

To increase the discharge pressure, restrict the air flow across the condenser using cardboard, paper,

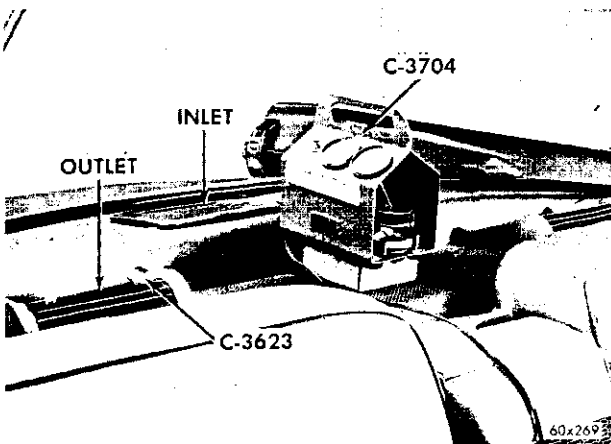

Fig. 13—Trunk Unit Performance Test

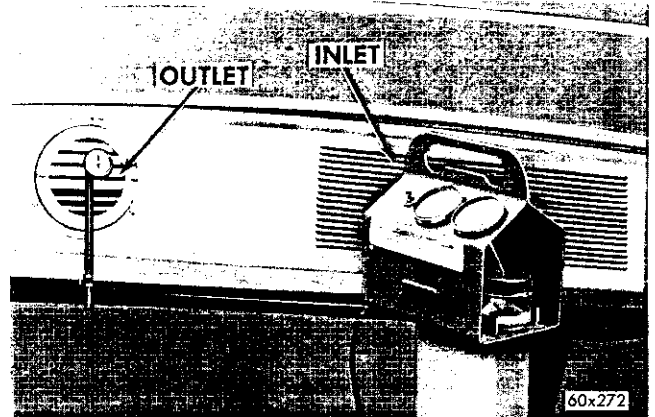

Fig. 14—Roof Unit Performance Test

etc. In high ambient temperatures and high humidity areas, it may be necessary to put an electric fan in front of the condenser in order to keep the pressure down to these limits.

#### b. Determination of System Performance

Observe and record both the "Inlet Dry Bulb Temperature" and "Inlet Wet Bulb Temperature" as registered on the psychrometer.

Observe and record the "Discharge Air Temperature" registered by the thermometer at the right-hand grille outlet.

From the appropriate Front Unit Performance Temperature Chart for vehicle and type of installation being tested, Figs. 15 through 22, determine the maximum allowable discharge air temperature for the prevailing "Dry" and "Wet" bulb temperatures recorded. If the vehicles discharge air temperature is at or below the temperature given on the Performance Chart, the air conditioning is delivering its rated cooling capacity.

#### c. Trunk Unit Performance Test

The method used to test the trunk unit of a dual installation is essentially the same as for a front unit. The front unit should be tested before testing the trunk unit. When testing the trunk unit of a dual system, turn the front unit off by pushing the "OFF" button. Next, connect a jumper from the positive terminal of the battery to the compressor so that the refrigeration part of the entire system can be operated without air-flow through the front unit.

#### d. Roof Unit Performance Test

The method used to test the roof unit of a dual installation is essentially the same as for a front unit. The front unit should be tested before testing the





### 1962 AIR CONDITIONING PERFORMANCE CHART

DRY BULB TEMP.	WET BULB AIR TEMPERATURE																																										
	52	53	54	55	56	57	58	59	60	61	62	63	64	65	66	67	68	69	70	71	72	73	74	75	76	77	78	79	80	81	82	83	84	85	86	87	88	89	90				
75	46	46	46	46	46	46	46	46	47	47	47	47	48	48	49	49	50	51	51	52	53	53	54	55																			
76	46	46	46	46	46	46	47	47	47	47	47	48	48	49	49	50	51	51	52	53	54	54	55	55																			
77	46	46	46	46	47	47	47	47	47	47	48	48	48	49	49	50	51	51	52	53	54	55	55	55	57																		
78	46	46	47	47	47	47	47	47	48	48	48	48	48	49	49	50	50	51	52	52	53	54	55	55	56	57	58																
79	47	47	47	47	47	47	47	48	48	48	48	48	48	49	49	50	50	51	52	52	53	54	55	56	56	57	58	59															
80	47	47	47	47	47	48	48	48	48	48	48	48	48	49	49	50	50	51	52	52	53	54	55	56	57	57	58	59	60														
81	47	47	47	48	48	48	48	48	48	48	49	49	49	49	50	50	51	51	52	53	53	54	55	56	57	58	59	60	61	61													
82	48	48	48	48	48	48	48	48	49	49	49	49	50	50	51	51	52	52	53	54	54	55	56	57	58	59	60	61	62	62													
83	48	48	48	49	49	49	49	49	49	49	50	50	50	51	51	52	52	53	53	54	55	56	56	57	58	59	60	61	62	63	64												
84	49	49	49	49	49	49	50	50	50	50	50	50	51	51	51	52	52	53	54	54	55	56	57	57	58	59	60	61	62	63	64	65											
85	49	49	49	49	50	50	50	50	50	50	50	51	51	51	52	52	53	53	54	55	55	56	57	58	58	59	60	61	62	63	64	65	66										
86	50	50	50	50	50	50	50	51	51	51	51	51	51	52	52	53	53	54	55	55	56	57	58	59	59	60	61	62	63	64	65	66	66										
87	50	50	50	50	51	51	51	51	51	51	52	52	52	52	52	53	53	54	54	55	56	56	57	58	59	60	61	61	62	63	64	65	66	66	67								
88	51	51	51	51	51	51	52	52	52	52	52	52	52	52	53	53	53	54	55	55	56	57	57	58	59	60	61	62	62	63	64	65	66	66	67	68							
89	52	52	52	52	52	52	52	52	52	52	52	53	53	53	53	53	54	54	55	55	56	57	58	58	59	60	61	62	62	63	64	65	66	66	67	68	69						
90				52	52	52	52	53	53	53	53	53	53	53	53	54	54	54	55	56	56	57	58	59	59	60	61	62	63	63	64	65	66	67	67	68	69	70					
91				53	53	53	53	53	53	53	53	53	53	53	54	54	54	55	55	56	56	57	58	59	59	60	61	62	63	64	64	65	66	67	68	68	69	70	71				
92				53	53	53	53	54	54	54	54	54	54	54	54	54	55	55	56	56	57	57	58	59	59	60	61	62	63	64	64	65	66	67	68	68	69	70	71				
93				54	54	54	54	54	54	54	54	54	54	54	55	55	55	56	56	57	57	58	59	59	60	61	61	62	63	64	64	65	66	67	68	68	69	70	71				
94				55	55	55	55	55	55	55	55	55	55	55	55	55	56	56	56	57	57	58	58	59	59	60	61	61	62	63	64	64	65	66	67	68	68	69	70	71			
95				55	55	55	55	55	55	55	55	55	55	55	55	56	56	56	57	57	58	58	59	60	60	61	61	62	63	64	64	65	66	67	68	68	69	70	71				
96				56	56	56	56	56	56	56	56	56	56	56	56	56	56	57	57	57	58	59	59	60	60	61	62	62	63	64	65	65	66	67	68	69	69	70	71				
97				56	56	56	56	56	56	56	56	56	56	57	57	57	57	58	58	58	59	59	60	60	61	61	62	63	63	64	65	66	66	67	68	69	70	70	71				
98				57	57	57	57	57	57	57	57	57	57	57	57	57	58	58	59	59	59	59	60	60	61	61	62	62	63	64	65	65	66	67	67	68	69	70	70	71			
99				58	58	58	58	58	58	58	58	58	58	58	58	58	58	59	59	59	59	60	60	61	61	61	62	63	63	64	65	65	66	67	68	68	69	70	70	71			
100				58	58	58	58	58	58	58	58	58	58	58	58	59	59	59	59	59	60	60	60	61	61	61	62	63	63	64	65	65	66	67	68	68	69	70	70	71			
101															59	59	59	59	60	60	60	61	61	61	62	62	63	64	64	65	66	66	67	68	69	69	70	71	72				
102															59	59	60	60	60	60	60	61	61	62	62	63	63	64	64	65	66	67	67	68	69	69	70	71	72				
103															60	60	60	60	60	61	61	61	62	62	62	63	63	64	64	65	66	67	68	68	69	70	71	72	72				
104															60	60	60	60	61	61	61	61	62	62	63	63	64	64	65	65	66	67	68	68	69	70	71	72	73				
105															60	60	60	61	61	61	62	62	62	63	63	64	64	65	66	66	67	68	68	69	70	71	72	73					
106															61	61	61	61	61	62	62	62	63	63	63	64	64	65	66	66	67	68	69	69	70	71	72	73					
107															61	62	62	62	62	62	62	62	63	63	63	64	64	65	65	66	67	67	68	69	70	70	71	72	73				
108															62	62	62	62	62	62	62	63	63	63	63	64	64	65	65	66	66	67	67	68	69	70	71	72	73	74			
109															62	62	62	63	63	63	63	63	63	63	64	64	64	65	65	66	66	67	68	68	69	70	71	72	73	74			
110				60x284 B											63	63	63	63	63	63	63	63	63	63	64	64	64	65	65	66	66	67	68	68	69	70	71	72	73	74			

**MAXIMUM DISCHARGE  
AIR TEMPERATURE**

Fig. 17—Performance Temperature Chart—Trunk Unit of Dual System (Newport and 300)













roof unit. When testing the roof unit of a dual system, turn the front unit off by pushing the "OFF" button. Connect a jumper from the positive terminal of the battery to the compressor so that the refrigeration part of the entire system can be operated without air-flow through the front unit.

If the discharge air temperature at the outlet grilles is above the maximum allowable on the Performance Chart, perform the following operations in the order indicated until proper performance is obtained.

1. "The Evaporator Pressure Regulator Test."
2. "The Compressor Capacity Test."
3. "The Expansion Valve Test."

#### TEST 6

#### THE EVAPORATOR PRESSURE REGULATOR VALVE TEST

The EPR Valve is calibrated to produce the maximum "cooling" possible without causing frost or ice on the evaporator fins and tubing. If for any reason the factory calibration has been disturbed, the EPR valve may restrict the flow of refrigerant at an evaporator pressure which is either too high for maximum performance or too low to prevent coil freeze up.

The evaporator pressure regulator test determines whether or not the valve is functioning properly.

#### EPR Valve Test Conditions

Normally, this test is performed after completion of the "Performance Test". The gauge set manifold

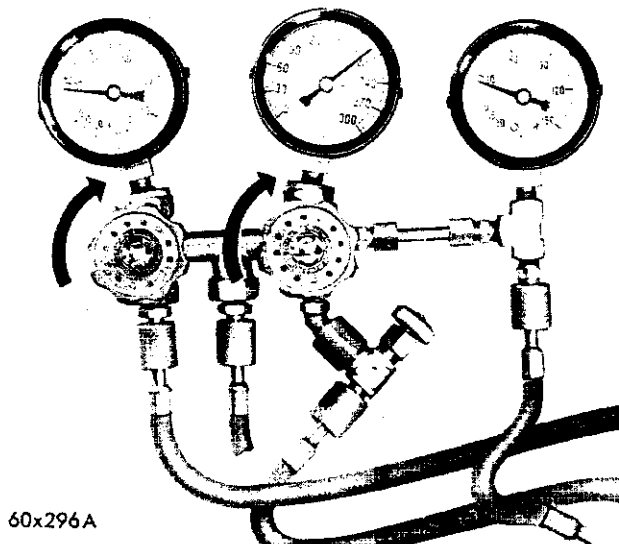

Fig. 23—Pressure, EPR Valve Open

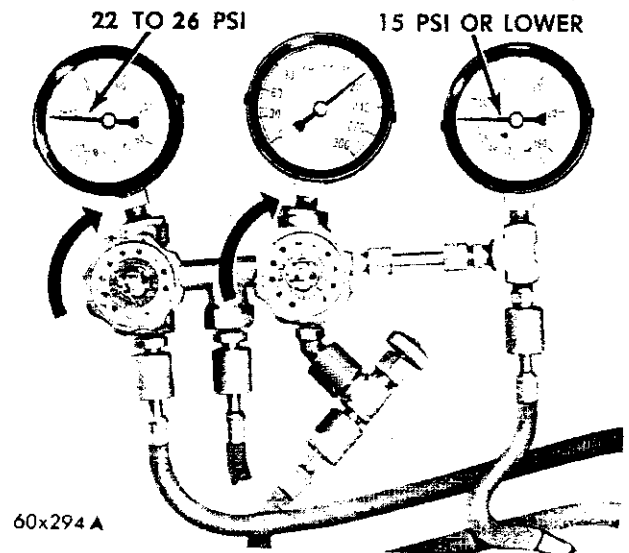

Fig. 24—EPR Valve Test Pressures

will be connected as illustrated in Figure 5.

Adjust the engine speed to 1250 rpm. Close the hood for this test. Close the car windows and turn the blower on "HIGH." Push the "FRESH COOL" button.

The heat load on the evaporator will soon call for continuous operation of the refrigeration system. The "EPR" valve will open and the pressure at both the suction port and the compressor inlet service port will be approximately the same. It is normal for the Compressor Inlet pressure to be slightly lower than the evaporator suction pressure.

Observe the evaporator suction gauge and the compressor inlet gauge. Both should register 26 psi (Fig. 23), or slightly higher. This indicates that the EPR valve is open. The next step is to determine the minimum evaporator suction pressure maintained in the suction line by the EPR valve. EPR valve action can be accelerated by reducing the heat load on the evaporator. This is accomplished by pushing the blower control switch to the "LOW SPEED" position, thus reducing the volume of air passing through the evaporator. Push the "MAXIMUM COOL" button. Immediately, the evaporator will start to get colder.

As soon as the blower switch is changed to low speed, and the "MAXIMUM COOL" button is pushed, it is necessary to watch both suction gauges for the following reactions:

- (1) Pressure registered at the evaporator suction gauge will become progressively lower.
- (2) At the same time, the compressor inlet gauge will start to fluctuate. The fluctuation is caused by the alternate opening and closing of the "EPR"

valve. It indicates that suction pressure is reduced to the point where it just about balances the internal spring pressure on the diaphragm. The EPR valve is actually operating as a modulating valve.

(3) When fluctuation at the compressor inlet gauge stops and the pressure registered drops steadily, the "EPR" valve is maintaining minimum suction line pressure. Allow the pressure registered at the compressor inlet gauge to drop to 15 psi or lower, then read the evaporator suction gauge. (Refer to Fig. 24.)

**NOTE: If, and only if, the compressor inlet pressure will not pull down to 15 psi, increase the engine speed to approximately 2000 rpm.**

(4) The suction gauge pressure should be 22 to 26 psi. This indicates that the suction pressure maintained by the "EPR" valve is correct. However, if engine speed is increased to approximately 2000 rpm in order to pull the inlet pressure down to 15 psi, this also increases the suction pressure 24 to 28 psi. Again, determine the pressure at which the valve is fully open.

(5) Turn the blower on high and push the "FRESH COOL" button to increase the heat load on the evaporator. This will increase suction pressure, causing the "EPR" valve to open fully.

(6) Watch both the evaporator suction and the compressor inlet pressure gauge. The pressure registered at the compressor inlet gauge will increase quite rapidly. Both suction gauges should again stabilize at a pressure of 26 psi or slightly higher within a few minutes.

If the minimum suction pressure registered (Step 4, above) is 22 to 26 psi and the suction pressure registered with the valve fully open (Step 6 above) is 31 psi or slightly higher, the EPR valve is functioning normally. A system which passes both the Over-All Performance Test and the "EPR" Valve Test requires no further tests.

**Suction Pressure Above 26 psi.** If the minimum suction pressure is higher than 26 psi (Step 4, above), the evaporator will not get as cold as it should for maximum performance. It will be necessary to replace the EPR valve, repeat the EPR Valve Test and the Performance Test.

**Suction Pressure Below 22 psi.** If suction pressure goes below 22 psi (Step 4, above), the evaporator is too cold. The correction is to replace "EPR" valve and repeat the "EPR" Valve Test.

If the system failed to pass the Performance Test but passed the "EPR" Valve Test, proceed with the Compressor Capacity Test.

## TEST 7

### THE COMPRESSOR CAPACITOR TEST

The Performance Test and the Evaporator Pressure Regulator Valve Test should be performed before testing compressor capacity. These tests are made with the system fully charged with refrigerant. It is necessary to discharge the system before making the Compressor Capacity Test. It is also necessary to discharge the system in order to perform the Expansion Valve Test. It is recommended that tests be made in the order in which they are presented in this service manual. Experience has proven this to be the surest and quickest way to locate and correct the cause of unsatisfactory performance.

If the Compressor Capacity Test is performed immediately after completing the Evaporator Pressure Regulator Valve Test, the compressor will be up to operating temperature and most of the refrigerant oil will have been returned to the compressor crankcase.

If the system has been standing any length of time, it will be necessary to perform the following operations before starting the Compressor Capacity Test:

1. Attach the gauge set manifold.
2. Start the engine and adjust speed to 1250 rpm.
3. Pull the blower to the "HIGH" position, move the temperature control to "OFF" and push the "FRESH COOL" button.
4. Allow the air-conditioning system to operate at full capacity for at least 15 minutes. This will cause most of the compressor oil in the system to be returned to the compressor crankcase.

**It will also insure that the compressor is up to operating temperature, which is very important when making this test.**

#### a. Discharge the System

When making the "Compressor Capacity Test" the compressor must be disconnected from the rest of the system. That means the system must be discharged.

(1) Lead the manifold discharge hose into an exhaust ventilation system or to the outside of the building so the service area will not be filled with refrigerant vapor.

(2) Fully open the manifold needle valve.

(3) Open the discharge (right-hand) gauge valve a small amount. This will allow the refrigerant vapor to discharge slowly.

**CAUTION**

Do not open the valve fully and allow the system to discharge rapidly, since this would sweep some of the refrigerant oil out with the refrigerant.

(4) Allow the system to discharge until the discharge pressure gauge registers zero.

(5) Open the suction (left-hand) gauge valve to release any vapor trapped at the suction side.

**b. Test Preparation and Connections**

After the system is completely discharged, isolate the compressor and connect the gauge set manifold as follows:

(1) Disconnect the discharge line from the muffler. Cap the muffler outlet with a  $\frac{1}{2}$  inch cap. Seal the discharge line.

(2) Disconnect the evaporator suction line (hose) from the suction fitting. Use a  $\frac{5}{8}$  inch flare fitting cap to close off the suction line fitting. Seal the suction line.

The compressor is now isolated from the system and sealed at both the suction and the discharge sides. Refer to Figure 25, and make the following gauge set manifold connections:

(3) Disconnect the test hose and adapter from the compressor inlet port.

(4) Remove the valve body from the compressor inlet port. The tire valve stem Tool C-3788 can be used for this purpose.

(5) Disconnect the test hose from the suction service port of the fitting.

(6) Install the test cap (SP-2922) at the center manifold outlet.

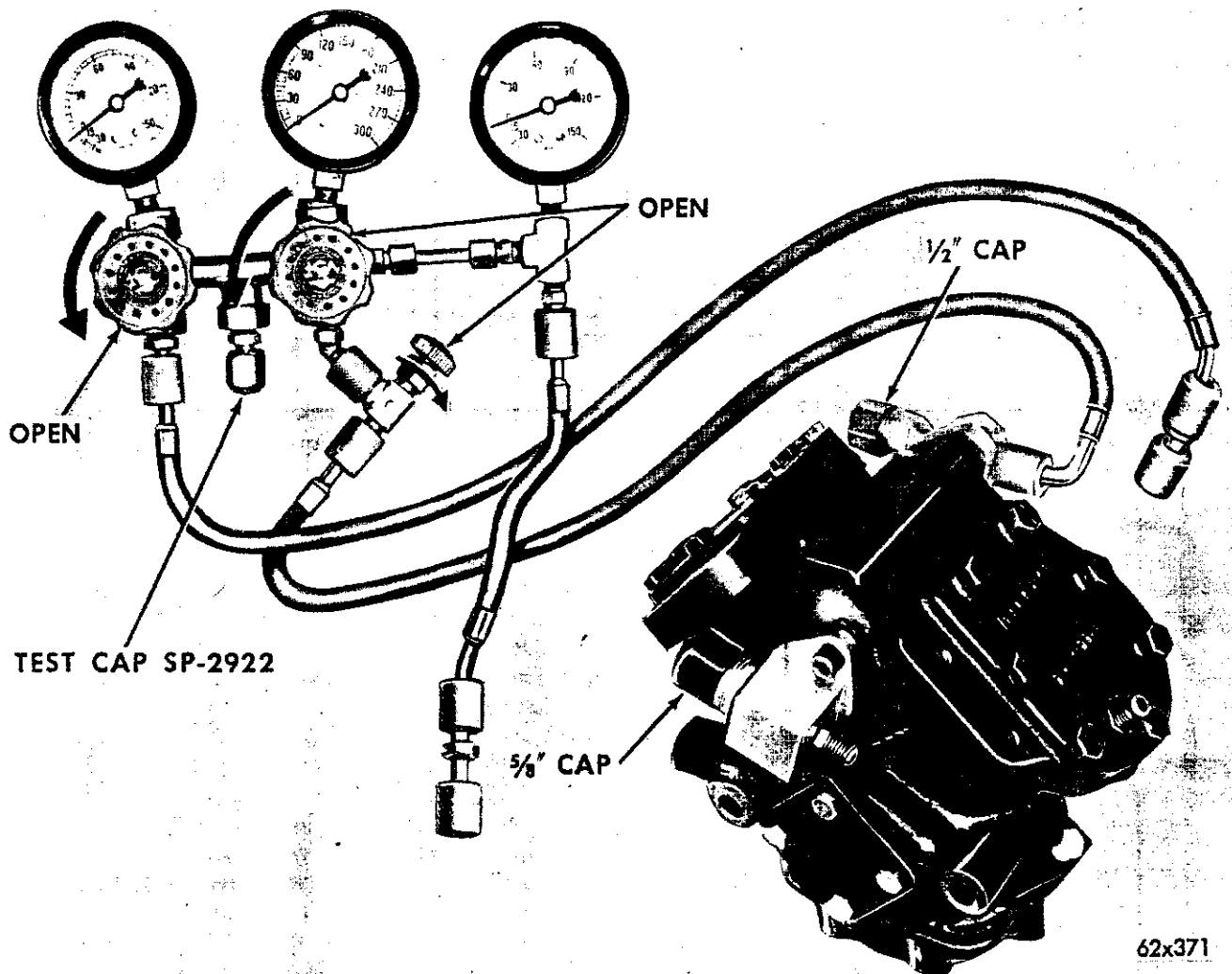

Fig. 25—Compressor Test Connections

**NOTE:** Be sure the test cap is perfectly clean. Particles adhering to the cap or the metering orifice can restrict the flow and cause false readings. Never use a wire or probe of any kind to clean the cap. Wash it with clean solvent and blow dry with compressed air.

(7) Make sure both the left and right gauge valves are open. The compressor can now be operated as an air pump. Air will be drawn in through the compressor inlet port, compressed and delivered (through the test hose attached to the discharge port) to the gauge set manifold. The compressor capacity is determined by noting the pressure registered at the discharge gauge when the compressor is driven at an engine speed of **exactly 500 rpm. THE TACHOMETER USED MUST BE ACCURATE.** The compressor capacity test results are dependent upon controlling the engine speed at **exactly 500 rpm.**

#### c. Test Pressures and Results

(1) Start the engine and adjust speed to exactly 500 rpm.

(2) Slowly close the left-hand gauge valve. Refer to Figure 26. All air delivered by the compressor will now be discharged through the metering orifice in the test cap. Pressure registered at the discharge gauge should build up to at least 190 psi.

(3) The load on the compressor may affect engine speed. If necessary, readjust the engine speed to **exactly 500 rpm.** The discharge pressure should build up to a minimum of 190 psi.

(4) Open the left-hand gauge valve momentarily

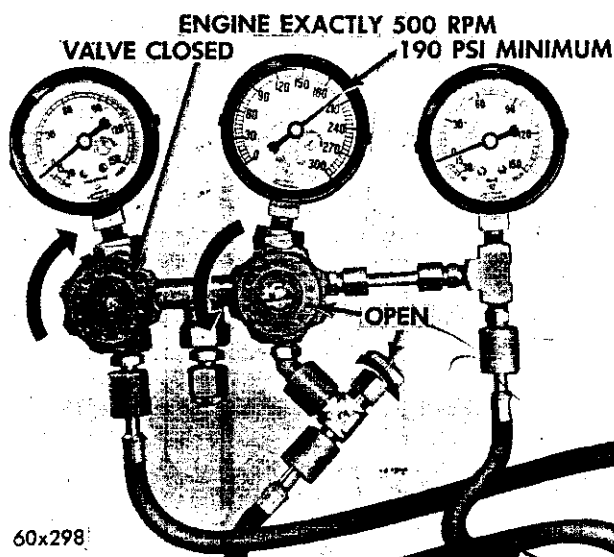

60x298

Fig. 26—Compressor Test Pressures

to allow the pressure to drop. Then close the valve to make sure the pressure again builds up to a minimum of 190 psi with the engine operating at 500 rpm.

#### CAUTION

**To prevent possible compressor damage from excessive heat, do not operate compressor more than a total of five minutes.**

If the compressor does not develop a minimum of 190 psi at 500 engine rpm, both the compressor valve plate assemblies and gaskets must be replaced. (See "Compressor Service Instructions"). After repair, the compressor capacity must be tested before charging the system and repeating the Over-All Performance Test.

A compressor that consistently builds up to a minimum of 190 psi at **exactly 500 engine rpm** is delivering rated capacity. Reconnect the evaporator suction line to suction fitting of compressor, and the discharge line to muffler discharge fitting. When connecting these lines use a new gasket, and lubricate both male and female threads and the turning surface of the female flare nut with refrigerant oil. Proceed with the "Expansion Valve Test".

#### TEST 8

##### THE EXPANSION VALVE TEST

The following procedure permits testing the expansion valve without removing it from the system. This test is made with the system completely discharged.

When testing the expansion valves on dual installations (front and rear units) **each expansion valve must be tested separately.** To test the expansion valve of the front unit, disconnect and cap the liquid and suction lines leading to the rear unit evaporator and expansion unit. To test the expansion valve of the rear unit, disconnect and cap the liquid and suction lines leading to the front unit evaporator and expansion valve. **IT IS ABSOLUTELY NECESSARY FOR THE COMPRESSOR TO PASS THE "COMPRESSOR CAPACITY" TEST BEFORE TESTING THE EXPANSION VALVE IN ITS INSTALLED POSITION.**

A compressor which does not pass the compressor capacity test may have leaking reed valves or a fractured head gasket. Such a leak would allow refrigerant gas, used in the expansion valve test, to leak from the discharge side of the compressor. An internal leak between the discharge and suction side of the compressor will upset the expansion valve test results.



### a. Test Preparations and Connections

(1) Close both the left and right gauge set manifold valves. Open the manifold needle valve.

(2) Install a  $\frac{1}{4}$ " connector and a  $\frac{1}{4}$ " tee fitting at the left side of the gauge manifold. Install the test cap (Tool SP-2922) on the tee fitting, and connect the test hose to the lower end of the tee fitting.

(3) Connect the other end of the suction test hose to the suction service port, using the special adapter to keep the suction service valve open.

(4) Connect the discharge test hose to the discharge service port, using a special adapter to hold this service valve open.

(5) Connect one end of the long test hose to the center of the gauge manifold, and the other end to the refrigerant dispensing manifold.

(6) Close two of the dispensing manifold valves

(turn clockwise). Open the remaining dispensing manifold valve (fully counterclockwise). Remove the protective cap from the opened valve.

(7) Screw a refrigerant can to the opened manifold valve, and tighten 6 to 8 foot-pounds maximum. Tighten the manifold locking nut against the shoulder of the can, again using 6 to 8 foot-pounds maximum to insure a good seal.

(8) Turn the manifold valve (above the refrigerant can) **completely clockwise** to puncture the can. This also closes the valve and seals the refrigerant in the can.

This completes all the test connections necessary for the expansion valve test. Check the test set-up against those illustrated in Figure 27.

Then, proceed with the following preparation steps:

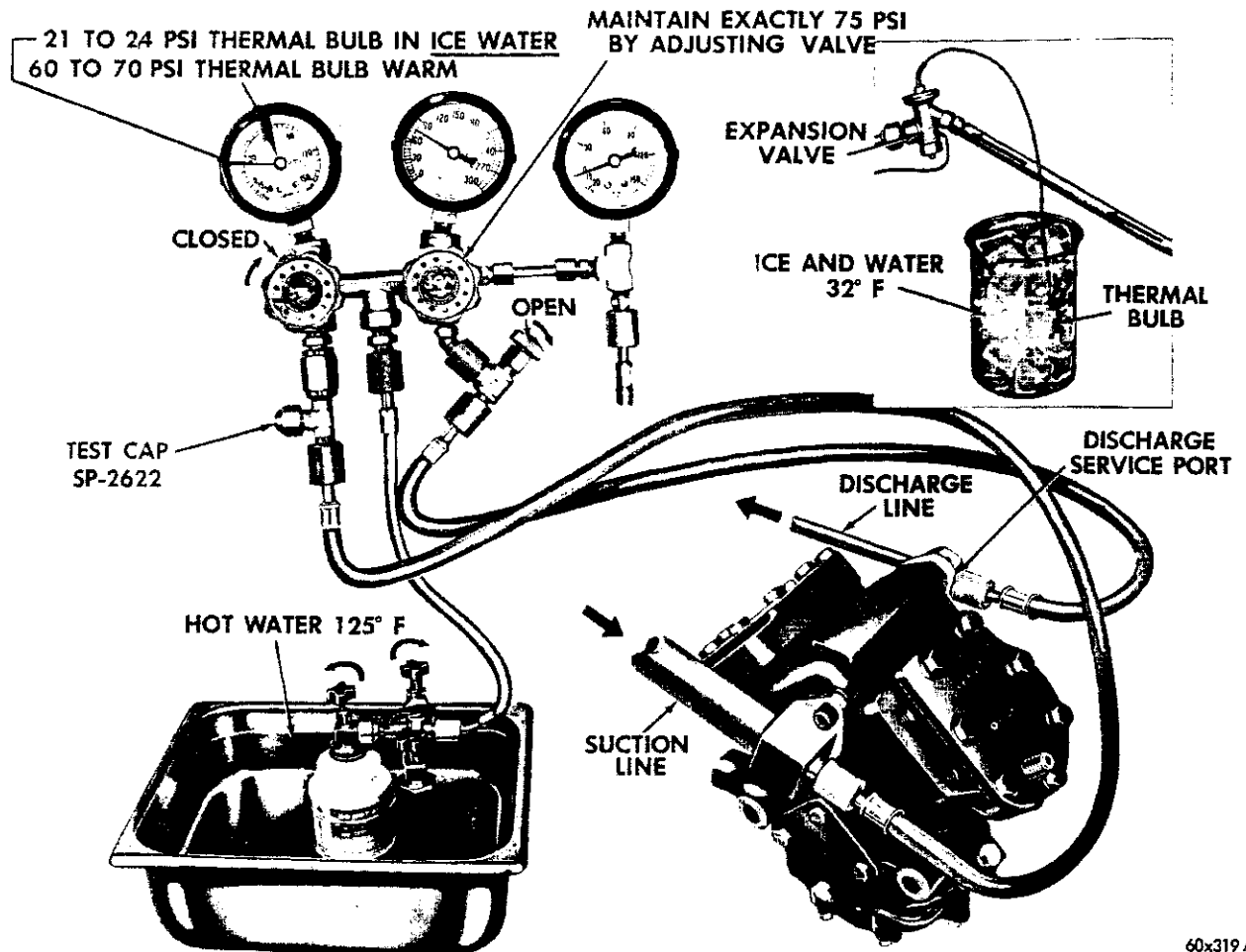

Fig. 27—Expansion Valve Test

(9) Remove the grommet retainer and grommet, located behind the expansion valve, from the evaporator housing.

(10) Remove the expansion valve thermal bulb from its well inside the evaporator housing.

(11) Prepare a large pan of water heated to 125 degrees F. and place the refrigerant can upright in the water. Use enough water to provide the heat necessary to insure ample refrigerant pressure throughout this test.

(12) Prepare a container of ice and water to provide a known temperature of 32 degrees F. This will be used to test the expansion valve in its "minimum flow" position.

**NOTE:** Under extreme conditions of high heat and humidity the temperature of the ice and water may not be reduced to 32 degrees F. Use a thermometer to test the actual temperature. If it is necessary to lower the temperature of the ice and water, add small quantities of salt while stirring until the desired temperature of 32 degrees F. is obtained.

#### b. Maximum Flow Test—Thermal Bulb Warm

(1) Warm the thermal bulb by holding it in your hand. This will produce the same effect as a warm evaporator . . . it will open the expansion valve for maximum flow.

(2) Open the refrigerant manifold valve (fully counterclockwise) to allow refrigerant vapor to flow to the gauge set manifold.

(3) Adjust the right-hand gauge set manifold valve to maintain exactly 75 psi on the discharge gauge.

(4) The suction gauge should register 60 to 70 psi for the front and rear units, the roof units, however, should be 65 to 75 psi, when pressure registered at the discharge gauge is maintained at exactly 75 psi. An expansion valve that passes this test is performing up to specifications for maximum flow. Next test for "minimum flow".

#### c. Minimum Flow Test—Thermal Bulb at 32° F.

(1) Close the right gauge valve to reduce pressure on the expansion valve. This will accelerate a movement of the valve toward the "minimum flow" position.

(2) Insert the thermal bulb in the container of ice and water. Use sufficient ice to insure a water temperature of 32° F. This will cause the expansion valve to move to the "minimum flow" position.

(3) Adjust the right gauge valve to maintain ex-

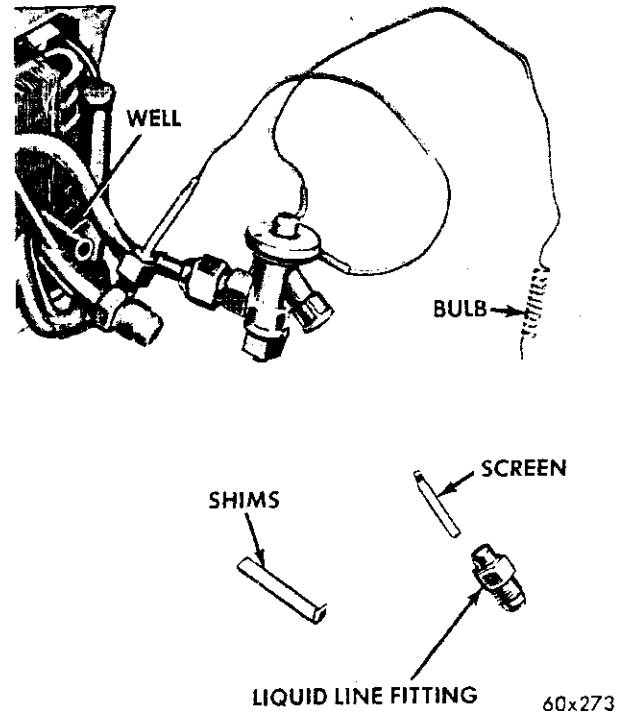

Fig. 28—Expansion Valve Details

actly 75 psi as registered at the discharge pressure gauge.

(4) The suction gauge should register 21 to 24 psi when discharge pressure is maintained at exactly 75 psi.

#### d. Test Results and Corrections

If the expansion valve does not pass these tests, it must be replaced. For detailed instructions on expansion valve replacement, refer to Paragraph "Expansion Valve".

An expansion valve which passes the above tests has the proper super heat setting, the proper pressure limit calibration, the correct rated capacity and has not lost its thermal bulb charge. Therefore, it will give satisfactory performance.

Since the system is without refrigerant, it is a good practice to remove the expansion valve inlet screen, clean it if necessary and reinstall it before charging the system. (Refer to Fig. 28). Clean the thermal bulb, the thermal bulb well and the brass thermal bulb wedging strips. Wedge the bulb into its well so that the brass strips wedge the bulb against the suction line. This fit must be mechanically tight and all surfaces clean to insure good thermal contact.

Install the rubber grommet and the grommet retainer at the evaporator housing. To put the system into operation it will be necessary to sweep, test for leaks, vacuum and recharge the system.

## SERVICE PROCEDURES

### SAFETY PRECAUTIONS

The refrigerant used in all 1962 air-conditioning installations is Refrigerant 12. It is transparent and colorless in both the liquid and vapor state. Since it has a boiling point of 21.7 degrees F. below zero, it will be a vapor at all normal temperatures and pressures. It is a safe refrigerant. The following precautions, however, must be observed when handling Refrigerant 12.

### CAUTION

Wear safety goggles when servicing the refrigeration system. Refrigerant 12 evaporates so rapidly at normal atmospheric pressures and temperatures that it tends to freeze anything it contacts. For this reason, extreme care must be taken to prevent any liquid refrigerant from contacting the skin and especially the eyes.

Always wear safety goggles (Tool C-3355) when servicing the refrigeration part of the air-conditioning system. Keep a bottle of sterile mineral oil and a weak solution of boric acid handy when working on the refrigeration system. Should any liquid refrigerant get into the eyes, use a few drops of mineral oil to wash them out. Refrigerant 12 is rapidly absorbed by the oil. Next, wash the eyes with the weak solution of boric acid. Call your doctor immediately even though irritation has ceased after first aid treatment.

**NOTE:** Do not heat Refrigerant 12 above 125 degrees F. In most instances, moderate heat is required to bring the pressure of the refrigerant in its container above the pressure of the system when charging or adding refrigerant. A bucket or large pan of hot water not over 125 degrees F. is all the heat required for this purpose.

Keep Refrigerant 12 containers upright when charging the system.

Do not permit liquid refrigerant to touch bright metal parts.

### HANDLING TUBING AND FITTINGS

Kinks in the refrigerant tubing or sharp bends in the refrigerant hose lines will greatly reduce the capacity of the entire system.

Use a suitable tube bender (Tool C-3362) when bending the refrigerant lines to avoid kinking. Never attempt to rebend formed lines to fit. Use the correct line for the installation you are servicing.

Dirt and moisture can enter the system when it is opened for repair or replacement of lines or components. The following precautions must be observed.

The system must be completely discharged before opening any fitting or connection in the refrigeration system.

A good rule for the flexible hose lines is keep the radius of all bends at least 10 times the diameter of the hose. The flexible hose lines should be routed so that they are at least 3 inches from the exhaust manifold.

Always use new copper gaskets. When reconnecting the lines, apply a liberal coating of refrigerant oil (Fig. 29) to the threads of both parts, particularly to the flare surfaces of the tube and the nut. This will allow the flare fittings to seat squarely and provide proper tightening.

The use of proper wrenches (Tools C-3358 and C-3363) when making connections is very important. Improper wrenches or improper use of wrenches can damage the fittings. Always use two wrenches when loosening or tightening flare tube fittings to prevent distorting of lines and components.

Cap or plug all lines and fittings as soon as they are opened to prevent the entrance of dirt and moisture. All lines and components in parts stock should be capped or sealed until they are ready to be used.

Only refrigeration oil should be used in the system or on the fittings and lines.

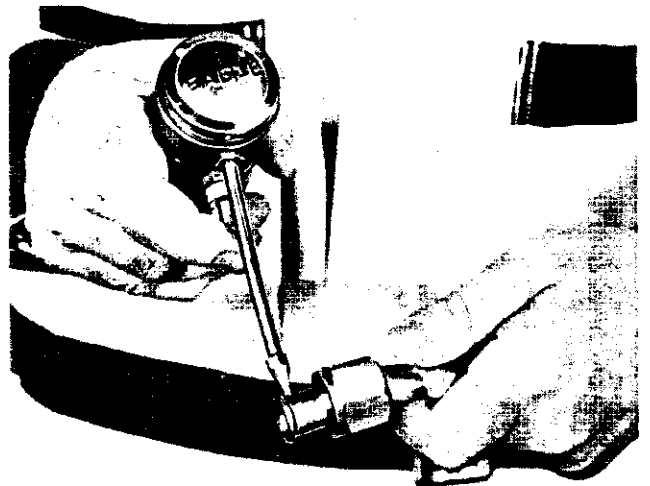

60x884

Fig. 29—Lubricate with Refrigerant Oil

### COMPRESSOR DRIVE BELT ADJUSTMENT

Satisfactory performance of the air-conditioning system is dependent upon the drive belt condition and tension. If the proper tensions are not maintained, belt slippage will greatly reduce air-conditioning performance and drive belt life. To avoid such adverse effects, the following service procedure should be followed:

(1) Any belt that has operated for a minimum of a half-hour is considered to be an "in use" belt. Adjust air-conditioning drive belts at the time of new-car preparation. If the torque method is used, tension should be 40 foot-pounds for ALL MODELS.

If the deflection method is used, deflection should be  $\frac{3}{8}$  inch at the mid-point under a 5-pound load for ALL MODELS.

(2) Measure the drive belt tension at regular service intervals, using the deflection method, and readjust as needed.

(3) On all new-belt installations, new-belt tension specifications should be used when the belt is first installed to obtain the proper tension. Thereafter, these replacement belts should be serviced according to the above procedure. Always replace belts in pairs, otherwise the old belt will have insufficient tension and the load will be primarily on the new belt. The torque method of adjusting new belts is preferred. Proper tension for new belts is 60 foot-pounds for all models.

(4) If the deflection method is used, deflection at mid-point should be  $\frac{1}{4}$  inch for all models.

### ANTIFREEZE RECOMMENDATIONS

The Air-Conditioning System requires the engine's cooling system to be protected to  $+15^{\circ}$  F. with a permanent type antifreeze for summer operation.

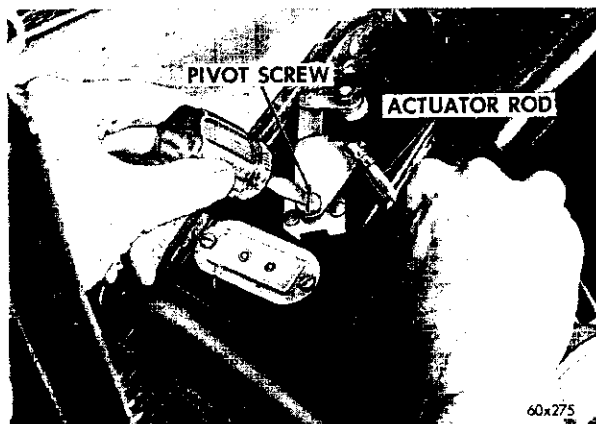

Fig. 30—Heater By-Pass Door Adjustment

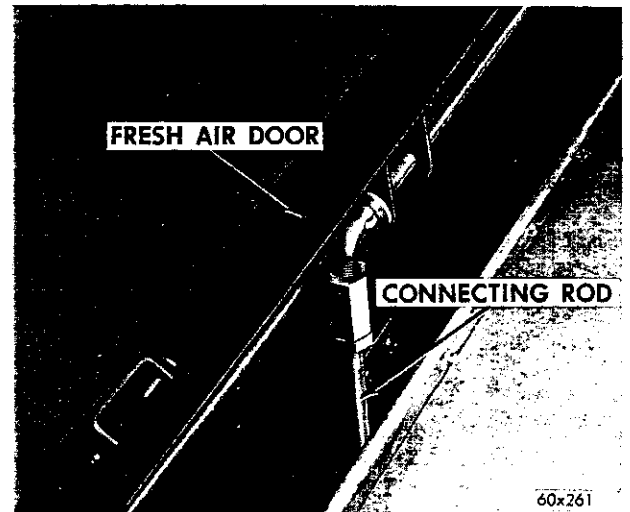

Fig. 31—Fresh Air Door Connecting Rod

This is to prevent freezing of the coolant in the heater core.

### RADIATOR PRESSURE CAP REQUIREMENTS

It is absolutely necessary for the 1962 air-conditioned vehicles to be equipped with a 15 to 16 psi radiator cap.

### VACUUM CONTROL SYSTEM ADJUSTMENTS AND TESTS

#### a. Heater Bypass Door Adjustment

Press the "DEFROST" or "HEAT" button. The bypass door should be fully closed and the vacuum actuator should move the over-center lever into a straight line with the pivot screw. To adjust the over-center linkage, loosen the pivot lever screw (Fig. 30). Slide the pivot and screw in its slot as you push the actuator rod rearward to close the bypass door completely. Hold the actuator rod and tighten the pivot screw to maintain this adjustment.

#### b. Recirculation and Fresh Air Door Linkages

Inspect and correct any binding of the recirculating door over-center lever, hinges and fresh air door connecting rod. To adjust the fresh air door connecting rod, remove the cowl inlet grille, and push the "FRESH COOL" button in. The fresh air door will open, and the connecting rod (Fig. 31) is then readily accessible.

The connecting rod is provided with a turnbuckle nut and lock nut. The length of the rod can be adjusted by using two  $\frac{1}{16}$  inch open-end wrenches. The fresh air door should be adjusted to give the

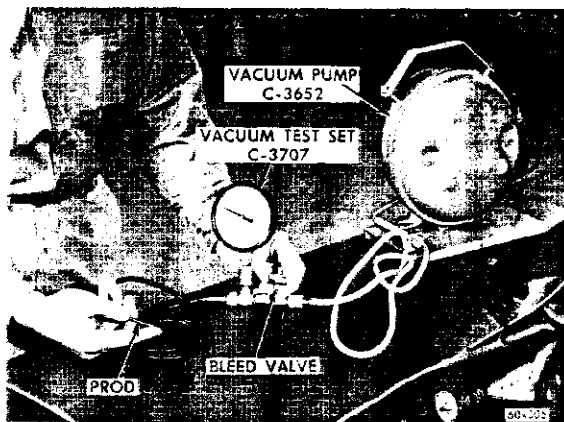

Fig. 32—Adjust Vacuum Test Bleed Valve

minimum possible opening when the recirculating door is completely closed. Push in the "MAXIMUM COOL" button and inspect to see that the fresh air door moves to its fully closed position.

#### c. Vacuum Control System Test

The test of the push-button operation determines whether or not the vacuum and electrical circuits are properly connected and the controls are functioning properly. However, it is possible that a vacuum control system that operates perfectly at the high vacuum provided at engine idle speed may not function properly at high engine speeds. Before starting this test, stop the engine. Make certain that the vacuum source hose at the engine intake manifold is tight on its connector.

Start the vacuum pump (Tool C-3652) and connect to the vacuum test set (Tool C-3707). Adjust the bleed valve on the test set to obtain exactly 8 inches of vacuum, with a finger blocking the prod on the

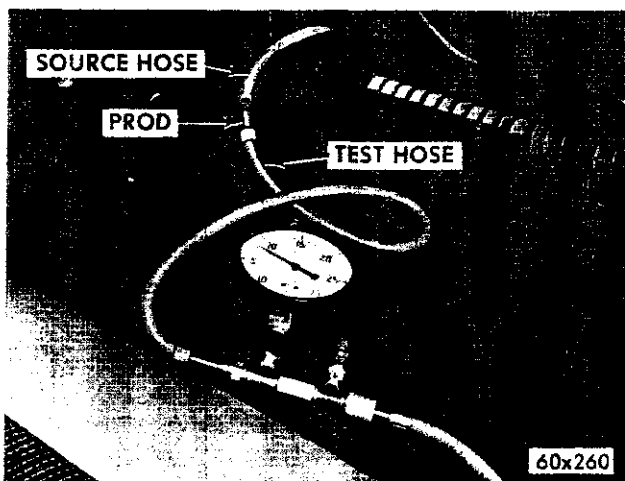

Fig. 33—Push Button Vacuum Test

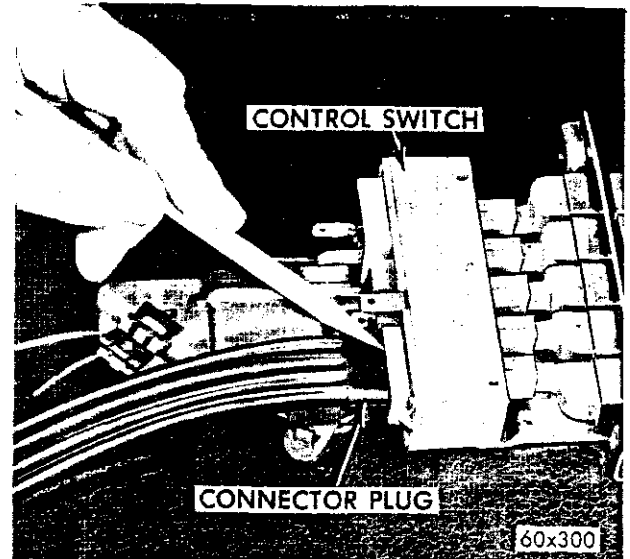

Fig. 34—Connector Plug Installed

end of the test hose (Fig. 32).

It is absolutely essential that the bleed valve be adjusted so the vacuum gauge pointer will return to exactly 8 inches when the prod is covered by a finger. Otherwise a false reading will be obtained when the control circuit is tested.

#### CAUTION

Alternately release and reblock the hose prod several times. Make sure the bleed valve is adjusted so the vacuum gauge pointer returns to exactly 8 inches of vacuum when the prod is covered with a finger.

Disconnect the engine vacuum source hose (Fig. 33) at the plastic junction connector under the instrument panel, and insert the vacuum tester hose prod into the source hose leading to the control switch.

Start the test by pushing the "H" or heat button. The vacuum tester gauge needle will drop until the actuator has operated, and then will return to 8 inches. Note how much the vacuum drops below 8 inches. Continue to push buttons; "OFF", "MAX. COOL", "FRESH COOL", "DEFROST" and "HEAT" allowing time for actuators to operate after each button is pushed, and note the vacuum drop below 8 inches after each operation. The maximum allowable vacuum drop below 8 inches after each operation is  $\frac{3}{4}$  inch.

If the vacuum drop is more than  $\frac{3}{4}$  inch, first recheck the tester for reading exactly 8 inches. If correct, inspect the fit of the 7-hole hose connector plug on the control switch (Fig. 34). This plug must be

positioned all the way on the 7 prods on the control switch.

### CAUTION

Do not use lubricant on the switch prods or in the holes in the plug, as lubricant will ruin the vacuum valve in the switch. If it is impossible to properly position the connector plug all the way on the switch prods, put a drop or two of clean water in the holes of the connector plug. This will allow the plug to slide completely on the switch prods.

#### d. Retest

If vacuum drop is now within limits, proceed with the over-all performance test. If the vacuum drop is still in excess of  $\frac{3}{4}$  inch, remove the connector plug from the switch. Insert the vacuum test prod alternately in each of the connector holes except the source hose connector hole (Fig. 35). Note the amount of vacuum drop below 8 inches after each actuator has operated. If the vacuum test gauge comes back to 8 inches at each of the 6 holes, the hoses and actuators aren't leaking. The control switch is faulty and must be replaced. If excessive vacuum drop shows up at one or more holes in the connector block, isolate the faulty hose or actuator.

If the vacuum drop occurs at numbers 5 or 7 holes, first check the tee connectors under the instrument panel that tie numbers 5 and 7 hoses to the bypass door and deflector hoses. If the tee connections are all right, inspect the hose connections to the actuator involved. Then test whether the actuator or hose is a fault; use the test hose on the actuator involved (Fig. 36).

A leak in a hose may be detected with the leak tester by running fingers along the hose and watch-

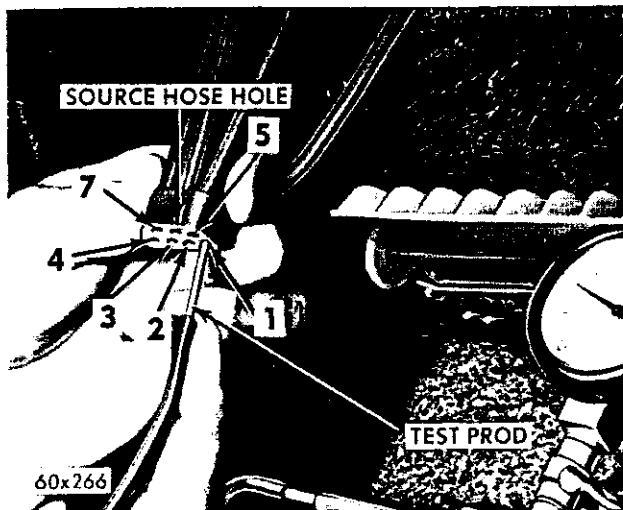

Fig. 35—Vacuum Tube Assembly Test

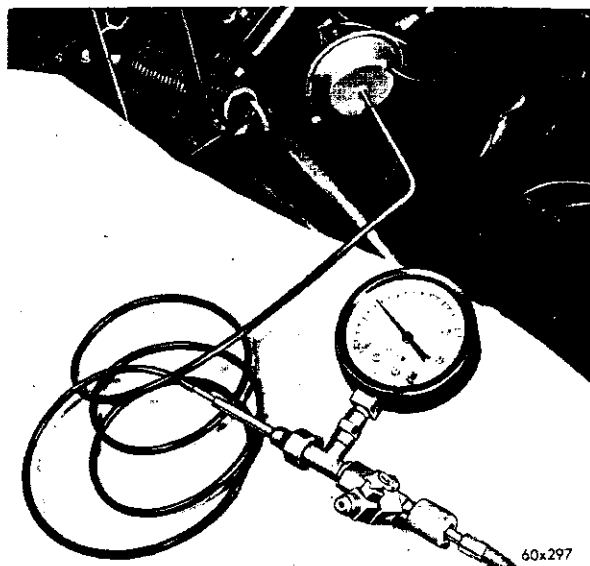

Fig. 36—Vacuum Actuator Test

ing the vacuum gauge reading. A faulty spot may be cut out and the hose spliced, using  $\frac{1}{8}$ -inch 00 copper tubing.

A vacuum drop in excess of  $\frac{3}{4}$  inch below the 8 inches needed in this test would not interfere with the engine operation, other than perhaps to cause a rough idle. It could, however, interfere with the proper operation of the air-conditioning and heating controls at high speeds and during acceleration.

### SERVICING THE MAGNETIC CLUTCH

The magnetic clutch (Fig. 37) uses a stationary electromagnet attached to the compressor. Since the electromagnet does not rotate, the collector rings and the brushes are eliminated.

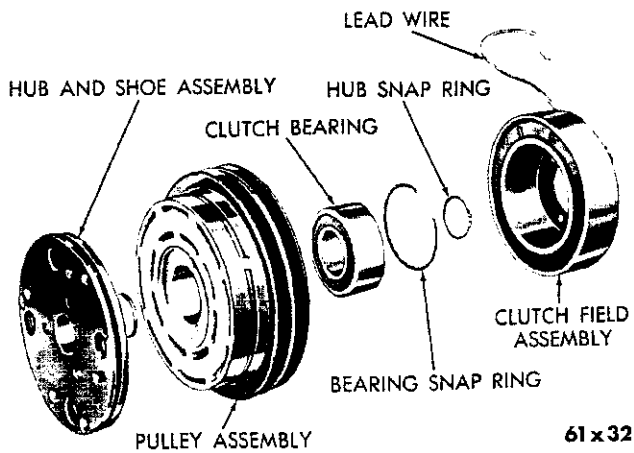

Fig. 37—Magnetic Clutch—Stationary Field Type

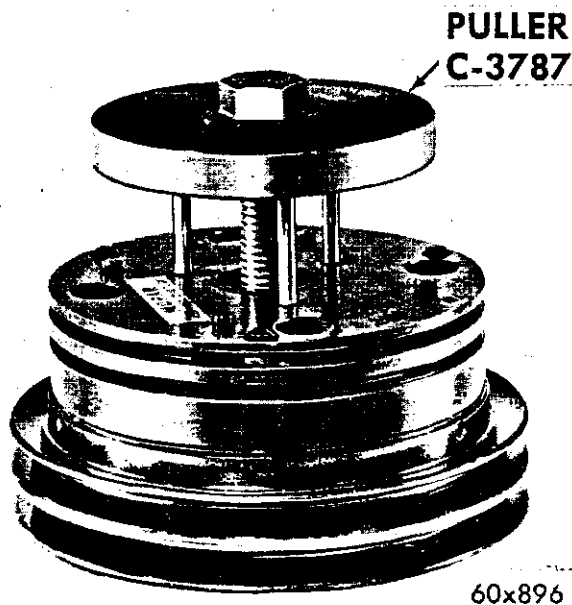

Fig. 38—Removing the Hub and Shoe Assembly

#### TESTING ELECTROMAGNET CURRENT DRAW

To test the coil for a short or open circuit, connect an ammeter (0-10 ampere scale) in series with a fully charged 12-volt battery and the field coil lead. The current draw at 12 volts should be 2.5 to 2.9 amperes.

##### a. Removal

(1) Loosen and remove the belts. Disconnect the field coil lead wire.

(2) Remove the special locking bolt and the washer from the compressor crankshaft at the front

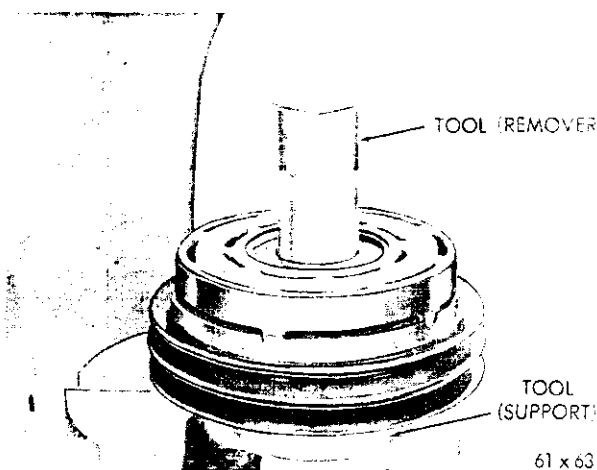

Fig. 39—Removing the Bearing from the Pulley Assembly

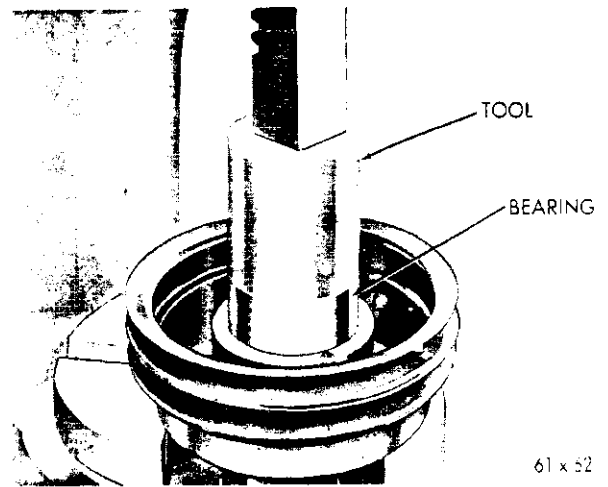

Fig. 40—Installing a New Bearing in the Pulley Assembly

center of the clutch.

(3) Insert a  $\frac{5}{8}$ "-11x2 $\frac{1}{2}$ " cap screw into the threaded portion of the hub and shoe assembly.

(4) Support the clutch with one hand, then tighten the cap screw until the clutch is removed.

(5) Remove the three hex field coil assembly mounting screws and lift off the assembly.

##### b. Disassembly

(1) Remove the small snap ring from the drive hub with Tool C-3128 or equivalent.

(2) Install the drive hub puller Tool C-3787 aligning the three pins of the Tool in the three holes in the hub and shoe assembly. Tighten the hex head bolt down until the drive hub is removed from the bearing (See Fig. 38).

(3) Remove the bearing snap ring from the pulley assembly.

(4) Place the pulley assembly on an arbor press, with the pulley side down, and the bearing hub centered on Tool C-3835. Install the Tool SP-3496 on the inner race of the bearing, and press the bearing from the pulley assembly. (See Fig. 39).

**NOTE:** A new bearing must be installed every time the magnetic clutch is disassembled.

##### c. Assembly

(1) Install the pulley assembly with the pulley side up on an arbor press and insert a new bearing into the bore. Install the Tool C-3807 against the bearing and press into position.

(2) Install the pulley assembly with pulley side facing down on Tool C-3807.

(3) Start the drive hub into the inner bearing race, and press the hub into position with an arbor press. (See Fig. 40).

(4) Install bearing snap ring and hub snap ring.

#### CAUTION

The pulley assembly and hub assembly are mated parts. They are burnished at the factory before shipment. No attempt should be made to replace either unit separately as this may reduce the initial torque of the clutch.

#### d. Installation

(1) Install the field assembly on the base of the compressor bearing housing. Make sure the coil assembly is positioned so that the lead wire points up and can be routed between the compressor cylinder heads. Install the three mounting screws and tighten to 17 inch-pounds torque.

(2) Insert the woodruff key in the crankshaft.

(3) Install the clutch assembly onto the crankshaft.

(4) Install the washer and a new self-locking bolt, and tighten to 20 foot-pounds torque.

(5) Connect the field lead wire.

(6) Install the belts, tighten to the specified tension.

#### SERVICING THE COMPRESSOR

The compressor is a two-cylinder, reciprocating-type designed specifically for the Chrysler Air-Conditioning System. Service parts are available so that the compressor can be repaired in the field.

Figure 41 is a disassembled view of the compressor with the nomenclature of the parts. Some parts are serviced individually and some are serviced in packages which include two or more service parts, refer to the parts book for this information.

#### CAUTION

The refrigerant oil used in the compressor is carried through the entire system by the refrigerant. Some of this oil will be trapped and retained in the system when the refrigerant is discharged for testing or

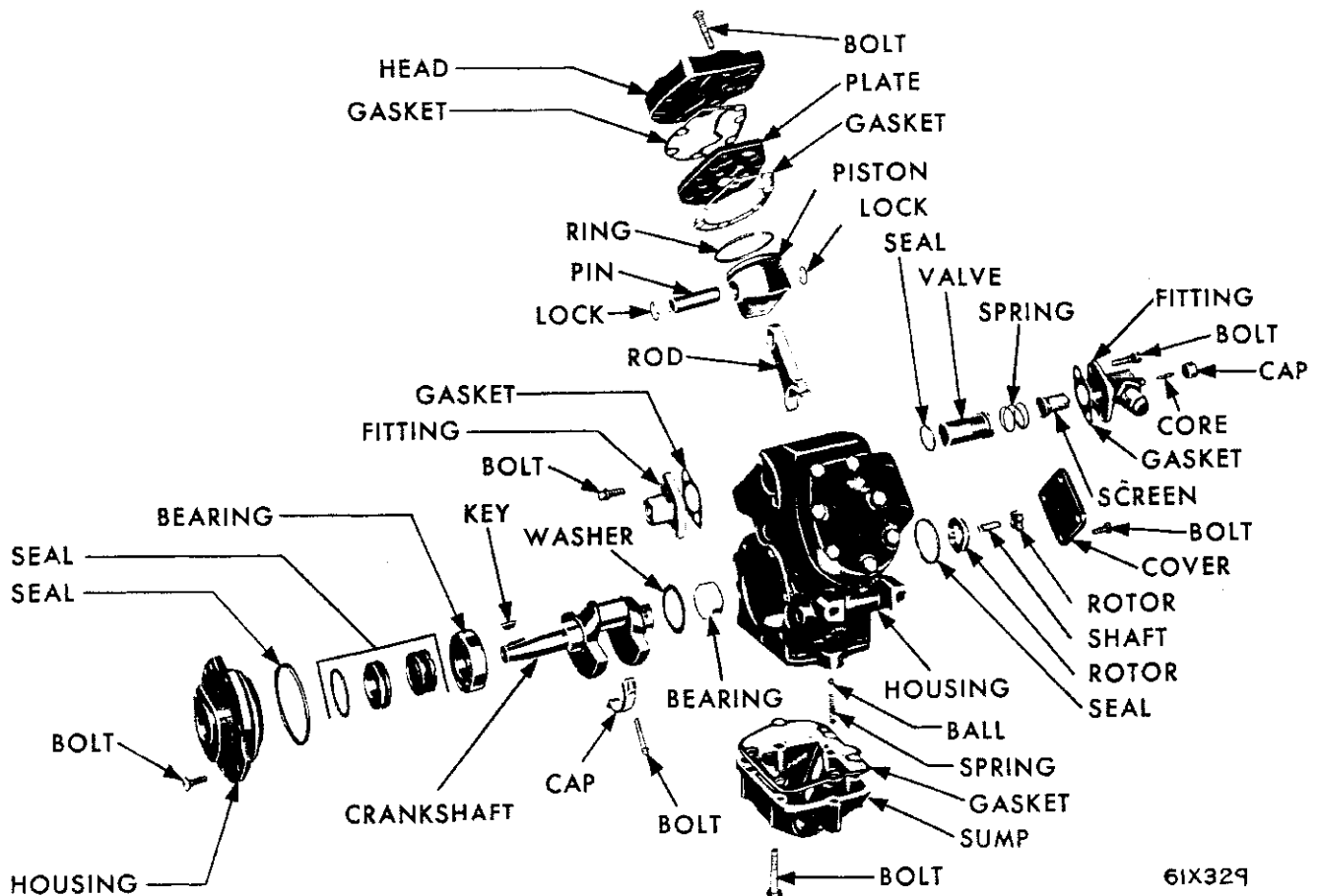

61X329

Fig. 41—Compressor (Disassembled)



unit replacement. If the compressor is to be removed for repair or replacement, measure the refrigerant oil level in the compressor before the compressor is removed from the vehicle so that the same level can be established when the new or repaired compressor is installed on the vehicle. Too much refrigerant oil in the system can cause abnormal operating pressures and reduce the performance of the entire system.

Complete disassembly and assembly of the compressor must be performed with the compressor removed from the vehicle. On some models however, the valve plate and crankshaft gas seal assemblies can be repaired with the compressor installed on the vehicle.

#### CAUTION

The system must be completely discharged before attempting to perform any disassembly or repair service to the compressor.

Cleanliness is extremely important. The work area must be clean and free of air-borne dust and dirt. All parts must be thoroughly cleaned and blown dry before reassembly.

Do not use air to dry the crankshaft front main bearing. Wash the bearing in clean mineral spirits and shake out all excess cleaning fluid. Saturate the bearing with clean refrigerant oil and assemble immediately. Any dirt in the front main bearing assembly will cause noisy operation and possible damage to the bearing.

#### CAUTION

Before reassembly of any unit, all contact surfaces must be liberally coated with clean refrigerant oil.

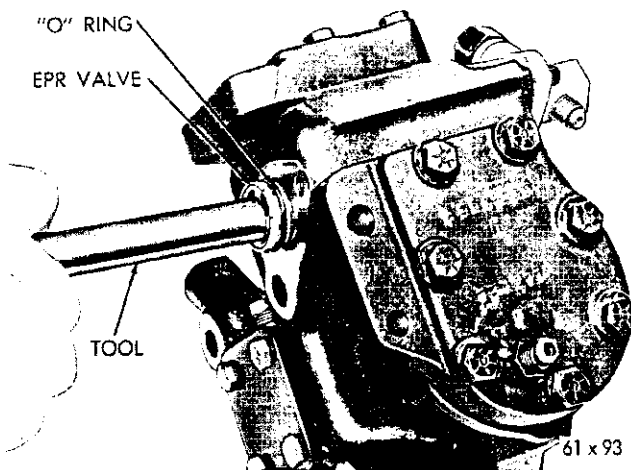

Fig. 42—Removing the EPR Valve

Refrigerant oil must be kept in a sealed container until ready for use to prevent entrance of moisture and dirt. Never use engine oil as a substitute for refrigerant oil.

#### EPR VALVE

##### a. Removal

(1) Remove the two EPR Valve suction line fitting bolts, the fitting which also contains the compressor suction screen, spring, and the gasket.

(2) Remove the EPR Valve and "O" ring from the compressor using Tool C-3822, by rotating the valve counterclockwise slightly, as shown in Figure 42.

##### b. Installation

(1) Install the "O" ring on the EPR Valve.

(2) Lubricate the "O" ring with refrigerant oil and install the EPR Valve in the compressor with Tool C-3822 and rotating the valve counterclockwise.

(3) Install the compressor suction screen in the EPR Valve suction line fitting.

(4) Install the suction line fitting gasket, spring, fitting, and attaching bolts.

#### COMPRESSOR

##### a. Removal

(1) Discharge the system. (Refer to "Discharging the System".)

(2) Measure and record the refrigerant oil level so that the oil level of a replacement or repaired compressor can be adjusted to the exact level registered on the dipstick of the compressor removed from the vehicle.

(3) Remove the suction line from the compressor fitting and disconnect the discharge line from the muffler fitting.

#### CAUTION

Plug or cap all the lines as soon as they are disconnected to keep the moisture out of the system.

(4) Disconnect the magnetic clutch-to-control unit wire.

(5) Loosen and remove the compressor pulley belts.

(6) Remove the compressor-to-bracket attaching bolts, and remove the compressor.

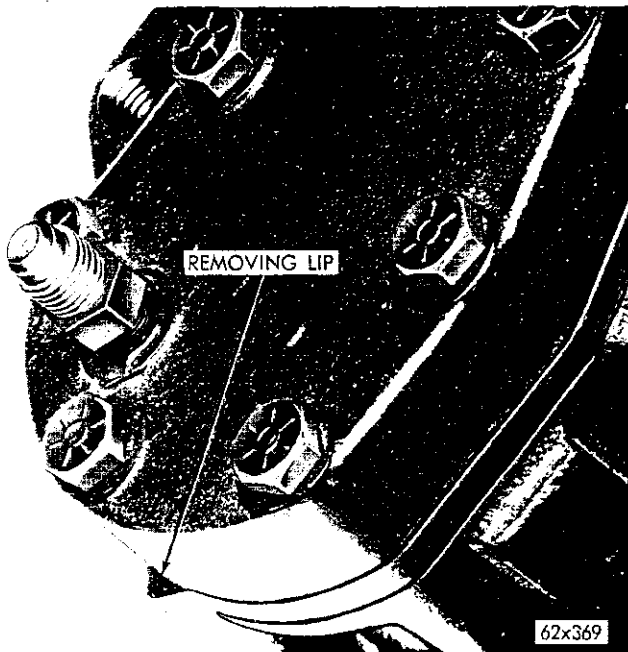

Fig. 43—Valve Plate and Head Removing Lip

**b. Installation**

- (1) Install the compressor to the bracket, and tighten the attaching bolts.
- (2) Install the compressor pulley belts.
- (3) Connect the magnetic clutch-to-control-unit wire.
- (4) Remove the caps or plugs and connect the suction line to the compressor, and connect discharge line to the muffler fitting.

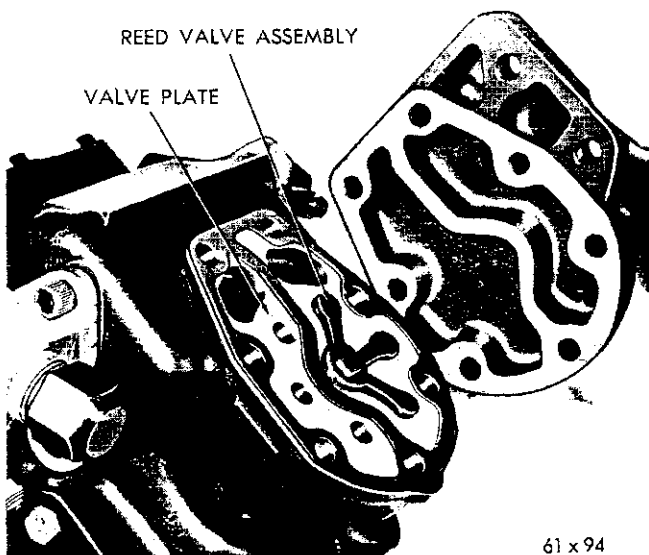

Fig. 44—Valve Plate—Installed Position

**CAUTION**

When replacing the compressor assembly, the crankshaft should be rotated by hand at least two complete revolutions, to clear oil accumulation from the compressor head before the clutch is energized to avoid damaging the compressor reed valves.

**NOTE:** After the compressor is installed, it is imperative that the oil level in the compressor be adjusted to the level registered before removing the compressor. If the original oil level is not known, adjust the level to 2 inches.

**CYLINDER HEAD AND VALVE PLATE ASSEMBLY**

**a. Removal**

- (1) Remove the cylinder head bolts, the head and valve plate assembly. If the plate does not separate from the head, tap the removing lip on the valve plate lightly with a plastic hammer (see Fig. 43). Do not pry apart.

**b. Inspection**

After removal of the head, plate and gaskets, examine the valves. If the valves are broken and damage extends to the cylinder bores, examine the bores to see if they can be repaired by removing light scoring, scuffing or scratches with a crocus cloth. After conditioning the cylinder bores, clean the surfaces of the cylinder block, valve plate and head thoroughly with mineral spirits.

Use care to remove all shreds of old gasket from

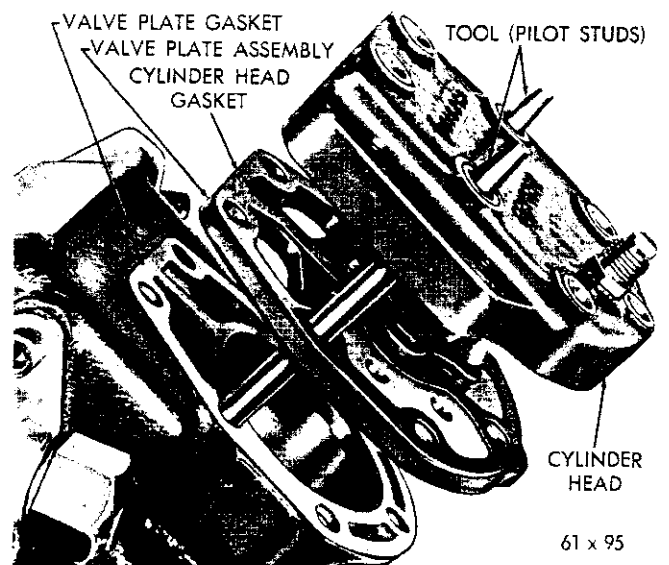

Fig. 45—Installing the Valve Plate and the Cylinder Head

plate, block and head surfaces. Clean attaching stud holes in the block. If the valve plate or cylinder head is damaged, replace, using a complete compressor valve plate replacement package.

#### c. Installation

(1) The valve plate and the cylinder head must be assembled with the reed assembly, as shown in Figure 44.

(2) Dip the gaskets in clean refrigerant oil. Using the pilot studs as a guide, install the valve plate gasket, valve plate, cylinder head gasket and cylinder head, as shown in Fig. 45.

(3) Install the attaching bolts. Tighten each bolt alternately and evenly 23 to 27 foot-pounds torque.

### PISTON AND CONNECTING ROD

#### a. Removal

- (1) Drain the oil from the compressor.
- (2) Remove the sump attaching bolts.
- (3) Separate the sump from the case by tapping with a plastic hammer being careful not to distort the oil pressure relief spring.
- (4) Remove the oil relief spring and (rubber) ball from the crankcase.
- (5) Remove the cylinder heads and the valve plates.

**NOTE:** Before removing the pistons, rods or rod caps, mark all parts to insure reassembly in the original position.

(6) Remove the rod caps; remove the piston and rod assembly from the cylinder.

#### b. Inspection

Inspect the piston and rings for the score marks. Inspect the rod bearing for pits and for chipping. Replace the parts if damaged.

#### c. Installation

(1) Remove the bearing cap and install the piston in the bore. Use piston ring compressor to prevent ring damage.

(2) Install the bearing caps, and tighten screws 52 to 56 inch-pounds torque. Be sure each cap is installed in its original position.

(3) Install the valve plates and the cylinder heads.

(4) Turn the compressor upside down. Install the pilot studs, gasket, oil pressure relief ball and spring.

(5) Install the sump over the pilot studs (Fig.

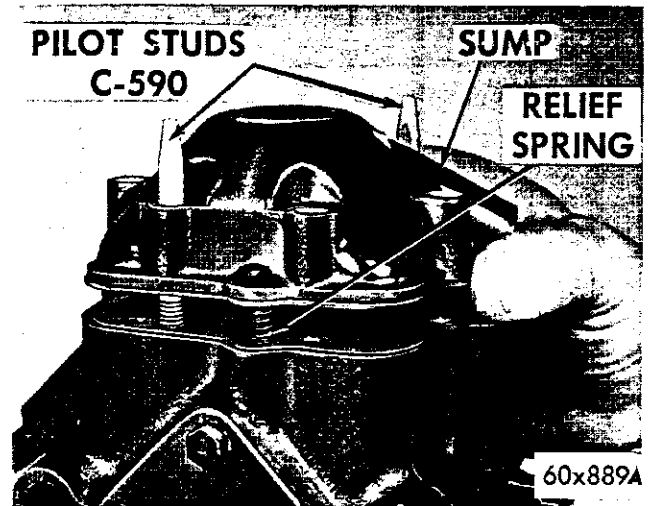

Fig. 46—Installing the Sump

46), making sure that the oil pressure relief spring depresses uniformly as the sump is lowered on the case.

(6) Tighten the sump bolts finger tight to prevent spring misalignment, then tighten 15 to 19 foot-pounds torque.

(7) Refill with new refrigerant oil after the compressor is installed on vehicle. Do not re-use the oil that was previously drained.

### CRANKSHAFT BEARING HOUSING AND GAS SEAL

#### a. Removal

- (1) Remove the crankshaft housing seal bolts.
- (2) Remove the bearing housing from the case, using two screwdrivers inserted in the slots provided to pry the housing from the case. (See Fig. 47).
- (3) Remove the crankshaft bearing housing seal face plate from the bearing housing. This is part of the gas seal replacement package and must be replaced when the gas seal assembly is replaced.

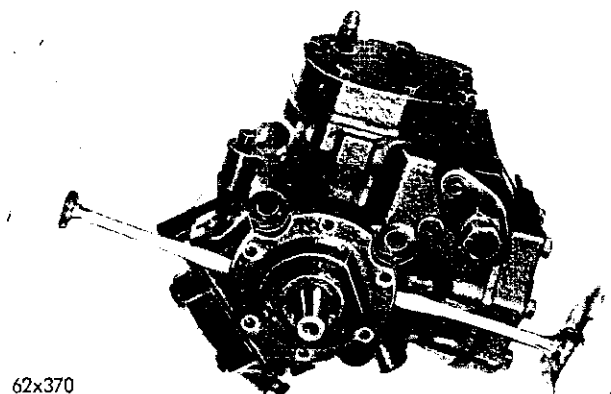

Fig. 47—Removing the Crankshaft Bearing Housing

- (4) Remove the gas seal from the crankshaft.

#### b. Installation

The crankshaft gas seal replacement package consists of the crankshaft gas seal assembly and the crankshaft bearing housing seal face plate. Two types of crankshaft seals are supplied for service, as shown in Fig. 48. If the replacement package contains the cartridge-type seal, follow the entire installation procedure given below. If the replacement package contains the unitized-type seal, steps 1, 2, and 4 will not apply.

(1) Before installing the cartridge-type gas seal assembly, inspect the assembly to make sure that tangs index in slots of mating part. This will insure the proper spring action. The carbon seal must be assembled as shown in Fig. 48.

(2) Hold the seal firmly on the outside edge to prevent it from rotating out of the index slots.

(3) Lubricate the crankshaft with refrigerant oil. Slide the seal on the crankshaft with the smooth (carbon seal) surface up, or toward the front of the compressor.

(4) When the seal bottoms against the crankshaft bearing, inspect the indexing of tangs again by pressing down with thumbs to see if it has the proper spring action. (Refer to Fig. 49).

(5) Lubricate and install the crankshaft bearing housing seal face plate with the smooth (micro-finish) side up. Use a sleeve with the minimum inside diameter of  $1\frac{3}{8}$  inches to avoid damaging the micro-finish sealing surface of the face plate. Tap

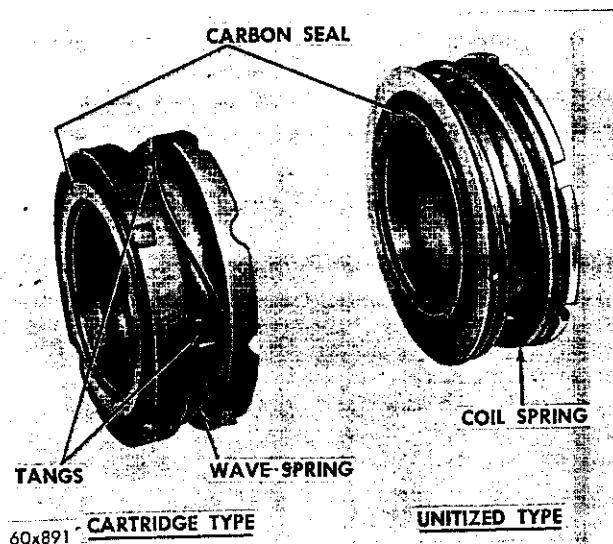

Fig. 48—Gas Seal Identification

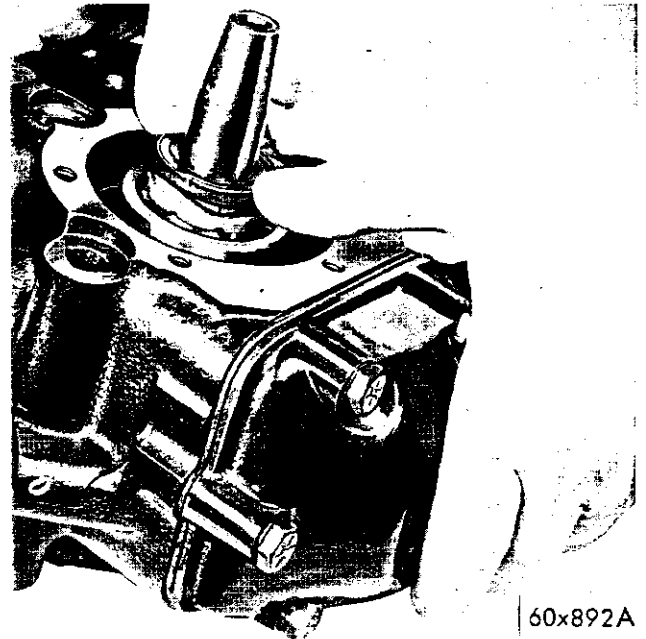

Fig. 49—Inspect the Indexing of Tangs

sleeve lightly until the seal face is fully seated in the housing.

(6) Install the bearing housing oil seal, using plenty of refrigerant oil.

(7) Install the housing, making sure that it is in proper alignment with the screw holes. The gas seal assembly may be damaged if the bearing housing is rotated after the housing seal contacts the carbon seal.

(8) Install the bolts and tighten 10 to 13 foot-pounds torque.

#### CRANKSHAFT AND BALL BEARING

##### a. Removal

(1) Remove the cylinder heads and the valve plates.

(2) Remove the pistons and connecting rods.

(3) Remove the crankshaft bearing housing and gas seal.

**NOTE:** The pistons and rods must be completely removed before the crankshaft removal.

(4) Remove the crankshaft and thrust washer from the crankcase.

(5) To remove the crankshaft ball bearing, use a small arbor press. Make sure the bearing is properly supported before pressing the bearing from the shaft.

**b. Inspection**

Clean and inspect all the parts. Replace the questionable parts as required. If the crankshaft ball bearing is in good condition and clean, protect it against entry of dirt and re-use it. If the bearing is serviceable but dirty, or there is evidence of dirt, clean it carefully with mineral spirits and shake dry. Saturate the bearing with clean refrigerant oil and assemble immediately. If a new bearing is to be installed, leave it wrapped in its protective package until ready for installation. **DO NOT WASH A NEW BEARING ASSEMBLY BEFORE INSTALLATION.**

**c. Installation**

- (1) Press the crankshaft ball bearing on the crankshaft using a sleeve which bears on the inner race only.
- (2) Install the crankshaft, making sure that the thrust washer is on the rear bearing journal before placing the crankshaft in the crankcase.
- (3) Rotate the crankshaft to engage the oil pump shaft in the crankshaft slot.
- (4) Install the gas seal and crankshaft bearing housing. Use a suitable tool, as shown in Fig. 50 to assure the free axial movement.
- (5) Install the pistons and connecting rods.
- (6) After the pistons and connecting rods are installed, turn the crankshaft to check freeness. The shaft should turn without binding.
- (7) Install the oil sump, valve plates and the cylinder heads.

**OIL PUMP****a. Removal**

To remove the oil pump, it is not necessary to drain the refrigerant oil from the crankcase.

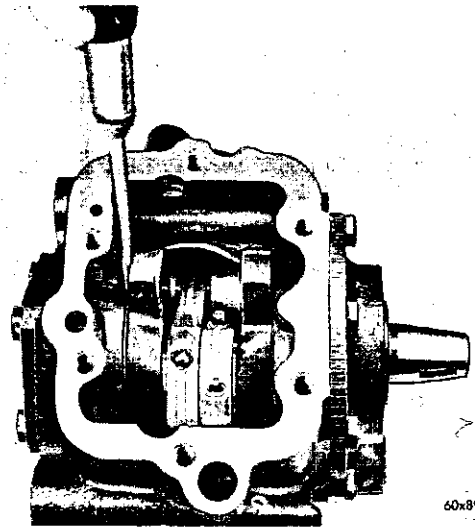

60x893A

60 x 893A

**Fig. 50—Measuring the Crankshaft Axial Movement**

- (1) Remove the oil pump cover plate and the oil seal.
- (2) Remove the drive shaft and the rotors.

**b. Installation**

- (1) Install the oil pump drive shaft by rotating the shaft until the tang end engages in the crankshaft slot.
- (2) Install the inner rotor on the drive shaft, engaging the drive.
- (3) Install the outer rotor, and rotate it until it will slide forward over the inner rotor cams. Turn the compressor crankshaft with the oil pump in this position to determine that rotors do not bind.
- (4) Install the oil pump cover plate and the oil seal.
- (5) Tighten the bolts 10 to 13 foot-pounds torque.

## EXPANSION VALVE, HEATER CORE, EVAPORATOR, BLOWER REMOVAL AND INSTALLATION

**EXPANSION VALVE**

The expansion valve is a factory-calibrated trouble free unit. It should not be removed or replaced unless a complete test has proved it to be faulty. It is recommended that Test 8, "The Expansion Valve Test", be performed before replacing the expansion valve.

**a. Removal**

The system must be completely discharged before opening any of the refrigerant lines.

- (1) Remove the equalizer line from the evaporator suction line fitting.
- (2) Disconnect the valve from the  $\frac{3}{8}$  inch inlet line and from the  $\frac{1}{2}$  inch outlet line. Use two flare

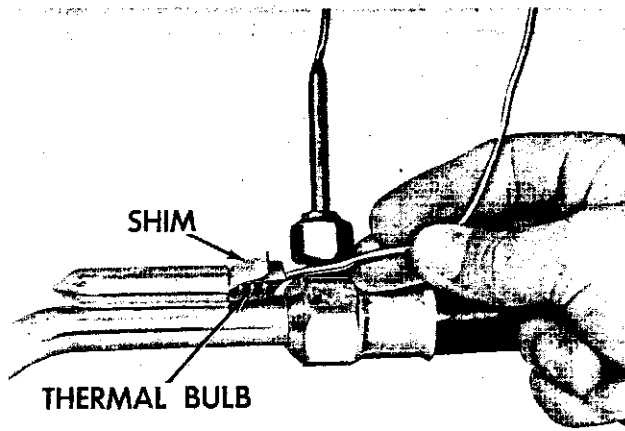

60x897

Fig. 51—Thermal Bulb Installed

wrenches to loosen each of these connections.

(3) Remove the grommet retainer and the rubber grommet from the evaporator engine-side housing. Carefully pull the thermal bulb (Fig. 51) and the thermal bulb wedging shims from the well located inside the evaporator housing.

#### b. Installation

Clean the thermal bulb well, wedging shims and thermal bulb before installing the expansion valve. The valve will not function properly unless there is a good thermal contact between the bulb and its well.

Clean the parts and a tight fit of the bulb in the well will insure a good thermal contact.

(1) Install the thermal bulb in its well, using brass wedging strips to insure a tight mechanical fit.

(2) Lubricate all expansion valve and line fittings with clean refrigerant oil. Install the expansion valve, using two flare wrenches to prevent rotation and twisting of the lines.

(3) Install the rubber grommet in the housing, and install the grommet retainer.

(4) Connect the equalizer tube to the fitting on the evaporator suction line.

(5) Using two flare wrenches, inspect all connections for tightness.

After the expansion valve is installed, it must be completely tested. Then the system must be tested for leaks and recharged.

## HEATER CORE

The heater core is located behind a **separate cover** attached to the evaporator engine-side housing. The core is held in position in its cover by two plastic rivets. The heater core and cover are removed and installed as an assembly. (Refer to Fig. 52.)

#### a. Removal

(1) Drain the cooling system and remove the heater hoses from the core.

(2) Disconnect the by-pass door vacuum actuator rod from the actuator linkage on the engine side housing. Disconnect the vacuum lines from the actuator.

(3) Remove the heater core and cover attaching the screws, and lift the entire assembly from the evaporator engine-side housing.

(4) Remove the cover-to-evaporator-housing gasket to expose the two plastic rivets. These are expandable-type rivets. Pull the expanding pin from each of the rivets so the core can be separated from the cover without damaging the rivets.

#### b. Installation

(1) Position the heater core in its cover and install the two plastic rivets to maintain alignment of these two parts.

(2) Install the rivet expanding pins in the rivets to hold the core and cover assembly together.

(3) Carefully position the gasket between the cover and the engine-side evaporator housing so it will seal both the core-to-cover flange and the cover-to-evaporator-housing joint. Cement the gasket in place to facilitate installation.

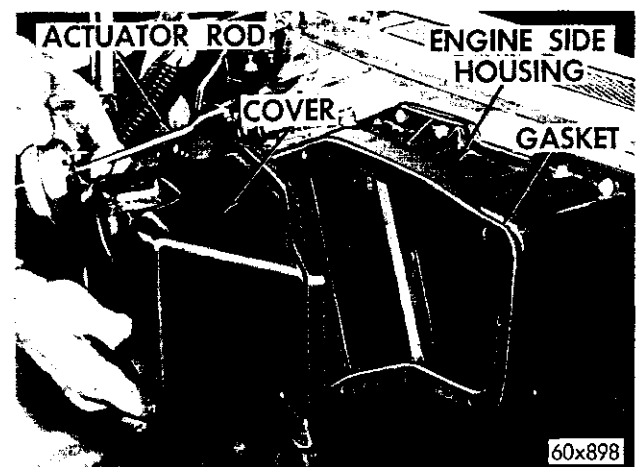

60x898

Fig. 52—Removing the Heater Core

(4) Install and tighten the heater core and cover attaching screws. Be careful to maintain the gasket alignment to insure an air-tight seal at this point.

(5) Connect the by-pass door actuator rod and vacuum lines.

(6) Connect the heater hoses, and refill the cooling system. For summer operation as well as winter operation, be sure the system is protected with the proper type and amount of antifreeze.

### EVAPORATOR ASSEMBLY

The evaporator assembly includes the evaporator core, the cast evaporator housing with fresh-air and recirculating doors, and the evaporator engine-side housing with the heater by-pass door. These sub-assemblies are built up before installation on the car to form a complete unitized evaporator assembly. The unitized evaporator assembly must be removed and installed as a complete assembly. (Refer to Fig. 53.)

#### a. Removal

(1) Remove the heater core and cover assembly from the evaporator engine-side housing. Remove the temperature control valve capillary from its well in the engine-side housing.

(2) Discharge the refrigerant from the system, and disconnect the expansion valve and the suction line. Cap all refrigerant lines to prevent entrance of dirt and moisture.



Fig. 53—Evaporator Installation

(3) Disconnect the recirculating door actuator rod from the recirculating door linkage. This actuator is located on the distribution duct in the passenger compartment. Position the recirculating door linkage so the **fresh-air door** is fully closed.

(4) Remove all 15 evaporator assembly attaching screws. These screws, particularly the ones located along the lower edge of the housing, are difficult to reach. They must all be removed before attempting to pull the evaporator assembly out of the dash panel. A  $\frac{3}{8}$ " drive flexible extension (Tool C-3622) and palm grip ratchet (Tool C-3616) will facilitate removal of the evaporator housing attaching screws. The evaporator assembly can now be pulled from the dash panel. Make sure that the fresh-air door remains closed as the assembly is removed.

It will not be necessary to separate the evaporator housing from the evaporator engine-side housing unless the evaporator core is to be repaired. To separate these two housings, drill out the tubular rivets. After installation of a new or repaired core, install new gaskets and cement them in place to insure an air-tight seal between the two housings. Reassemble the core in the evaporator housing and then assemble the evaporator housing to the engine-side housing, using tubular rivets.

#### b. Installation

Before installing the evaporator assembly, inspect the evaporator drains. Make sure they are secure and functioning properly. There is one tubular-type drain valve in the engine-side housing. If this valve sticks in the closed position, condensed moisture will collect in the evaporator. If the valve sticks in the open position, it will allow hot air to leak into the air distribution system. There are four flapper-type valves in the cast evaporator housing. It is recommended that a small piece of tape be used at the rear edge of each of these valves to hold it in place during installation of the evaporator assembly. Also, make sure there is an air-tight seal between the engine-side housing and the cast evaporator housing.

(1) Close the fresh-air door and install the evaporator assembly as shown in Figure 53. Make sure the rear edge of the rain shield is folded upward.

(2) Install all evaporator assembly attaching screws, and tighten lightly. After all screws are installed, tighten alternately until all are tight. Alternate tightening of the screws will prevent distortion or damage to the assembly.

(3) Install the heater core and cover. Install the temperature control valve sensing bulb in the engine-side housing. Connect the heater hoses.

(4) Reconnect the by-pass door and recirculating door vacuum actuators.

After the evaporator assembly is installed in the vehicle, it will be necessary to connect the expansion valve, sweep the system, test for leaks, and charge the system with the proper amount of refrigerant. It is recommended that the operation of all controls be tested and an over-all performance test be made after repair or replacement of the evaporator assembly.

### BLOWER AND DISTRIBUTION DUCT

#### a. Removal

- (1) Disconnect the battery ground cable.
- (2) Disconnect the heater ground wire at the windshield wiper motor mounting bracket and disconnect the blower and clutch circuit wires from the harness connectors.
- (3) Disconnect the vacuum hoses and the actuator rods from each vacuum unit. Remove the hoses from their attaching clips.
- (4) Disconnect the distribution duct damper control cable.
- (5) Remove the temperature control valve capillary from the engine-side housing.
- (6) Remove the three screws attaching the distribution duct to the dash panel (one is located to the left of the recirculating door and to the right of brake pedal bracket; one below the floor outlet at passenger side, and one screw is located at the windshield wiper motor right link pivot).

**NOTE:** To facilitate the removal, disconnect the windshield wiper right link at the pivot to expose the housing screw.

(7) Remove the housing and the blower by pulling down and out of driver's compartment. Remove the blower, mounting plate and motor. (See Fig. 54).

#### b. Installation

**NOTE:** If the blower is removed from the mounting plate, be sure the mounting grommets are installed at the attaching bolts.

- (1) Install the blower motor and mounting plate to the distribution duct. Be sure the blower wheel is free and does not rub.
- (2) Position the housing on the dash panel, making sure the large mounting-plate-to-dash-panel gasket is properly positioned to insure a good seal. Install the three attaching screws.

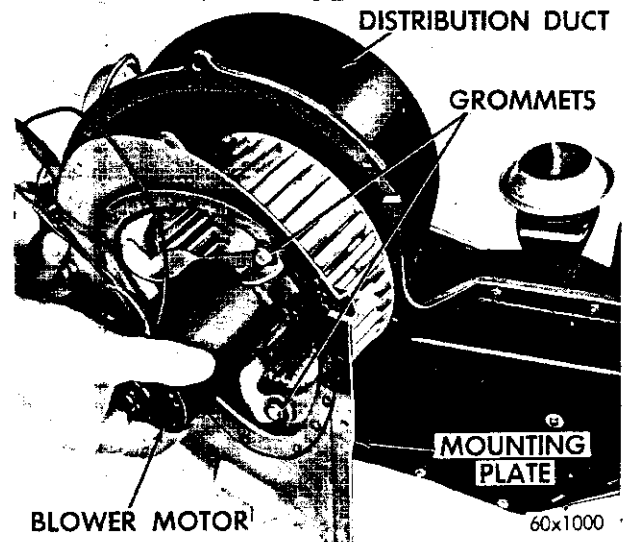

Fig. 54—Removing the Blower

#### CAUTION

There is a spacer at each attaching screw. Be sure these spacers are installed between the distribution duct and the dash panel when installing the housing; otherwise, the housing could be damaged when tightening the screws.

- (3) Reposition the temperature control valve capillary in the engine-side housing.
- (4) Connect the vacuum actuator hoses and rods, and install all attaching clips.
- (5) Connect and adjust the distribution duct damper control cable.
- (6) Connect the blower and clutch circuit wires. Install the ground wire at the windshield wiper motor bracket.
- (7) Attach the windshield wiper motor pivot link (if disconnected). Connect the battery ground cable.
- (8) Test the operation of all controls and actuators.

### REFRIGERANT SERVICE

Use only Refrigerant 12 in the air-conditioning system. Refrigerant 12 is available in bulk tanks or in sealed 15 ounce cans. The use of canned refrigerant is preferred by most technicians because it provides a very quick and simple means of adding refrigerant or charging the system completely.

All 1962 models equipped with the front-end units only require  $2\frac{5}{8}$  to  $2\frac{7}{8}$  pounds of refrigerant. Three 15-ounce cans of Refrigerant 12 provide a complete



charge without the necessity of weighing the refrigerant as it is dispensed. All 1962 models equipped with dual installations require  $3\frac{5}{8}$  to  $3\frac{7}{8}$  pounds of refrigerant. Four 15-ounce cans of Refrigerant 12 provide a complete recharge for these dual installa-

tions.

If the bulk tank method of charging is used, an accurate scale must be used to insure charging with the proper amount of refrigerant.

## COMPLETE SYSTEM DISCHARGE AND RECHARGE

Before the system can be opened for replacement of lines or components, the system must be completely discharged. It is also necessary to discharge the system before performing the compressor capacity test and the expansion valve test. Whenever the system has been opened, it must be swept with a partial charge, and the entire system tested for leaks. The drier should be replaced and the system evacuated using a vacuum pump to remove all air and moisture. The system should then be charged with the proper amount of refrigerant. Detailed instructions for performing these operations follow.

### DISCHARGE THE SYSTEM

(1) Be sure the valves of the gauge manifold set are closed before attaching the gauge set manifold (suction test hose to the suction service port and discharge test hose to the discharge service port). Attach the long test hose to the center connection of the gauge set manifold. Lead the other end of this hose into an exhaust ventilation system outlet or to the outside of the building.

(2) Open the gauge set manifold needle valve and close both of the gauge set manifold gauge valves.

(3) Start the engine and adjust speed to 1250 rpm.

(4) Pull the blower switch to "HIGH" position, move the temperature control to "OFF" and push the "FRESH COOL" button.

(5) Allow the system to operate at full capacity for at least 15 minutes. This will cause most of the compressor oil in the system to return to the compressor crankcase.

(6) Open the discharge (right-hand) gauge valve a small amount. This will allow the refrigerant vapor to discharge slowly.

### CAUTION

Do not allow the system to discharge rapidly since this would sweep some of the refrigerant oil out of the compressor.

(7) Allow the system to discharge until the dis-

charge pressure gauge registers zero. Open the left-hand valve to release any vapor trapped at the suction side of the system.

### SWEEP-TEST CHARGE

The purpose of the sweep-test charge is to pressurize the system so that a leak test can be made. The sweep-test charge also serves the purpose of drying the system or sweeping out trapped moisture. Repairs and component replacement must be completed before charging with the sweep-test charge.

(1) Close both gauge set manifold valves and open the gauge set manifold needle valve.

(2) Attach the free end of the long hose used for discharging to the refrigerant dispensing manifold.

(3) Attach a single can of Refrigerant 12 to the dispensing manifold. Place refrigerant in 125 degree water. For detailed instructions on attaching refrigerant can for charging, see "Charging the System".

(4) Operate the engine at 1250 rpm, car windows open, "FRESH COOL" button pushed in and the blower on high. If working on dual installations, operate both blowers on high speed.

(5) Slowly open the left-hand gauge set manifold valve to meter the refrigerant into the system. When the full can of refrigerant has been metered into the system, close the gauge set manifold valves and the refrigerant manifold valve.

If the system has been opened for repair or replacement, a complete leak test must be made to make sure the system is sealed. Also, if the system has accidentally lost its charge it will be necessary to perform a leak test while the sweep-test charge is in the system. Stop the engine and disconnect the test hoses and adapters from the compressor service ports.

### TESTING THE SYSTEM FOR LEAKS

The Leak Detector Torch (Tool C-3569) is a propane

gas-burning torch used to locate a leak in any part of the refrigeration system. Refrigerant gas drawn into the sampling or "Sniffer" tube will cause the flame to change color in proportion to the size of the leak. A very small leak will produce a flame color varying from yellowish-green to bright green. A large leak will produce a brilliant blue flame.

(1) Open the torch valve until you hear a faint hiss of escaping gas. Light the test torch and adjust the valve until the flame is very small. A small flame will detect large as well as small leaks, whereas, a large flame will detect only large leaks. As soon as the reaction plate seen through the window in the burner shield becomes red hot, the tester is ready for use.

(2) Examine all the tube connectors and other possible leak points by moving the end of the sampling hose from point to point. Since Refrigerant 12 is heavier than air, it is good practice to place the open

end of the sampling hose directly below the point being tested. Be careful not to pinch the sampling tube since this will shut off the air supply to the flame and cause a color change.

(3) Watch for a change in the color of the flame. Small leaks will produce a green and large leaks a bright blue color. If leaks are observed at the tube fittings, tighten the connection, using the proper flare wrenches, and retest.

#### TEST PRECAUTIONS

Do not use the lighted detector in any place where explosive gases, dust, or vapors are present.

Do not breathe the fumes that are produced by the burning of refrigerant gas. Large concentrations of refrigerant in the presence of a live flame become dangerously toxic. Observe the flame through the window of the burner shield, not through the top of the shield.

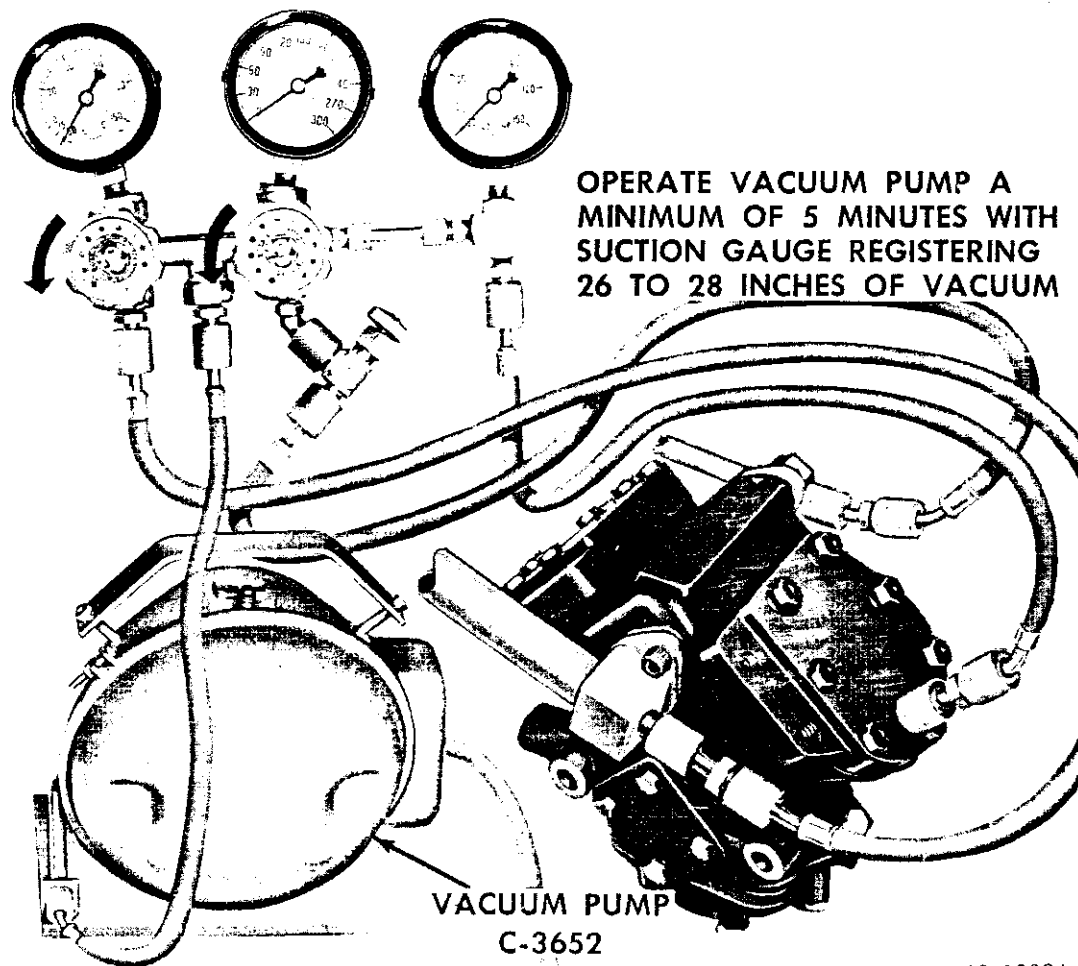

60x1C02A

Fig. 55—Evacuating the System

If the flame remains bright yellow when the tester is removed from a possible leak point, insufficient air is being drawn in through the sampling tube, or the reaction plate is dirty.

#### Remove Sweep-Test Charge

If the system is free of leaks, or after correcting a leak, if no air conditioning components have been removed, add the necessary refrigerant as described under "Correcting the Low Refrigerant Level". If any parts of the refrigerant system were disconnected remove the sweep test charge. Close the refrigerant manifold valve so that any refrigerant remaining in the container is sealed. Remove the long test hose from the refrigerant manifold. Insert the free end of this test hose into an exhaust system outlet. Open the right-hand gauge set manifold valve a fraction of a turn to let the sweep-test charge escape slowly. Allow the system to discharge until the discharge pressure gauge registers zero. Open the left-hand gauge valve to allow any refrigerant trapped in the suction side of the system to escape.

#### REPLACE THE RECEIVER—DRIER—STRAINER

The system must be discharged and swept with a test charge before replacing the receiver-drier-strainer. To remove the receiver-drier-strainer, simply unscrew it from the combination dry-eye sight glass. When installing a new receiver-drier-strainer, use a new gasket. Tighten the new unit to 12 foot pounds torque. Do not overtighten since this might damage the gasket.

#### CAUTION

Replacement of the receiver-drier-strainer unit must be sealed while in storage. The drier used in these units is so hungry for moisture that they can saturate quickly upon exposure to the atmosphere. When installing a drier, have all tools and supplies ready for quick reassembly to avoid keeping the system open any longer than necessary.

#### EVACUATE THE SYSTEM

Whenever the system has been opened to atmosphere, it is absolutely essential that the system be swept with refrigerant and evacuated or "vacuumed" to remove all the air and the moisture. If any appreciable amount of air remains in the system when it is charged, the trapped air will concentrate near the top of the condenser and cause abnormally high discharge pressures. Air in the system will reduce the condenser's ability to condense the refrigerant

gas and supply adequate liquid refrigerant to the evaporator.

#### To evacuate the system:

(1) Connect the gauge set manifold to the compressor and the long test hose from the gauge set manifold center connection to the vacuum pump (Tool C-3652) as shown in Figure 55.

(2) Open both gauge set manifold valves and the needle valve.

(3) Start the vacuum pump and operate until the evaporator suction gauge registers at least 26 inches of vacuum. If the system is tight and the pump in good condition, the vacuum will go as low as 28 inches.

(4) Allow the vacuum pump to operate with suction gauge registering 26 to 28 inches of vacuum for a minimum of five minutes.

(5) Close both gauge set manifold valves, turn off the vacuum pump and remove the test hose from the vacuum pump. Leave the gauge set manifold connected to the compressor. Charge the system with the proper amount of Refrigerant 12.

**NOTE:** Failure to pull at least 26 inches of vacuum indicates a leak in the refrigeration system or a defective vacuum pump. Locate and correct the trouble before recharging the system.

#### CHARGING THE SYSTEM (Fig. 16)

All models equipped with front air-conditioning units only require three cans or 45 ounces of Refrigerant 12. All dual type installations require four cans or 60 ounces of Refrigerant 12. The special refrigerant dispensing manifold permits charging three full cans of refrigerant at one time. On dual installations a single can must be added after the three cans have been charged into the system.

**NOTE:** Keep the refrigerant manifold valves capped when not in use. Keep a supply of extra refrigerant-can-to-refrigerant-manifold gaskets on hand so that gaskets can be replaced periodically. This will insure a good seal without excessive tightening of the can or the manifold nuts.

(1) Attach the center hose from the gauge set manifold to the refrigerant dispensing manifold. Turn the refrigerant manifold valves completely counter-clockwise so that they are fully open. Remove the protective caps from the refrigerant manifold.

(2) Screw the refrigerant cans into the manifold.

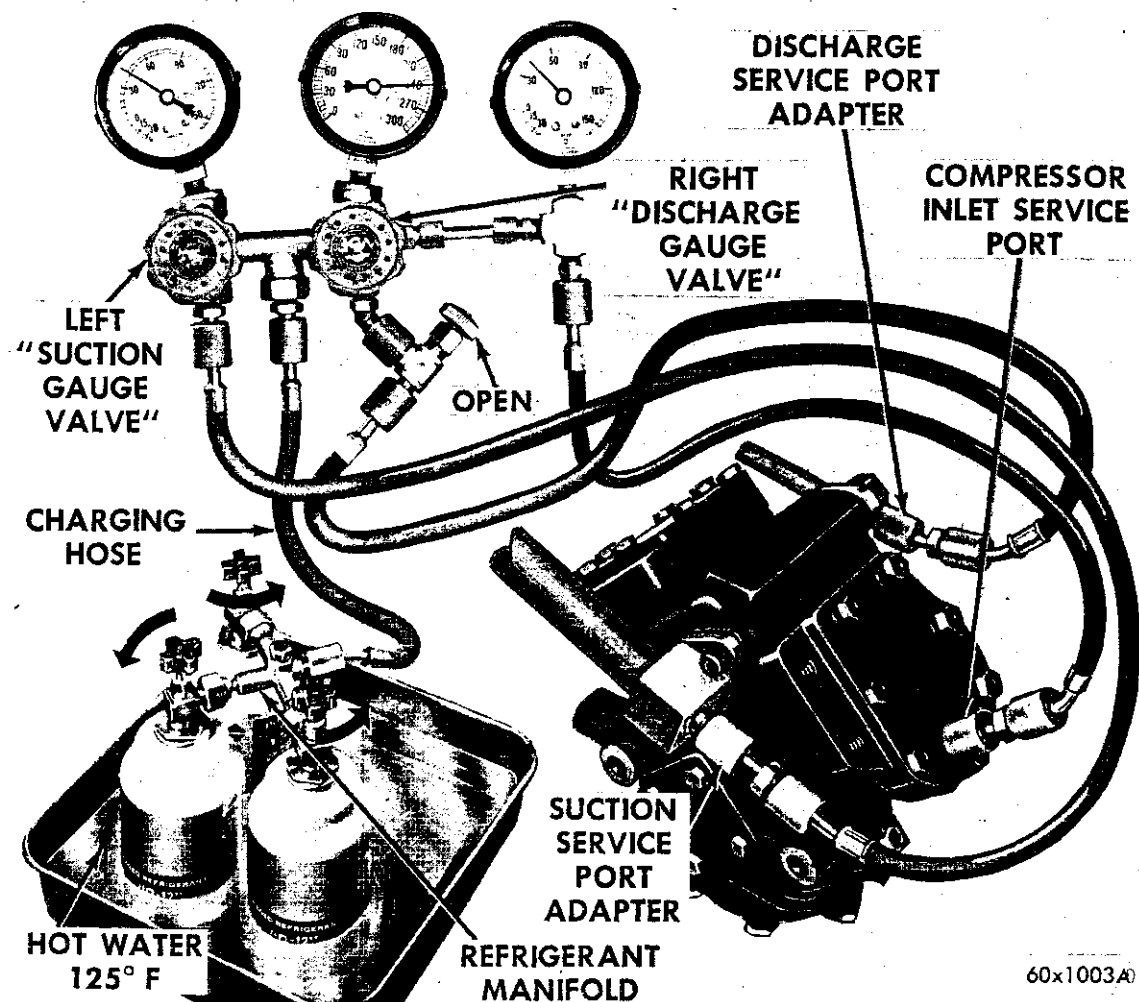

Fig. 56—Complete System Charging

Be sure the manifold-to-can gasket is in place and in good condition. Tighten the can and the manifold nuts 6 to 8 foot-pounds.

(3) Turn the three refrigerant manifold valves completely clockwise to puncture the cans and close the manifold valves.

(4) Turn the refrigerant manifold valves counter-clockwise to open them.

(5) Momentarily loosen the charging hose at the gauge set manifold to allow the refrigerant gas to purge air out of the charging hose.

(6) Place the three cans of refrigerant into a pan containing hot water at a temperature of 125 degrees F.

(7) Start the engine and adjust the speed to 1250 rpm.

(8) Charge the system through the suction side of the system by slowly opening the left-hand gauge set manifold valve. Adjust the valve as necessary so the charging pressure does not exceed 50 psi. Maintain the temperature of the water in the pan by adding warm water as necessary.

When all three cans of refrigerant are completely empty, close the gauge set manifold valves and the refrigerant manifold valves. If the system being worked on is a dual system, attach a single can and charge into the system using the above procedure.

60x1003A

## SERVICE DIAGNOSIS

## AIR CONDITIONING

No attempt should be made to use the diagnosis information as a method of trouble shooting or spot checking. When properly used (as an aid to complete test procedure), the diagnosis will be of considerable value to the service man.

Condition	Possible Cause	Correction										
<b>Blower Not Operating</b>	(a) Blown fuse, broken wire, faulty switch motor, loose or dirty connections.	(a) Test the electrical circuit with point to point voltmeter test repair or replacing the faulty parts.										
<b>Blower and Compressor Operating—No Cooling</b>	(a) Low refrigerant, moisture, frozen, stuck or faulty expansion valve, stuck or faulty E.P.R. valve. (b) Low compressor capacity. (c) Kinks in lines. (d) Faulty water valve or out of adjustment.	(a) Add refrigerant, test for leaks and repair, replace the strainer-drier, clean or replace expansion valve, replace E.P.R. valve. (b) Repair or replace the compressor. (c) Repair or replace the lines. (d) Adjust cable and/or replace the valve.										
<b>Blower Operating Partial Cooling</b>	(a) Moisture, low refrigerant, low compressor capacity. (b) Slipping clutch. (c) Water valve out of adjustment or faulty. (d) Obstruction of condenser.	(a) Replace strainer-drier, add refrigerant test for leaks and correct, repair or replace the compressor. (b) Repair or replace. (c) Adjust the cable or replace. (d) Clean the condenser, repair replace and no Bug Screens.										
<b>Low Suction and Low Discharge Pressure</b>	(a) Low refrigerant, moisture in system, expansion valve froze or stuck, thermal bulb lost charge, restriction in liquid line, bad compressor valves, too much oil.	(a) Add refrigerant, test for leaks and correct, replace strainer-drier, clean or replace expansion valve, repair or replace liquid line, repair or replace compressor, remove the excess oil.										
<b>High Discharge Pressure</b>	(a) Too much refrigerant. (b) Air in system. (c) Dirty condenser. (d) High ambient temperature.	(a) Purge the system for 10 seconds. (b) Purge the system for 10 seconds. (c) Clean the condenser, no bug screens. (d) NOTE: Discharge and Suction pressures will vary with the ambient temperature and the heat load applied to the evaporator. Normal Suction pressure will vary between 25 to 40 psi. Normal Discharge pressure at 1200 engine rpm as indicated below:										
		<table> <thead> <tr> <th>Ambient Temperature</th> <th>Discharge Pressure</th> </tr> </thead> <tbody> <tr> <td>60°F</td> <td>100-150 psi</td> </tr> <tr> <td>80°F</td> <td>140-190 psi</td> </tr> <tr> <td>100°F</td> <td>190-240 psi</td> </tr> <tr> <td>110°F</td> <td>130-280 psi</td> </tr> </tbody> </table>	Ambient Temperature	Discharge Pressure	60°F	100-150 psi	80°F	140-190 psi	100°F	190-240 psi	110°F	130-280 psi
Ambient Temperature	Discharge Pressure											
60°F	100-150 psi											
80°F	140-190 psi											
100°F	190-240 psi											
110°F	130-280 psi											

---

**SERVICE DIAGNOSIS—CONT'D**

---

<b>Condition</b>	<b>Possible Cause</b>	<b>Correction</b>
<b>High Suction Pressure</b>	(a) Moisture in system. (b) Expansion valve froze or stuck open. (c) Expansion valve equalizer tube plugged. (d) Bad compressor valves. (e) Not enough oil.	(a) Change the strainer-drier—recharge. (b) Change the strainer-drier—recharge, clean or replace expansion valve. (c) Clean or replace the expansion valve. (d) Replace the valve plates. (e) Add oil.

---