

GROUP 22 - WHEELS

PARTS INDICATED BY NAME ONLY - ORDER BY DESCRIPTION

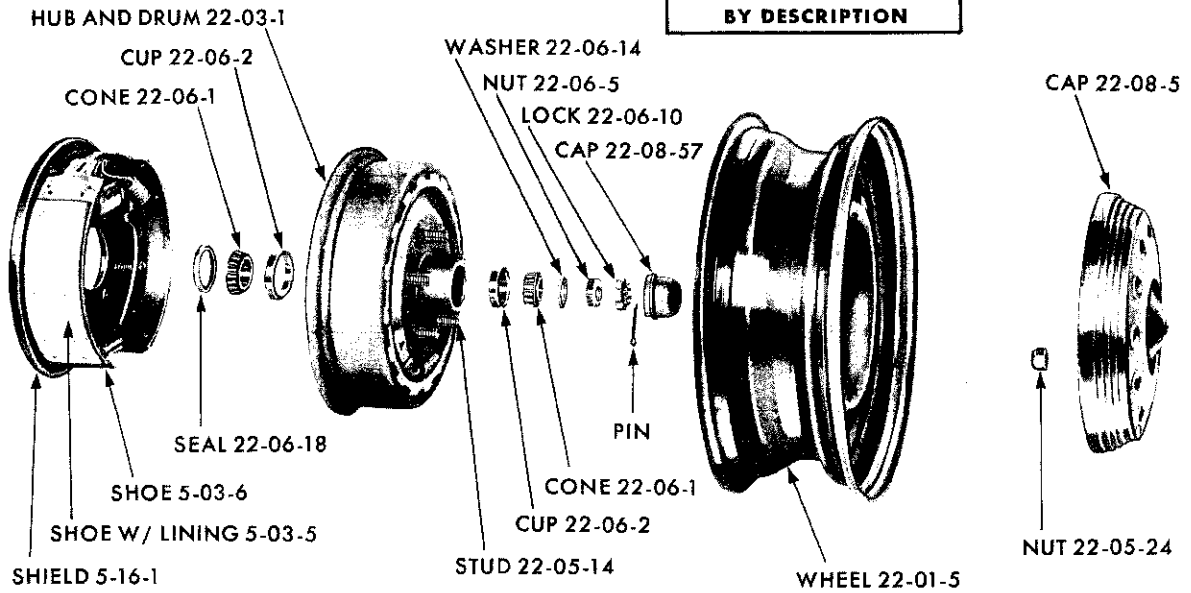

19x8785A

FRONT WHEEL - VALIANT SV1 AND LANCER SL1

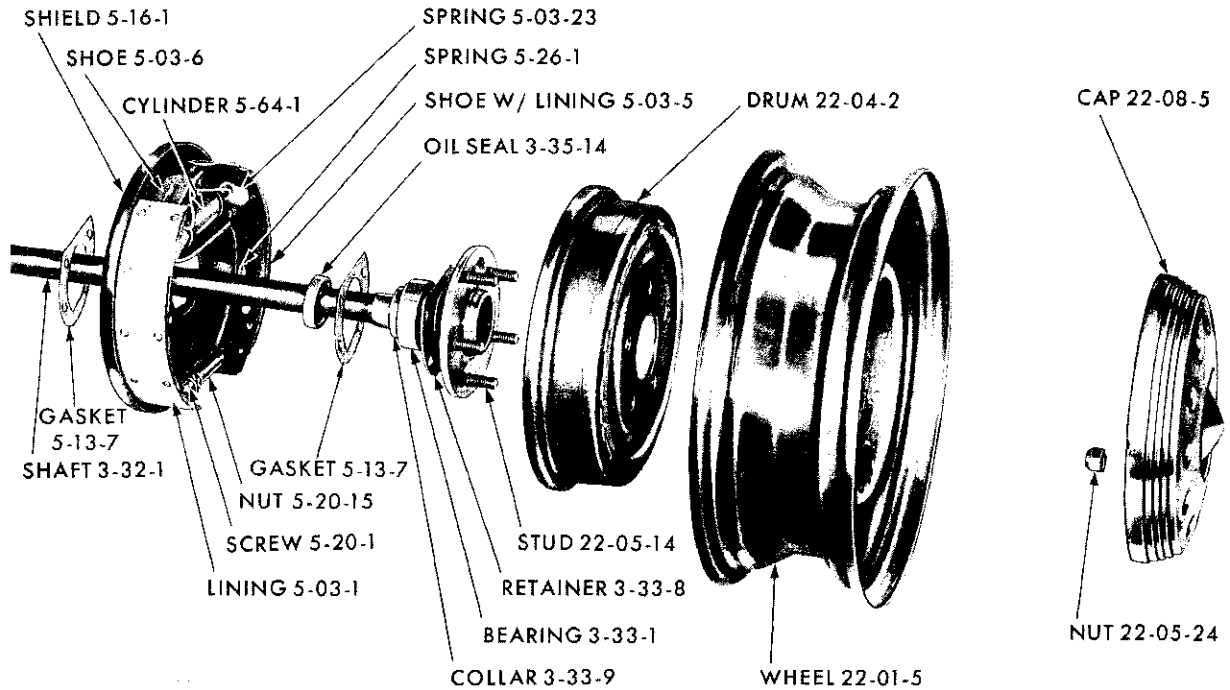

19x8787B

REAR WHEEL - VALIANT SV1 AND LANCER SL1

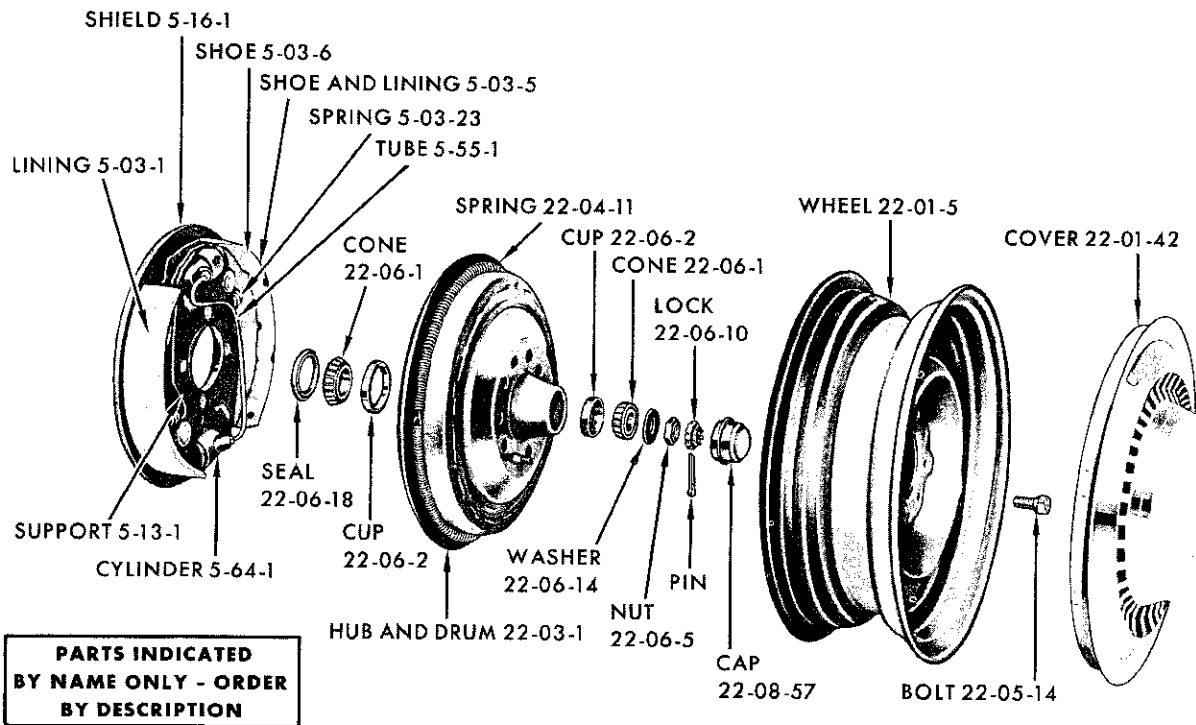

19x8998A

FRONT WHEEL - CHRYSLER SC1-2-3

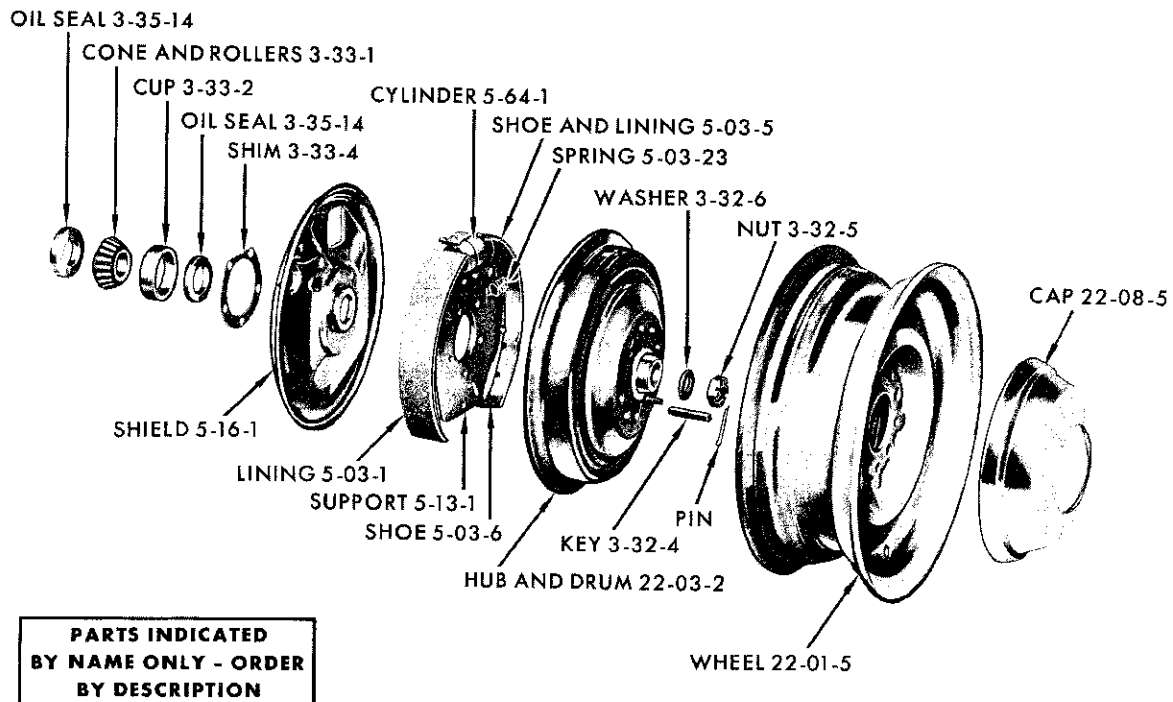

19x8999A

REAR WHEEL - CHRYSLER SC1

22-01-0 WHEELS

TIRE CHART

Wheel Size	Tire Size
13 x 4.50	6.50 x 13
14 x 5.00	6.50 x 14 - 7.00 x 14 - 7.50 x 14
14 x 5.50	7.00 x 14 - 7.50 x 14 - 8.00 x 14
14 x 6.00	8.00 x 14 - 8.50 x 14
14 x 6.50	9.00 x 14
15 x 5.50	6.70 x 15
15 x 6.00	7.60 x 15
15 x 6.00	7.60 x 15 - 8.00 x 15 - 8.20 x 15

CODE	PART NAME AND DESCRIPTION	CYL.	PER CAR	VALIANT LANCER	PLYMOUTH DODGE	CHRYSLER IMPERIAL
22-01-5	WHEEL, 13 x 4.50 . . . . .		5	2073 342		
	14 x 5.00 except Sub., SP1, SP2, SD1, SD2 . . .		5	-----	2298 522	
	14 x 5.50, SP1, SP2, SD1, SD2 . . . . .		5	-----	2298 523	
	14 x 5.50, SD3, SC1 . . . . .	8	5	-----	2084 628	2084 628
	15 x 5.50 . . . . .		5	-----	1856 808	
	14 x 6.00, SD3, SC1, SC2, SC3 except Sub. . . .	8	5	-----	2275 898	2275 898
	14 x 6.50, SC3 Sub. . . . .		5	-----	-----	2122 468
	15 x 6.00, SC1, SC2, SC3 . . . . .	8	5	-----	-----	2200 928
	15 x 6.00, SY1 . . . . .		5	-----	-----	*1948 155
	15 x 6.50, SC3, Ambulance and Limousine . . .	8	5	-----	-----	2260 158
22-01-42	COVER, Wheel, SV1-L, SV1-H . . . . .	6	4	2266 135		
	SV1-P . . . . .	6	4	2266 836		
	SL1-L, SL1-H . . . . .	6	4	2266 143		
	SL1-P . . . . .	6	4	2266 144		
	SP1, SP2-L, SP2-H . . . . .		4	-----	2207 626	
	SP2-P, w/9 Ripples, AFTER Cars . . . . .	8	4	-----	2265 638	
	SP2-P, Plain, UP TO Cars . . . . .	8	4	-----	2401 958	
	SD1, SD2-L, SD2-H . . . . .		4	-----	2266 136	
	SD2-P, SD3 . . . . .	8	4	-----	2266 834	
	SC1, SC3, Police and Ambulance, 15" Wheel . .	8	4	-----	-----	2260 160
	SC1, SC2, SC3, 14" Wheel . . . . .		4	-----	-----	*2266 137
	SC2, 15" Wheel "300" . . . . .		4	-----	-----	2265 535
	SY1 . . . . .		4	-----	-----	2266 139
22-01-43	MEDALLION, Wheel Cover, SC2 "300" . . . . .		4	-----	-----	1828 420
	SPINNER, Cover Dome, SD2-P, SD3 . . . . .		4	-----	2266 831	
22-01-49	RETAINER, Wheel Cover, SC2 "300" . . . . .		4	-----	-----	1829 625
22-01-51	DOME, Wheel Cover, SD2-P, SD3, SC2 . . . . .		4	-----	2266 832	1829 624
	SY1 . . . . .		4	-----	-----	2265 531
<b>22-03-0 HUB AND BRAKE DRUM</b>						
22-03-1	HUB and BRAKE DRUM, Front, Cal. Blt., Right .	6	1	*2072 794		
	Left . . . . .	6	1	2072 795		
	Detroit Blt., Right . . . . .	6	1	*2260 534		
	Left . . . . .	6	1	2260 535		
	Except Detroit and Cal. Blt., Right . . . . .	6	1	*2267 080		
	Left . . . . .	6	1	*2267 081		
	10" x 2 1/2" Cal. Blt., Right, SP1, SP2, SD1, SD2		1	-----	2266 384	
	Left . . . . .		1	-----	2266 385	
	10" x 2 1/2" Detroit Dodge Blt., Right, SD1, SD2		1	-----	2266 386	
	Left . . . . .		1	-----	2266 387	

★ Indicates use as required.

☐ Indicates parts not listed in any previous parts book.

\* Indicates change or addition.

Numerals in parentheses ( ) refer to notes.

Prices and specifications subject to change without notice.

March 8, 1963 Supersedes May 1, 1962.

# 1962 PASSENGER CAR PARTS CATALOG

WHEELS

CODE	PART NAME AND DESCRIPTION	CYL.	PER CAR	VALIANT LANCER	PLYMOUTH DODGE	CHRYSLER IMPERIAL
<b>22-03-0 HUB AND BRAKE DRUM - Cont'd</b>						
22-03-1	HUB and BRAKE DRUM - Cont'd					
	10" x 2 1/2" except Cal. and Detroit Dodge Blt., Right, SP1, SP2, SD1, SD2		1	----	2266 382	
	Left		1	----	2266 383	
	11" x 3", Right, SP1, SP2, SD1, SD2		1	----	2266 390	
	Left		1	----	2266 391	
	11" x 2 1/2" Right, SD3, SC1, except Sub.		1	----	2401 022	2401 022
	Left		1	----	2401 023	2401 023
	12" x 2 1/2", SD3, SC1, SC2, SC3, Right		1	----	2275 434	2275 434
	Left		1	----	2275 433	2275 433
	Right, SY1		1	----	----	2265 218
	Left, SY1		1	----	----	2265 219
22-03-2	HUB and BRAKE DRUM, Rear, 10" x 2 1/2" Brakes, Right, Steel Encased, SP1, SP2, SD1, SD2		1	----	2260 904	
	Left, Steel Encased		1	----	2260 905	
	10 x 2 1/2" Brakes, Right, Cast Iron, SP1, SP2, SD1, SD2		1	----	2265 550	
	Left, Cast Iron		1	----	2265 551	
	11 x 2 1/2" Brakes, Right, SP1, SP2, SD1, SD2		1	----	2265 354	
	Left		1	----	2265 355	
	11 x 2 1/2" Brakes, Right, SD3, SC1, except Sub.		1	----	2401 000	2401 000
	Left		1	----	2401 001	2401 001
	12 x 2 1/2" Brakes, Right, SD3, SC1, SC2, SC3		1	----	1732 512	1732 512
	Left		1	----	1732 513	1732 513
	12" x 2 1/2" Brakes, Right, SY1		1	----	----	1732 296
	Left, SY1		1	----	----	1732 297
<b>22-04-0 BRAKE DRUM</b>						
22-04-2	DRUM, Rear, Steel Encased	6	2	*2267 083		
	Cast-Iron	6	2	2260 538		
22-04-4	SEAL, Front Wheel Brake Drum, SC1	8	2	----	----	2265 373
22-04-11	SPRING, Front Wheel Brake Drum Dampener	6	2	*2266 298		
	w/379 Coils, 35 3/16" SD3		★	----	1142 258	1142 258
	w/344 Coils 32", SD3		★	----	1142 259	1142 259
	10" Brakes		★	----	1142 316	
22-04-14	RETAINER, Drum to Axle Shaft	6	★	*2072 676		
<b>22-05-0 WHEEL HUB</b>						
22-05-14	STUD, Front, Right, Cal. Blt.	6	5	*2265 390		
	Left	6	5	2265 391		
	Front, Right, Detroit Blt.	6	5	2260 540		
	Left	6	5	2260 541		
	Front, Right, except Detroit and Cal. Blt.	6	5	2072 750		
	Left	6	5	2072 751		
	Rear, Right	6	5	*2070 158		
	Left	6	5	2070 159		
	10" x 2 1/2" Brake, Cal. Blt., Right	10		----	*2267 072	
	Left	10		----	2267 073	
	10" x 2 1/2" Brake, Detroit Dodge Blt., Right	10		----	1799 554	
	Left	10		----	1799 555	
	10" x 2 1/2" Brake, except Cal. and Detroit Dodge Blt., Right	10		----	1633 050	
	Left	10		----	1633 051	

★ Indicates use as required.

Numerals in parentheses ( ) refer to notes.

Printed in U.S.A.

⊠ Indicates parts not listed in any previous parts book.

Prices and specifications subject to change without notice.

March 8, 1963 Supersedes May 1, 1962.

\* Indicates change or addition.

CODE	PART NAME AND DESCRIPTION	C Y L.	PER CAR	VALIANT LANCER	PLYMOUTH DODGE	CHRYSLER IMPERIAL
<b>22-05-0 WHEEL HUB - Cont'd</b>						
22-05-14	STUD - Cont'd					
	12" Right, SD3, SC1, SC2, SC3		10	----	1633 050	1633 050
	Left		10	----	1633 051	1633 051
	11" Right, SD3, SC1, except Sub.		10	----	*2122 208	*2122 208
	Left		10	----	*2122 209	*2122 209
	Right, SY1		10	----	----	1633 052
	Left, SY1		10	----	----	1633 053
22-05-24	NUT, Wheel Mtg. Right	6	10	2072 728		
	Left	6	10	2072 729		
	Wheel Driving, Right, SC1, SC2, SC3		10	----	1139 316	1139 316
	Left, SC1, SC2, SC3		10	----	1139 317	1139 317
	Right, SY1	8	10	----	----	1315 697
	Left, SY1	8	10	----	----	1315 698
<b>22-06-0 FRONT WHEEL BEARING</b>						
22-06-1	CONE and ROLLER, Inner, SC1, SC2, SC3		2	2203 352	1619 701	1619 701
	Outer, SC1, SC2, SC3		2	2203 350	1619 703	1619 703
	Inner, SY1	8	2	----	----	1789 755
	Outer, SY1	8	2	----	----	1790 241
22-06-2	CUP, Inner, SC1, SC2, SC3		2	2203 353	1619 700	1619 700
	Outer, SC1, SC2, SC3		2	2203 351	1619 702	1619 702
	Inner, SY1		2	----	----	1789 754
	Outer, SY1		2	----	----	1790 244
22-06-5	NUT		2	2072 731	1732 300	1732 300
22-06-10	LOCK, Nut		2	1673 324	1673 324	1673 324
22-06-14	WASHER, Nut Thrust		2	2072 733	600 194	600 194
22-06-18	SEAL, Hub Dust, SP1, SP2, SD1, SD2		2	2072 707	2266 378	----
	SD3, SC1, SC2, SC3		2	----	*1613 409	*1613 409
	SY1	8	2	----	----	*1671 340
<b>22-08-0 HUB CAP</b>						
22-08-5	CAP, SV1		4	2073 361		
	SL1		4	2208 050		
	14" Wheel, SC1		4	----	2266 123	2266 123
	15" Wheel		4	----	1943 733	1943 733
22-08-17	CLIP, Spring, SC2		25	----	1316 017	1316 017
22-08-57	CAP, Grease, SC1, SC2, SC3		2	2072 718	1613 416	1613 416
	SY1		2	----	----	1671 341
<b>22-09-0 WHEEL BALANCE WEIGHT</b>						
22-09-1	WEIGHT, 1/2 oz.		★	----	1615 349	1615 349
	1 oz.		★	----	1615 350	1615 350
	1 1/2 oz.		★	----	1615 351	1615 351
	2 oz.		★	----	1615 352	1615 352
	2 1/2 oz.		★	----	1615 353	1615 353
	3 oz.		★	----	1615 354	1615 354
<b>22-20-0 SPARE WHEEL CARRIER</b>						
22-20-29	BRACKET, Mtg.	6	1	2083 190		
	Spare Wheel Anchor Bolt, except Sub., SP1, SP2, SD1, SD2		1	----	2254 611	
	SP1, SP2, SD1, SD2, Sub.		1	----	2254 646	
	Floor Pan Spare Wheel Anchor Bar, SP1, SP2, SD1, SD2, Sub. and Cv. Cp.		1	----	2254 646	

★ Indicates use as required.

Numerals in parentheses ( ) refer to notes.

Printed in U.S.A.

□ Indicates parts not listed in any previous parts book.

Prices and specifications subject to change without notice.

\* Indicates change or addition.

