

1962 PLYMOUTH

INTERIOR TRIM

HOW TO USE INTERIOR TRIM ILLUSTRATIONS

The illustrations in this section are actual and each body style showing the Interior Trim is included.

The letters shown on the illustration indicate the description of the part and the part type code when referred to the legend which appears preceding the listing of the parts. The letters are consistent throughout the illustrations as "A" is always a Door Trim Panel, Code 23-92-5.

The numbers on the illustration indicate the distribution of material and type of material used. The numbers may vary with each illustration. The legend appears on the illustration.

For complete information on "How to Order" Trim Parts, see Mopar Parts Price List.

P
L
Y
M
O
U
T
H

1962 PLYMOUTH - S SERIES

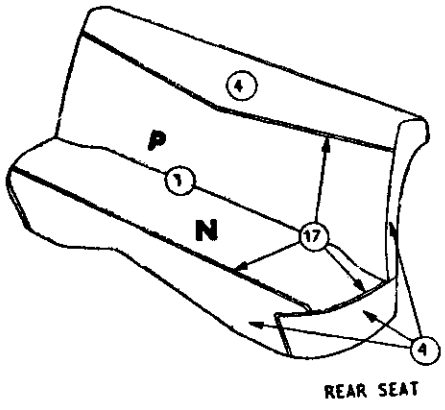
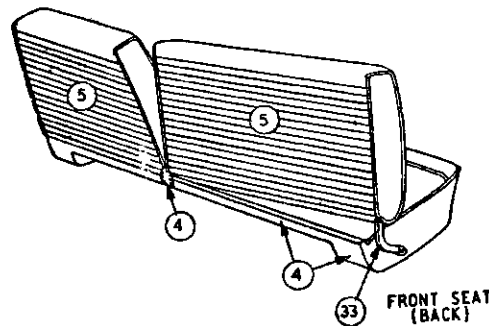
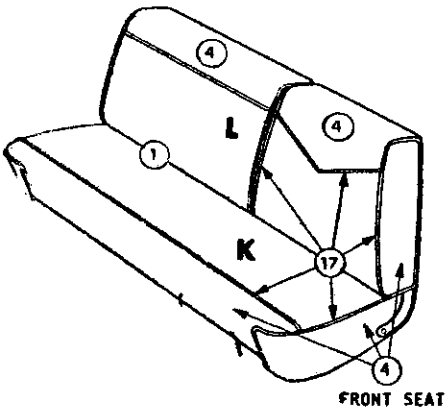
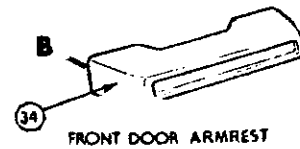
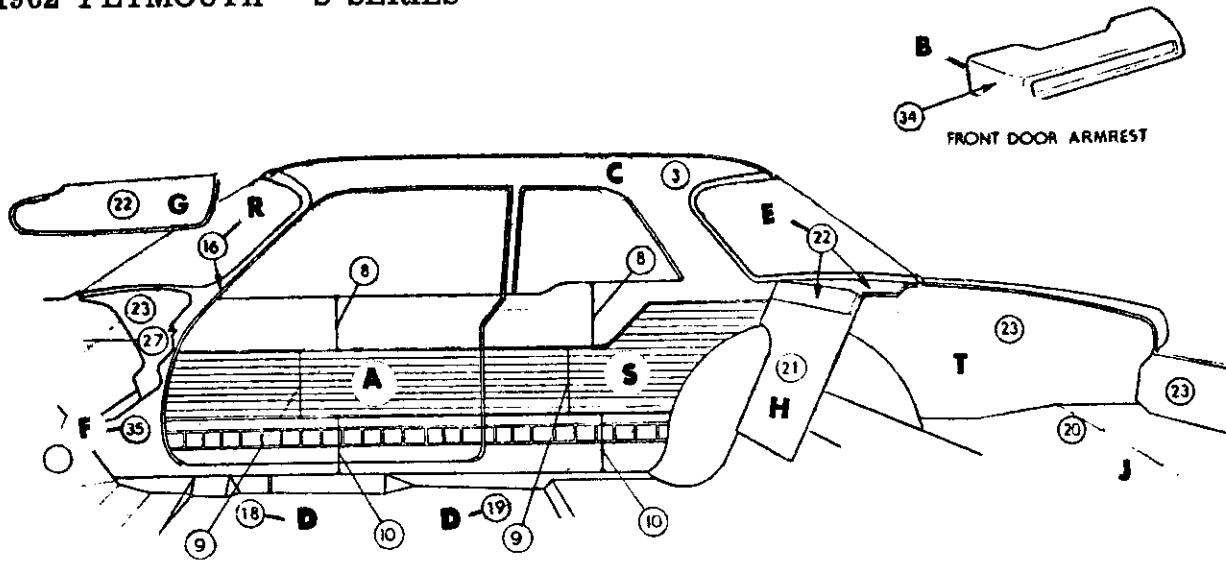

DISTRIBUTION OF MATERIAL

- 1 BODY CLOTH I
- 3 HEADLINING
- 4 IMITATION LEATHER 28-AM-22
- 5 IMITATION LEATHER 21-CZ-22
- 8 IMITATION LEATHER 19-DJ-22
- 9 IMITATION LEATHER .012-L-22
- 10 IMITATION LEATHER .012A-L-22
- 16 LACE
- 17 EXTRUDED VINYL
- 18 FLOOR COVERING-FRONT-RUBBER
- 19 FLOOR COVERING-REAR-RUBBER
- 20 FLOOR COVERING-LUGG. COMPT. RUBBER
- 21 CARDBOARD
- 22 EMBOSSED CARDBOARD
- 23 PAINT
- 27 MOULDED RESIN
- 33 PLASTIC
- 35 POLYETHYLENE

Distribution Drawing Legend Page Appears Following Illustration Section

Codes 101, 103, 104

SPL-211

1962 PLYMOUTH SP1-L, SP2-L 2 DOOR SEDAN
CLOTH AND IMITATION LEATHER COMBINATION

1962 PLYMOUTH - S SERIES

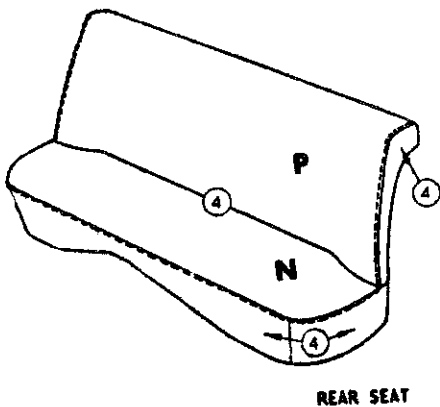
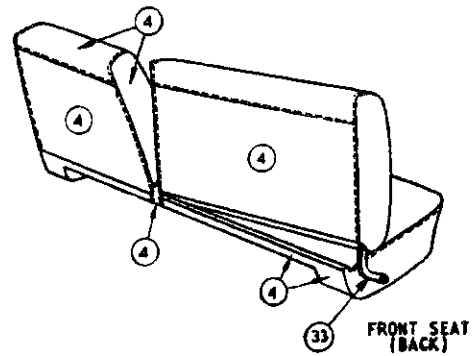
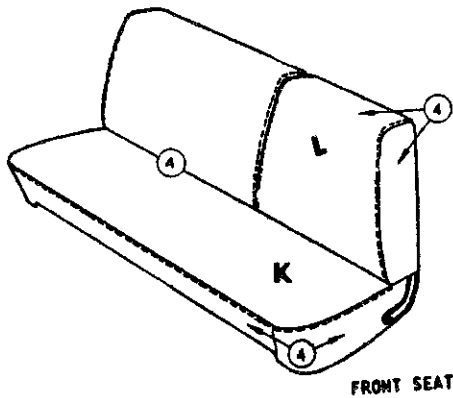
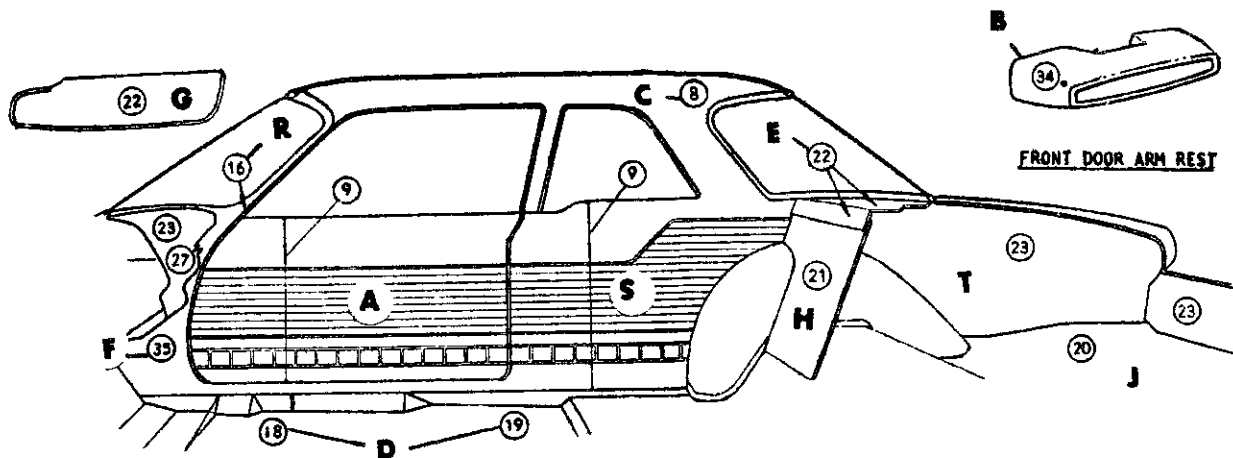

DISTRIBUTION OF MATERIAL

- 4 IMITATION LEATHER 37-CX-22
- 8 IMITATION LEATHER 18-T-16
- 9 IMITATION LEATHER 19-DJ-22
- 16 LACE
- 18 FLOOR COVERING-FRONT-RUBBER
- 19 FLOOR COVERING-REAR-RUBBER
- 20 FLOOR COVERING-LUGG. COMPT. RUBBER
- 21 CARDBOARD
- 22 EMBOSSED CARDBOARD
- 23 PAINT
- 27 MOULDED RESIN
- 33 PLASTIC
- 34 PLASTISOL
- 35 POLYETHLENE

Distribution Drawing Legend Page Appears Following Illustration Section

Code 294

SPL-214A

1962 PLYMOUTH SP1-L, SP2-L,
SP1-M, SP2-M CLUB SEDAN
IMITATION LEATHER

1962 PLYMOUTH - S SERIES

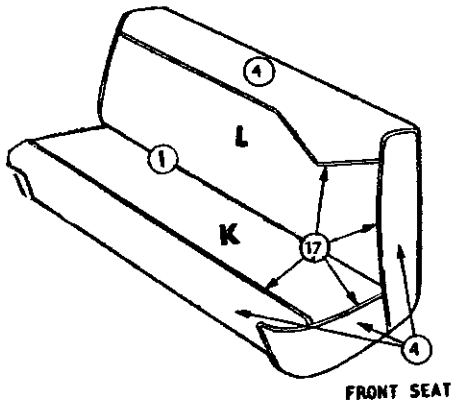
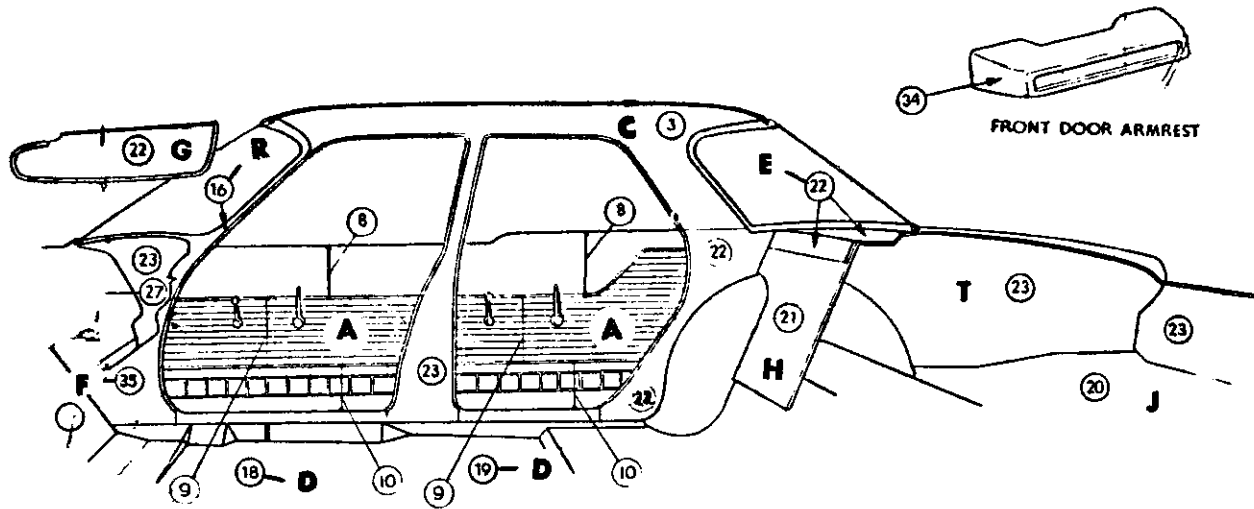

FRONT SEAT

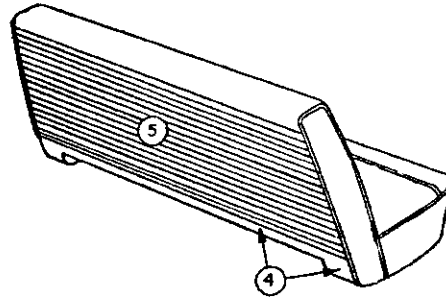

FRONT SEAT (BACK)

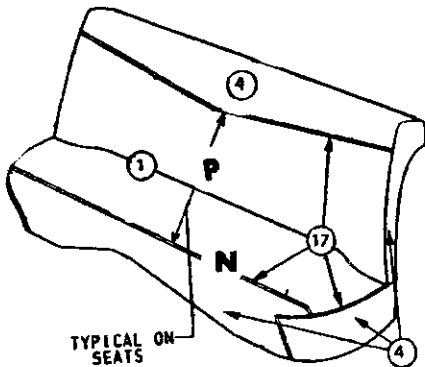

REAR SEAT

TYPICAL ON SEATS

DISTRIBUTION OF MATERIAL

- 1 BODY CLOTH
- 3 HEADLINING
- 4 IMITATION LEATHER 28-AM-22
- 5 IMITATION LEATHER 21-CZ-22
- 8 IMITATION LEATHER 19-DJ-22
- 9 IMITATION LEATHER .012-L-22
- 10 IMITATION LEATHER .012A-L-22
- 16 LACE
- 17 EXTRUDED VINYL
- 18 FLOOR COVERING-FRONT-RUBBER
- 19 FLOOR COVERING-REAR-RUBBER
- 20 FLOOR COVERING-LUGG. COMPT. RUBBER
- 21 CARDBOARD
- 22 EMBOSSED CARDBOARD
- 23 PAINT
- 34 PLASTISOL
- 35 POLYETHYLENE

Distribution Drawing Legend Page Appears Following Illustration Section

Codes 101, 103, 104

SPL-411

1962 PLYMOUTH SP1-L, SP2-L 4 DOOR SEDAN
CLOTH AND IMITATION LEATHER COMBINATION

1962 PLYMOUTH - S SERIES

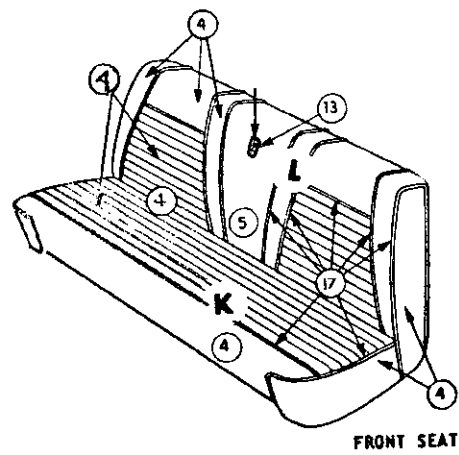
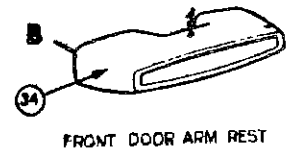
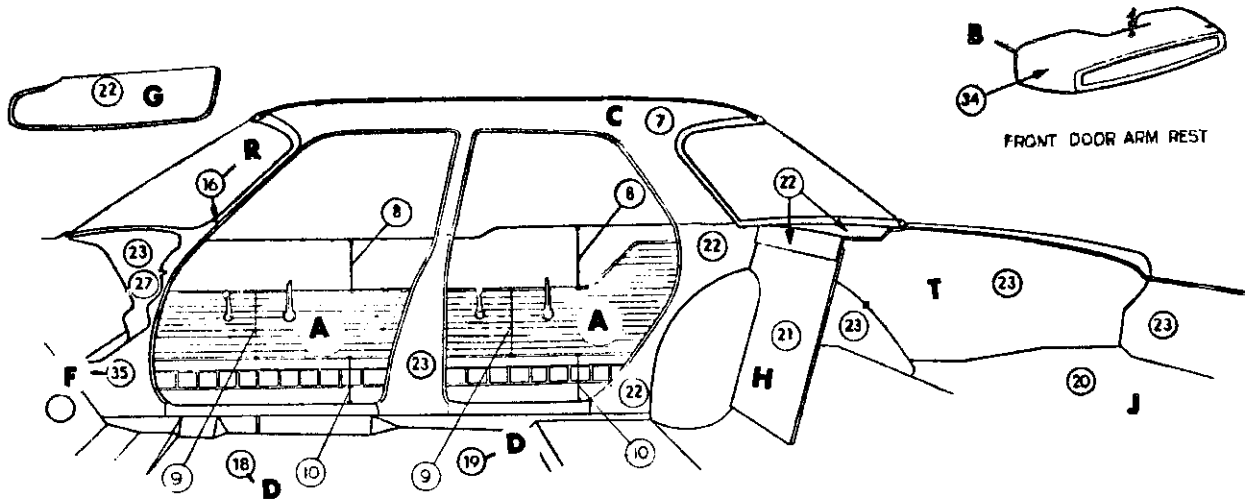

FRONT SEAT

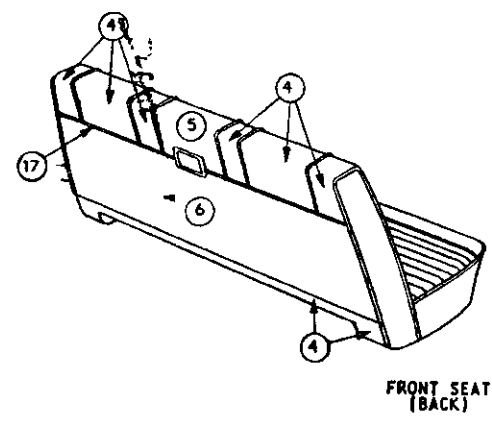

FRONT SEAT (BACK)

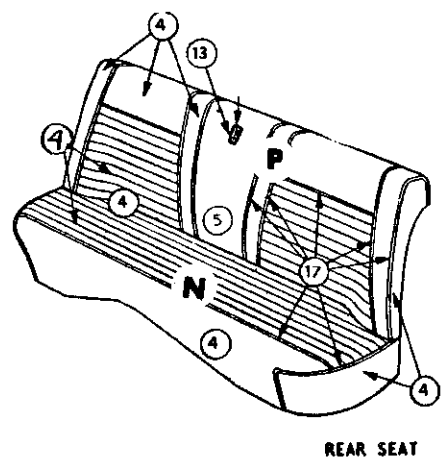

REAR SEAT

DISTRIBUTION OF MATERIAL

- 3 HEADLINING
- 4 IMITATION LEATHER 28-AM-22
- 5 IMITATION LEATHER 28A-AM-22
- 6 IMITATION LEATHER 19-C-22
- 7 IMITATION LEATHER 18-T-16
- 8 IMITATION LEATHER 19-DJ-22
- 9 IMITATION LEATHER .012-L-22
- 10 IMITATION LEATHER .012A-L-22
- 13 IMITATION LEATHER .017-L-22
- 16 LACE
- 18 FLOOR COVERING-FRONT-RUBBER
- 19 FLOOR COVERING-REAR-RUBBER
- 20 FLOOR COVERING-LUGG. COMPT. RUBBER
- 21 CARDBOARD
- 22 EMBOSSED CARDBOARD
- 23 PAINT
- 34 PLASTISOL
- 35 POLYETHLENE

Distribution Drawing Legend Page Appears Following Illustration Section

Codes 211, 214

SPL-414

1962 PLYMOUTH SP1-L, SP2-L 4 DOOR SEDAN
IMITATION LEATHER COMBINATION

1962 PLYMOUTH - S SERIES

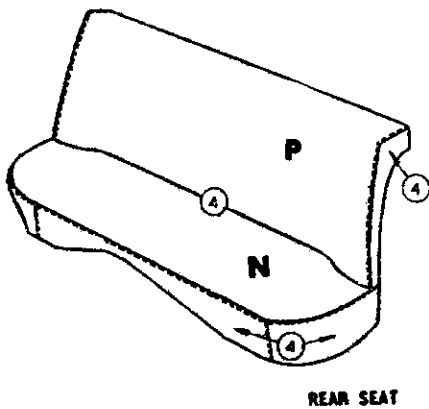
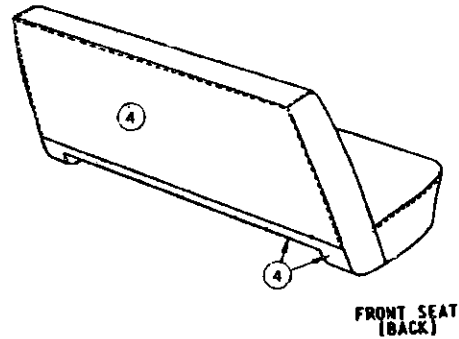
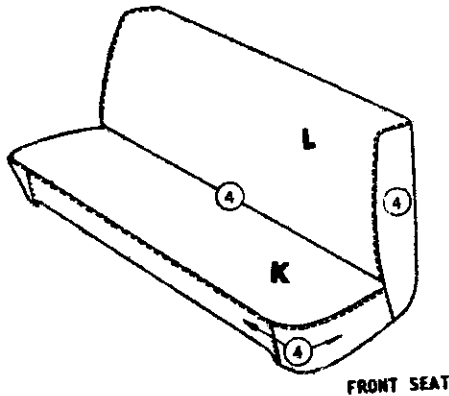
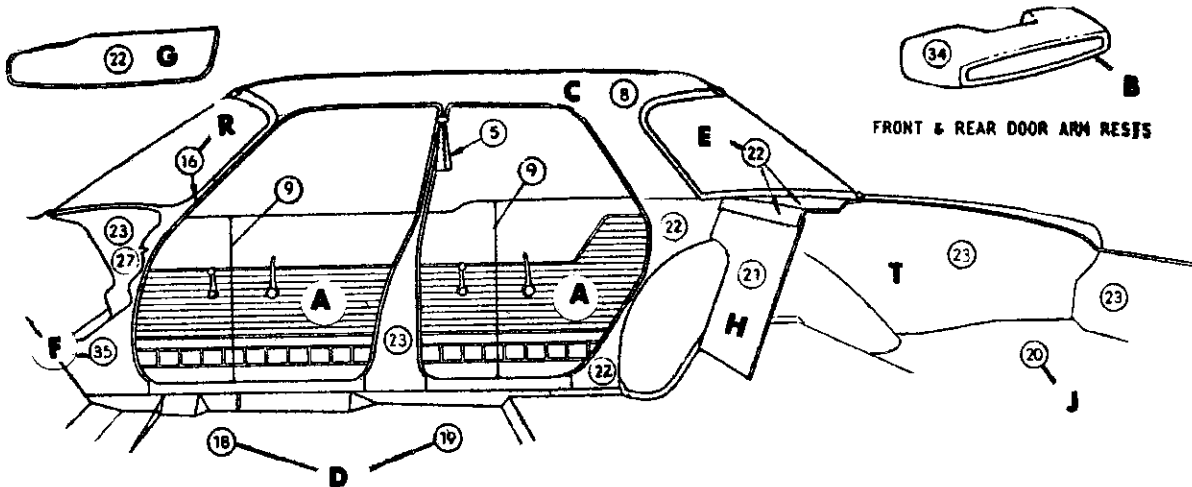

DISTRIBUTION OF MATERIAL

- 4 IMITATION LEATHER 37-CX-22
- 5 IMITATION LEATHER 19-C-22
- 8 IMITATION LEATHER 18-T-16
- 9 IMITATION LEATHER 19-DJ-22
- 16 LACE
- 18 FLOOR COVERING-FRONT-RUBBER
- 19 FLOOR COVERING-REAR-RUBBER
- 20 FLOOR COVERING-LUGG COMPT RUBBER
- 21 CARDBOARD
- 22 EMBOSSSED CARDBOARD
- 23 PAINT
- 27 MOULDED RESIN
- 34 PLASTISOL
- 35 POLYETHLENE

Distribution Drawing Legend Page Appears Following Illustration Section

Code 294

SPL-414A

1962 PLYMOUTH SP1-L, SP2-L,
SP1-M, SP2-M 4 DOOR SEDAN
IMITATION LEATHER

1962 PLYMOUTH - S SERIES

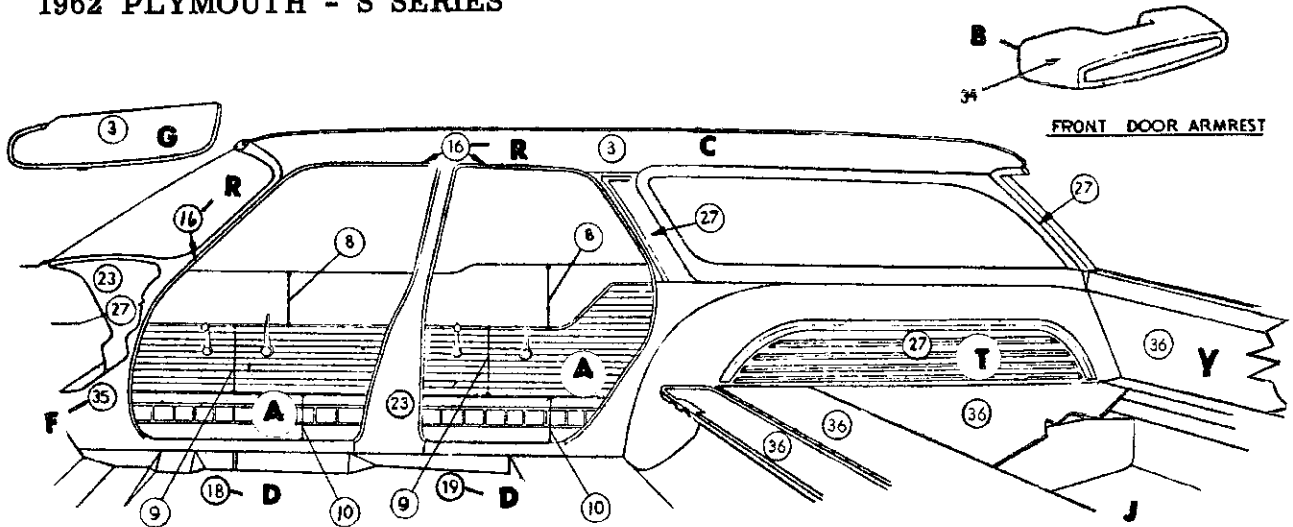

FRONT DOOR ARMREST

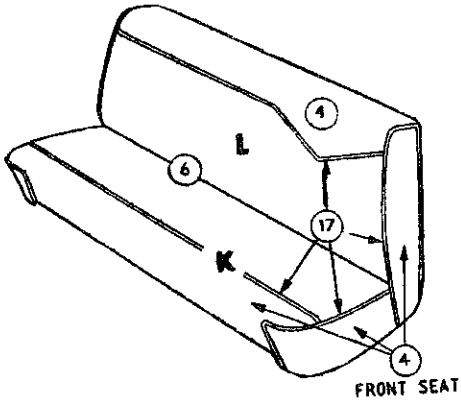

FRONT SEAT

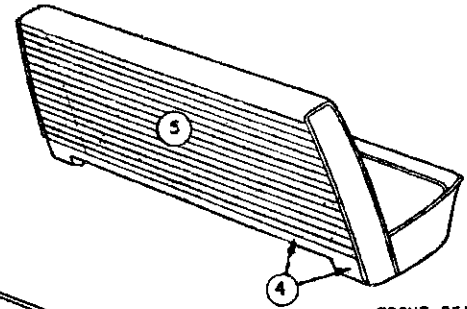

FRONT SEAT (BACK)

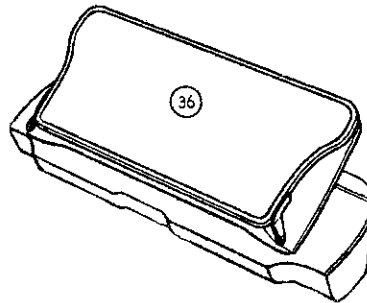

2ND SEAT (BACK)

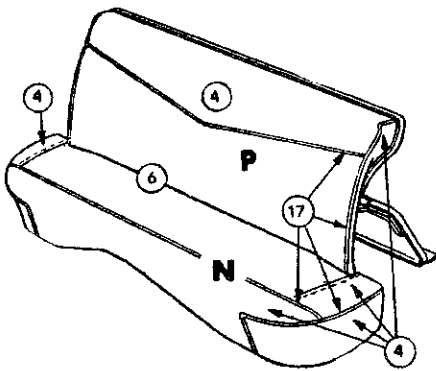

2ND SEAT

DISTRIBUTION OF MATERIAL

- 3 HEADLINING - HARDBOARD
- 4 IMITATION LEATHER 38-AM-22
- 5 IMITATION LEATHER 21-CZ-22
- 6 IMITATION LEATHER 31-DC-63
- 8 IMITATION LEATHER 19-DJ-22
- 9 IMITATION LEATHER .012-L-22
- 10 IMITATION LEATHER .012A-L-22
- 16 LACE
- 17 EXTRUDED VINYL
- 18 FLOOR COVERING-FRONT-RUBBER
- 19 FLOOR COVERING-REAR-RUBBER
- 23 PAINT
- 27 MOULDED RESIN
- 35 POLYETHYLENE
- 36 VINOLEUM

Distribution Drawing Legend Page Appears Following Illustration Section

Codes 201, 203, 204

SPL-454 1962 PLYMOUTH SP1-L, SP2-L 4 DOOR STATION WAGON
IMITATION LEATHER COMBINATION

1962 PLYMOUTH - S SERIES

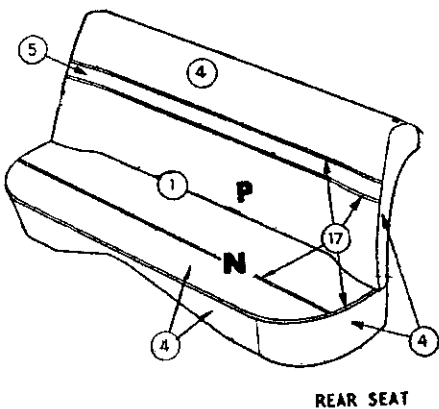
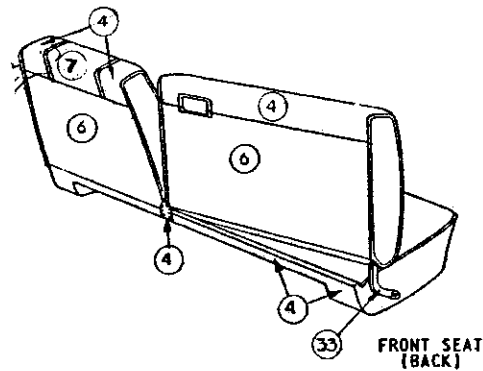
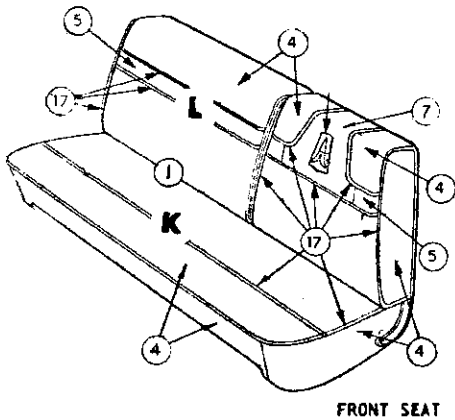
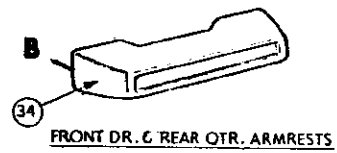
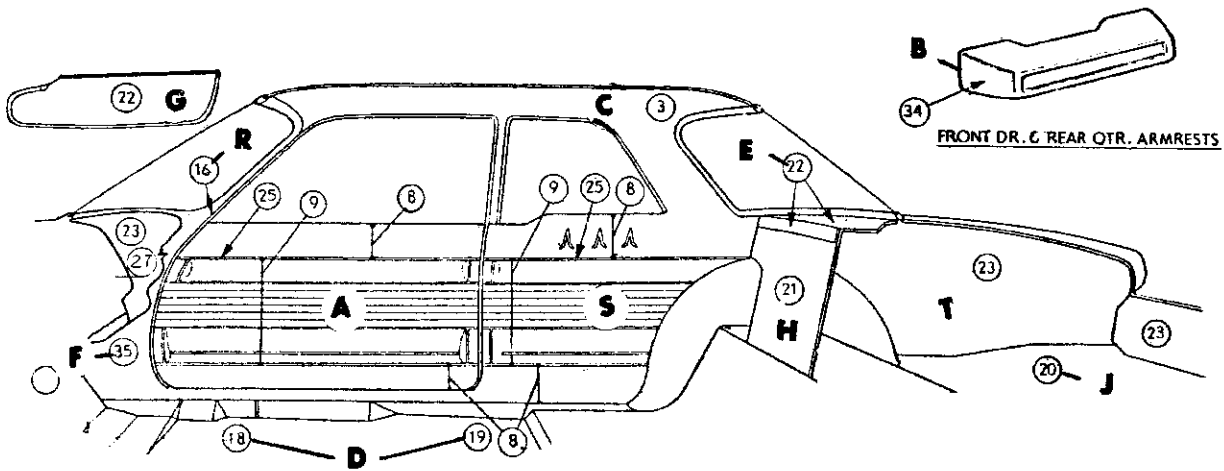

DISTRIBUTION OF MATERIAL

- 1 BODY CLOTH
- 3 HEADLINING
- 4 IMITATION LEATHER 28-AM-22
- 5 IMITATION LEATHER 28A-AM-22
- 6 IMITATION LEATHER 19-C-22
- 7 IMITATION LEATHER 49-DH-22
- 8 IMITATION LEATHER 19-DJ-22
- 9 IMITATION LEATHER 012-L-22
- 16 LACE
- 17 EXTRUDED VINYL
- 18 FLOOR COVERING-FRONT-RUBBER
- 19 FLOOR COVERING-REAR-RUBBER
- 20 FLOOR COVERING-LUGG. COMPT. RUBBER
- 21 CARDBOARD
- 22 EMBOSSED CARDBOARD
- 23 PAINT
- 25 MOULDING
- 27 MOULDED RESIN
- 33 PLASTIC
- 35 POLYETHYLENE

Distribution Drawing Legend Page Appears Following Illustration Section

Codes 111, 112, 113, 114, 115

SPM-211

1962 PLYMOUTH SP1-M, SP2-M 2 DOOR SEDAN
CLOTH AND IMITATION LEATHER COMBINATION

1962 PLYMOUTH - S SERIES

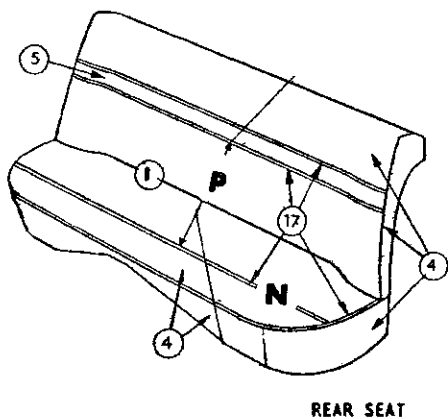
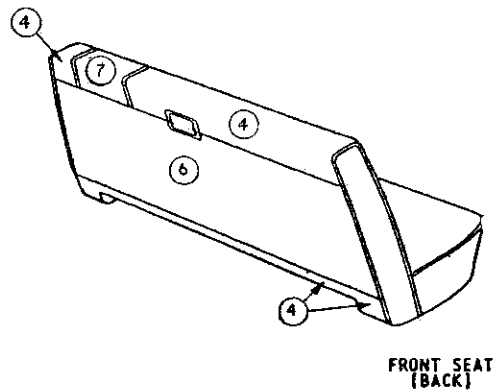
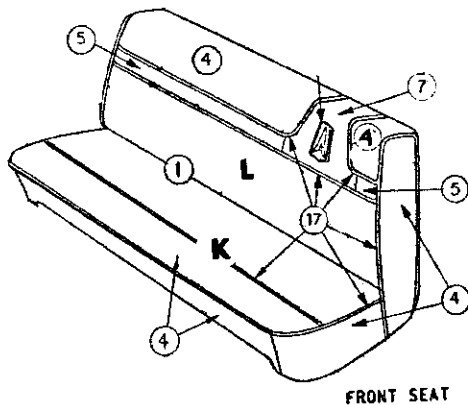
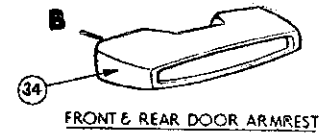
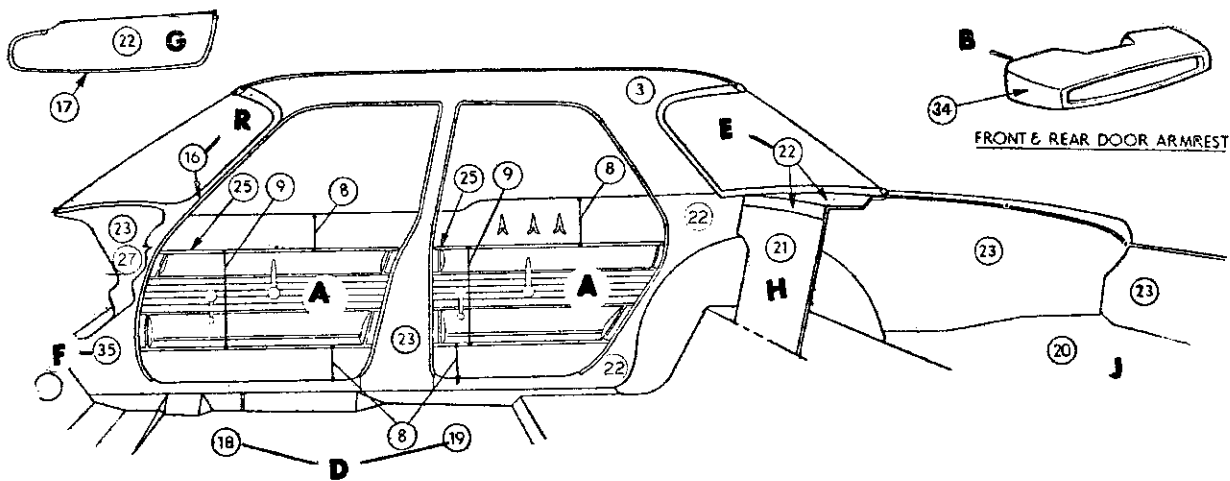

DISTRIBUTION OF MATERIAL

- 1 BODY CLOTH
- 3 HEADLINING
- 4 IMITATION LEATHER 28-AM-22
- 5 IMITATION LEATHER 28A-AM-22
- 6 IMITATION LEATHER 19-C-22
- 7 IMITATION LEATHER 49-DH-22
- 8 IMITATION LEATHER 19-DJ-22
- 9 IMITATION LEATHER .012-L-22
- 16 LACE
- 17 EXTRUDED VINYL
- 18 FLOOR COVERING-FRONT-RUBBER
- 19 FLOOR COVERING-REAR-RUBBER
- 20 FLOOR COVERING-LUGG. COMPT.
- 21 CARDBOARD
- 22 EMBOSSED CARDBOARD
- 23 PAINT
- 25 MOULDING
- 27 MOULDED RESIN
- 34 PLASTISOL
- 35 POLYETHYLENE

Distribution Drawing Legend Page Appears Following Illustration Section

Codes 111, 112, 113, 114, 115

SPM-411

1962 PLYMOUTH SP1-M, SP2-M 4 DOOR SEDAN
CLOTH AND IMITATION LEATHER COMBINATION

1962 PLYMOUTH - S SERIES

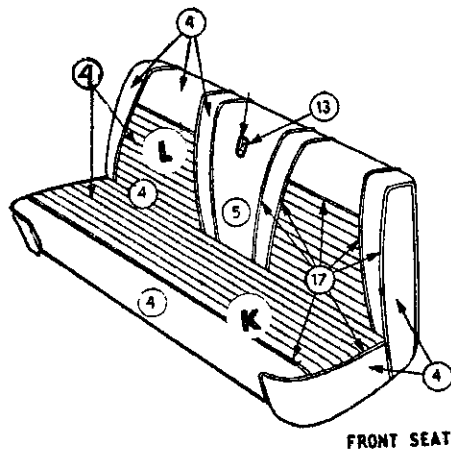
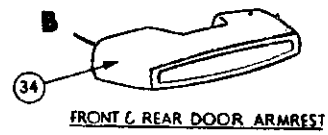
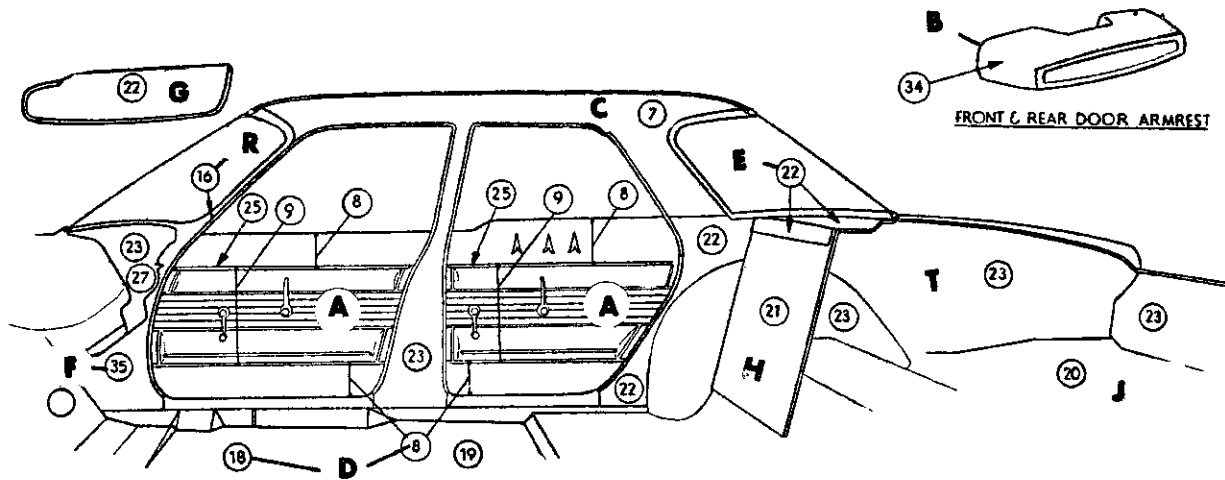

FRONT SEAT

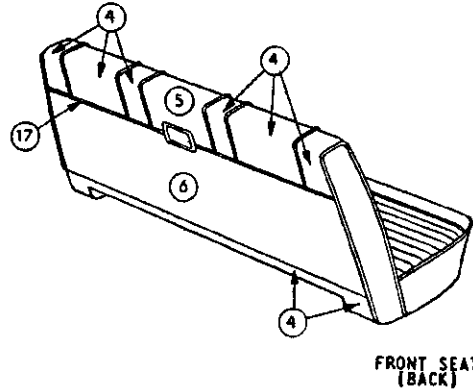

FRONT SEAT (BACK)

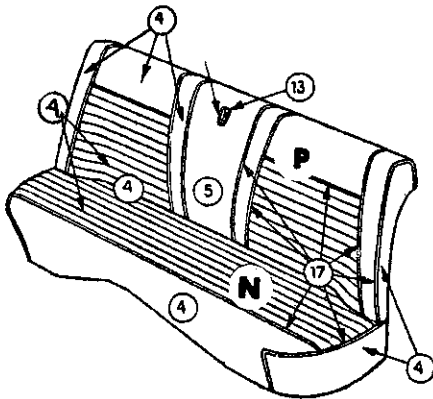

REAR SEAT

DISTRIBUTION OF MATERIAL

- 4 IMITATION LEATHER 28-AM-22
- 5 IMITATION LEATHER 28A-AM-22
- 6 IMITATION LEATHER 19-C-22
- 7 IMITATION LEATHER 18-T-16
- 8 IMITATION LEATHER 19-DJ-22
- 9 IMITATION LEATHER .014-L-22
- 13 IMITATION LEATHER .017-L-22
- 16 LACE
- 17 EXTRUDED VINYL
- 18 FLOOR COVERING-FRONT-RUBBER
- 19 FLOOR COVERING-REAR-RUBBER
- 20 FLOOR COVERING-LUGG. COMPT. RUBBER
- 21 CARDBOARD
- 22 EMBOSSED CARDBOARD
- 23 PAINT
- 24 METAL
- 25 MOULDING
- 34 PLASTISOL
- 35 POLYETHLENE

Distribution Drawing Legend Page Appears Following Illustration Section

Codes 231, 234

SPM-414

1962 PLYMOUTH SP1-M, SP2-M 4 DOOR SEDAN
IMITATION LEATHER COMBINATION

1962 PLYMOUTH - S SERIES

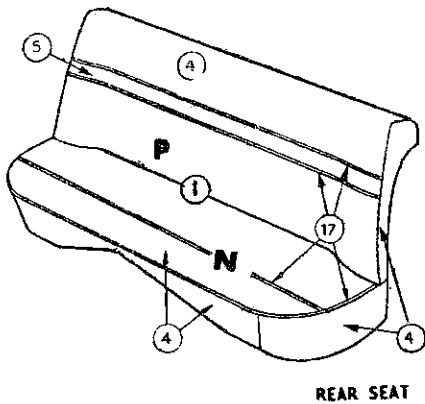
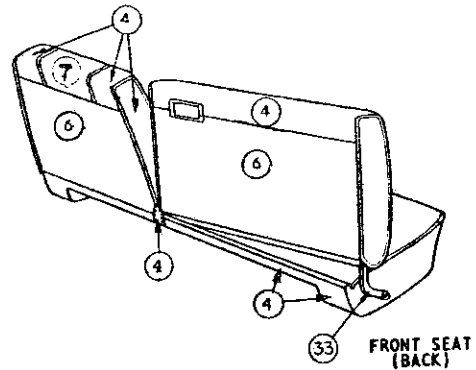
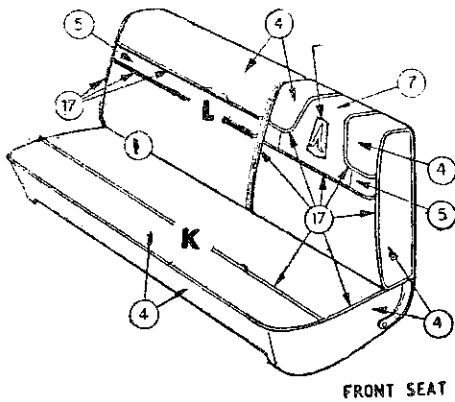
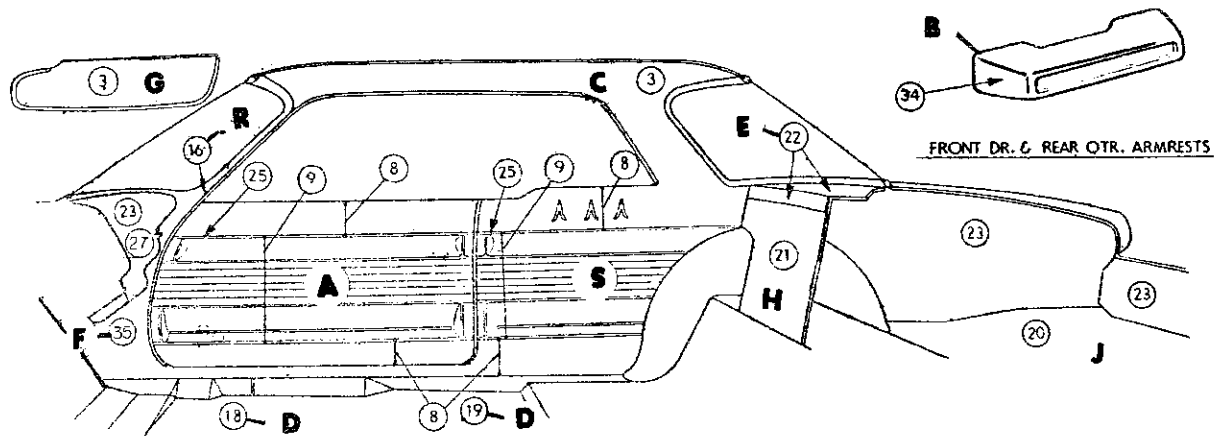

DISTRIBUTION OF MATERIAL

- 1 BODY CLOTH 1
- 3 HEADLINING - HARDBOARD
- 4 IMITATION LEATHER 28-AM-22
- 5 IMITATION LEATHER 28A-AM-22
- 6 IMITATION LEATHER 19-C-22
- 7 IMITATION LEATHER 49-DH-22
- 8 IMITATION LEATHER 19-DJ-22
- 9 IMITATION LEATHER .012-L-22
- 16 LACE
- 17 EXTRUDED VINYL
- 18 FLOOR COVERING-FRONT-RUBBER
- 19 FLOOR COVERING-REAR-RUBBER
- 20 FLOOR COVERING-LUGG. COMPT. RUBBER
- 21 CARDBOARD
- 22 EMBOSSED CARDBOARD
- 23 PAINT
- 25 MOULDING
- 27 MOULDED RESIN
- 33 PLASTIC
- 35 POLYETHYLENE

Distribution Drawing Legend Page Appears Following Illustration Section

Codes 111, 112, 113, 114, 115

SPM-231

1962 PLYMOUTH SP1-M, SP2-M 2 DOOR HARD TOP
CLOTH AND IMITATION LEATHER COMBINATION

1962 PLYMOUTH - S SERIES

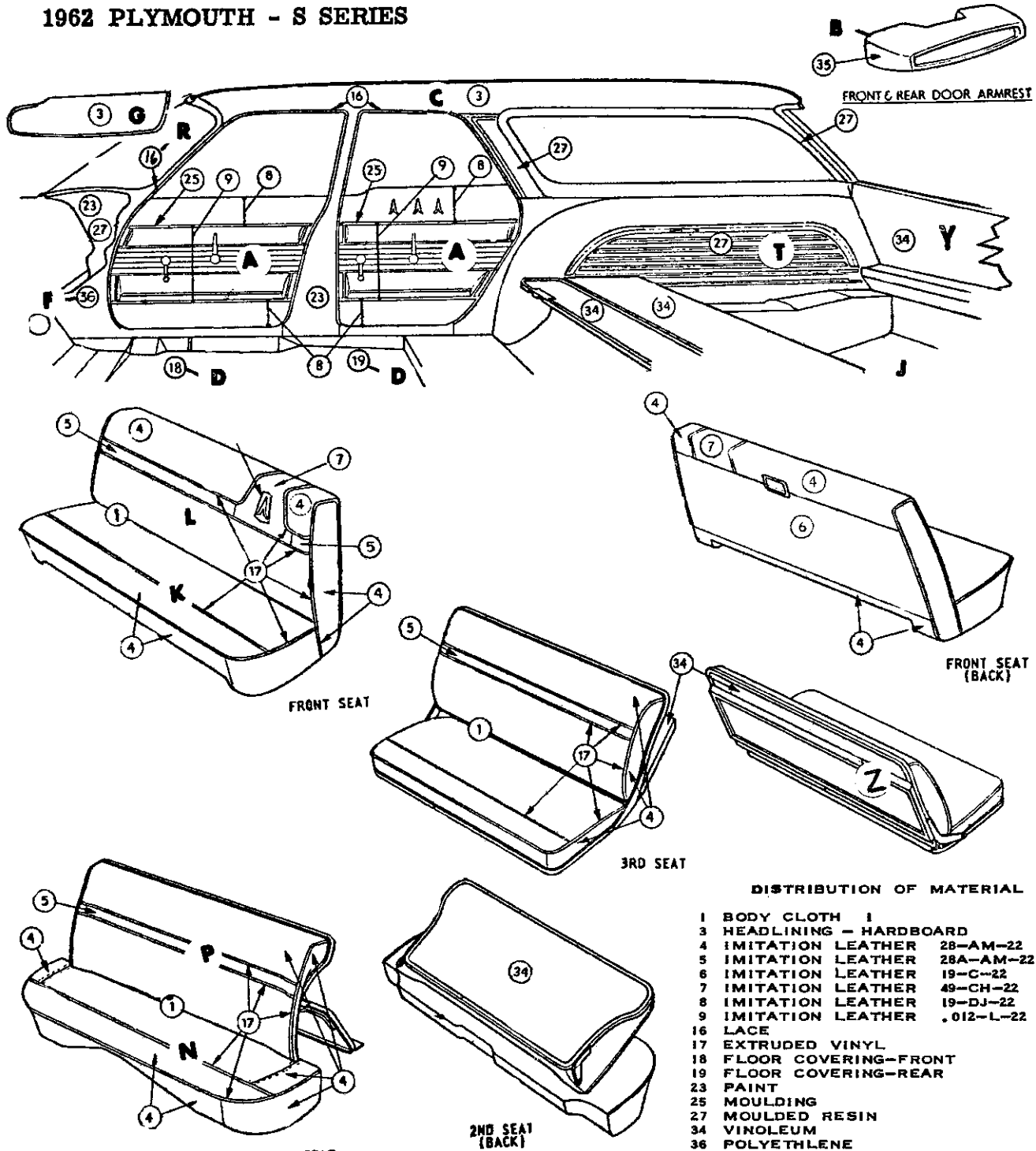

- DISTRIBUTION OF MATERIAL**
- 1 BODY CLOTH 1
 - 3 HEADLINING - HARDBOARD
 - 4 IMITATION LEATHER 28-AM-22
 - 5 IMITATION LEATHER 28A-AM-22
 - 6 IMITATION LEATHER 19-C-22
 - 7 IMITATION LEATHER 49-CH-22
 - 8 IMITATION LEATHER 19-DJ-22
 - 9 IMITATION LEATHER .012-L-22
 - 16 LACE
 - 17 EXTRUDED VINYL
 - 18 FLOOR COVERING-FRONT
 - 19 FLOOR COVERING-REAR
 - 23 PAINT
 - 25 MOULDING
 - 27 MOULDED RESIN
 - 34 VINOLEUM
 - 36 POLYETHLENE

Distribution Drawing Legend Page Appears Following Illustration Section

Codes 131, 132, 133, 134

SPM-451

1962 PLYMOUTH SP1-M, SP2-M
4 DOOR STATION WAGON
CLOTH AND IMITATION LEATHER COMBINATION

1962 PLYMOUTH - S SERIES

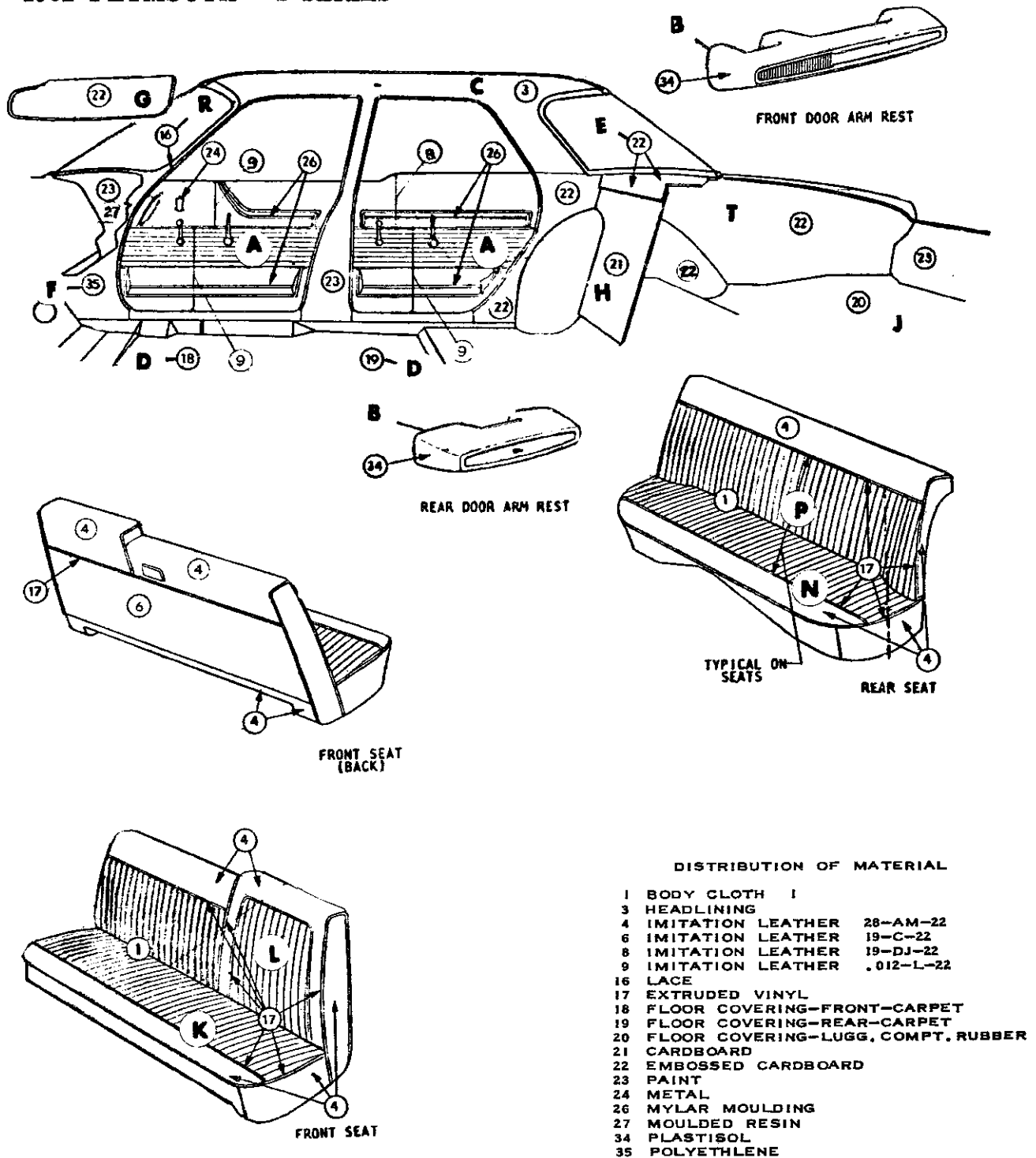

Distribution Drawing Legend Page Appears Following Illustration Section

Codes 121, 122, 123, 124, 125

SPH-411

1962 PLYMOUTH SP1-H, SP2-H 4 DOOR SEDAN
CLOTH AND IMITATION LEATHER COMBINATION

1962 PLYMOUTH - S SERIES

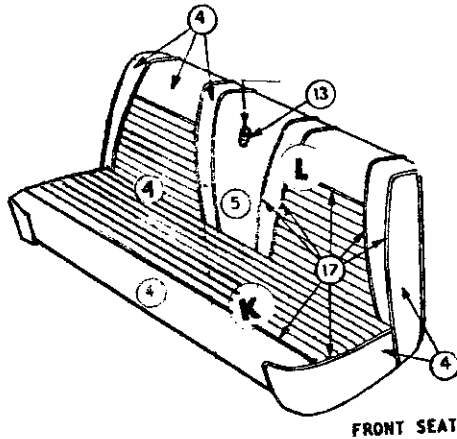
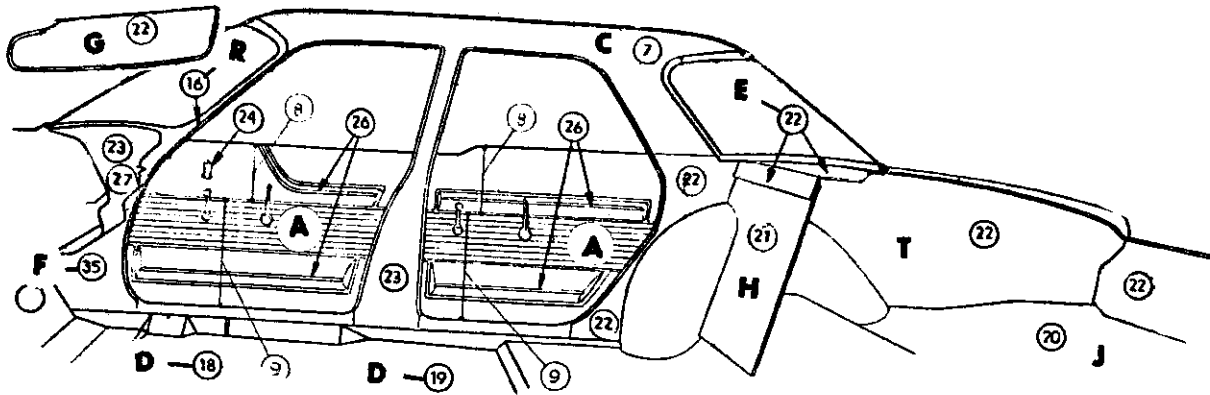

FRONT SEAT

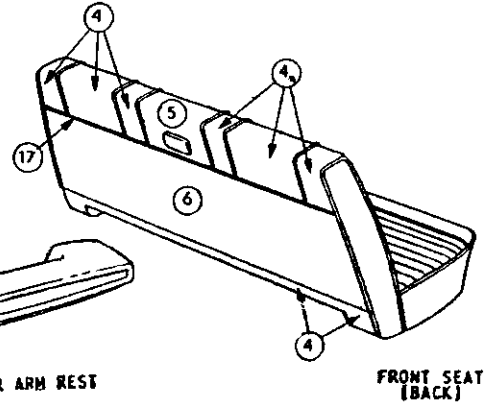

FRONT SEAT (BACK)

FRONT DOOR ARM REST

REAR DOOR ARM REST

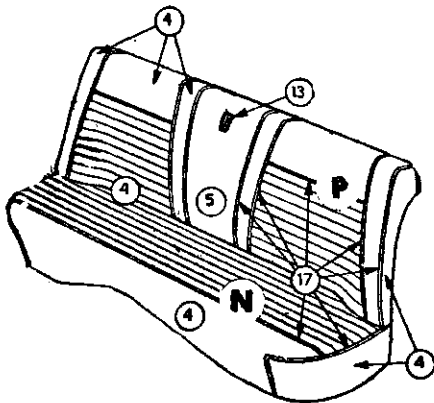

REAR SEAT

DISTRIBUTION OF MATERIAL

- 3 HEADLINING
- 4 IMITATION LEATHER 28-AM-22
- 5 IMITATION LEATHER 28A-AM-22
- 6 IMITATION LEATHER 19-C-22
- 7 IMITATION LEATHER 18-T-16
- 8 IMITATION LEATHER 19-DJ-22
- 9 IMITATION LEATHER .012-L-22
- 13 IMITATION LEATHER .017-L-22
- 16 LACE
- 18 FLOOR COVERING-FRONT-CARPET
- 19 FLOOR COVERING-REAR-CARPET
- 20 FLOOR COVERING-LUGG. COMPT. RUBBER
- 21 CARDBOARD
- 22 EMBOSSED CARDBOARD
- 23 PAINT
- 24 METAL
- 26 MYLAR MOULDING
- 27 MOULDED RESIN
- 34 PLASTISOL
- 35 POLYETHYLENE

Distribution Drawing Legend Page Appears Following Illustration Section

Codes 241, 244

SPH-414

1962 PLYMOUTH SP1-H, SP2-H 4 DOOR SEDAN
IMITATION LEATHER COMBINATION

1962 PLYMOUTH - S SERIES

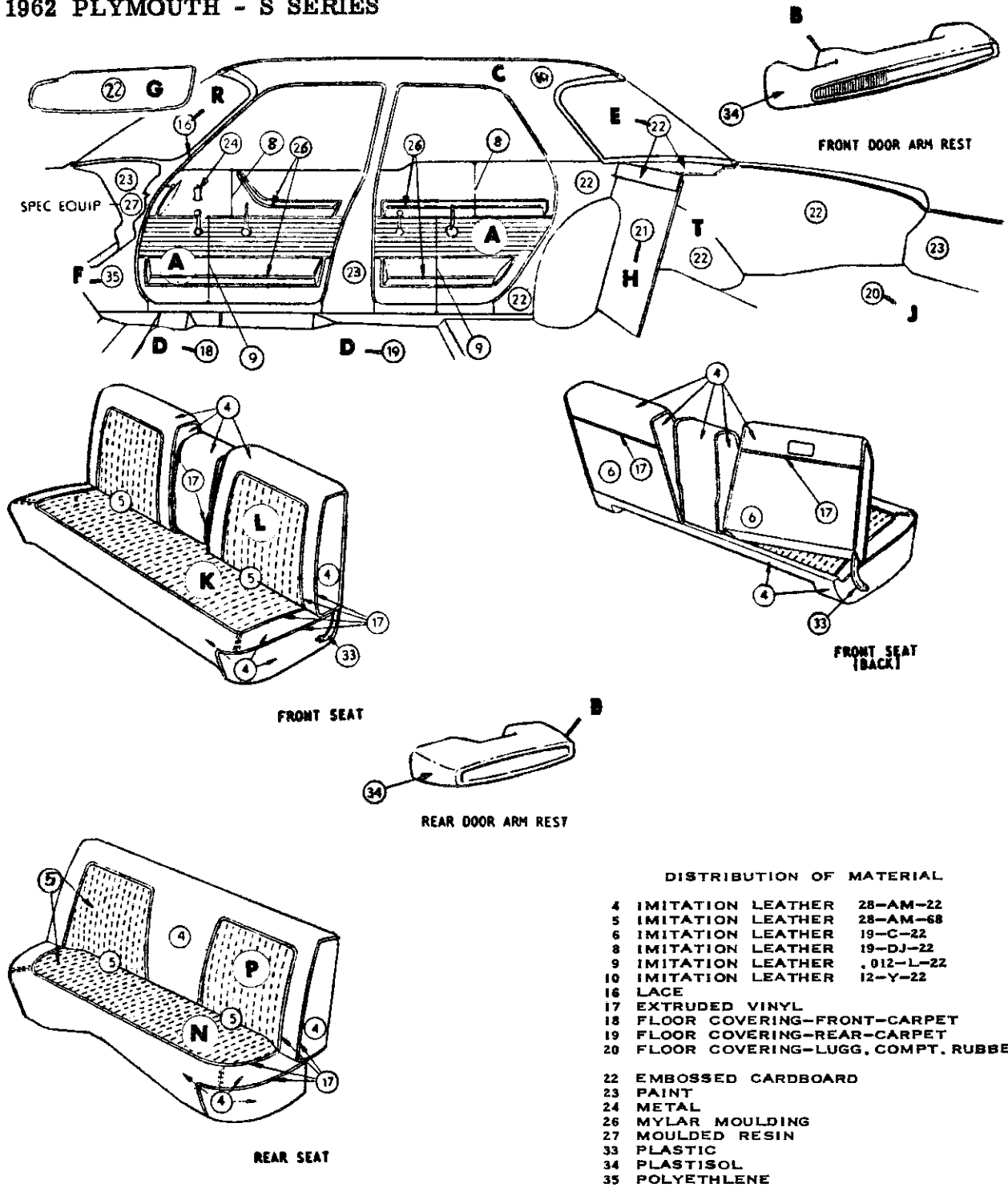

Distribution Drawing Legend Page Appears Following Illustration Section

Codes 245, 251, 253

SPH-414A

1962 PLYMOUTH SP1-H, SP2-H 4 DOOR SEDAN
IMITATION LEATHER COMBINATION

1962 PLYMOUTH - S SERIES

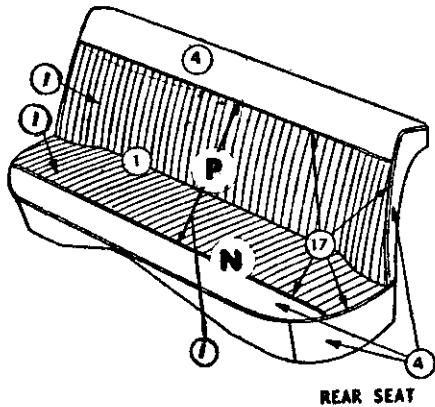
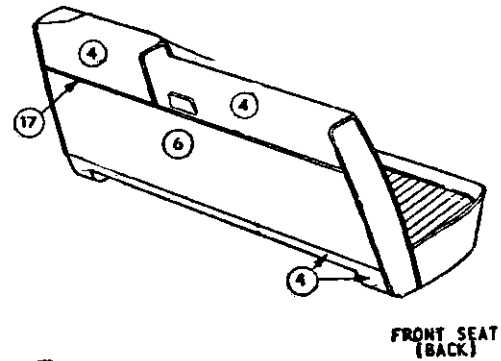
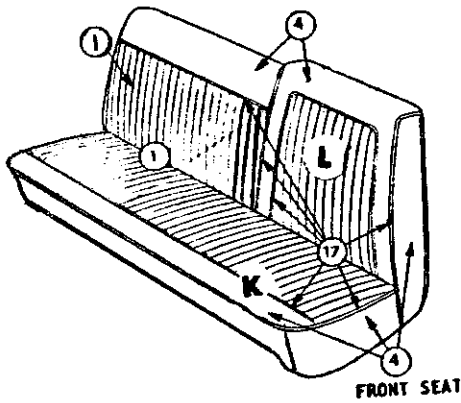
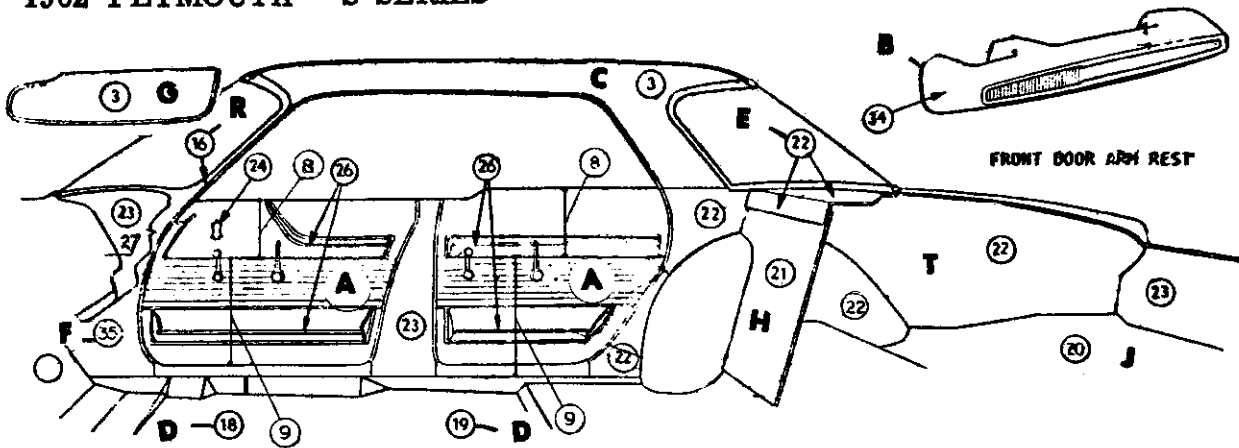

DISTRIBUTION OF MATERIAL

- 1 BODY CLOTH
- 3 HEADLINING - HARDBOARD
- 4 IMITATION LEATHER
- 6 IMITATION LEATHER
- 8 IMITATION LEATHER
- 9 IMITATION LEATHER
- 16 LACE
- 17 EXTRUDED VINYL
- 18 FLOOR COVERING-FRONT-CARPET
- 19 FLOOR COVERING-REAR-CARPET
- 20 FLOOR COVERING-LUGG. COMPT, RUBBER
- 21 CARDBOARD
- 22 EMBOSSED CARDBOARD
- 23 PAINT
- 24 METAL
- 26 MYLAR MOULDING
- 27 MOULDED RESIN
- 34 PLASTISOL
- 35 POLYETHYLENE

Distribution Drawing Legend Page Appears Following Illustration Section

Codes 121, 122, 123, 124, 125

SPH-431 1962 PLYMOUTH SP1-H, SP2-H SPECIAL 4 DOOR SEDAN
CLOTH AND IMITATION LEATHER COMBINATION

1962 PLYMOUTH - S SERIES

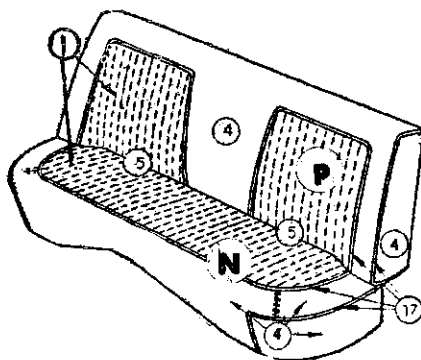
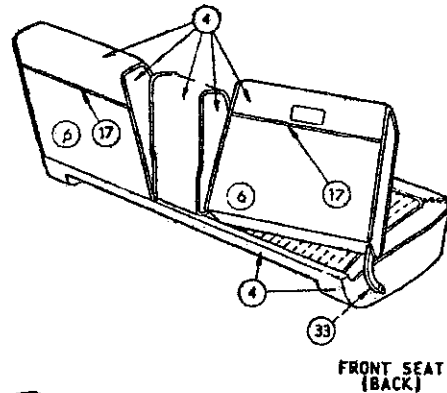
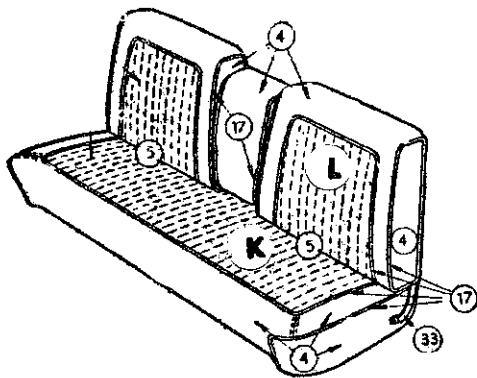
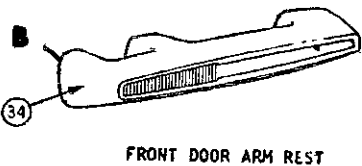
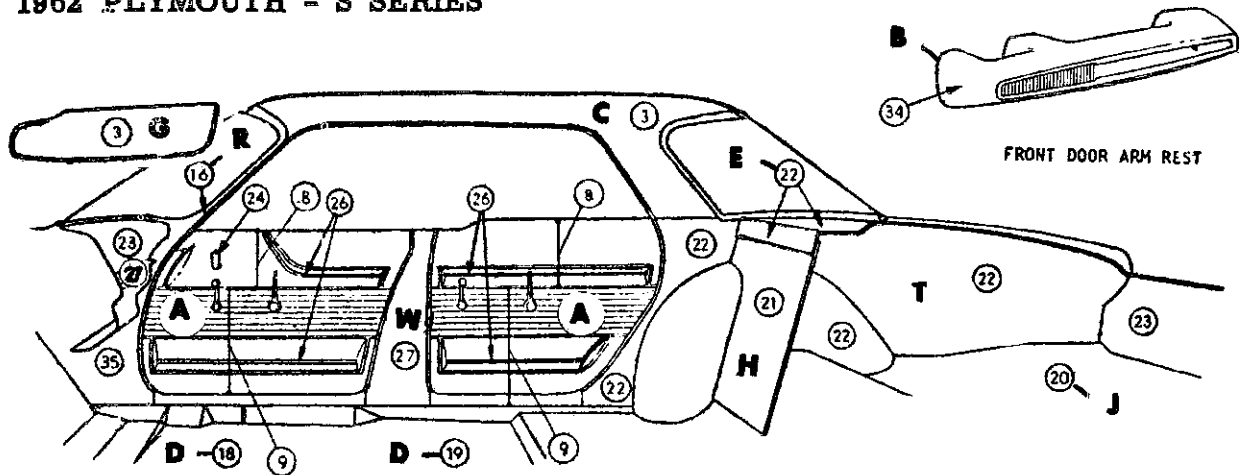

DISTRIBUTION OF MATERIAL

- 3 HEADLINING - HARDBOARD
- 4 IMITATION LEATHER 28-AM-22
- 5 IMITATION LEATHER 28-AM-68
- 6 IMITATION LEATHER 19-C-22
- 8 IMITATION LEATHER 19-DJ-22
- 9 IMITATION LEATHER .012-L-22
- 16 LACE
- 18 FLOOR COVERING-FRONT-CARPET
- 19 FLOOR COVERING-REAR-CARPET
- 20 FLOOR COVERING-LUGG. COMPT. RUBBER
- 21 CARDBOARD
- 22 EMBOSSED CARDBOARD
- 23 PAINT
- 24 METAL
- 26 MYLAR MOULDING
- 27 MOULDED RESIN
- 33 PLASTIC
- 34 PLASTISOL
- 35 POLYEHTLENE

Distribution Drawing Legend Page Appears Following Illustration Section

Codes 245, 251, 253

SPH-434 1962 PLYMOUTH SP1-H, SP2-H SPECIAL 4 DOOR SEDAN
IMITATION LEATHER COMBINATION

1962 PLYMOUTH - S SERIES

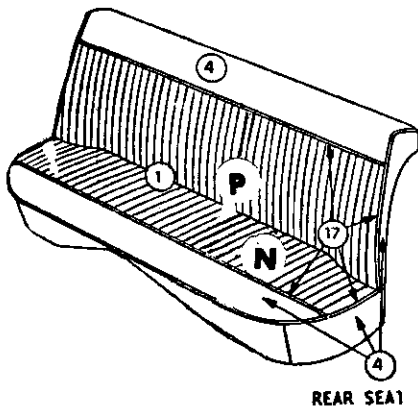
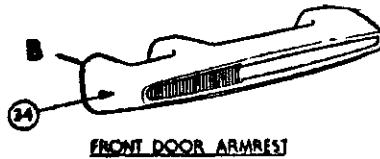
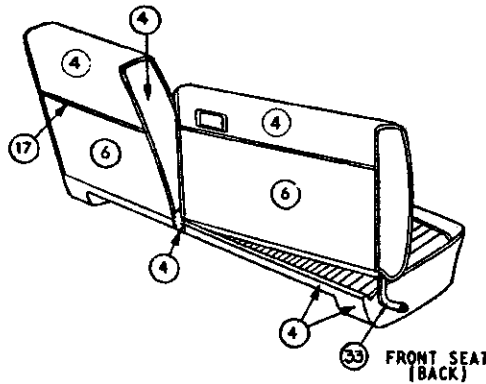
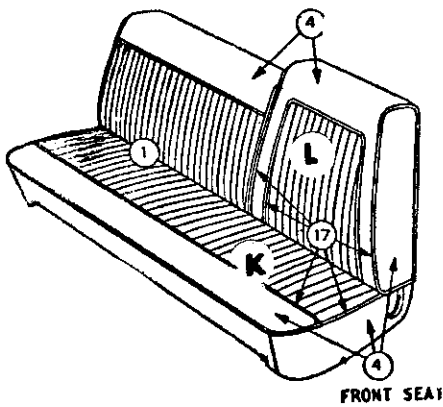
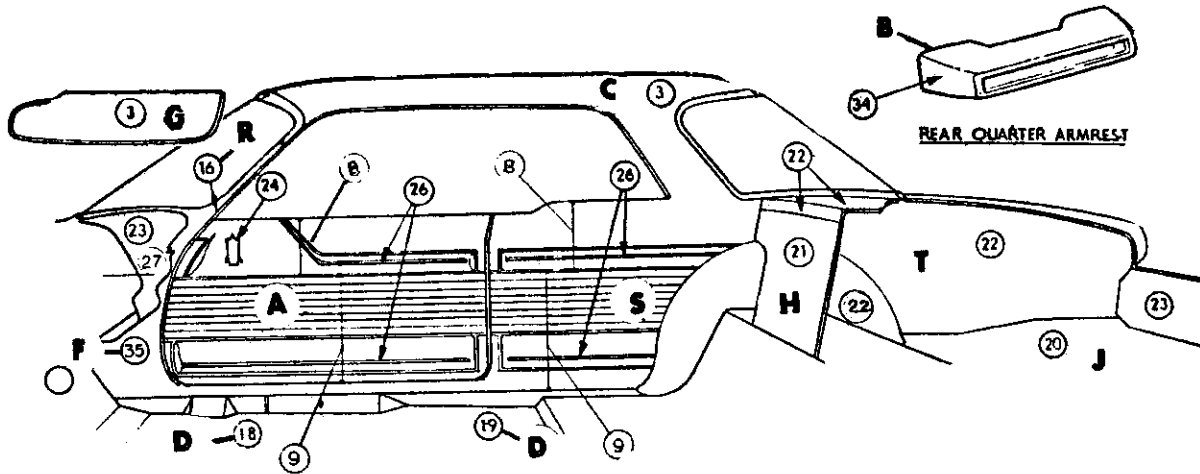

DISTRIBUTION OF MATERIAL

- 1 BODY CLOTH
- 3 HEADLINING - HARDBOARD
- 4 IMITATION LEATHER 28-AM-22
- 6 IMITATION LEATHER 19-C-22
- 8 IMITATION LEATHER 19-DJ-22
- 9 IMITATION LEATHER .012-L-22
- 16 LACE
- 18 FLOOR COVERING-FRONT-CARPET
- 19 FLOOR COVERING-REAR-CARPET
- 20 FLOOR COVERING-LUGG. COMPT, RUBBER
- 21 CARDBOARD
- 22 EMBOSSED CARDBOARD
- 23 PAINT
- 24 METAL
- 26 MYLAR MOULDING
- 27 MOULDED RESIN
- 33 PLASTIC
- 35 POLYETHLENE

Distribution Drawing Legend Page Appears Following Illustration Section

Codes 121, 122, 123, 124, 125

SPH-231 1962 PLYMOUTH SP1-H, SP2-H SPECIAL CLUB COUPE
CLOTH AND IMITATION LEATHER COMBINATION

1962 PLYMOUTH - S SERIES

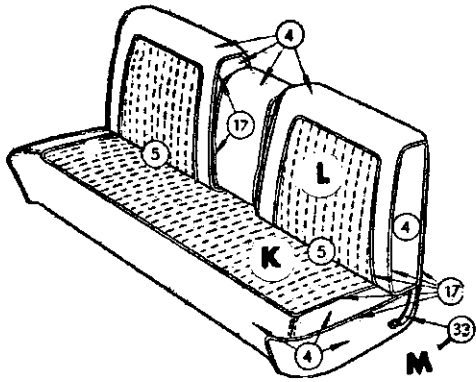
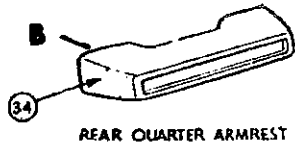
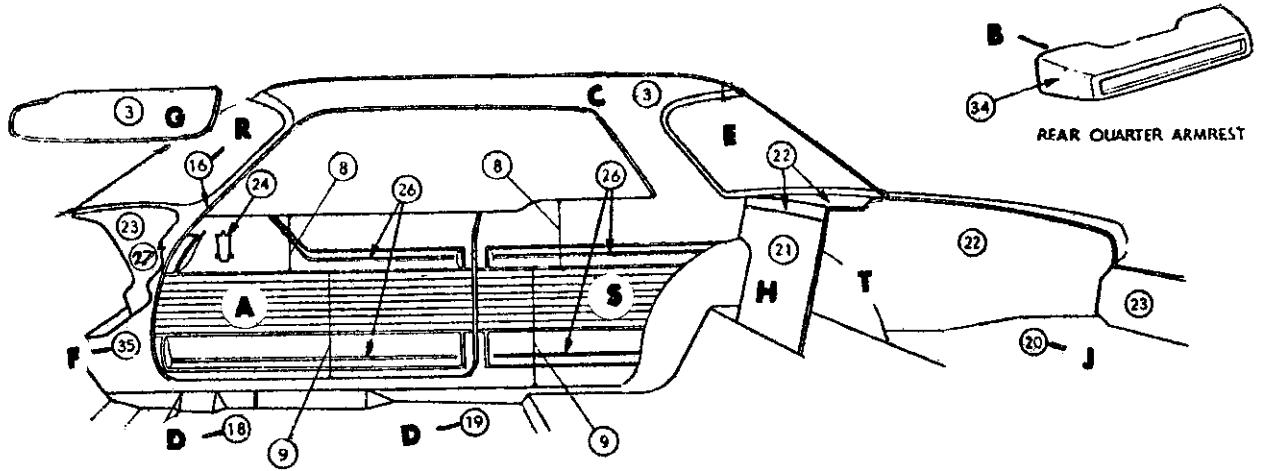

FRONT SEAT

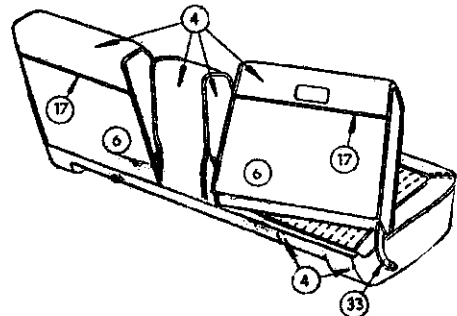

FRONT SEAT (BACK)

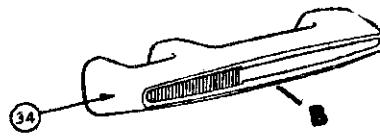

FRONT DOOR ARMREST

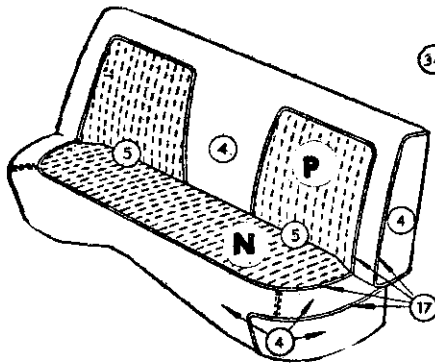

REAR SEAT

DISTRIBUTION OF MATERIAL

- 3 HEADLINING - HARDBOARD
- 4 IMITATION LEATHER 28-AM-22
- 5 IMITATION LEATHER 28-AM-68
- 6 IMITATION LEATHER 19-C-22
- 8 IMITATION LEATHER 19-DJ-22
- 9 IMITATION LEATHER 012-L-22
- 16 LACE
- 17 EXTRUDED VINYL
- 18 FLOOR COVERING-FRONT-CARPET
- 19 FLOOR COVERING-REAR-CARPET
- 20 FLOOR COVERING-LUGG COMPRT RUBBER
- 21 CARDBOARD
- 22 EMBOSSD CARDBOARD
- 23 PAINT
- 24 METAL
- 26 MYLAR MOULDING
- 27 MOULDED RESIN
- 33 PLASTIC
- 34 PLASTISOL

Distribution Drawing Legend Page Appears Following Illustration Section

Codes 245, 251, 253

SPH-234 1962 PLYMOUTH SP1-H, SP2-H SPECIAL CLUB COUPE
IMITATION LEATHER COMBINATION

1962 PLYMOUTH - S SERIES

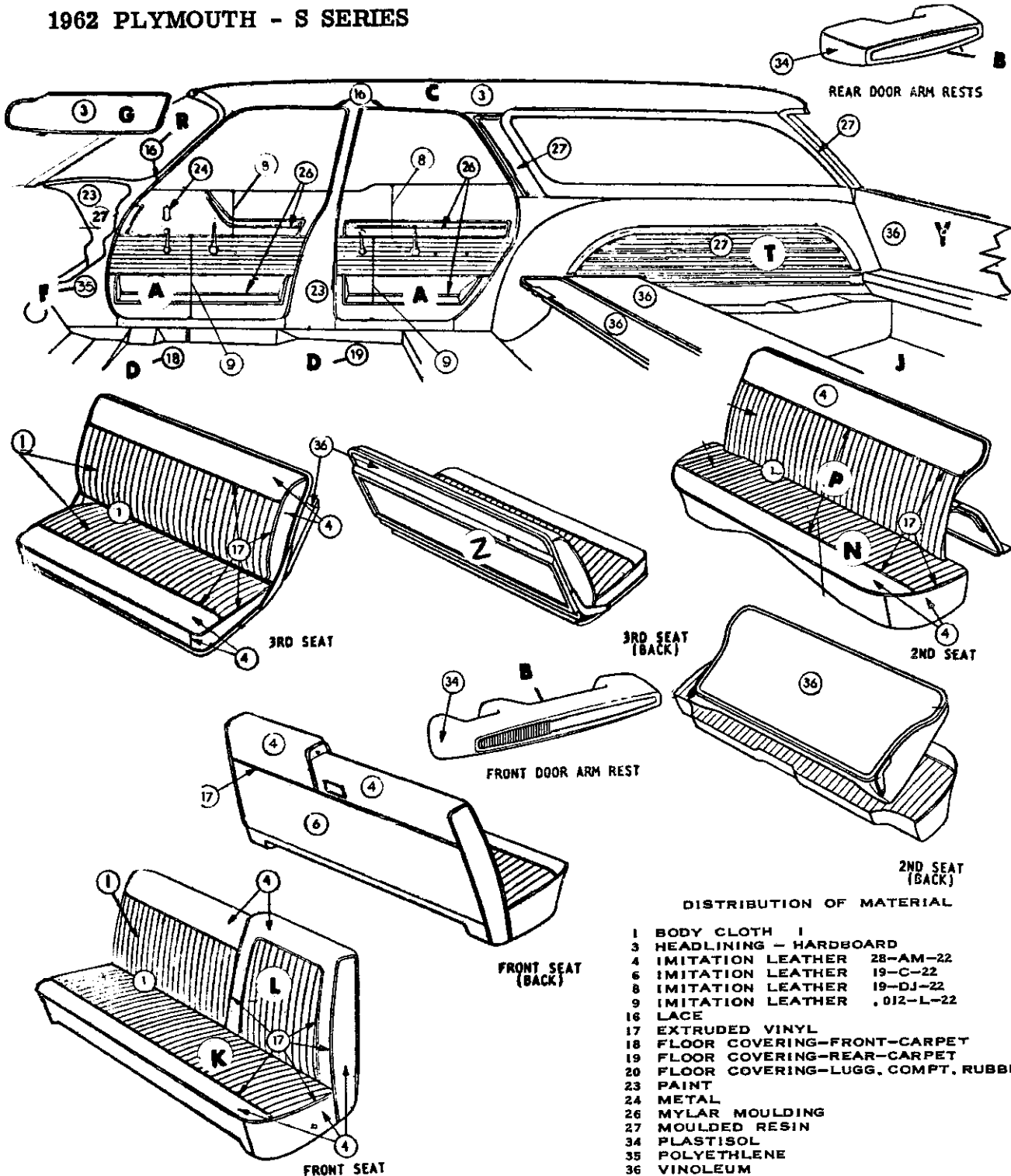

Distribution Drawing Legend Page Appears Following Illustration Section

Codes 121, 122, 123, 124, 125

SPH-451

1962 PLYMOUTH SP2-H 4 DOOR STATION WAGON
CLOTH AND IMITATION LEATHER COMBINATION

1962 PLYMOUTH - S SERIES

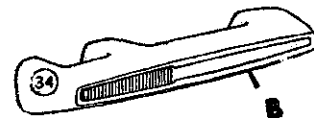
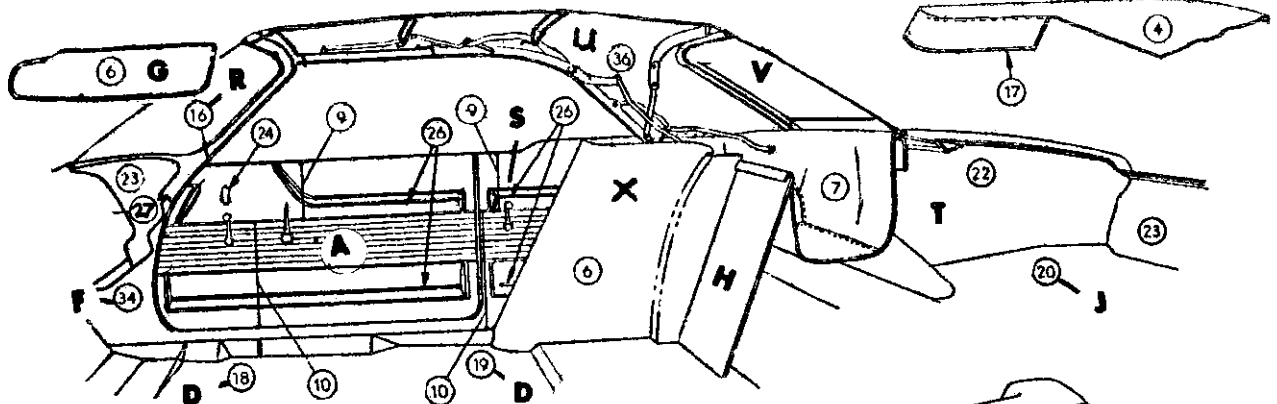

DOOR ARM REST

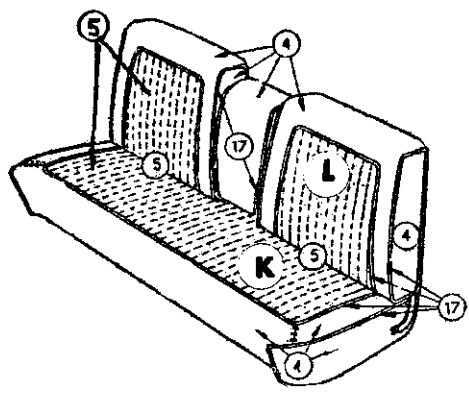

FRONT SEAT

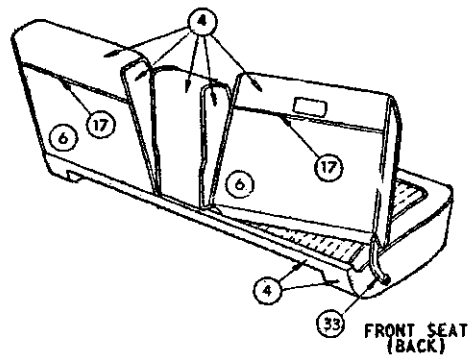

FRONT SEAT (BACK)

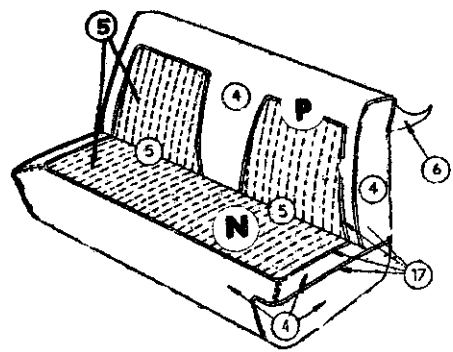

REAR SEAT

DISTRIBUTION OF MATERIAL

- 4 IMITATION LEATHER 28-AM-22
- 5 IMITATION LEATHER 28-AM-68
- 6 IMITATION LEATHER 19-C-22
- 7 IMITATION LEATHER 19A-C-22
- 9 IMITATION LEATHER 19-DJ-22
- 10 IMITATION LEATHER .012-L-22
- 16 LACE
- 17 EXTRUDED VINYL
- 18 FLOOR COVERING-FRONT-CARPET
- 19 FLOOR COVERING-REAR-CARPET
- 20 FLOOR COVERING-LUGG. COMPT. RUBBER
- 22 EMBOSSED CARDBOARD
- 23 PAINT
- 24 METAL
- 26 MYLAR MOULDING
- 27 MOULDED RESIN
- 33 PLASTIC
- 34 POLYETHLENE
- 36 TOP MATERIAL

Distribution Drawing Legend Page Appears Following Illustration Section

Codes 245, 251, 253, 254

SPH-274A

1962 PLYMOUTH SP2-H CONVERTIBLE COUPE
IMITATION LEATHER TRIM

1962 PLYMOUTH - S SERIES

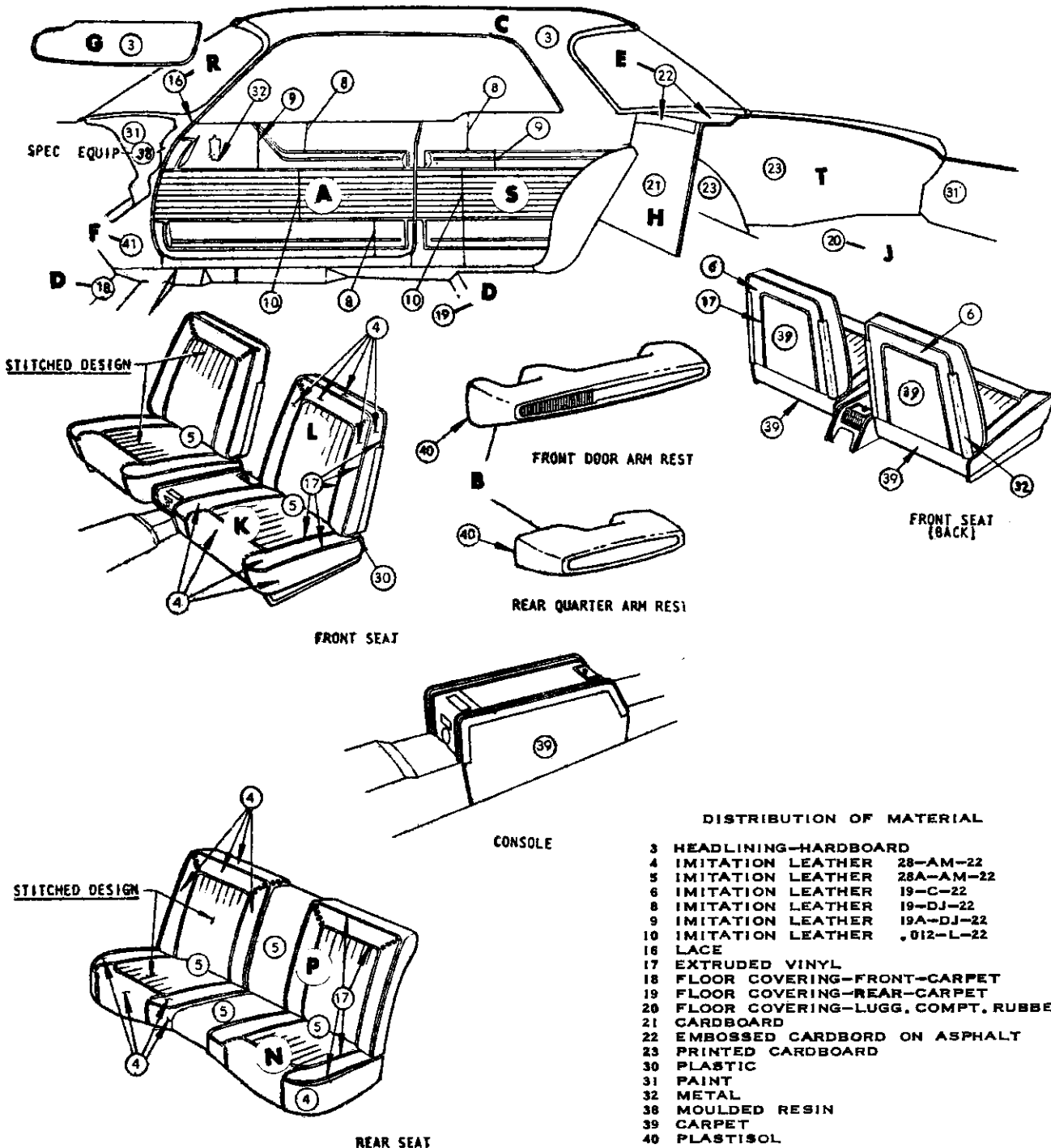

DISTRIBUTION OF MATERIAL

- 3 HEADLINING-HARDBOARD
- 4 IMITATION LEATHER 28-AM-22
- 5 IMITATION LEATHER 28A-AM-22
- 6 IMITATION LEATHER 19-C-22
- 8 IMITATION LEATHER 19-DJ-22
- 9 IMITATION LEATHER 19A-DJ-22
- 10 IMITATION LEATHER .012-L-22
- 16 LACE
- 17 EXTRUDED VINYL
- 18 FLOOR COVERING-FRONT-CARPET
- 19 FLOOR COVERING-REAR-CARPET
- 20 FLOOR COVERING-LUGG. COMPT. RUBBER
- 21 CARDBOARD
- 22 EMBOSSED CARDBORD ON ASPHALT
- 23 PRINTED CARDBOARD
- 30 PLASTIC
- 31 PAINT
- 32 METAL
- 38 MOULDED RESIN
- 39 CARPET
- 40 PLASTISOL

Distribution Drawing Legend Page Appears Following Illustration Section

Codes 261, 263, 265

SPP-234

1962 PLYMOUTH SP2-P SPECIAL CLUB COUPE
IMITATION LEATHER

1962 PLYMOUTH - S SERIES

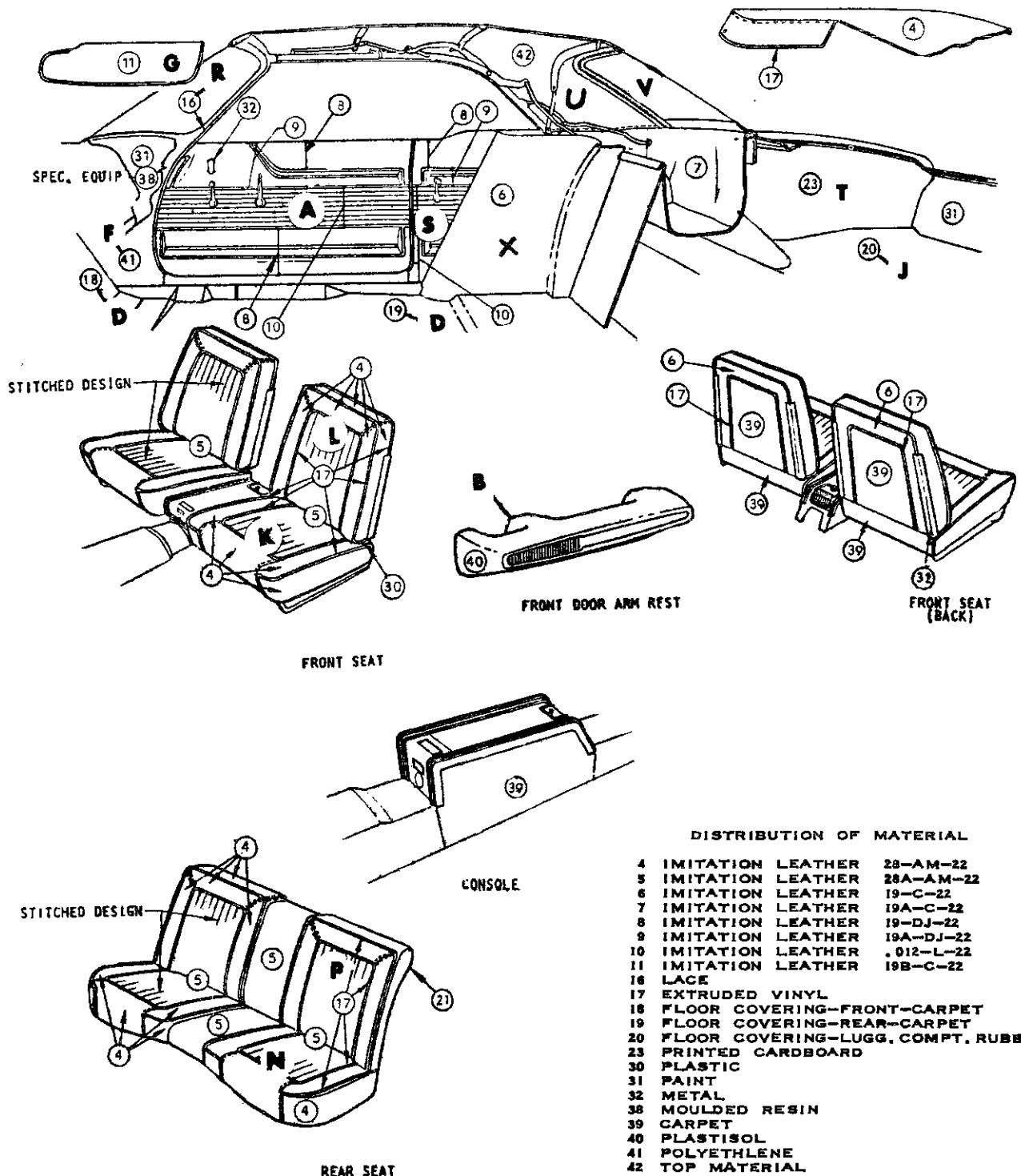

Distribution Drawing Legend Page Appears Following Illustration Section

Codes 261, 263, 265

SPP-274

1962 PLYMOUTH SP2-P CONVERTIBLE COUPE
IMITATION LEATHER TRIM

1962 PLYMOUTH - S SERIES

Distribution Drawing Legend

See Illustrations For Letter Identification

Letter	Description	Code
A	Panel, Door Trim	23-92-5
B	Arm Rest, Door, Front	23-76-3
	Center, Front Seat	23-76-34
	Door, Rear	23-76-59
	Quarter Panel	23-76-66
C	Headlining	23-86-3
D	Floor Cover, Front, Carpet	23-79-3
	Rubber	23-20-8
	Rear, Carpet	23-79-33
	Rubber	23-20-41
E	Panel, Shelf Trim	23-102-3
F	Panel, Cowl Trim	23-91-6
G	Visor	23-103-3
H	Panel, Luggage Compartment Front	23-96-3
J	Cover, Luggage Compartment Floor	23-20-29
K	Cover, Front Seat Cushion	23-108-5
L	Cover, Front Seat Back	23-108-16
M	Cover, Front Seat Hinge	23-108-84
N	Cover, Rear Seat Cushion	23-109-36
P	Cover, Rear Seat Back	23-109-4
Q	Cover, Rear Seat Cushion Bottom Panel	23-109-40
R	Weathercord, Door	23-113-2
	Hinge Pillar	23-113-25
	Lock Pillar	23-113-30
	w/Weatherstrip	23-66-33
S	Panel, Quarter Trim	23-101-3
T	Cover, Wheelhouse	23-96-8
U	Top Deck and Side Quarter	23-112-108
V	Curtain, Folding Top Back	23-112-45
W	Cover, Center Pillar	23-99-4
X	Panel, Folding Top Well Pocket	23-112-153
Y	Cover, Tailgate Inside Panel	23-79-79
Z	Cover, Rear Seat Back Panel	23-109-5

BODY CODE

COLUMN LEGEND

SAVOY (SP1-L)

201 (21)	2 D. Sedan (Fleet)
203 (41)	4 D. Sedan (Fleet)
211 (21)	2 D. Sedan
213 (41)	4 D. Sedan
256 (45A)	4 D. Wagon (2 Seat)
283 (41)	4 D. Sedan (Taxi)
291 (21)	2 D. Sedan (Police)
293 (41)	4 D. Sedan (Police)
296 (45A)	4 D. Wagon (Police-2 Seat)

BELVEDERE (SP1-M)

221 (21)	2 D. Sedan
222 (23)	2 D. Hard Top
223 (41)	4 D. Sedan
266 (45A)	4 D. Wagon (2 Seat)

FURY (SP1-H)

232 (23)	2 D. Hard Top
233 (41)	4 D. Sedan

SAVOY (SP2-L)

301 (21)	2 D. Sedan (Fleet)
303 (41)	4 D. Sedan (Fleet)
311 (21)	2 D. Sedan
313 (41)	4 D. Sedan
356 (45A)	4 D. Wagon (2 Seat)
383 (41)	4 D. Sedan (Taxi)
391 (21)	2 D. Sedan (Police)
393 (41)	4 D. Sedan (Police)
396 (45A)	4 D. Wagon (Police-2 Seat)

BELVEDERE (SP2-M)

321 (21)	2 D. Sedan
322 (23)	2 D. Hard Top
323 (41)	4 D. Sedan
366 (45A)	4 D. Wagon (2 Seat)
367 (45B)	4 D. Wagon (3 Seat)

FURY (SP2-H)

332 (23)	2 D. Hard Top
333 (41)	4 D. Sedan
334 (43)	4 D. Hard Top
335 (27)	Convertible
376 (45A)	4 D. Wagon (2 Seat)
377 (45B)	4 D. Wagon (3 Seat)

SPORT FURY (SP2-P)

342 (23)	2 D. Hard Top
345 (27)	Convertible

★ Indicates use as required.
 □ Indicates parts not listed in any previous parts book.
 Right and left part numbers are on same line,
 first number is right, second number is left.
 * Indicates change or addition.

CONVERTIBLE TOP COLOR LEGEND

6 Black

7 White

9 Special

STARTING SERIAL NUMBERS

	Detroit Built	St. Louis Built	Newark Built	Los Angeles Built
SP1-L (Savoy)	2121-100001	2127-100001	2126-100001	2125-100001
SP1-L (Savoy Sub.)	2521-100001	2527-100001	2526-100001	2525-100001
SP1-M (Belvedere)	2221-100001	2227-100001	2226-100001	2225-100001
SP1-M (Belvedere Sub.)	2621-100001	2627-100001	2626-100001	2625-100001
SP1-H (Fury)	2321-100001	2327-100001	2326-100001	2325-100001
SP2-L (Savoy)	3121-100001	3127-100001	3126-100001	3125-100001
SP2-L (Savoy Sub.)	3521-100001	3527-100001	3526-100001	3525-100001
SP2-M (Belvedere)	3221-100001	3227-100001	3226-100001	3225-100001
SP2-M (Belvedere Sub.)	3621-100001	3627-100001	3626-100001	3625-100001
SP2-H (Fury)	3321-100001	3327-100001	3326-100001	3325-100001
SP2-H (Fury Sub.)	3721-100001	3727-100001	3726-100001	3725-100001
SP2-P (Fury Sport)	3421-100001	3427-100001	3426-100001	3425-100001

TRIM CODE	MODEL	MATERIAL			COLOR	4 D. Sed.	4 D. Sed. Special	Sub. 2 D. Sed.	Spec. Club Cpe.	Conv. Cpe.
		Cloth	Vinyl	Leather						
101	P1-L, P2-L	★	★	-	Blue	★	-	★	-	-
103	P1-L, P2-L	★	★	-	Cocoa	★	-	★	-	-
104	P1-L, P2-L	★	★	-	Gray	★	-	★	-	-
111	P1-M, P2-M	★	★	-	Blue	★	-	★	★	-
112	P1-M, P2-M	★	★	-	Green	★	-	★	★	-
113	P1-M, P2-M	★	★	-	Cocoa	★	-	★	★	-
114	P1-M, P2-M	★	★	-	Gray	★	-	★	★	-
115	P1-M, P2-M	★	★	-	Red Plaid	★	-	★	★	-
121	P1-H, P2-H	★	★	-	Blue	★	★	★	-	★
122	P1-H, P2-H	★	★	-	Green	★	★	★	-	★
123	P1-H, P2-H	★	★	-	Cocoa	★	★	★	-	★
124	P1-H, P2-H	★	★	-	Black and Gray	★	★	★	-	★
125	P1-H, P2-H	★	★	-	Red	★	★	★	-	★
131	P1-M, P2-M	★	★	-	Blue	-	-	★	-	-
132	P1-M, P2-M	★	★	-	Green	-	-	★	-	-
133	P1-M, P2-M	★	★	-	Cocoa	-	-	★	-	-
134	P1-M, P2-M	★	★	-	Gray	-	-	★	-	-
201	P1-L, P2-L	-	★	-	Blue	-	-	★	-	-
203	P1-L, P2-L	-	★	-	Cocoa	-	-	★	-	-
204	P1-L, P2-L	-	★	-	Gray	-	-	★	-	-
211	P1-L, P2-L	-	★	-	Blue	★	-	-	-	-
214	P1-L, P2-L	-	★	-	Gray	★	-	-	-	-
231	P1-M, P2-M	-	★	-	Blue	★	-	-	-	-
234	P1-M, P2-M	-	★	-	Gray	★	-	-	-	-
241	P1-H, P2-H	-	★	-	Blue	★	-	-	-	-
244	P1-H, P2-H	-	★	-	Gray	★	-	-	-	-
245	P1-H, P2-H	-	★	-	Red	★	★	-	-	★
251	P1-H, P2-H	-	★	-	Blue	★	★	-	-	★
253	P1-H, P2-H	-	★	-	Cocoa	★	★	-	-	★
254	P1-H, P2-H	-	★	-	Black	-	-	-	-	★
261	P2-P	-	★	-	Blue	-	-	-	-	★
263	P2-P	-	★	-	Cordovan	-	-	-	-	★
265	P2-P	-	★	-	Red	-	-	-	-	★
294	P1-L, P2-L, P1-M, P2-M	-	★	-	Gray	★	-	-	★	-

★ Indicates use as required.

⊞ Indicates parts not listed in any previous parts book.
May 1, 1962 Supersedes Nov. 30, 1961.

Prices and specifications subject to change without notice.
Right and left part numbers are on same line,
first number is right, second number is left.

* Indicates change or addition.

CODE	REMARKS	PER CAR	SED.	SP. 4 D.	SUB.	SP. CL. CP.	CV. CP.
------	---------	---------	------	----------	------	-------------	---------

NOTE: RIGHT HAND AND LEFT HAND PARTS LISTED ON THE SAME LINE. Whenever right and left hand parts are identified by consecutive part numbers, they will be listed as in the following example:
 PANEL, Door Trim 2083 344-5
 Interpreted, this indicates that Panel, right is Part No. 2083 344 and Panel, left is Part No. 2083 345.

23-71-1	COVER, Front Console P2-P						
	(code 261)	1	----	----	----	E2296 320-1	E2296 320-1
	(code 263)	1	----	----	----	E2296 324-5	E2296 324-5
	(code 265)	1	----	----	----	E2296 328-9	E2296 328-9
23-76-3	ARM REST, Front Door P1, P2						
	(codes 101, 111, 131, 201, 211, 231) (blue)	2	2273 000	----	2273 000	2273 000	
	(codes 103, 113, 133, 203) (cocoa)	2	2273 002	----	2273 002	2273 002	
	(codes 104, 114, 134, 204, 214, 234) (gray)	2	2273 003	----	2273 003	2273 003	
	(codes 112, 132) (green)	2	2273 001	----	2273 001		
	(codes 121, 241, 251) (blue)	1	2273 006-7	2273 006-7	2273 006-7	2273 006-7	2273 006-7
	(code 122) (green)	1	2273 008-9	2273 008-9	2273 008-9	2273 008-9	2273 008-9
	(codes 123, 253) (cocoa)	1	2273 010-11	2273 010-11	2273 010-11	2273 010-11	2273 010-11
	(codes 124, 244, 254) (gray)	1	2273 012-3	2273 012-3	2273 012-3	2273 012-3	2273 012-3
	(codes 115, 125, 545) (red)	1	*2273 014-5	*2273 014-5	*2273 014-5	*2273 014-5	*2273 014-5
	(code 294) (gray)	2	2212 691				
	(code 261) (blue)	1	----	----	----	2249 778-9	2249 778-9
	(code 263) (cordovan)	1	----	----	----	2249 780-1	2249 780-1
(code 265) (black)	1	----	----	----	2297 160-1	2297 160-1	
Screw	4	162 090	162 090	162 090	162 090	162 090	
23-76-16	NUT, Arm Rest to Panel P1, P2	★	1280 134	1280 134	1280 134	1280 134	1280 134
23-76-18	ARM REST, Front Seat Back Center P1, P2						
	(code 245)	1	2293 750	2293 750	----	2293 750	2293 750
	(code 251)	1	2293 893	2293 893	----	2293 893	2293 893
	(code 253)	1	2293 894	2293 894	----	2293 894	2293 894
	(code 254)	1	----	----	----	----	2293 895
23-76-27	HOOK, Front Seat Arm Rest Frame Retainer P1-H, P2-H	1	----	1918 568	----	1918 568	1918 568
23-76-28	BAR, Front Seat Center Arm Rest Frame Lock P1-H, P2-H	1	----	2270 102	----	2270 102	2270 102
23-76-34	COVER, Front Seat Back Center Arm Rest P1, P2						
	(code 245)	1	2293 747	2293 747	----	2293 747	2293 747
	(code 251)	1	2293 890	2293 890	----	2293 890	2293 890
	(code 253)	1	2293 891	2293 891	----	2293 891	2293 891
	(code 254)	1	----	----	----	----	2293 892
	(codes 124, 134, 204, 714, 804, 814) (gray)	1	----	----	2249 857		
23-76-59	ARM REST, Rear Door P1, P2						
	(codes 101, 111, 121, 131, 201, 211, 231, 241, 251) (blue)	2	2273 000	2273 000	2273 000		
	(codes 103, 113, 123, 133, 203, 253) (cocoa)	2	2273 002	2273 002	2273 002		

★ Indicates use as required.
 E Indicates parts not listed in any previous parts book.
 Right and left part numbers are on same line,
 first number is right, second number is left.
 * Indicates change or addition.

1962 PASSENGER CAR PARTS CATALOG

INTERIOR TRIM

CODE	REMARKS	PER CAR	SED.	SP. 4D.	SUB.	SP. CL. CP.	CV. CP.	
23-76-59	ARM REST, Rear Door - Cont'd P1, P2 (codes 104, 114, 124, 134, 204, 214, 234, 244) (gray) (codes 112, 122, 132) (green) (codes 115, 125, 245) (red) (code 294) (gray) (screw)	2 2 2 2 4	2273 003 2273 001 *2273 004 2212 691 162 090	2273 003 2273 001 *2273 004 162 090	2273 003 2273 001 *2273 004 162 090	2273 003 2273 001 *2273 004 162 090		
23-76-66	ARM REST, Rear Quarter P1, P2 (codes 101, 111, 121, 251) (blue) (codes 112, 122) (green) (codes 103, 113, 123, 253) (cocoa) (codes 104, 114, 124) (gray) (codes 115, 125, 245) (red) (code 294) (gray) (code 261) (blue) (code 263) (cordovan) (code 265) (black)	2 2 2 2 2 2 2 2 2	2273 000 2273 001 2273 002 2273 003 *2273 004 2212 691 ---- ---- ----	---- ---- ---- ---- ---- ---- ---- ---- ----	---- ---- ---- ---- ---- ---- ---- ---- ----	2273 000 2273 001 2273 002 2273 003 *2273 004 2249 776 2249 777 2297 159		
23-76-80	NUT, Quarter Arm Rest to Panel P1, P2	4	1280 134	----	----	1280 134		
23-77-3	ASSIST STRAP, Center Pillar P1-L (4 D.)	2	*2274 841					
23-77-17	SPACER, Assist Strap P1-L	2	2292 201					
23-79-3	CARPET, Front Floor P1, P2 (blue) (green) (cordovan) (black)	1 1 1 1	*2273 063 *2273 064 *2273 065 *2273 066	*2273 063 *2273 064 *2273 065 *2273 066	*2273 063 *2273 064 *2273 065 *2273 066	*2273 063 *2273 064 *2273 065 *2273 066	*2273 063 *2273 064 *2273 065 *2273 066	
23-79-33	CARPET, Rear Floor P1, P2 (blue) (green) (cordovan) (black)	1 1 1 1	*2273 076 *2273 077 *2273 078 *2273 079	*2273 076 *2273 077 *2273 078 *2273 079	*2273 076 *2273 077 *2273 078 *2273 079	*2273 076 *2273 077 *2273 078 *2273 079	*2273 076 *2273 077 *2273 078 *2273 079	
	Center Floor Pan Cover (Vinoleum) (blue) (green) (cordovan) (gray)	1 1 1 1	---- ---- ---- ----	---- ---- ---- ----	*2272 406 *2272 407 *2272 408 *2272 409			
	Rear Floor Pan (blue) (green) (cordovan) (gray)	1 1 1 1	---- ---- ---- ----	---- ---- ---- ----	*2272 410 *2272 411 *2272 412 *2272 413			
	Rear Floor Cover Panel (w/2 seater only) (blue) (green) (cordovan) (gray)	1 1 1 1	---- ---- ---- ----	---- ---- ---- ----	*2272 414 *2272 415 2272 416 *2272 417			
	Floor Pan Axle Kickup Front Trim Panel (embossed card- board) (paint as required)	1	----	----	*2249 857			

★ Indicates use as required.

⊘ Indicates parts not listed in any previous parts book.
March 8, 1963 Supersedes May 1, 1962.

Printed in U.S.A.

Prices and specifications subject to change without notice.

Right and left part numbers are on same line,
first number is right, second number is left.

* Indicates change or addition.

1962 PASSENGER CAR PARTS CATALOG

CODE	REMARKS	PER CAR	SED.	SP. 4 D.	SUB.	SP. CL. CP.	CV. CP.	
23-86-19	STRIP, Headlining Retaining							
	P1, P2							
	Front	1	2167 228-9					
	Rear	1	2254 566-7					
	Side Front	1	----	----	2251 806-7			
	Side Rear	1	----	----	2251 446-7			
23-86-24	RETAINER, Roof Inside Finish							
	Panel							
	P1, P2 (No. 1)	1	----	2162 893	2292 162	2162 893		
	(No. 2)	1	----	2162 894	2292 163	2162 894		
	(No. 3)	1	----	2162 895	2292 164	2162 895		
	(No. 4)	1	----	----	2292 165			
23-86-35	MOULDING, Roof Inside Finish							
	Panel							
	P1-M, P2-M (No. 1)	1	----	----	2292 377	2292 373		
	(No. 2)	1	----	----	2292 377	2292 375		
	(No. 3)	1	----	----	2292 377	2292 377		
	(No. 4 thru No. 6)	1	----	----	2292 377			
23-86-36	CAP, Roof Inside Finish							
	Moulding							
	P1, P2	12	----	----	1759 635			
	(side retainer)	1	----	----	2251 808-9			
	23-91-6	PANEL, Cowl Trim						
		P1, P2						
(codes 101, 111, 121, 131, 201, 211, 231, 241, 251) (blue)		1	2272 208-9	2272 208-9	2272 208-9	2272 208-9	2272 208-9	
(codes 103, 113, 123, 133, 203, 253) (cocoa)		1	2272 210-11	2272 210-11	2272 210-11	2272 210-11	2272 210-11	
(codes 104, 114, 124, 134, 204, 214, 234, 244, 254, 294)(gray)		1	2272 212-3	2272 212-3	2272 212-3	2272 212-3	2272 212-3	
(codes 112, 122, 132)(green)		1	2272 214-5	2272 214-5	2272 214-5	2272 214-5	2272 214-5	
(codes 115, 125, 245)(red)		1	*2272 216-7	*2272 216-7	*2272 216-7	*2272 216-7	*2272 216-7	
(code 261) (blue)		1	----	----	----	2249 742-3	2249 742-3	
(code 263) (cordovan)		1	----	----	----	2249 744-5	2249 744-5	
(code 265) (black)		1	----	----	----	2297 154-5	2297 154-5	
(attach. screw and seal)		1	*6023 388	*6023 388	*6023 388	*6023 388	*6023 388	
23-92-5	PANEL, Door Trim							
	P1-L, P2-L,(2 D.)							
	(code 101)	1	2273 094-5					
	(code 103)	1	2273 096-7					
	(code 104)	1	2273 098-9					
	(code 294)	1	2273 482-3					
	P1-L, P2-L,(4 D.)							
	(codes 101, 201, 211) Front	1	2273 110-11	----	2273 110-11			
	Rear	1	2273 116-7	----	2273 116-7			
	(codes 103, 203) Front	1	2273 112-3	----	2273 112-3			
	Rear	1	2273 118-9	----	2273 118-9			
	(codes 104, 204, 214) Front	1	2273 114-5	----	2273 114-5			
	Rear	1	2273 120-1	----	2273 120-1			
	(code 294) Front	1	2273 486-7					
Rear	1	2273 488-9						

★ Indicates use as required.
 □ Indicates parts not listed in any previous parts book.
 May 1, 1962 Supersedes Nov. 30, 1961.

Printed in U.S.A.
 Prices and specifications subject to change without notice.
 Right and left part numbers are on same line,
 first number is right, second number is left.
 * Indicates change or addition.

CODE	REMARKS	PER CAR	SED.	SP. 4 D.	SUB.	SP. CL. CP.	CV. CP.
23-92-5	PANEL, Door Trim - Cont'd P1-M, P2-M (2 D.) (code 111) (code 112) (code 113) (code 114) (code 115)	1 1 1 1 1	2273 126-7 2273 128-9 2273 130-1 2273 132-3 2249 868-9	---- ---- ---- ---- ----	---- ---- ---- ---- ----	2273 146-7 2273 148-9 2273 150-1 2273 152-3 2249 872-3	
	P1-M, P2-M, (4 D.) (codes 111, 131, 231) (codes 112, 132) (codes 113, 133) (codes 114, 134, 234) (code 115)	Front 1 Rear 1 Front 1 Rear 1 Front 1 Rear 1 Front 1 Rear 1 Front 1 Rear 1	2273 166-7 2273 174-5 2273 168-9 2273 176-7 2273 170-1 2273 178-9 2273 172-3 2273 180-1 2249 878-9 2249 880-1	---- ---- ---- ---- ---- ---- ---- ---- ---- ----	2273 166-7 2273 174-5 2273 168-9 2273 176-7 2273 170-1 2273 178-9 2273 172-3 2273 180-1		
	P1-H, P2-H (codes 121, 241, 251) (code 122) (codes 123, 253) (codes 124, 244, 254) (codes 125, 245)	Front 1 Rear 1 Front 1 Rear 1 Front 1 Rear 1 Front 1 Rear 1	2273 226-7 2273 236-7 2273 228-9 2273 238-9 2273 230-1 2273 240-1 2273 232-3 2273 242-3 2273 234-5 2273 244-5	2273 252-3 2273 262-3 2273 254-5 2273 264-5 2273 256-7 2273 266-7 2273 258-9 2273 268-9 2273 260-1 2273 270-1	2273 226-7 2273 236-7 2273 228-9 2273 238-9 2273 230-1 2273 240-1 2273 232-3 2273 242-3 2273 234-5 2273 244-5	2273 188-9 2273 190-1 2273 192-3 2273 194-5 2273 196-7	2273 188-9 2273 192-3 2273 194-5 2273 196-7
	P2-P (code 261) (code 263) (code 265)	1 1 1	---- ---- ----	---- ---- ----	---- ---- ----	2249 720-1 2249 722-3 2249 724-5	2249 720-1 2249 722-3 2249 724-5
23-96-3	PANEL, Luggage Compartment Front Lining P1, P2 (side to quarter) (filler)	1 1	2162 831 2292 876-7	2162 831 ----	---- ----	2162 831 2292 876-7	
23-96-8	COVER, Wheelhouse Inner Panel (paint as required) P1, P2 (side) (2 seat) (3 seat) Rear Extension (3 seat)	1 1 1 1	2274 718-9 ---- ---- ----	2274 718-9 ---- ---- ----	---- 2273 348-9 2273 476-7 2273 358-9	2274 718-9	
	Side Front Side Rear Deck Lid Hinge (vinoleum) (attaching clip) (screw)	1 1 6 6	---- ---- 6001 401 ----	---- ---- 6001 401 ----	---- ---- ---- 6000 348	---- ---- 6001 401	2249 700-1 2274 878-9 2411 668-9 6001 401
23-96-9	CLIP, Retaining	★	*2165 272	*2165 272	----	*2165 272	*2165 272
23-96-41	RETAINER, Wheelhouse and Lower Quarter Trim Cover P1, P2, Upper Edge, Plastic SCREW	10 ★	---- ----	---- ----	2273 453 *6000 348		
23-99-4	COVER, Center Pillar Trim (paint as required) P1-H, P2-H	1	----	2273 422-3			

★ Indicates use as required.
 □ Indicates parts not listed in any previous parts book.
 Right and left part numbers are on same line,
 first number is right, second number is left.
 * Indicates change or addition.

CODE	REMARKS	PER CAR	SED.	SP. 4 D.	SUB.	SP. CL. CP.	CV. CP.
23-99-9	RETAINER, Body Rear Lock Pillar Quarter Trim P1, P2	1	----	----	2162 508-9		
23-101-3	PANEL, Rear Quarter Trim P1-L, P2-L, (2 D.) (code 101) (code 103) (code 104) (code 294) P1-M, P2-M, (2 D.) (code 111) (code 112) (code 113) (code 114) (code 115) (code 294)	1 1 1 1 1 1 1 1 1 1 1	2273 100-1 2273 102-3 2273 104-5 2273 484-5 2273 134-5 2273 136-7 2273 138-9 2273 140-1 *2249 870-1 2273 484-5				
	P1, P2, (4 D.) (codes 101, 111, 121, 211, 231, 241, 251) Upper Lower (codes 103, 113, 123, 253) Upper Lower (codes 104, 114, 124, 214, 234, 244, 294) Upper Lower (code 115) Upper Lower (codes 112, 122) Upper Lower (codes 125, 245) Upper Lower	1 1 1 1 1 1 1 1 1 1 1 1 1 1 1 1 1 1	2411 042-3 2411 052-3 2411 046-7 2411 056-7 2411 048-9 2411 058-9 *2429 196-7 *2429 198-9 2411 044-5 2411 054-5 2411 050-1 2411 060-1	2411 042-3 *2411 052-3 2411 046-7 2411 056-7 2411 048-9 2411 058-9 2411 044-5 2411 054-5 2411 050-1 2411 060-1			
	P1-H, P2-H (codes 121, 251) (code 122) (codes 123, 253) (codes 124, 254) (codes 125, 245) P2-P (code 261) (code 263) (code 265)	1 1 1 1 1 1 1 1 1	----	----	----	2273 198-9 2273 200-1 2273 202-3 2273 204-5 2273 206-7 2249 726-7 2249 728-9 2249 730-1	2273 212-3 2273 214-5 2273 216-7 2273 218-9 2249 736-7 2249 738-9 2249 740-1
23-101-14	COVER, Upper Quarter Front Trim (paint as required) P1, P2	1	----	----	2273 338-9		
23-101-26	STRIP, Quarter Trim Panel Retaining P1, P2, (4 D.)	1	*2252 372-3				
23-102-3	PANEL, Rear Seat Shelf (paint as required) P1, P2 (fastener)	1 ★	2297 038 6000 903	2297 038 6000 903	----	2297 038 6000 903	
23-103-3	PANEL, Visor Trim P1, P2 (codes 101, 111, 121, 211, 231, 241, 251) (blue) (codes 103, 113, 123, 253) (beige)	2 2	2273 282 2273 284				

★ Indicates use as required.

◻ Indicates parts not listed in any previous parts book.
May 1, 1962 Supersedes Nov. 30, 1961.

Prices and specifications subject to change without notice.

Right and left part numbers are on same line,
first number is right, second number is left.

* Indicates change or addition.

CODE	REMARKS	PER CAR	SED.	SP. 4 D.	SUB.	SP. CL. CP.	CV. CP.	
23-103-3	PANEL, Visor Trim - Cont'd P1, P2 (codes 104, 114, 115, 124, 125, 214, 234, 244, 245, 294) (gray) (codes 112, 122) (green) P1, P2, (padded) (white) (codes 111, 112, 113, 114, 121, 122, 123, 124, 125, 131, 132, 133, 134, 201, 203, 204, 245, 251, 253, 261, 263, 265)(white) (codes 245, 265) (red) (codes 251, 261) (blue) (codes 253, 263) (cocoa) (code 254) (gray)	2 2 2 2 2 2 2 2	*2273 285 2273 283 2273 455		2273 455	2273 455	2273 455	
				2273 286	2273 286	2273 286		
				----	----	----	2273 281	
				----	----	----	2273 278	
				----	----	----	2273 279	
				----	----	----	2273 280	
23-103-10	ARM and BRACKET, Visor P1, P2 (except P2-P) P2-P (chrome)	1 1	2162 626-7 ----	2162 626-7 ----	2162 616-7 ----	2162 626-7 2292 894-5	2162 686-7 2162 686-7	
23-103-18	WASHER, Visor Arm Tension P1, P2	2	6000 106	6000 106	6000 106	6000 106	6000 106	
23-103-48	SUPPORT, Visor Inner P1, P2 (3 1/8")	2	2162 628	2162 628	2162 628	2162 628	2162 628	
23-108-4	CUSHION, Front Seat P1-L, P2-L, (2 D.) (code 101) (w/heavy duty spring) (w/airfoam pad) (code 103) (w/heavy duty spring) (w/airfoam pad) (code 104) (w/heavy duty spring) (w/airfoam pad) (code 294)	1 1 1 1 1 1 1 1 1 1	2246 704 2246 707 2293 991 2246 705 2246 708 2293 992 2246 706 2246 709 2293 993 2293 652					
	P1-L, P2-L, (4 D.) (codes 101, 201) (w/heavy duty spring) (w/airfoam pad) (codes 103, 203) (w/heavy duty spring) (w/airfoam pad) (codes 104, 204) (w/heavy duty spring) (w/airfoam pad)	1 1 1 1 1 1 1 1 1	2246 650 2246 686 2411 009 2246 651 2246 687 2411 010 2246 652 2246 688 2411 011	----		2274 287 2274 290 2411 000 2274 288 2274 291 2411 001 2274 289 2274 292 2411 002		
	(code 211) (w/airfoam pad) (code 214) (w/airfoam pad) (code 294) (w/heavy duty spring) (w/airfoam pad)	1 1 1 1 1 1	2293 962 2271 902 2293 963 2271 903 2293 636 2293 637 2293 826					
	P1-M, P2-M, (2 D.) (code 111) (w/heavy duty spring) (code 112) (w/heavy duty spring) (code 113) (w/heavy duty spring) (code 114)	1 1 1 1 1 1	2246 990 2246 994 2246 991 2246 995 2246 992 2246 996 2246 993	----		2246 990 2246 994 2246 991 2246 995 2246 992 2246 996 2246 993		

★ Indicates use as required.
 □ Indicates parts not listed in any previous parts book.
 Right and left part numbers are on same line,
 first number is right, second number is left.
 * Indicates change or addition.

1962 PASSENGER CAR PARTS CATALOG

INTERIOR TRIM

CODE	REMARKS	PER CAR	SED.	SP. 4D.	SUB.	SP. CL. CP.	CV. CP.
23-108-4	CUSHION, Front Seat - Cont'd						
	P1-M, P2-M (2 D.)						
	(code 115)	1	----	----	----	*2429 225	*2429 225
	(w/heavy duty springs)	1	----	----	----	*2429 226	*2429 226
	(w/heavy duty spring)	1	2246 997	----	----	2246 997	
	(code 294)	1	2293 652				
	(w/heavy duty spring)	1	2293 653				
	(w/airfoam pad)	1	2293 819				
	P1-M, P2-M, (4 D.)						
	(codes 111,131)	1	2246 898	----		2246 958	
(w/heavy duty spring)	1	2246 902	----		2246 962		
(codes 112,132)	1	2246 899	----		2246 959		
(w/heavy duty spring)	1	2246 903	----		2246 963		
(codes 113,133)	1	2246 900	----		2246 960		
(w/heavy duty spring)	1	2246 904	----		2246 964		
(codes 114,134)	1	2246 901	----		2246 961		
(w/heavy duty spring)	1	2246 905	----		2246 965		
(code 115)	1	*2429 205					
(w/heavy duty springs)	1	*2429 206					
(code 231)	1	2271 902					
(code 234)	1	2271 903					
(code 294)	1	2293 636					
(w/heavy duty spring)	1	2293 637					
(w/airfoam pad)	1	2293 826					
P1-H, P2-H							
(code 121)	1	2272 876	2272 876	2272 876	2272 876	2272 961	
(w/elec. seat 6 way)	1	2272 881	2272 881	2272 881	2272 881	2272 966	
(code 122)	1	2272 877	2272 877	2272 877	2272 877	2272 962	
(w/elec. seat 6 way)	1	2272 882	2272 882	2272 882	2272 882	2272 967	
(code 123)	1	2272 878	2272 878	2272 878	2272 878	2272 963	
(w/elec. seat 6 way)	1	2272 883	2272 883	2272 883	2272 883	2272 968	
(code 124)	1	2272 879	2272 879	2272 879	2272 879	2272 964	
(w/elec. seat 6 way)	1	2272 884	2272 884	2272 884	2272 884	2272 969	
(code 125)	1	2272 880	2272 880	2272 880	2272 880	2272 965	
(w/elec. seat 6 way)	1	2272 885	2272 885	2272 885	2272 885	2272 970	
(code 241)	1	2271 902					
(code 244)	1	2271 903					
(code 245)	1	2293 742	2293 742	----	----	2293 760	2293 760
(w/elec. seat 6 way)	1	2293 743	2293 743	----	----	2293 761	2293 761
(code 251)	1	2293 861	2293 861	----	----	2293 865	2293 865
(w/elec. seat 6 way)	1	2293 863	2293 863	----	----	2293 868	2293 868
(code 253)	1	2293 862	2293 862	----	----	2293 866	2293 866
(w/elec. seat 6 way)	1	2293 864	2293 864	----	----	2293 869	2293 869
(code 254)	1	----	----	----	----	----	2293 867
(w/elec. seat 6 way)	1	----	----	----	----	----	2293 870
P2-P							
(code 261)	1	----	----	----	----	2411 116-7	2411 116-7
(code 263)	1	----	----	----	----	2411 118-9	2411 118-9
(code 265)	1	----	----	----	----	2411 120-1	2411 120-1
23-108-5	COVER, Front Seat Cushion						
	P1-L, P2-L, (2 D.)						
	(code 101)	1	2246 701				
	(code 103)	1	2246 702				
	(code 104)	1	2246 703				
	(code 294)	1	2293 651				
	P1-L, P2-L, (4 D.)						
	(codes 101,201)	1	2246 647	----		2274 284	
	(codes 103,203)	1	2246 648	----		2274 285	
	(codes 104,204)	1	2246 649	----		2274 286	
	(code 211)	1	2271 900				
	(code 214)	1	2271 901				
	(code 294)	1	2293 635				

★ Indicates use as required.
 Ⓚ Indicates parts not listed in any previous parts book.
 May 1, 1962 Supersedes Nov. 30, 1961.

Prices and specifications subject to change without notice.
 Right and left part numbers are on same line,
 first number is right, second number is left.

* Indicates change or addition.

CODE	REMARKS	PER CAR	SED.	SP. 4 D.	SUB.	SP. CL. CP.	CV. CP.
23-108-5	COVER, Front Seat Cushion-Cont'd P1-M, P2-M, (2 D.)						
	(code 111)	1	2246 986	----	----	2246 986	
	(code 112)	1	2246 987	----	----	2246 987	
	(code 113)	1	2246 988	----	----	2246 988	
	(code 114)	1	2246 989	----	----	2246 989	
	(code 115)	1	*2429 224	----	----	*2429 224	
	(code 294)	1	2293 651				
	P1-M, P2-M, (4 D.)						
	(codes 111, 131)	1	2246 894	----	2246 954		
	(codes 112, 132)	1	2246 895	----	2246 955		
	(codes 113, 133)	1	2246 896	----	2246 956		
	(codes 114, 134)	1	2246 897	----	2246 957		
	(code 115)	1	*2429 204				
	(code 231)	1	2271 900				
	(code 234)	1	2271 901				
	(code 294)	1	2293 635				
	P1-H, P2-H						
	(code 121)	1	2272 871	2272 871	2272 871	2272 956	
	(code 122)	1	2272 872	2272 872	2272 872	2272 957	
	(code 123)	1	2272 873	2272 873	2272 873	2272 958	
	(code 124)	1	2272 874	2272 874	2272 874	2272 959	
	(code 125)	1	2272 875	2272 875	2272 875	2272 960	
	(code 241)	1	2271 900				
	(code 244)	1	2271 901				
	(code 245)	1	2293 740	2293 740	----	2293 740	2293 740
	(code 251)	1	2293 855	2293 855	----	2293 855	2293 855
	(code 253)	1	2293 856	2293 856	----	2293 856	2293 856
	(code 254)	1	----	----	----	----	2293 857
	P2-P						
	(code 261)	2	----	----	----	2411 113	2411 113
	(code 263)	2	----	----	----	2411 114	2411 114
	(code 265)	2	----	----	----	2411 115	2411 115
23-108-12	SEAT, Front (less cushion) P1-L, P2-L, (2 D.)						
	(code 101)	1	2246 716-7				
	(w/heavy duty spring)	1	2246 722-3				
	(w/ash receiver) Right	1	2293 804				
	(w/heavy duty springs and ash receiver)	1	*2414 932				
	(code 103)	1	2246 718-9				
	(w/heavy duty spring)	1	2246 724-5				
	(w/ash receiver) Right	1	2293 805				
	(w/heavy duty springs and ash receiver)	1	*2414 933				
	(code 104)	1	2246 720-1				
	(w/heavy duty spring)	1	2246 726-7				
	(w/ash receiver) Right	1	2293 806				
	(w/heavy duty springs and ash receiver)	1	*2414 934				
	(code 294)	1	2293 656-7				
	(w/heavy duty spring)	1	2293 658-9				
	(w/ash receiver) Right	1	2293 820				
	(w/heavy duty spring and ash receiver)	1	*2414 935				
	P1-L, P2-L, (4 D.)						
	(codes 101, 201)	1	2246 656	----	2274 296		
	(w/heavy duty spring)	1	2246 689	----	2274 299		
	(w/ash receiver)	1	2293 789	----	2293 810		

★ Indicates use as required.

□ Indicates parts not listed in any previous parts book.

Right and left part numbers are on same line, first number is right, second number is left.

* Indicates change or addition.

1962 PASSENGER CAR PARTS CATALOG

INTERIOR TRIM

CODE	REMARKS	PER CAR	SED.	SP. 4D.	SUB.	SP. CL. CP.	CV. CP.
23-108-12	SEAT, Front (less cushion) - Cont'd						
	P1-L, P2-L (4 D.)						
	(codes 103, 203)	1	2246 657	----	2274 297		
	(w/heavy duty spring)	1	2246 690	----	2274 300		
	(w/ash receiver)	1	2293 790	----	2293 811		
	(codes 104, 204)	1	2246 658	----	2274 298		
	(w/heavy duty spring)	1	2246 691	----	2274 301		
	(w/ash receiver)	1	2293 791	----	2293 812		
	P1-L, P2-L, P1-M, P2-M, P1-H, P2-H, (4 D.)						
	(codes 211, 231, 241)	1	2271 906				
	(codes 214, 234, 244)	1	2271 907				
	(code 294)	1	2293 639				
	(w/heavy duty spring)	1	2293 640				
	(w/ash receiver)	1	2293 827				
	P1-M, P2-M, (2 D.)						
	(code 111)	1	2272 781-2	----	----	2272 781-2	
	(w/heavy duty spring)	1	2272 789-90	----	----	2272 789-90	
	(code 112)	1	2272 783-4	----	----	2272 783-4	
	(w/heavy duty spring)	1	2272 791-2	----	----	2272 791-2	
	(code 113)	1	2272 785-6	----	----	2272 785-6	
	(w/heavy duty spring)	1	2272 793-4	----	----		
	(code 114)	1	2272 787-8	----	----	2272 787-8	
	(w/heavy duty spring)	1	2272 795-6	----	----		
	(code 115)	1	*2429 230-1	----	----	*2429 230-1	
	(w/heavy duty springs)	1	*2429 232-3	----	----	*2429 232-3	
	(code 294)	1	2293 656-7				
	(w/heavy duty spring)	1	2293 658-9				
	(w/ash receiver) Right	1	2293 820				
	P1-M, P2-M, (4 D.)						
	(codes 111, 131)	1	2246 914	----	2246 970		
	(w/heavy duty spring)	1	2246 918	----	2246 974		
	(codes 112, 132)	1	2246 915	----	2246 971		
	(w/heavy duty spring)	1	2246 919	----	2246 975		
	(codes 113, 133)	1	2246 916	----	2246 972		
	(w/heavy duty spring)	1	2246 920	----	2246 976		
	(codes 114, 134)	1	2246 917	----	2246 973		
	(w/heavy duty spring)	1	2246 921	----	2246 977		
	(code 115)	1	*2429 209				
	(w/heavy duty springs)	1	*2429 210				
	P1-H, P2-H						
	(code 121)	1	2272 896	2272 896	2272 896	2272 981-2	
	(code 122)	1	2272 897	2272 897	2272 897	2272 983-4	
	(code 123)	1	2272 898	2272 898	2272 898	2272 985-6	
	(code 124)	1	2272 899	2272 899	2272 899	2272 987-8	
	(code 125)	1	2272 900	2272 900	2272 900	2272 989-90	
	(code 245)	1	2293 748-9	2293 748-9	----	2293 762-3	2293 762-3
	(code 251)	1	2293 880-1	2293 880-1	----	2293 884-5	2293 884-5
	(code 253)	1	2293 882-3	2293 882-3	----	2293 886-7	2293 886-7
	(code 254)	1	----	----	----	----	2293 888-9
23-108-15	SPRING and COVER, Front Seat Back						
	P2-P						
	(code 261)	2	----	----	----	*2411 128	*2411 128
	(code 263)	2	----	----	----	*2411 129	*2411 129
	(code 265)	2	----	----	----	*2411 130	*2411 130

★ Indicates use as required.

☐ Indicates parts not listed in any previous parts book.

May 1, 1962 Supersedes Nov. 30, 1961..

Prices and specifications subject to change without notice.

Right and left part numbers are on same line,
first number is right, second number is left.

* Indicates change or addition.

CODE	REMARKS	PER CAR	SED.	SP. 4 D.	SUB.	SP. CL. CP.	CV. CP.
23-108-16	COVER, Front Seat Back P1-L, P2-L, (2 D.) (code 101) (code 103) (code 104) (code 294)	1 1 1 1	2246 710-11 2246 712-3 2246 714-5 2293 654-5				
	P1-L, P2-L, (4 D.) (codes 101, 201) (codes 103, 203) (codes 104, 204) (code 211) (code 214) (code 294)	1 1 1 1 1 1	2246 653 2246 654 2246 655 2271 904 2271 905 2293 638	---- ---- ----		2274 293 2274 294 2274 295	
	P1-M, P2-M, (2 D.) (code 111) (code 112) (code 113) (code 114) (code 115) (code 294)	1 1 1 1 1 1	2272 773-4 2272 775-6 2272 777-8 2272 779-80 2429 228-9 2293 654-5	---- ---- ---- ---- ----		2272 773-4 2272 775-6 2272 777-8 2272 779-80 2429 228-9	
	P1-M, P2-M, (4 D.) (codes 111, 131) (codes 112, 132) (codes 113, 133) (codes 114, 134) (code 115) (code 231) (code 234) (code 294)	1 1 1 1 1 1 1 1	2246 910 2246 911 2246 912 2246 913 2429 208 2271 904 2271 905 2293 638	---- ---- ---- ----		2246 966 2246 967 2246 968 2246 969	
	P1-H, P2-H (code 121) (code 122) (code 123) (code 124) (code 125) (code 241) (code 244) (code 245) (code 251) (code 253) (code 254)	1 1 1 1 1 1 1 1 1 1 1	2272 891 2272 892 2272 893 2272 894 2272 895 2271 904 2271 905 *2293 744-5 2293 874-5 2293 876-7 ----	2272 891 2272 892 2272 893 2272 894 2272 895 2293 744-5 2293 874-5 2293 876-7 ----	2272 891 2272 892 2272 893 2272 894 2272 895 ---- ---- ---- ----	2272 971-2 2272 973-4 2272 975-6 2272 977-8 2272 979-80 2293 744-5 2293 874-5 2293 876-7 ----	2293 744-5 2293 874-5 2293 876-7 2293 878-9
	P2-P (code 261) (code 263) (code 265)	2 2 2	---- ---- ----	---- ---- ----		2411 125 2411 126 2411 127	2411 125 2411 126 2411 127
23-108-32	PANEL, Back of Front Seat Back P2-P (panel and cover) (code 261) (code 263) (code 265)	2 2 2	---- ---- ----	---- ---- ----		2411 134 2411 135 2411 136	2411 134 2411 135 2411 136
23-108-84	COVER, Front Seat Back Outer Hinge Arm P1, P2 (codes 101, 111, 121, 251) (blue) (codes 103, 113, 123, 253) (cocoa)	1 1	2272 476-7 2272 480-1	2272 476-7 2272 480-1	---- ----	2272 476-7 2272 480-1	2272 476-7 2272 480-1

★ Indicates use as required.
 ☐ Indicates parts not listed in any previous parts book.
 Right and left part numbers are on same line,
 first number is right, second number is left.
 * Indicates change or addition.

CODE	REMARKS	PER CAR	SED.	SP. 4 D.	SUB.	SP. CL. CP.	CV. CP.
23-108-84	COVER, Front Seat Back Outer Hinge Arm - Cont'd P1, P2 (codes 104, 114, 125, 254, 294)						
	(gray)	1	2272 482-3	----	----	2272 482-3	2272 482-3
	(codes 112, 122) (green)	1	2272 478-9	----	----	2272 478-9	
	(codes 125, 245) (red)	1	2272 484-5	2272 484-5	----	2272 484-5	2272 484-5
23-108-98	SHIELD, Front Seat Side P2-P (back)	2	----	----	----	*2161 236-7	*2161 236-7
	(cushion)	1	----	----	----	*2292 492-3	*2292 492-3
23-109-3	BACK, Rear Seat P1-L, P2-L, (Sub. 2nd. Seat) (codes 101, 201)	1	2246 668	----	*2414 871		
	(w/heavy duty spring)	1	2246 698				
	(codes 103, 203)	1	2246 669	----	*2414 872		
	(w/heavy duty spring)	1	2246 699				
	(codes 104, 204)	1	2246 670	----	*2414 873		
	(w/heavy duty spring)	1	2246 700				
	(code 211)	1	2271 918				
	(code 214)	1	2271 919				
	P1-M, P2-M, (Sub. 2nd. Seat) (codes 111, 131)	1	2246 946	----	*2414 889	2246 946	
	(w/heavy duty spring)	1	2246 950	----	----	2246 950	
	(codes 112, 132)	1	2246 947	----	*2414 890	2246 947	
	(w/heavy duty spring)	1	2246 951	----	----	2246 951	
	(codes 113, 133)	1	2246 948	----	*2414 891	2246 948	
	(w/heavy duty spring)	1	2246 952	----	----	2246 952	
	(codes 114, 134)	1	2246 949	----	*2414 892	2246 949	
	(w/heavy duty spring)	1	2246 953	----	----	2246 953	
	(code 115)	1	*2429 218	----	----	*2429 218	
	(w/heavy duty springs)	1	*2429 219	----	----	*2429 219	
	(code 231)	1	2271 918				
	(code 234)	1	2271 919				
	(code 294)	1	2293 649				
	(w/heavy duty spring)	1	2293 650				
	P1-M, P2-M, (Sub. 3rd. Seat) (code 131)	1	----	----	2274 207		
	(code 132)	1	----	----	2274 208		
	(code 133)	1	----	----	2274 209		
	(code 134)	1	----	----	2274 210		
	P1-H, P2-H, (Sub. 2nd. Seat) (code 121)	1	2272 946	2272 946	*2414 922	2272 946	
	(code 122)	1	2272 947	2272 947	*2414 923	2272 947	
	(code 123)	1	2272 948	2272 948	*2414 924	2272 948	
	(code 124)	1	2272 949	2272 949	*2414 925	2272 949	
	(code 125)	1	2272 950	2272 950	*2414 926	2272 950	
	(code 241)	1	2271 918				
	(code 244)	1	2271 919				
	(code 245)	1	2293 759	2293 759	----	2293 759	2293 773
	(code 251)	1	2293 918	2293 918	----	2293 918	2293 935
	(code 253)	1	2293 919	2293 919	----	2293 919	2293 936
	(code 254)	1	----	----	----	----	2293 937
	P1-H, P2-H, (Sub. 3rd. Seat) (code 121)	1	----	----	2274 265		
	(code 122)	1	----	----	2274 266		
	(code 123)	1	----	----	2274 267		
	(code 124)	1	----	----	2274 268		
	(code 125)	1	----	----	2274 269		
	P2-P (code 261)	1	----	----	----	2411 173	2411 182
	(code 263)	1	----	----	----	2411 174	2411 183
	(code 265)	1	----	----	----	2411 175	2411 184

★ Indicates use as required.

⊠ Indicates parts not listed in any previous parts book.

May 1, 1962 Supersedes Nov. 30, 1961.

CODE	REMARKS	PER CAR	SED.	SP. 4 D.	SUB.	SP. CL. CP.	CV. CP.
23-109-4	COVER, Rear Seat Back						
	P1-L, P2-L, (Sub. 2nd. Seat)						
	(codes 101, 201)	1	2246 665	----	⊠2414 868		
	(codes 103, 203)	1	2246 666	----	⊠2414 869		
	(codes 104, 204)	1	2246 667	----	2274 316		
	(code 211)	1	2271 916				
	(code 214)	1	2271 917				
	(code 294)	1	2293 648				
	P1-M, P2-M, (Sub. 2nd. Seat)						
	(codes 111, 131)	1	2246 942	----	⊠2414 885	2246 942	
	(codes 112, 132)	1	2246 943	----	⊠2414 886	2246 943	
	(codes 113, 133)	1	2246 944	----	2274 177	2246 944	
(codes 114, 134)	1	2246 945	----	2274 178	2246 945		
(code 115)	1	2429 217	----	----	2429 217		
(code 231)	1	2271 916					
(code 234)	1	2271 917					
(code 294)	1	2293 648					
P1-M, P2-M, (Sub. 3rd. Seat)							
(code 131)	1	----	----	2274 203			
(code 132)	1	----	----	2274 204			
(code 133)	1	----	----	2274 205			
(code 134)	1	----	----	2274 206			
P1-H, P2-H, (Sub. 2nd. Seat)							
(code 121)	1	2272 941	2272 941	2274 230	2272 941		
(code 122)	1	2272 942	2272 942	2274 231	2272 942		
(code 123)	1	2272 943	2272 943	2274 232	2272 943		
(code 124)	1	2272 944	2272 944	2274 233	2272 944		
(code 125)	1	2272 945	2272 945	2274 234	2272 945		
(code 241)	1	2271 916					
(code 244)	1	2271 917					
(code 245)	1	2293 757	2293 757	----	2293 757	2293 772	
(code 251)	1	2293 914	2293 914	----	2293 914	2293 932	
(code 253)	1	2293 915	2293 915	----	2293 915	2293 933	
(code 254)	1	----	----	----	----	2293 934	
P1-H, P2-H, (Sub. 3rd. Seat)							
(code 121)	1	----	----	2274 260			
(code 122)	1	----	----	2274 261			
(code 123)	1	----	----	2274 262			
(code 124)	1	----	----	2274 263			
(code 125)	1	----	----	2274 264			
P2-P							
(code 261)	1	----	----	----	2411 170	2411 179	
(code 263)	1	----	----	----	2411 171	2411 180	
(code 265)	1	----	----	----	2411 172	2411 181	
23-109-5	COVER, Rear Seat Back Rear Panel						
	P1, P2, (Sub. 2nd. Seat)						
	(codes 121, 131, 201) (blue)	1	----	----	2272 394		
	(codes 122, 132) (green)	1	----	----	2272 395		
	(codes 123, 133, 203) (cocoa)	1	----	----	2272 396		
	(codes 124, 125, 134, 204) (gray)	1	----	----	2272 397		
	P1, P2, (Sub. 3rd. Seat)						
	(codes 121, 131) (blue)	1	----	----	2272 398		
	(codes 122, 132) (green)	1	----	----	2272 399		
	(codes 123, 133) (cordovan)	1	----	----	2272 400		
(codes 124, 125, 134) (gray)	1	----	----	2272 401			

★ Indicates use as required.

⊠ Indicates parts not listed in any previous parts book.

Right and left part numbers are on same line, first number is right, second number is left.

* Indicates change or addition.

1962 PASSENGER CAR PARTS CATALOG

CODE	REMARKS	PER CAR	SED.	SP. 4 D.	SUB.	SP. CL. CP.	CV. CP.
23-109-5	COVER, Rear Seat Back Rear Panel - Cont'd						
	P1-H, P2-H, (Sub. 2nd. Seat)						
	(code 121) (blue)	1	----	----	2272 394		
	(code 122) (green)	1	----	----	2272 395		
	(code 123) (cordovan)	1	----	----	2272 396		
	(code 124) (gray)	1	----	----	2272 397		
	(code 125) (gray)	1	----	----	2272 397		
	P1, P2 (Sub. 3rd. Seat)						
	(back support panel)						
	(codes 121,131) (blue)	1	----	----	2272 402		
	(codes 122,132) (green)	1	----	----	2272 403		
	(codes 123,133) (cordovan)	1	----	----	2272 404		
	(codes 124,125,134) (gray)	1	----	----	2272 405		
	(codes 261,263,265)	1	----	----	----	----	2249 775
23-109-35	CUSHION, Rear Seat						
	P1-L, P2-L, (Sub. 2nd. Seat)						
	(codes 101,201)	1	2246 662	----	2274 311		
	(w/heavy duty spring)	1	2246 695				
	(w/heavy duty spring and airfoam pad)	1	2293 798				
	(codes 103,203)	1	2246 663	----	2274 312		
	(w/heavy duty spring)	1	2246 696				
	(w/heavy duty spring and airfoam pad)	1	2293 799				
	(codes 104,204)	1	2246 664	----	2274 313		
	(w/heavy duty spring)	1	2246 697				
	(w/heavy duty spring and airfoam pad)	1	2293 800	----	----	2293 800	
	P1-M, P2-M, (Sub. 2nd. Seat)						
	(codes 111,131)	1	2246 934	----	*2414 881	2246 934	
	(w/heavy duty spring)	1	*2246 938	----	----	*2246 938	
	(w/heavy duty spring and airfoam pad)	1	2293 785			2293 785	
	(codes 112,132)	1	2246 935	----	*2414 882	2246 935	
	(w/heavy duty spring)	1	2246 939	----	----	*2246 939	
	(w/heavy duty spring and airfoam pad)	1	2293 786	----	----	2293 786	
	(codes 113,133)	1	2246 936	----	*2414 883	2246 936	
	(w/heavy duty spring)	1	2246 940	----	----	*2246 940	
	(w/heavy duty spring and airfoam pad)	1	2293 787			2293 787	
	(codes 114,134)	1	2246 937	----	*2414 884	2246 937	
	(w/heavy duty spring)	1	2246 941	----	----	*2246 941	
	(w/heavy duty spring and airfoam pad)	1	2293 788			2293 788	
	(code 115)	1	*2429 214	----	----	*2429 214	
	(w/heavy duty spring and airfoam pad)	1	*2429 216	----	----	*2429 216	
	P1-L, P2-L, P1-M, P2-M, P1-H, P2-H						
	(codes 211,231,241)	1	2271 912				
	(codes 214,234,244)	1	2271 913				
	(code 241) (w/airfoam pad)	1	2271 914				
	(code 244) (w/airfoam pad)	1	2271 915				
	(code 294)	1	2293 645				
	(w/heavy duty spring)	1	2293 646				
	(w/heavy duty spring and airfoam pad)	1	2293 647				

★ Indicates use as required.

⊠ Indicates parts not listed in any previous parts book.
May 1, 1962 Supersedes Nov. 30, 1961.

Prices and specifications subject to change without notice.
Right and left part numbers are on same line,
first number is right, second number is left.

* Indicates change or addition.

CODE	REMARKS	PER CAR	SED.	SP. 4 D.	SUB.	SP. CL. CP.	CV. CP.
23-109-35	CUSHION, Rear Seat - Cont'd						
	P1-M, P2-M, (Sub. 3rd. Seat)						
	(code 131)	1	----	----	2274 195		
	(code 132)	1	----	----	2274 196		
	(code 133)	1	----	----	2274 197		
	(code 134)	1	----	----	2274 198		
	P1-H, P2-H, (Sub. 2nd. Seat)						
	(code 121)	1	2272 926	2272 926	2414 907	2272 926	
	(w/airfoam pad)	1	2272 931	2272 931	----	2272 931	
	(code 122)	1	2272 927	2272 927	2414 908	2272 927	
	(w/airfoam pad)	1	2272 932	2272 932	----	2272 932	
	(code 123)	1	2272 928	2272 928	2414 909	2272 928	
	(w/airfoam pad)	1	2272 933	2272 933	----	2272 933	
	(code 124)	1	2272 929	2272 929	2414 910	2272 929	
	(w/airfoam pad)	1	2272 934	2272 934	----	2272 934	
	(code 125)	1	2272 930	2272 930	2414 911	2272 930	
	(w/airfoam pad)	1	2272 935	2272 935	----	2272 935	
	(code 245)	1	2293 755	2293 755	----	2293 755	2293 768
	(w/airfoam pad)	1	2293 756	2293 756	----	2293 756	2293 769
	(code 251)	1	2293 910	2293 910	----	2293 910	2293 926
	(w/airfoam pad)	1	2293 912	2293 912	----	2293 912	2293 929
	(code 253)	1	2293 911	2293 911	----	2293 911	2293 927
	(w/airfoam pad)	1	2293 913	2293 913	----	2293 913	2293 930
	(code 254)	1	----	----	----	----	2293 928
	(w/airfoam pad)	1	----	----	----	----	2293 931
	P1-H, P2-H, (Sub. 3rd. Seat)						
	(code 121)	1	----	----	2274 250		
	(code 122)	1	----	----	2274 251		
	(code 123)	1	----	----	2274 252		
	(code 124)	1	----	----	2274 253		
	(code 125)	1	----	----	2274 254		
	P2-P						
	(code 261)	1	----	----	----	2411 155	2411 164
	(code 263)	1	----	----	----	2411 156	2411 165
	(code 265)	1	----	----	----	2411 157	2411 166
23-109-36	COVER, Rear Seat Cushion						
	P1-L, P2-L, (Sub. 2nd. Seat)						
	(codes 101, 201)	1	2246 659	----	*2274 308		
	(codes 103, 203)	1	2246 660	----	*2274 309		
	(codes 104, 204)	1	2246 661	----	*2274 310		
	(code 211)	1	2271 910				
	(code 294)	1	2293 644				
	P1-M, P2-M, (Sub. 2nd. Seat)						
	(codes 111, 131)	1	2246 930	----	2274 167	2246 930	
	(codes 112, 132)	1	2246 931	----	2274 168	2246 931	
	(codes 113, 133)	1	2246 932	----	2274 169	2246 932	
	(codes 114, 134)	1	2246 933	----	2274 170	2246 933	
	(code 115)	1	2429 213	----	----	2429 213	
	(code 231)	1	2271 910				
	(code 234)	1	2271 911				
	(code 294)	1	2293 644				
	P1-M, P2-M, (Sub. 3rd. Seat)						
	(code 131)	1	----	----	2274 191		
	(code 132)	1	----	----	2274 192		
	(code 133)	1	----	----	2274 193		
	(code 134)	1	----	----	2274 194		

★ Indicates use as required.

⊔ Indicates parts not listed in any previous parts book. Right and left part numbers are on same line, first number is right, second number is left.

* Indicates change or addition.

1962 PASSENGER CAR PARTS CATALOG

INTERIOR TRIM

CODE	REMARKS	PER CAR	SED.	SP. 4 D.	SUB.	SP. CL. CP.	CV. CP.
23-109-36	COVER, Rear Seat Cushion-Cont'd P1-H, P2-H, (Sub. 2nd. Seat)						
	(code 121)	1	2272 921	2272 921	2274 215	2272 921	
	(code 122)	1	2272 922	2272 922	2274 216	2272 922	
	(code 123)	1	2272 923	2272 923	2274 217	2272 923	
	(code 124)	1	2272 924	2272 924	2274 218	2272 924	
	(code 125)	1	2272 925	2272 925	2274 219	2272 925	
	(code 241)	1	2271 910				
	(code 244)	1	2271 911				
	(code 245)	1	2293 753	2293 753	----	2293 753	2293 766
	(code 251)	1	2293 906	2293 906	----	2293 906	2293 920
	(code 253)	1	2293 907	2293 907	----	2293 907	2293 921
	(code 254)	1	----	----	----	----	2293 922
	P1-H, P2-H, (Sub. 3rd. Seat)						
	(code 121)	1	----	----	2274 245		
	(code 122)	1	----	----	2274 246		
	(code 123)	1	----	----	2274 247		
	(code 124)	1	----	----	2274 248		
	(code 125)	1	----	----	2274 249		
	P2-P						
	(code 261)	1	----	----	----	2411 152	2411 161
	(code 263)	1	----	----	----	2411 153	2411 162
	(code 265)	1	----	----	----	2411 154	2411 163
23-109-38	RETAINER, Rear Seat Cushion P1, P2	2	1810 037	1810 037	1810 037	1810 037	1810 037
	RETAINER, Rear Floor Pan, 3rd. Seat, Front	2	----	----	2251 674		
	P1, P2 Rear	2	----	----	*2422 981		
	CATCH, 3rd. Seat Cushion P1, P2	2	----	----	*2270 834		
23-111-37	STRIP, Folding Top Bow Tacking P2-H (No. 1 and No. 2)	1	----	----	----	----	1950 509
	(No. 3)	1	----	----	----	----	2251 165
23-112-12	BOOT, Folding Top Dust P2-H						
	(code 245) (red)	1	----	----	----	----	2293 707
	(code 251) (blue)	1	----	----	----	----	2293 703
	(code 253) (cocoa)	1	----	----	----	----	2293 705
	(code 254) (gray)	1	----	----	----	----	2293 706
	P2-P						
	(code 261) (blue)	1	----	----	----	----	2411 185
	(code 263) (cocoa)	1	----	----	----	----	2411 186
	(code 265) (black)	1	----	----	----	----	*2411 187
23-112-18	RETAINER, Channel Rear Seat Back Dust Boot P2	1	----	----	----	----	*2270 167
23-112-19	INSERT, Rear Seat Back Dust Boot Cover P2 (vinyl)	1	----	----	----	----	*2160 328
23-112-21	PLATE and FASTENER, Front Seat Center Cushion Flap P2-H	*	----	----	----	----	2193 035
23-112-45	CURTAIN, Folding Top P2 (black)	1	----	----	----	----	*2293 720
	(white)	1	----	----	----	----	2293 721
23-112-46	ZIPPER, Folding Top Curtain P2 (black)	1	----	----	----	----	*2273 435

★ Indicates use as required.

□ Indicates parts not listed in any previous parts book.
March 8, 1963 Supersedes May 1, 1962.

Page IT-42

Printed in U.S.A.

Prices and specifications subject to change without notice.
Right and left part numbers are on same line,
first number is right, second number is left.

* Indicates change or addition.

CODE	REMARKS	PER CAR	SED.	SP. 4 D.	SUB.	SP. CL. CP.	CV. CP.
23-112-70	RETAINER, Folding Top Belt Bar						
	P2 (center)	1	----	----	----	----	*2189 748
	(side)	1	----	----	----	----	2189 852-3
	Top Trim, Inner (5/8" x 8")	2	----	----	----	----	2252 610
23-112-75	END, Folding Top Wire on Binding						
	P2-H	1	----	----	----	----	1158 976-7
23-112-88	CABLE, Folding Top Rear Bow Tension						
	P2-H	2	----	----	----	----	2166 660
23-112-108	TOP DECK and SIDE QUARTER						
	P2-H (black)	1	----	----	----	----	2293 722
	(white)	1	----	----	----	----	2293 723
23-112-112	PAD, Folding Top Side Quarter Stay						
	P2-H (black)	1	----	----	----	----	2293 724-5
23-112-153	PANEL or COVER, Folding Top Well Pocket						
	P1-H, P2-H, (panel and cover)						
	(code 245)	1	----	----	----	----	2293 700-1
	(code 251)	1	----	----	----	----	2293 692-3
	(code 253)	1	----	----	----	----	2293 696-7
	(code 254)	1	----	----	----	----	2293 698-9
	P1-H, P2-H, (cover)						
	(code 245)	1	----	----	----	----	2293 690-1
	(code 251)	1	----	----	----	----	2293 682-3
	(code 253)	1	----	----	----	----	2293 686-7
	(code 254)	1	----	----	----	----	2293 688-9
P2-P (panel and cover)							
(code 261)	1	----	----	----	----	2411 068-9	
(code 263)	1	----	----	----	----	2411 070-1	
(code 265)	1	----	----	----	----	2411 072-3	
P2-P (cover)							
(code 261)	1	----	----	----	----	2411 062-3	
(code 263)	1	----	----	----	----	2411 064-5	
(code 265)	1	----	----	----	----	2411 066-7	
P1, Well Lining Panel	1	----	----	----	----	2293 713	
P1, Quarter Pocket Panel							
Shelf Trim	1	----	----	----	----	*2413 836-7	
23-113-45	WEATHERCORD, Quarter Window Opening						
	P1, P2, (2 D.)						
	(codes 101, 111) (blue)	1	2249 692-3				
	(codes 103, 113) (cocoa)	1	2249 696-7				
	(codes 104, 114, 294) (gray)	1	2249 698-9				
	(code 112) (green)	1	2249 694-5				
	(code 115) (red)	1	2249 866-7				
(flange cover)	★	2292 592	2292 592	----	2292 592	2292 592	
23-113-84	WELT, Folding Top Header						
	P2-H, P2-P (black)	1	----	----	----	----	*2432 150
23-114-2	MATERIAL, Seat Cloth Trim						
	P1-L, P2-L						
	(code 101) (blue)	★	2185 312				
	(code 103) (cocoa)	★	2185 313				
(code 104) (gray)	★	2185 314					

★ Indicates use as required.

⊠ Indicates parts not listed in any previous parts book.

Right and left part numbers are on same line, first number is right, second number is left.

* Indicates change or addition.

CODE	REMARKS	PER CAR	SED.	SP. 4 D.	SUB.	SP. CL. CP.	CV. CP.
23-114-15	MATERIAL, Leather (Imitation) - Cont'd P1, P2 (codes 104, 114, 124, 134, 204, 214, 234, 244, 254)						
	(37-CX-22) (50")(902 gray)	★	2185 119				
	(31-DC-63) (56")(1508-1 gray)	★	2185 279	----	2185 279		
	(28A-AM-22)(50") (codes 114, 134) (1220-1 black)	★	1875 018	----	1875 018	1875 018	
	(28-AM-68) (50")(1546 black)	★	2185 587	2185 587	----	2185 587	2185 587
	(28A-AM-22)(50") (codes 214, 234, 244) (1511 gray)	★	2185 154				
	(28-AM-22) (50")(1508-1 gray)	★	2185 143	2185 143	2185 143	2185 143	2185 143
	(21-CZ-22) (58")(1508-1 gray)	★	2185 146	----	2185 146		
	(19A-C-22) (54")(1220-1 black)	★	1874 975	----	----	----	1874 975
	(19B-C-22) (54")(1220-1 black)	★	1874 975				
	(19-C-22) (54") (codes 114, 134) (1220-1 black)	★	1874 975	----	1874 975	1874 975	
	(19-C-22) (54") (codes 104, 124, 214, 234, 244, 254) (1508-1 gray)	★	2185 149	2185 149	2185 149	2185 149	2185 149
	(19-DJ-22) (54")(1508-1 gray) P1, P2 (codes 112, 122, 132)	★	2185 598	2185 598	2185 598	2185 598	2185 598
	(28A-AM-22)(50")(1507-1 green)	★	2185 159	----	2185 159	2185 159	
	(28-AM-22) (50")(1506-1 green)	★	2185 163	2185 163	2185 163	2185 163	
	(21-CM-22) (54")(1507-1 green)	★	2185 611	----	----	2185 611	
	(19A-C-22) (54")(1506-1 green)	★	2185 167				
	(19-C-22) (54") (codes 112, 132) (1507-1 green)	★	2185 165	----	2185 165	2185 165	
	(19-C-22) (54") (code 122) (1506-1 green)	★	2185 167	2185 167	2185 167	2185 167	
	(19-DJ-22) (54")(1506-1 green)	★	2185 579	2185 579	2185 579	2185 579	
	P1, P2 (codes 115, 125, 245)						
	(28A-AM-22)(50")(1509 red)	★	*2185 150				
	(28A-AM-68)(50")(1509 red)	★	2185 522	2185 522	----	2185 522	2185 522
	(28-AM-22) (50")(1509 red)	★	2185 150	2185 150	2185 150	2185 150	2185 150
	(19A-C-22) (54")(1220-1 black)	★	1874 975				
	(19B-C-22) (54")(1509 red)	★	2185 151				
	(19-C-22) (54")(1509 red)	★	2185 151	2185 151	2185 151	2185 151	2185 151
	(19-DJ-22) (54")(1509 red)	★	2185 545	2185 545	2185 545	2185 545	2185 545
	P1, P2 (code 294)						
	(37-CX-22) (50")(902 gray)	★	2185 119				
	(19A-C-22) (54")(1508-1 gray)	★	2185 149				
	(19-C-22) (54")(902 gray)	★	2185 001				
	(19-DJ-22) (54")(902 gray)	★	2185 599				
	P2-P (code 261)						
	(28A-AM-22)(50") (1501-1 blue)	★	----	----	----	2185 141	2185 141
	(28-AM-22) (50")(1502-1 blue)	★	----	----	----	2185 158	2185 158
	(19A-C-22) (54")(1220-1 black)	★	----	----	----	1874 975	1874 975
	(19A-DJ-22) (54")(1501-1 blue)	★	----	----	----	2185 578	2185 578
	(19B-C-22) (54") (1501-1 blue)	★	----	----	----	2185 147	2185 147
	(19-C-22) (54") (1502-1 blue)	★	----	----	----	2185 164	2185 164
	P2-P (code 263)						
	(28A-AM-22)(50") (1504-1 cocoa)	★	----	----	----	2185 142	2185 142
	(28-AM-22) (50") (1505-1 cordovan)	★	----	----	----	2185 160	2185 160
	(19A-C-22) (54")(1220-1 black)	★	----	----	----	1874 975	1874 975

★ Indicates use as required.
 □ Indicates parts not listed in any previous parts book.
 Right and left part numbers are on same line,
 first number is right, second number is left.
 * Indicates change or addition.

