

1962 CHRYSLER 1962 IMPERIAL

INTERIOR TRIM

HOW TO USE INTERIOR TRIM ILLUSTRATIONS

The illustrations in this section are actual and each body style showing the Interior Trim is included.

The letters shown on the illustration indicate the description of the part and the part type code when referred to the legend which appears preceding the listing of the parts. The letters are consistent throughout the illustrations as "A" is always a Door Trim Panel, Code 23-92-5.

The numbers on the illustration indicate the distribution of material and type of material used. The numbers may vary with each illustration. The legend appears on the illustration.

For complete information on "How to Order" Trim Parts, see Mopar Parts Price List.

1962 CHRYSLER - S SERIES

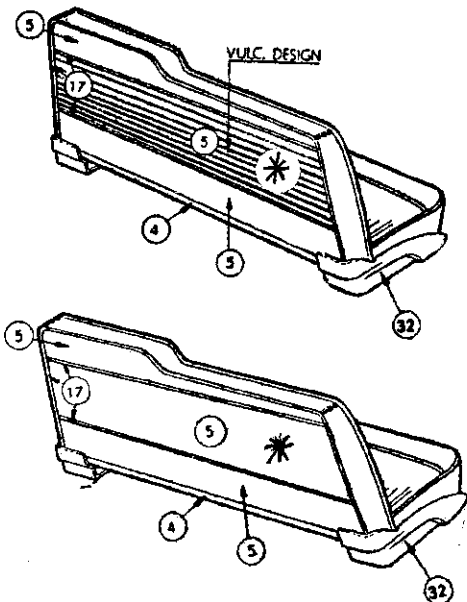
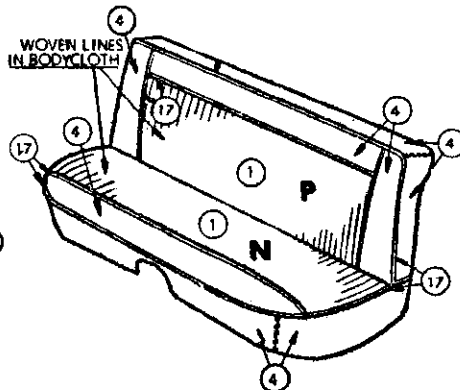
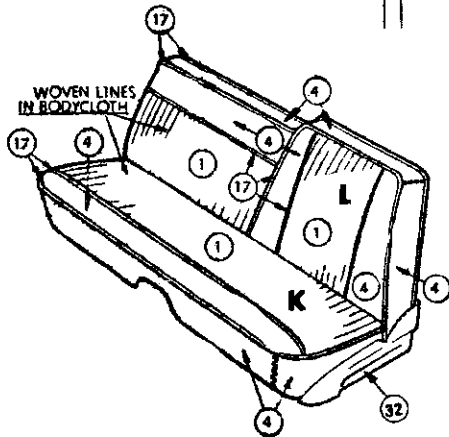
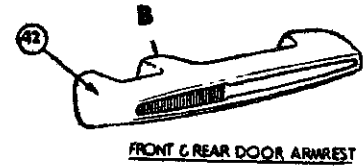
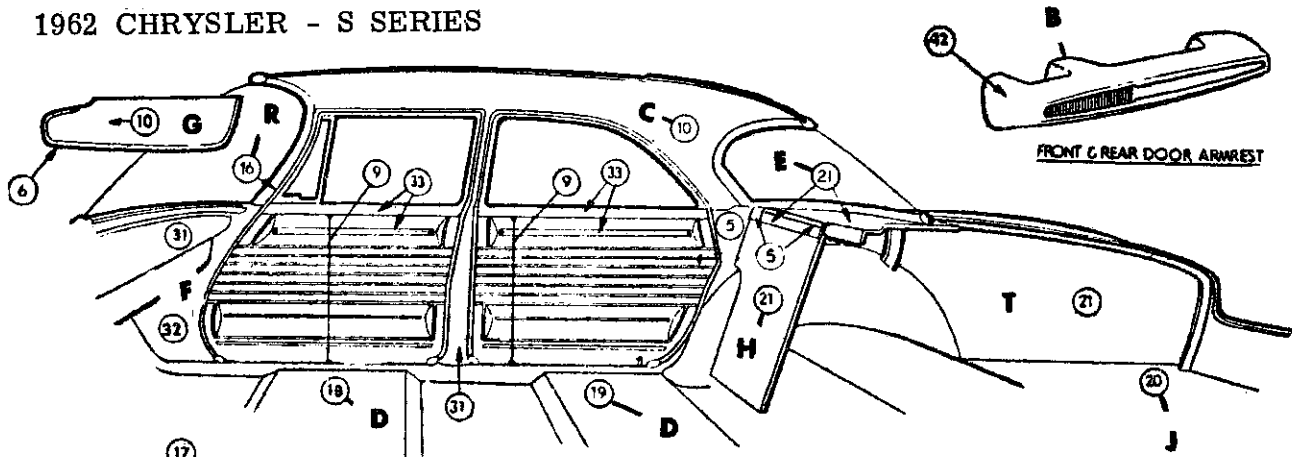

DISTRIBUTION OF MATERIAL

1	BODY CLOTH	1
4	IMITATION LEATHER	28-AM-22
5	IMITATION LEATHER	19-C-22
6	IMITATION LEATHER	19A-C-22
9	IMITATION LEATHER	012-L-22
10	IMITATION LEATHER	12-Y-70
16	LACE	
17	EXTRUDEL VINYL	
18	FLOOR COVERING-FRONT-RUBBER	
19	FLOOR COVERING-REAR-RUBBER	
20	FLOOR COVERING-LUGG. COMPT. RUBBER	
21	EMBOSSED CARDBOARD	
30	PLASTIC	
31	PAINT	
32	METAL	
33	MOULDING	
35	POLYETHYLENE	
36	MYLAR	
38	MOULDED RESIN	
39	CARPET	
41	MOULDED VINYL	
42	PLASTISOL	

* Early Type w/Insert
Late Type w/o Insert

Distribution Drawing Legend Page Appears Following Illustration Section

Codes 301, 303, 304, 305

SCL-411

1962 CHRYSLER SC1-L 4 DOOR SEDAN
CLOTH & IMITATION LEATHER TRIM

1962 CHRYSLER - S SERIES

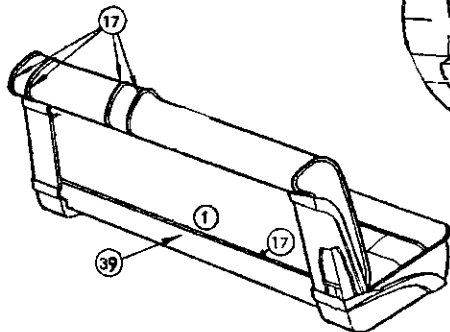
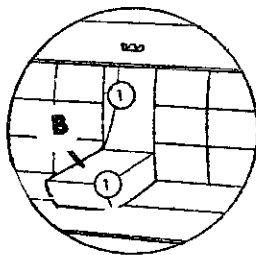
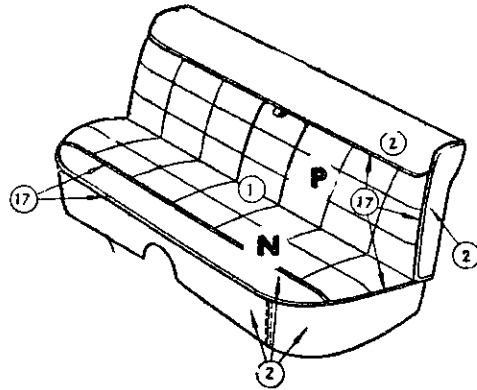
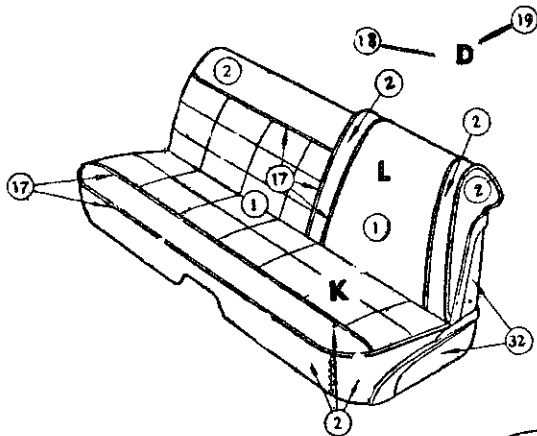
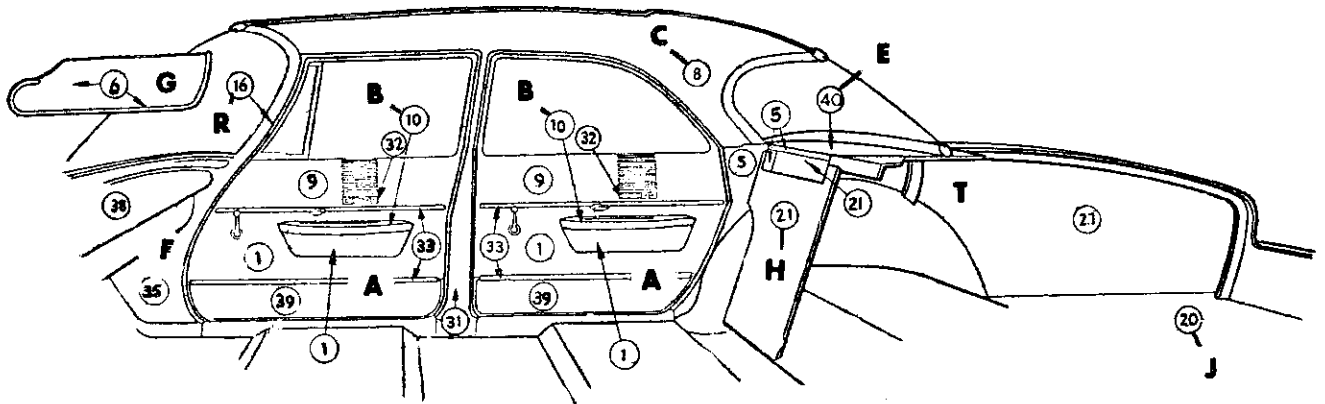

DISTRIBUTION OF MATERIAL

- 1 BODY CLOTH 1
- 2 BODY CLOTH 2
- 3 HEADLINING
- 5 IMITATION LEATHER 19-C-22
- 6 IMITATION LEATHER 19A-C-22
- 7 IMITATION LEATHER 19B-C-22
- 8 IMITATION LEATHER 18-T-16
- 9 IMITATION LEATHER 22-AR-22
- 10 IMITATION LEATHER 28-AM-22
- 17 EXTRUDED VINYL
- 18 FLOOR COVERING-FRONT-CARPET
- 19 FLOOR COVERING-REAR-CARPET
- 20 FLOOR COVERING-LUGG. COMPT. CARPET
- 21 EMBOSSED CARDBOARD
- 30 PLASTIC
- 31 PAINT
- 32 METAL
- 33 MOULDING
- 35 POLYETHYLENE
- 36 MYLAR
- 38 MOULDED RESIN
- 39 CARPET
- 40 WOVEN PAPER

Distribution Drawing Legend Page Appears Following Illustration Section

Codes 321, 323, 324

SCH-412

1962 CHRYSLER SC3-H 4 DOOR SEDAN
CLOTH TRIM

1962 CHRYSLER - S SERIES

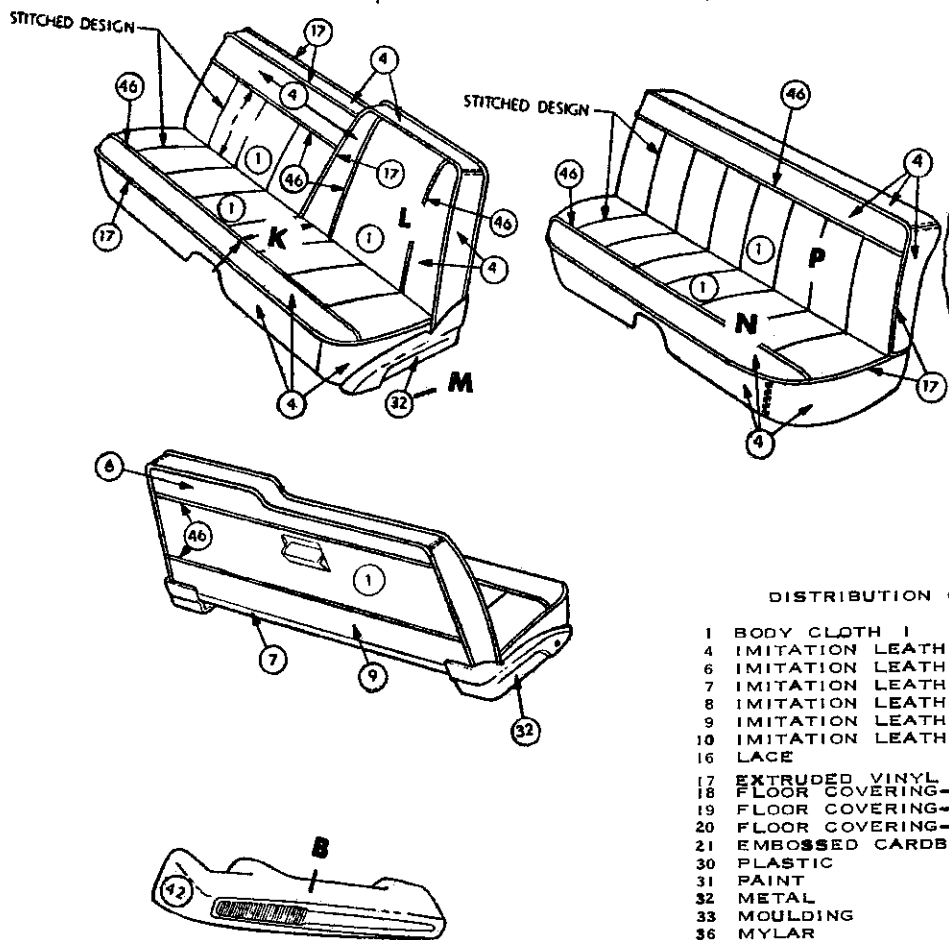
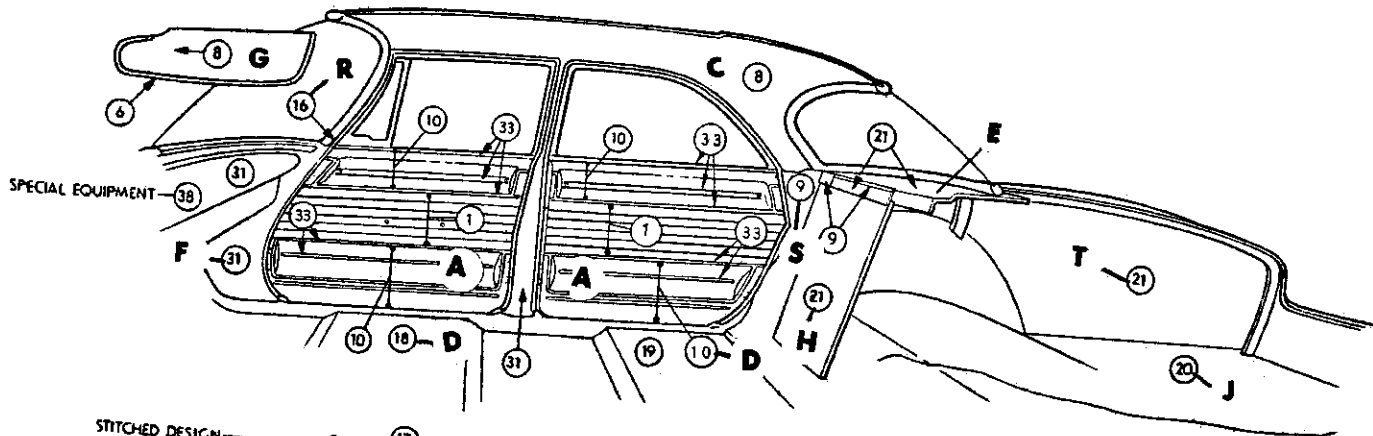

DISTRIBUTION OF MATERIAL

- 1 BODY CLOTH 1
- 4 IMITATION LEATHER 28-AM-22
- 6 IMITATION LEATHER 19-C-22
- 7 IMITATION LEATHER 28A-AM-22
- 8 IMITATION LEATHER 17-C-81
- 9 IMITATION LEATHER 19A-C-22
- 10 IMITATION LEATHER .012-L-22
- 16 LACE
- 17 EXTRUDED VINYL
- 18 FLOOR COVERING-FRONT-CARPET
- 19 FLOOR COVERING-REAR-CARPET
- 20 FLOOR COVERING-LUGG. COMPT. RUBBER
- 21 EMBOSSSED CARDBOARD
- 30 PLASTIC
- 31 PAINT
- 32 METAL
- 33 MOULDING
- 36 MYLAR
- 38 MOULDED RESIN
- 39 CARPET
- 42 PLASTISOL
- 46 EXTRUDED VINYL NO.2

Distribution Drawing Legend Page Appears Following Illustration Section

Codes 302, 308

SCL-411A

1962 CHRYSLER SC1-L 4 DOOR SEDAN
CLOTH & IMITATION LEATHER TRIM

1962 CHRYSLER - S SERIES

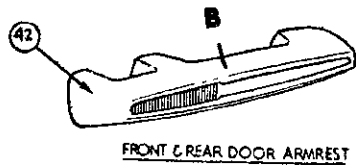
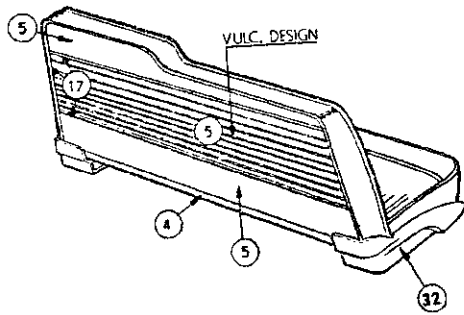
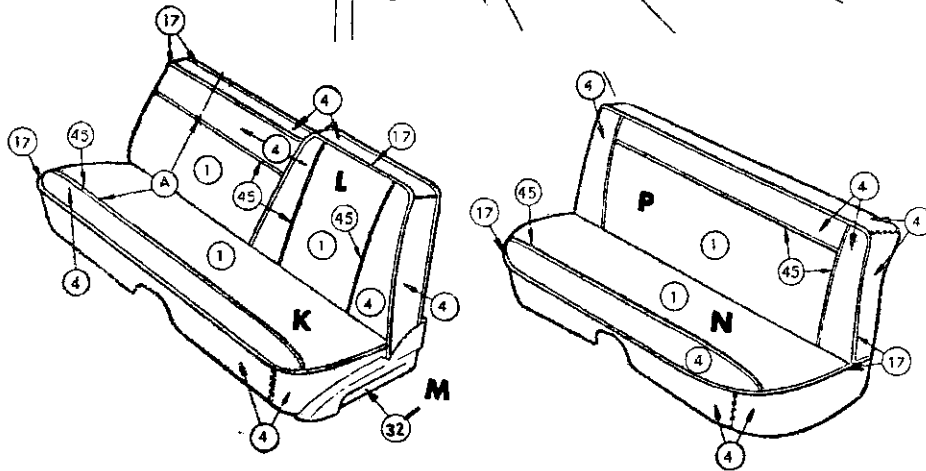
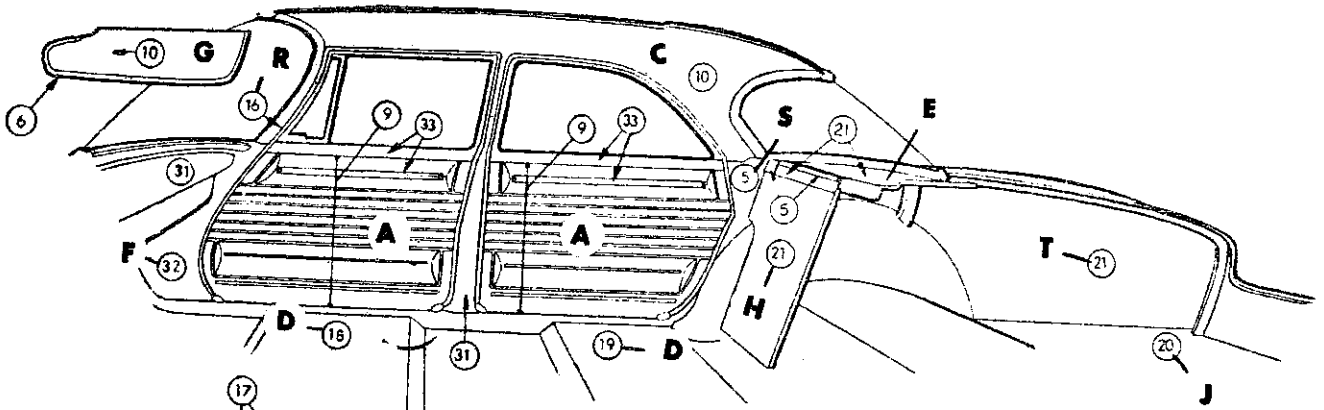

DISTRIBUTION OF MATERIAL

- 1 BODY CLOTH 1
- 4 IMITATION LEATHER 28-AM-22
- 5 IMITATION LEATHER 19-C-22
- 6 IMITATION LEATHER 19A-C-22
- 9 IMITATION LEATHER .012-L-22
- 10 IMITATION LEATHER 12-Y-70
- 16 LACE
- 17 EXTRUDED VINYL
- 18 FLOOR COVERING-FRONT-RUBBER
- 19 FLOOR COVERING-REAR-RUBBER
- 20 FLOOR COVERING-LUGG. COMPT. -RUBBER
- 21 EMBOSSED CARDBOARD
- 30 PLASTIC
- 31 PAINT
- 32 METAL
- 33 MOULDING
- 35 POLYETHYLENE
- 36 MYLAR
- 38 MOULDED RESIN
- 39 CARPET
- 41 MOULDED VINYL
- 42 PLASTISOL
- 45 MYLAR WELT

Distribution Drawing Legend Page Appears Following Illustration Section

Codes 341, 343, 344, 345

SCL-411B

1962 CHRYSLER SC1-L 4 DOOR SEDAN
CLOTH & IMITATION LEATHER TRIM

1962 CHRYSLER - S SERIES

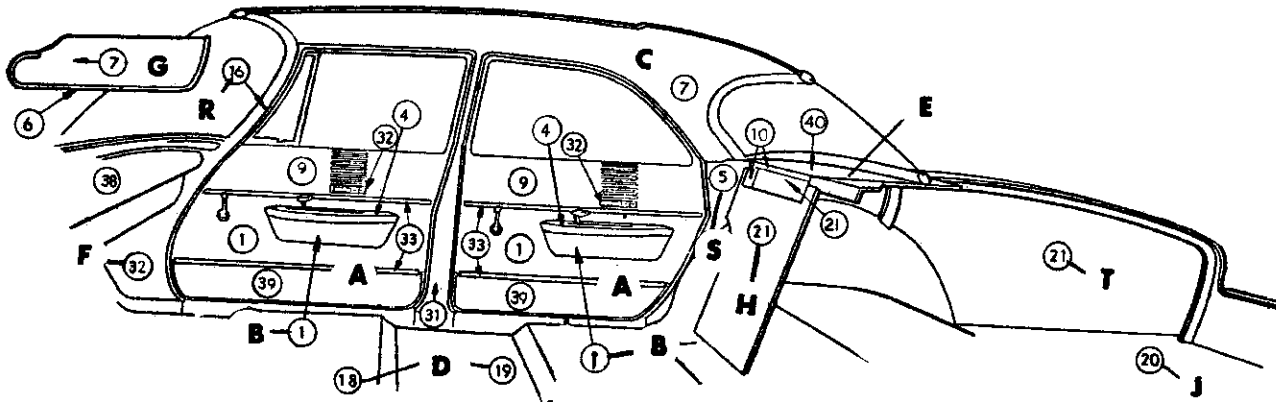

STITCHED DESIGN

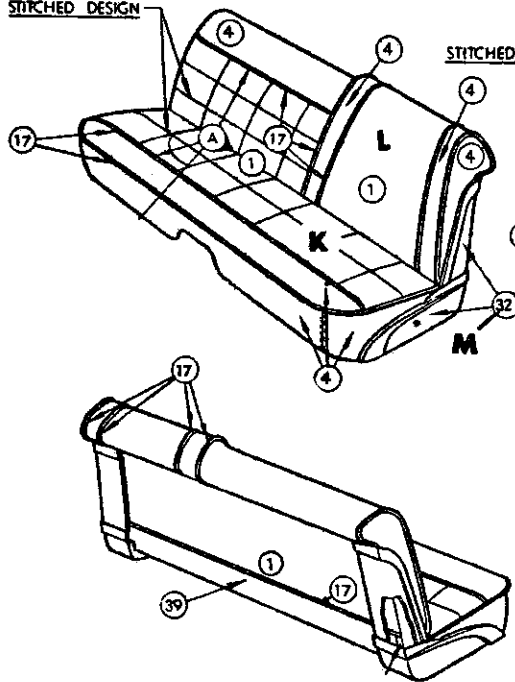

STITCHED DESIGN

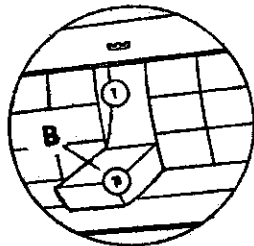
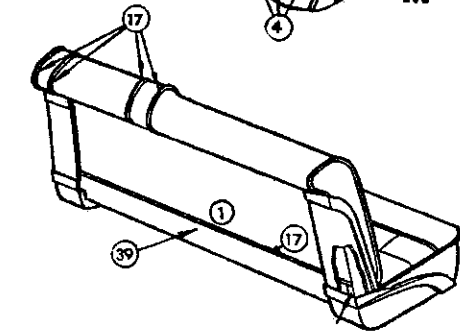
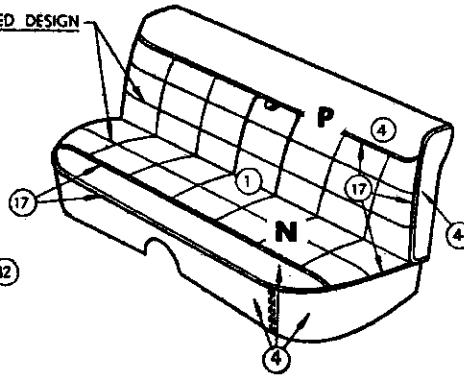

DISTRIBUTION OF MATERIAL

- 1 BODY CLOTH 1
- 4 IMITATION LEATHER 28-AM-22
- 5 IMITATION LEATHER 19-C-22
- 6 IMITATION LEATHER 19A-C-22
- 7 IMITATION LEATHER 12-Y-70
- 8 IMITATION LEATHER 19B-C-22
- 9 IMITATION LEATHER 22-AR-22
- 10 IMITATION LEATHER 19C-C-22
- 16 LACE
- 17 EXTRUDED VINYL
- 18 FLOOR COVERING-FRONT-CARPET
- 19 FLOOR COVERING-REAR-CARPET
- 20 FLOOR COVERING-LUGG. COMPT. CARPET
- 21 EMBOSSED CARDBOARD
- 30 PLASTIC
- 31 PAINT
- 32 METAL
- 33 MOULDING
- 36 MYLAR
- 38 MOULDED RESIN
- 39 CARPET
- 40 WOVEN PAPER

Distribution Drawing Legend Page Appears Following Illustration Section

Codes 331, 333, 334, 335

SCH-411

1962 CHRYSLER SC3-H 4 DOOR SEDAN
CLOTH & IMITATION LEATHER TRIM

1962 CHRYSLER - S SERIES

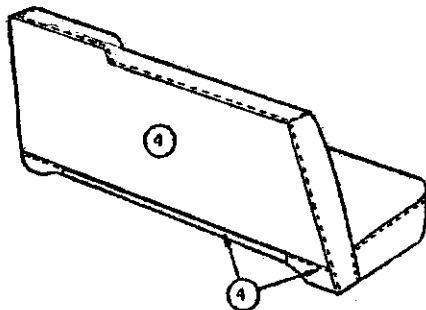
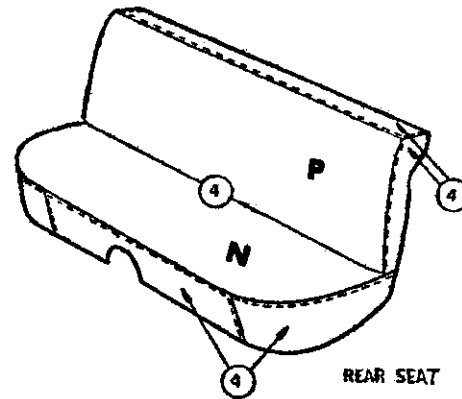
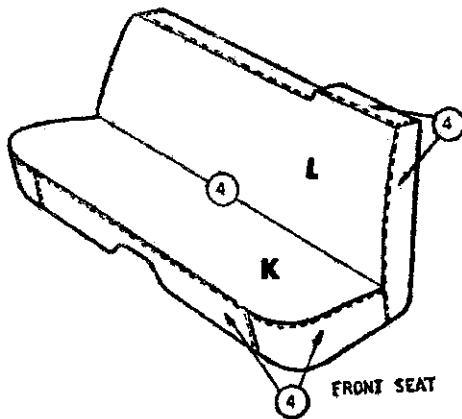
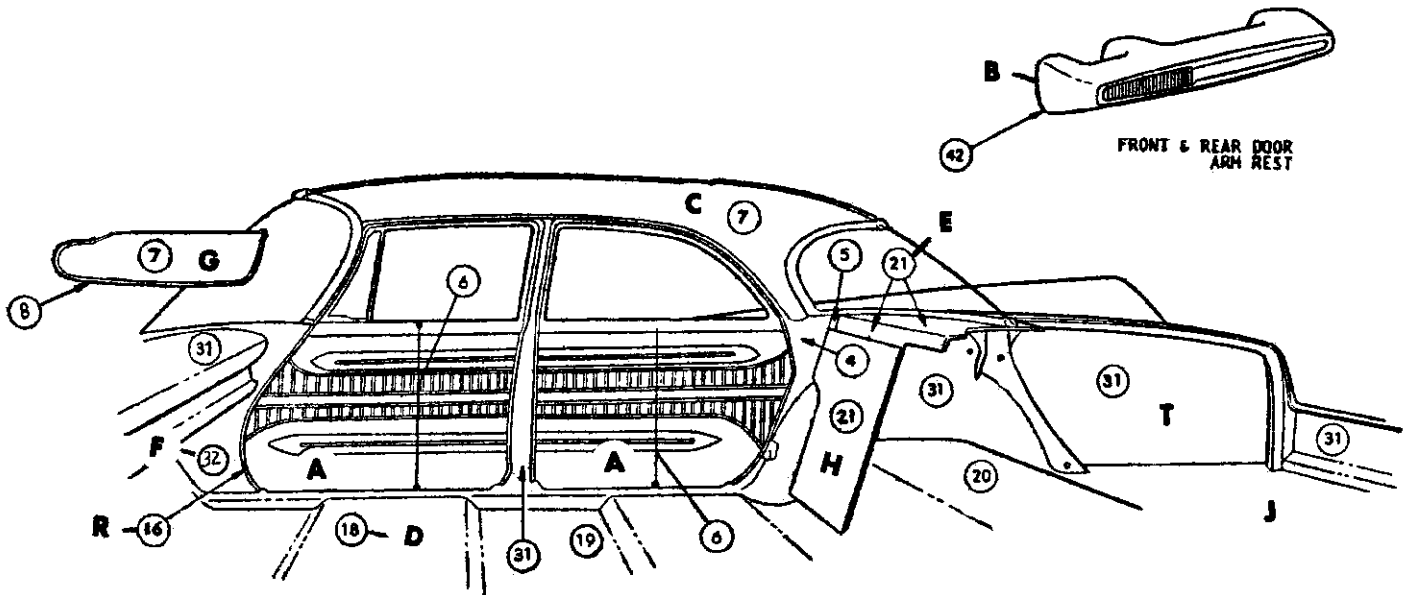

DISTRIBUTION OF MATERIAL

- 4 IMITATION LEATHER 37-CX-22
- 5 IMITATION LEATHER 19-C-22
- 6 IMITATION LEATHER .012-L-22
- 7 IMITATION LEATHER 12-Y-70
- 8 IMITATION LEATHER 19A-C-22
- 16 LACE
- 17 EXTRUDED VINYL
- 18 FLOOR COVERING-FRONT-RUBBER
- 19 FLOOR COVERING-REAR-RUBBER
- 20 FLOOR COVERING-LUGG. COMPT. RUBBER
- 21 EMBOSSSED CARDBOARD
- 30 PLASTIC
- 31 PAINT
- 32 METAL
- 36 MYLAR
- 38 MOULDED RESIN
- 42 PLASTISOL

Distribution Drawing Legend Page Appears Following Illustration Section

Code 444

SCL-414

1962 CHRYSLER SC1-L, SC3-H 4 DOOR SEDAN
IMITATION LEATHER TRIM

1962 CHRYSLER AND IMPERIAL - S SERIES

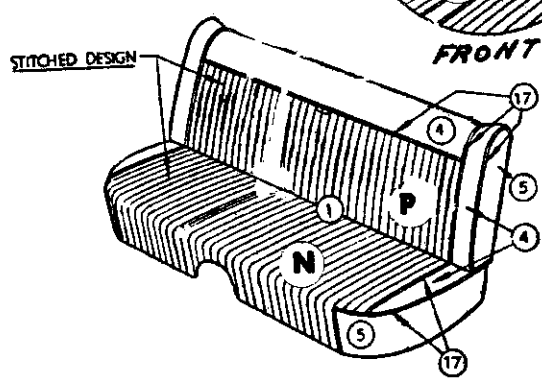
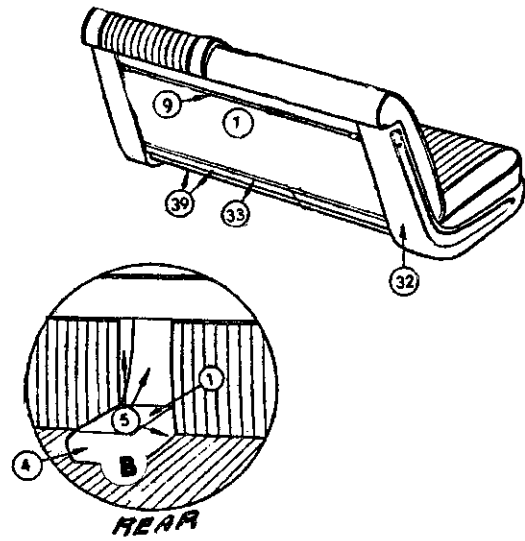
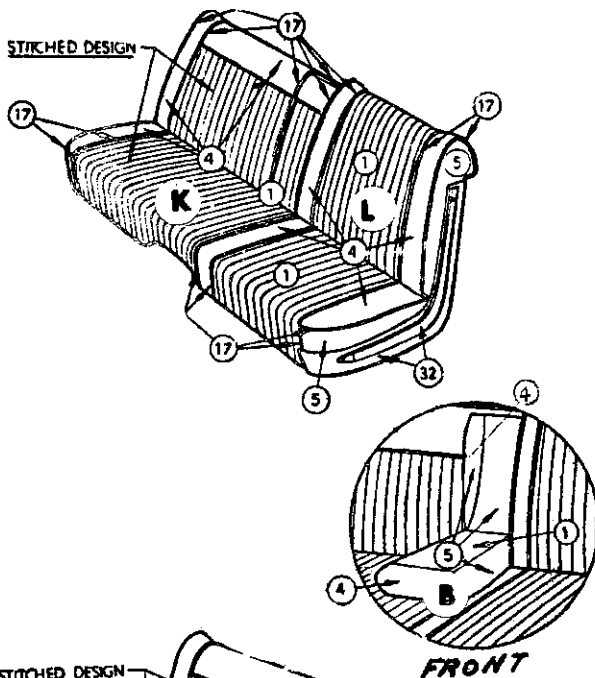
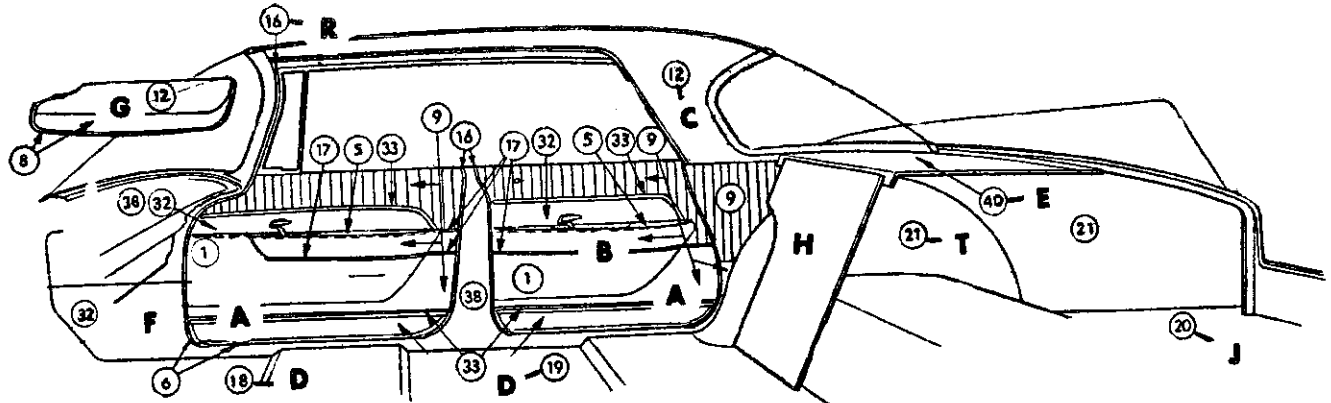

DISTRIBUTION OF MATERIAL

- 1 BODY CLOTH
- 4 LEATHER
- 5 IMITATION LEATHER 28-AM-22
- 6 IMITATION LEATHER 19-C-22
- 8 IMITATION LEATHER 19B-C-22
- 9 IMITATION LEATHER 22-AR-22
- 12 IMITATION LEATHER 19-C-5
- 17 EXTRUDED VINYL
- 18 FLOOR COVERING-FRONT-CARPET
- 19 FLOOR COVERING-REAR-CARPET
- 20 FLOOR COVERING-LUGG. COMPT. CARPET
- 21 EMBOSSSED CARDBOARD
- 30 PLASTIC
- 31 PAINT
- 32 METAL
- 33 MOULDING
- 35 POLYETHYLENE
- 36 MYLAR
- 38 MOULDED RESIN
- 39 CARPET
- 40 WOVEN PAPER

Distribution Drawing Legend Page Appears Following Illustration Section

Codes 511, 512, 513, 514, 515, 516

SYM-435

1962 IMPERIAL SY1-M SPECIAL 4 DOOR SEDAN
CLOTH AND LEATHER COMBINATION

1962 CHRYSLER AND IMPERIAL - S SERIES

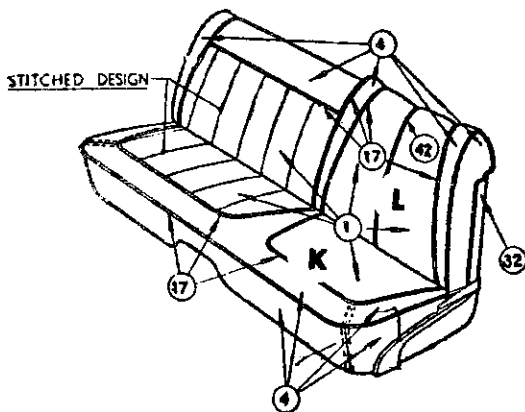
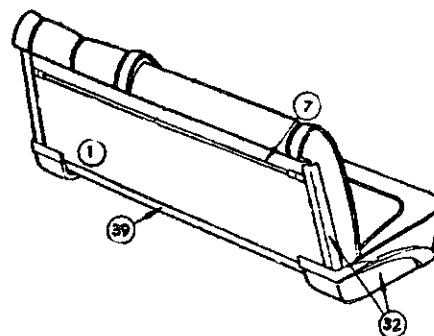
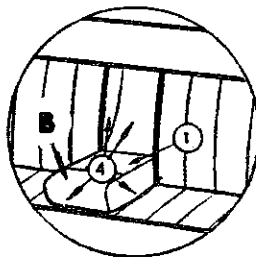
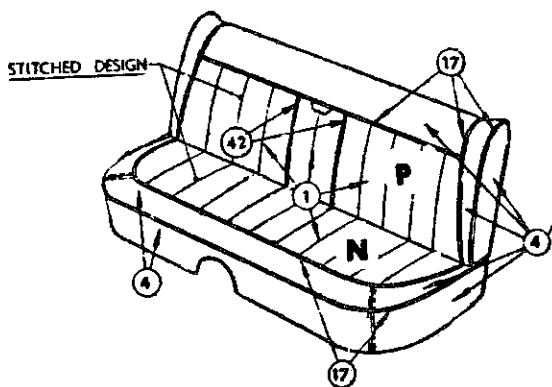
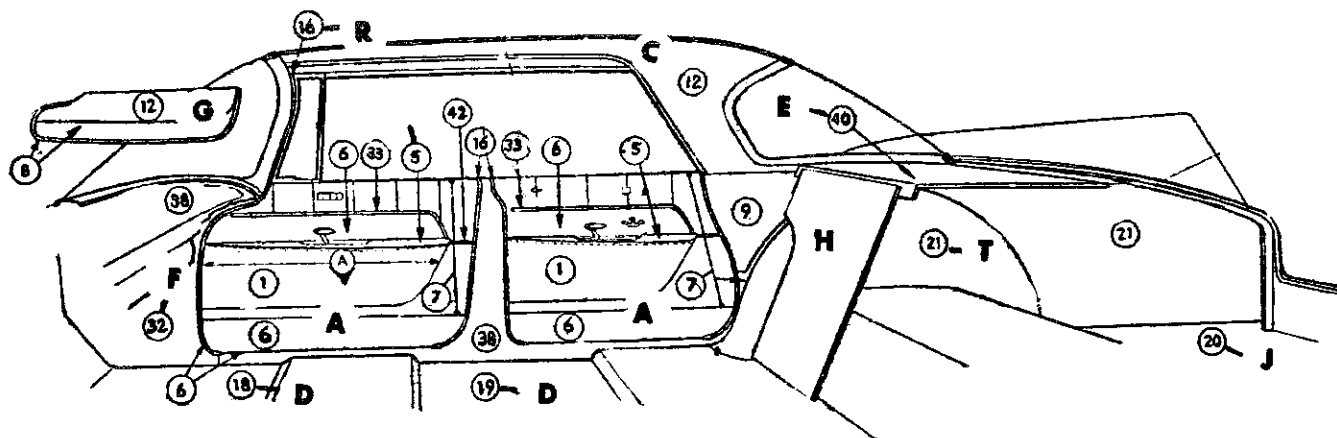

DISTRIBUTION OF MATERIAL

- 1 BODY CLOTH 1
- 4 IMITATION LEATHER 28-AM-22
- 5 IMITATION LEATHER 28A-AM-22
- 6 IMITATION LEATHER 19C-C-22
- 7 IMITATION LEATHER 22-AR-22
- 8 IMITATION LEATHER 19B-C-22
- 9 IMITATION LEATHER 19C-C-22
- 12 IMITATION LEATHER 19-C-5
- 17 EXTRUDED VINYL WELT NO.1
- 18 FLOOR COVERING-FRONT-CARPET
- 19 FLOOR COVERING-REAR-CARPET
- 20 FLOOR COVERING-LUGG. COMPT. CARPET
- 21 EMBOSSED CARDBOARD
- 30 PLASTIC
- 31 PAINT
- 32 METAL
- 33 MOULDING
- 35 POLYETHYLENE
- 36 MYLAR
- 38 MOULDED RESIN
- 39 CARPET
- 40 WOVEN PAPER
- 42 EXTRUDED VINYL WELT NO.2

Distribution Drawing Legend Page Appears Following Illustration Section

Codes 501, 502, 503, 504

SYL-431

1962 IMPERIAL SY1-L SPECIAL 4 DOOR SEDAN
CLOTH AND IMITATION LEATHER COMBINATION

1962 CHRYSLER - S SERIES

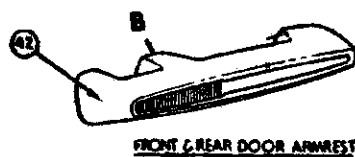
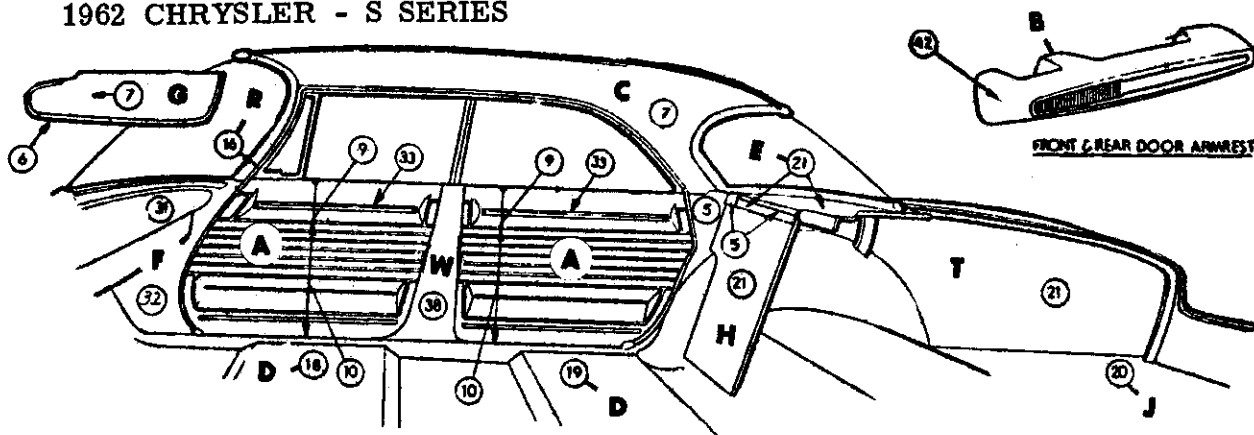

FRONT & REAR DOOR ARMREST

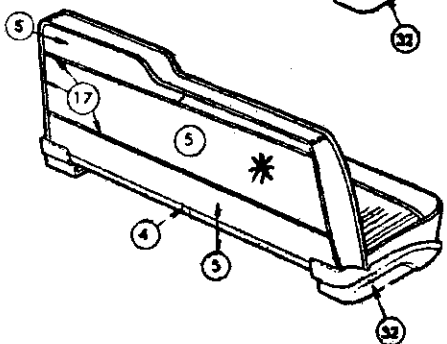
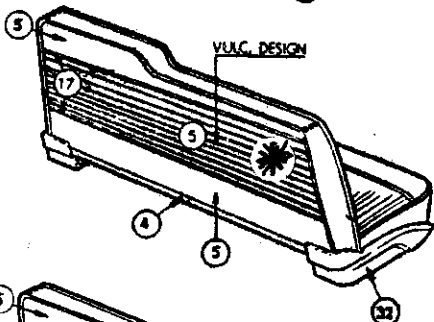
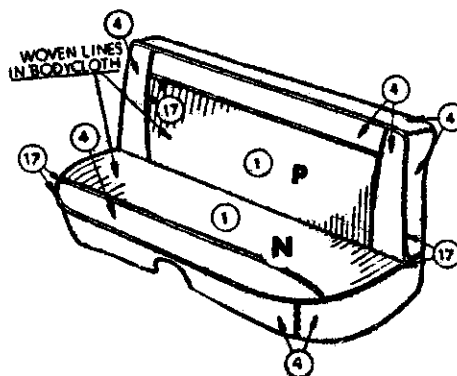
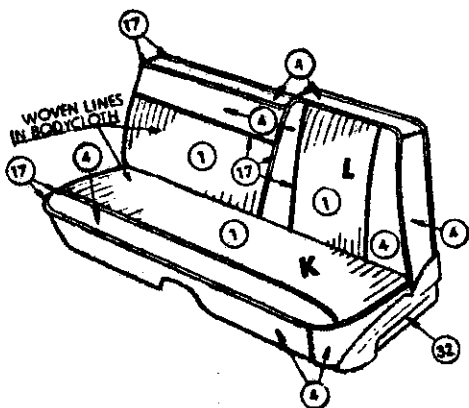

DISTRIBUTION OF MATERIAL

- 1 BODY CLOTH I
- 4 IMITATION LEATHER 28-AM-22
- 5 IMITATION LEATHER 19-C-22
- 6 IMITATION LEATHER 19A-C-22
- 7 IMITATION LEATHER 12-Y-70
- 9 IMITATION LEATHER 19-DJ-22
- 10 IMITATION LEATHER .012-L-22
- 16 LACE
- 17 EXTRUDED VINYL
- 18 FLOOR COVERING-FRONT-RUBBER
- 19 FLOOR COVERING-REAR-RUBBER
- 20 FLOOR COVERING-LUGG. COMPT. RUBBER
- 21 EMBOSSED CARDBOARD
- 30 PLASTIC
- 31 PAINT
- 32 METAL
- 33 MOULDING
- 35 POLYETHYLENE
- 36 MYLAR
- 38 MOULDED RESIN
- 39 CARPET
- 41 MOULDED VINYL
- 42 PLASTISOL

* Early Type w/Insert
Late Type w/o Insert

Distribution Drawing Legend Page Appears Following Illustration Section

Codes 301, 303, 304, 305

SCL-431

1962 CHRYSLER SC1-L 4 DOOR HARD TOP
CLOTH & IMITATION LEATHER TRIM

1962 CHRYSLER - S SERIES

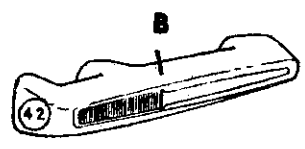
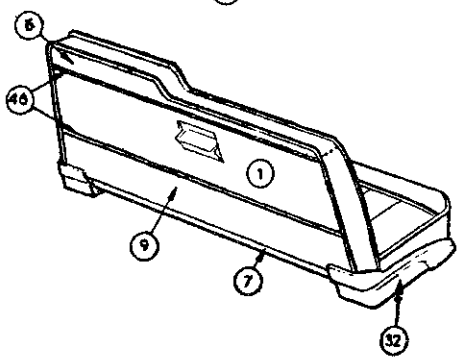
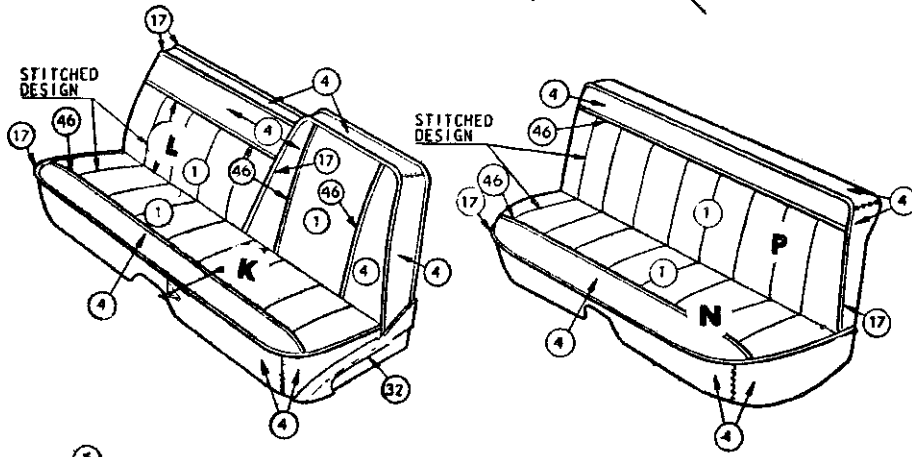
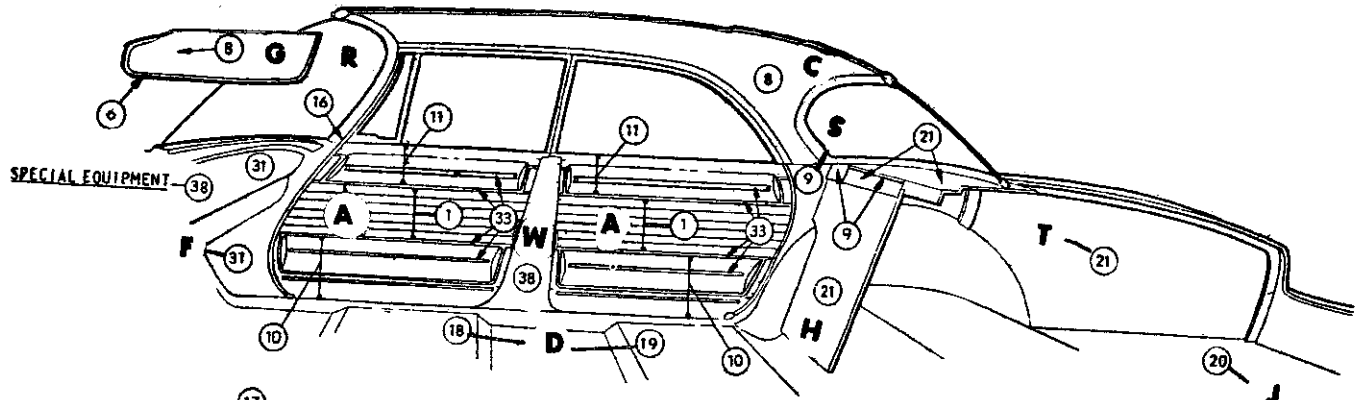

FRONT & REAR DOOR ARMREST

DISTRIBUTION OF MATERIAL

- 1 BODY CLOTH I
- 4 IMITATION LEATHER 28-AM-22
- 6 IMITATION LEATHER 19-C-22
- 7 IMITATION LEATHER 28A-AM-22
- 8 IMITATION LEATHER 17-C-81
- 9 IMITATION LEATHER 19A-C-22
- 10 IMITATION LEATHER .012-L-22
- 11 IMITATION LEATHER 19-DJ-22
- 16 LACE
- 17 EXTRUDED VINYL NO. 1
- 18 FLOOR COVERING-FRONT-CARPET
- 19 FLOOR COVERING-REAR-CARPET
- 20 FLOOR COVERING-LUGG. COMPT. RUBBER
- 21 EMBOSSED CARDBOARD
- 30 PLASTIC
- 31 PAINT
- 32 METAL
- 33 MOULDING
- 36 MYLAR
- 38 MOULDED RESIN
- 42 PLASTISOL
- 46 EXTRUDED VINYL NO. 2

Distribution Drawing Legend Page Appears Following Illustration Section

Codes 302, 308

SCL-431A

1962 CHRYSLER SC1-L 4 DOOR HARD TOP
CLOTH & IMITATION LEATHER TRIM

1962 CHRYSLER - S SERIES

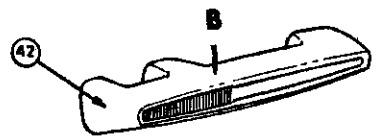
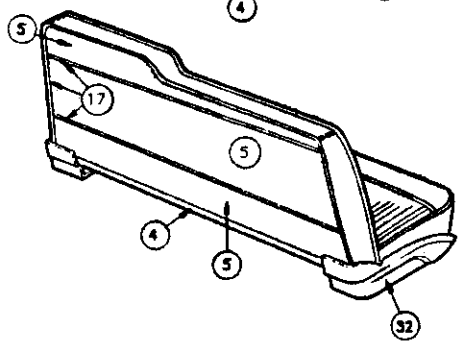
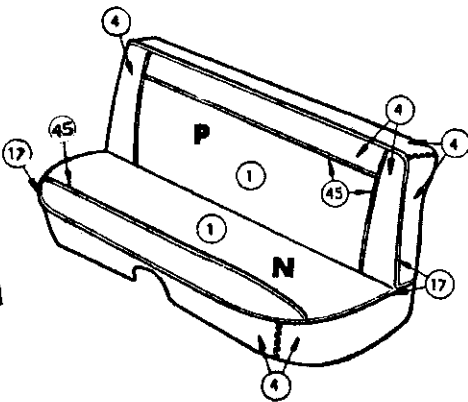
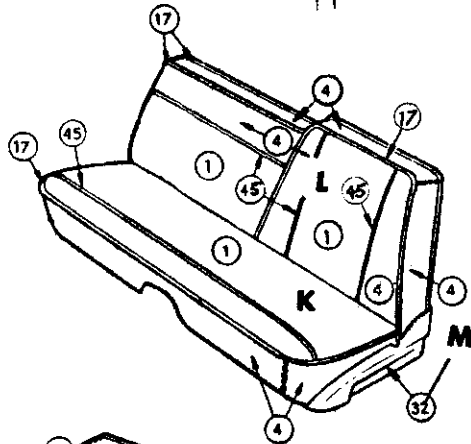
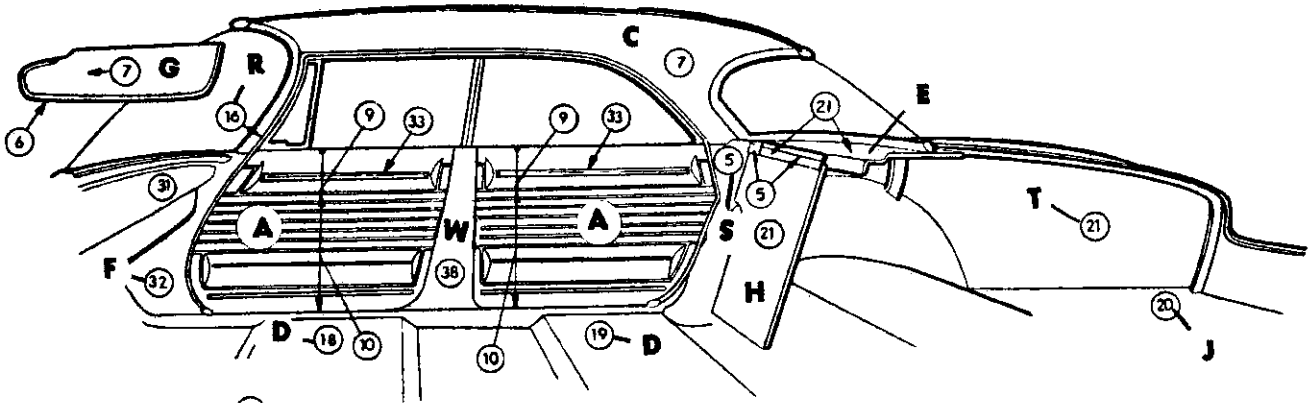

FRONT & REAR DOOR ARMREST

DISTRIBUTION OF MATERIAL

- 1 BODY CLOTH I
- 4 IMITATION LEATHER 28-AM-22
- 5 IMITATION LEATHER 19-C-22
- 6 IMITATION LEATHER 19A-C-22
- 7 IMITATION LEATHER 12-Y-70
- 9 IMITATION LEATHER 19-DJ-22
- 10 IMITATION LEATHER .012-L-22
- 16 LACE
- 17 EXTRUDED VINYL
- 18 FLOOR COVERING-FRONT-RUBBER
- 19 FLOOR COVERING-REAR-RUBBER
- 20 FLOOR COVERING-LUGG. COMPT. -RUBBER
- 21 EMBOSSED CARDBOARD
- 30 PLASTIC
- 31 PAINT
- 32 METAL
- 33 MOULDING
- 35 POLYETHYLENE
- 36 MYLAR
- 38 MOULDED RESIN
- 39 CARPET
- 41 MOULDED VINYL
- 42 PLASTISOL
- 45 MYLAR WELT

Distribution Drawing Legend Page Following Illustration Section

Codes 341, 343, 344, 345

SCL-431B

1962 CHRYSLER SC1-L 4 DOOR HARD TOP
CLOTH & IMITATION LEATHER TRIM

1962 CHRYSLER - S SERIES

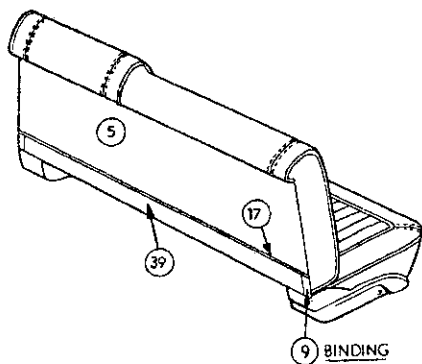
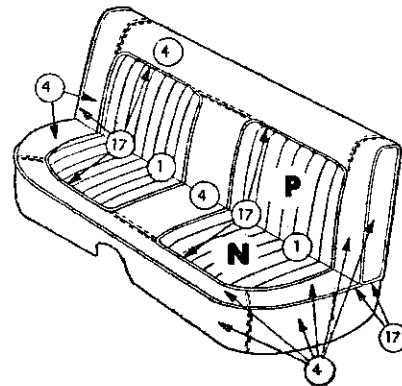
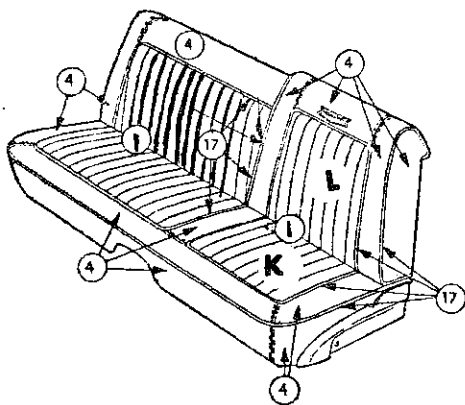
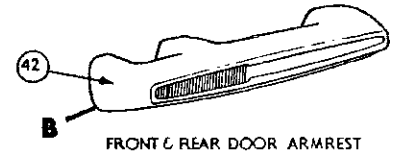
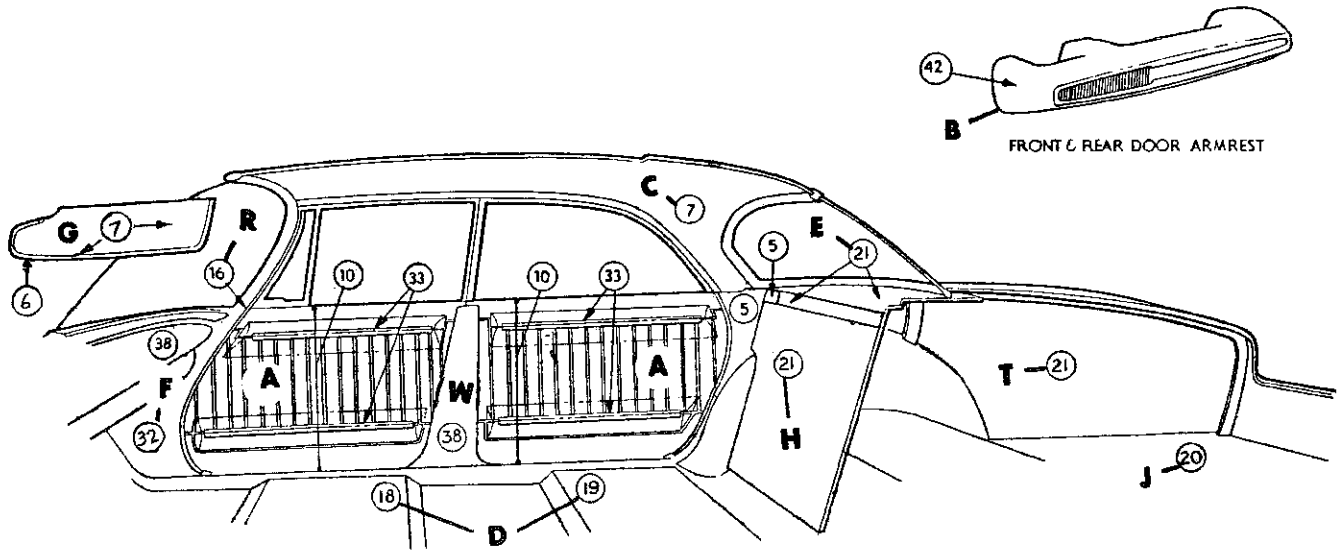

DISTRIBUTION OF MATERIAL

- 1 BODY CLOTH 1
- 4 IMITATION LEATHER 28-AM-22
- 5 IMITATION LEATHER 19-C-22
- 6 IMITATION LEATHER 19A-C-22
- 7 IMITATION LEATHER 12-Y-70
- 9 IMITATION LEATHER 19B-C-22
- 10 IMITATION LEATHER 19-DJ-22
- 16 LACE
- 17 EXTRUDED VINYL
- 18 FLOOR COVERING-FRONT-CARPET
- 19 FLOOR COVERING-REAR-CARPET
- 20 FLOOR COVERING-LUGG. COMPT. RUBBER
- 21 EMBOSSED CARDBOARD
- 30 PLASTIC
- 31 PAINT
- 32 METAL
- 33 MOULDING
- 36 MYLAR
- 38 MOULDED RESIN
- 39 CARPET
- 42 PLASTISOL

Distribution Drawing Legend Page Appears Following Illustration Section

Codes 313, 314, 315

SCM-431

1962 CHRYSLER SC2-M 4 DOOR HARD TOP
CLOTH & IMITATION LEATHER TRIM

1962 CHRYSLER - S SERIES

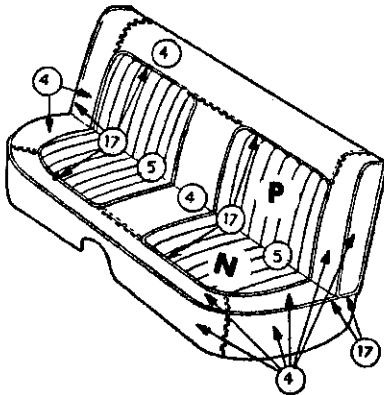
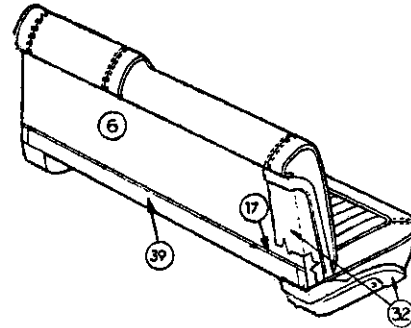
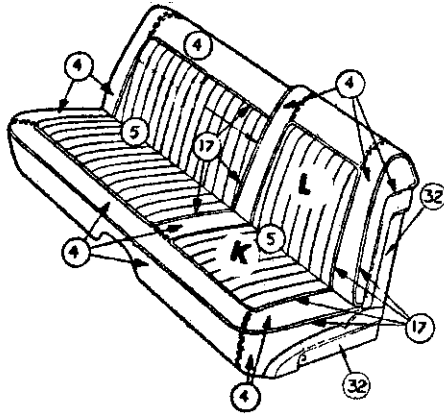
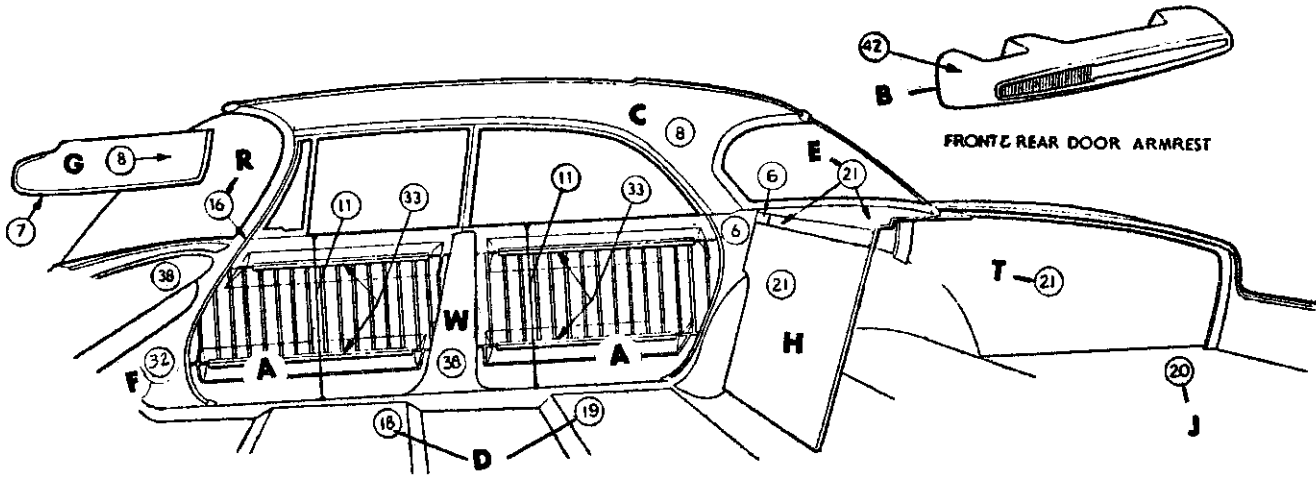

DISTRIBUTION OF MATERIAL

- 4 IMITATION LEATHER 28-AM-22
- 5 IMITATION LEATHER 28-AM-46
- 6 IMITATION LEATHER 19-C-22
- 7 IMITATION LEATHER 19A-C-22
- 8 IMITATION LEATHER 12-Y-70
- 10 IMITATION LEATHER 19B-C-22
- 11 IMITATION LEATHER 19-DJ-22
- 16 LACE
- 17 EXTRUDED VINYL
- 18 FLOOR COVERING-FRONT-CARPET
- 19 FLOOR COVERING-REAR-CARPET
- 20 FLOOR COVERING-LUGG. COMPT. RUBBER
- 21 EMBOSSED CARDBOARD
- 30 PLASTIC
- 31 PAINT
- 32 METAL
- 33 MOULDING
- 36 MYLAR
- 38 MOULDED RESIN
- 39 CARPET
- 42 PLASTISOL

Distribution Drawing Legend Page Appears Following Illustration Section

Codes 413, 414, 415

SCM-434

1962 CHRYSLER SC2-M 4 DOOR HARD TOP
IMITATION LEATHER TRIM

1962 CHRYSLER - S SERIES

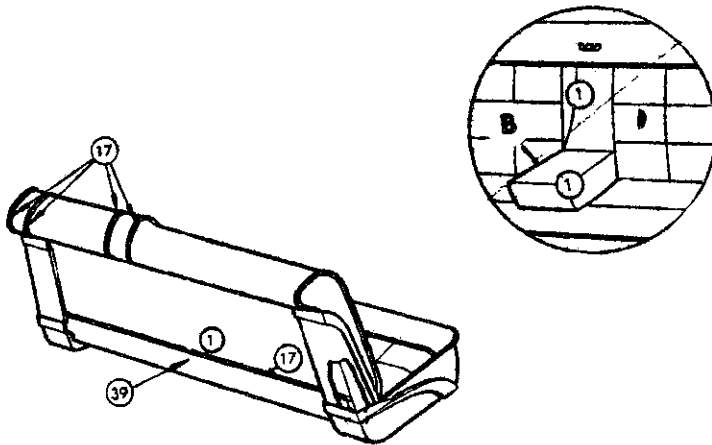
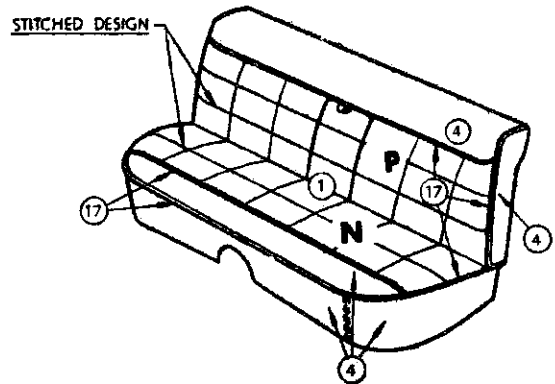
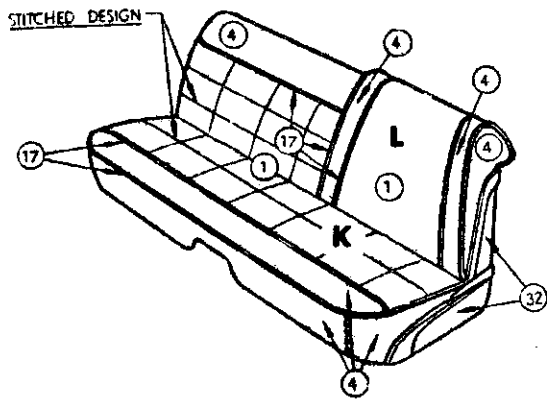
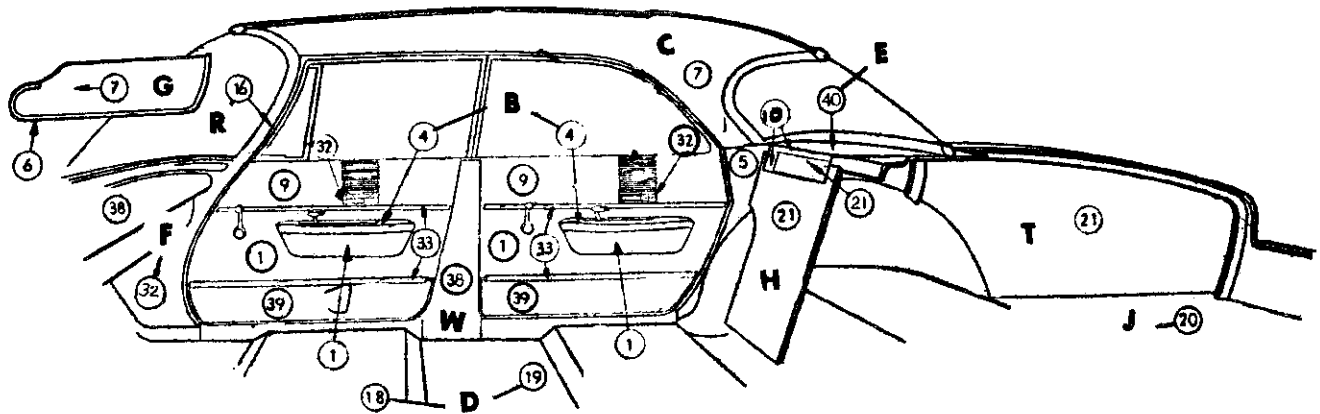

DISTRIBUTION OF MATERIAL

- 1 BODY CLOTH 1
- 4 IMITATION LEATHER 28-AM-22
- 5 IMITATION LEATHER 19-C-22
- 6 IMITATION LEATHER 19A-C-22
- 7 IMITATION LEATHER 12-Y-70
- 8 IMITATION LEATHER 19B-C-22
- 9 IMITATION LEATHER 22-AR-22
- 10 IMITATION LEATHER 19C-C-22
- 16 LACE
- 17 EXTRUDED VINYL
- 18 FLOOR COVERING-FRONT-CARPET
- 19 FLOOR COVERING-REAR-CARPET
- 20 FLOOR COVERING-LUGG. COMPT. CARPET
- 21 EMBOSSED CARDBOARD
- 30 PLASTIC
- 31 PAINT
- 32 METAL
- 33 MOULDING
- 36 MYLAR
- 38 MOULDED RESIN
- 39 CARPET
- 40 WOVEN PAPER

Distribution Drawing Legend Page Appears Following Illustration Section

Codes 331, 333, 334, 335

SCH-431

1962 CHRYSLER SC3-H 4 DOOR HARD TOP
CLOTH & IMITATION LEATHER TRIM

1962 CHRYSLER - S SERIES

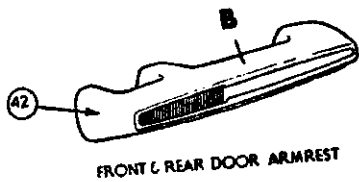
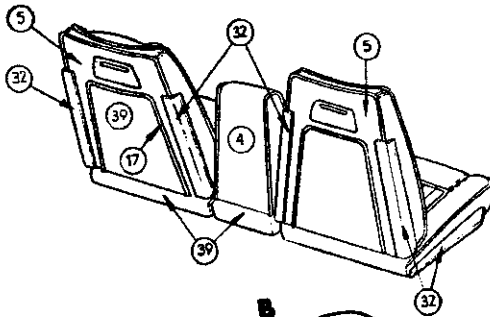
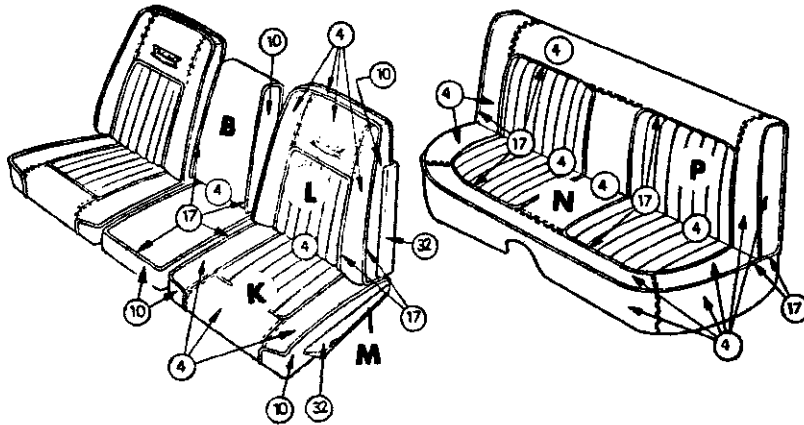
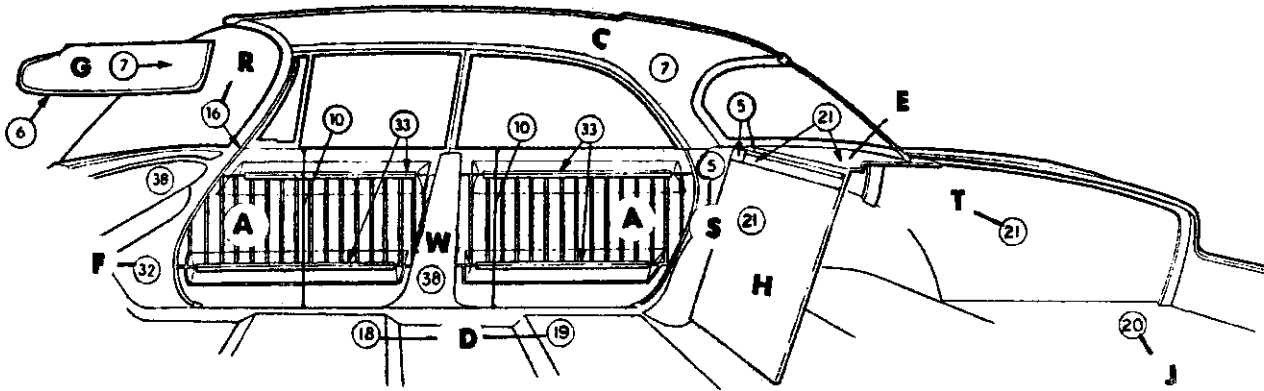

DISTRIBUTION OF MATERIAL

4	IMITATION LEATHER	28-AM-22
5	IMITATION LEATHER	19-C-22
6	IMITATION LEATHER	19A-C-22
7	IMITATION LEATHER	12-Y-70
9	IMITATION LEATHER	19B-C-22
10	IMITATION LEATHER	19-DJ-22
16	LACE	
17	EXTRUDED VINYL	
18	FLOOR COVERING-FRONT-CARPET	
19	FLOOR COVERING-REAR-CARPET	
20	FLOOR COVERING-LUGG. COMPT. RUBBER	
21	EMBOSSED CARDBOARD	
30	PLASTIC	
31	PAINT	
32	METAL	
33	MOULDING	
36	MYLAR	
38	MOULDED RESIN	
39	CARPET	
42	PLASTISOL	

Distribution Drawing Legend Page Appears Following Illustration Section

Codes 453, 454, 455

SCM-433

1962 CHRYSLER SC2-M 4 DOOR HARD TOP
LEATHER TRIM

1962 CHRYSLER - S SERIES

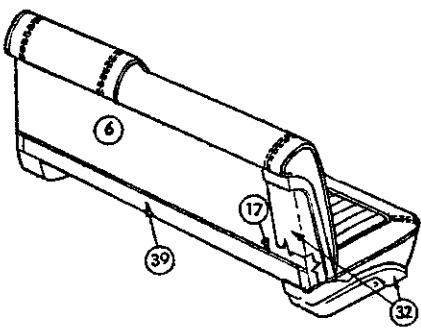
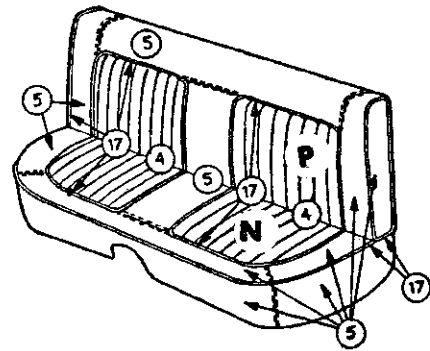
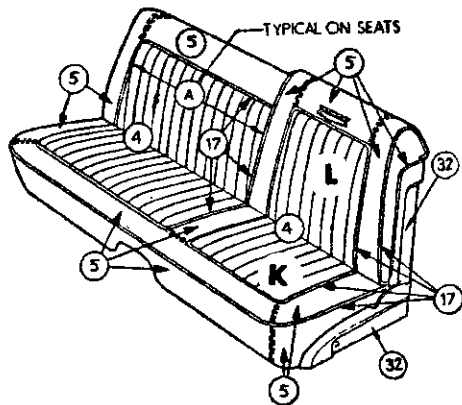
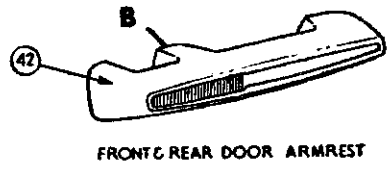
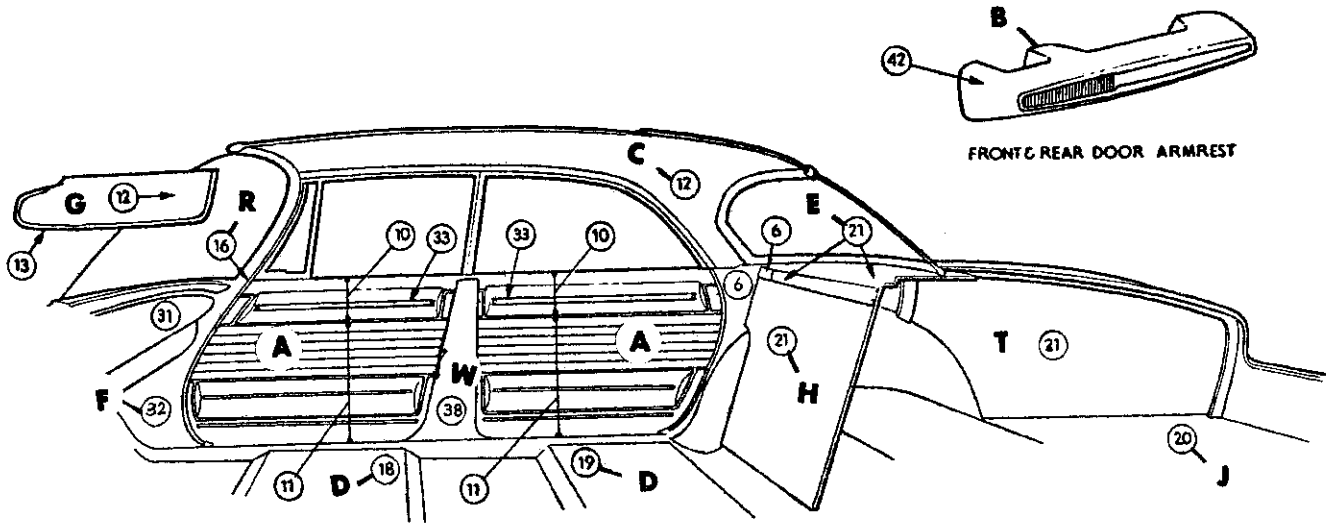

DISTRIBUTION OF MATERIAL

- 3 HEADLINING
- 4 IMITATION LEATHER 28-AM-46
- 5 IMITATION LEATHER 28-AM-22
- 6 IMITATION LEATHER 19-C-22
- 9 IMITATION LEATHER 19B-C-22
- 10 IMITATION LEATHER 19-DJ-22
- 11 IMITATION LEATHER .012-L-22
- 12 IMITATION LEATHER 12A-Y-70
- 13 IMITATION LEATHER 19C-C-22
- 16 LACE
- 17 EXTRUDED VINYL
- 18 FLOOR COVERING-FRONT-RUBBER
- 19 FLOOR COVERING-REAR-RUBBER
- 20 FLOOR COVERING-LUGG. COMPT. RUBBER
- 21 EMBOSSED CARDBOARD
- 30 PLASTIC
- 31 PAINT
- 32 METAL
- 33 MOULDING
- 36 MYLAR
- 38 MOULDED RESIN
- 39 CARPET
- 42 PLASTISOL

Distribution Drawing Legend Page Appears Following Illustration Section
Codes 404, 405

SCL-434

1962 CHRYSLER SC1-L 4 DOOR HARD TOP
IMITATION LEATHER TRIM

1962 CHRYSLER - S SERIES

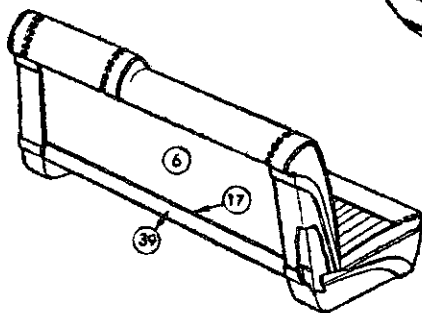
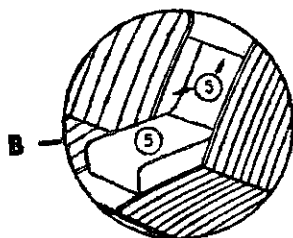
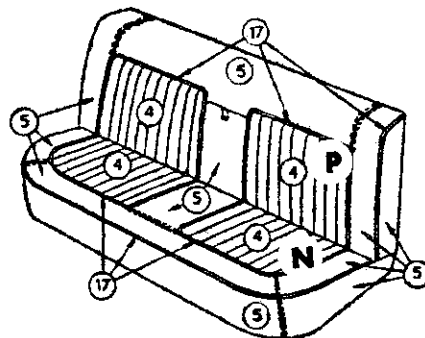
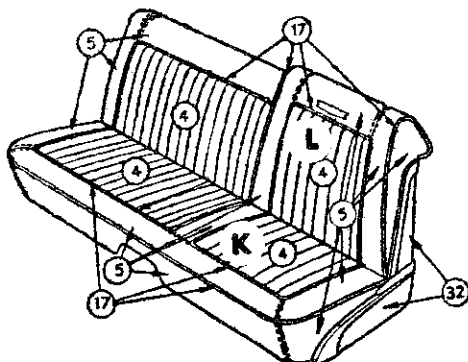
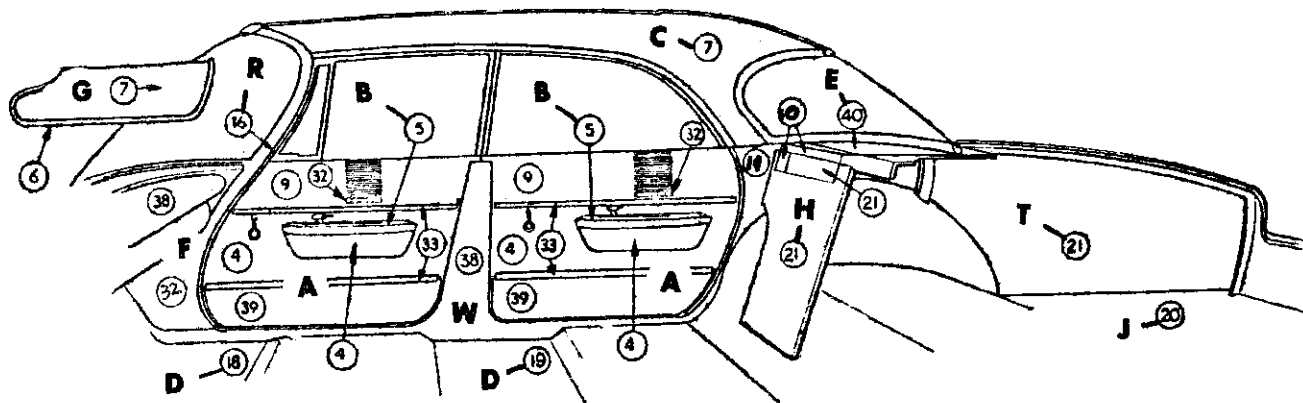

DISTRIBUTION OF MATERIAL

4	IMITATION LEATHER	28-AM-22
5	IMITATION LEATHER	28-AM-46
6	IMITATION LEATHER	19-C-22
7	IMITATION LEATHER	19A-C-22
8	IMITATION LEATHER	12-Y-70
9	IMITATION LEATHER	22-AR-22
10	IMITATION LEATHER	19B-C-22
11	IMITATION LEATHER	19-DJ-22
16	LACE	
17	EXTRUDED VINYL	
18	FLOOR COVERING-FRONT-CARPET	
19	FLOOR COVERING-REAR-CARPET	
20	FLOOR COVERING-LUGG. COMPT. CARPET	
21	EMBOSSED CARDBOARD	
30	PLASTIC	
31	PAINT	
32	METAL	
33	MOULDING	
35	POLYETHYLENE	
36	MYLAR	
38	MOULDED RESIN	
39	CARPET	
40	WOVEN PAPER	

Distribution Drawing Legend Page Appears Following Illustration Section

Codes 464, 465

SCH-434

1962 CHRYSLER SC3-H 4 DOOR HARD TOP
IMITATION LEATHER TRIM

1962 CHRYSLER - S SERIES

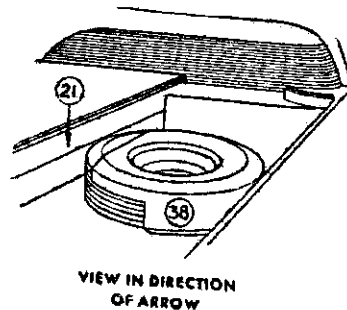
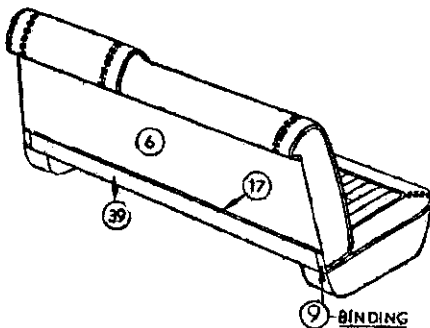
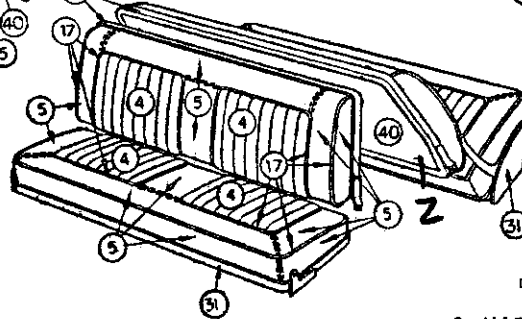
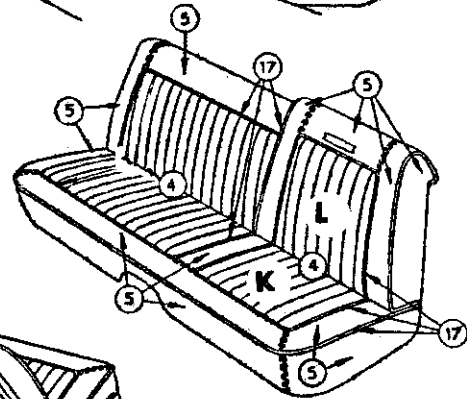
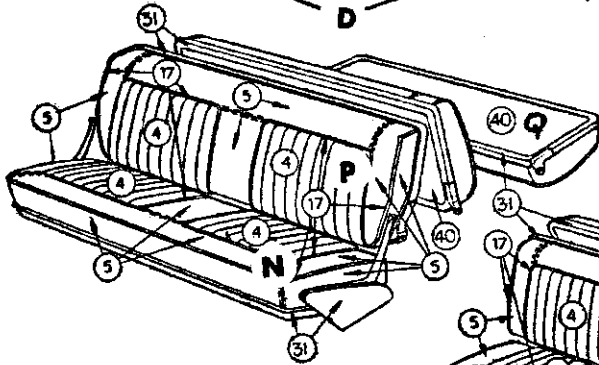
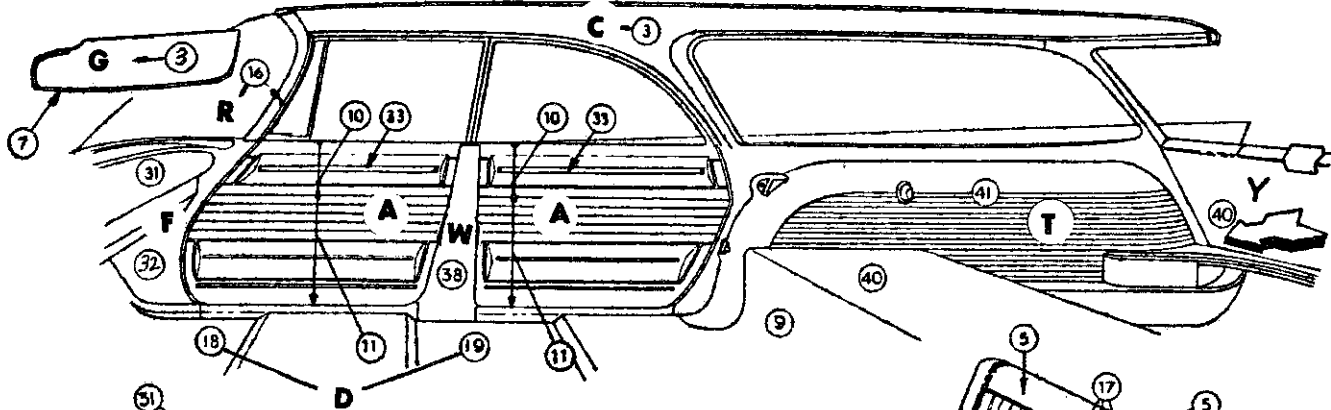

DISTRIBUTION OF MATERIAL

- 3 HARDBOARD
- 4 IMITATION LEATHER 28-AM-46
- 5 IMITATION LEATHER 28-AM-22
- 6 IMITATION LEATHER 19-C-22
- 7 IMITATION LEATHER 19A-C-22
- 8 IMITATION LEATHER 12-Y-70
- 9 IMITATION LEATHER 19B-C-22
- 10 IMITATION LEATHER 19-DJ-22
- 11 IMITATION LEATHER .012-L-22
- 16 LACE
- 17 EXTRUDED VINYL
- 18 FLOOR COVERING-FRONT-RUBBER
- 19 FLOOR COVERING-REAR-RUBBER
- 20 FLOOR COVERING-LUGG. COMPT.
- 21 EMBOSSED CARDBOARD
- 30 PLASTIC
- 31 PAINT
- 32 METAL
- 33 MOULDING
- 36 MYLAR
- 38 MOULDED RESIN
- 39 CARPET
- 40 VINOLEUM
- 41 MOULDED RUBBER
- 42 PLASTISOL

Distribution Drawing Legend Page Appears Following Illustration Section

Codes 403, 404, 405

SCL-464 1962 CHRYSLER SC1-L 4 DOOR HARD TOP STATION WAGON
IMITATION LEATHER TRIM

1962 CHRYSLER - S SERIES

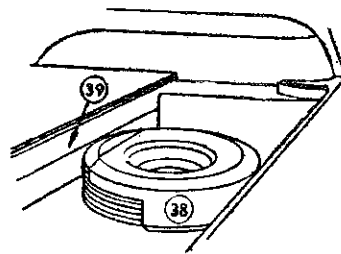
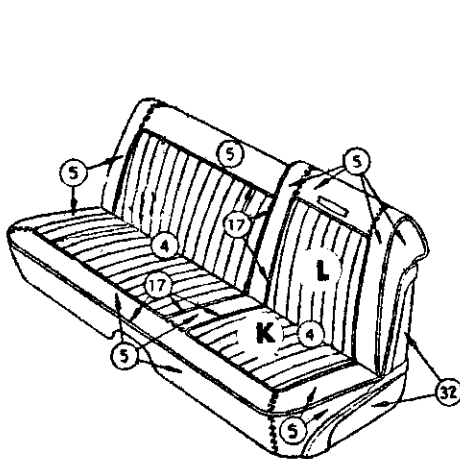
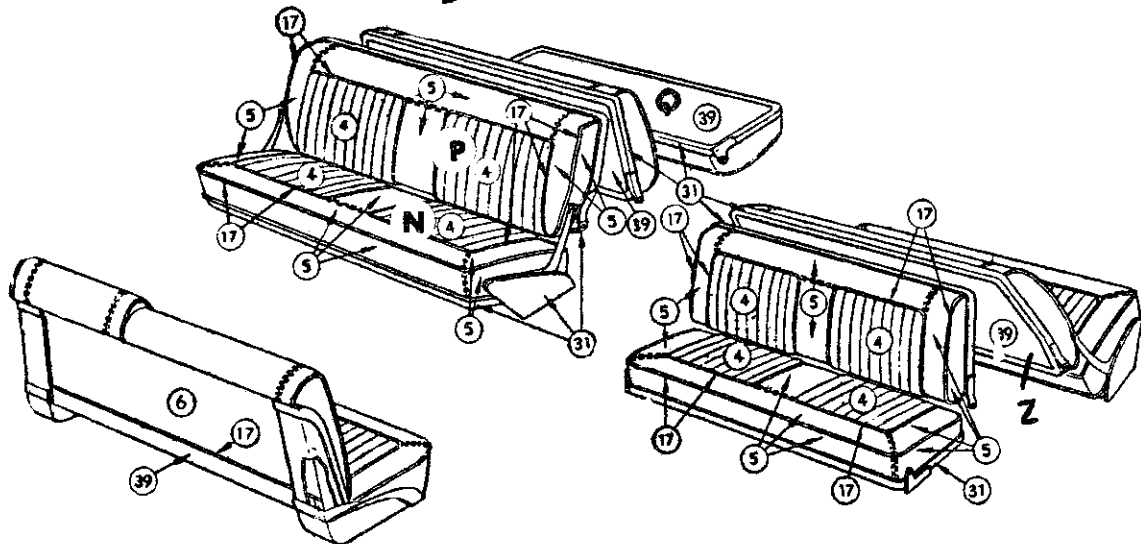
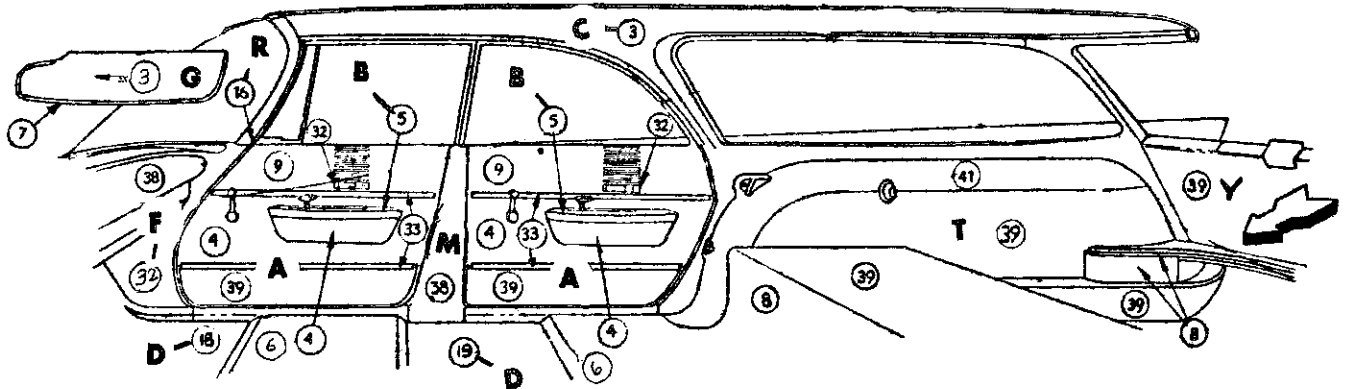

VIEW IN DIRECTION OF ARROW

DISTRIBUTION OF MATERIAL

- | | | |
|----|-----------------------------|----------|
| 3 | HARDBOARD | |
| 4 | IMITATION LEATHER | 28-AM-46 |
| 5 | IMITATION LEATHER | 28-AM-22 |
| 6 | IMITATION LEATHER | 19-C-22 |
| 7 | IMITATION LEATHER | 19A-C-22 |
| 8 | IMITATION LEATHER | 19B-C-22 |
| 9 | IMITATION LEATHER | 22-AR-22 |
| 10 | IMITATION LEATHER | 12-Y-70 |
| 16 | LACE | |
| 17 | EXTRUDED VINYL | |
| 18 | FLOOR COVERING-FRONT-CARPET | |
| 19 | FLOOR COVERING-REAR-CARPET | |
| 20 | FLOOR COVERING-LUGG. COMPT. | |
| 30 | PLASTIC | |
| 31 | PAINT | |
| 32 | METAL | |
| 33 | MOULDING | |
| 36 | MYLAR | |
| 38 | MOULDED RESIN | |
| 39 | CARPET | |
| 41 | MOULDED RUBBER | |

Distribution Drawing Legend Page Appears Following Illustration Section

Codes 423, 424, 425

SCH-464 1962 CHRYSLER SC3-H 4 DOOR HARD TOP STATION WAGON
IMITATION LEATHER TRIM

1962 CHRYSLER - S SERIES

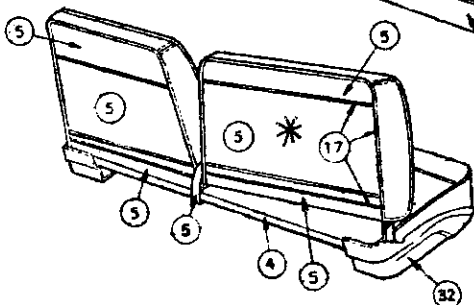
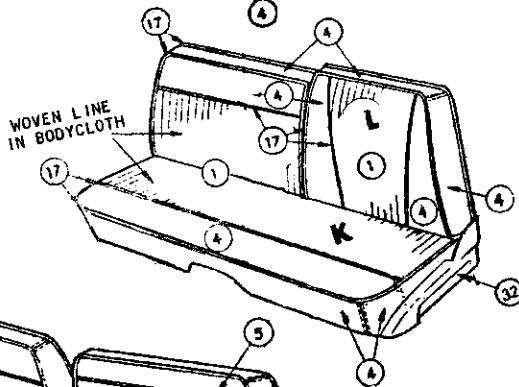
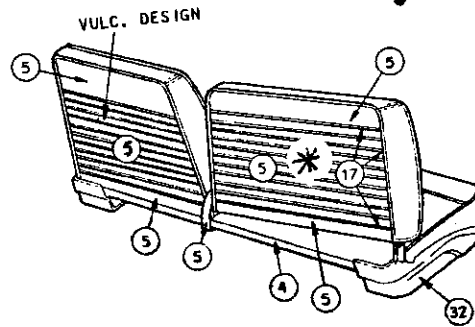
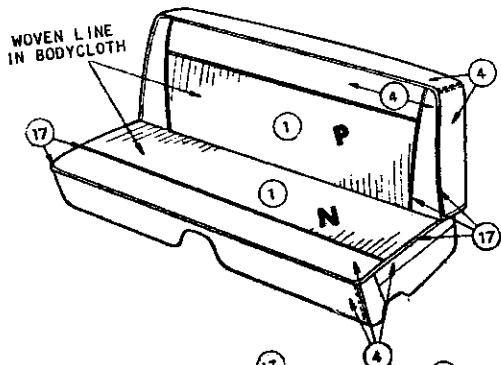
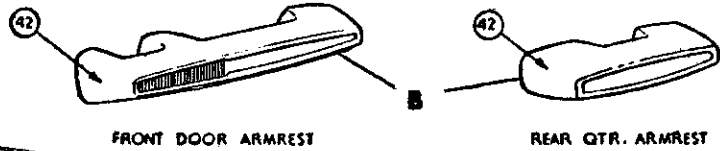
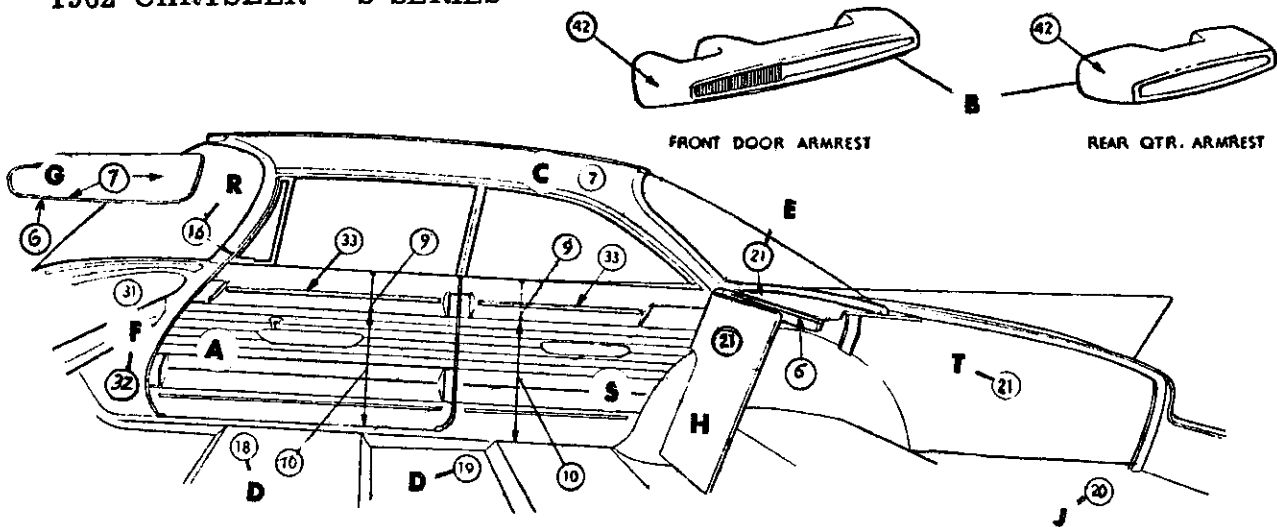

DISTRIBUTION OF MATERIAL

- 1 BODY CLOTH
- 4 IMITATION LEATHER
- 5 IMITATION LEATHER
- 6 IMITATION LEATHER
- 7 IMITATION LEATHER
- 8 IMITATION LEATHER
- 10 IMITATION LEATHER
- 16 LACE
- 17 EXTRUDED VINYL
- 18 FLOOR COVERING-FRONT-RUBBER
- 19 FLOOR COVERING-REAR-RUBBER
- 20 FLOOR COVERING-LUGG. COMPT. RUBBER
- 21 EMBOSSED CARDBOARD
- 30 PLASTIC
- 31 PAINT
- 32 METAL
- 33 MOULDING
- 36 MYLAR
- 38 MOULDED RESIN
- 39 CARPET
- 41 MOULDED VINYL
- 42 PLASTISOL

* Early Type w/Insert
Late Type w/o Insert

Distribution Drawing Legend Page Appears Following Illustration Section

Codes 301, 303, 304, 305

SCL-231

1962 CHRYSLER SC1-L 2 DOOR HARD TOP
CLOTH & IMITATION LEATHER TRIM

1962 CHRYSLER - S SERIES

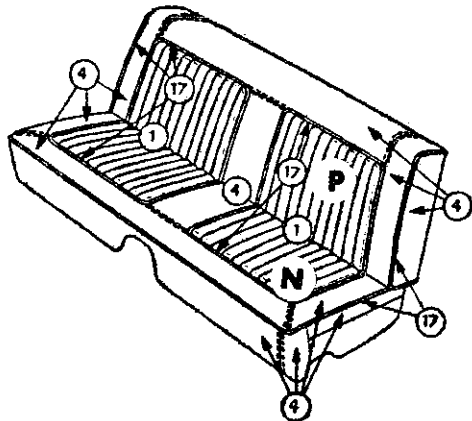
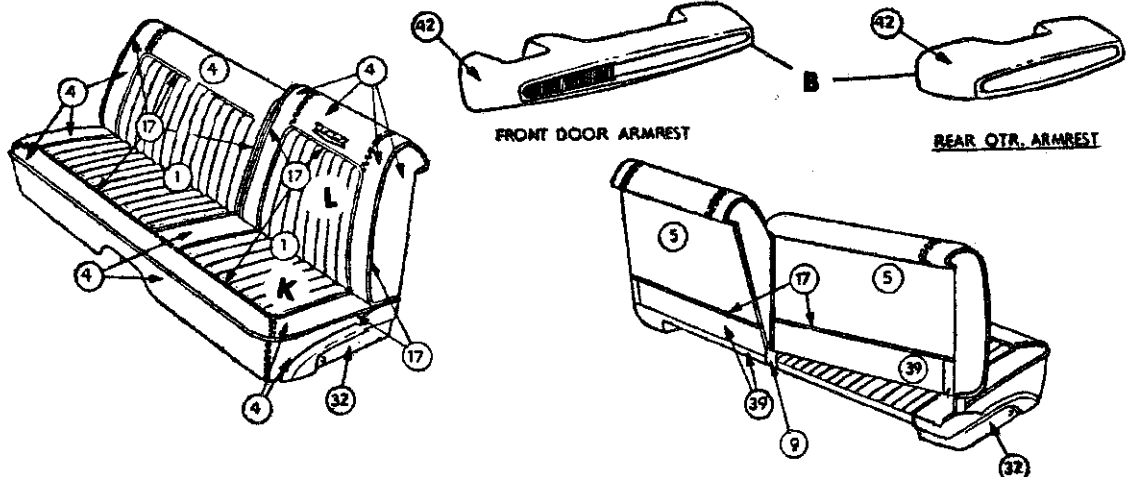
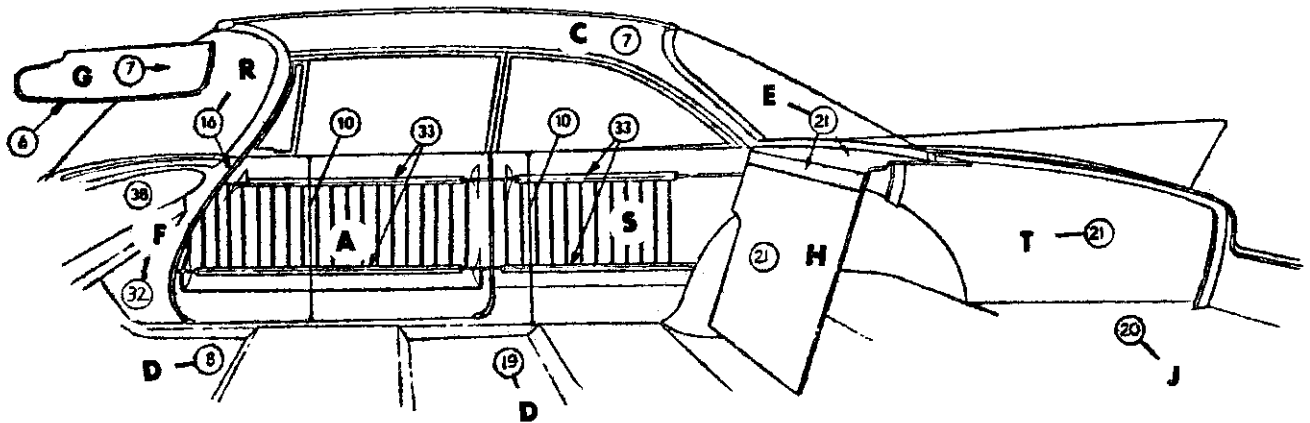

DISTRIBUTION OF MATERIAL

- 1 BODY CLOTH I
- 4 IMITATION LEATHER 28-AM-22
- 5 IMITATION LEATHER 19-C-22
- 6 IMITATION LEATHER 19A-C-22
- 7 IMITATION LEATHER 12-Y-70
- 9 IMITATION LEATHER 19B-C-22
- 10 IMITATION LEATHER 19-DJ-22
- 16 LACE
- 17 EXTRUDED VINYL
- 18 FLOOR COVERING-FRONT-CARPET
- 19 FLOOR COVERING-REAR-CARPET
- 20 FLOOR COVERING-LUGG. COMPT. RUBBER
- 21 EMBOSSED CARDBOARD
- 30 PLASTIC
- 31 PAINT
- 32 METAL
- 33 MOULDING
- 36 MYLAR
- 38 MOULDED RESIN
- 39 CARPET
- 42 PLASTISOL

Distribution Drawing Legend Page Appears Following Illustration Section

Codes 313, 314, 315

SCM-231

1962 CHRYSLER SC2-M 2 DOOR HARD TOP
CLOTH & IMITATION LEATHER COMB.

1962 CHRYSLER - S SERIES

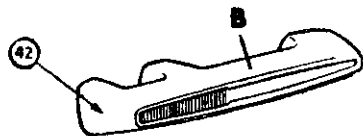
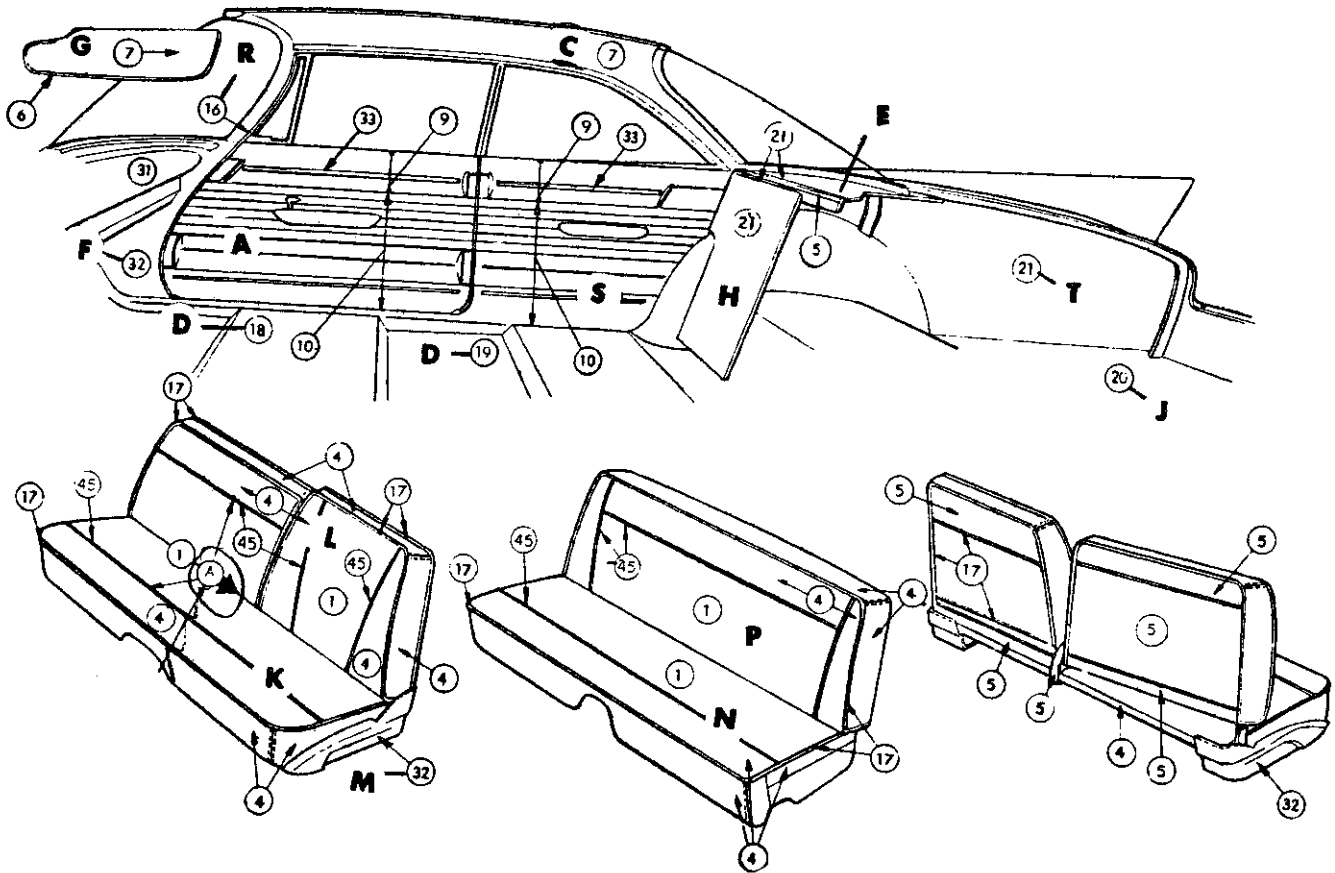

FRONT DOOR ARMREST



REAR QTR. ARMREST

DISTRIBUTION OF MATERIAL

- 1 BODY CLOTH 1
- 4 IMITATION LEATHER 28-AM-22
- 5 IMITATION LEATHER 19-C-22
- 6 IMITATION LEATHER 19A-C-22
- 7 IMITATION LEATHER 12-Y-70
- 9 IMITATION LEATHER 19-DJ-22
- 10 IMITATION LEATHER .012-L-22
- 16 LACE
- 17 EXTRUDED VINYL
- 18 FLOOR COVERING-FRONT-RUBBER
- 19 FLOOR COVERING-REAR-RUBBER
- 20 FLOOR COVERING-LUGG. COMPT. -RUBBER
- 21 EMBOSSED CARDBOARD
- 30 PLASTIC
- 31 PAINT
- 32 METAL
- 33 MOULDING
- 35 POLYETHYLENE
- 36 MYLAR
- 38 MOULDED RESIN
- 39 CARPET
- 41 MOULDED VINYL
- 42 PLASTISOL
- 45 MYLAR WELT

Distribution Drawing Legend Page Appears Following Illustration Section

Codes 341, 343, 344, 345

SCL-231B

1962 CHRYSLER SC1-L 2 DOOR HARD TOP
CLOTH & IMITATION LEATHER TRIM

1962 CHRYSLER - S SERIES

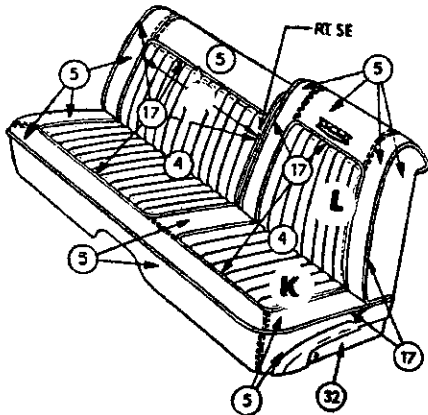
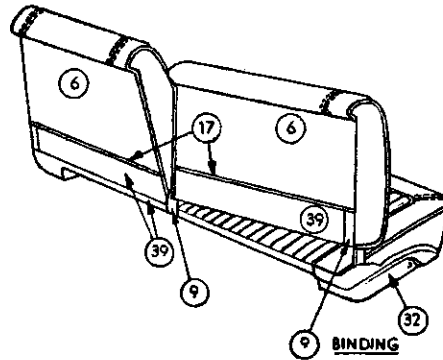
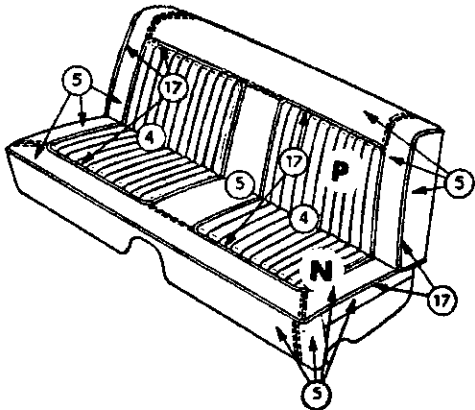
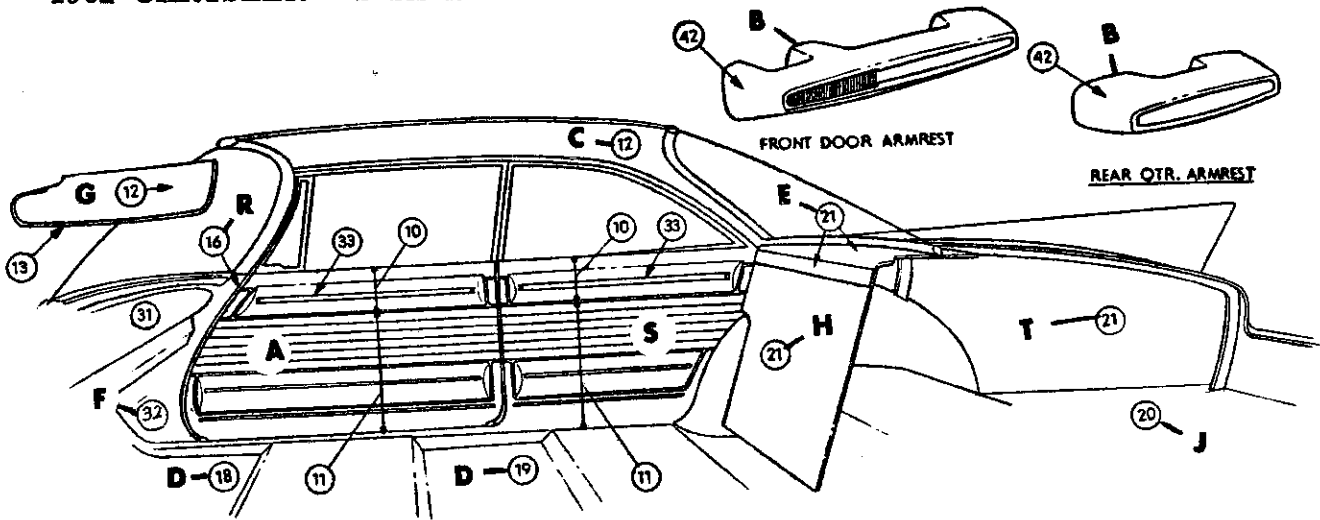

DISTRIBUTION OF MATERIAL

3	HEADLINING	
4	IMITATION LEATHER	28-AM-46
5	IMITATION LEATHER	28-AM-22
6	IMITATION LEATHER	19-C-22
9	IMITATION LEATHER	19B-C-22
10	IMITATION LEATHER	19-DJ-22
11	IMITATION LEATHER	.012-L-22
12	IMITATION LEATHER	12A-Y-70
13	IMITATION LEATHER	19C-C-22
16	LACE	
17	EXTRUDED VINYL	
18	FLOOR COVERING-FRONT-RUBBER	
19	FLOOR COVERING-REAR-RUBBER	
20	FLOOR COVERING-LUGG. COMPT. RUBBER	
21	EMBOSSED CARDBOARD	
30	PLASTIC	
31	PAINT	
32	METAL	
33	MOULDING	
35	POLYETHYLENE	
36	MYLAR	
38	MOULDED RESIN	
39	CARPET	
42	PLASTISOL	

Distribution Drawing Legend Page Appears Following Illustration Section
Codes 404, 405

SCL-234

1962 CHRYSLER SC1-L 2 DOOR HARD TOP
IMITATION LEATHER TRIM

1962 CHRYSLER - S SERIES

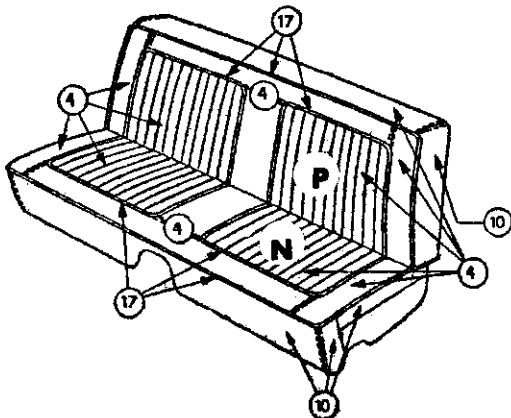
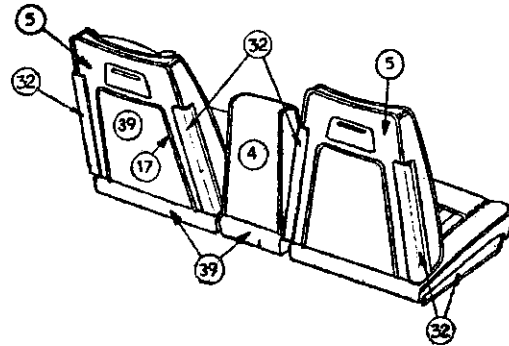
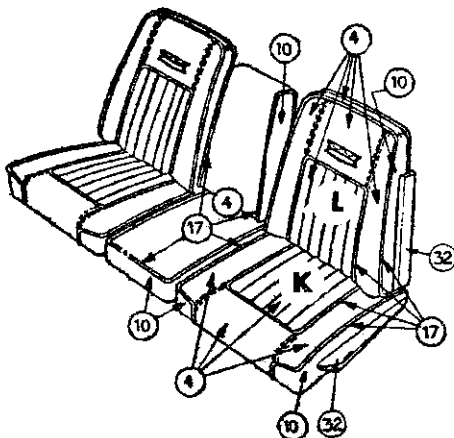
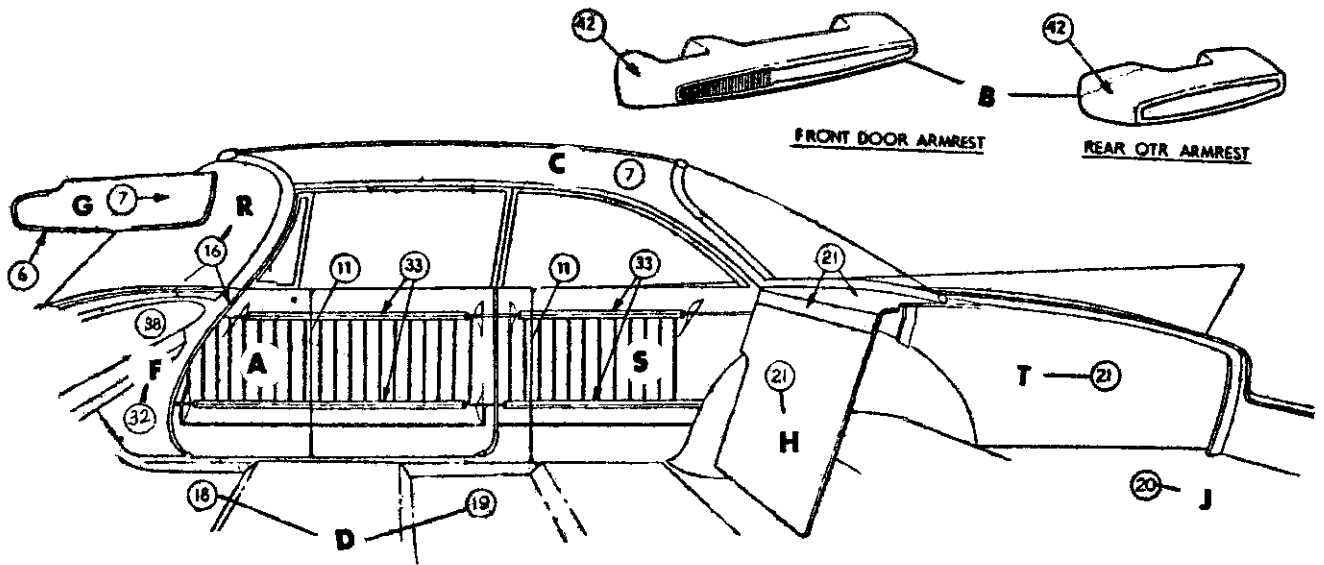

DISTRIBUTION OF MATERIAL

- 4 LEATHER
- 5 IMITATION LEATHER 19-C-22
- 6 IMITATION LEATHER 19A-C-22
- 7 IMITATION LEATHER 12-Y-70
- 9 IMITATION LEATHER 19B-C-22
- 10 IMITATION LEATHER 28-AM-22
- 11 IMITATION LEATHER 19-DJ-22
- 16 LACE
- 17 EXTRUDED VINYL
- 18 FLOOR COVERING-FRONT-CARPET
- 19 FLOOR COVERING-REAR-CARPET
- 20 FLOOR COVERING-LUGG. COMPT. RUBBER
- 21 EMBOSSED CARDBOARD
- 30 PLASTIC
- 31 PAINT
- 32 METAL
- 33 MOULDING
- 35 POLYETHYLENE
- 36 MYLAR
- 38 MOULDED RESIN
- 39 CARPET
- 42 PLASTISOL

Distribution Drawing Legend Page Appears Following Illustration Section

Codes 453, 454, 455

SCM-233

1962 CHRYSLER SC2-M 2 DOOR HARD TOP
LEATHER TRIM

1962 CHRYSLER - S SERIES

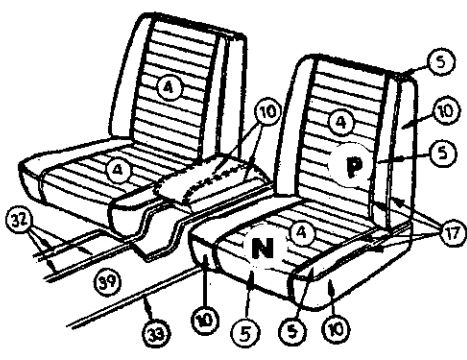
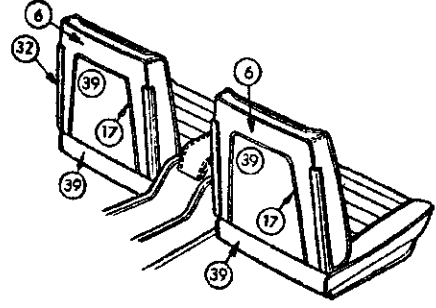
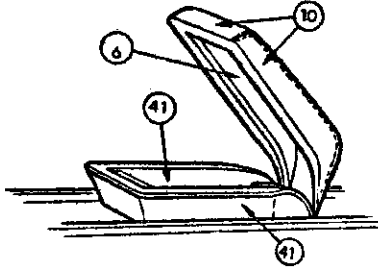
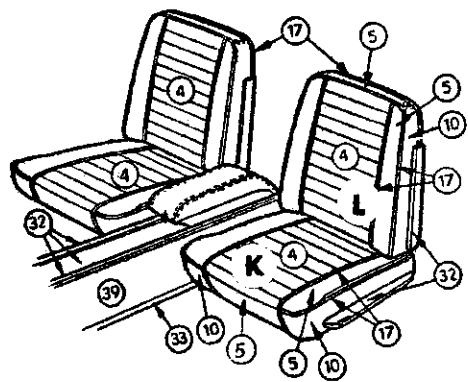
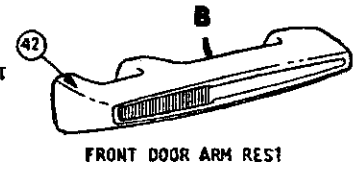
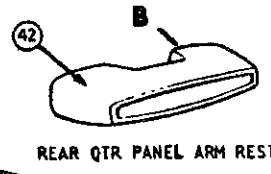
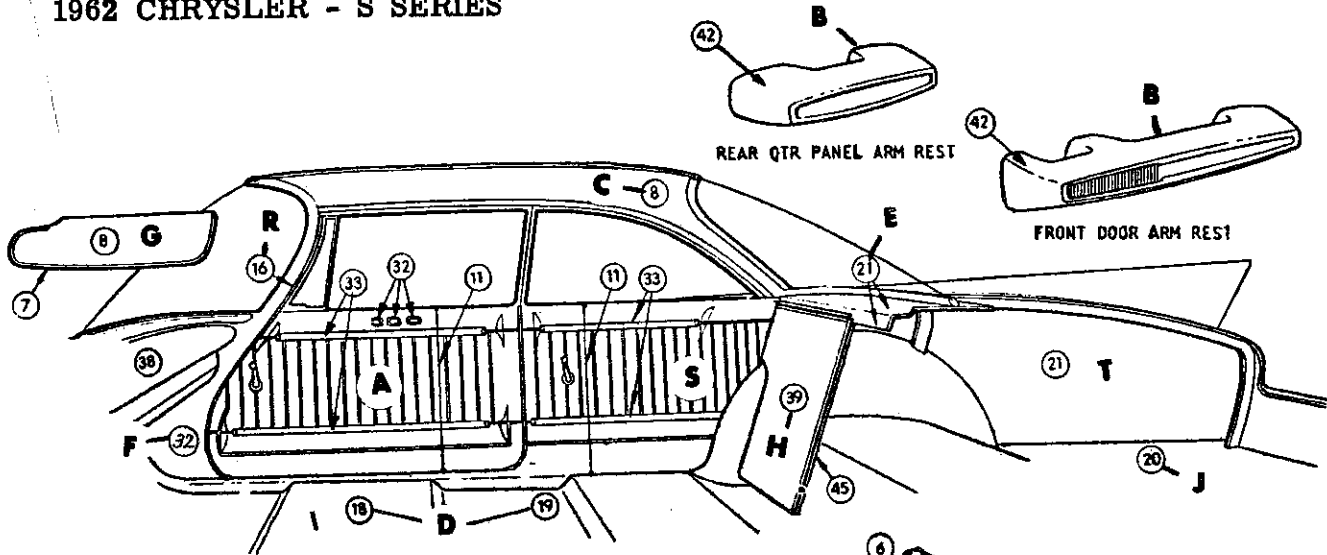

DISTRIBUTION OF MATERIAL

- 3 HEADLINING
- 4 LEATHER 1
- 5 LEATHER 2
- 6 IMITATION LEATHER 19-C-22
- 7 IMITATION LEATHER 19A-C-22
- 8 IMITATION LEATHER 12-Y-70
- 9 IMITATION LEATHER 19B-C-22
- 10 IMITATION LEATHER 28-AM-22
- 11 IMITATION LEATHER 19-DJ-22
- 16 LACE
- 17 EXTRUDED VINYL
- 18 FLOOR COVERING-FRONT-CARPET
- 19 FLOOR COVERING-REAR-CARPET
- 20 FLOOR COVERING-LUGG. COMPT, RUBBER
- 30 PLASTIC
- 31 PAINT
- 32 METAL
- 33 MOULDING
- 35 POLYETHYLENE
- 36 MYLAR
- 38 MOULDED RESIN
- 39 CARPET
- 41 FAN FLOCK
- 42 PLASTISOL
- 45 MASONITE

Distribution Drawing Legend Page Appears Following Illustration Section

Code 463

SCM-233A 1962 CHRYSLER SC2-M (300H) SPECIAL CLUB COUPE
LEATHER TRIM

1962 CHRYSLER - S SERIES

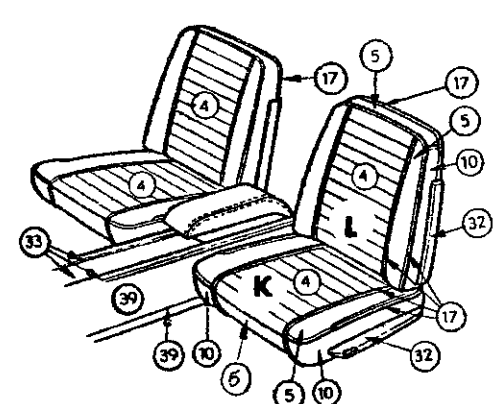
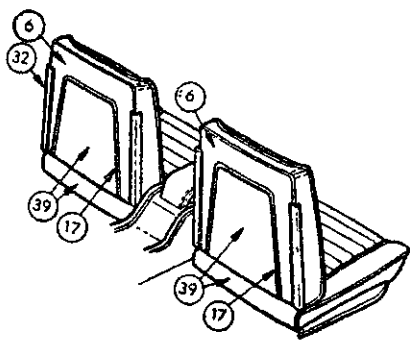
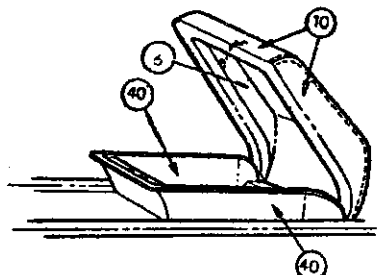
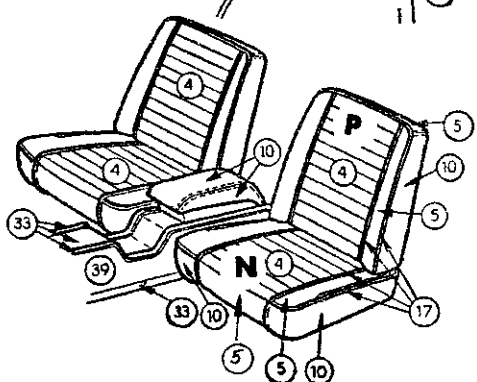
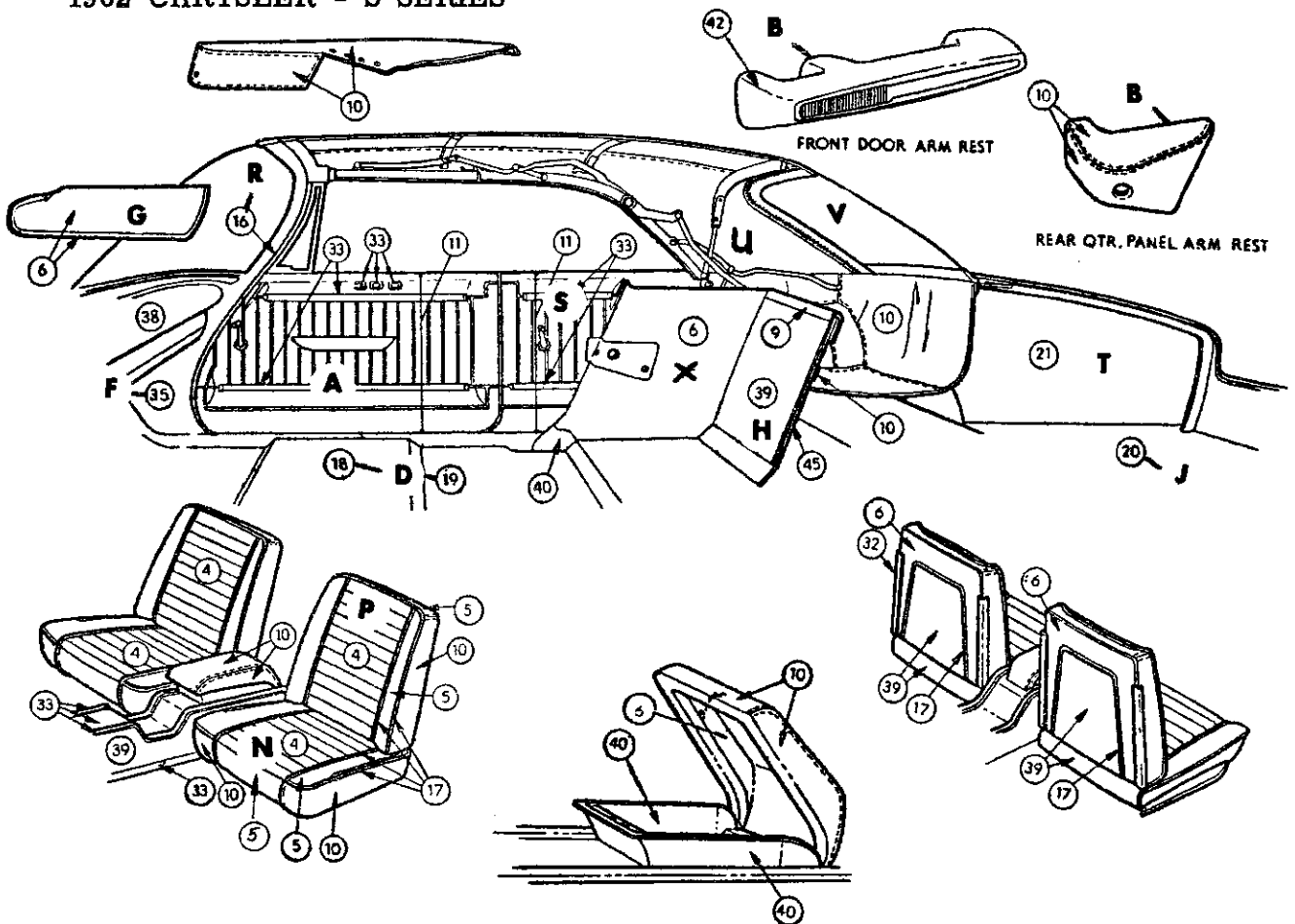

DISTRIBUTION OF MATERIAL

- 3 HEADLINING
- 4 LEATHER 1
- 5 LEATHER 2
- 6 IMITATION LEATHER 19-C-22
- 9 IMITATION LEATHER 19B-C-22
- 10 IMITATION LEATHER 28-AM-22
- 11 IMITATION LEATHER 19-DJ-22
- 16 LACE
- 17 EXTRUDED VINYL
- 18 FLOOR COVERING-FRONT-CARPET
- 19 FLOOR COVERING-REAR-CARPET
- 20 FLOOR COVERING-LUGG. COMPT. RUBBER
- 21 EMBOSSED CARDBOARD
- 26 FELT
- 30 PLASTIC
- 31 PAINT
- 32 METAL
- 33 MOULDING
- 35 POLYETHYLENE
- 36 MYLAR
- 38 MOULDED RESIN
- 39 CARPET
- 40 FAN FLOCK
- 42 PLASTISOL
- 45 PLYWOOD

Distribution Drawing Legend Page Appears Following Illustration Section

Code 463

SCM-273A 1962 CHRYSLER SC2-M (300H) CONVERTIBLE COUPE
LEATHER TRIM

1962 CHRYSLER - S SERIES

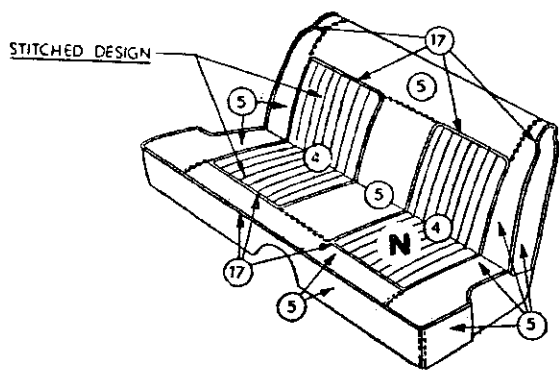
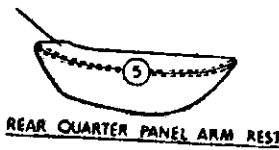
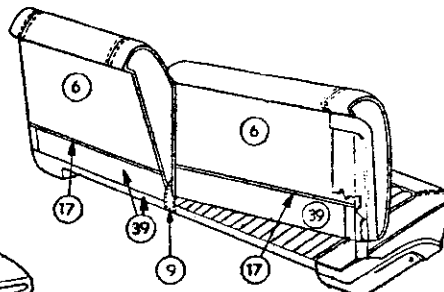
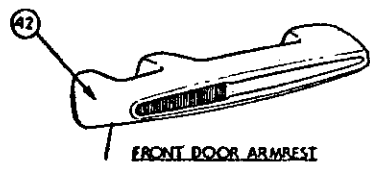
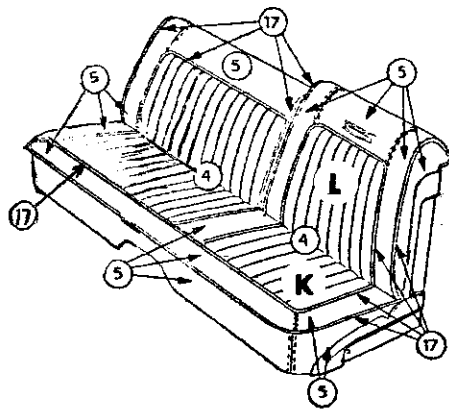
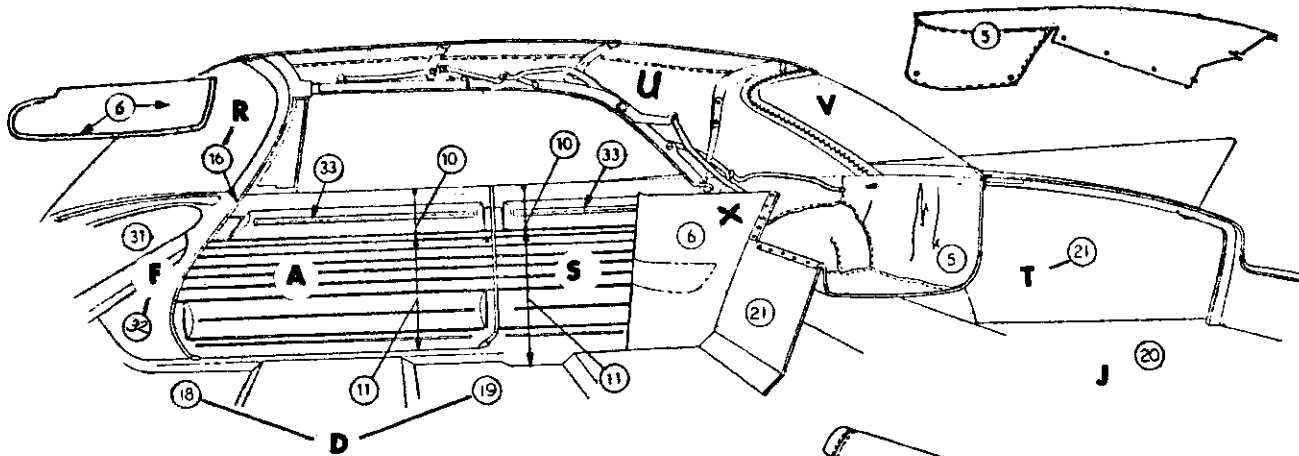

DISTRIBUTION OF MATERIAL

4	IMITATION LEATHER	28-AM-46
5	IMITATION LEATHER	28-AM-22
6	IMITATION LEATHER	19-C-22
9	IMITATION LEATHER	19B-C-22
10	IMITATION LEATHER	19-DJ-22
11	IMITATION LEATHER	.012-L-22
16	LACE	
17	EXTRUDED VINYL	
18	FLOOR COVERING-FRONT-RUBBER	
19	FLOOR COVERING-REAR-RUBBER	
20	FLOOR COVERING-LUGG, COMPT. RUBBER	
21	EMBOSSED CARDBOARD	
30	PLASTIC	
31	PAINT	
32	METAL	
33	MOULDING	
35	POLYETHYLENE	
36	MYLAR	
38	MOULDED RESIN	
39	CARPET	
42	PLASTISOL	

Distribution Drawing Legend Page Appears Following Illustration Section

Codes 401, 404, 405

SCL-274

1962 CHRYSLER SC1-L CONVERTIBLE COUPE
IMITATION LEATHER TRIM

1962 CHRYSLER - S SERIES

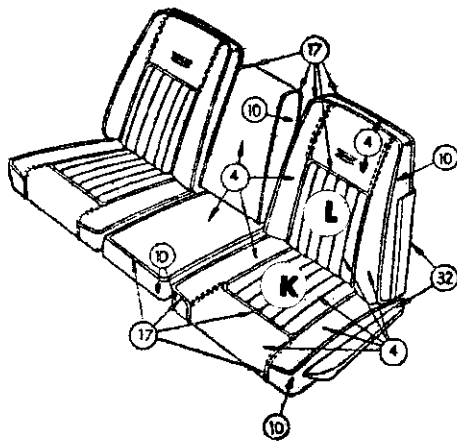
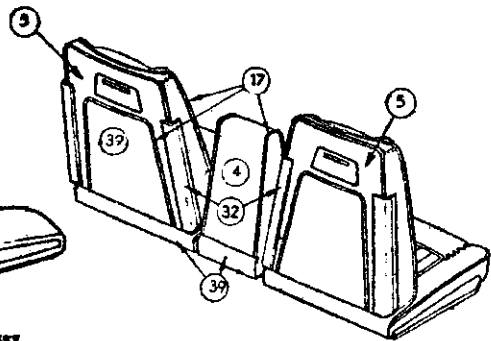
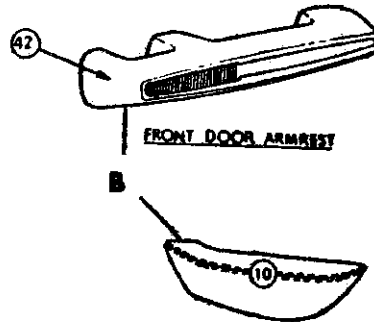
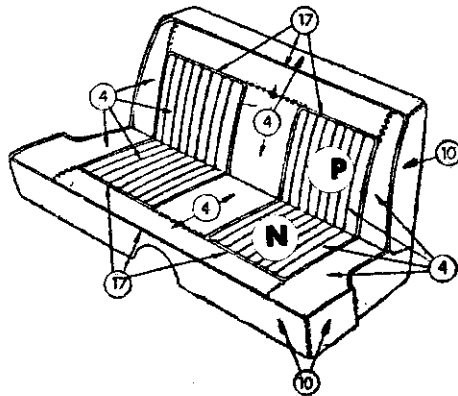
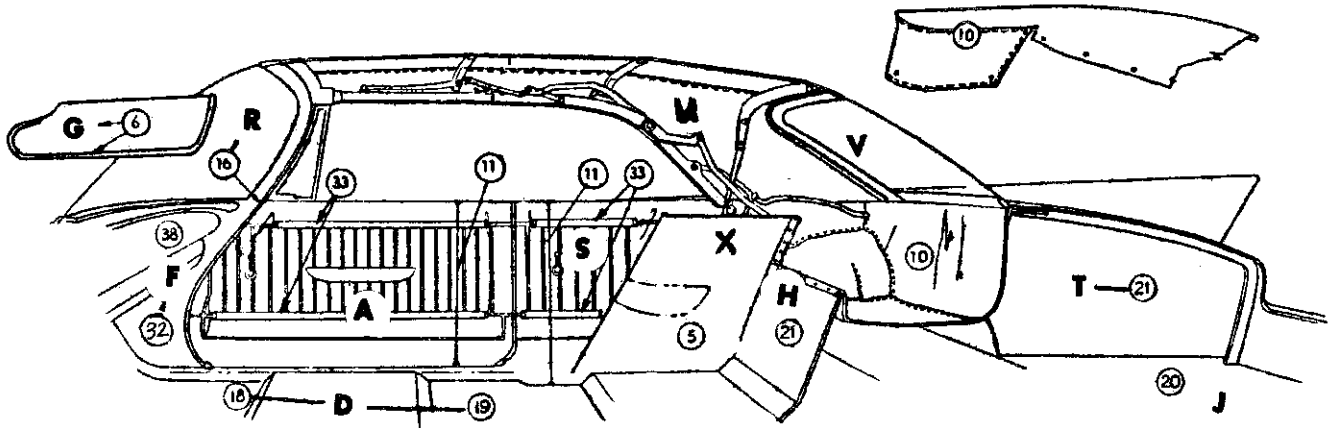

DISTRIBUTION OF MATERIAL

4	LEATHER	
5	IMITATION LEATHER	19-C-22
6	IMITATION LEATHER	19A-C-22
9	IMITATION LEATHER	19B-C-22
10	IMITATION LEATHER	28-AM-22
11	IMITATION LEATHER	19-DJ-22
16	LACE	
17	EXTRUDED VINYL	
18	FLOOR COVERING-FRONT-CARPET	
19	FLOOR COVERING-REAR-CARPET	
20	FLOOR COVERING-LUGG. COMPT. RUBBER	
21	EMBOSSED CARDBOARD	
30	PLASTIC	
31	PAINT	
32	METAL	
33	MOULDING	
35	POLYETHYLENE	
36	MYLAR	
38	MOULDED RESIN	
39	CARPET	
42	PLASTISOL	

Distribution Drawing Legend Page Appears Following Illustration Section

Codes 453, 454, 455

SCM-273

1962 CHRYSLER SC2-M CONVERTIBLE COUPE
LEATHER TRIM

1962 CHRYSLER AND IMPERIAL - S SERIES

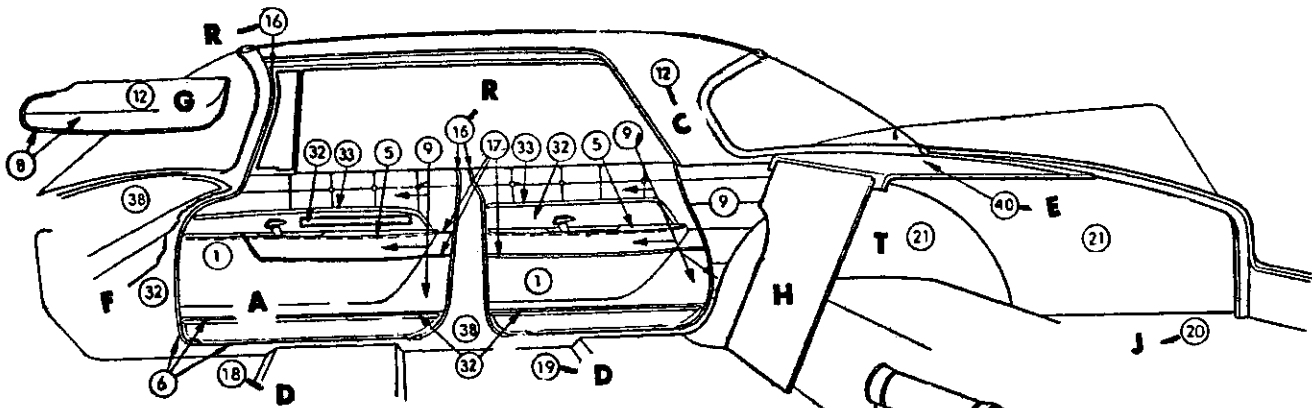

STITCHED DESIGN

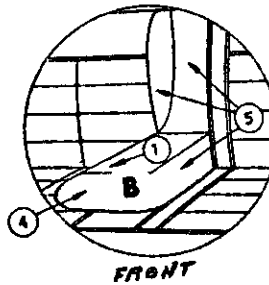
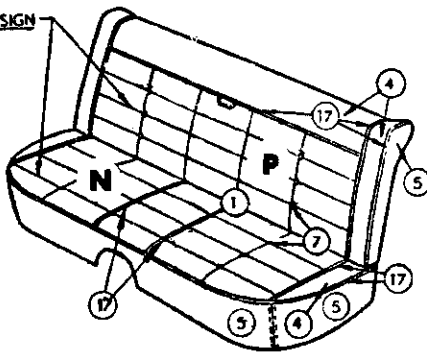

FRONT

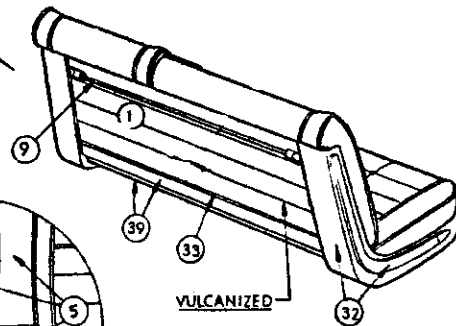

VULCANIZED

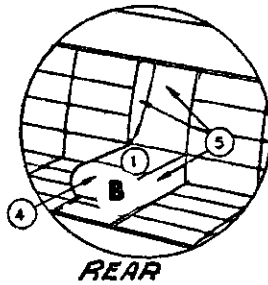

REAR

STITCHED DESIGN

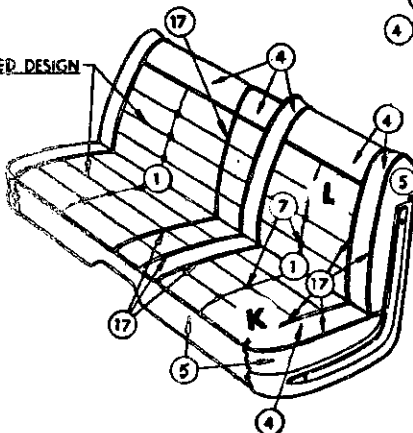

DISTRIBUTION OF MATERIAL

- 1 BODY CLOTH
- 4 LEATHER
- 5 IMITATION LEATHER 28-AM-22
- 6 IMITATION LEATHER 19-C-22
- 7 IMITATION LEATHER 19A-C-22
- 8 IMITATION LEATHER 19B-C-22
- 9 IMITATION LEATHER 22-AR-22
- 12 IMITATION LEATHER 19-C-5
- 16 LACE
- 17 EXTRUDED VINYL
- 18 FLOOR COVERING-FRONT-CARPET
- 19 FLOOR COVERING-REAR-CARPET
- 20 FLOOR COVERING-LUGG. COMPT. CARPET
- 21 EMBOSSED CARDBOARD
- 30 PLASTIC
- 31 PAINT
- 32 METAL
- 33 MOULDING
- 35 POLYETHYLENE
- 36 MYLAR
- 38 MOULDED RESIN
- 39 CARPET
- 40 WOVEN PAPER

Distribution Drawing Legend Page Appears Following Illustration Section

Codes 521, 522, 523, 524

SYH-435

1962 IMPERIAL SY1-H SPECIAL 4 DOOR SEDAN
CLOTH AND LEATHER TRIM

1962 CHRYSLER AND IMPERIAL - S SERIES

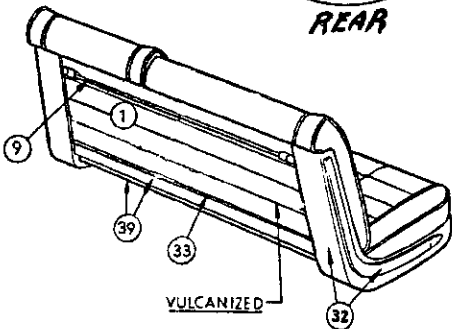
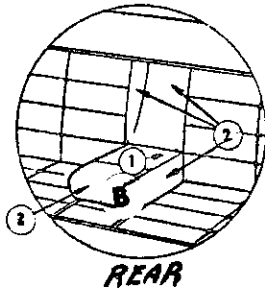
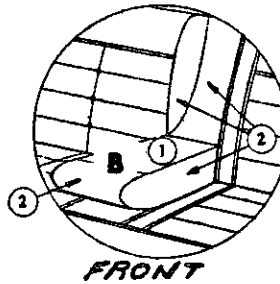
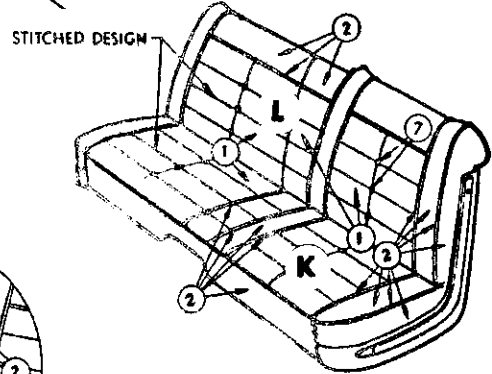
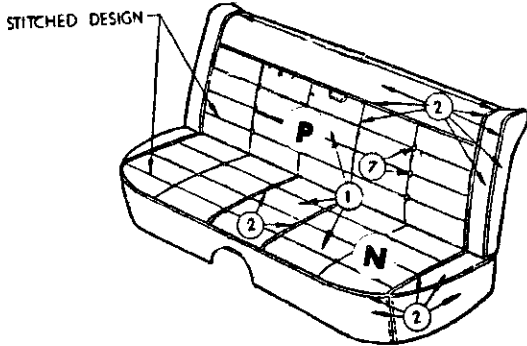
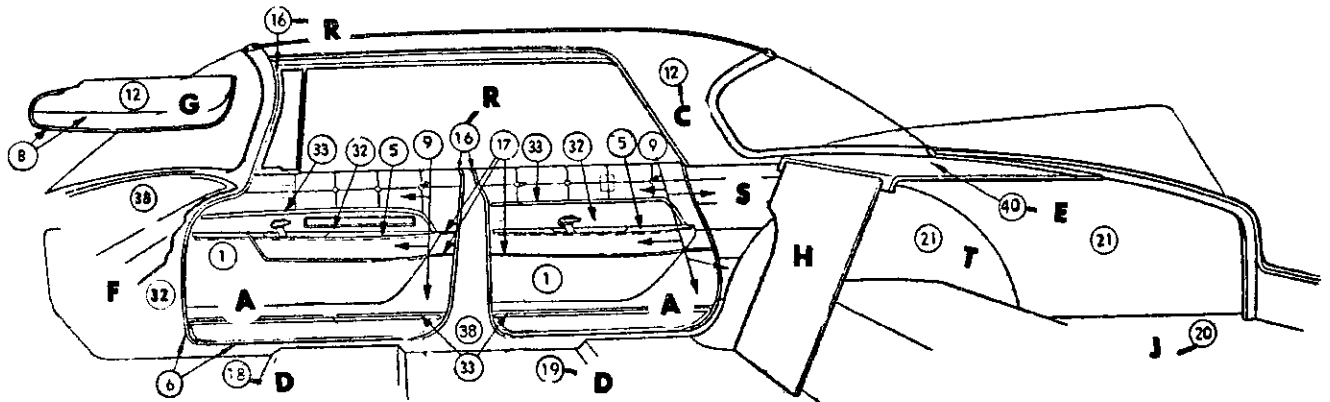

DISTRIBUTION OF MATERIAL

- 1 BODY CLOTH 1
- 2 BODY CLOTH 2
- 5 IMITATION LEATHER 28-AM-22
- 6 IMITATION LEATHER 19-C-22
- 7 IMITATION LEATHER 19A-C-22
- 8 IMITATION LEATHER 19B-C-22
- 9 IMITATION LEATHER 22-AR-22
- 12 IMITATION LEATHER 19-C-5
- 17 EXTRUDED VINYL
- 18 FLOOR COVERING-FRONT-CARPET
- 19 FLOOR COVERING-REAR-CARPET
- 20 FLOOR COVERING-LUGG. COMPT. CARPET
- 21 EMBOSSSED CARDBOARD
- 30 PLASTIC
- 31 PAINT
- 32 METAL
- 33 MOULDING
- 35 POLYETHYLENE
- 36 MYLAR
- 38 MOULDED RESIN
- 39 CARPET
- 40 WOVEN PAPER

Distribution Drawing Legend Page Appears Following Illustration Section

Code 534

SYH-432

1962 IMPERIAL SY1-H SPECIAL 4 DOOR SEDAN
CLOTH TRIM

1962 CHRYSLER AND IMPERIAL - S SERIES

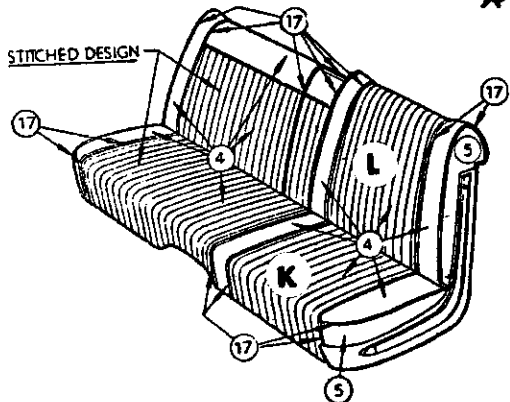
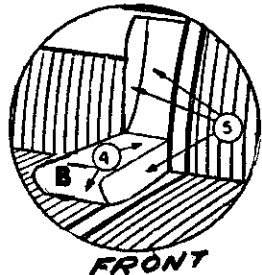
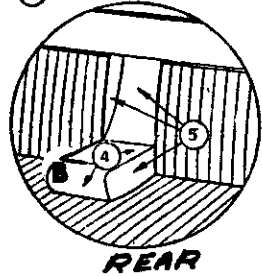
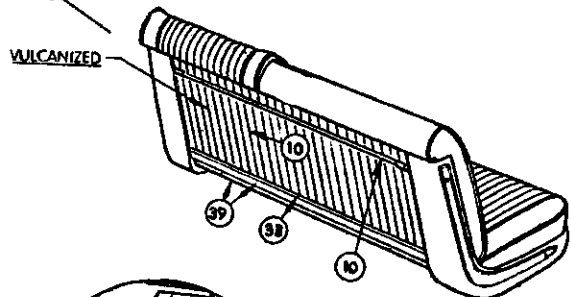
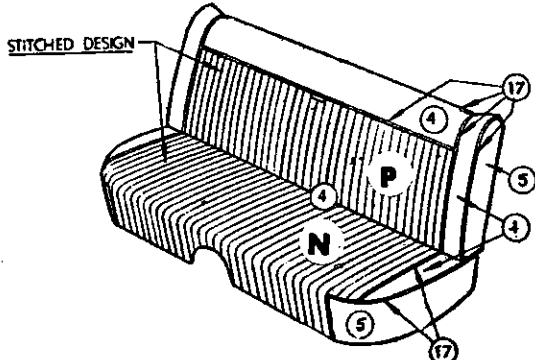
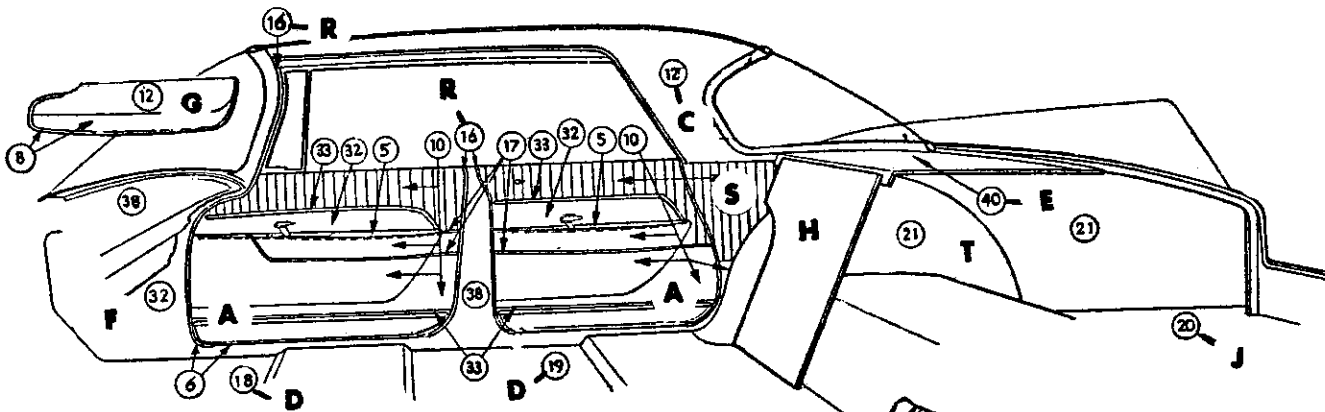

DISTRIBUTION OF MATERIAL

- 4 LEATHER
- 5 IMITATION LEATHER 28-AM-22
- 6 IMITATION LEATHER 19-C-22
- 8 IMITATION LEATHER 19B-C-22
- 10 IMITATION LEATHER 22-AR-22
- 12 IMITATION LEATHER 19-C-5
- 17 EXTRUDED VINYL
- 18 FLOOR COVERING-FRONT-CARPET
- 19 FLOOR COVERING-REAR-CARPET
- 20 FLOOR COVERING-LUGG. COMPT. CARPET
- 21 EMBOSSSED CARDBOARD
- 30 PLASTIC
- 31 PAINT
- 32 METAL
- 33 MOULDING
- 35 POLYETHYLENE
- 36 MYLAR
- 38 MOULDED RESIN
- 39 CARPET
- 40 WOVEN PAPER

Distribution Drawing Legend Page Appears Following Illustration Section

Codes 553, 555, 556, 557

SYM-433 1962 IMPERIAL SY1-M SPECIAL 4 DOOR SEDAN
LEATHER TRIM

1962 CHRYSLER AND IMPERIAL - S SERIES

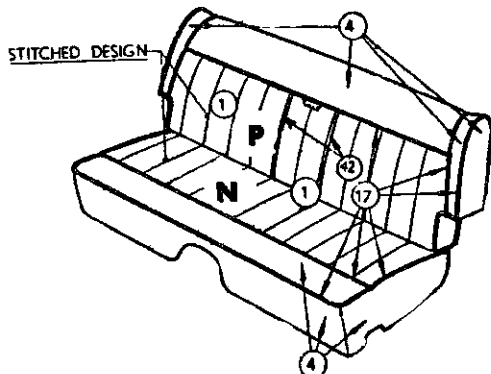
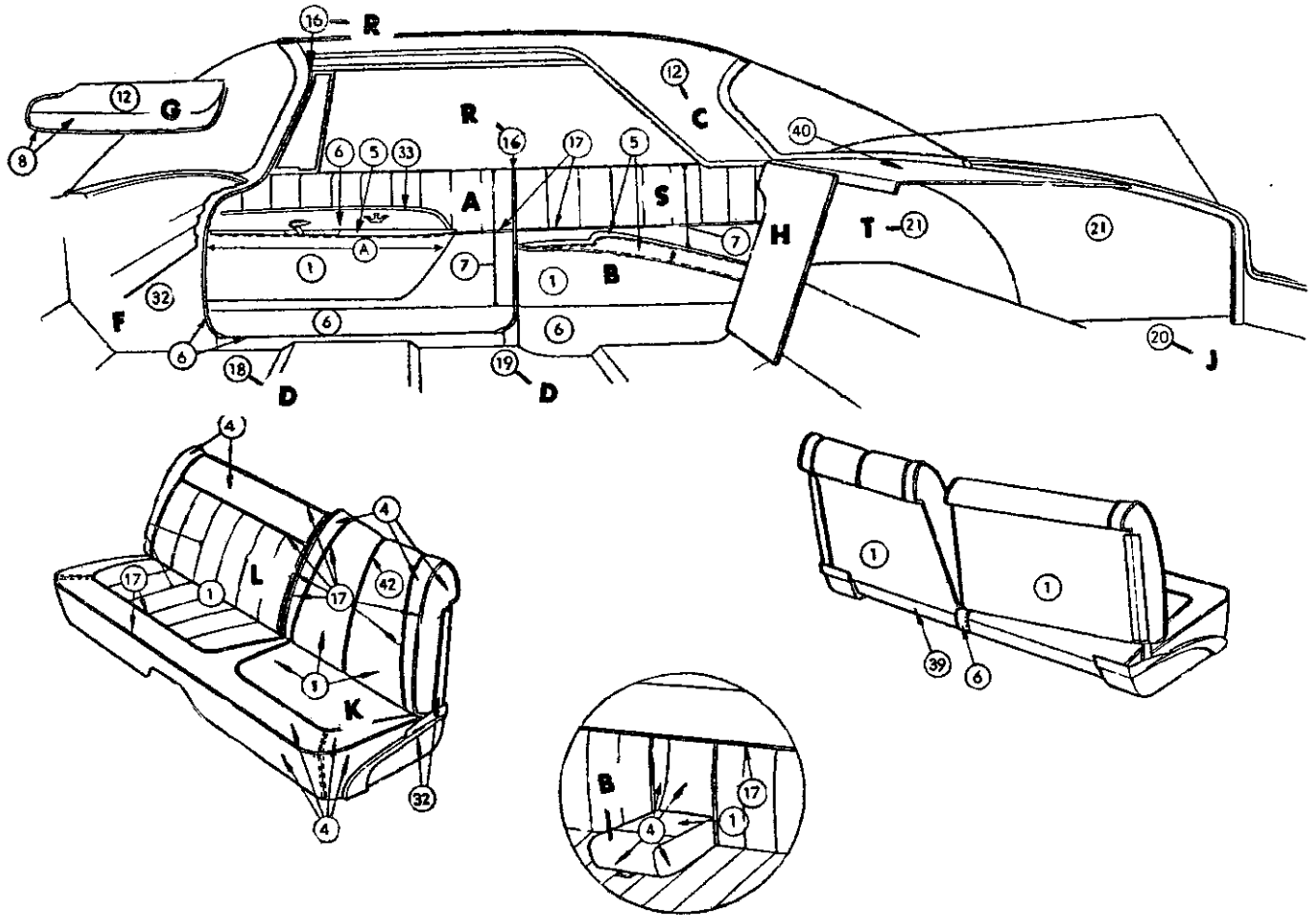

DISTRIBUTION OF MATERIAL

- 1 BODY CLOTH 1
- 4 IMITATION LEATHER 28-AM-22
- 5 IMITATION LEATHER 28A-AM-22
- 6 IMITATION LEATHER 19-C-22
- 7 IMITATION LEATHER 22-AR-22
- 8 IMITATION LEATHER 19B-C-22
- 12 IMITATION LEATHER 19-C-5
- 17 EXTRUDED VINYL WELT NO. 1
- 18 FLOOR COVERING-FRONT-CARPET
- 19 FLOOR COVERING-REAR-CARPET
- 20 FLOOR COVERING-LUGG. COMPT. CARPET
- 21 EMBOSSED CARDBOARD
- 30 PLASTIC
- 31 PAINT
- 32 METAL
- 33 MOULDING
- 35 POLYETHYLENE
- 36 MYLAR
- 38 MOULDED RESIN
- 39 CARPET
- 40 WOVEN PAPER
- 42 EXTRUDED VINYL WELT NO. 2

Distribution Drawing Legend Page Appears Following Illustration Section

Codes 501, 502, 503, 504

SYL-231

1962 IMPERIAL SY1-L SPECIAL CLUB COUPE
CLOTH AND IMITATION LEATHER COMBINATION

1962 CHRYSLER AND IMPERIAL - S SERIES

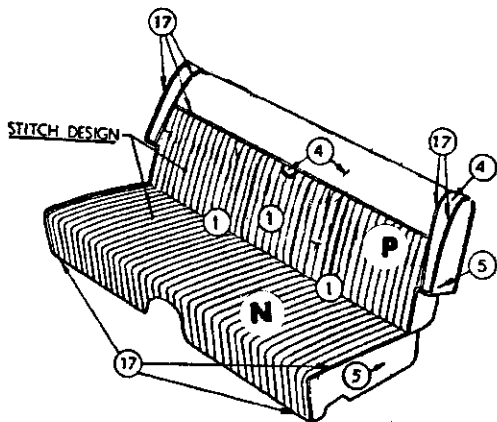
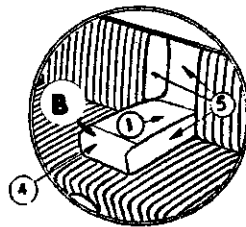
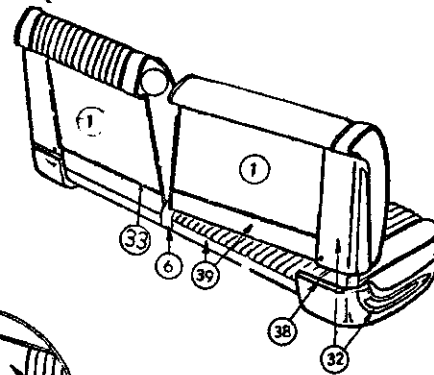
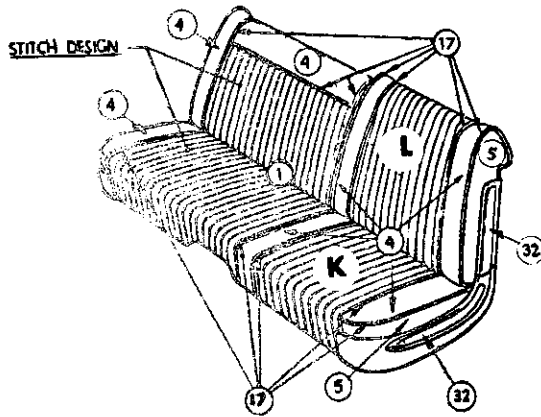
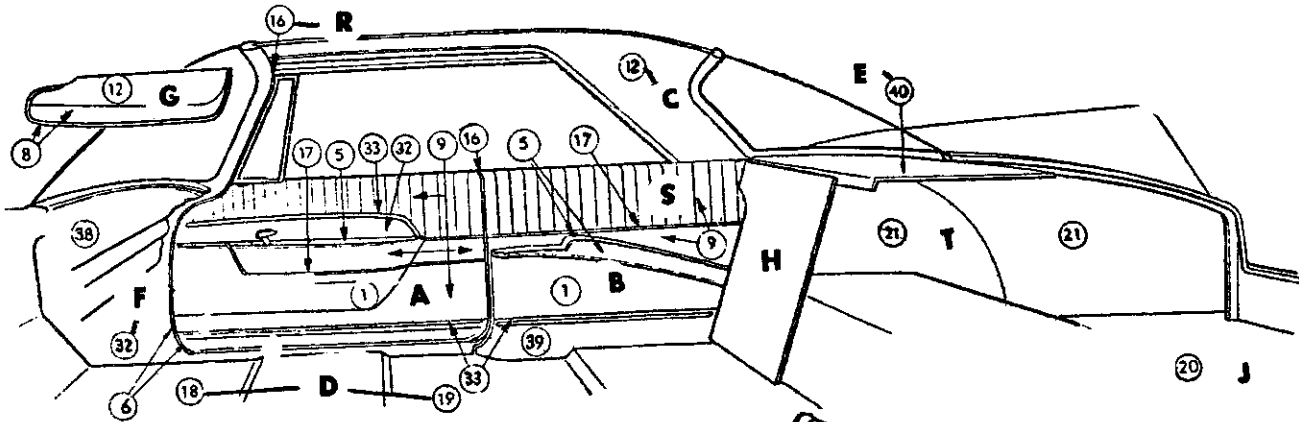

DISTRIBUTION OF MATERIAL

- 1 BODY CLOTH I
- 4 LEATHER
- 5 IMITATION LEATHER 28-AM-22
- 6 IMITATION LEATHER 19-C-22
- 8 IMITATION LEATHER 19B-C-22
- 9 IMITATION LEATHER 22-AR-22
- 12 IMITATION LEATHER 19-C-5
- 17 EXTRUDED VINYL
- 18 FLOOR COVERING-FRONT-CARPET
- 19 FLOOR COVERING-REAR-CARPET
- 20 FLOOR COVERING-LUGG. COMPT. CARPET
- 21 EMBOSSED CARDBOARD
- 30 PLASTIC
- 31 PAINT
- 32 METAL
- 33 MOULDING
- 35 POLYETHYLENE
- 36 MYLAR
- 38 MOULDED RESIN
- 39 CARPET
- 40 WOVEN PAPER

Distribution Drawing Legend Page Appears Following Illustration Section

Codes 511, 512, 513, 514, 515, 516

SYM-235

1962 IMPERIAL SY1-M SPECIAL CLUB COUPE
CLOTH AND LEATHER COMBINATION

1962 CHRYSLER AND IMPERIAL - S SERIES

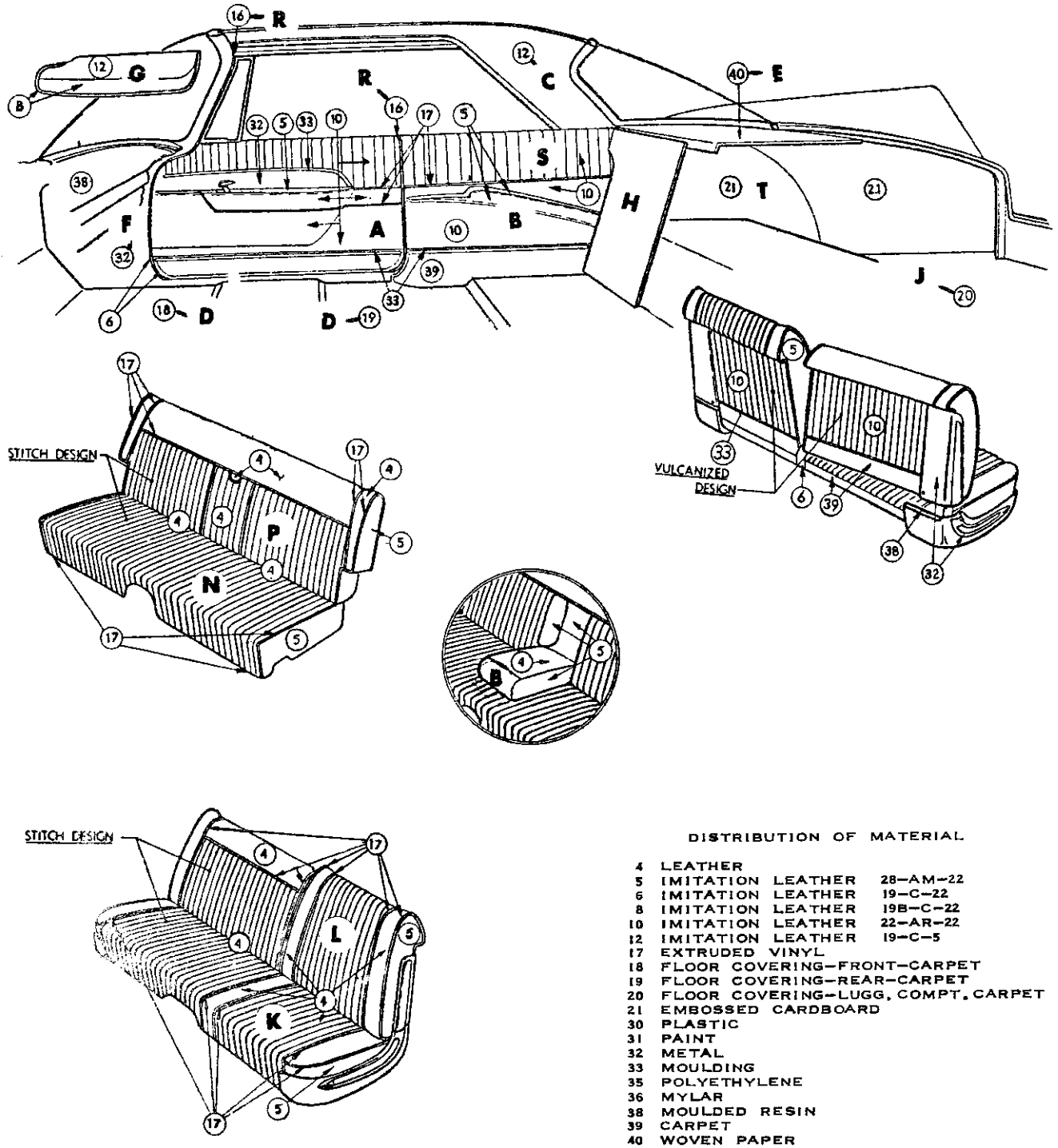

Distribution Drawing Legend Page Appears Following Illustration Section

Codes 553, 555, 556, 557

SYM-233

1962 IMPERIAL SY1-M SPECIAL CLUB COUPE
LEATHER TRIM

1962 CHRYSLER AND IMPERIAL - S SERIES

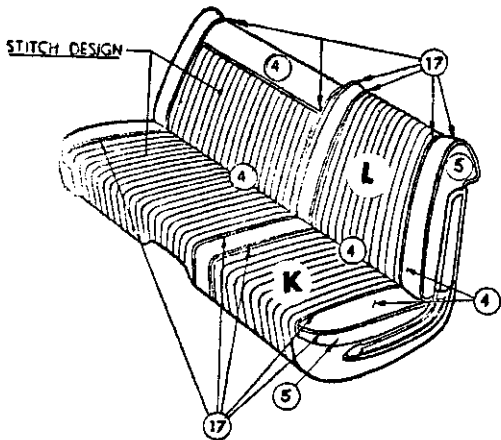
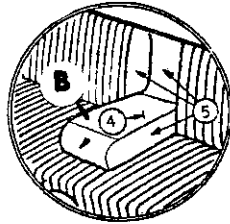
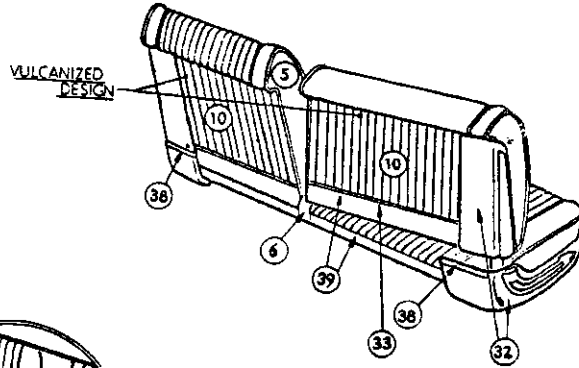
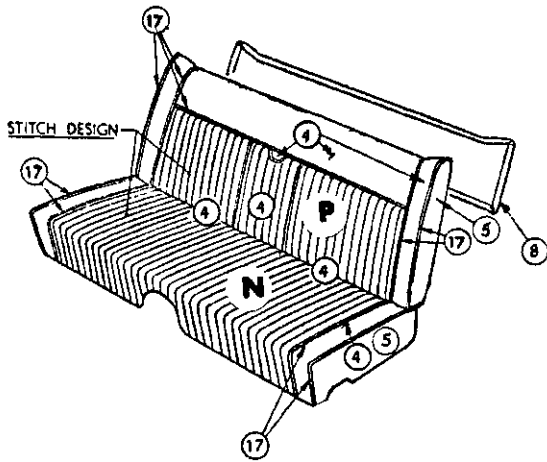
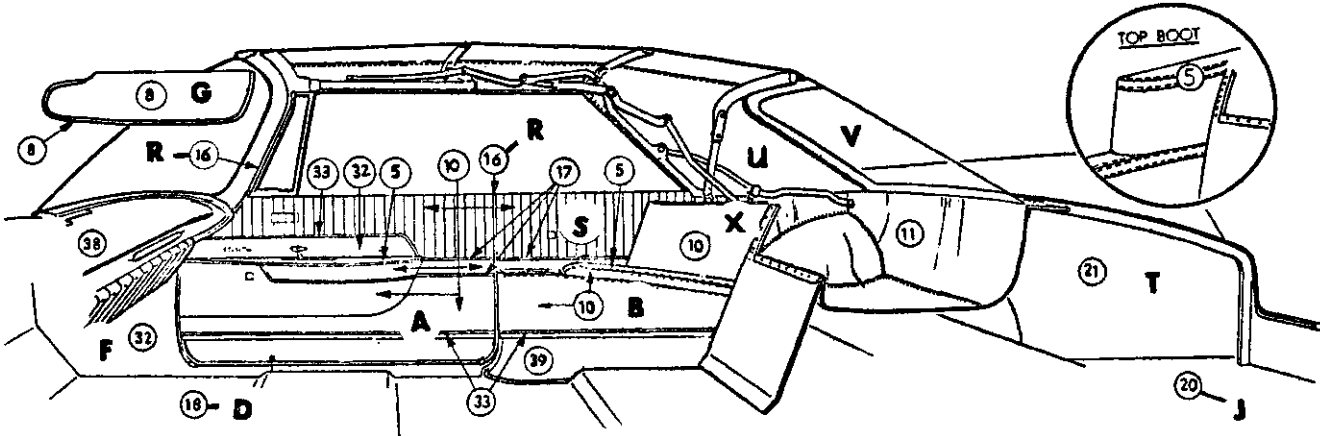

DISTRIBUTION OF MATERIAL

- 4 LEATHER
- 5 IMITATION LEATHER 28-AM-22
- 6 IMITATION LEATHER 19-C-22
- 8 IMITATION LEATHER 19C-C-22
- 10 IMITATION LEATHER 22-AR-22
- 11 IMITATION LEATHER 28A-AM-22
- 17 EXTRUDED VINYL
- 18 FLOOR COVERING-FRONT-CARPET
- 19 FLOOR COVERING-REAR-CARPET
- 20 FLOOR COVERING-LUGG. COMPT. CARPET
- 21 EMBOSSED CARDBOARD
- 30 PLASTIC
- 31 PAINT
- 32 METAL
- 33 MOULDING
- 36 MYLAR
- 38 MOULDED RESIN
- 39 CARPET

Distribution Drawing Legend Page Appears Following Illustration Section

Codes 553, 555, 556, 557

SYM-273

1962 IMPERIAL SY1-M CONVERTIBLE COUPE
LEATHER TRIM

1962 CHRYSLER & IMPERIAL - S SERIES

Distribution Drawing Legend

See Illustrations For Letter Identification

Letter	Description	Code
A	Panel, Door Trim	23-92-5
B	Arm Rest, Door, Front	23-76-3
	Center, Front Seat	23-76-34
	Center, Rear Seat	23-76-40
	Door, Rear	23-76-59
	Quarter Panel	23-76-66
C	Headlining	23-86-3
D	Floor Cover, Front, Carpet	23-79-3
	Rubber	23-20-8
	Rear, Carpet	23-79-33
	Rubber	23-20-41
E	Panel, Shelf Trim	23-102-3
F	Panel, Cowl Trim	23-91-6
G	Visor	23-103-3
H	Panel, Luggage Compartment, Front	23-96-3
J	Cover, Luggage Compartment Floor	23-20-29
K	Cover, Front Seat Cushion	23-108-5
L	Cover, Front Seat Back	23-108-16
M	Cover, Front Seat Hinge	23-108-84
N	Cover, Rear Seat Cushion	23-109-36
P	Cover, Rear Seat Back	23-109-4
Q	Cover, Rear Seat Cushion Bottom Panel	23-109-40
R	Weathercord, Door	23-113-2
	Hinge Pillar	23-113-25
	Lock Pillar	23-113-30
S	Panel, Quarter Trim	23-101-3
T	Cover, Wheelhouse	23-96-8
U	Top Deck & Side Quarter	23-112-108
V	Curtain, Folding Top Back	23-112-45
W	Cover, Center Pillar	23-99-4
X	Well, Pocket Panel, Pocket Panel Cover, Pocket Shelf Panel, Folding Top	23-112-153
Y	Cover, Tailgate Inside Panel	23-79-79
Z	Cover, Rear Seat Back Panel	23-109-5

BODY CODE

COLUMN LEGEND

NEWPORT (SC1-L)

812 (23)	2 D. Hard Top
813 (41)	4 D. Sedan
814 (43)	4 D. Hard Top
815 (27)	Convertible
858 (46)	Suburban (6 Pass.)
859 (46)	Suburban (9 Pass.)
893 (41)	4 D. Sedan (Police)
898 (45A)	Suburban (6 Pass.) (Police)

NEWPORT (300) (SC2-M)

822 (23)	2 D. Hard Top
824 (43)	4 D. Hard Top
825 (27)	Convertible

NEW YORKER (300-H) (SC2-M)

842 (23)	2 D. Hard Top
845 (27)	Convertible

NEW YORKER (SC3-H)

833 (41)	4 D. Sedan
834 (43)	4 D. Hard Top
878 (46)	Suburban (6 Pass.)
879 (46)	Suburban (9 Pass.)
893 (41)	4 D. Limousine
808 (46)	Ambulance

IMPERIAL (SY1-L)

912 (23)	2 D. Hard Top
914 (43)	4 D. Hard Top

CROWN IMPERIAL (SY1-M)

922 (23)	2 D. Hard Top
924 (43)	4 D. Hard Top
925 (27)	Convertible

LE BARON (SY1-H)

934 (43)	4 D. Hard Top
----------	---------------

CONVERTIBLE TOP COLOR LEGEND

1 Black

2 White

STARTING SERIAL NUMBERS

Detroit Built

SC1-L	(Newport)	8123-100001
SC1-L	(Newport Suburban)	8523-100001
SC2-M	(300)	8223-100001
SC2-M	(C300-H)	8423-100001
SC3-H	(New Yorker)	8323-100001
SC3-H	(New Yorker Suburban)	8723-100001
SY-1	(Imperial Custom)	9123-100001
SY-1	(Imperial Crown)	9223-100001
SY-1	(Imperial LeBaron)	9323-100001

★ Indicates use as required.

☐ Indicates parts not listed in any previous parts book.

Right and left part numbers are on same line, first number is right, second number is left.

* Indicates change or addition.

1962 PASSENGER CAR PARTS CATALOG

TRIM CODE	MODEL	MATERIAL			COLOR	S.D.	SP. 4D.	SUB.	SP. CL. CP.	CV. CP.
		Cloth	Vinyl	Leather						

TRIM CODES

301	C1-L	★	★	-	Blue	★	★	-	-	-
302	C1-L	★	★	-	Green (plaid)	★	★	-	★	-
303	C1-L	★	★	-	Cocoa	★	★	-	-	-
304	C1-L	★	★	-	Gray and Black	★	★	-	-	-
305	C1-L	★	★	-	Red	★	★	-	-	-
308	C1-L	★	★	-	Turquoise (plaid)	★	★	-	★	-
313	C2-M	★	★	-	Tan	-	★	-	-	-
314	C2-M	★	★	-	Gray and Black	-	★	-	-	-
315	C2-M	★	★	-	Red	-	★	-	-	-
331	C3-H	★	★	-	Blue	★	★	-	-	-
333	C3-H	★	★	-	Cocoa	★	★	-	-	-
334	C3-H	★	★	-	Gray	★	★	-	-	-
335	C3-H	★	★	-	Red	★	★	-	-	-
341	C1-L	★	★	-	Blue	★	★	-	★	-
343	C1-L	★	★	-	Cocoa	★	★	-	★	-
344	C1-L	★	★	-	Gray and Black	★	★	-	★	-
345	C1-L	★	★	-	Red	★	★	-	★	-
401	C1-L	-	★	-	Blue	-	-	-	-	★
403	C1-L	-	★	-	Cocoa	-	-	-	★	-
404	C1-L	-	★	-	Black	-	★	-	★	★
405	C1-L	-	★	-	Red	-	-	-	★	★
413	C2-M	-	★	-	Gold	-	★	-	-	-
414	C2-M	-	★	-	Black	-	★	-	-	-
415	C2-M	-	★	-	Red	-	★	-	-	-
423	C3-H	-	★	-	Cocoa	-	-	★	-	-
424	C3-H	-	★	-	Black	-	-	★	-	-
425	C3-H	-	★	-	Red	-	-	★	-	★
444	C1-L, C3-H	-	★	-	Gray	★	-	-	-	-
453	C2-M	-	-	★	Gold	-	★	-	★	★
454	C2-M	-	-	★	Black	-	★	-	★	★
455	C2-M	-	-	★	Red	-	★	-	★	★
463	C2-M	-	-	★	Tan	-	-	-	★	★
464	C3-H	-	★	-	Black	-	★	-	★	-
465	C3-H	-	★	-	Red	-	★	-	★	-
501	Y1-L	★	★	-	Blue	-	★	-	★	-
502	Y1-L	★	★	-	Green	-	★	-	★	-
503	Y1-L	★	★	-	Cordovan	-	★	-	★	-
504	Y1-L	★	★	-	Gray	-	★	-	★	-
511	Y1-M	★	-	★	Blue	-	★	-	★	-
512	Y1-M	★	-	★	Green	-	★	-	★	-
513	Y1-M	★	-	★	Cordovan	-	★	-	★	-
514	Y1-M	★	-	★	Gray	-	★	-	★	-
515	Y1-M	★	-	★	Red	-	★	-	★	-
516	Y1-M	★	-	★	Black	-	★	-	★	-
553	Y1-M	-	-	★	Tan	-	★	-	★	★
555	Y1-M	-	-	★	Red	-	★	-	★	★
556	Y1-M	-	-	★	Black	-	★	-	★	★
557	Y1-M	-	-	★	Off White	-	★	-	★	★
521	Y1-H	★	-	★	Black	-	★	-	-	-
522	Y1-H	★	-	★	Green	-	★	-	-	-
523	Y1-H	★	-	★	Cocoa	-	★	-	-	-
524	Y1-H	★	-	★	Gray	-	★	-	-	-
534	Y1-H	★	-	★	Gray	-	★	-	-	-
565	Y1-H	-	-	★	Red	-	★	-	-	-
567	Y1-H	-	-	★	White	-	★	-	-	-

★ Indicates use as required.

☐ Indicates parts not listed in any previous parts book.

March 8, 1963 Supersedes May 1, 1962.

CODE	REMARKS	PER CAR	SED.	SP. 4 D.	SUB.	SP. CL. CP.	CV. CP.
------	---------	---------	------	----------	------	-------------	---------

NOTE: RIGHT HAND AND LEFT HAND PARTS LISTED ON THE SAME LINE. Whenever right and left hand parts are identified by consecutive part numbers, they will be listed as in the following example: PANEL, Door Trim 2083 344-5
 Interpreted, this indicates that Panel, right is Part No. 2083 344 and Panel, left is Part No. 2083 345.

23-70-5	COVER, Wheelhouse Second Seat Back Hinge Bracket						
	C1-L, C3-H (codes 404, 424)	1	----	----	2169 991-2		
	(codes 405, 425)	1	----	----	2178 332-3		
	(codes 403, 423)	1	----	----	2178 611-2		
23-70-6	HINGE, Second Seat Back C1, C3	1	----	----	2094 882-3		
23-71-1	COVER, Floor Tunnel Console C2-M	Frnt.	1	----	----	2132 692-3	2132 692-3
		Rr.	1	----	----	2132 695-6	2132 695-6
23-76-3	ARM REST, Front Door						
	C1-L, C2-M (codes 301, 341, 401)	1	*2273 006-7	*2273 006-7	----	*2273 006-7	
	(codes 303, 343, 403)	1	*2273 010-1	*2273 010-1	*2273 010-1	*2273 010-1	
	(codes 304, 344, 444)	1	*2273 012-3	*2273 012-3	*2273 012-3	*2273 012-3	*2273 012-3
	(codes 305, 315, 345, 405, 415, 425, 455)	1	*2273 014-5	*2273 014-5	*2273 014-5	*2273 014-5	*2273 014-5
	(codes 313, 413, 453, 463)	1	----	2178 840-1	----	2178 840-1	2178 840-1
	(codes 302, 308, 314, 404, 414, 424, 454)	1	*2177 818-9	2177 818-9	2177 818-9	2177 818-9	2177 818-9
	C3-H (code 331)	1	2178 312-3	2178 312-3			
	(code 333)	1	2178 314-5	2178 314-5			
	(code 334)	1	2178 316-7	2178 316-7			
	(code 335)	1	2178 318-9	2178 318-9			
(code 423) (Police and Fleet)	1	----	----	*2273 010-1			
(code 423)	1	----	----	2178 324-5			
(codes 424, 464)	1	----	2178 322-3	2178 322-3			
(codes 425, 465)	1	2178 320-1	2178 320-1	2178 320-1			
Screw	4	162 090	162 090	162 090			
23-76-5	PULL, Door Arm Rest C3-H Y1	1	2080 114-5	2080 114-5	2080 114-5		
		1	----	2085 660-1	----	2085 660-1	2085 660-1
23-76-7	BRACKET, Front Door Arm Rest Support C3-H	2	2086 210	2086 210	2086 210		
23-76-16	NUT, Door and Quarter Panel Arm Rest Attaching C1, C2, C3	4	1280 134	1280 134	1280 134	1280 134	1280 134
23-76-18	ARM REST, Front Seat Back Center						
	C2-M (code 453)	1	----	----	----	2132 482	2132 482
	(code 454)	1	----	----	----	2132 483	2132 483
	(code 455)	1	----	----	----	2132 484	2132 484
	Y1-M (code 511)	1	----	2149 150			
	(code 512)	1	----	2149 151			
	(code 513)	1	----	2149 152			
	(code 514)	1	----	2149 153			
	(code 515)	1	----	2149 154			
	(code 516)	1	----	2149 155			
	(code 553)	1	----	2149 156			
	(codes 555, 565)	1	----	2149 157			
	(code 556)	1	----	2149 158			
	(codes 557, 567)	1	----	2149 159			

★ Indicates use as required.

☐ Indicates parts not listed in any previous parts book.

Right and left part numbers are on same line, first number is right, second number is left.

* Indicates change or addition.

1962 PASSENGER CAR PARTS CATALOG

INTERIOR TRIM

CODE	REMARKS	PER CAR	SED.	SP. 4D.	SUB.	SP. CL. CP.	CV. CP.
23-76-18	ARM REST, Front Seat Back Center - Cont'd						
	Y1-H (code 521)	1	----	2149 899			
	(code 522)	1	----	2149 330			
	(code 523)	1	----	2149 331			
	(code 524)	1	----	2149 332			
	(code 534)	1	----	2149 329			
23-76-19	FLAP, Front Seat Back Center Arm Rest						
	Y1-M, Y1-H (codes 511, 521)	1	----	2149 132			
	(codes 512, 522)	1	----	2149 133			
	(codes 513, 523)	1	----	2149 134			
	(codes 514, 524)	1	----	2149 135			
	(codes 515, 555, 565)	1	----	2149 136			
	(codes 516, 556)	1	----	2149 137			
	Y1-M (code 553)	1	----	2149 138			
	(codes 557, 567)	1	----	2149 139			
	Y1-H (code 534)	1	----	2149 322			
23-76-27	HOOK, Front Seat Center Arm Rest Frame						
	C2-M	1	----	----	----	1918 568	1918 568
23-76-34	COVER, Front Seat Back Center Arm Rest						
	C2-M (code 453)	1	----	----	----	2132 492	2132 492
	(code 454)	1	----	----	----	2132 493	2132 493
	(code 455)	1	----	----	----	2132 494	2132 494
	Y1-M (code 511)	1	----	2149 140			
	(code 512)	1	----	2149 141			
	(code 513)	1	----	2149 142			
	(code 514)	1	----	2149 143			
	(code 515)	1	----	2149 144			
	(code 516)	1	----	2149 145			
	(code 553)	1	----	2149 146			
	(codes 555, 565)	1	----	2149 147			
	(code 556)	1	----	2149 148			
	(codes 557, 567)	1	----	2149 149			
	Y1-H (code 521)	1	----	2149 903			
	(code 522)	1	----	2149 325			
	(code 523)	1	----	2149 326			
	(code 524)	1	----	2149 327			
	(code 534)	1	----	2149 324			
23-76-40	ARM REST, Rear Seat Back Center						
	C3-H (codes 321, 331)	1	2132 032	2132 032			
	(code 334)	1	2132 034	2132 034			
	(code 333)	1	2132 033	2132 033			
	(code 335)	1	2132 273	2132 273			
	(code 464)	1	----	*2132 753			
	(code 465)	1	----	*2132 128			
	Y1-L (code 501)	1	----	2148 647	----	2148 647	
	(code 502)	1	----	2148 648	----	2148 648	
	(code 503)	1	----	2148 649	----	2148 649	
	(code 504)	1	----	2148 650	----	2148 650	
	Y1-M (code 511)	1	----	2149 016	----	2149 016	
	(code 512)	1	----	2149 017	----	2149 017	
	(code 513)	1	----	2149 018	----	2149 018	
	(code 514)	1	----	2149 019	----	2149 019	
	(code 515)	1	----	2149 020	----	2149 020	
	(code 516)	1	----	2149 021	----	2149 021	
	(code 553)	1	----	2149 022	----	2149 022	2149 022

★ Indicates use as required.

E Indicates parts not listed in any previous parts book.
May 1, 1962 Supersedes Nov. 30, 1961.

Page IT-154

Printed in U.S.A.

Prices and specifications subject to change without notice.
Right and left part numbers are on same line,
first number is right, second number is left.

* Indicates change or addition.

CODE	REMARKS	PER CAR	SED.	SP. 4 D.	SUB.	SP. CL. CP.	CV. CP.
23-76-40	ARM REST, Rear Seat Back Center - Cont'd Y1-M (codes 555, 565) (code 556) (codes 557, 567) Y1-H (code 521) (code 522) (code 523) (code 524) (code 534)	1 1 1 1 1 1 1 1	---- ---- ---- ---- ---- ---- ---- ----	2149 023 2149 024 2149 025 2149 907 2149 283 2149 284 2149 285 2149 282	---- ---- ---- ---- ---- ---- ---- ----	2149 023 2149 024 2149 025	2149 023 2149 024 2149 025
23-76-45	COVER, Rear Seat Back Center Arm Rest C3-H (code 331) (code 333) (code 334) (code 335) (code 464) (code 465) Y1-L (code 501) (code 502) (code 503) (code 504)	1 1 1 1 1 1 1 1 1 1	2132 035 2132 036 2132 037 2132 310 ---- ---- ---- ---- ---- ----	2132 035 2132 036 2132 037 2132 310 *2132 754 2132 129 2148 643 2148 644 2148 645 2148 646	---- ---- ---- ---- ---- ---- ---- ---- ---- ----	2148 643 2148 644 2148 645 2148 646	
	Y1-M (code 511) (code 512) (code 513) (code 514) (code 515) (code 516) (code 553) (codes 555, 565) (code 556) (codes 557, 567)	1 1 1 1 1 1 1 1 1 1	---- ---- ---- ---- ---- ---- ---- ---- ---- ----	2149 006 2149 007 2149 008 2149 009 2149 010 2149 011 2149 012 2149 013 2149 014 2149 015	---- ---- ---- ---- ---- ---- ---- ---- ---- ----	2149 006 2149 007 2149 008 2149 009 2149 010 2149 011 2149 012 2149 013 2149 014 2149 015	2149 012 2149 013 2149 014 2149 015
	Y1-H (code 521) (code 522) (code 523) (code 524) (code 534)	1 1 1 1 1	---- ---- ---- ---- ----	2149 910 2149 278 2149 279 2149 280 2149 277	---- ---- ---- ---- ----		
23-76-53	FLAP, Rear Seat Back Center Arm Rest C3-H (code 331) (code 333) (code 334) (code 335) (code 464) (code 465)	1 1 1 1 1 1	2132 038 2132 039 2132 040 2132 319 ---- ----	2132 038 2132 039 2132 040 2132 319 *2132 755 *2131 730	---- ---- ---- ---- ---- ----		
	Y1-L, Y1-M, Y1-H (codes 501, 511, 521) (codes 502, 512, 522) (codes 504, 514, 524) (codes 503, 513, 523, 553) (codes 515, 555, 565) (codes 516, 556) (codes 557, 567)	1 1 1 1 1 1 1	---- ---- ---- ---- ---- ---- ----	2148 659 2148 660 2148 662 2148 661 2148 663 2148 664 2148 665	---- ---- ---- ---- ---- ---- ----	2148 659 2148 660 2148 662 2148 661 2148 663 2148 664 2148 665	2148 661 2148 663 2148 664 2148 665
23-76-57	FRAME, Rear Seat Back Center Arm Rest C3 Y1	1 1	2160 640 ----	2160 640 2160 576	---- ----	2160 576	2160 578

★ Indicates use as required.

□ Indicates parts not listed in any previous parts book.

Right and left part numbers are on same line,

first number is right, second number is left.

* Indicates change or addition.

CODE	REMARKS	PER CAR	SED.	SP. 4 D.	SUB.	SP. CL. CP.	CV. CP.
23-76-59	ARM REST, Rear Door C1-L, C2-M (codes 301, 341, 401) (codes 303, 343, 403, 423) (codes 304, 344, 444) (codes 305, 315, 345, 405, 415) (codes 313, 413) (tan) (codes 302, 304, 308, 314, 404, 414, 424, 454) (code 423) (Police and Fleet)	1 1 1 1 1 1 1 1	*2273 006-7 *2273 010-1 *2273 012-3 *2273 014-5 ---- ---- ---- ----	*2273 006-7 *2273 010-1 *2273 012-3 *2273 014-5 2178 840-1 *2177 818-9 ---- ----		*2273 014-5 *2177 818-9 *2178 324-5 *2273 010-1	
	C3-H (code 333) (codes 424, 464) (codes 425, 465)	1 1 1	2178 314-5 ---- ----	2178 314-5 2178 322-3 2178 320-1			
23-76-64	SUPPORT and BRACKET, Door Arm Rest Y1	1	----	2241 234-5			
23-76-66	ARM REST, Rear Quarter C1-L, C2-M (codes 301, 341) (codes 303, 343) (codes 304, 344) (codes 302, 308, 314, 404) (codes 305, 315, 345, 405, 455) (codes 313, 453, 463) (code 454)	2 2 2 2 2 2 2	---- ---- ---- ---- ---- ---- ----	---- ---- ---- ---- ---- ---- ----		*2273 000 *2273 002 *2273 003 *2083 862 *2273 004 2178 839 2083 862	
	C1-L, C2-M (code 401) (codes 404, 454) (codes 405, 455) (code 453)	1 1 1 1	---- ---- ---- ----	---- ---- ---- ----		---- ---- ---- ----	2132 110-1 2132 112-3 2132 114-5 2132 352-3
	Y1-L (code 501) (code 502) (code 503) (code 504)	1 1 1 1	---- ---- ---- ----	---- ---- ---- ----		2148 722-3 2148 724-5 2148 726-7 2148 728-9	
	Y1-M (code 511) (code 512) (code 513) (code 514) (code 515) (code 516) (code 553) (code 555) (code 556) (code 557)	1 1 1 1 1 1 1 1 1 1	---- ---- ---- ---- ---- ---- ---- ---- ---- ----	---- ---- ---- ---- ---- ---- ---- ---- ---- ----		2148 950-1 2148 952-3 2148 954-5 2148 956-7 2148 958-9 2148 960-1 2148 970-1 2148 972-3 2148 974-5 2148 976-7	2149 064-5 2149 066-7 2149 068-9 2149 070-1
23-76-79	SUPPORT, Quarter Panel Arm Rest Y1	1	----	----		1751 534-5	1751 534-5
23-76-80	NUT, Quarter Trim Panel Arm Rest to Quarter Panel C1, C2	4	----	----		1280 134	
23-76-86	COVER, Rear Quarter Arm Rest C1-L, C2-M (code 401) (code 453) (codes 404, 454) (codes 405, 455)	1 1 1 1	---- ---- ---- ----	---- ---- ---- ----		---- ---- ---- ----	2132 116-7 2132 404-5 2132 118-9 2132 120-1
	Y1-L (code 501) (code 502) (code 503) (code 504)	1 1 1 1	---- ---- ---- ----	---- ---- ---- ----		2148 714-5 2148 716-7 2148 718-9 2148 720-1	
	Y1-M (code 511) (code 512) (code 513)	1 1 1	---- ---- ----	---- ---- ----		2148 938-9 2148 940-1 2148 942-3	

★ Indicates use as required.

□ Indicates parts not listed in any previous parts book.
March 8, 1963 Supersedes May 1, 1962.Prices and specifications subject to change without notice.
Right and left part numbers are on same line,
first number is right, second number is left.
* Indicates change or addition.

CODE	REMARKS	PER CAR	SED.	SP. 4 D.	SUB.	SP. CL. CP.	CV. CP.
23-76-86	COVER, Rear Quarter Arm Rest - Cont'd Y1-M (code 514) (code 515) (code 516) (code 553) (code 555) (code 556) (code 557)	1 1 1 1 1 1 1	---- ---- ---- ---- ---- ---- ----	---- ---- ---- ---- ---- ---- ----	---- ---- ---- ---- ---- ---- ----	2148 944-5 2148 946-7 2148 948-9 2148 962-3 2148 964-5 2148 966-7 2148 968-9	2149 056-7 2149 058-9 2149 060-1 2149 062-3
23-76-106	ARM REST, Floor Tunnel Console C2-M Frt. Rr.	1 1	---- ----	---- ----	---- ----	2132 697 2132 709	2132 697 2132 709
23-76-107	COVER, Floor Tunnel Console Arm Rest C2-M (inside upper)	2 2	---- ----	---- ----	---- ----	2132 698 2132 699	2132 698 2132 699
23-78-2	BUTTONS, Tufting Y1-M (luggage compartment) (light gray) (dark gray)	2 2	---- ----	---- ----	---- ----	---- ----	2175 539 2178 205
23-79-3	CARPET, Front Floor C1-L, C2-M, C3-H (codes 301, 321, 331, 341, 401) (blue) (codes 303, 333, 403) (cordovan) (codes 302, 304, 308, 313, 314, 334, 344, 345, 404, 405, 413, 414, 415, 423, 424, 425, 453, 454, 455, 464, 465) (black) (code 463) (tan)	1 1 1 1 1	*2177 015 2177 016 *2177 017 ----	*2177 015 2177 016 *2177 017 ----	---- *2177 016 *2177 017 ----	*2177 015 2177 016 *2177 017 2178 366	*2177 015 2178 366
	Y1-L (code 501) (blue) (code 502) (green) (code 503) (cordovan) (code 504) (black) Y1-M, Y1-H (codes 511, 531) (blue) (codes 512, 522) (green) (codes 513, 523) (cordovan) (code 553) (tan) (codes 515, 555) (red) (codes 514, 516, 524, 534, 556, 557, 567) (black)	1 1 1 1 1 1 1 1 1 1	---- ---- ---- ---- ---- ---- ---- ---- ---- ----	2177 786 2177 787 2177 788 2177 789 2177 794 2177 795 2177 796 2177 799 2177 798 *2177 797	---- ---- ---- ---- ---- ---- ---- ---- ---- ----	2177 786 2177 787 2177 788 2177 789 2177 794 2177 795 2177 796 2177 799 2177 798 *2177 797	 2177 799 2177 798 *2177 797
23-79-33	CARPET, Rear Floor C1-L, C2-M, C3-H (codes 301, 321, 331, 341) (blue) (codes 303, 333, 343, 403, 423) (cordovan) (codes 302, 304, 305, 308, 313, 314, 315, 334, 344, 345, 404, 405, 414, 415, 424, 425, 453, 454, 455, 464, 465) (black) (code 463) (tan)	1 1 1 1	*2176 669 *2176 670 *2175 494 ----	*2176 669 *2176 670 *2175 494 ----	---- *2178 617 *2211 837 ----	*2176 673 *2176 674 *2175 494 *2178 367	*2176 673 *2175 494 *2178 367
	C1-L, C3-H (codes 403, 404, 405)(axle kick-up rear panel) (rear floor pan cover insert) (center seat to rear floor pan insert)	1 1 1	---- ---- ----	---- ---- ----	2169 953 2169 951 2169 950		

★ Indicates use as required.

□ Indicates parts not listed in any previous parts book.
Right and left part numbers are on same line,
first number is right, second number is left.

* Indicates change or addition.

CODE	REMARKS	PER CAR	SED.	SP. 4 D.	SUB.	SP. CL. CP.	CV. CP.
23-79-33	CARPET, Rear Floor - Cont'd C1-L, C3-H (codes 423, 424, 425)(police, ambulance and limo.) (rear floor pan cover insert)	1	----	----	2169 951		
	(second seat rear floor pan insert)	1	----	----	2169 950		
	(codes 403, 423) (spare tire compartment floor)	1	----	----	*2178 619		
	(spare tire compartment well riser)	1	----	----	2178 184-5		
	(rear floor pan insert)	1	----	----	2178 639		
	(axle kick-up rear panel)	1	----	----	2178 648		
	(codes 424, 425) (spare tire compartment)	1	----	----	2176 098		
	(spare tire compartment well riser)	1	----	----	2173 023-4		
	(rear floor pan insert)	1	----	----	*2176 437		
	(axle kick-up rear panel)	1	----	----	2176 097		
Y1-L (code 501)	(blue)	1	----	2177 868	----	2177 874	
(code 502)	(green)	1	----	2177 869	----	2177 875	
(code 503)	(cordovan)	1	----	2177 870	----	2177 876	
(code 504)	(black)	1	----	2177 841	----	2177 851	
Y1-M, Y1-H (codes 511, 531)	(blue)	1	----	2177 880	----	2177 885	
(codes 512, 522)	(green)	1	----	2177 881	----	2177 886	
(codes 513, 523)	(cordovan)	1	----	2177 882	----	2177 887	
(code 553)	(tan)	1	----	2177 884	----	2177 889	2177 893
(codes 514, 516, 524, 534, 556, 557, 567)	(black)	1	----	*2177 861	----	*2177 866	*2177 891
(codes 515, 555)	(red)	1	----	2177 883	----	2177 888	*2177 888
23-79-62	INSERT, Second Seat Cushion Panel C1-L, C3-H (codes 403, 404, 405) (gray)	1	----	----	2169 946		
	(codes 423, 424, 425) (police, ambulance and limo.)	1	----	----	2169 946		
	(codes 424, 425) (black)	1	----	----	2176 436		
	(code 423) (cordovan)	1	----	----	2178 634		
23-79-64	CARPET, Luggage Compartment Floor Y1 (one piece)	1	----	*2149 775	----	*2149 775	*2149 776
	(two pieces) Rt.	1	----	*2295 580	----	*2295 580	*2295 580
	Lt.	1	----	*2295 581	----	*2295 581	*2295 581
	(spare tire cover)	1	----	2149 774	----		
	(deck opening lower cover)	1	----	*2178 207	----	*2178 207	*2178 207
23-79-77	PANEL, Wheelhouse Inner C1-L, C3-H (code 404) (black)	1	----	----	2169 553-4		
	(code 405) (upper)	1	----	----	2177 004-5		
	(code 423) (cordovan)	1	----	----	2178 653-4		
	(code 424) (black)	1	----	----	2176 998-9		
	(code 425) (black)	1	----	----	2177 000-1		
	(w/ledge cover) (code 423)	1	----	----	2132 566-7		
23-79-79	INSERT, Tailgate Inside Panel C1-L, C3-H (codes 403, 404, 405) (codes 423, 424, 425) (police, ambulance and limo.)	1	----	----	2169 952		
	(codes 424, 425)	1	----	----	2169 952		
	(code 423) (cordovan)	1	----	----	2176 438		
		1	----	----	2176 640		

★ Indicates use as required.

☐ Indicates parts not listed in any previous parts book.
March 8, 1963 Supersedes May 1, 1962.Prices and specifications subject to change without notice.
Right and left part numbers are on same line,
first number is right, second number is left.

* Indicates change or addition.

CODE	REMARKS	PER CAR	SED.	SP. 4 D.	SUB.	SP. CL. CP.	CV. CP.
23-82-3	STRAP, Front Seat Back Robe Y1-L, Y1-M, Y1-H (codes 501, 511, 521) (blue) (codes 502, 512, 522) (green) (codes 503, 513, 523) (cocoa) (codes 504, 514, 534) (gray) (code 553) (tan) (codes 515, 555, 565) (red) (code 557, 567) (white) (codes 516, 556) (black)	1 1 1 1 1 1 1 1 1 1	---- ---- ---- ---- ---- ---- ---- ---- ---- ----	2177 486 2177 487 2177 488 2177 489 2177 491 2177 490 2177 492 2175 769			
23-82-5	COVER, Front Seat Back Robe Strap End Y1	1	----	2080 727			
23-82-6	BOLT, Strap, Front Seat Back Robe Strap Y1	1	----	2080 824			
23-82-30	HOOK, Coat Hanger C1, C2 Y1	2 2	2165 837 ----	2165 837 1520 791	2165 837 ----	2165 837 1520 791	
23-82-39	BRACKET, Coat Hook Support C1, C2 (soft headlining) (hard headlining)	2 2	---- 1964 072	1963 287	----	1963 287	
23-84-3	PAD, Instrument Panel Trim C1-L, C2-M, C3-H (codes 301, 331, 341, 401) (blue) (codes 303, 333, 343, 403, 423) (cocoa) (codes 313, 353, 413, 453, 463) (gold) (codes 302, 304, 305, 308, 314, 315, 334, 335, 344, 345, 404, 405, 414, 415, 424, 425, 444, 454, 455, 464, 465)(black) (also specify 7 of 6008 222 fasteners)	1 1 1 1	*2177 624 *2177 625 2178 842 *2174 883	*2177 624 *2177 625 2178 842 *2174 883	*2177 624 *2177 625 2178 842 *2174 883	*2177 624 *2177 625 2178 842 *2174 883	*2177 624 *2177 625 2178 842 *2174 883
	Y1 (codes 501, 511, 521) (blue)(upper) (lower center) (lower right) (glove box door) (instruments housing) (ash receiver door) (heater control housing) (gear selector housing)	1 1 1 1 1 1 1 1	---- ---- ---- ---- ---- ---- ---- ----	2177 992 2177 997 2178 007 2178 017 2178 027 2178 037 2178 047 2178 057	---- ---- ---- ---- ---- ---- ---- ----	2177 992 2177 997 2178 007 2178 017 2178 027 2178 037 2178 047 2178 057	
	(codes 502, 512, 522) (green) (upper) (lower center) (lower right) (glove box door) (instruments housing) (ash receiver door) (heater control housing) (gear selector housing) (codes 503, 513, 523) (cordovan) upper (lower center) (lower right)	1 1 1 1 1 1 1 1 1 1 1 1	---- ---- ---- ---- ---- ---- ---- ---- ---- ---- ---- ----	2177 993 2177 998 2178 008 2178 018 2178 028 2178 038 2178 048 2178 058 2177 994 2177 999 2178 009	---- ---- ---- ---- ---- ---- ---- ---- ---- ---- ---- ----	2177 993 2177 998 2178 008 2178 018 2178 028 2178 038 2178 048 2178 058 2177 994 2177 999 2178 009	

★ Indicates use as required.
 ☐ Indicates parts not listed in any previous parts book.
 Right and left part numbers are on same line,
 first number is right, second number is left.
 * Indicates change or addition.

1962 PASSENGER CAR PARTS CATALOG

CODE	REMARKS	PER CAR	SED.	SP. 4 D.	SUB.	SP. CL. CP.	CV. CP.
23-84-3	PAD, Instrument Panel Trim - Cont'd Y1 (codes 503, 513, 523) (glove box door)(cordovan) (instruments housing) (ash receiver door) (heater control housing) (gear selector housing)	1 1 1 1 1	---- ---- ---- ---- ----	2178 019 2178 029 2178 039 2178 049 2178 059	---- ---- ---- ---- ----	2178 019 2178 029 2178 039 2178 049 2178 059	
	(codes 504, 514, 516, 524, 534, 556, 557, 567) (black) (upper) (lower center) (lower right) (glove box door) (instruments housing) (ash receiver) (heater control housing) (gear selector housing)	1 1 1 1 1 1 1 1	---- ---- ---- ---- ---- ---- ---- ----	2172 299 2172 311 2172 347 2172 335 2172 359 2172 323 2174 684 2174 672	---- ---- ---- ---- ---- ---- ---- ----	2172 299 2172 311 2172 347 2172 335 2172 359 2172 323 2174 684 2174 672	
	(codes 515, 555, 565) (red) (upper) (lower center) (lower right) (glove box door) Y1 (codes 515, 555, 565)(red) (instruments housing) (ash receiver housing) (heater control housing) (gear selector housing)	1 1 1 1 1 1 1 1 1	---- ---- ---- ---- ---- ---- ---- ---- ----	2177 995 2178 000 2178 010 2178 020 2178 030 2178 040 2178 050 2178 060	---- ---- ---- ---- ---- ---- ---- ----	2177 995 2178 000 2178 010 2178 020 2178 030 2178 040 2178 050 2178 060	2177 995 2178 000 2178 010 2178 020
	(code 553) (tan) (upper) (lower center) (lower right) (glove box door) (instruments housing) (ash receiver housing) (heater control housing) (gear selector housing)	1 1 1 1 1 1 1 1	---- ---- ---- ---- ---- ---- ---- ----	2177 996 2178 001 2178 011 2178 021 2178 031 2178 041 2178 051 2178 061	---- ---- ---- ---- ---- ---- ---- ----	2177 996 2178 001 2178 011 2178 021 2178 031 2178 041 2178 051 2178 061	2177 996 2178 001 2178 011 2178 021 2178 031 2178 041 2178 051 2178 061
23-84-30	CUSHION, Steering Wheel Horn Ring C1, C2, C3 (codes 301, 331, 341, 401) (blue) (codes 303, 333, 343, 413, 453) (tan) (codes 304, 334, 344, 404, 414, 424, 454) (black) (codes 305, 315, 335, 345, 405, 415, 425, 455, 465) (red) (saddle tan)	2 2 2 2 1	*2265 326 *2265 328 *2265 327 *2265 329 2266 718	*2265 326 *2265 328 *2265 327 *2265 329 2266 718	*2265 326 *2265 328 *2265 327 *2265 329 2266 718	*2265 326 *2265 328 *2265 327 *2265 329 2266 718	*2265 326 *2265 328 *2265 327 *2265 329 2266 718
	Y1 (codes 501, 511, 531)(blue) (codes 502, 512, 522)(green) (codes 503, 513, 523)(cordovan) (codes 504, 514, 524, 534, 556, 557, 567) (black) (code 553) (tan) (codes 555, 557)	1 1 1 1 1 1	---- ---- ---- ---- ---- ----	2260 970 2260 971 2260 972 *2201 602 2260 973 2260 974	---- ---- ---- ---- ---- ----	2260 970 2260 971 2260 972 *2201 602 2260 973 2260 974	2260 970 2260 971 2260 972 *2201 602 2260 973 2260 974
23-84-31	RETAINER and ORNAMENT, Steering Wheel Cushion Y1 (cushion base)	1 1	---- ----	2200 587 2200 586	---- ----	2200 587 2200 586	2200 587 2200 586

★ Indicates use as required.
 □ Indicates parts not listed in any previous parts book.
 March 8, 1963 Supersedes May 1, 1962.

Prices and specifications subject to change without notice.
 Right and left part numbers are on same line,
 first number is right, second number is left.

* Indicates change or addition.

CODE	REMARKS	PER CAR	SED.	SP. 4 D.	SUB.	SP. CL. CP.	CV. CP.
23-86-3	HEADLINING and LISTING						
	C1-L, C3-H						
	(codes 301, 331, 341)	1	*2132 632	*2132 645			
	(code 302)						
	(low back light)	1	2144 259	2144 271			
	(high back light)	1	----	*2144 263	----	2144 267	
	(codes 303, 333, 343)	1	*2132 633	*2132 646			
	(codes 304, 334, 344, 444)	1	*2132 634				
	(codes 305, 335, 345)	1	*2132 198				
	(code 308)						
	(low back light)	1	2144 260	2144 272			
	(high back light)	1	----	2144 364	----	2144 268	
	C2-M (codes 313, 413, 453)	1	----	*2132 647			
	(codes 314, 404, 414, 454)	1	----	*2132 648			
	(codes 315, 345, 405, 415)	1	----	*2132 649			
	C1-L, C2-M, C3-H (large rear window)(codes 301, 331)	1	----	2132 680			
	(codes 303, 333)	1	----	2132 681			
	(codes 313, 413)	1	----	2132 682			
	(codes 304, 314, 334, 404, 414, 464)	1	----	2132 683			
	(codes 305, 315, 335, 405, 415, 455, 465)	1	----	2132 684			
	C1-L, C3-H (codes 403, 404, 405, 423, 424, 425) (white)						
	(No. 1)	1	----	----	*2180 950		
	(No. 2)	1	----	----	2176 826		
	(No. 3)	1	----	----	*2180 840		
	(No. 4)	1	----	----	2176 828		
	(No. 5)	1	----	----	2176 829		
	(No. 6)	1	----	----	2176 830		
	(No. 7)	1	----	----	2176 831		
	C1-L, C2-M (code 301)	1	----	----	----	2132 661	
	(code 303)	1	----	----	----	2132 662	
	(codes 313, 453, 463)	1	----	----	----	*2132 665	
	(codes 304, 314, 454, 464)	1	----	----	----	*2132 663	
	(codes 305, 315, 405, 455)	1	----	----	----	2132 664	
	(retaining clip)	2	----	----	6000 373		
	Y1-L, Y1-M (codes 501, 511)	1	----	2149 855			
	(codes 502, 512)	1	----	2149 856			
	(codes 503, 513)	1	----	2149 857			
	(codes 504, 514, 516, 556)	1	----	2149 858			
	(code 553)	1	----	2149 860			
	(codes 515, 555)	1	----	2149 859			
	(code 557)	1	----	2149 861			
	(code 565)	1	----	2149 912			
	(code 567)	1	----	2149 913			
	Y1-H (code 521)	1	----	2149 883			
	(code 522)	1	----	2149 884			
	(code 523)	1	----	2149 885			
	(codes 524, 534)	1	----	2149 886			
	(code 565)	1	----	2149 912			
	(code 567)	1	----	2149 913			
	Y1-L, Y1-M (codes 501, 511)	1	----	----	----	2149 869	
	(codes 502, 512)	1	----	----	----	2149 870	
	(codes 503, 513)	1	----	----	----	2149 871	
	(codes 504, 514, 516, 556)	1	----	----	----	2149 872	
	(code 553)	1	----	----	----	2149 874	
	(codes 515, 555)	1	----	----	----	2149 873	
	(code 557)	1	----	----	----	2149 875	

★ Indicates use as required.

☐ Indicates parts not listed in any previous parts book.

Right and left part numbers are on same line, first number is right, second number is left.

* Indicates change or addition.

CODE	REMARKS	PER CAR	SED.	SP. 4 D.	SUB.	SP. CL. CP.	CV. CP.
23-86-6	SUPPORT, Rear Window Frame to Rear Headlining Listing Wire No. 6 Y1-L, Y1-M	2	----	1961 348			
23-86-10	SUPPORT, Roof Bow C1, C2 (steel) (No. 1) (No. 2) (No. 2) (w/dome lamp housing) (No. 3 & 4)	1 1 1 1	1954 682 ---- 1963 606 ----	1954 682 ---- 1963 606 ----	1954 682 1961 243 ---- 1961 244	1954 682 2162 219	
23-86-11	RETAINER, Headlining Bow to Support Y1	12	----	6006 071	----	6006 071	
23-86-13	FILLER, Air Conditioning Evaporating Unit Trim C1, C3 (gray)	2	----		1914 582		
23-86-14	PAD, Air Conditioning Evaporating Unit Trim C1, C3 (gray)	1	----		2171 580		
23-86-15	PANEL, Under Rear Window Y1-H (code 521) (code 522) (code 523) (codes 524, 534) (code 565) (code 567)	1 1 1 1 1 1	----	2149 891 2149 771 2149 772 2149 773 2149 916 2149 917			
23-86-19	STRIP, Roof Headlining Retaining C1, C2 (low window) Y1 (side rail, frt.) (shelf panel) (up to) (44 1/2" lgh.) (after) (46" lgh.)	1 1 1 2 2	1954 804-5 ---- ----	1961 656-7 2080 958-9 *2255 336 *2217 910	---- ---- ---- ----	1961 656-7 *2255 336 *2217 910	
23-86-24	RETAINER, Roof Inside Finish Panel C1-L, C3-H (No. 1) (No. 2) (No. 3) (No. 4) (No. 5) (No. 6) Y1 (windshield header)	1 1 1 1 1 1 1	----	----	2086 143 2086 142 2086 145 2086 146 2086 146 2086 148 2088 680-1		
23-86-35	MOULDING, Roof Inside Finish Panel C1, C2, C3 (headlining bow) (No. 1) (No. 2) (No. 3) C1, C3 (finish panel) (chrome) (Nos. 1, 2, 3, 4) (No. 5) (No. 6)	1 1 1 1 1 1	----	1757 559 1757 559 1954 782 ---- ---- ----	---- ---- ---- 1905 449 1759 686 1905 449	2080 398 2080 399 2080 400	
23-86-36	CAP, Roof Inside Finish Moulding C1-L, C3-H (chrome)	12	----	----	1759 636		

★ Indicates use as required.

☐ Indicates parts not listed in any previous parts book.

March 8, 1963 Supersedes May 1, 1962.

Prices and specifications subject to change without notice.

Right and left part numbers are on same line,
first number is right, second number is left.

* Indicates change or addition.

CODE	REMARKS	PER CAR	SED.	SP. 4D.	SUB.	SP. CL. CP.	CV. CP.	
23-91-6	PANEL, Cowl Trim							
	C1, C2, C3 (paint as req'd)							
	(steel) (primed) Rt.	1	*2086 612	*2086 612	----	*2086 612	*2086 612	
	Lt.	1	2086 613	2086 613	----	2086 613	2086 613	
	(code 463)	1	----	----	----	2178 354-5	2178 354-5	
	Y1 (paint as req'd)	1	----	2241 520-1	----	2241 520-1	2241 520-1	
23-92-5	PANEL, Door Trim							
	C1-L (codes 301, 341, 401)	Frnt.	1	*2177 022-3	*2177 042-3	----	*2177 062-3	*2177 062-3
		Rr.	1	2177 024-5	2177 044-5	----	*2179 592-3	
	(code 302)	Frnt.	1	2179 576-7	2179 584-5			
		Rr.	1	2179 578-9	2179 586-7			
	(codes 303, 343, 403)	Frnt.	1	*2177 027-8	*2177 047-8	*2177 047-8	*2177 067-8	
		Rr.	1	2177 029-30	2177 049-50	2177 049-50		
	(codes 304, 344, 444)	Frnt.	1	*2177 032-3	*2177 052-3	*2177 557-8	*2177 072-3	*2177 565-6
		Rr.	1	2177 034-5	2177 054-5	2177 559-60		
	(code 404)	Frnt.	1	----	2177 557-8	2177 557-8	2177 565-6	2177 565-6
		Rr.	1	----	2177 559-60	2177 559-60		
	(codes 305, 345, 405, 425)	Frnt.	1	*2177 037-8	*2177 057-8	*2177 057-8	*2177 077-8	*2177 077-8
		Rr.	1	2177 039-40	2177 059-60	2177 059-60		
	(code 308)	Frnt.	1	2179 580-1	2179 588-9	----	2179 596-7	
		Rr.	1	2179 582-3	2179 590-1	----	----	----
	C2-M (codes 313, 413, 453, 463)	Frnt.	1	----	2177 573-4	----	2177 593-4	2177 593-4
		Rr.	1	----	2177 575-6			
	(codes 314, 414, 454)	Frnt.	1	----	2177 588-9	----	2177 608-9	
	Rr.	1	----	2177 590-1				
(codes 315, 415, 455)	Frnt.	1	----	2177 583-4	----	2177 603-4		
	Rr.	1	----	2177 585-6				
(code 454)		1	----	----	----	2177 608-9	2177 608-9	
(code 455)		1	----	----	----	2177 603-4	2177 603-4	
(code 423)(police ambulance)	Frnt.	1	----	----	2177 047-8			
	Rr.	1	----	----	2177 049-50			
C3-H (code 331)	Frnt.	1	2178 078-9	2178 093-4				
	Rr.	1	2178 080-1	2178 095-6				
(code 333)	Frnt.	1	2178 083-4	2178 098-9				
	Rr.	1	2178 085-6					
	Rr. Rt.	1	----	2178 100				
	Rr. Lt.	1	----	2178 101				
(code 334)	Frnt.	1	2178 088-9	2178 103-4				
	Rr.	1	2178 090-1	2178 105-6				
(code 335)	Frnt.	1	2178 607-8	2178 108-9				
	Rr.	1	2178 609-10	2178 110-11				
(code 423)	Frnt.	1	----	----	2178 642-3			
	Rr.	1	----	----	2178 644-5			
(codes 424, 464)	Frnt.	1	----	2178 818-9	2178 818-9			
	Rr.	1	----	2178 820-1	2178 820-1			
(codes 425, 465)	Frnt.	1	----	2178 813-4	2178 813-4			
	Rr.	1	----	2178 815-6	2178 815-6			
(also specify 4 of 6023 476 screw)								
Y1-L (code 501)	Frnt.	1	----	2177 082-3	----	2177 110-1		
	Rr.	1	----	2177 084-5				
(code 502)	Frnt.	1	----	2177 089-90	----	2177 115-6		
	Rr.	1	----	2177 091-2				
(code 503)	Frnt.	1	----	2177 096-7	----	2177 120-1		
	Rr.	1	----	2177 098-9				
(code 504)	Frnt.	1	----	2177 103-4	----	2177 125-6		
	Rr.	1	----	2177 105-6				

★ Indicates use as required.

Printed in U.S.A.

⊞ Indicates parts not listed in any previous parts book.
Right and left part numbers are on same line,
first number is right, second number is left.

Prices and specifications subject to change without notice.
March 8, 1963 Supersedes May 1, 1962.

* Indicates change or addition.

1962 PASSENGER CAR PARTS CATALOG

INTERIOR TRIM

CODE	REMARKS	PER CAR	SED.	SP. 4D.	SUB.	SP. CL. CP.	CV. CP.
23-92-5	PANEL, Door Trim - Cont'd						
	Y1-M (code 511)	Frnt. 1	----	2177 220-1	----	2177 130-1	
		Rr. 1	----	2177 222-3			
	(code 512)	Frnt. 1	----	2177 227-8	----	2177 135-6	
		Rr. 1	----	2177 229-30			
	(code 513)	Frnt. 1	----	2177 234-5	----	2177 140-1	
		Rr. 1	----	2177 236-7			
	(code 514)	Frnt. 1	----	2177 241-2	----	2177 145-6	
		Rr. 1	----	2177 243-4			
	(code 515)	Frnt. 1	----	2177 248-9	----	2177 150-1	
		Rr. 1	----	2177 250-1			
	(code 516)	Frnt. 1	----	2177 253-4	----	2177 155-6	
		Rr. 1	----	2177 255-6			
	Y1-M (code 553)	Frnt. 1	----	2177 192-3	----	2177 160-1	2177 160-1
		Rr. 1	----	2177 194-5			
	(code 555)	Frnt. Rt. 1	----	2177 199	----	2177 165-6	2177 165-6
		Lt. 1	----	2177 200			
	(code 556)	Rr. 1	----	2177 201-2			
	Frnt. 1	----	2177 206-7	----	2177 168-9	2177 168-9	
	Rr. 1	----	2177 208-9				
(code 557)	Frnt. 1	----	2177 213-4	----	2177 171-2	2177 171-2	
	Rr. 1	----	2177 215-6				
(code 565)	Frnt. 1	----	2178 187-8				
	Rr. 1	----	2177 201-2				
(code 567)	Frnt. 1	----	2178 190-1				
	Rr. 1	----	2177 215-6				
Y1-H (code 521)	Frnt. 1	----	2177 258-9				
	Rr. 1	----	2177 260-1				
(code 522)	Frnt. 1	----	2177 272-3				
	Rr. 1	----	2177 274-5				
(code 523)	Frnt. 1	----	2177 279-80				
	Rr. 1	----	2177 281-2				
(codes 524, 534)	Frnt. 1	----	2177 265-6				
	Rr. 1	----	2177 267-8				
23-92-7	SCREW, Door Trim Panel Attaching C1, C2, C3	4	6000 621	6000 621	6000 621	6000 621	6000 621
23-92-8	FASTENER, Door Trim Panel C1, C2, C3, Y1	★	* 975 633	* 975 633	* 975 633		
23-92-25	RETAINER, Rear Door Trim Panel at Belt Y1	4	----	2161 879			
23-96-3	PANEL, Luggage Compartment Front Lining C1, C2, C3	1	----	----	----	2176 502	2176 502
	(black)	1	2178 600	2178 600	----	2178 825	
	(front lining panel) (C300-H)	1	----	----	----	----	2178 399
	(rear compartment partition) (C300-H)	1	----	----	----	2132 612	2132 863
	(rear compartment partition cover)(C300-H)	1	----	----	----	2132 613	2132 864
	Y1-L, Y1-M (light gray)	1	----	2169 678	----	2169 678	2175 373
	(dark gray)	1	----	2178 193	----	2178 193	2178 194
23-96-4	MEDALLION, Rear Compartment Partition C2-M	1	----	----	----	1828 420	1828 420

★ Indicates use as required.

☐ Indicates parts not listed in any previous parts book.

March 8, 1963 Supersedes May 1, 1962.

Printed in U.S.A.

Prices and specifications subject to change without notice.

Right and left part numbers are on same line,

first number is right, second number is left.

* Indicates change or addition.

CODE	REMARKS	PER CAR	SED.	SP. 4 D.	SUB.	SP. CL. CP.	CV. CP.
23-96-7	BEZEL, Rear Compartment Partition Medallion C2-M (w/studs) (w/o studs)	1	----	----	----	2162 250	2162 250
		1	----	----	----	2419 083	2419 083
23-96-8	LINING, Luggage Compartment or Wheelhouse Side C1, C2, C3 (codes 401, 404, 405, 453, 454, 455, 463)(deck lid hinge cover) (w/reinf. and extension) (black) (black) (code 423) (w/ledge cover) (vinyl) (codes 424, 425) (w/ledge cover) (vinyl) (code 423)(carpet)(cordovan) (code 424)(carpet)(black) (code 425)(carpet)(black) (codes 403, 423) (upper) (plastic) (cocoa) (codes 404, 424) (upper) (plastic) (black) (codes 405, 425) (upper) (plastic) (red) (also specify 6000 903 fasteners) Y1 (w/extension) (light gray) (dark gray) Rt. Lt. (light gray) (dark gray)	1	----	----	----	----	2132 543-4
		1	2177 901-2	2177 901-2	----	2177 901-2	2177 907-8
		1	----	----	----	2132 566-7	
		1	----	----	----	2132 541-2	
		1	----	----	----	2178 653-4	
		1	----	----	----	2176 998-9	
		1	----	----	----	2177 000-1	
		1	----	----	----	2178 649-50	
		1	----	----	----	2169 553-4	
		1	----	----	----	2177 004-5	
1	----	----	----	----	2175 369-70		
1	----	----	----	----	2178 199		
1	----	----	----	----	2178 200		
1	----	2175 367-8	----	----	----	2178 201-2	
1	----	2178 197-8	----	----	----	2178 201-2	
23-96-9	CLIP, Luggage Compartment Side Lining Retaining C1, C2, C3	★	2165 272	2165 272	----	2165 272	
23-96-10	PANEL, Luggage Compartment Deck Opening Lower Y1 (two piece) (gray)	1	----	2178 207	----	2178 207	2178 207
23-96-22	RETAINER, Rear Compartment Medallion C2-M (C 300)	1	----	----	----	2162 258	2162 258
23-99-4	COVER, Center Pillar Trim C1-L, C2-M, C3-H (paint as req'd) (gray) Y1	1	----	2176 637-8	2176 637-8		
		1	----	*2179 910-1			
23-99-41	COVER, Pillar Trim Retainer (sold by the inch) Y1 (codes 501, 511, 521) (blue) (codes 502, 512, 522) (green) (cordovan) (codes 515, 555) (red) (code 553) (tan) (codes 504, 514, 516, 524, 534, 556, 557, 567) (black)	★	----	*2177 909			
		★	----	2177 910			
		★	----	2177 911			
		★	----	2177 912			
		★	----	2177 913			
		★	----	2176 392			
		★	----				

★ Indicates use as required.

☐ Indicates parts not listed in any previous parts book.

Right and left part numbers are on same line,
first number is right, second number is left.

* Indicates change or addition.

1962 PASSENGER CAR PARTS CATALOG

INTERIOR TRIM

CODE	REMARKS	PER CAR	SED.	SP. 4 D.	SUB.	SP. CL. CP.	CV. CP.	
23-101-3	PANEL, Rear Quarter Trim C1-L, C2-M, C3-H (codes 301, 341, 521) (codes 302, 308) (codes 303, 343, 523) (codes 304, 334, 344, 524) (codes 305, 315, 335, 345, 415, 465) (code 444) (codes 314, 414) (codes 313, 413, 453) (code 314) (codes 315, 415)	1 1 1 1 1 1 1 1 1 1	*2132 248-9 2144 275-6 *2132 250-1 *2132 252-3 *2132 254-5 2132 762-3 ----- ----- ----- -----	*2132 302-3 2132 466-7 *2132 304-5 *2132 306-7 *2132 308-9 2132 466-7 2132 334-5 ----- -----	----- ----- ----- ----- ----- ----- ----- ----- ----- -----	----- ----- ----- ----- ----- ----- ----- ----- ----- -----	----- ----- ----- ----- ----- ----- ----- ----- ----- -----	----- ----- ----- ----- ----- ----- ----- ----- ----- -----
	C1-L (codes 301, 341, 401) (codes 303, 343) (code 404) (codes 304, 344, 404) (codes 305, 345, 405) C2-M (code 454) (code 455) (code 463) (code 302) (code 308) (also specify 2 of 6000 621 screw) (sp. cl. cp. & conv. cp.)	1 1 1 1 1 1 1 1 1 1	----- ----- ----- ----- ----- ----- ----- ----- ----- -----	----- ----- ----- ----- ----- ----- ----- ----- ----- -----	----- ----- ----- ----- ----- ----- ----- ----- ----- -----	*2177 064-5 *2177 069-70 2178 382-3 *2177 074-5 *2177 079-80 2177 610-1 2177 605-6 2178 360-1 *2179 594-5 2179 598-9	*2177 562-3 ----- ----- *2177 567-8 *2177 570-1 2177 618-9 2177 621-2 2132 685-6	
	Y1-L (upper) (code 501) (code 502) (code 503) Rt. Lt. (code 504) Y1-M (upper) (code 511) (code 512) (code 513) (code 514) (code 515) (codes 516, 556)	1 1 1 1 1 1 1 1 1 1	----- ----- ----- ----- ----- ----- ----- ----- ----- -----	2177 086-7 2177 093-4 2177 100 2177 101 2177 107-8 2177 224-5 2177 231-2 2177 238-9 2177 245-6 2177 203-4 2177 210-1	----- ----- ----- ----- ----- ----- ----- ----- ----- -----	2177 112-3 2177 117-8 2177 122-3 ----- 2177 127-8 ----- ----- ----- ----- ----- -----	----- ----- ----- ----- ----- ----- ----- ----- ----- -----	
	Y1-L, Y1-M, Y1-H (lower) (codes 501, 511, 521) (codes 502, 512, 522) (codes 503, 513, 523) (codes 504, 514, 534)	1 1 1 1	----- ----- ----- -----	2177 939-40 2177 941-2 2177 943-4 2177 945-6	----- ----- ----- -----	----- ----- ----- -----	----- ----- ----- -----	
	Y1-M (code 511) (code 512) (code 513) (code 514) (codes 515, 555, 565) (codes 516, 556) (code 553)	1 1 1 1 1 1 1	----- ----- ----- ----- ----- ----- -----	----- ----- ----- ----- 2177 203-4 ----- 2177 196-7	----- ----- ----- ----- ----- ----- -----	2177 132-3 2177 137-8 2177 142-3 2177 147-8 2177 152-3 2177 157-8 2177 162-3	----- ----- ----- ----- 2177 181-2 ----- 2177 178-9	
	Y1-L, Y1-M, Y1-H (lower) (codes 557, 567) Y1-H (code 521) (code 522) (code 523) (codes 524, 534)	1 1 1 1 1	----- ----- ----- ----- -----	2177 217-8 2177 262-3 2177 276-7 2177 283-4 2177 269-70	----- ----- ----- ----- -----	----- ----- ----- ----- -----	----- ----- ----- ----- -----	
	Y1-M (lower) (code 553) (codes 515, 555) (codes 516, 556) (code 557)	1 1 1 1	----- ----- ----- -----	----- ----- ----- -----	----- ----- ----- -----	----- ----- ----- 2177 173-4	----- ----- ----- 2177 178-9 2177 181-2 2177 184-5	

★ Indicates use as required.

□ Indicates parts not listed in any previous parts book.
March 8, 1963 Supersedes May 1, 1962.

Prices and specifications subject to change without notice.
Right and left part numbers are on same line,
first number is right, second number is left.

* Indicates change or addition.

CODE	REMARKS	PER CAR	SED.	SP. 4 D.	SUB.	SP. CL. CP.	CV. CP.
23-103-10	ARM and BRACKET, Visor C1, C2, C3 (chrome) (for padded visor)	1	2292 108-9	2292 108-9	2292 108-9	2292 108-9	2161 588-9
		1	2082 676-7	-----	2082 676-7	2082 676-7	
	1	-----	2085 242-3	-----	2085 242-3		
	6	187 709	187 709	187 709	187 709		
23-103-34	SPRING, w/HOOK, Windshield Upper Garnish Moulding Visor C1, C2, C3 Y1 (attaching screw)	1	1964 262	1964 262	1964 262	1964 262	1964 332
		2	-----	1900 776	-----	1900 776	
		2	148 095	148 095	148 095	148 095	
23-103-37	SPACER, Visor Support Hook C1, C2, C3	2	2165 039	2165 039	2165 039	2165 039	
23-103-48	SUPPORT, Visor Inner C1, C2, C3 Y1	2	2193 096	2193 096	2193 096	2193 096	2193 096
		2	-----	2161 687	-----	2161 687	
23-108-4	CUSHION, Front Seat C1-L (manual) (code 301) (code 302) (w/airfoam) (6 way elec.) (6 way elec. w/airfoam) (code 308) (w/airfoam) (6 way elec.) (6 way elec. w/airfoam)	1	2131 493	2131 493	-----	2131 566	
		1	2132 871	2132 871	-----	2132 910	
		1	2132 892	2132 892	-----	2132 930	
		1	2132 885	2132 885	-----	2132 924	
		1	2132 896	2132 896	-----	2132 934	
		1	2132 872	2132 872	-----	2132 911	
		1	2132 893	2132 893	-----	2132 931	
		1	2132 886	2132 886	-----	2132 925	
		1	2132 897	2132 897	-----	2132 935	
		1	2131 494	2131 494	-----	2131 567	
		1	2131 495	2131 495	-----	2131 568	
		1	2131 496	2131 496	-----	2131 569	
		1	2131 533	2131 533	-----	2131 610	
		1	2131 534	2131 534	-----	2131 611	
1	2131 535	2131 535	-----	2131 612			
1	2131 536	2131 536	-----	2131 613			
C1-L (6 way elec.) (code 301) (code 303) (code 304) (code 305) C1-L (6 way elec. w/airfoam) (code 301) (code 303) (code 304) (code 305)	1	2131 529	2131 529	-----	2131 606		
	1	2131 530	2131 530	-----	2131 607		
	1	2131 531	2131 531	-----	2131 608		
	1	2131 532	2131 532	-----	2131 609		
	1	2131 537	2131 537	-----	2131 614		
	1	2131 538	2131 538	-----	2131 615		
	1	2131 539	2131 539	-----	2131 616		
	1	2131 540	2131 540	-----	2131 617		
C1-L (police car) (code 301) (code 303) (code 304) (code 305) (code 444)	1	2132 788					
	1	2132 789					
	1	2132 790					
	1	2132 791					
	1	2132 771					
C1-L (manual) (code 341) (code 343) (code 344) (code 345) C1-L (w/airfoam pad) (code 341) (code 343) (code 344) (code 345)	1	*2144 356	*2144 356	-----	*2144 332		
	1	*2144 357	*2144 357	-----	*2144 333		
	1	*2144 358	*2144 358	-----	*2144 334		
	1	-----	-----	-----	*2144 335		
	1	*2144 380	*2144 380	-----	*2144 408		
	1	*2144 381	*2144 381	-----	*2144 409		
	1	*2144 382	*2144 382	-----	*2144 410		
	1	*2144 383	*2144 383	-----	*2144 411		

★ Indicates use as required.

E Indicates parts not listed in any previous parts book.

March 8, 1963 Supersedes May 1, 1962.

Prices and specifications subject to change without notice.

Right and left part numbers are on same line,
first number is right, second number is left.

* Indicates change or addition.

CODE	REMARKS	PER CAR	SED.	SP. 4D.	SUB.	SP. CL. CP.	CV. CP.
23-108-4	CUSHION, Front Seat - Cont'd						
	C1-L (6 way elec.)						
	(code 341)	1	*2144 368	*2144 368	----	*2144 396	
	(code 343)	1	*2144 369	*2144 369	----	*2144 397	
	(code 344)	1	*2144 370	*2144 370	----	*2144 398	
	(code 345)	1	*2144 371	*2144 371	----	*2144 399	
	C1-L (6 way elec. w/airfoam pad)						
	(code 341)	1	*2144 388	*2144 388	----	*2144 416	
	(code 343)	1	*2144 389	*2144 389	----	*2144 417	
	(code 344)	1	*2144 390	*2144 390	----	*2144 418	
	(code 345)	1	*2144 391	*2144 391	----	*2144 419	
	C2-M (manual) (code 313)	1	----	2131 733	----	2131 810	
	(code 314)	1	----	2131 734	----	2131 811	
	(code 315)	1	----	2131 735	----	2131 812	
	C2-M (6 way elec.) (code 313)	1	----	2131 754	----	2131 831	
	(code 314)	1	----	2131 755	----	2131 832	
	(code 315)	1	----	2131 756	----	2131 833	
	C3-H (manual) (code 331)	1	2132 274	2132 274			
	(code 333)	1	2132 275	2132 275			
	(code 334)	1	2132 276	2132 276			
	(code 335)	1	2132 277	2132 277			
	C3-H (6 way elec.) (code 331)	1	2132 325	2132 325			
	(code 333)	1	2132 326	2132 326			
	(code 334)	1	2132 327	2132 327			
	(code 335)	1	2132 328	2132 328			
	C1-L, C2-M, C3-H (manual)						
	(codes 403, 423)	1	----	----	2132 590		
	(code 413)	1	----	2131 877			
	(codes 404, 414, 424)	1	----	2131 878	2131 878	2131 929	2131 929
	(codes 405, 415, 425, 465)	1	----	2131 879	2131 879	2131 930	2131 930
	(code 453)	2	----	----	----	2132 714	2132 714
	(code 454)	2	----	----	----	2132 716	2132 716
	(code 455)	2	----	2132 718	----	2132 718	2132 718
	C1-L, C2-M, C3-H (6 way elec.)						
	(codes 403, 423)	1	----	----	2132 601		
	(code 413)	1	----	2131 898			
	(codes 404, 414, 424, 464)	1	----	2131 899	2131 899	2131 950	2131 950
	(codes 405, 415, 425, 465)	1	----	2131 900	2131 900	2131 951	2131 951
	(code 463)	1	----	----	----	2132 654-5	2132 654-5
	C2-M (code 453)	1	----	----	----	2132 424-5	2132 424-5
	Center	1	----	----	----	2132 436	2132 436
	(code 454)	1	----	----	----	2132 426-7	2132 426-7
	Center	1	----	----	----	2132 437	2132 437
	(code 455) Rt.	1	----	----	----	*2132 428	*2132 428
	Lt.	1	----	----	----	*2132 718	*2132 718
	Center	1	----	----	----	2132 438	2132 438
	C1-L (manual) (code 401)	1	----	----	----	----	2131 928
	(code 404)	1	----	----	----	----	2131 929
	(code 405)	1	----	----	----	----	2131 930
	C1-L (6 way elec.) (code 401)	1	----	----	----	----	2131 949
	(code 404)	1	----	----	----	----	2131 950
	(code 405)	1	----	----	----	----	2131 951
	C3-H (parts used in C1-L ambulance)						
	(codes 403, 423)	1	----	----	2132 809		
	(codes 404, 424)	1	----	----	2132 810		
	(codes 405, 425)	1	----	----	2132 811		

★ Indicates use as required.
 ☐ Indicates parts not listed in any previous parts book.
 Right and left part numbers are on same line,
 first number is right, second number is left.
 * Indicates change or addition.

1962 PASSENGER CAR PARTS CATALOG

INTERIOR TRIM

CODE	REMARKS	PER CAR	SED.	SP. 4 D.	SUB.	SP. CL. CP.	CV. CP.
23-108-4	CUSHION, Front Seat - Cont'd						
	Y1-L (code 501)	1	----	*2148 670	----	*2148 750	
	(code 502)	1	----	2148 671	----	2148 751	
	(code 503)	1	----	2148 672	----	2148 752	
	(code 504)	1	----	2148 673	----	2148 753	
	Y1-L (6 way elec.) (code 501)	1	----	2148 674	----	2148 754	
	(code 502)	1	----	2148 675	----	2148 755	
	(code 503)	1	----	2148 676	----	2148 756	
	(code 504)	1	----	2148 677	----	2148 757	
	Y1-M (code 511)	1	----	*2149 122	----	*2148 814	
	(code 512)	1	----	2149 123	----	2148 815	
	(code 513)	1	----	2149 124	----	2148 816	
	(code 514)	1	----	2149 125	----	2148 817	
	(code 515)	1	----	2149 126	----	2148 818	
	(code 516)	1	----	2149 127	----	2148 819	
	Y1-H (code 521)	1	----	*2149 900			
	(code 522)	1	----	2149 318			
	(code 523)	1	----	2149 319			
	(code 524)	1	----	2149 320			
	(code 534)	1	----	2149 317			
	Y1-M (code 553)	1	----	*2149 128	----	*2148 824	*2148 824
	(codes 555, 565)	1	----	2149 129	----	2148 825	2148 825
	(code 556)	1	----	2149 130	----	2148 826	2148 826
	(codes 557, 567)	1	----	2149 131	----	2148 827	2148 827
23-108-5	COVER, Front Seat Cushion						
	C1-L (code 301)	1	2131 497	2131 497	----	2131 570	
	(code 302)	1	2132 873	2132 873	----	2132 912	
	(code 303)	1	2131 498	2131 498	----	2131 571	
	(code 304)	1	2131 499	2131 499	----	2131 572	
	(code 305)	1	2131 500	2131 500	----	2131 573	
	(code 308)	1	2132 874	2132 874	----	2132 913	
	C1-L (code 341)	1	*2144 292	*2144 292	----	*2144 336	
	(code 343)	1	*2144 293	*2144 293	----	*2144 337	
	(code 344)	1	*2144 294	*2144 294	----	*2144 338	
	(code 345)	1	*2144 295	*2144 295	----	*2144 339	
	C3-H (code 331)	1	2132 278	2132 278			
	(code 333)	1	2132 279	2132 279			
	(code 334)	1	2132 280	2132 280			
	(code 335)	1	2132 281	2132 281			
	C2-M (code 313)	1	----	2131 736	----	2131 813	
	(code 314)	1	----	2131 737	----	2131 814	
	(code 315)	1	----	2131 738	----	2131 815	
	C1-L, C2-M, C3-H	1	----	----	2132 591		
	(codes 403, 423)	1	----	----			
	(code 413)	1	----	2131 880			
	(codes 404, 414, 424, 464)	1	----	2131 881	2131 881		
	(codes 405, 415, 425, 465)	1	----	2131 882	2131 882		
	(code 463)	1	----	----	----	2132 674	2132 674
	C2-M (code 453)	2	----	----	----	2132 727	2132 727
	(code 454) Center	1	----	----	----	2132 439	2132 439
	(code 454)	2	----	----	----	*2132 729	*2132 729
	(code 455) Center	1	----	----	----	2132 440	2132 440
	(code 455)	2	----	----	----	2132 731	2132 731
	(code 455) Center	1	----	----	----	2132 441	2132 441
	C1-L (code 401)	1	----	----	----	----	2131 931
	(code 404)	1	----	----	----	----	2131 932
	(code 405)	1	----	----	----	----	2131 933
	C1-L (police)	1	2132 772	----	----	----	
	(code 444)	1					

★ Indicates use as required.

☐ Indicates parts not listed in any previous parts book.

March 8, 1963 Supersedes May 1, 1962.

Printed in U.S.A.

Prices and specifications subject to change without notice.

Right and left part numbers are on same line,
first number is right, second number is left.

* Indicates change or addition.

CODE	REMARKS	PER CAR	SED.	SP. 4 D.	SUB.	SP. CL. CP.	CV. CP.
23-108-5	COVER, Front Seat Cushion-Cont'd						
	Y1-L (code 501)	1	----	2148 666	----	2148 746	
	(code 502)	1	----	2148 667	----	2148 747	
	(code 503)	1	----	2148 668	----	2148 748	
	(code 504)	1	----	2148 669	----	2148 749	
	Y1-M (code 511)	1	----	2149 112	----	2148 808	
	(code 512)	1	----	2149 113	----	2148 809	
	(code 513)	1	----	2149 114	----	2148 810	
	(code 514)	1	----	2149 115	----	2148 811	
	(code 515)	1	----	2149 116	----	2148 812	
	(code 516)	1	----	2149 117	----	2148 813	
	(code 553)	1	----	2149 118	----	2148 820	2148 820
	(codes 555, 565)	1	----	2149 119	----	2148 821	2148 821
	(code 556)	1	----	2149 120	----	2148 822	2148 822
	(codes 557, 567)	1	----	2149 121	----	2148 823	2148 823
	Y1-H (code 521)	1	----	2149 904			
	(code 522)	1	----	2149 313			
	(code 523)	1	----	2149 314			
	(code 524)	1	----	2149 315			
	(code 534)	1	----	2149 312			
23-108-12	BACK, Front Seat (less cushion)						
	C1-L						
	(code 302)	1	2132 867	2132 867	----	2132 902-3	
	(code 308)	1	2132 868	2132 868	----	2132 904-5	
	C1-L (w/seat back insert)						
	(code 301)	1	*2131 485	*2131 485	----	*2131 550-1	
	(code 303)	1	*2131 486	*2131 486	----	*2131 552-3	
	(code 304)	1	*2131 487	*2131 487	----	*2131 554-5	
	(code 305)	1	*2131 488	*2131 488	----	*2131 556-7	
	C1-L (less seat back insert)						
	(code 301)	1	*2144 424	*2144 424	----	*2144 456-7	
	(code 303)	1	*2144 425	*2144 425	----	*2144 458-9	
	(code 304)	1	*2144 426	*2144 426	----	*2144 460-1	
	(code 305)	1	*2144 427	*2144 427	----	*2144 462-3	
	C1-L (w/seat back insert)						
	(code 341)	1	*2144 281	*2144 281	----	*2144 316-7	
	(code 343)	1	*2144 282	*2144 282	----	*2144 318-9	
	(code 344)	1	*2144 283	*2144 283	----	*2144 320-1	
	(code 345)	1	*2144 284	*2144 284	----	*2144 322-3	
	C1-L (less seat back insert)						
	(code 341)	1	*2144 504	*2144 504	----	*2144 536-7	
	(code 343)	1	*2144 505	*2144 505	----	*2144 538-9	
	(code 344)	1	*2144 506	*2144 506	----	*2144 540-1	
	(code 345)	1	*2144 507	*2144 507	----	*2144 542-3	
	C1-L (police)(w/seat back insert)						
	(code 301)	1	*2132 781				
	(code 303)	1	*2132 782				
	(code 304)	1	*2132 783				
	(code 305)	1	*2132 784				
	C1-L (police)(less seat back insert)						
	(code 301)	1	*2144 448				
	(code 303)	1	*2144 449				
	(code 304)	1	*2144 450				
	(code 305)	1	*2144 451				
	(code 444)	1	*2132 769				
23-108-13	FRAME, Front Seat Back (trimmed)						
	Y1-L (code 501)	1	----	2148 682			
	(code 502)	1	----	2148 683			
	(code 503)	1	----	2148 684			
	(code 504)	1	----	2148 685			

★ Indicates use as required.
 □ Indicates parts not listed in any previous parts book.
 Right and left part numbers are on same line,
 first number is right, second number is left.
 * Indicates change or addition.

1962 PASSENGER CAR PARTS CATALOG

INTERIOR TRIM

CODE	REMARKS	PER CAR	SED.	SP. 4 D.	SUB.	SP. CL. CP.	CV. CP.
23-108-13	FRAME, Front Seat Back (trimmed) - Cont'd						
	Y1-L (code 501) Rt.	1	----	----	----	2148 766	
	Lt.	1	----	----	----	2148 770	
	(code 502) Rt.	1	----	----	----	2148 767	
	Lt.	1	----	----	----	2148 771	
	(code 503) Rt.	1	----	----	----	2148 768	
	Lt.	1	----	----	----	2148 772	
	(code 504) Rt.	1	----	----	----	2148 769	
	Lt.	1	----	----	----	2148 773	
	Y1-M (code 511)	1	----	2149 170			
	(code 512)	1	----	2149 171			
	(code 513)	1	----	2149 172			
	(code 514)	1	----	2149 173			
	(code 515)	1	----	2149 174			
	(code 516)	1	----	2149 175			
	Y1-M (code 511) Rt.	1	----	----	----	2148 848	
	Lt.	1	----	----	----	2148 854	
	(code 512) Rt.	1	----	----	----	2148 849	
	Lt.	1	----	----	----	2148 855	
	(code 513) Rt.	1	----	----	----	2148 850	
	Lt.	1	----	----	----	2148 856	
	(code 514) Rt.	1	----	----	----	2148 851	
	Lt.	1	----	----	----	2148 857	
	(code 515) Rt.	1	----	----	----	2148 852	
	Lt.	1	----	----	----	2148 858	
	(code 516) Rt.	1	----	----	----	2148 853	
	Lt.	1	----	----	----	2148 859	
	(code 553)	1	----	2149 176			
	(codes 555, 565)	1	----	2149 177			
	(codes 557, 567)	1	----	2149 179			
	Y1-H (code 521)	1	----	2149 337			
	(code 522)	1	----	2149 338			
	(code 523)	1	----	2149 339			
	(codes 524, 534)	1	----	2149 340			
	Y1-M (code 553) Rt.	1	----	----	----	2148 860	
	Lt.	1	----	----	----	2148 864	
	(code 555) Rt.	1	----	----	----	2148 861	
	Lt.	1	----	----	----	2148 865	
	(code 556) Rt.	1	----	----	----	2148 862	
	Lt.	1	----	----	----	2148 866	
	(code 557) Rt.	1	----	----	----	2148 863	
	Lt.	1	----	----	----	2148 867	
23-108-15	SPRING and COVER, Front Seat Back						
	C3-H (code 331)	1	2132 264	2132 264			
	(code 333)	1	2132 265	2132 265			
	(code 334)	1	2132 266	2132 266			
	(code 335)	1	2132 267	2132 267			
	C2-M (code 313)	1	----	2131 724			
	(code 314)	1	----	2131 725			
	(code 315)	1	----	2131 726			
	C1-L, C2-M, C3-H, (code 413)	1	----	2131 868			
	(codes 404, 414, 424)	1	----	2131 869	2131 869	2131 912-3	2131 912-3
	(codes 405, 415, 425, 465)	1	----	2131 870	2131 870	2131 914-5	2131 914-5
	(codes 403, 423)	1	----	----	2132 587		
	(code 463)	2	----	----	----	2132 639	2132 639
	C2-M (code 313) Rt.	1	----	----	----	2131 792	
	Lt.	1	----	----	----	2131 793	
	(code 314) Rt.	1	----	----	----	2131 794	
	Lt.	1	----	----	----	2131 795	

★ Indicates use as required.

Page IT-172

Printed in U.S.A.

☐ Indicates parts not listed in any previous parts book.
 March 8, 1963 Supersedes May 1, 1962.

Prices and specifications subject to change without notice.
 Right and left part numbers are on same line,
 first number is right, second number is left.

* Indicates change or addition.

CODE	REMARKS	PER CAR	SED.	SP. 4 D.	SUB.	SP. CL. CP.	CV. CP.
23-108-15	SPRING and COVER, Front Seat Back - Cont'd						
C2-M (code 315)	Rt.	1	----	----	----	2131 796	
	Lt.	1	----	----	----	2131 797	
(code 453)		2	----	----	----	2132 409	2132 409
(code 454)		2	----	----	----	2132 410	2132 410
(code 455)		2	----	----	----	2132 411	2132 411
C1-L (code 401)	Rt.	1	----	----	----	----	2131 910
	Lt.	1	----	----	----	----	2131 911
(code 404)	Rt.	1	----	----	----	----	2131 912
	Lt.	1	----	----	----	----	2131 913
(code 405)	Rt.	1	----	----	----	----	2131 914
	Lt.	1	----	----	----	----	2131 915
Y1-L (code 501)		1	----	2148 690			
(code 502)		1	----	2148 691			
(code 503)		1	----	2148 692			
(code 504)		1	----	2148 693			
Y1-L (code 501)	Rt.	1	----	----	----	2148 782	
	Lt.	1	----	----	----	2148 786	
(code 502)	Rt.	1	----	----	----	2148 783	
	Lt.	1	----	----	----	2148 787	
(code 503)	Rt.	1	----	----	----	2148 784	
	Lt.	1	----	----	----	2148 788	
(code 504)	Rt.	1	----	----	----	2148 785	
	Lt.	1	----	----	----	2148 789	
Y1-M (code 511)		1	----	2149 190			
(code 512)		1	----	2149 191			
(code 513)		1	----	2149 192			
(code 514)		1	----	2149 193			
(code 515)		1	----	2149 194			
(code 516)		1	----	2149 195			
(code 553)		1	----	2149 196			
(codes 555, 565)		1	----	2149 197			
(code 556)		1	----	2149 198			
(codes 557, 567)		1	----	2149 199			
Y1-M (code 553)	Rt.	1	----	----	----	2148 900	
	Lt.	1	----	----	----	2148 904	
(code 555)	Rt.	1	----	----	----	2148 901	
	Lt.	1	----	----	----	2148 905	
(code 556)	Rt.	1	----	----	----	2148 902	
	Lt.	1	----	----	----	2148 906	
(code 557)	Rt.	1	----	----	----	2148 903	
	Lt.	1	----	----	----	2148 907	
Y1-H (code 521)		1	----	2149 897			
(code 522)		1	----	2149 348			
(code 523)		1	----	2149 349			
(code 524)		1	----	2149 350			
(code 534)		1	----	2149 347			
23-108-16	COVER, Front Seat Back						
C1-L (code 302)		1	2132 869	2132 869	----	2132 906-7	
(code 308)		1	2132 870	2132 870	----	2132 908-9	
C1-L (w/seat back insert)		1	*2131 489	*2131 489	----	*2131 558-9	
(code 301)		1	*2131 490	*2131 490	----	*2131 560-1	
(code 303)		1	*2131 491	*2131 491	----	*2131 562-3	
(code 304)		1	*2131 492	*2131 492	----	*2131 564-5	
(code 305)		1			----		

★ Indicates use as required.
 ☐ Indicates parts not listed in any previous parts book.
 Right and left part numbers are on same line,
 first number is right, second number is left.
 * Indicates change or addition.

1962 PASSENGER CAR PARTS CATALOG

INTERIOR TRIM

CODE	REMARKS	PER CAR	SED.	SP. 4 D.	SUB.	SP. CL. CP.	CV. CP.
23-108-16	COVER, Front Seat Back - Cont'd						
	C1-L (less seat back insert)						
	(code 301)	1	*2144 428	*2144 428	----	*2144 464-5	
	(code 303)	1	*2144 429	*2144 429	----	*2144 466-7	
	(code 304)	1	*2144 430	*2144 430	----	*2144 468-9	
	(code 305)	1	*2144 431	*2144 431	----	*2144 470-1	
	C2-M (code 313)	1	----	2131 727	----	2131 798-9	
	(code 314)	1	----	2131 728	----	2131 800-1	
	(code 315)	1	----	2131 729	----	2131 802-3	
	C1-L (code 401)	1	----	----	----	----	2131 916-7
	(code 404)	1	----	----	----	2131 918-9	2131 918-9
	(code 405)	1	----	----	----	2131 920-1	2131 920-1
	(code 331)	1	2132 268	2132 268	----		
	(code 333)	1	2132 269	2132 269	----		
	(code 334)	1	2132 270	2132 270	----		
	(code 335)	1	2132 271	2132 271	----		
	C1-L (w/seat back insert)						
	(code 341)	1	*2144 285	*2144 285	----	*2144 324-5	
	(code 343)	1	*2144 286	*2144 286	----	*2144 326-7	
	(code 344)	1	*2144 287	*2144 287	----	*2144 328-9	
	(code 345)	1	*2144 288	*2144 288	----	*2144 330-1	
	C1-L (less seat back insert)						
	(code 341)	1	*2144 508	*2144 508	----	*2144 544-5	
	(code 343)	1	*2144 509	*2144 509	----	*2144 546-7	
	(code 344)	1	*2144 510	*2144 510	----	*2144 548-9	
	(code 345)	1	*2144 511	*2144 511	----	*2144 550-1	
	C1, C2, C3, (code 413)	1	----	2131 871			
	(codes 404, 414, 424, 464)	1	----	*2131 872	*2131 872		
	(codes 405, 415, 425, 465)	1	----	2131 873	2131 873		
	(codes 403, 423)	1	----	----	2132 588		
	C2-M (code 453)	2	----	*2132 412	----	2132 412	2132 412
	(code 454)	2	----	*2132 413	----	2132 413	2132 413
	(code 455)	2	----	*2132 414	----	2132 414	2132 414
	(code 463)	2	----	----	----	2132 650	2132 650
	Y1-L (code 501)	1	----	2148 686			
	(code 502)	1	----	2148 687			
	(code 503)	1	----	2148 688			
	(code 504)	1	----	2148 689			
	Y1-L (code 501)	Rt.	1	----	----	2148 774	
		Lt.	1	----	----	2148 778	
	(code 502)	Rt.	1	----	----	2148 775	
		Lt.	1	----	----	2148 779	
	(code 503)	Rt.	1	----	----	2148 776	
		Lt.	1	----	----	2148 780	
	(code 504)	Rt.	1	----	----	2148 777	
		Lt.	1	----	----	2148 781	
	Y1-M (code 511)		1	----	2149 180		
	(code 512)		1	----	2149 181		
	(code 513)		1	----	2149 182		
	(code 514)		1	----	2149 183		
	(code 515)		1	----	2149 184		
	(code 516)		1	----	2149 185		
	Y1-M (code 511)	Rt.	1	----	----	2148 868	
		Lt.	1	----	----	2148 874	
	(code 512)	Rt.	1	----	----	2148 869	
		Lt.	1	----	----	2148 875	
	(code 513)	Rt.	1	----	----	2148 870	
		Lt.	1	----	----	2148 876	
	(code 514)	Rt.	1	----	----	2148 871	
		Lt.	1	----	----	2148 877	

★ Indicates use as required.

☐ Indicates parts not listed in any previous parts book.

March 8, 1963 Supersedes May 1, 1962.

Prices and specifications subject to change without notice.

Right and left part numbers are on same line,

first number is right, second number is left.

* Indicates change or addition.

CODE	REMARKS	PER CAR	SED.	SP. 4 D.	SUB.	SP. CL. CP.	CV. CP.
23-108-32	COVER, Front Seat Back - Cont'd						
	Y1-M (code 515) Rt.	1	----	----	----	2148 872	
	Lt.	1	----	----	----	2148 878	
	(code 516) Rt.	1	----	----	----	2148 873	
	Lt.	1	----	----	----	2148 879	
	Y1-M (code 553)	1	----	2149 186			
	(codes 555, 565)	1	----	2149 187			
	(code 556)	1	----	2149 188			
	(codes 557, 567)	1	----	2149 189			
	Y1-H (code 521)	1	----	2149 901			
	(code 522)	1	----	2149 343			
	(code 523)	1	----	2149 344			
	(code 524)	1	----	2149 345			
	(code 534)	1	----	2149 342			
	Y1-M (code 553) Rt.	1	----	----	----	2148 880	2148 880
	Lt.	1	----	----	----	2148 884	2148 884
	(code 555) Rt.	1	----	----	----	2148 881	2148 881
	Lt.	1	----	----	----	2148 885	2148 885
	(code 556) Rt.	1	----	----	----	2148 882	2148 882
	Lt.	1	----	----	----	2148 886	2148 886
	(code 557) Rt.	1	----	----	----	2148 883	2148 883
	Lt.	1	----	----	----	2148 887	2148 887
23-108-32	PANEL, Back of Front Seat Back						
	C3-H (code 331)	1	2177 507	2177 507			
	(code 333)	1	2177 508	2177 508			
	(code 334)	1	2177 509	2177 509			
	(code 335)	1	2177 510	2177 510			
	C1-L, C2-M, C3-H (codes 313, 413)	1	----	2177 493			
	(code 314)	1	----	2177 496			
	(codes 404, 414, 424)	1	----	2177 496	2177 496		
	(codes 315, 405, 415, 425, 465)	1	----	2177 495	2177 495		
	(codes 403, 423)(panel)	1	----	----	2178 620		
	(codes 403, 423)(cover)	1	----	----	2178 620		
	C2-M (code 313)	1	----	----	----	2177 503-4	
	(code 314) Rt.	1	----	----	----	2177 499	
	Lt.	1	----	----	----	2177 500	
	(code 315)	1	----	----	----	2177 501-2	
	(code 453)	2	----	----	----	*2132 415	
	(code 454)	2	----	----	----	*2132 416	
	(code 455)	2	----	----	----	*2132 417	
	C1-L (panel) (code 401)	1	----	----	----	----	2177 497-8
	(code 404) Rt.	1	----	----	----	----	2177 499
	Lt.	1	----	----	----	----	2177 500
	(code 405)	1	----	----	----	----	2177 501-2
	C3-H (cover)(codes 321, 331)	1	2177 507	2177 507			
	(codes 323, 333)	1	2177 508	2177 508			
	(codes 324, 334)	1	2177 509	2177 509			
	(codes 335)	1	2177 510	2177 510			
	C1-L, C2-M, C3-H, (cover) (codes 313, 413)	1	----	2177 493	----	2177 503-4	
	(code 314)	1	----	2177 496	----	2177 498-9	
	(codes 404, 414, 424)	1	----	2177 496	2177 496		
	(codes 315, 405, 415, 425, 465)	1	----	2177 495	2177 495		
	C2-M (cover) (code 453)	1	----	*2132 418	----	2132 418	2132 418
	(code 454)	1	----	*2132 419	----	2132 419	2132 419
	(code 455)	1	----	*2132 420	----	2132 420	2132 420

★ Indicates use as required.

☐ Indicates parts not listed in any previous parts book.

Right and left part numbers are on same line, first number is right, second number is left.

* Indicates change or addition.

1962 PASSENGER CAR PARTS CATALOG

INTERIOR TRIM

CODE	REMARKS	PER CAR	SED.	SP. 4 D.	SUB.	SP. CL. CP.	CV. CP.
23-108-32	PANEL, Back of Front Seat Back - Cont'd						
	C2-M (code 463) (panel)	2	----	----	----	2132 651	2132 651
	(cover)	2	----	----	----	2132 652	2132 652
	C1-L (cover)(code 401)	1	----	----	----	2177 497-8	2177 497-8
	(code 404) Rt.	1	----	----	----	2177 499	2177 499
	Lt.	1	----	----	----	2177 500	2177 500
	(code 405)	1	----	----	----	2177 501-2	2177 679-80
	Y1-L (panel) (code 501)	1	----	2148 678			
	(code 502)	1	----	2148 679			
	(code 503)	1	----	2148 680			
	(code 504)	1	----	2148 681			
	Y1-L (panel) (code 501) Rt.	1	----	----	----	2148 758	
	Lt.	1	----	----	----	2148 762	
	(code 502) Rt.	1	----	----	----	2148 759	
	Lt.	1	----	----	----	2148 763	
	(code 503) Rt.	1	----	----	----	2148 760	
	Lt.	1	----	----	----	2148 764	
	(code 504) Rt.	1	----	----	----	2148 761	
	Lt.	1	----	----	----	2148 765	
	Y1-M (panel) (code 511)	1	----	2149 160			
	(code 512)	1	----	2149 161			
	(code 513)	1	----	2149 162			
	(code 514)	1	----	2149 163			
	(code 515)	1	----	2149 164			
	(code 516)	1	----	2149 165			
	Y1-M (panel) (code 511) Rt.	1	----	----	----	2148 828	
	Lt.	1	----	----	----	2148 834	
	(code 512) Rt.	1	----	----	----	2148 829	
	Lt.	1	----	----	----	2148 835	
	(code 513) Rt.	1	----	----	----	2148 830	
	Lt.	1	----	----	----	2148 836	
	(code 514) Rt.	1	----	----	----	2148 831	
	Lt.	1	----	----	----	2148 837	
	(code 515) Rt.	1	----	----	----	2148 832	
	Lt.	1	----	----	----	2148 838	
	(code 516) Rt.	1	----	----	----	2148 833	
	Lt.	1	----	----	----	2148 839	
	Y1-M (cover) (code 553)	1	----	2149 166			
	(codes 555, 565)	1	----	2149 167			
	(code 556)	1	----	2149 168			
	(codes 557, 567)	1	----	2149 169			
	Y1-M (panel) (code 553) Rt.	1	----	----	----	2148 840	2148 840
	Lt.	1	----	----	----	2148 844	2148 844
	(code 555) Rt.	1	----	----	----	2148 841	2148 841
	Lt.	1	----	----	----	2148 845	2148 845
	(code 556) Rt.	1	----	----	----	2148 842	2148 842
	Lt.	1	----	----	----	2148 846	2148 846
	(code 557) Rt.	1	----	----	----	2148 843	2148 843
	Lt.	1	----	----	----	2148 847	2148 847
	Y1-H (panel) (code 521)	1	----	2149 333			
	(code 522)	1	----	2149 334			
	(code 523)	1	----	2149 335			
	(codes 524, 534)	1	----	2149 336			
23-108-66	COVER, Seat Cushion Frame Center Stanchion (paint as required)						
	C2-M (black)	1	----	2172 848-9	----	2172 848-9	2172 848-9

★ Indicates use as required.

☐ Indicates parts not listed in any previous parts book.

March 8, 1963 Supersedes May 1, 1962.

Printed in U.S.A.

Prices and specifications subject to change without notice.

Right and left part numbers are on same line,

first number is right, second number is left.

* Indicates change or addition.

CODE	REMARKS	PER CAR	SED.	SP. 4 D.	SUB.	SP. CL. CP.	CV. CP.
23-109-3	BACK, Rear Seat - Cont'd						
	C2-M, C2-H (code 413)	1	----	2131 883			
	(code 414)	1	----	2131 884			
	(code 415)	1	----	2131 885			
	(code 464)	1	----	2132 751			
	(code 465)	1	----	2132 126			
	C1-L, C3-H, (Sub. 2nd seat)						
	(codes 403, 423)	1	----	----	2132 592		
	(codes 404, 424)	1	----	----	2131 956		
	(codes 405, 425)	1	----	----	2131 956		
	C1-L, C3-H, (Sub. 3rd seat)						
	(codes 403, 423)	1	----	----	2132 596		
	(codes 404, 424)	1	----	----	2131 968		
	(codes 405, 425)	1	----	----	2131 969		
	C2-M (code 453)	1	----	2132 943			
	(code 454)	1	----	2132 944			
	(code 455)	1	----	2132 945			
	C2-M (code 453)	1	----	----	----	2132 155	2132 442
	(code 454)	1	----	----	----	2132 156	2132 443
	(code 455)	1	----	----	----	2132 157	2132 444
	(code 463)	1	----	----	----	2132 666-7	
		2	----	----	----	----	2132 803
	C1-L (code 401)	1	----	----	----	2132 736	2131 934
	(code 404)	1	----	*2131 884	----	2132 737	2131 935
	(code 405)	1	----	*2131 885	----	2132 738	2131 936
	Y1-L (spring and cover)						
	(code 501)	1	----	2148 639	----	2148 734	
	(code 502)	1	----	2148 640	----	2148 735	
	(code 503)	1	----	2148 641	----	2148 736	
	(code 504)	1	----	2148 642	----	2148 737	
	Y1-M (code 511)						
	(code 512)	1	----	2149 250			
	(code 513)	1	----	2149 251			
	(code 514)	1	----	2149 252			
	(code 515)	1	----	2149 253			
	(code 516)	1	----	2149 254			
	(code 516)	1	----	2149 255			
	(code 553)	1	----	2149 256	----	----	2149 100
	(code 555)	1	----	2149 257	----	----	2149 101
	(code 556)	1	----	2149 258	----	----	2149 102
	(code 557)	1	----	2149 259	----	----	2149 103
	(code 565)	1	----	2149 936			
	(code 567)	1	----	2149 937			
	Y1-H (code 521)						
	(code 522)	1	----	2149 906			
	(code 523)	1	----	2149 293			
	(code 524)	1	----	2149 294			
	(code 524)	1	----	2149 295			
	(code 534)	1	----	2149 292			
	Y1-M (code 511)						
	(code 512)	1	----	----	----	2149 036	
	(code 513)	1	----	----	----	2149 037	
	(code 514)	1	----	----	----	2149 038	
	(code 515)	1	----	----	----	2149 039	
	(code 516)	1	----	----	----	2149 040	
	(code 516)	1	----	----	----	2149 041	
	(code 553)	1	----	----	----	2149 042	

★ Indicates use as required.

☐ Indicates parts not listed in any previous parts book.
March 8, 1963 Supersedes May 1, 1962.Prices and specifications subject to change without notice.
Right and left part numbers are on same line,
first number is right, second number is left.

* Indicates change or addition.

CODE	REMARKS	PER CAR	SED.	SP. 4 D.	SUB.	SP. CL. CP.	CV. CP.
23-109-3	BACK, Rear Seat - Cont'd Y1-M (code 555) (code 556) (code 557)	1 1 1	---- ---- ----	---- ---- ----	---- ---- ----	*2149 043 2149 044 2149 045	
23-109-4	COVER, Rear Seat Back C1-L (code 301) (code 302) (code 308) (code 303) (code 304) (code 305)	1 1 1 1 1 1	2131 505 2132 877 2132 878 2131 506 2131 507 2131 508	2131 505 2132 877 2132 878 2131 506 2131 507 2131 508	---- ---- ---- ---- ---- ----	2131 582 2132 916 2132 917 2131 583 2131 584 2131 585	
	C1-L (code 341) (code 343) (code 344) (code 345) C3-H (code 331) (code 333) (code 334) (code 335) (code 465)	1 1 1 1 1 1 1 1 1	*2144 300 *2144 301 *2144 302 *2144 303 2132 290 2132 291 2132 292 2132 293 ----	*2144 300 *2144 301 *2144 302 *2144 303 2132 290 2132 291 2132 292 2132 293 2132 127	---- ---- ---- ----	*2144 344 *2144 345 *2144 346 *2144 347	
	C2-M (code 313) (code 314) (code 315) C2-M (code 413) (code 414) (code 415) C1-L (code 444) C1-L, C3-H, (Sub. 2nd seat) (codes 403, 423) (codes 404, 424) (codes 405, 425)	1 1 1 1 1 1 1 1 1 1 1	---- ---- ---- ---- ---- ---- 2132 774 ---- ---- ----	2131 742 2131 743 2131 744 2131 886 2131 887 2131 888	---- ---- ---- ---- ---- ----	2131 819 2131 820 2131 821	
	C1-L, C3-H, (Sub. 3rd seat) (codes 403, 423) (codes 404, 424) (codes 405, 425) C2-M (code 453) (code 454) (code 455) (code 463) (code 464)	1 1 1 1 1 1 2 1	---- ---- ---- ---- ---- ---- ---- ---- 2132 752	---- ---- ---- 2132 946 2132 947 2132 948 ---- 2132 752	2132 597 2131 971 2131 972 ---- ---- ---- ---- ----	2132 158 2132 159 2132 160 2132 668	2132 445 2132 446 2132 447 2132 804
	C1-L (code 401) (code 404) (code 405) Y1-L (code 501) (code 502) (code 503) (code 504)	1 1 1 1 1 1 1	---- ---- ---- ---- ---- ---- ----	*2131 887 *2131 888 2148 635 2148 636 2148 637 2148 638	---- ---- ---- ---- ---- ----	2132 738 2132 739 2132 740 2148 730 2148 731 2148 732 2148 733	2131 937 2131 938 2131 939
	Y1-M (code 511) (code 512) (code 513) (code 514) (code 515) (code 516)	1 1 1 1 1 1	---- ---- ---- ---- ---- ----	2149 240 2149 241 2149 242 2149 243 2149 244 2149 245	---- ---- ---- ---- ---- ----	2149 026 2149 027 2149 028 2149 029 2149 030 2149 031	
	Y1-H (code 521) (code 522) (code 523) (code 524) (code 534)	1 1 1 1 1	---- ---- ---- ---- ----	2149 909 2149 288 2149 289 2149 290 2149 287			

★ Indicates use as required.
 ☐ Indicates parts not listed in any previous parts book.
 Right and left part numbers are on same line,
 first number is right, second number is left.
 * Indicates change or addition.

1962 PASSENGER CAR PARTS CATALOG

INTERIOR TRIM

CODE	REMARKS	PER CAR	SED.	SP. 4 D.	SUB.	SP. CL. CP.	CV. CP.
23-109-4	COVER, Rear Seat Back - Cont'd						
	Y1-M (code 553)	1	----	2149 246	----	2149 032	2149 096
	(code 555)	1	----	2149 247	----	2149 033	2149 097
	(code 556)	1	----	2149 248	----	2149 034	2149 098
	(code 557)	1	----	2149 249	----	2149 035	2149 099
	(code 565)	1	----	2149 938			
(code 567)	1	----	2149 939				
23-109-5	PANEL, Back of Rear Seat						
	Back						
	C1-L, C3-H,(Sub. 2nd seat)	1	----	----		2169 947	
	(codes 403, 404, 405)(gray)						
	(codes 404, 405)(floor pan cover)	1	----	----		2132 478	
	(codes 403, 423)(floor pan cover)	1	----	----		2132 584	
	(code 423)(insert)(cordovan)	1	----	----		2178 635	
	(codes 424, 425)(black)	1	----	----		2176 435	
	(to rear floor pan)	1	----	----		2176 432	
	(floor pan cover)	1	----	----		2132 478	
	(code 423)(insert)(to rear floor pan)	1	----	----		2178 638	
	C1-L, C3-H,(Sub. 3rd seat)	1	----	----		2169 949	
	(codes 403, 404, 405)(insert)						
	(gray)	1	----	----		2176 433	
	(codes 424, 425)(insert)	1	----	----		2178 637	
	(black)	1	----	----		----	2149 104
	(code 423)(panel)(cordovan)	1	----	----		----	2149 105
	Y1-M (code 553)	1	----	----		----	2149 106
(code 555)	1	----	----		----	2149 107	
(code 556)	1	----	----		----		
(code 557)	1	----	----		----		
23-109-35	CUSHION, Rear Seat						
	C1-L (code 301)	1	2131 509	2131 509	----	2131 586	
	(code 302)	1	2132 879	2132 879	----	2132 918	
	(w/airfoam)	1	2132 887	2132 887	----	2132 926	
	(code 308)	1	2132 880	2132 880	----	2132 919	
	(w/airfoam)	1	2132 888	2132 888	----	2132 927	
	(code 303)	1	2131 510	2131 510	----	2131 587	
	(code 304)	1	2131 511	2131 511	----	2131 588	
	(code 305)	1	2131 512	2131 512	----	2131 589	
	C1-L (w/airfoam pad)						
	(code 301)	1	2131 541	2131 541	----	2131 618	
	(code 303)	1	2131 542	2131 542	----	2131 619	
	(code 304)	1	2131 543	2131 543	----	2131 620	
	(code 305)	1	2131 544	2131 544	----	2131 621	
	C1-L (code 341)	1	*2144 304	*2144 304	----	*2144 348	
	(code 343)	1	*2144 305	*2144 305	----	*2144 349	
	(code 344)	1	*2144 306	*2144 306	----	*2144 350	
	(code 345)	1	*2144 307	*2144 307	----	*2144 351	
	C1-L (w/airfoam pad)						
	(code 341)	1	*2144 372	*2144 372	----	*2144 400	
	(code 343)	1	*2144 373	*2144 373	----	*2144 401	
	(code 344)	1	*2144 374	*2144 374	----	*2144 402	
	(code 345)	1	*2144 375	*2144 375	----	*2144 403	
	C1-L (police)						
(code 301)	1	2132 796					
(code 303)	1	2132 797					
(code 304)	1	2132 798					
(code 305)	1	2132 799					
(code 444)	1	2132 775					

★ Indicates use as required.

Page IT-178

Printed in U.S.A.

Ⓛ Indicates parts not listed in any previous parts book.
 March 8, 1963 Supersedes May 1, 1962.

Prices and specifications subject to change without notice.
 Right and left part numbers are on same line,
 first number is right, second number is left.

* Indicates change or addition.

CODE	REMARKS	PER CAR	SED.	SP. 4 D.	SUB.	SP. CL. CP.	CV. CP.
23-109-35	CUSHION, Rear Seat - Cont'd						
	C1-L (police) (w/airfoam pad)						
	(code 301)	1	2132 805				
	(code 303)	1	2132 806				
	(code 304)	1	2132 807				
	(code 305)	1	2132 808				
	(code 444)	1	2132 787				
	C3-H (code 331)	1	2132 311	2132 311			
	(code 333)	1	2132 312	2132 312			
	(code 334)	1	2132 313	2132 313			
	(code 335)	1	2132 314	2132 314			
	C2-M (code 313)	1	----	2131 745	----	2131 822	
	(code 314)	1	----	2131 746	----	2131 823	
	(code 315)	1	----	2131 747	----	2131 824	
	(code 413)	1	----	2131 889			
	(code 414)	1	----	2131 890			
	(codes 415, 465)	1	----	2131 891			
	C1-L, C3-H, (Sub. 2nd seat)						
	(codes 403, 423)	1	----	----	2132 594		
	(codes 404, 424)	1	----	----	2131 962		
	(codes 405, 425)	1	----	----	2131 963		
	C1-L, C3-H (Sub. 3rd. seat)						
	(codes 403, 423)	1	----	----	*2132 598		
	(codes 404, 424)	1	----	----	2131 974		
	(codes 405, 425)	1	----	----	2131 975		
	C2-M (code 453)	1	----	2132 949	----	2132 161	2132 448
	(code 454)	1	----	2132 950	----	2132 162	2132 449
	(code 455)	1	----	2132 951	----	2132 163	2132 450
	(code 463)	1	----	----	----	2132 670-1	2132 670-1
	C1-L (code 401)	1	----	----	----	----	2131 940
	(code 404)	1	----	*2131 890	----	2132 741	2131 941
	(code 405)	1	----	*2131 891	----	2132 742	2131 942
	Y1-L (code 501)	1	----	2148 631	----	2148 710	
	(code 502)	1	----	2148 632	----	2148 711	
	(code 503)	1	----	2148 633	----	2148 712	
	(code 504)	1	----	2148 634	----	2148 713	
	Y1-M (code 511)	1	----	2149 230	----	2148 984	
	(code 512)	1	----	2149 231	----	2148 985	
	(code 513)	1	----	2149 232	----	2148 986	
	(code 514)	1	----	2149 233	----	2148 987	
	(code 515)	1	----	2149 234	----	2148 988	
	(code 516)	1	----	2149 235	----	2148 989	
	Y1-H (code 521)	1	----	2149 908			
	(code 522)	1	----	2149 308			
	(code 523)	1	----	2149 309			
	(code 524)	1	----	2149 310			
	(code 534)	1	----	2149 307			
	Y1-M (code 553)	1	----	2149 236	----	2148 994	2149 092
	(codes 555, 565)	1	----	2149 237	----	2148 995	2149 093
	(code 556)	1	----	2149 238	----	2148 996	2149 094
	(codes 557, 567)	1	----	2149 239	----	2148 997	2149 095
23-109-36	COVER, Rear Seat Cushion						
	C1-L (code 301)	1	2131 513	2131 513	----	2131 590	
	(code 302)	1	2132 881	2132 881	----	2132 920	
	(code 303)	1	2131 514	2131 514	----	2131 591	
	(code 304)	1	2131 515	2131 515	----	2131 592	
	(code 305)	1	2131 516	2131 516	----	2131 593	
	(code 308)	1	2132 882	2132 882	----	2132 921	

★ Indicates use as required.

□ Indicates parts not listed in any previous parts book.

Right and left part numbers are on same line, first number is right, second number is left.

* Indicates change or addition.

1962 PASSENGER CAR PARTS CATALOG

INTERIOR TRIM

CODE	REMARKS	PER CAR	SED.	SP. 4 D.	SUB.	SP. CL. CP.	CV. CP.
23-109-36	COVER, Rear Seat Cushion - Cont'd						
	C1-L (code 341)	1	*2144 308	*2144 308	----	*2144 352	
	(code 343)	1	*2144 309	*2144 309	----	*2144 353	
	(code 344)	1	*2144 310	*2144 310	----	*2144 354	
	(code 345)	1	*2144 311	*2144 311	----	*2144 355	
	C3-H (code 331)	1	2132 315	2132 315			
	(code 333)	1	2132 316	2132 316			
	(code 334)	1	2132 317	2132 317			
	(code 335)	1	2132 318	2132 318			
	C2-M, C3-H,(code 313)	1	----	2131 748	----	2131 825	
	(code 314)	1	----	2131 749	----	2131 826	
	(code 315)	1	----	2131 750	----	2131 827	
	(code 413)	1	----	2131 892			
	(code 414)	1	----	2131 893			
	(codes 415, 465)	1	----	2131 894			
	C1-L, C3-H,(Sub. 2nd seat)						
	(codes 403, 423)	1	----	----	2132 595		
	(codes 404, 424)	1	----	----	2131 965		
	(codes 405, 425)	1	----	----	2131 966		
	C1-L, C3-H,(Sub. 3rd seat)						
	(codes 403, 423)	1	----	----	2132 599		
	(codes 404, 424)	1	----	----	2131 977		
	(codes 405, 425)	1	----	----	2131 978		
	C2-M (code 453)	1	----	2132 952	----	2132 164	2132 451
	(code 454)	1	----	2132 953	----	2132 165	2132 452
	(code 455)	1	----	2132 954	----	2132 166	2132 453
	(code 463)	1	----	----	----	2132 672-3	2132 672-3
	C1-L (code 401)	1	----	----	----	2132 742	2131 943
	(code 404)	1	----	*2131 893	----	2132 743	2131 944
	(code 405)	1	----	*2131 894	----	2132 744	2131 945
	(code 444) (Police)	1	2132 776				
	Y1-L (code 501)	1	----	2148 627	----	2148 706	
	(code 502)	1	----	2148 628	----	2148 707	
	(code 503)	1	----	2148 629	----	2148 708	
	(code 504)	1	----	2148 630	----	2148 709	
	Y1-M (code 511)	1	----	2149 220	----	2148 978	
	(code 512)	1	----	2149 221	----	2148 979	
	(code 513)	1	----	2149 222	----	2148 980	
	(code 514)	1	----	2149 223	----	2148 981	
	(code 515)	1	----	2149 224	----	2148 982	
	(code 516)	1	----	2149 225	----	2148 983	
	Y1-H (code 521)	1	----	2149 911			
	(code 522)	1	----	2149 303			
	(code 523)	1	----	2149 304			
	(code 524)	1	----	2149 305			
	(code 534)	1	----	2149 302			
	Y1-M (code 553)	1	----	2149 226	----	2148 990	2149 088
	(codes 555, 565)	1	----	2149 227	----	2148 991	2149 089
	(code 556)	1	----	2149 228	----	2148 992	2149 090
	(codes 557, 567)	1	----	2149 229	----	2148 993	2149 091
23-109-38	RETAINER, Center Floor Pan Rear Seat Cushion						
	C1, C2, C3, Y1	2	1810 037	1810 037	----	1810 037	1810 037
23-109-40	INSERT, Rear Seat Cushion Bottom Panel						
	C1-L (codes 403, 404, 405)(gray)	1	----	----	2169 948		
	(codes 424, 425)(black)	1	----	----	2176 434		
	(code 423) (cordovan)	1	----	----	2178 636		

★ Indicates use as required.

⊠ Indicates parts not listed in any previous parts book.

March 8, 1963 Supersedes May 1, 1962.

Prices and specifications subject to change without notice.

Right and left part numbers are on same line,

first number is right, second number is left.

* Indicates change or addition.

CODE	REMARKS	PER CAR	SED.	SP. 4 D.	SUB.	SP. CL. CP.	CV. CP.
23-111-10	STRIP, Front Pillar Upper Tacking Y1	2	----	1878 174	----	1878 174	1878 174
23-111-30	STRIP, Folding Top Header Front Tacking Y1 (side)	1 2	----	----	----	----	1750 628 1691 923
23-111-31	RETAINER, Folding Top Header Outer Panel Tacking Strip C1, C2, C3	1	----	----	----	----	1952 194
23-111-37	STRIP, Folding Top Bow Tacking C1, C2, C3 (No. 1 Bow) (No. 2 Bow) (Rear Bow) Y1 (Front Bow) (Center Bow)	2 2 1 2 2	----	----	----	----	1950 509 1950 509 1950 510 1691 901 1691 901
23-112-12	BOOT, Folding Top Dust C1-L, C2-M (with rear seat back channel insert, 5/8" wide) (code 401) (blue) (codes 404, 454) (black) (codes 405, 455) (red) (codes 453, 463) (tan) (with seaming welt filler, 1/4" dia.) (code 401) (blue) (codes 404, 454) (black) (codes 405, 455) (red) (codes 453, 463) (tan) Y1-M (code 553)(w/o pleats in center cover) (code 555) (code 556) (code 557) Y1-M (w/pleats in center cover) (code 553) (code 555) (code 556) (code 557)	1 1 1 1 1 1 1 1 1 1 1 1	----	----	----	----	*2177 925 *2177 926 *2177 927 *2178 844 *2178 446 *2178 447 *2178 448 *2178 449 2177 545 2177 546 2175 154 2177 547 2178 884 2178 885 2178 886 2178 887
23-112-18	RETAINER, Channel Rear Seat Back Dust Boot C1, C2 (for large insert) Y1 (for large insert) (attaching screw) C1, C2 (for small insert) Y1 (for small insert)	1 1 8 1 1	----	----	----	----	*2160 567 *1969 619 *9415 552 *2410 007 *2410 009
23-112-19	INSERT, Rear Seat Dust Boot Cover Y1-M	1	----	----	----	----	2160 328
23-112-21	FASTENER and PLATE, Folding Dust Boot C1, C2	23	----	----	----	----	*2193 035
23-112-33	EXTENSION, Folding Top Pocket Panel C2-M	1	----	----	----	----	2178 420-1

★ Indicates use as required.
 ☐ Indicates parts not listed in any previous parts book.
 Right and left part numbers are on same line, first number is right, second number is left.
 * Indicates change or addition.

1962 PASSENGER CAR PARTS CATALOG

INTERIOR TRIM

CODE	REMARKS	PER CAR	SED.	SP. 4 D.	SUB.	SP. CL. CP.	CV. CP.
23-112-45	CURTAIN, Folding Top Back C1-L, C2-M, (codes 401, 404, 405, 453, 455, 456) (black (white) Y1-M (codes 553, 555, 556, 557) (black) (white)	1	----	----	----	----	2178 802
		1	----	----	----	----	2178 803
		1	----	----	----	----	2172 104
		1	----	----	----	----	2177 530
23-112-46	ZIPPER, Folding Top Rear Curtain C1-L, C2-M (codes 401, 404, 405, 453, 454, 455, 456, 463) (black) Y1-M (codes 553, 555, 556, 557) (black)	1	----	----	----	----	1965 887
		1	----	----	----	----	2172 107
23-112-70	RETAINER, Folding Top to Belt Bar Side C1, C2 (galvanized) (finished) (center)(galvanized) (inner) Y1 (at belt)	1	----	----	----	----	2165 706-7
		1	----	----	----	----	2165 706-7
		1	----	----	----	----	1963 550
		2	----	----	----	----	2216 421
		2	----	----	----	----	1877 746-7
		2	----	----	----	----	2094 354
23-112-75	TIP, Folding Top Wire-on Binding End C1-L, C2-M, Y1-M	1	----	----	----	----	1158 976-7
23-112-88	PACKAGE, Folding Top Rear Bow Tension Cable C1, C2 Y1 (to wheelhouse bracket) (to bar bolt)	2	----	----	----	----	2166 659
		1	----	----	----	----	1810 118
		1	----	----	----	----	2166 660
23-112-108	DECK and SIDE QUARTER, Folding Top C1-L, C2-M (codes 401, 404, 405, 453, 454, 455, 463)(black) (white) Y1-M (codes 553, 555, 556, 557) (black) (white)	1	----	----	----	----	2178 404
		1	----	----	----	----	2178 405
		1	----	----	----	----	2171 895
		1	----	----	----	----	2177 534
23-112-112	PAD, Folding Top Side Quarter Stay C1-L, C2-M (codes 401, 404, 405, 453, 454, 455, 463) (black) Y1-M (codes 553, 555, 556, 557) (black)	1	----	----	----	----	2178 796-7
		1	----	----	----	----	2172 100-1
23-112-153	PANEL, Rear Quarter Pocket C1-L, C2-M (code 401) (codes 453, 463) (codes 404, 454) (codes 405, 455) (pocket panel cover) (code 401) (code 453) (codes 404, 454) (codes 405, 455)	1	----	----	----	----	2132 086-7
		1	----	----	----	----	2132 537-8
		1	----	----	----	----	2132 088-9
		1	----	----	----	----	2132 090-1
		1	----	----	----	----	2132 092-3
		1	----	----	----	----	2132 402-3
		1	----	----	----	----	2132 094-5
		1	----	----	----	----	2132 096-7

★ Indicates use as required.

Page IT-182

Printed in U.S.A.

☐ Indicates parts not listed in any previous parts book.
March 8, 1963 Supersedes May 1, 1962.

Prices and specifications subject to change without notice.
Right and left part numbers are on same line,
first number is right, second number is left.

* Indicates change or addition.

CODE	REMARKS	PER CAR	SED.	SP. 4 D.	SUB.	SP. CL. CP.	CV. CP.	
23-112-153	PANEL, Rear Quarter Pocket - Cont'd C1-L, C2-M (folding top well) (code 401) (codes 453, 463) (codes 404, 454) (codes 405, 455) (rear quarter pocket shelf panel)(code 401) (codes 453, 463) (codes 404, 454) (codes 405, 455)	1 1 1 1 1 1 1 1	---- ---- ---- ---- ---- ---- ---- ----	---- ---- ---- ---- ---- ---- ---- ----	---- ---- ---- ---- ---- ---- ---- ----	---- ---- ---- ---- ---- ---- ---- ----	---- ---- ---- ---- ---- ---- ---- ----	2178 792 *2178 411 2178 794 2178 795 2132 080-1 2132 498-9 2132 082-3 2132 084-5
Y1-M	(pocket panel)(code 553) (code 555) (code 556) (code 557) (pocket panel cover) (code 553) (code 555) (code 556) (code 557)	1 1 1 1 1 1 1 1	---- ---- ---- ---- ---- ---- ---- ----	---- ---- ---- ---- ---- ---- ---- ----	---- ---- ---- ---- ---- ---- ---- ----	---- ---- ---- ---- ---- ---- ---- ----	---- ---- ---- ---- ---- ---- ---- ----	2149 080-1 2149 082-3 2149 084-5 2149 086-7 2149 072-3 2149 074-5 2149 076-7 2149 078-9
Y1-M	(folding top well) (code 553) (code 555) (codes 556, 557)	1 1 1	---- ---- ----	---- ---- ----	---- ---- ----	---- ---- ----	---- ---- ----	2177 543 2177 544 2176 441
23-113-2	WEATHERCORD, Door (order by color) C1, C2, C3 (blue) (cocoa) (gray) (red) (tan) (black) (codes 302, 308)	★ ★ ★ ★ ★ ★	2178 601 2178 602 2178 603 2178 604 *2178 831 *2163 695	2178 601 2178 602 2178 603 2178 604 *2178 831 *2163 695	2178 601 2178 602 2178 603 2178 604 *2178 831 ----	2178 601 2178 602 2178 603 2178 604 *2178 831 *2163 695	2178 601 2178 602 2178 603 2178 604 *2178 831 *2163 695	
23-113-25	WEATHERCORD, Front Door Hinge Pillar C2-M (codes 313, 413, 453, 463) (tan) Y1 (codes 501, 511, 521)(blue) (codes 502, 512, 522)(green) (codes 503, 513, 523)(cordovan) (code 553) (tan) (codes 515, 555) (red) (codes 504, 514, 516, 524, 534, 556, 557) (black)	★ 2 2 2 2 2 ★	---- ---- ---- ---- ---- ---- ----	*2178 831 2177 376 2177 377 2177 378 2177 380 2177 379 2163 695	---- ---- ---- ---- ---- ---- ----	*2178 831 2177 376 2177 377 2177 378 2177 380 2177 379 2163 695	*2178 831 2177 376 2177 377 2177 378 2177 380 2177 379 2163 695	
23-113-30	WEATHERCORD, Door Lock Pillar C1, C2 (black) (Note: For Imperial Lock Pillar w/cord use Part Type Code 23-99-41)	★	----	----	----	2163 695	2163 695	
23-113-36	FILLER, Folding Top Bow Y1 (front and center)	1	----	----	----	----	1246 543	

★ Indicates use as required.

☐ Indicates parts not listed in any previous parts book.

Right and left part numbers are on same line, first number is right, second number is left.

* Indicates change or addition.

1962 PASSENGER CAR PARTS CATALOG

CODE	REMARKS	PER CAR	SED.	SP. 4 D.	SUB.	SP. CL. CP.	CV. CP.	
23-113-50	WELT, Windshield Side Garnish Moulding to Instrument Panel C1, C2, C3 (black) Y1-L, Y1-M, Y1-H	2	1758 241	1758 241	1758 241	1758 241	1758 241	
		1	----	*2180 666-7	----	*2180 666-7	*2180 666-7	
23-113-84	WELT, Folding Top Header C1, C2 Y1	★	----	----	----	----	2163 846	
		★	----	----	----	----	2192 739	
23-114-2	MATERIAL, Seat Cloth Trim C1-L (54") (code 301) (blue) (code 302) (green plaid) (code 303) (cocoa) (code 304) (gray and black) (code 305) (red) (code 308) (turq. plaid) (code 341) (blue) (code 343) (cocoa) (code 344) (gray & black) (code 345) (red) C3-H (63") (codes 321, 331) (blue) (codes 323, 333) (cocoa) (codes 324, 334) (gray) (code 335) C2-M (60") (code 313) (code 314) (code 315) Y1-L (67") (code 501) (blue) (code 502) (green) (code 503) (cordovan) (code 504) (black) Y1-M, Y1-H (65") (codes 511, 531) (blue) (codes 512, 522) (green) Y1-M, Y1-H (65") (code 523) (cocoa) (code 513) (cordovan) (codes 514, 524, 534) (gray) (code 515) (red) (code 516) (black) Y1-H (No. 2) (65") (code 531) (code 534)	★	*2185 297	*2185 297	----	*2185 297		
		★	2186 067	2186 067	----	2186 067		
		★	2185 298	2185 298	----	2185 298		
		★	2185 299	2185 299	----	2185 299		
		★	2185 300	2185 300	----	2185 300		
		★	2186 068	2186 068	----	2186 068		
		★	*2186 165	*2186 165	----	*2186 165		
		★	*2186 166	*2186 166	----	*2186 166		
		★	*2186 167	*2186 167	----	*2186 167		
		★	*2186 168	*2186 168	----	*2186 168		
		★	*2185 301	*2185 301				
		★	2185 302	2185 302				
		★	2185 303	2185 303				
		★	2185 304	2185 304				
		★	----	----	----	----	*2185 406	*2185 406
		★	----	----	----	----	2185 407	2185 407
		★	----	----	----	----	2185 408	2185 408
		★	----	----	*2185 349	----	*2185 349	
		★	----	----	2185 350	----	2185 350	
		★	----	----	2185 351	----	2185 351	
		★	----	----	2185 352	----	2185 352	
		★	----	----	*2185 270	----	*2185 270	
★	----	----	2185 271	----	2185 271			
★	----	----	*2185 276	----	*2185 276			
★	----	----	2185 273	----	2185 273			
★	----	----	2185 272	----	2185 272			
★	----	----	2185 274	----	2185 274			
★	----	----	2185 275	----	2185 275			
★	----	----	*2185 305	----				
★	----	----	2185 307	----				
23-114-10	BINDING, 5/8 Wire on C1-L, C2-M, Y1-M (white) (black)	★	----	----	----	----	2177 529	
		★	----	----	----	----	2171 884	
23-114-14	HIDE, Leather C2-M (code 453) (tan) (code 454) (black) (code 455) (red)	★	----	----	----	2185 206	2185 206	
		★	----	----	----	1874 607	1874 607	
★	----	----	----	----	2185 237	2185 237		
★	Y1-M (codes 511, 521) (blue)	★	----	2185 189	----	2185 189		
★	(codes 512, 522) (green)	★	----	2185 190	----	2185 190		
★	(code 553) (tan)	★	----	2185 206	----	2185 206	2185 206	
★	(codes 514, 524) (gray)	★	----	2185 192	----	2185 192		
★	(codes 515, 555) (red)	★	----	2185 193	----	2185 193	2185 193	
★	(codes 516, 556) (black)	★	----	1912 660	----	1912 660	1912 660	
★	(code 557) (white)	★	----	2185 207	----	2185 207	2185 207	

★ Indicates use as required.

⊠ Indicates parts not listed in any previous parts book.

March 8, 1963 Supersedes May 1, 1962.

Prices and specifications subject to change without notice.

Right and left part numbers are on same line,
first number is right, second number is left.

* Indicates change or addition.

CODE	REMARKS	PER CAR	SED.	SP. 4D.	SUB.	SP. CL. CP.	CV. CP.
23-114-15	MATERIAL, Leather (imitation) Trim						
	C1-L (code 302)(28-AM-22) (50")(1553 lime green) (19-C-22)	★	2186 099	2186 099	----	2186 099	
	(54")(1553 lime green) (17-C-81)	★	2186 101	2186 101	----	2186 101	
	(54")(1553 lime green) (code 308)(28-AM-22)	★	2186 103	2186 103	----	2186 103	
	(50")(1554 turq.) (19-C-22)	★	2186 100	2186 100	----	2186 100	
	(54")(1554 turq.) (17-C-81)	★	2186 102	2186 102	----	2186 102	
	(54")(1554 turq.)	★	2186 104	2186 104	----	2186 104	
	(codes 302, 308)(28A-AM-22) (50")(1220-1 black frost) (19A-C-22)	★	1875 018	1875 018	----	1875 018	
	(54")(1220-1 black frost) C1-L, C2-M (codes 301, 331, 341, 401)	★	1874 975	1874 975	----	1874 975	
	(28-AM-46) (50")(1501-1 blue)	★	----	----	*2185 177	----	*2185 177
	(28-AM-22) (50")(1501-1 blue)	★	2185 141	2185 141	----	2185 141	
	(24-CK-22) (54")(1501-1 blue)	★	2185 578	----	2185 366	----	2185 366
	(22-AR-22) (54")(1501-1 blue)	★	2185 320	2185 320	----	----	
	(19A-C-22) (54")(1501-1 blue)	★	2185 147	2185 147	----	2185 147	
	(19B-C-22) (54")(1502-1 blue)	★	2185 164	----	2185 164	----	2185 164
	(19-C-22) (54")(1501-1 blue)	★	2185 147	2185 147	----	2185 147	
	C1-L, C2-M, C3-H (codes 303, 313, 333, 343, 403, 413 423, 453, 463)						
	(28-AM-46) (50")(1524 tan)	★	----	*2185 526			
	(code 403) (1504-1 cocoa)	★	----	----	2185 518	----	2185 518
	(28-AM-22) (50")(1504-1 cocoa) (codes 313, 413, 453, 463)	★	2185 142	2185 142	2185 142	2185 142	
	(1524 tan)	★	----	2185 194	----	2185 194	2185 194
	(24-CK-22) (54")(1504-1 cocoa) (codes 313, 413, 453, 463)	★	2185 544	2185 544	----	2185 544	
	(1524 tan)	★	----	2185 842	----	2185 842	
	(22-AR-22) (54")(1504-1 cocoa)	★	2185 842	2185 842	2185 842	----	
	(19A-C-22) (54")(1504-1 cocoa)	★	2185 148	2185 148	----	2185 148	
	(codes 313, 453, 463) (1514 tan)	★	----	2185 201	----	2185 201	2185 201
	(codes 403, 423) (1511 gray)	★	----	----	2185 157	----	
	(19B-C-22) (54")(415 black)	★	1874 974	1874 974	1874 974	1874 974	1874 974
	(code 463) (1528-1 tan)	★	----	----	----	2185 197	2185 197
	(codes 333, 403) (1505-1 cordovan)	★	2185 166	2185 166	2185 166	----	
	C1-L, C2-M, C3-H (codes 304, 314, 334, 344, 404, 414, 424, 454, 455)						
	(28-AM-46) (50")(1220-1 black) (28-AM-22)	★	----	*1875 822	*1875 822	----	
	(50")(1220-1 black frost)	★	----	1875 018	1875 018	1875 018	1875 018
	(code 304) (1508-1 gray)	★	2185 143	2185 143	----	2185 143	
	(24-CK-22) (54")(1508-1 gray) (codes 404, 414, 454)	★	----	2185 598	----	2185 598	
	(1220-1 black)	★	----	1875 093	1875 093	1875 093	1875 093
	(22-AR-22) (54")(1508-1 gray)	★	2185 321	2185 321	----	----	
	(code 424) (1220-1 black)	★	----	----	2185 886	----	
	(19A-C-22) (54")(1511 gray)	★	2185 157	2185 157	2185 157	2185 157	2185 157

★ Indicates use as required.

⊞ Indicates parts not listed in any previous parts book.
Right and left part numbers are on same line,
first number is right, second number is left.

* Indicates change or addition.

1962 PASSENGER CAR PARTS CATALOG

INTERIOR TRIM

CODE	REMARKS	PER CAR	SED.	SP. 4D.	SUB.	SP. CL. CP.	CV. CP.
23-114-15	MATERIAL, Leather (imitation) Trim - Cont'd						
	C1-L, C2-M, C3-H						
	(19B-C-22) (54")(415 black)	★	1874 974	1874 974	1874 974	1874 974	1874 974
	(19-C-22) (54")(1508-1 gray) (codes 404, 414, 424, 444, 454)	★	2185 149	2185 149	----	2185 149	
	(1220-1 black) (code 444) (32-CS-22)	★	1874 975	1874 975	1874 975	----	1874 975
	(50")(902 gray)	★	2185 119				
	19 oz. (54")(1516 white) (for padded visor)	★	2185 329	----	2185 329		
	C1-L, C2-M, C3-H (codes 315, 345, 405, 415, 425, 455, 465)						
	(19-C-22) (54")(1509 red)	★	----	*2185 151	----	*2185 151	*2185 151
	(19A-C-22) (54")(1509 red)	★	----	1874 974	----	2185 151	
	(19B-C-22) (54")(415 black)	★	----	*1874 974	----	1874 974	1874 974
	(19-DS-22) (54")(1509 red)	★	----	*2185 545	----	*2185 545	*2185 545
	(28-AM-22) (50")(1509 red)	★	----	2185 150	----	2185 150	2185 150
	(28-AM-46) (50")(1509 red)	★	----	2185 178			
	(22-AR-22) (54")(1509 red)	★	----	2185 479			
	(code 463)						
	(19A-C-22) (54")(1514 tan)	★	----	----	----	2185 201	
	(19B-C-22) (54")(1528-1 tan)	★	----	----	----	2185 197	2185 197
	(24-CK-22) (54")(1524 tan)	★	----	----	----	2185 523	2185 523
	(28-AM-22) (50")(1524 tan)	★	----	----	----	2185 194	2185 194
	Y1-L, Y1-M, Y1-H (codes 501, 511, 521)						
	(28A-AM-22) (50")(1502-1 blue)	★	----	2185 148	----	2185 148	
	(28-AM-22) (50")(1501-1 blue)	★	----	2185 141	----	2185 141	
	(22-AR-22) (54")(1501-1 blue)	★	----	2185 320	----	2185 320	
	(19A-C-22) (54")(1501-1 blue)	★	----	2185 147	----		
	(19B-C-22) (54")(1500 blue)	★	----	2185 155	----	2185 155	
	(19C-C-22) (54")(1501-1 blue)	★	----	2185 147	----	2185 147	
	(19-C-22) (54")(1502-1 blue)	★	----	2185 164	----	2185 164	
	(codes 502, 512, 522)						
	(28A-AM-22) (50")(1507-1 green)	★	----	2185 159	----	2185 159	
	(28-AM-22) (50")(1506-1 green)	★	----	2185 163	----	2185 163	
	(22-AR-22) (54")(1506-1 green)	★	----	2185 322	----	2185 322	
	(19A-C-22) (54")(1506-1 green)	★	----	2185 167	----	2185 167	
	(19B-C-22) (54")(1515 green)	★	----	2185 188	----	2185 188	
	(19C-C-22) (54")(1506-1 green)	★	----	2185 167	----	2185 167	
	(19-C-22) (54")(1502-1 green)	★	----	2185 165	----	2185 165	
	Y1-L, Y1-M, Y1-H (codes 504, 514, 524, 534)						
	(28A-AM-22) (50")(415 black)	★	----	1831 003	----	1831 003	
	(28-AM-22) (50")(1508-1 gray)	★	----	2185 143	----	2185 143	
	(22-AR-22) (54")(1508-1 gray)	★	----	2185 321	----	2185 321	
	(19A-C-22) (54")(1508-1 gray)	★	----	2185 149	----	2185 149	
	(19B-C-22) (54")(1511 gray)	★	----	2185 157	----	2185 157	
	(19C-C-22) (54")(1508-1 gray)	★	----	2185 149	----	2185 149	
	(19-C-22) (54")(415 black)	★	----	1874 974	----	1874 974	
	Y1-M (codes 515, 555)						
	(28-AM-22) (54")(1513 red)	★	----	2185 195	----	2185 195	2185 195
	(22-AR-22) (54")(1513 red)	★	----	2185 203	----	2185 203	
	(19B-C-22) (54")(1513 red)	★	----	2185 198	----	2185 198	2185 198
	(19-C-22) (54")(1513 red)	★	----	2185 198	----	2185 198	

★ Indicates use as required.

□ Indicates parts not listed in any previous parts book.

March 8, 1963 Supersedes May 1, 1962.

Page IT-186

Printed in U.S.A.

Prices and specifications subject to change without notice.

Right and left part numbers are on same line,
first number is right, second number is left.

* Indicates change or addition.

CODE	REMARKS	PER CAR	SED.	SP. 4 D.	SUB.	SP. CL. CP.	CV. CP.
23-114-15	MATERIAL, Leather (imitation) Trim - Cont'd Y1-M, Y1-H (codes 503, 513, 523, 553) (28A-AM-22) (50")(1505-1 cordovan)	★	----	2185 160	----	2185 160	
	(28-AM-22) (50")(1504-1 cocoa (code 553) (1524 tan)	★	----	2185 142	----	2185 142	
	(22-AR-22) (54")(1504-1 cocoa)	★	----	2185 194	----	2185 194	2185 194
	(19A-C-22) (54")(1504-1 cocoa)	★	----	2185 323	----	2185 323	
	(19B-C-22) (54")(1503 beige) (code 553) (1514 tan)	★	----	2185 148	----	2185 148	
	(19C-C-22) (54")(1504-1 cocoa)	★	----	2185 156	----	2185 156	
	(19-C-22) (54")(1505-1 cordovan)	★	----	2185 201	----	2185 201	
		★	----	2185 148	----	2185 148	
		★	----	2185 166	----	2185 166	
	Y1-M, Y1-H(code 553)(1528-1tan)	★	----	2185 197	----	2185 197	
	Y1-M (codes 516, 556) (28-AM-22) (54")(415 black)	★	----	1831 003	----	1831 003	1831 003
	(19B-C-22) (54")(1511 gray)	★	----	2185 157	----	2185 157	
	(19-C-22) (54")(415 black) (code 557, 567)	★	----	1874 974	----	1874 974	
	(28-AM-22) (54")(1512 white)	★	----	2185 196	----	2185 196	2185 196
	(19-C-22) (54")(415 black)	★	----	1874 974	----	1874 974	1874 974
23-115-4	NUT, Front Seat Back to Cushion Mounting C1, C2, Y1 (up to serial No. 8223-133063) (push nut) (after) (push nut not used with bucket seats)	4 4 2	----	----	----	*1918 296 *2092 246 *2160 648	*1918 296 *2092 246 *2160 648
23-115-5	WASHER, Front Seat Center Arm Rest Trim C2	2	----	----	----	1918 299	1918 299
23-115-6	SCREW, Front Seat Back to Cushion Mounting C2 (up to serial No. 8223-133063) (pin) (after)	4 4	----	----	----	*1918 587 *2410 054	*1918 587 *2410 054
23-115-10	SCREW, Front Seat Center Arm Rest to Cushion Mounting C2	2	----	----	----	2092 212	2092 212

★ Indicates use as required.
 ☐ Indicates parts not listed in any previous parts book.
 Right and left part numbers are on same line,
 first number is right, second number is left.
 * Indicates change or addition.

