

GROUP 15 - HOOD

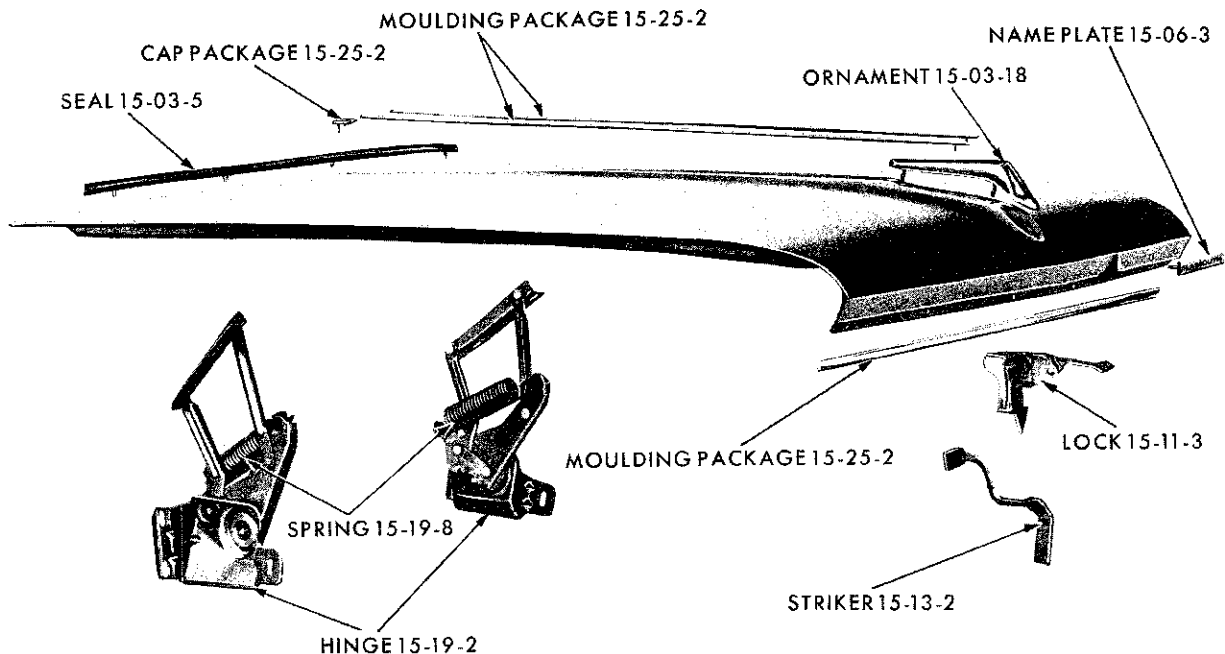

19x9234

HOOD - PLYMOUTH SP1-2

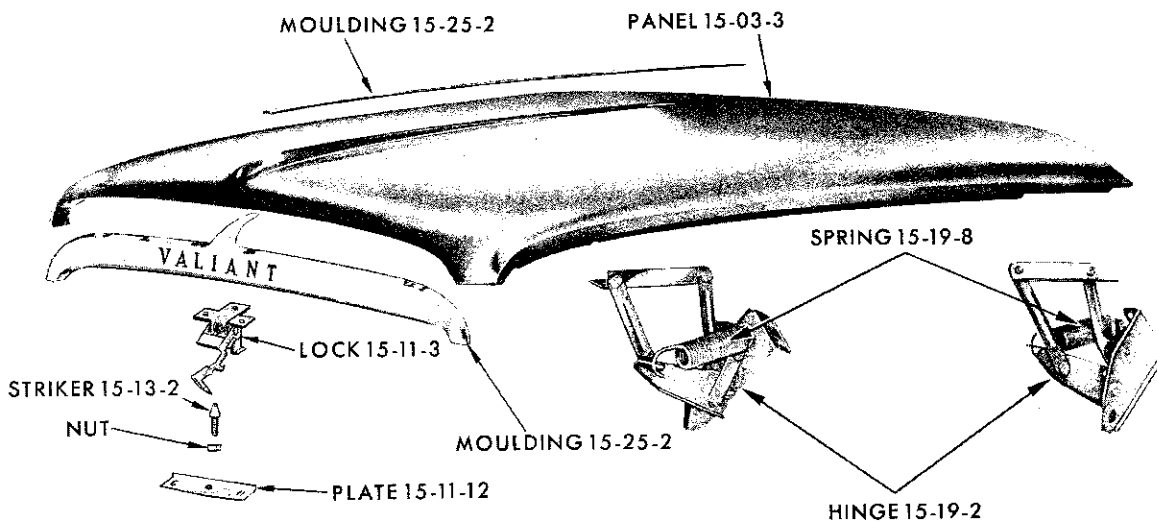

PARTS INDICATED
BY NAME ONLY - ORDER
BY DESCRIPTION

19x8740A

HOOD - VALIANT SV1

PARTS INDICATED
BY NAME ONLY - ORDER
BY DESCRIPTION

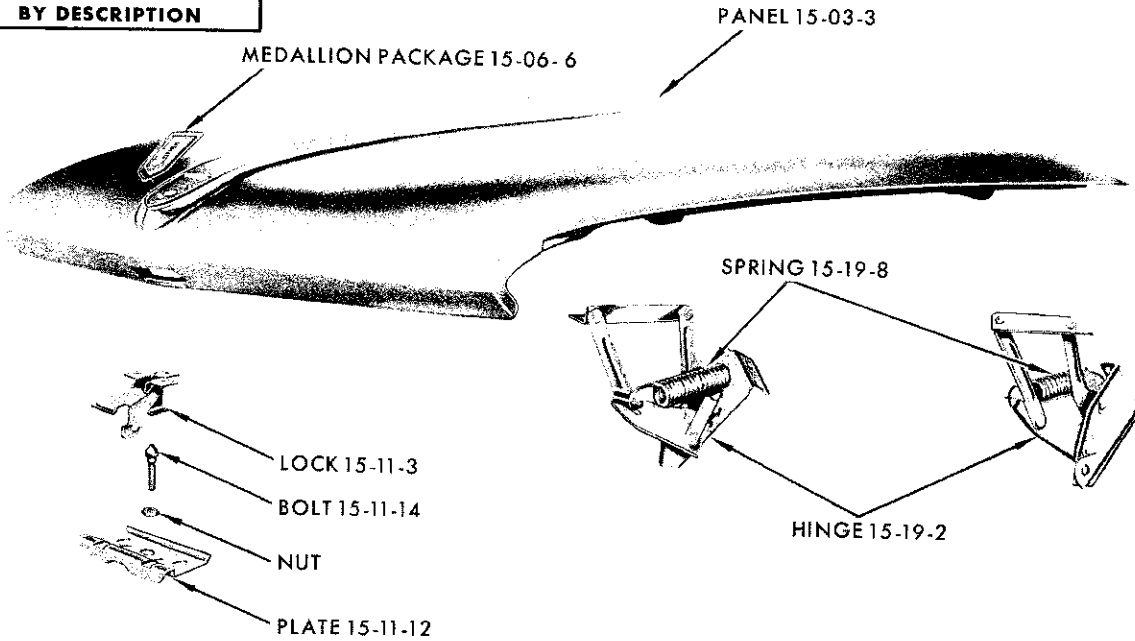

19x8987A

HOOD - LANCER SL1

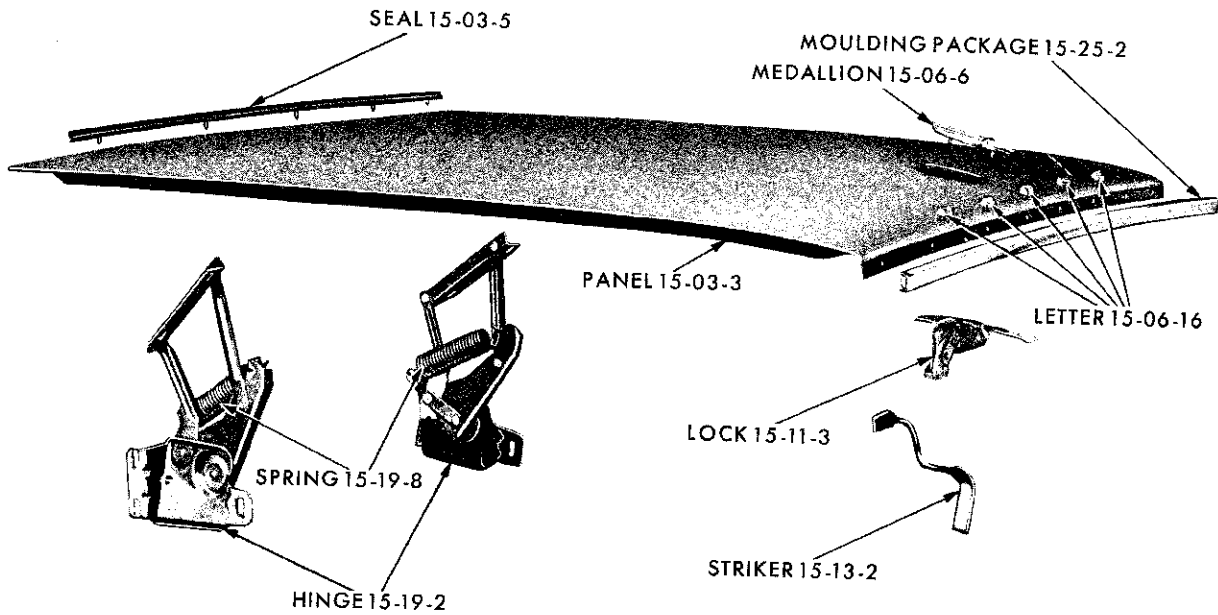

19x9233

HOOD - DODGE SD1-2

PARTS INDICATED BY NAME ONLY - ORDER BY DESCRIPTION

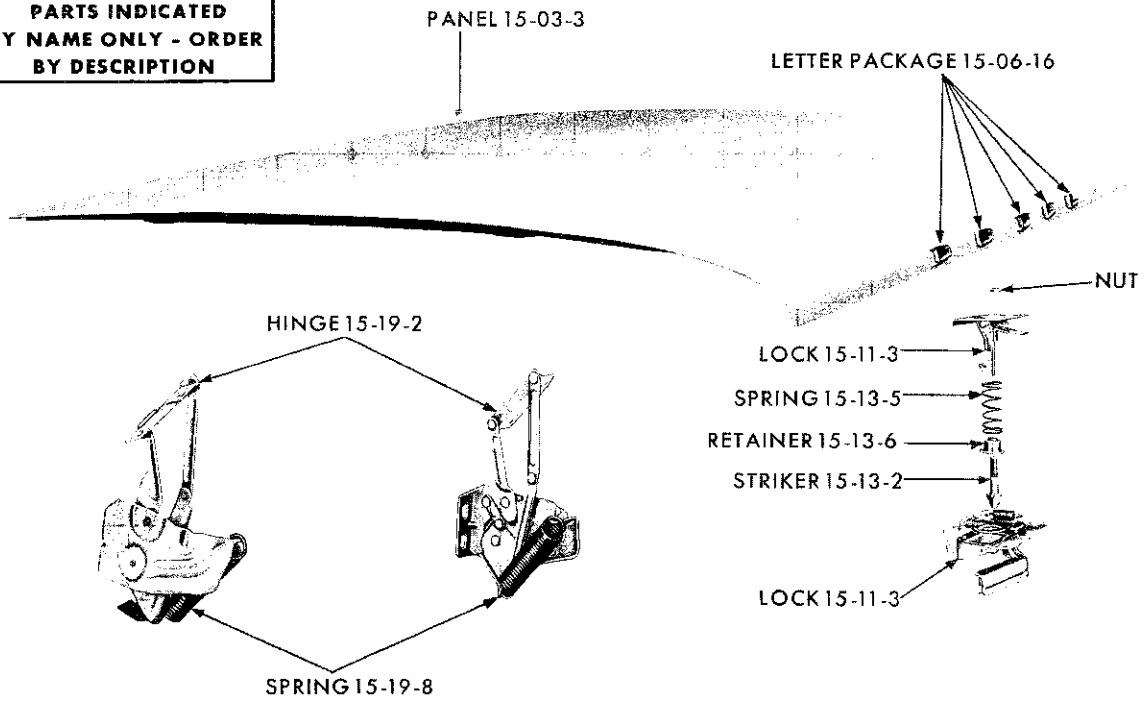

19x8977A

HOOD - DODGE SD3

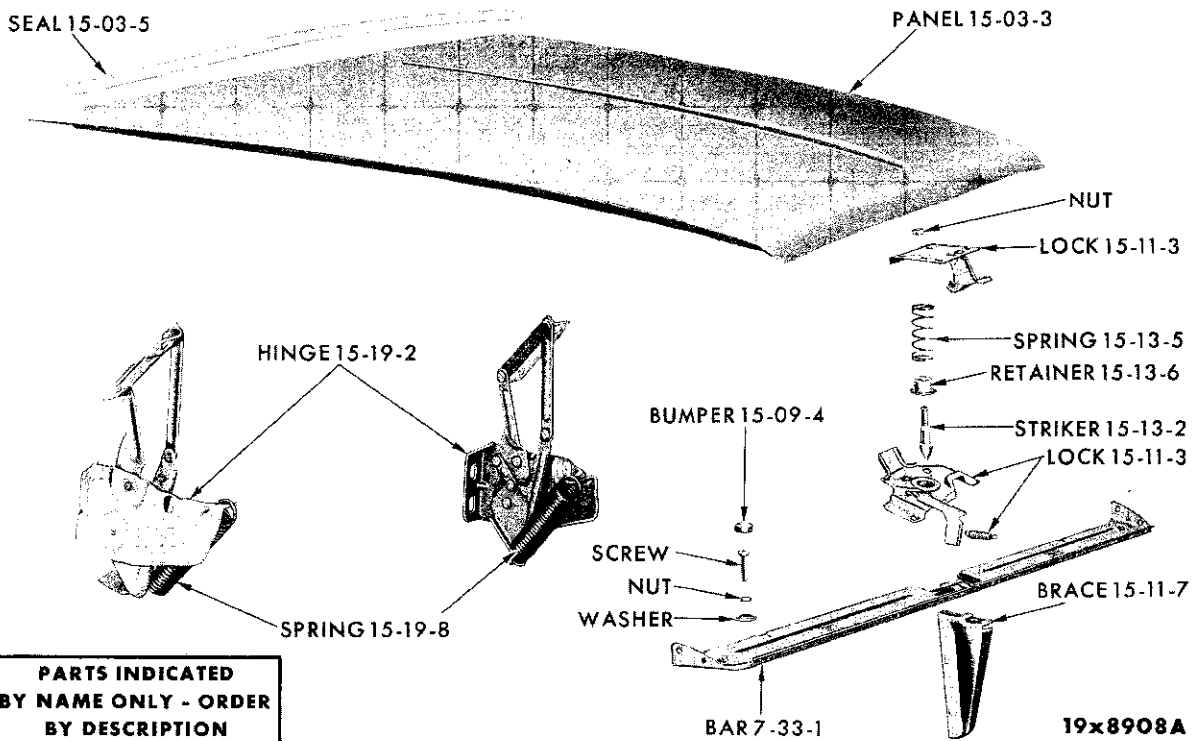

PARTS INDICATED BY NAME ONLY - ORDER BY DESCRIPTION

19x8908A

HOOD - CHRYSLER SC1-2-3

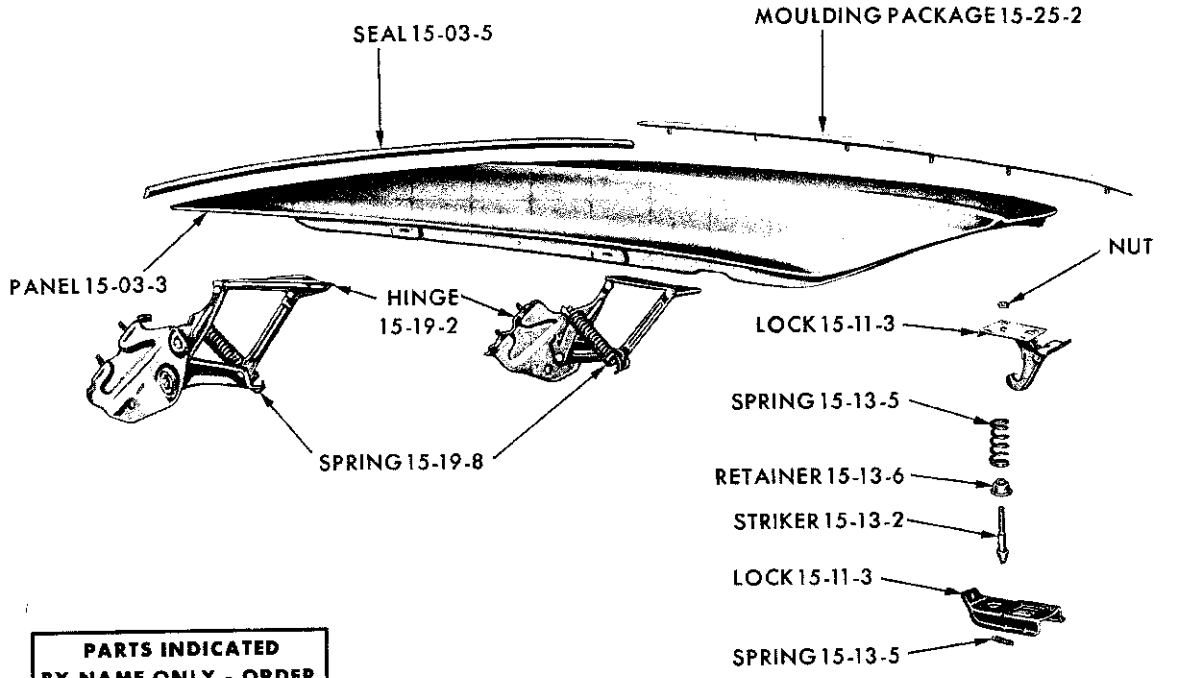

**PARTS INDICATED
BY NAME ONLY - ORDER
BY DESCRIPTION**

19x8938

HOOD - IMPERIAL SY1

NOTES

CODE	PART NAME AND DESCRIPTION	C Y L.	PER CAR	VALIANT LANCER	PLYMOUTH DODGE	CHRYSLER IMPERIAL
15-03-0 HOOD TOP PANEL						
15-03-3	PANEL, SV1	6	1	2253 159		
	SL1	6	1	2195 521		
	SP1, SP2		1	----	2099 002	
	SD1, SD2		1	----	2099 058	
	SD3	8	1	----	2417 182	
	SC1, SC2	8	1	----	----	2253 241
	SC3	8	1	----	----	2253 249
	SY1	8	1	----	----	1904 054
15-03-5	SEAL, Hood to Cowl, except SY1		1	2082 965	2217 348	2165 551
	Hood to Yoke		★	----	1242 974	1242 974
	CLIP, to Inner Panel		★	----	6010 094	
	CLIP, to Yoke	8	★	----	----	6000 070
15-03-11	REINFORCEMENT, Hood Inner Panel, except SY1	8	1	----	----	2099 926
15-03-18	ORNAMENT, w/MEDALLION, Hood Top					
	NOTE: See Exterior Moulding Illustrations in Front of Group 23 Body.					
15-03-42	PLATE, Ornament, Rear, SP1, SP2		1	----	E2417 240	
15-03-60	SILENCER	6	1	2259 105		
	SP1, SP2		1	----	2276 870	
	SD1, SD2		1	----	2241 877	
	SD3	8	1	----	*2241 165	
	SC1, SC2, SC3	8	1	----	----	*2241 167
	SY1	8	1	----	----	*2276 955
	CLIP	8	★	6000 932	6000 932	6000 932

15-06-0 HOOD NAME PLATE, MEDALLIONS AND LETTERS

NOTE: See Exterior Moulding Illustrations in Front of Group 23 Body.

15-09-0 HOOD BUMPER						
15-09-4	BUMPER, Fender to Hood	6	2	2082 688		
	Fender to Hood (also specify 2-6023 541 Screw)		2	2276 804	2276 804	
	Fender to Hood, w/o Stud, Front		2	----	2276 603	
	Fender to Hood, w/o Stud, Rear		2	----	2276 749	
	Fender to Hood, w/o Stud, SD3	8	4	----	1904 825	
	Radiator Cross Bar to Hood, SD3	8	2	----	6010 155	
	Fender to Hood, except SY1	8	4	----	----	2276 865
	Fender to Hood, Front, SY1	8	4	----	----	1904 197
	Fender to Hood, Side, SY1	8	6	----	----	1904 198
	Hood to Radiator Cross Bar, SD1, SD2, SD3		2	----	6010 155	6010 155
15-09-22	WASHER, Radiator Yoke to Hood Bumper	6	2	1903 513	6022 189	
	Radiator Cross Bar to Hood	8	2	----	6022 188	6022 188
15-11-0 HOOD LOCK						
15-11-3	LOCK, Upper Half, SV1	6	1	2242 181		
	Upper Half, SL1	6	1	2195 498		
	Upper Half, SP1, SP2		1	----	2099 402	
	Upper Half, SD1, SD2		1	----	2099 513	
	Upper Lock, except SY1	8	1	----	----	1904 643
	Upper Lock, SY1	8	1	----	----	1904 143
	Upper Half, SD3	8	1	----	1904 691	
	Lower Half, SD3	8	1	----	1904 598	
	Lower Lock, except SY1	8	1	----	----	1904 415
	Lower Lock, SY1	8	1	----	----	1904 175
	NUT, Upper Lock	8	4	----	----	6000 123

★ Indicates use as required.

Numerals in parentheses () refer to notes.

Printed in U.S.A.

E Indicates parts not listed in any previous parts book.

Prices and specifications subject to change without notice.

* Indicates change or addition.

1962 PASSENGER CAR PARTS CATALOG

CODE	PART NAME AND DESCRIPTION	C Y L.	P E R C A R	VALIANT LANCER	PLYMOUTH DODGE	CHRYSLER IMPERIAL
15-11-0 HOOD LOCK - Cont'd						
15-11-3	SCREW, w/WASHER, Upper Lock	6	3	6022 525		
	Lower Lock	6	2	6022 525		
	Upper Lock		★	-----	6022 530	
	Lower Lock		★	-----	6022 506	
	Upper Lock	8	★	-----	-----	6022 506
	Lower Lock	8	★	-----	-----	6022 506
15-11-7	BRACE, Lower Lock, except SY1	8	1	-----	-----	1904 413
	Lock Support to Dust Shield, SY1	8	1	-----	-----	2099 801
15-11-9	NUT, w/WASHER, Upper Lock, SV1	6	3	2076 232		
15-11-12	PLATE, Lower Lock, SV1	6	1	2242 216		
15-11-16	SPRING, Lower Lock Locking Lever, SD3	8	1	-----	1904 104	
15-11-38	SPRING, Upper Lock Safety Catch		1	-----	2099 407	
	Upper Lock Locking Bolt		1	-----	2099 407	
	Upper Lock Safety Catch, SD3		1	-----	1541 977	
15-11-46	SUPPORT, Lock to Front Crossmember, SV1	6	1	*2082 086		
	Lower Lock Plate to Yoke, SD3, SC1, SC2	8	1	-----	1904 908	1904 908
	Lower Lock Plate to Yoke, SC3	8	1	-----	-----	1863 719
	Lower Lock Plate to Yoke, SY1	8	1	-----	-----	1904 173
	SCREW, Support to Yoke, Upper, SD3	8	4	-----	6022 506	6022 506
15-11-58	PLATE, Lower Lock Base, SL1	6	1	2195 520		
	Except SY1	8	1	-----	-----	1904 407
15-13-0 HOOD LOCK STRIKER						
15-13-2	STRIKER, Lower Lock		1	2195 497	2428 041	
	Upper Lock, SD3	8	1	-----	1863 331	1863 331
15-13-5	SPRING, Upper Lock Striker, SD3, SC1, SC2, SC3	8	1	-----	1903 285	1903 285
	Upper Lock Striker, SY1	8	1	-----	-----	1373 263
	Striker Bolt, SY1	8	1	-----	-----	1904 896
15-13-6	RETAINER, Upper Lock Striker Spring, SD3	8	1	-----	1696 605	1696 605
15-14-0 HOOD LOCK CONTROL						
15-14-1	CONTROL, on Instrument Panel, SY1	8	1	-----	-----	2217 195
	Hog Ring	8	2	-----	-----	6008 076
	CLIP	8	1	-----	-----	6015 143
15-14-12	STOP, Control Cable, SY1	8	1	-----	-----	932 143
15-14-13	SCREW, Cable Stop, SY1	8	1	-----	-----	988 098
15-14-20	GROMMET, Control Cable, SY1	8	1	-----	-----	2161 290
15-14-21	SLEEVE, Control Cable, SY1	8	1	-----	-----	2097 055
15-19-0 HOOD HINGE						
15-19-2	HINGE, Right	6	1	2082 020		
	Left	6	1	2082 021		
	Right		1	-----	2099 384	
	Left		1	-----	2099 385	
	Right, SD3, SC1, SC2	8	1	-----	1903 440	1903 440
	Left, SD3, SC1, SC2	8	1	-----	1903 441	1903 441

★ Indicates use as required.

⊠ Indicates parts not listed in any previous parts book.

Numerals in parentheses () refer to notes.

Prices and specifications subject to change without notice.

Printed in U.S.A.

March 8, 1963 Supersedes May 1, 1962.

* Indicates change or addition.

CODE	PART NAME AND DESCRIPTION	CYL	PER CAR	VALIANT LANCER	PLYMOUTH DODGE	CHRYSLER IMPERIAL
15-19-O HOOD HINGE - Cont'd						
15-19-2	HINGE - Cont'd					
	Right, SC3	8	1	----	----	1903 028
	Left, SC3	8	1	----	----	1903 029
	Right, SY1	8	1	----	----	1904 160
	Left, SY1	8	1	----	----	1904 161
	SCREW, w/WASHER, Hinge to Side Shield, SP1, SP2	2		----	6022 533	
	Hinge to Hood, SP1, SP2	4		----	6022 533	6022 532
	Hinge to Dash Shield, SP1, SP2	4		----	6022 533	
	Hinge to Side Shield, SD1, SD2	2		----	6022 532	
	Hinge to Hood, SD1, SD2	4		----	6022 532	
	Hinge to Dash, SD1, SD2	4		----	6022 532	
	Hinge to Cowl, except SY1	8	4	----	----	6022 534
	Hinge to Cowl, SY1	8	2	----	----	6022 536
	Hinge to Cowl, Right Side, SY1	8	2	----	----	6022 531
	Hinge to Inner Panel, SY1	8	2	----	----	1903 386
	Hinge to Fender Bracket, SY1	8	2	----	----	6022 237
	Hinge to Support, SY1	8	2	----	----	6022 536
	Hinge to Fender Shield, except SY1	8	4	----	----	6022 031
	Hinge to Flange Reinforcement, SC1, SC2, SC3	8	4	----	----	6022 187
	Hinge to Inner Panel REINFORCEMENT, SY1	8	4	----	----	6022 270
	STUD, Hinge to Cowl, Left Side only, SY1	8	2	----	----	6023 484
	SHIM, Hinge to Panel REINFORCEMENT, SY1	8	2	----	----	6010 031
15-19-8	SPRING, Hinge	6	2	2082 070		
	SD3, SC1, SC2	8	2	----	2099 400 1863 235	1863 235
	SC3	8	2	----	----	1863 708
	SY1	8	2	----	----	1754 236
15-19-40	U-NUT, Hinge to Fender	6	2	2082 878		
15-25-O HOOD MOULDING						
	NOTE: See Exterior Moulding Illustrations in Front of Group 23 Body.					
15-25-6	TAPE, Hood Top Moulding, SY1	8	1	----	----	*2417 202

NOTES

