

GROUP 8 - ELECTRICAL

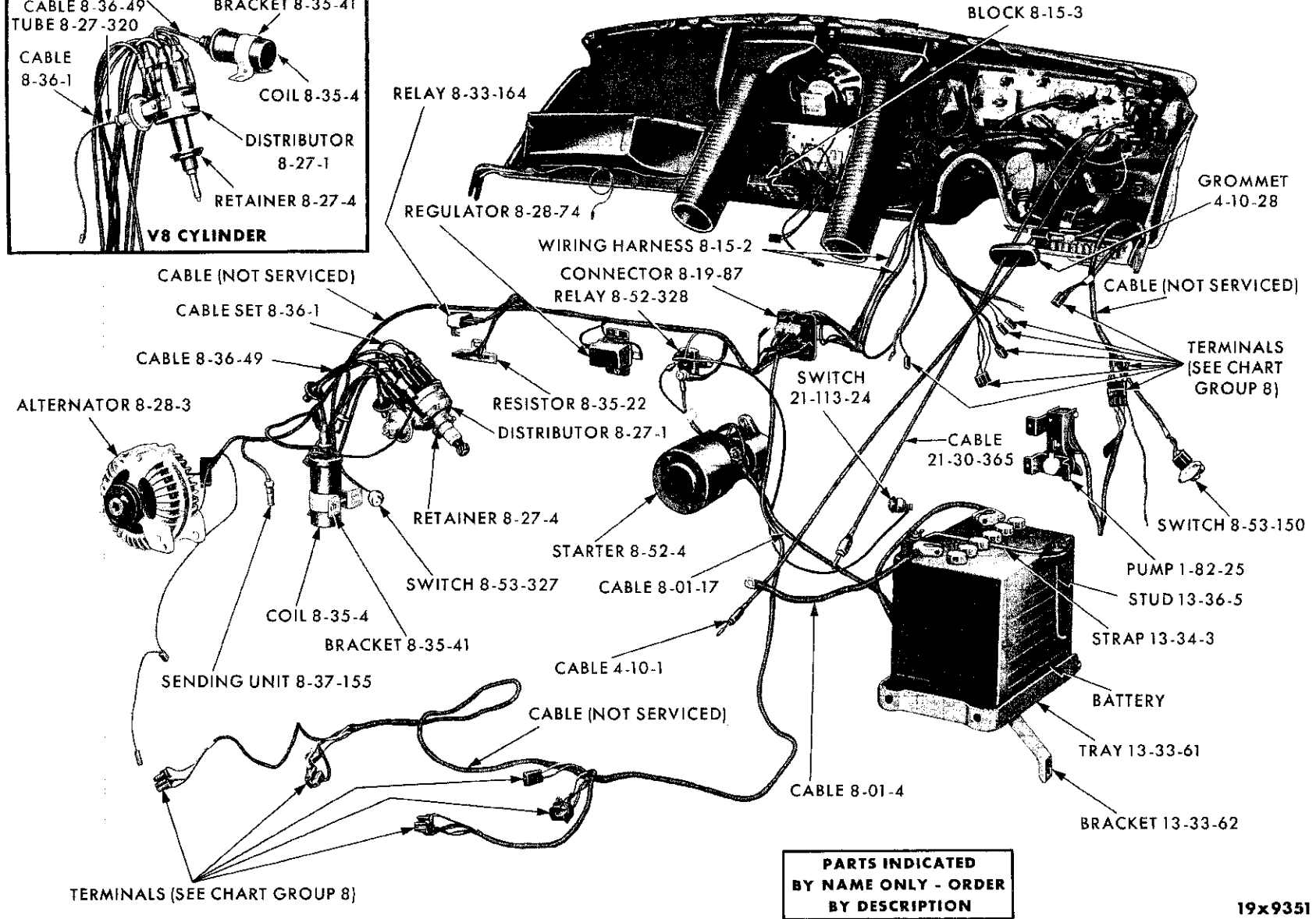
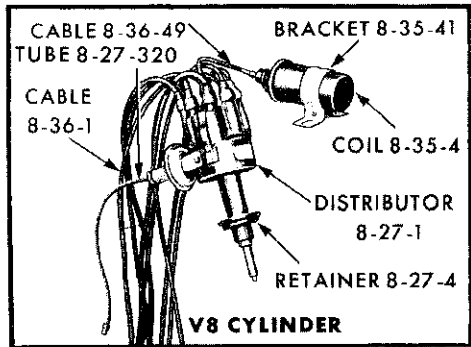

**PARTS INDICATED  
BY NAME ONLY - ORDER  
BY DESCRIPTION**

19x9351

ELECTRICAL SYSTEM

Printed in U.S.A.

Page 8-1

May 1, 1962 Supersedes Nov. 30, 1961.

**PARTS INDICATED  
BY NAME ONLY - ORDER  
BY DESCRIPTION**

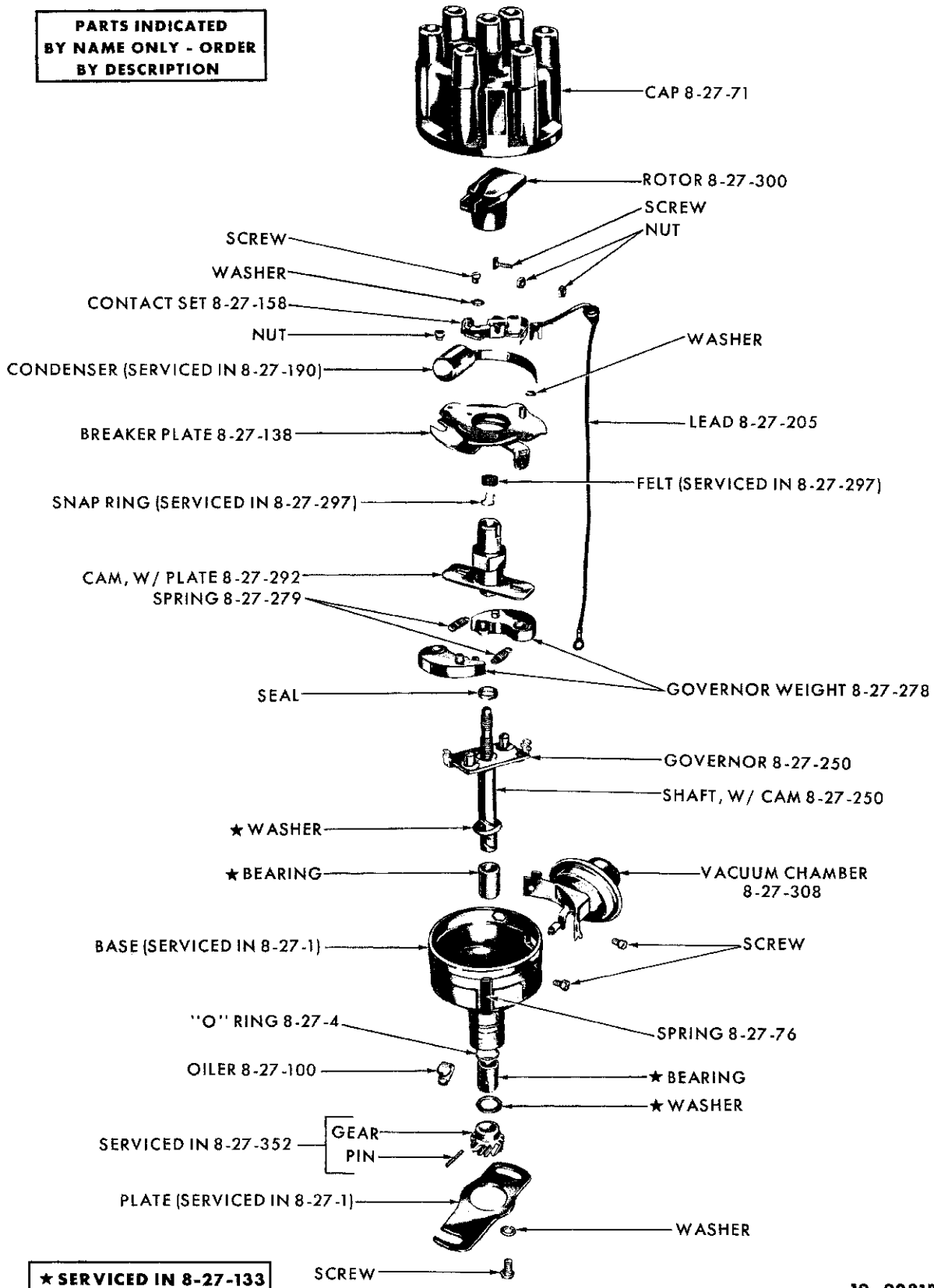

**★ SERVICED IN 8-27-133**

19x9281B

DISTRIBUTOR - 6 CYLINDER

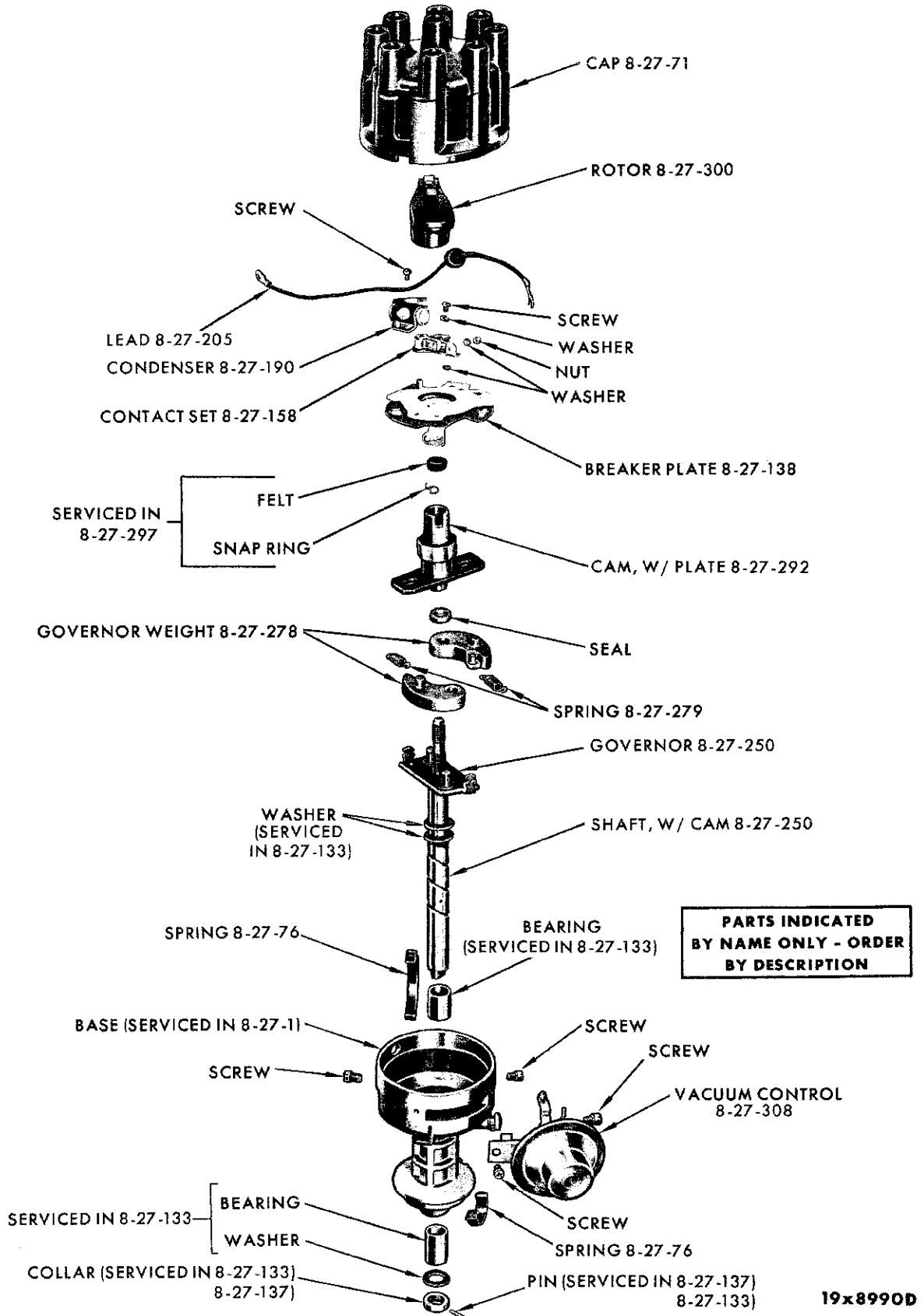

DISTRIBUTOR - V8 CYLINDER



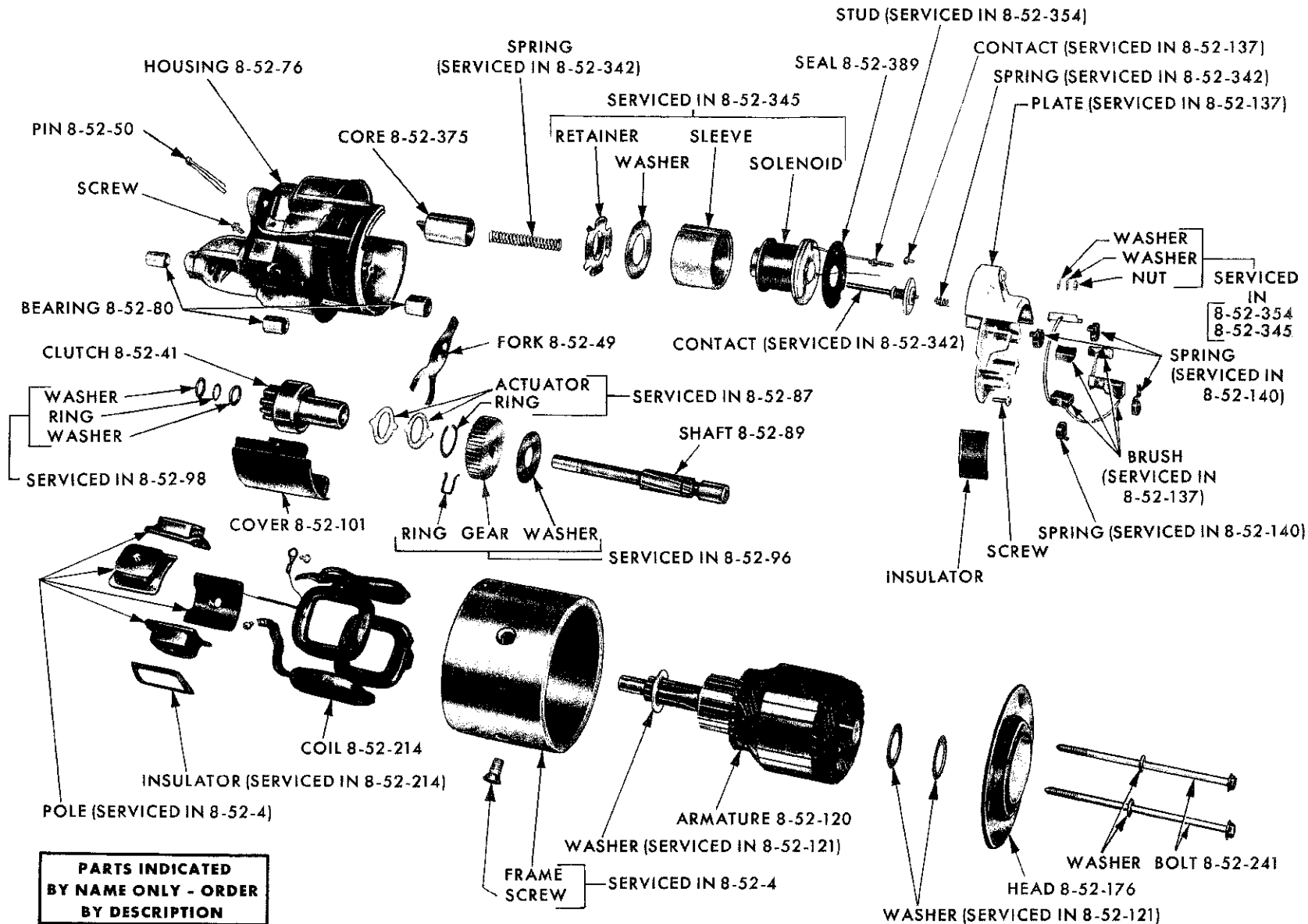

STARTER

19x9186E

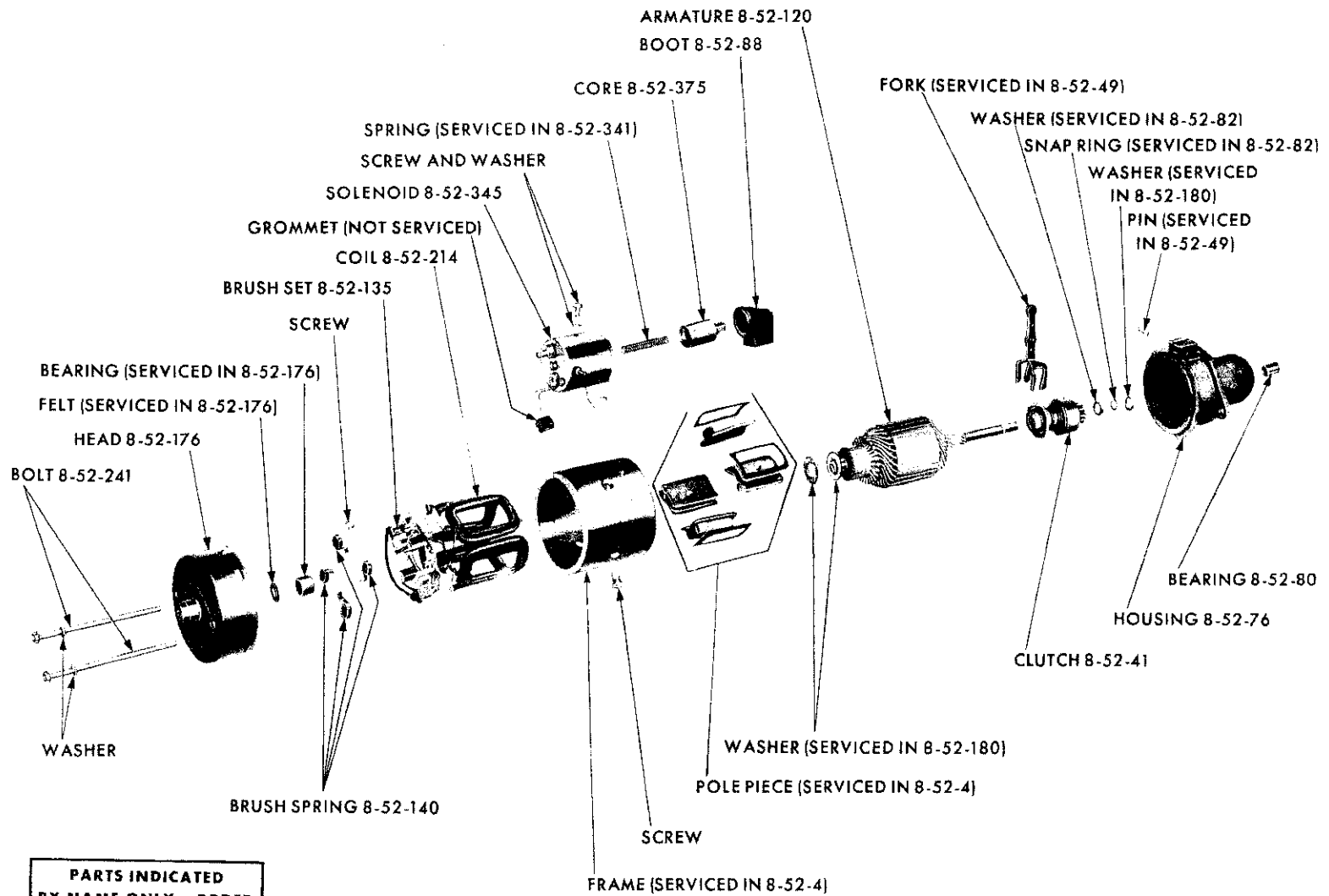

**PARTS INDICATED  
BY NAME ONLY - ORDER  
BY DESCRIPTION**

19x8726C

STARTER - CHRYSLER SC1-2 (STANDARD TRANSMISSION)

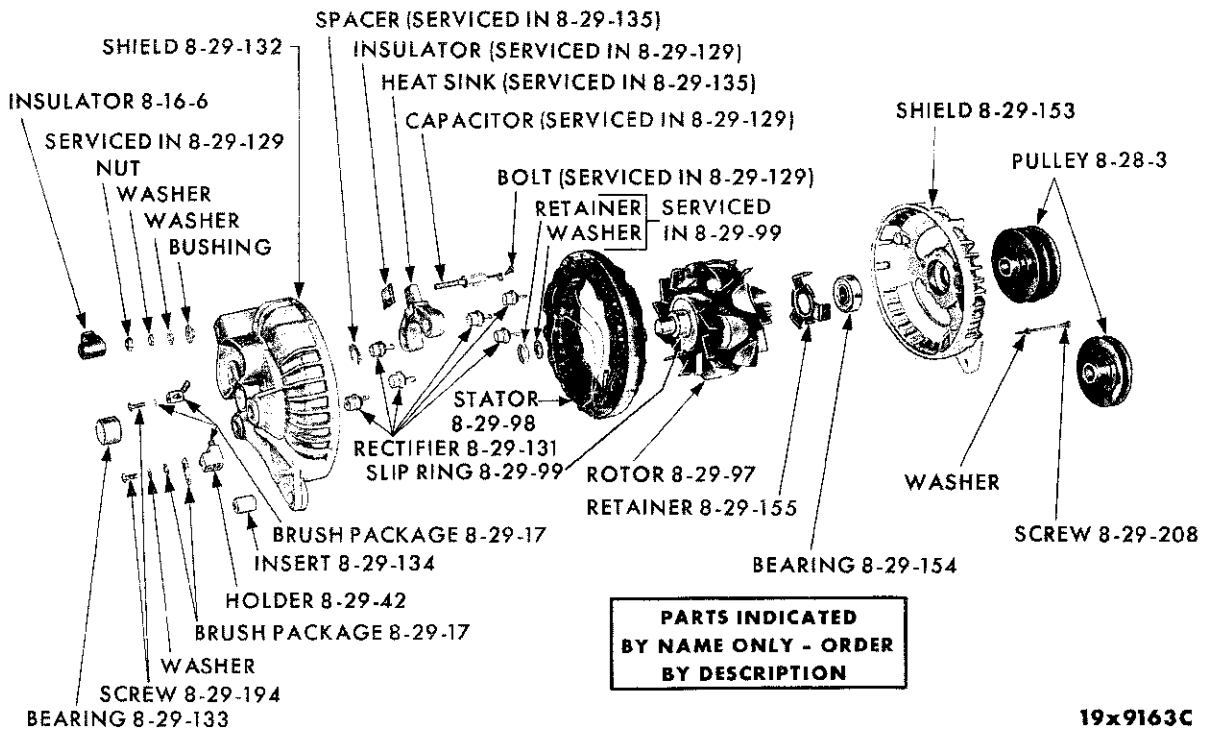

ALTERNATOR

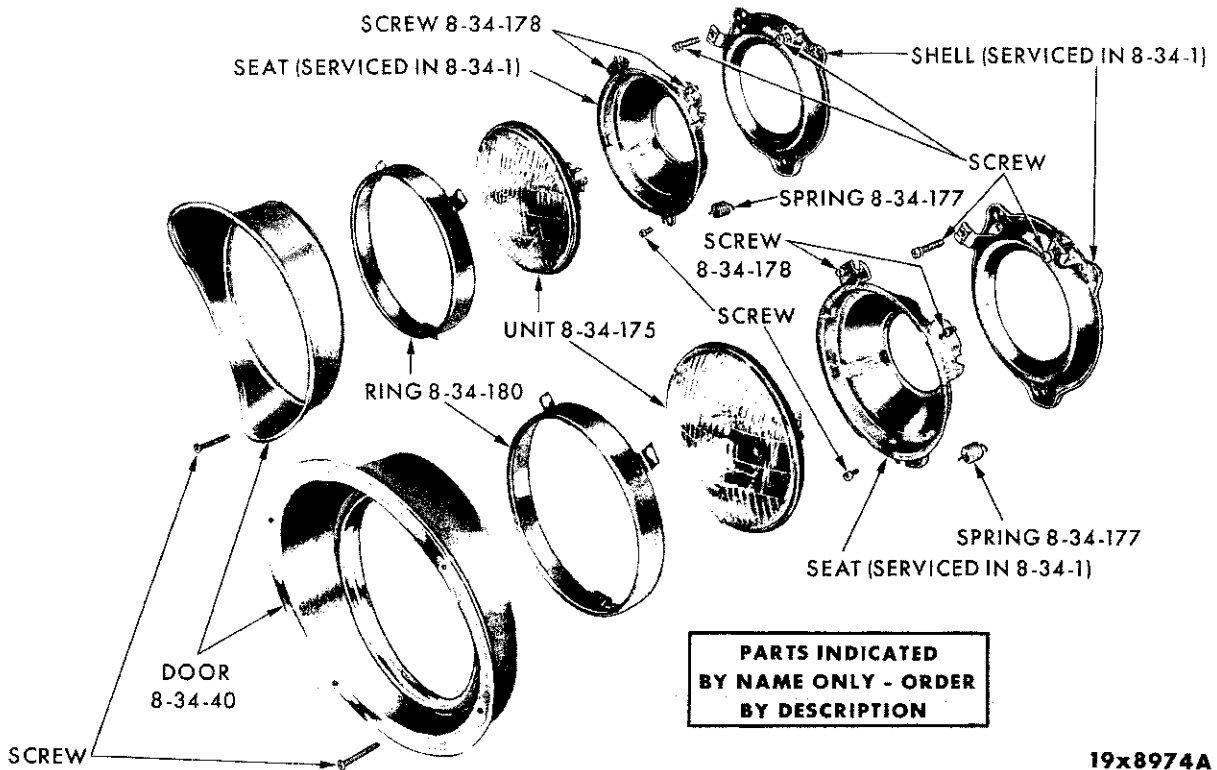

HEADLAMP - PLYMOUTH SP1-2

PARTS INDICATED  
BY NAME ONLY - ORDER  
BY DESCRIPTION

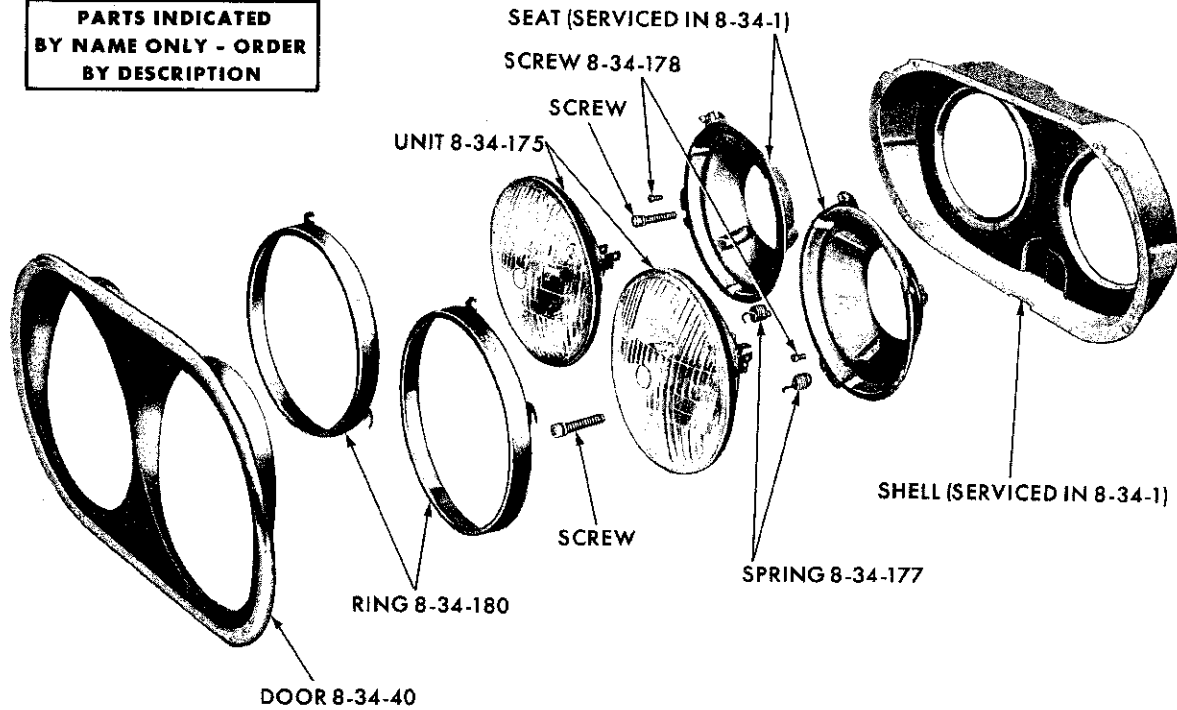

19x8731A

HEADLAMP - VALIANT SV1

PARTS INDICATED  
BY NAME ONLY - ORDER  
BY DESCRIPTION

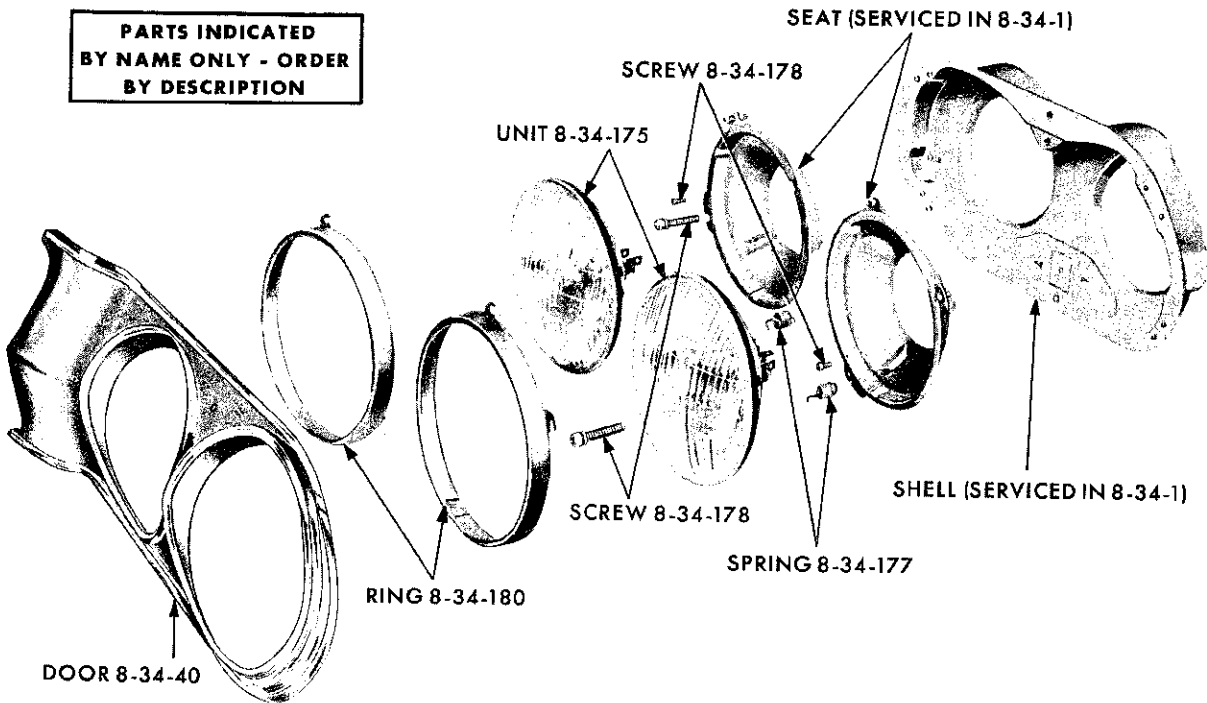

19x8918A

HEADLAMP - LANCER SL1



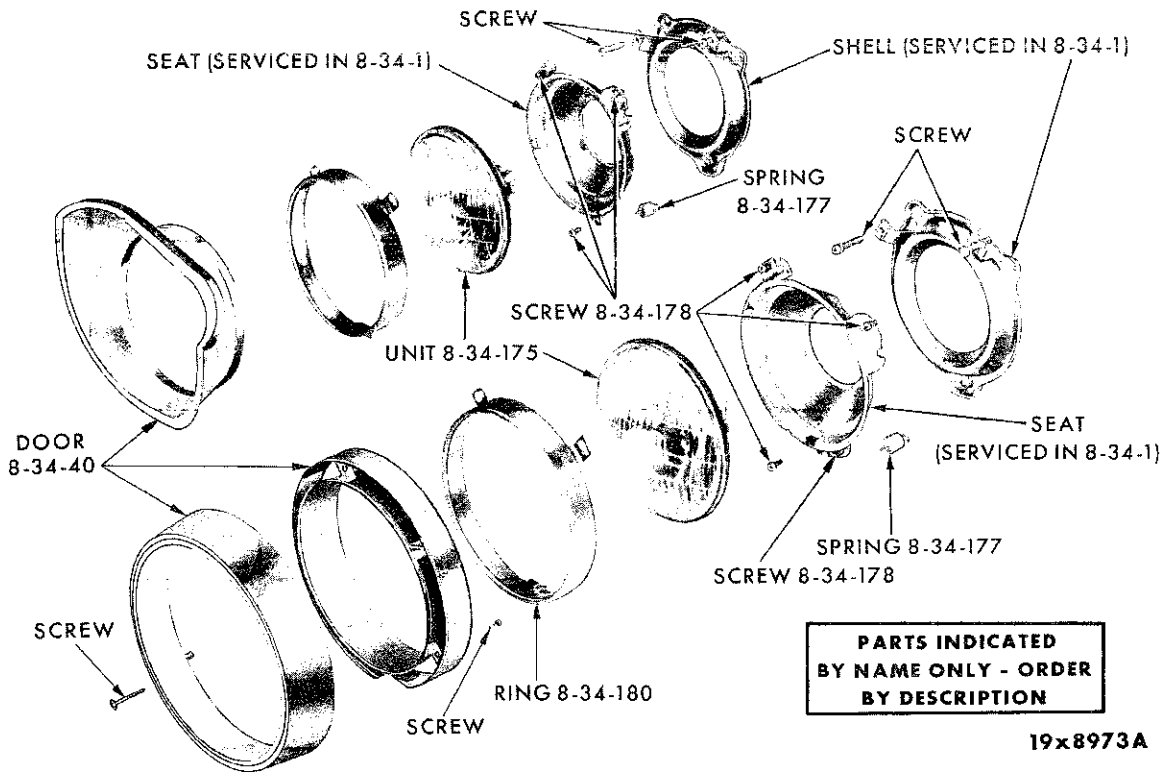

HEADLAMP - DODGE SD1-2

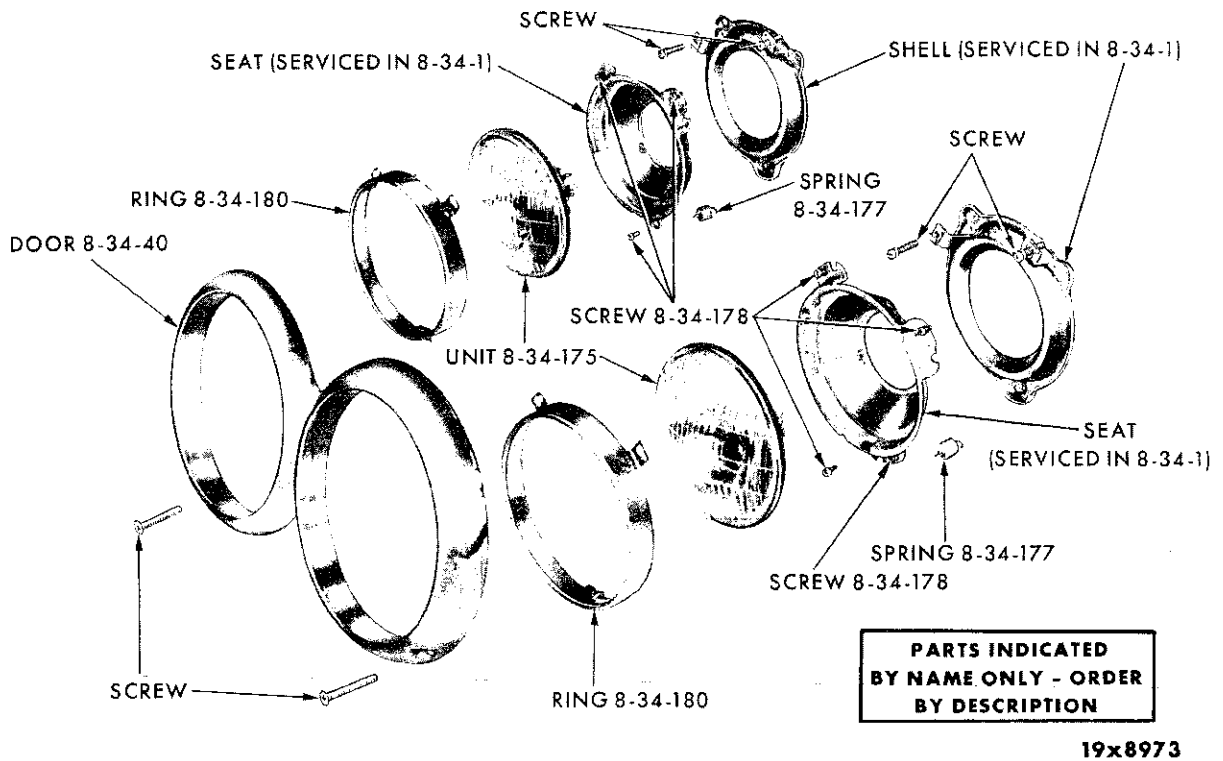

HEADLAMP - DODGE SD3

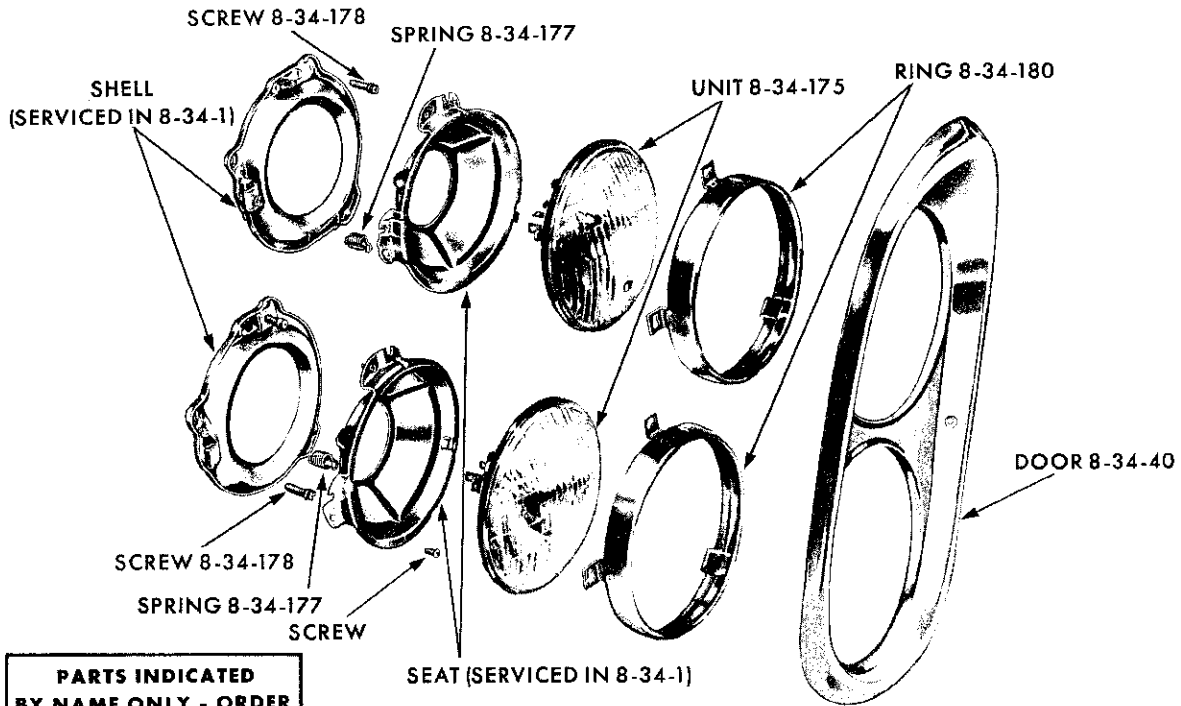

19x8919A

HEADLAMP - CHRYSLER SC1-2-3

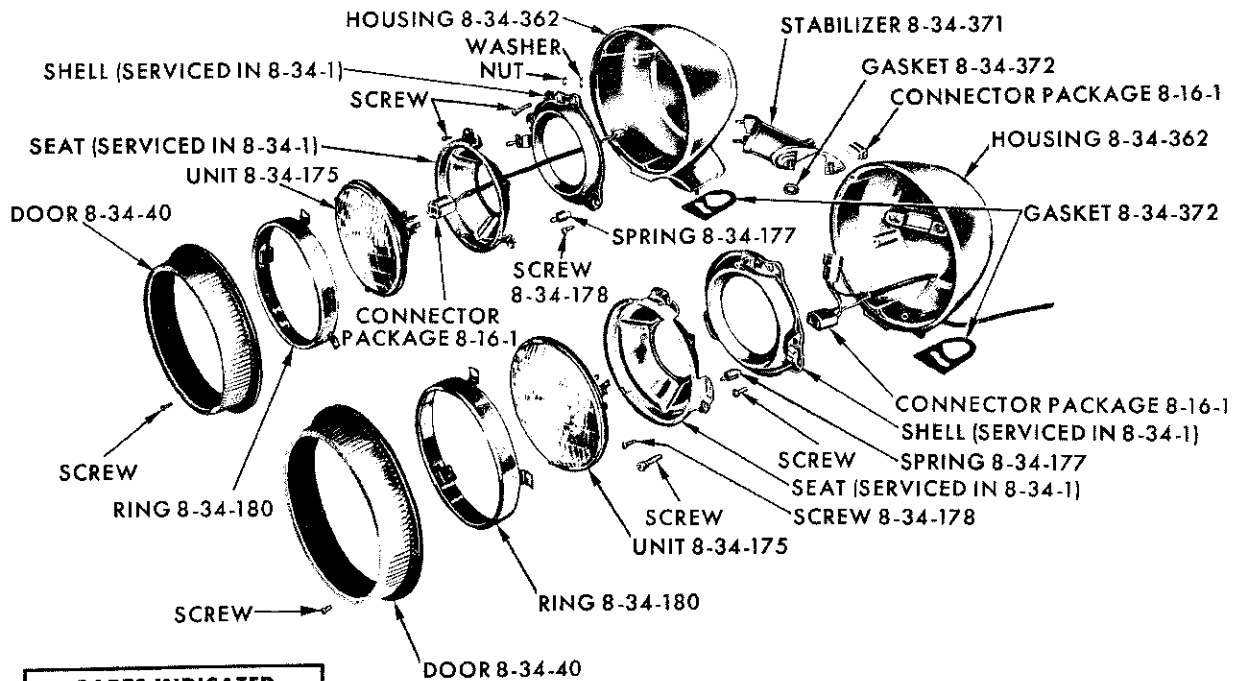

PARTS INDICATED BY NAME ONLY - ORDER BY DESCRIPTION

19x8928A

HEADLAMP - IMPERIAL SY1

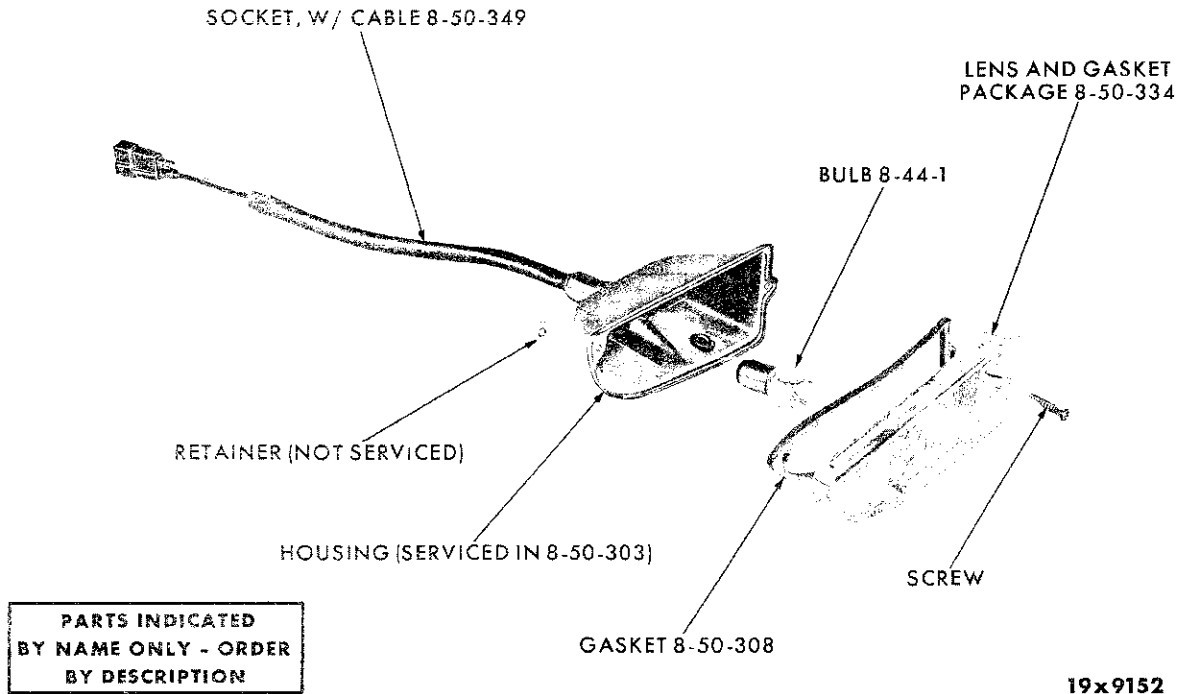

PARKING LAMP - PLYMOUTH SP1-2

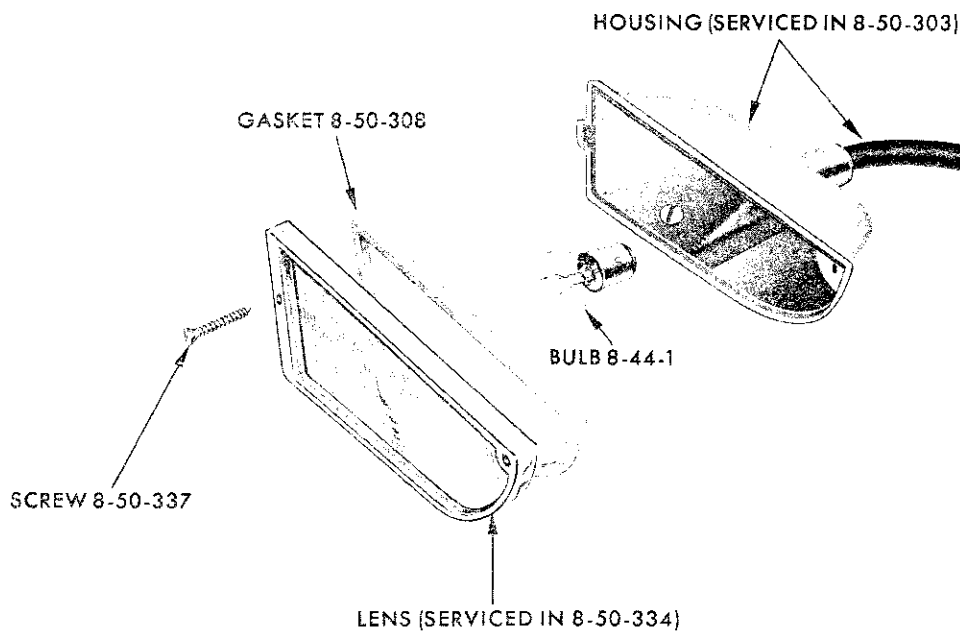

19x8739A

PARKING LAMP - VALIANT SV1

PARTS INDICATED  
BY NAME ONLY - ORDER  
BY DESCRIPTION

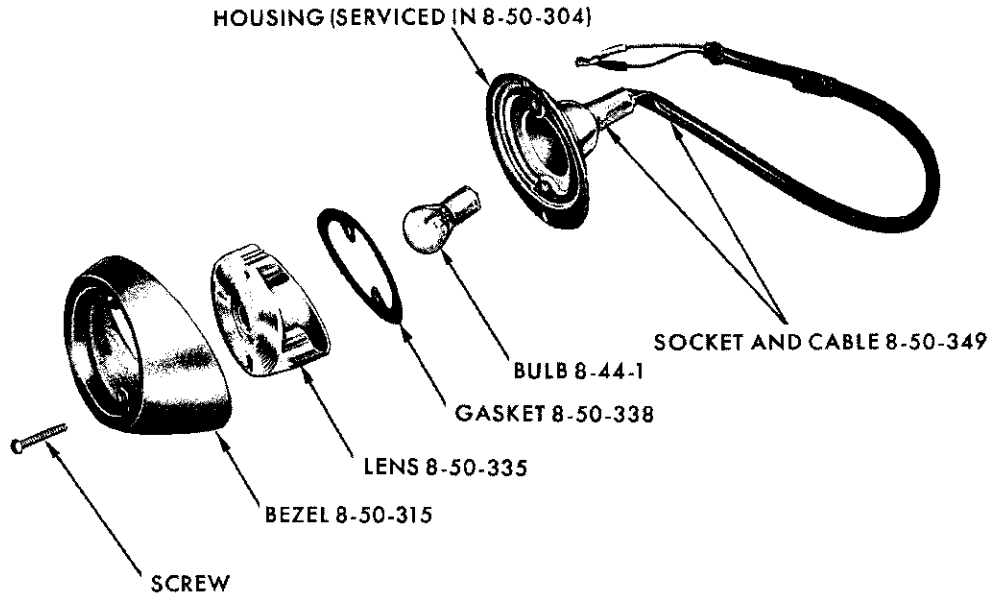

19x8943A

PARKING LAMP - LANCER SL1

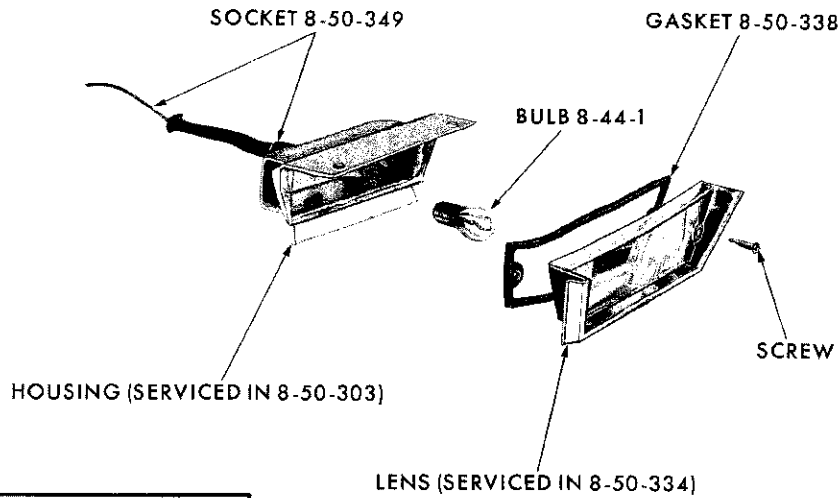

PARTS INDICATED  
BY NAME ONLY - ORDER  
BY DESCRIPTION

19x9187

PARKING LAMP - DODGE SD1-2

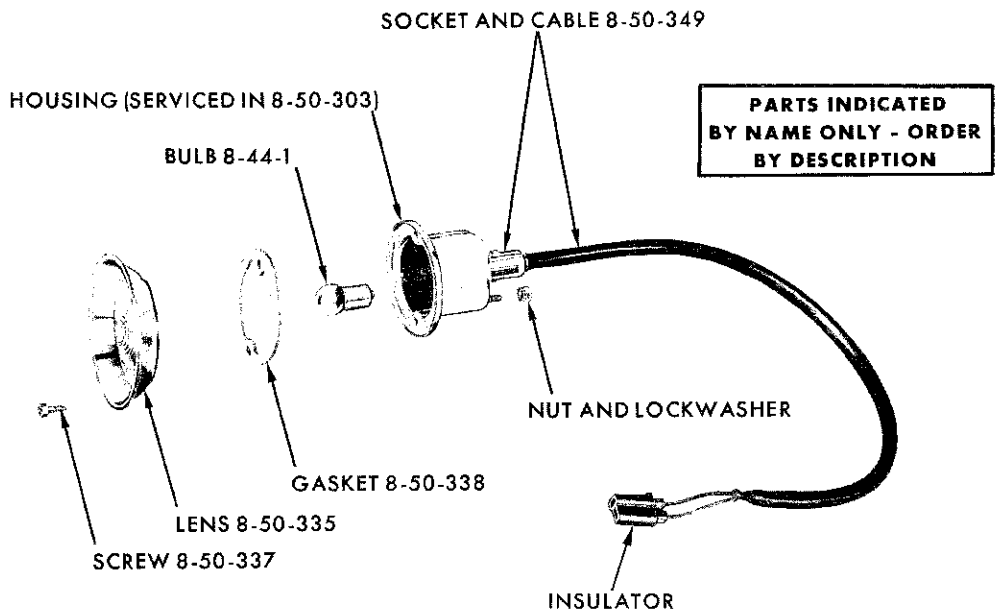

19x8948A

PARKING AND TURN SIGNAL LAMP - DODGE SD3

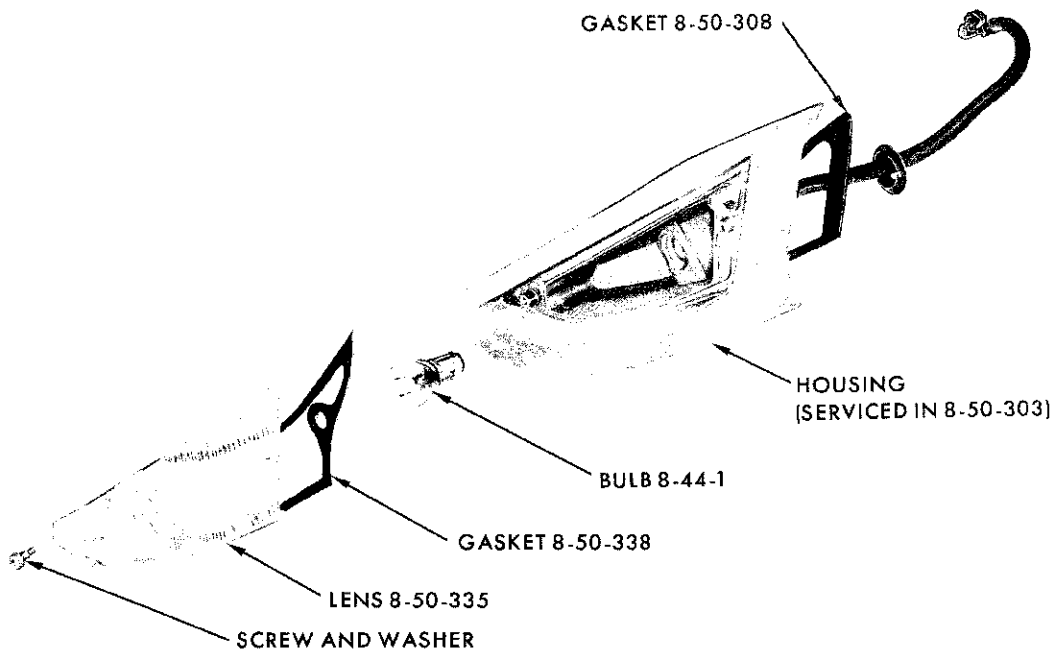

19x8900

PARKING LAMP - CHRYSLER SC1-2-3



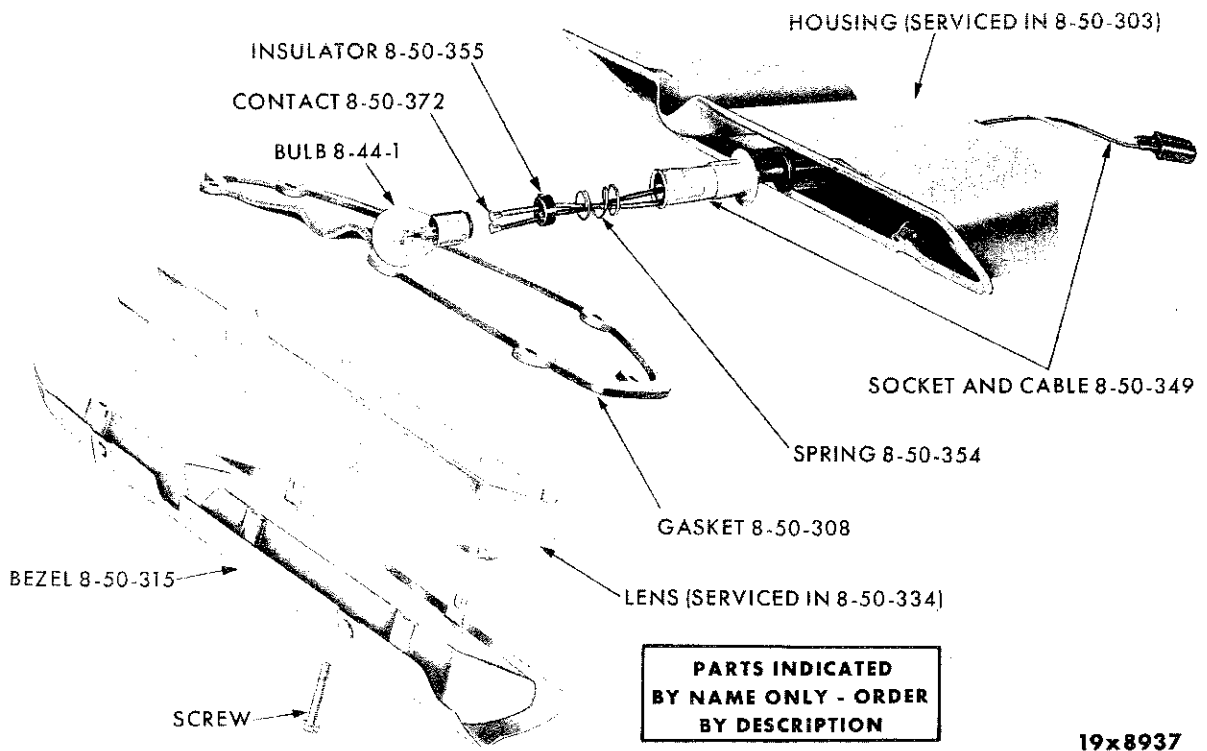

PARKING LAMP - IMPERIAL SY1

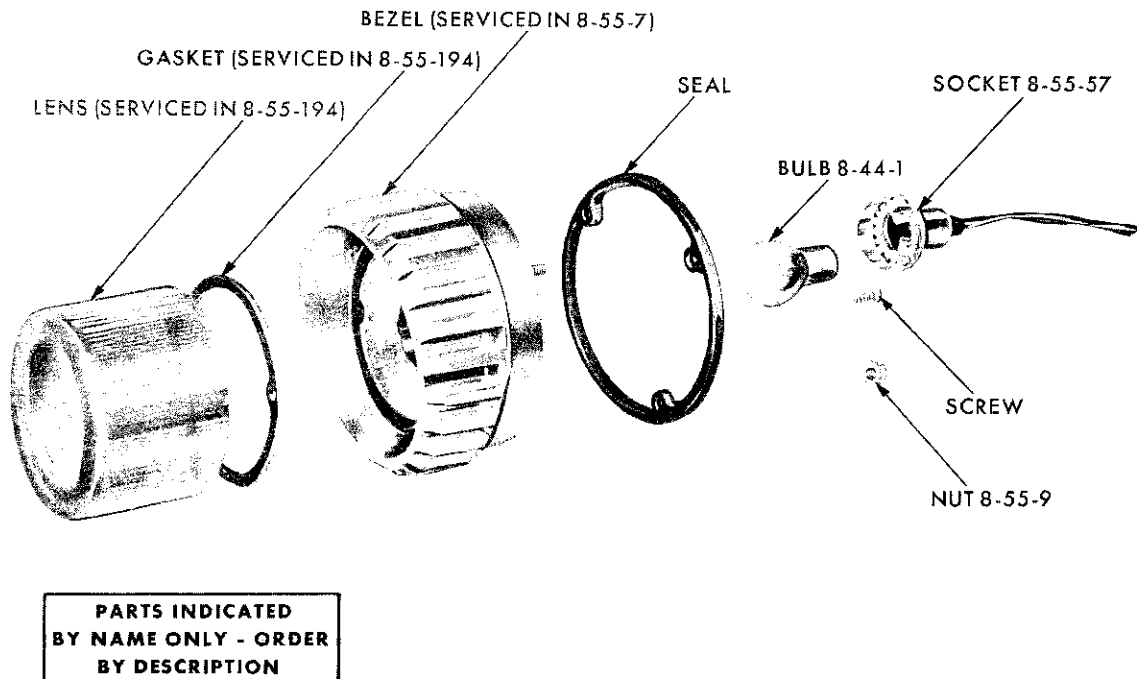

TAIL AND STOP LAMP - PLYMOUTH SP1-2

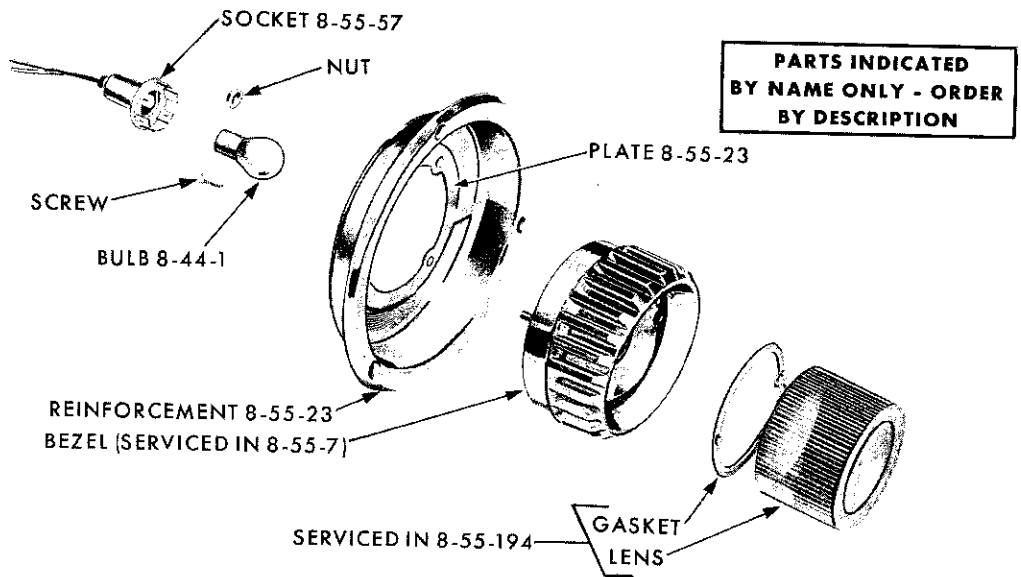

19x9180A

TAIL AND STOP LAMP - PLYMOUTH SP1-2 (SUBURBAN)

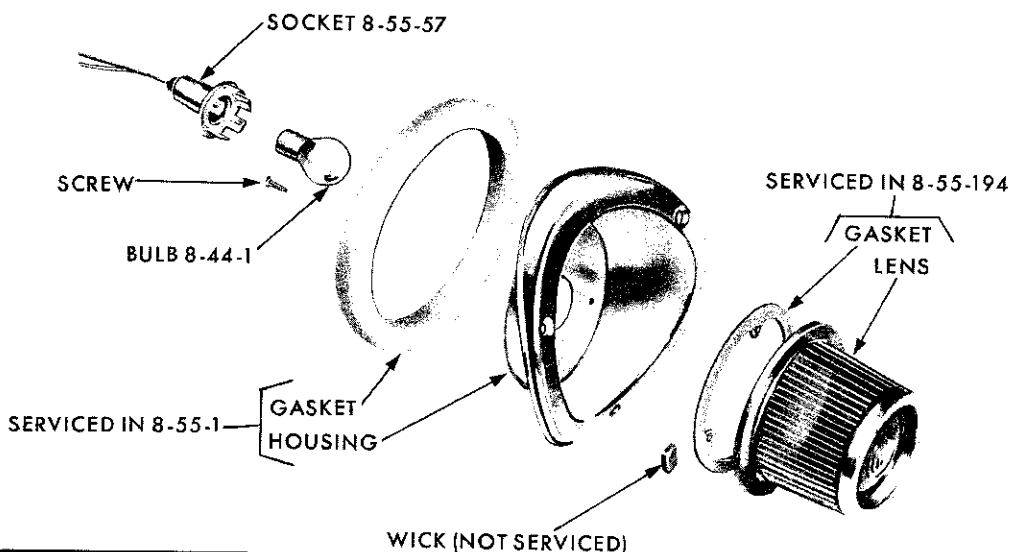

19x9224

TAIL AND STOP LAMP - VALIANT SV1



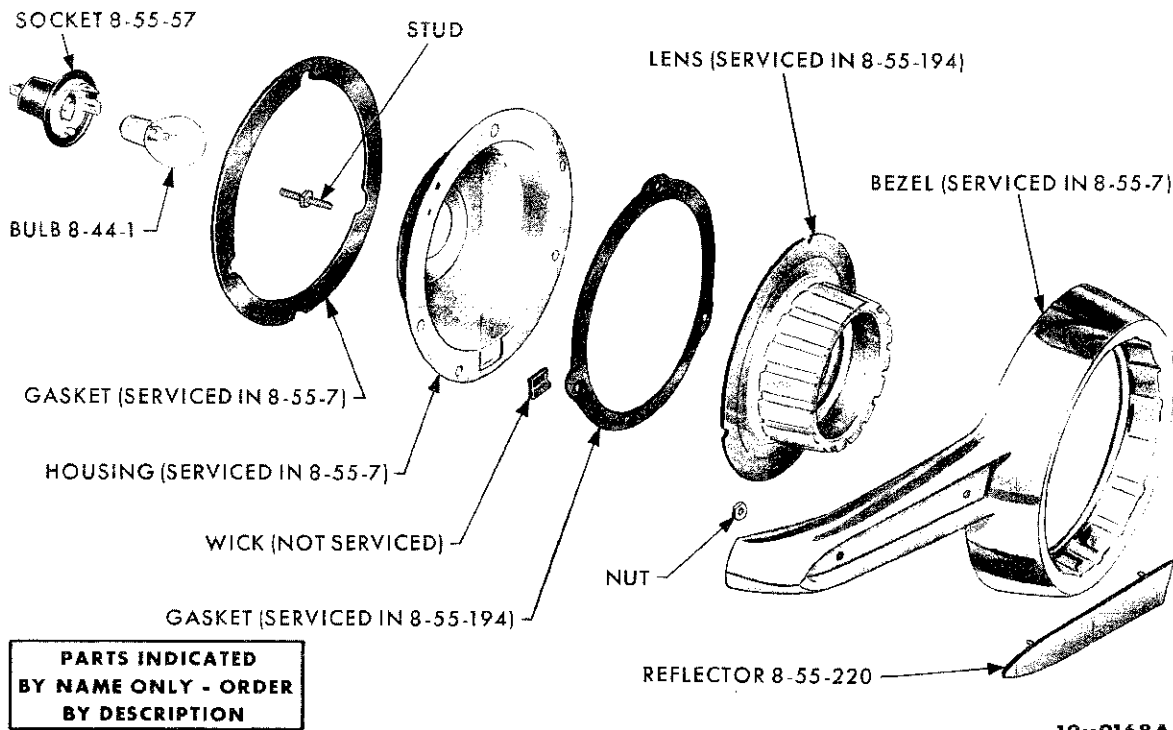

TAIL AND STOP LAMP - LANCER SL1

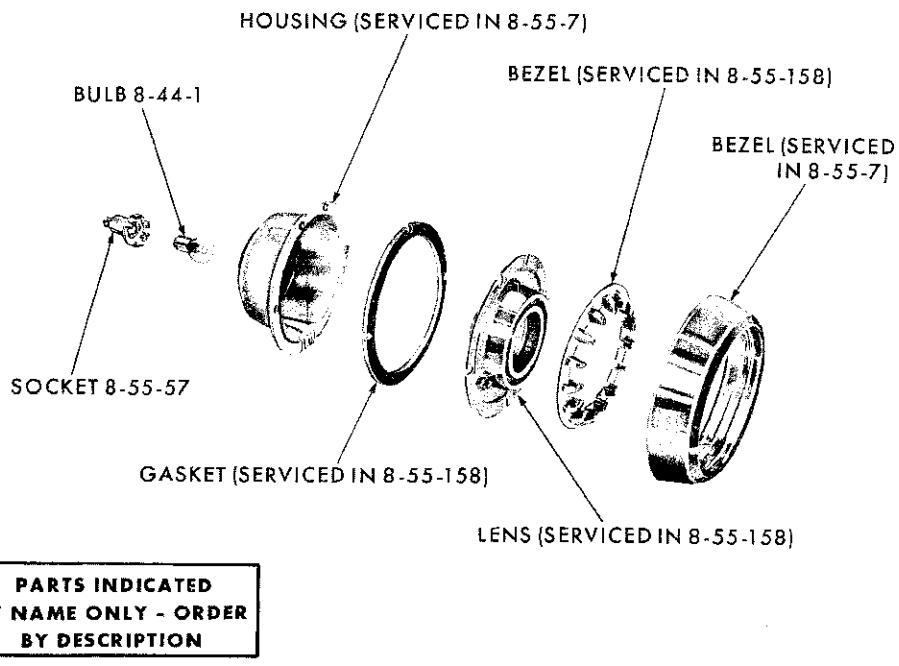

TAIL AND STOP LAMP - DODGE SD1-2 (EXCEPT SUBURBAN)

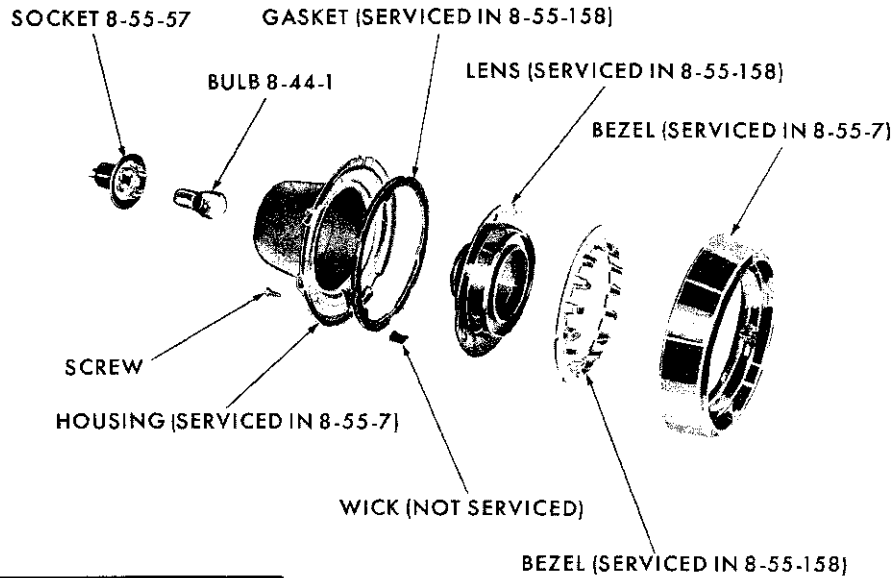

**PARTS INDICATED  
BY NAME ONLY - ORDER  
BY DESCRIPTION**

19x9191

TAIL AND STOP LAMP - DODGE SD1-2 (SUBURBAN)

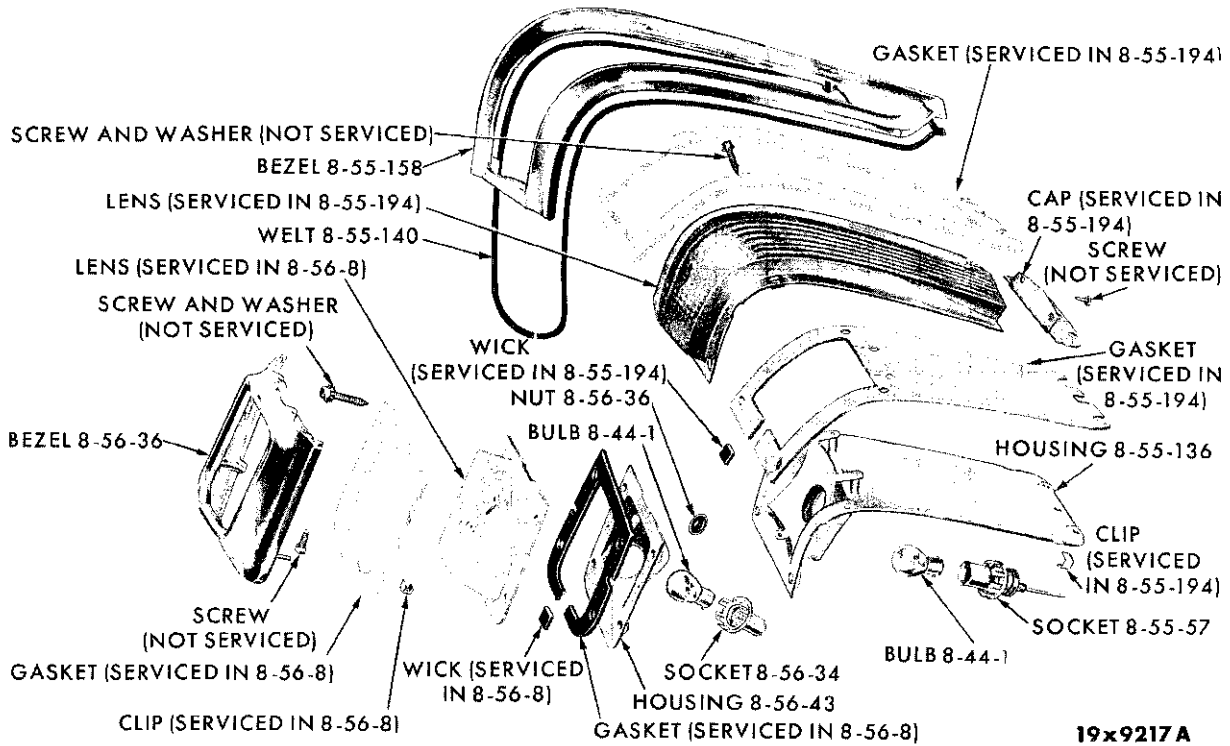

19x9217A

TAIL, STOP AND BACK-UP LAMP - DODGE SD3 AND CHRYSLER SC1-2-3 (EXCEPT SUBURBAN)

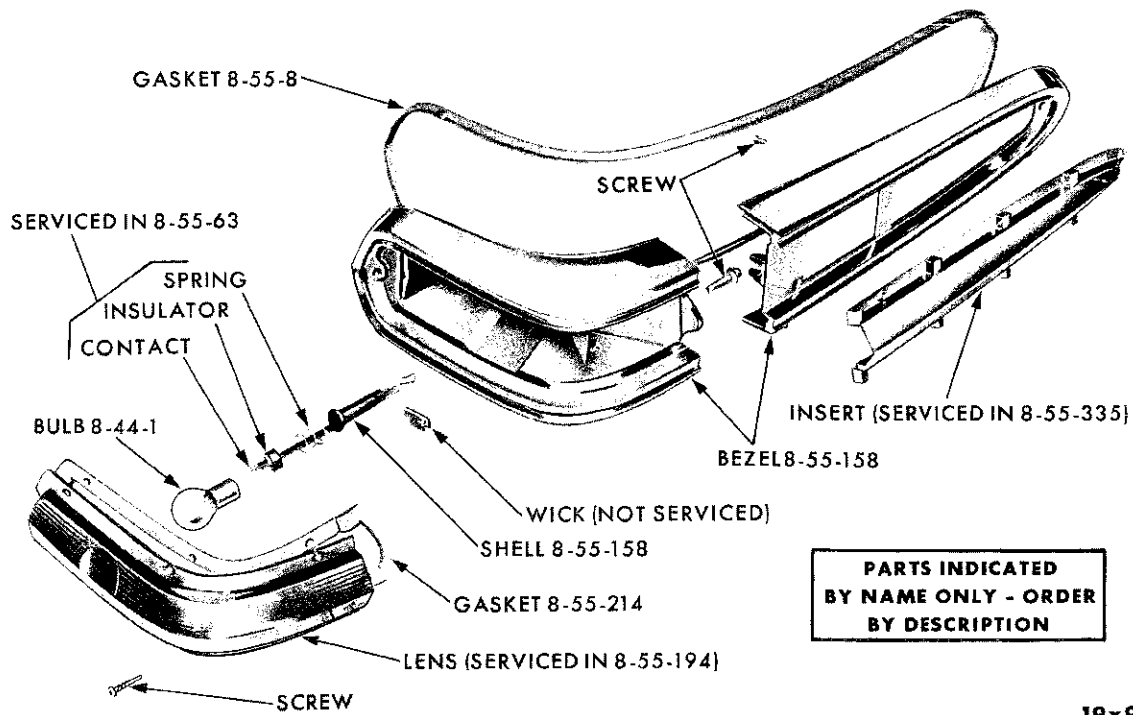

19x9225

TAIL AND STOP LAMP - DODGE SD3 AND CHRYSLER SC1-3 (SUBURBAN)

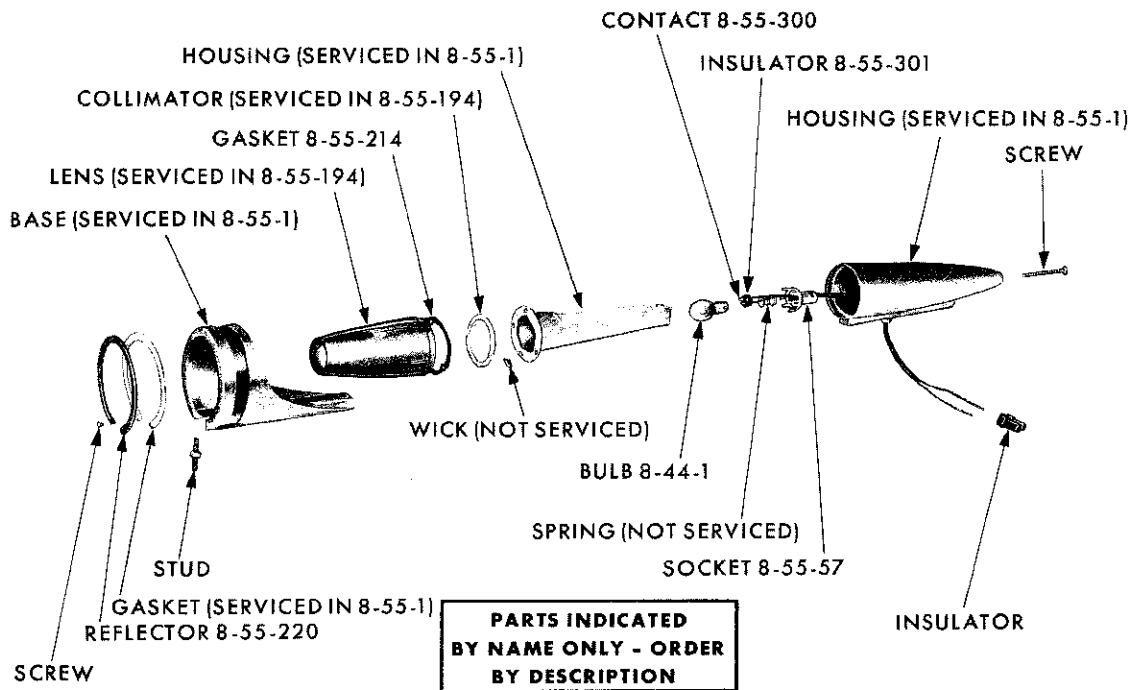

19x9167A

TAIL AND STOP LAMP - IMPERIAL SY1

**PARTS INDICATED  
BY NAME ONLY - ORDER  
BY DESCRIPTION**

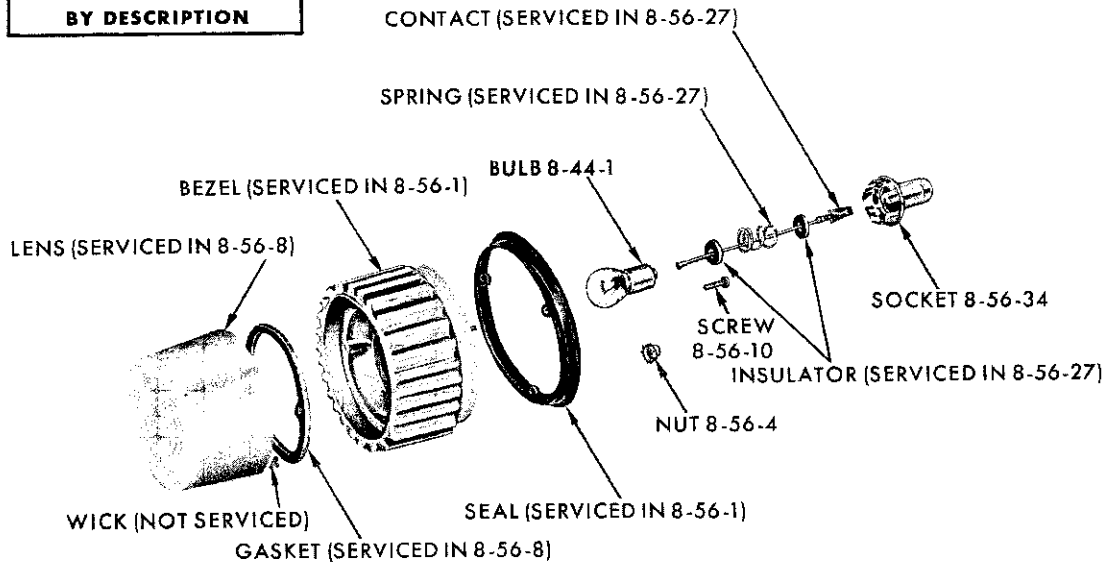

19x8958B

BACK-UP LAMP - PLYMOUTH SP1-2 (EXCEPT SUBURBAN)

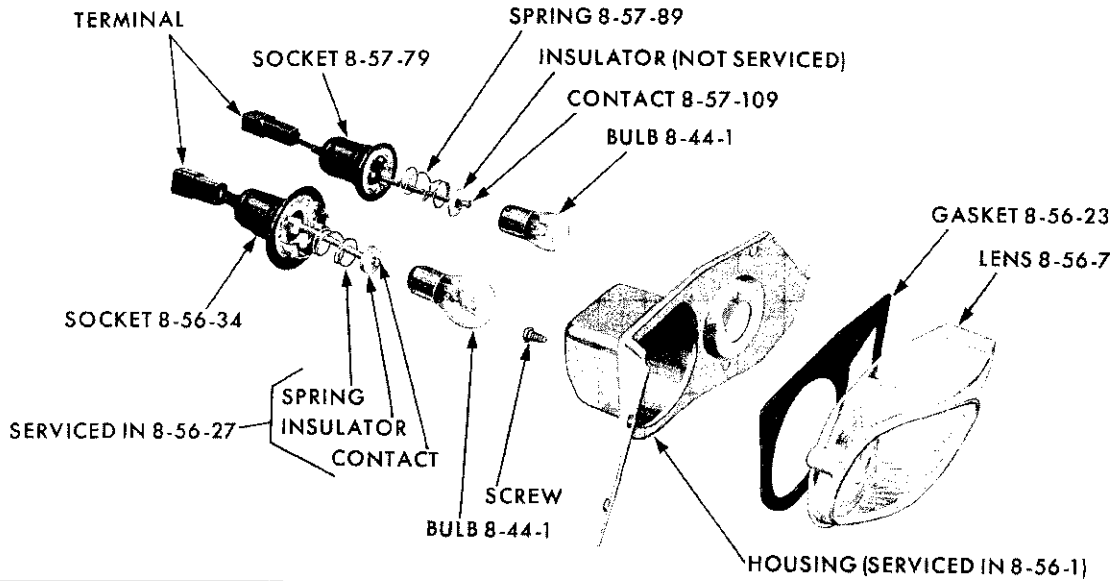

**PARTS INDICATED  
BY NAME ONLY - ORDER  
BY DESCRIPTION**

19x9171

BACK-UP AND LICENSE LAMP - PLYMOUTH SP1-2 (SUBURBAN)

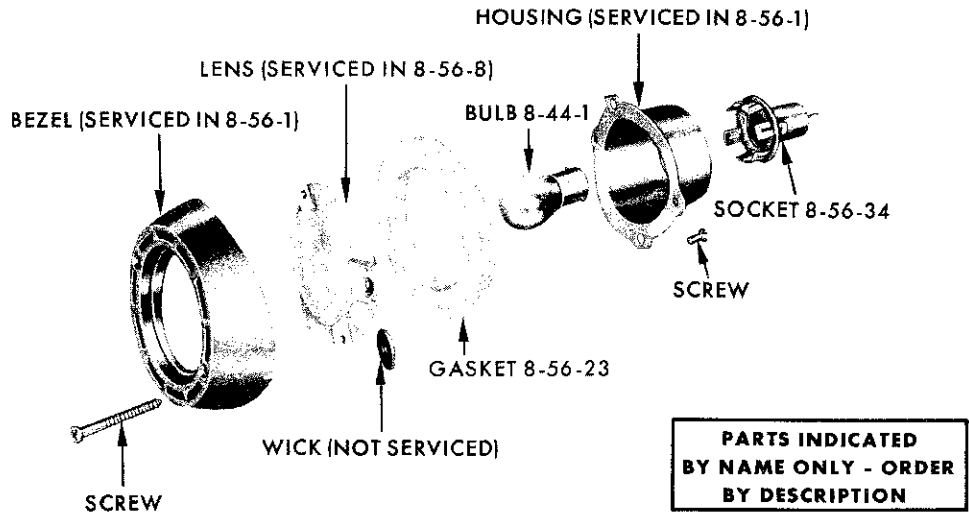

19x8737A

BACK-UP LAMP - VALIANT SV1

PARTS INDICATED BY NAME ONLY - ORDER BY DESCRIPTION

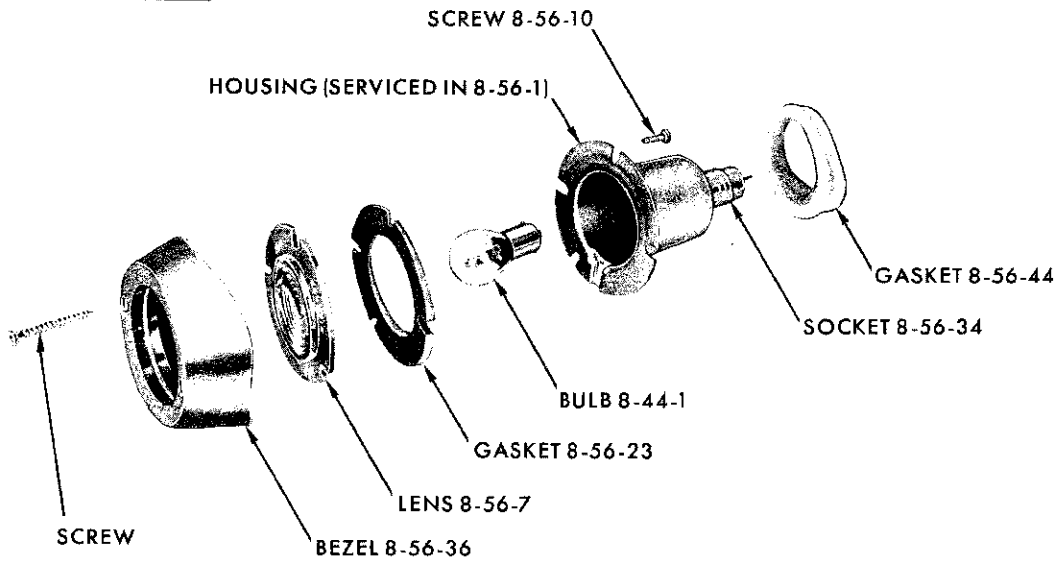

19x8942A

BACK-UP LAMP - LANCER SL1

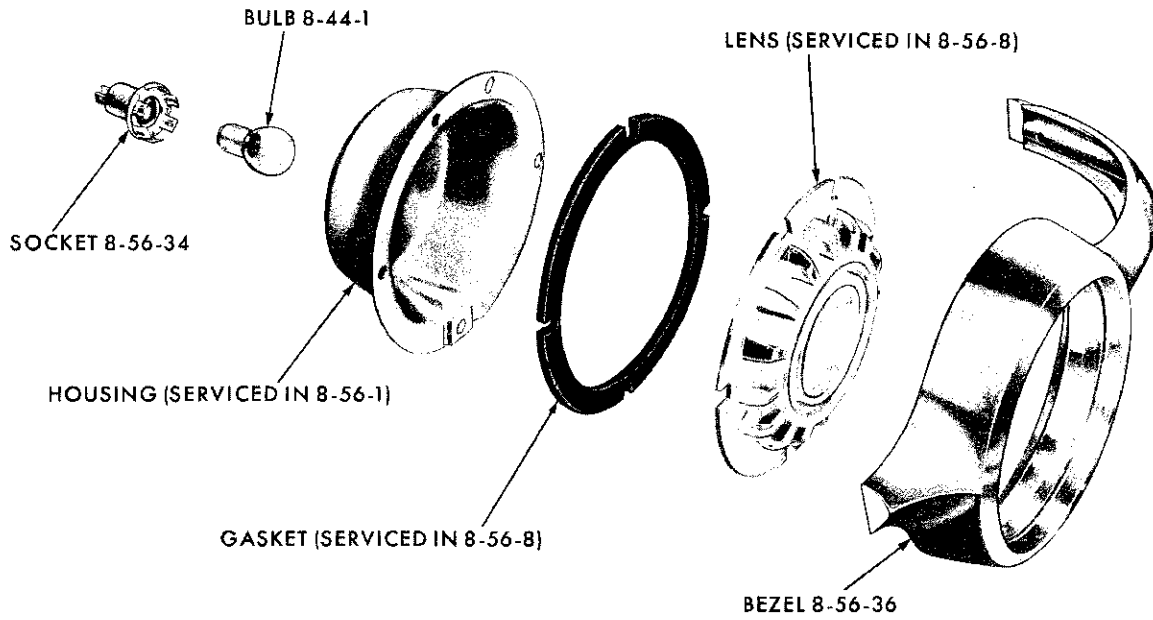

19x9192

BACK-UP LAMP - DODGE SD1-2 (EXCEPT SUBURBAN)

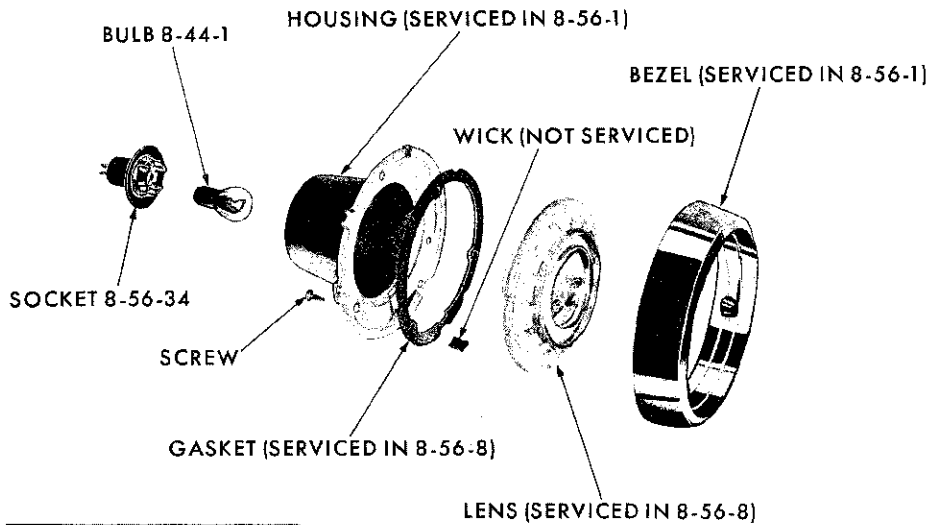

**PARTS INDICATED  
BY NAME ONLY - ORDER  
BY DESCRIPTION**

19x9190

BACK-UP LAMP - DODGE SD1-2 (SUBURBAN)

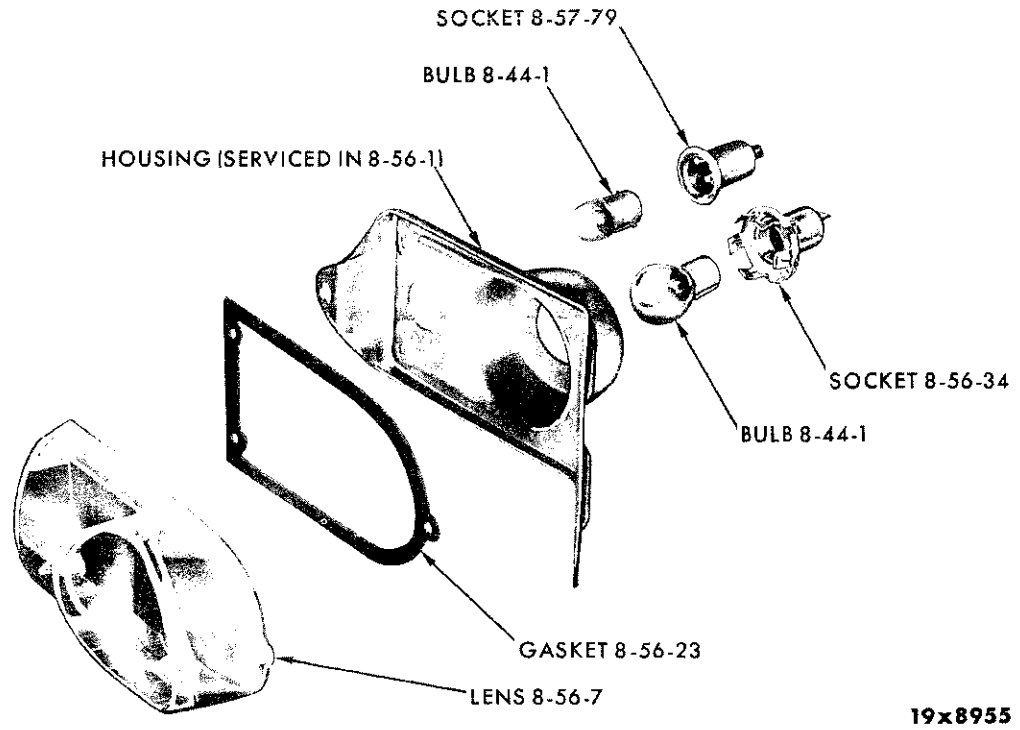

BACK-UP AND LICENSE LAMP - CHRYSLER SC1-2-3 (SUBURBAN)

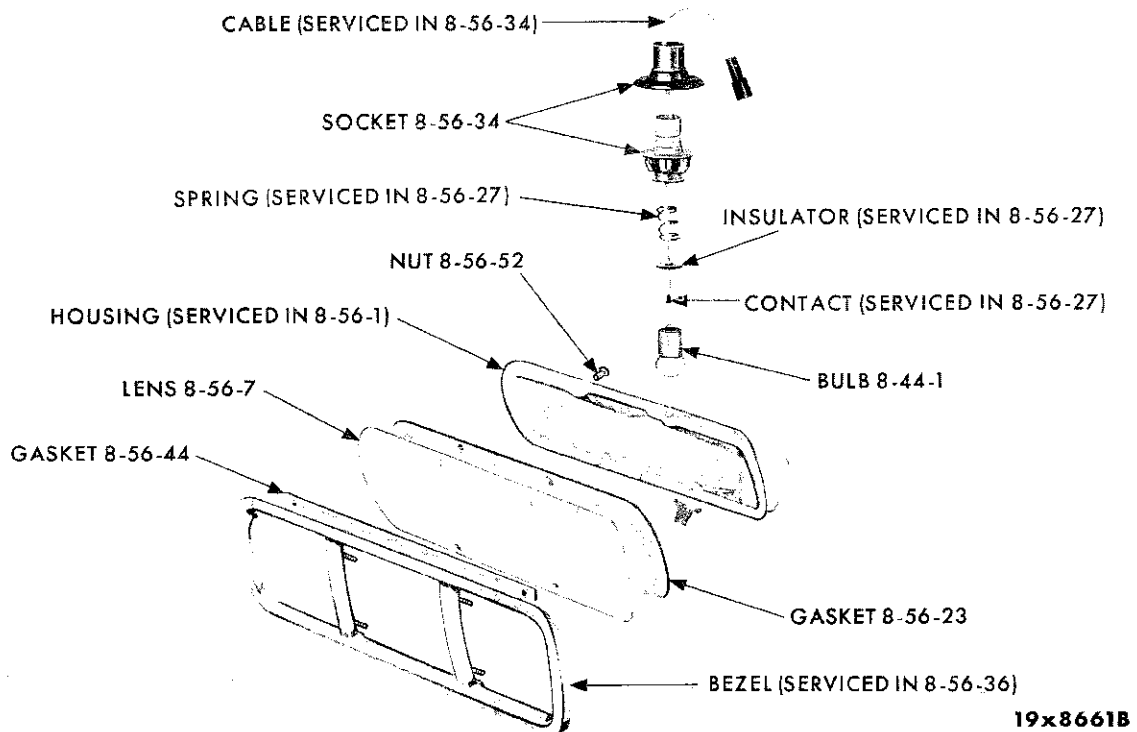

BACK-UP LAMP - IMPERIAL SY1

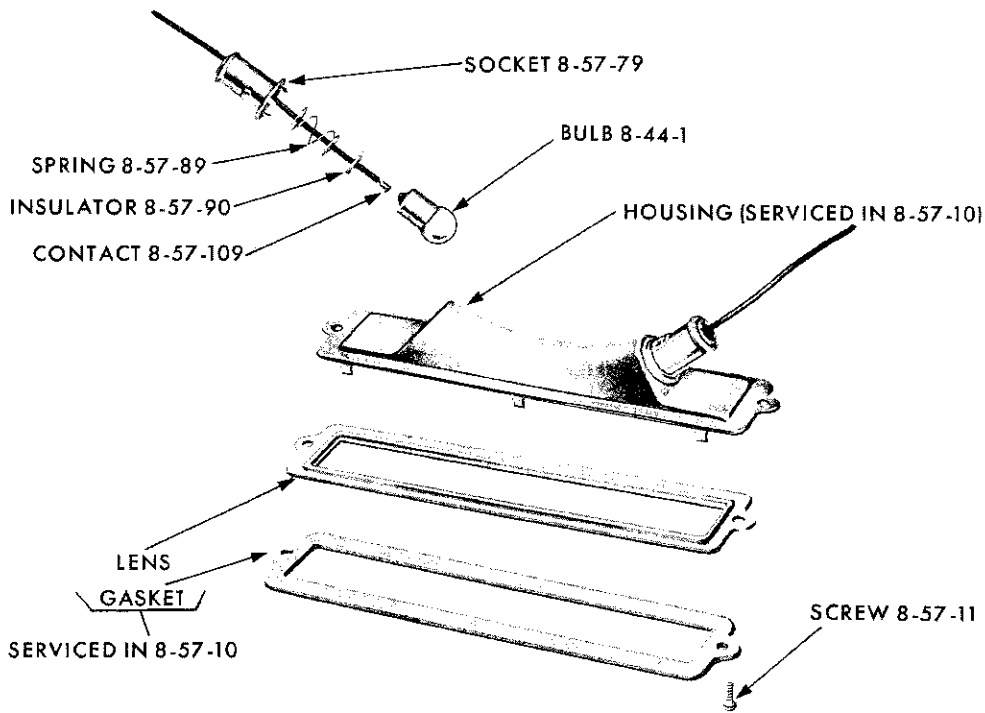

19x9227

LICENSE LAMP - PLYMOUTH SP1-2 (EXCEPT SUBURBAN)

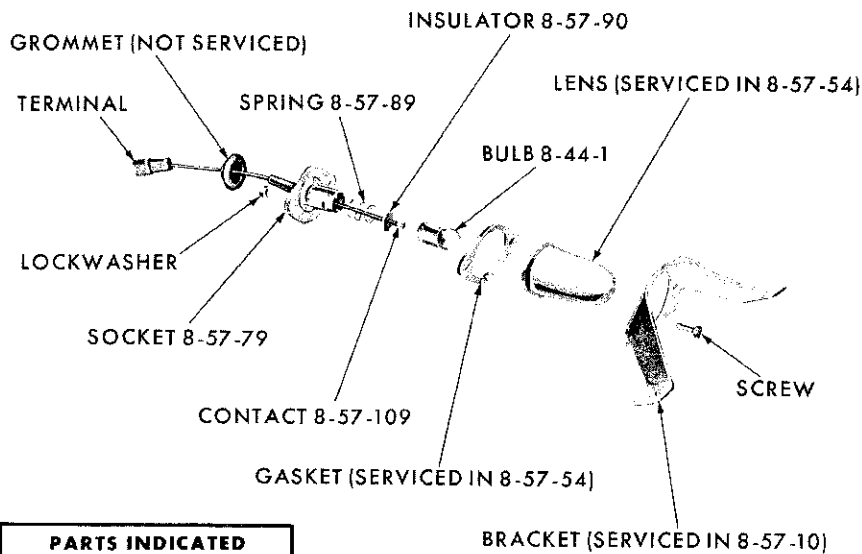

**PARTS INDICATED  
BY NAME ONLY - ORDER  
BY DESCRIPTION**

19x9188

LICENSE LAMP - VALIANT SV1 AND LANCER SL1



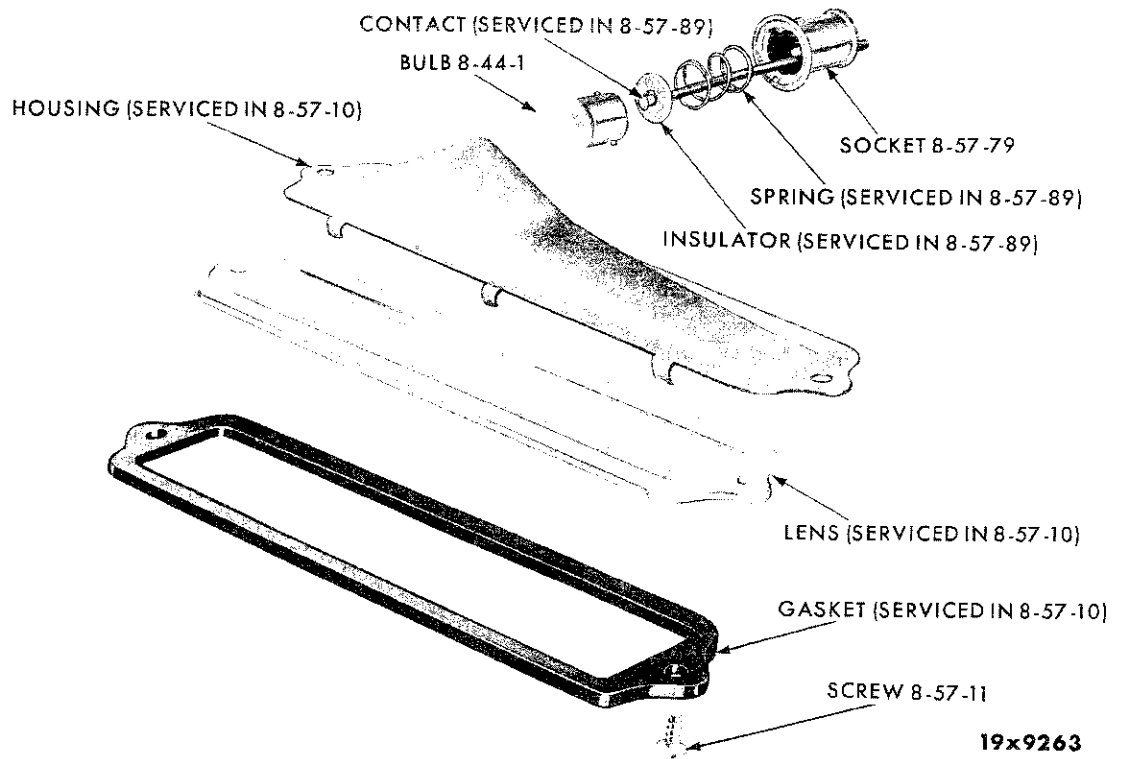

LICENSE LAMP - DODGE SD1-2 (EXCEPT SUBURBAN)

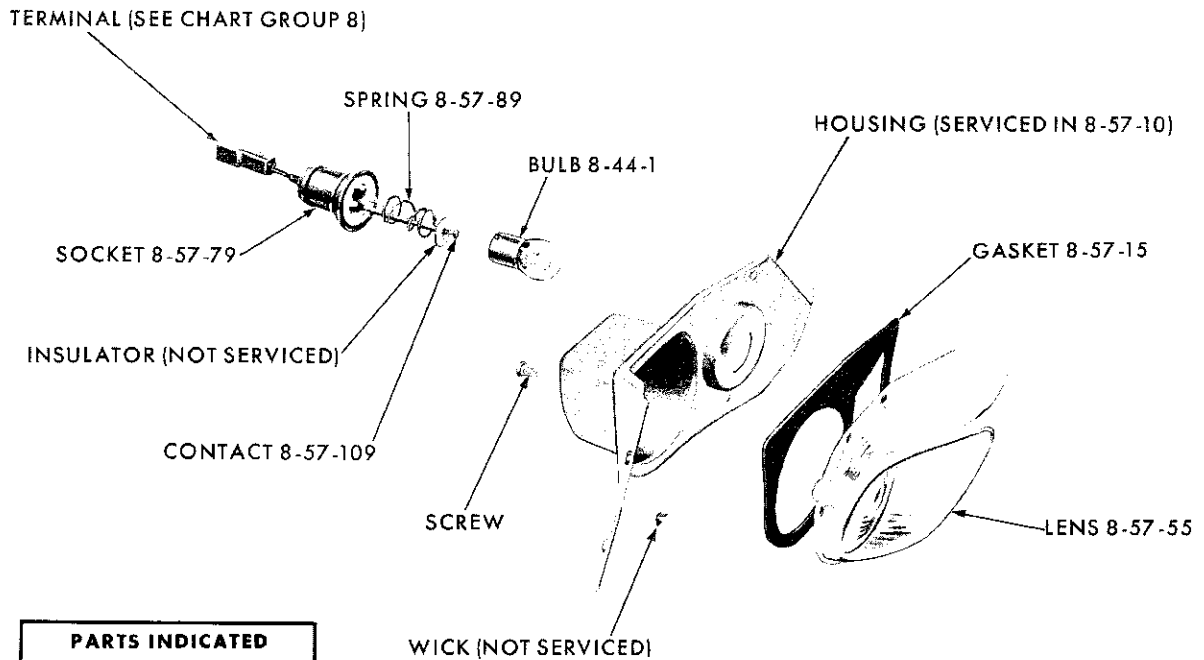

**PARTS INDICATED  
BY NAME ONLY - ORDER  
BY DESCRIPTION**

19x9179

LICENSE LAMP - DODGE SD1-2 (SUBURBAN)

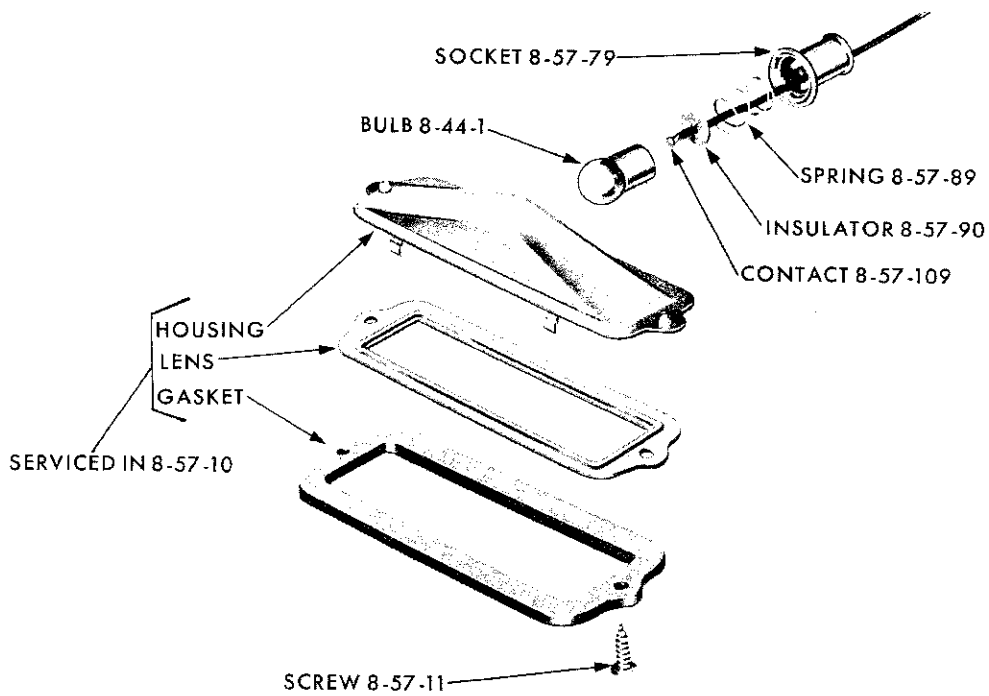

19x9218

LICENSE LAMP - CHRYSLER SC1-2-3 (EXCEPT SUBURBAN)

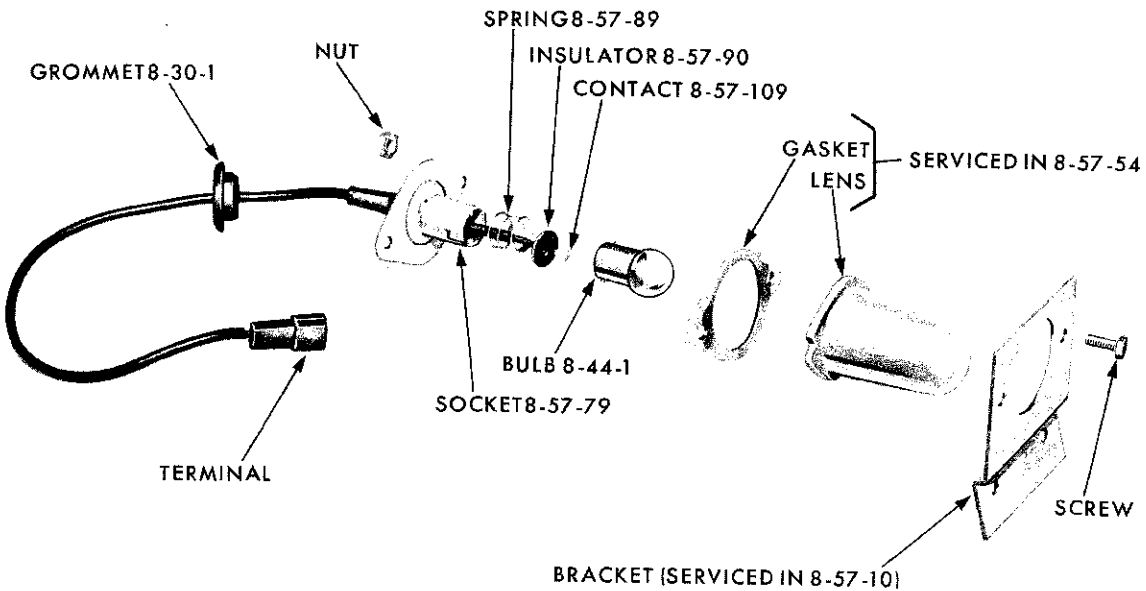

PARTS INDICATED BY NAME ONLY - ORDER BY DESCRIPTION

19x9216

LICENSE LAMP - IMPERIAL SY1

**PARTS INDICATED  
BY NAME ONLY - ORDER  
BY DESCRIPTION**

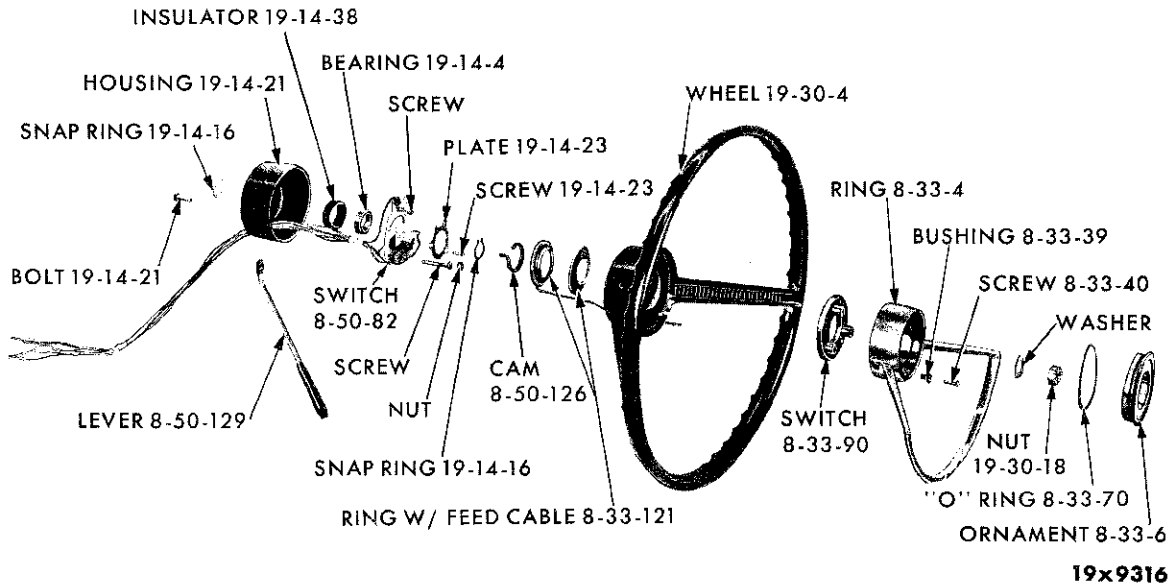

**HORN AND DIRECTIONAL SIGNAL CONTROLS - VALIANT SV1 AND LANCER SL1**

**PARTS INDICATED  
BY NAME ONLY - ORDER  
BY DESCRIPTION**

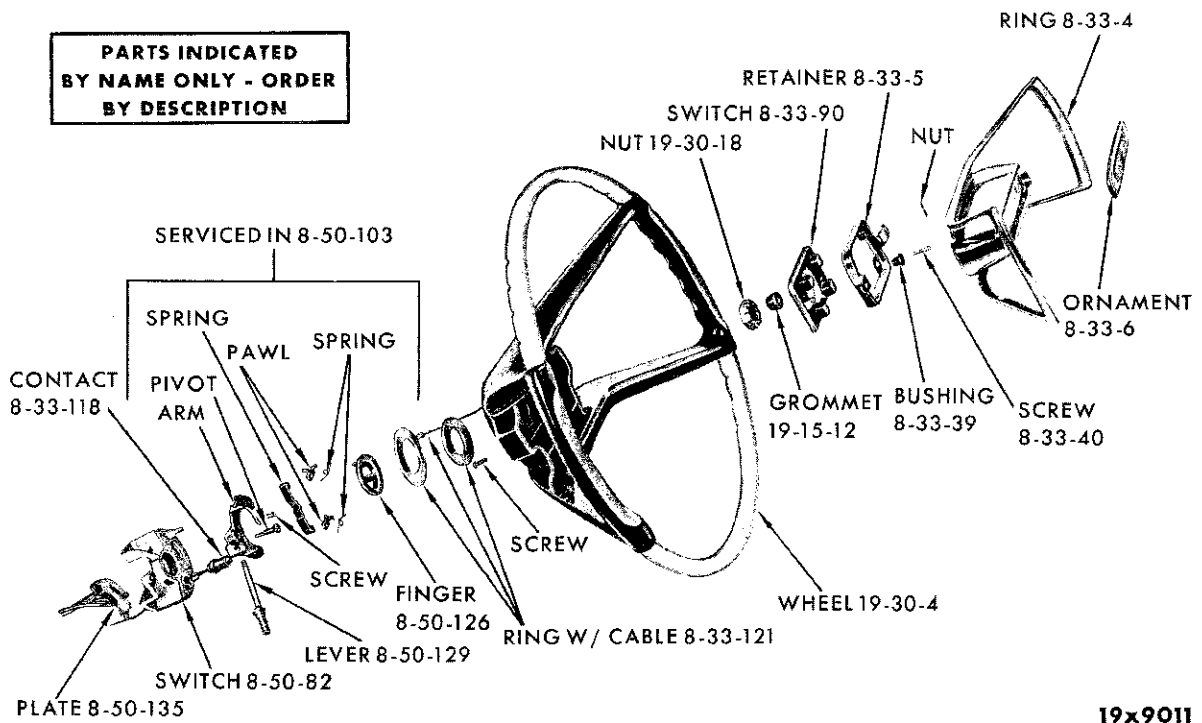

**HORN AND DIRECTIONAL SIGNAL CONTROLS - DODGE SD3**

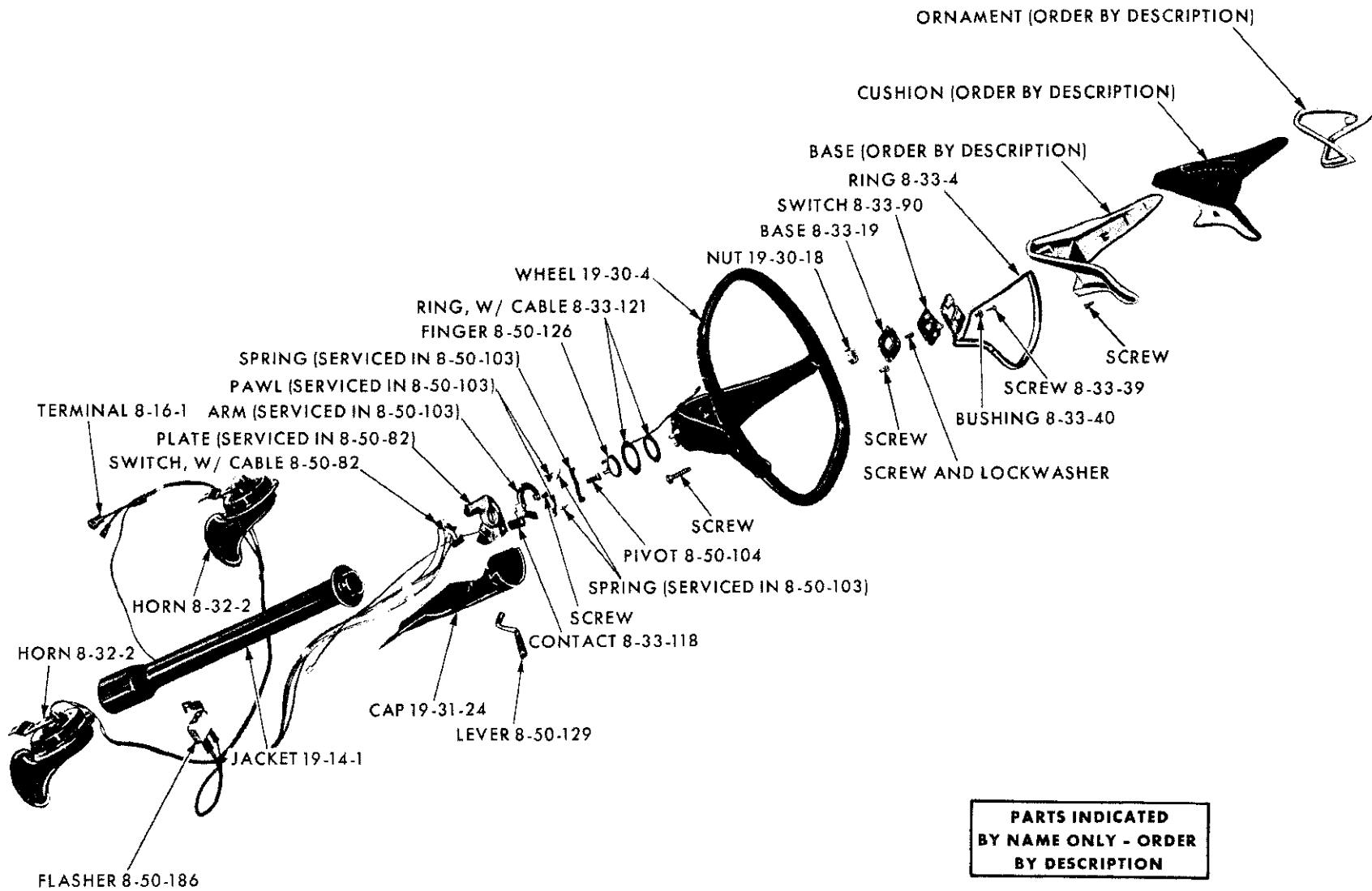

19x9363

HORN AND DIRECTIONAL SIGNAL CONTROLS - IMPERIAL SY1

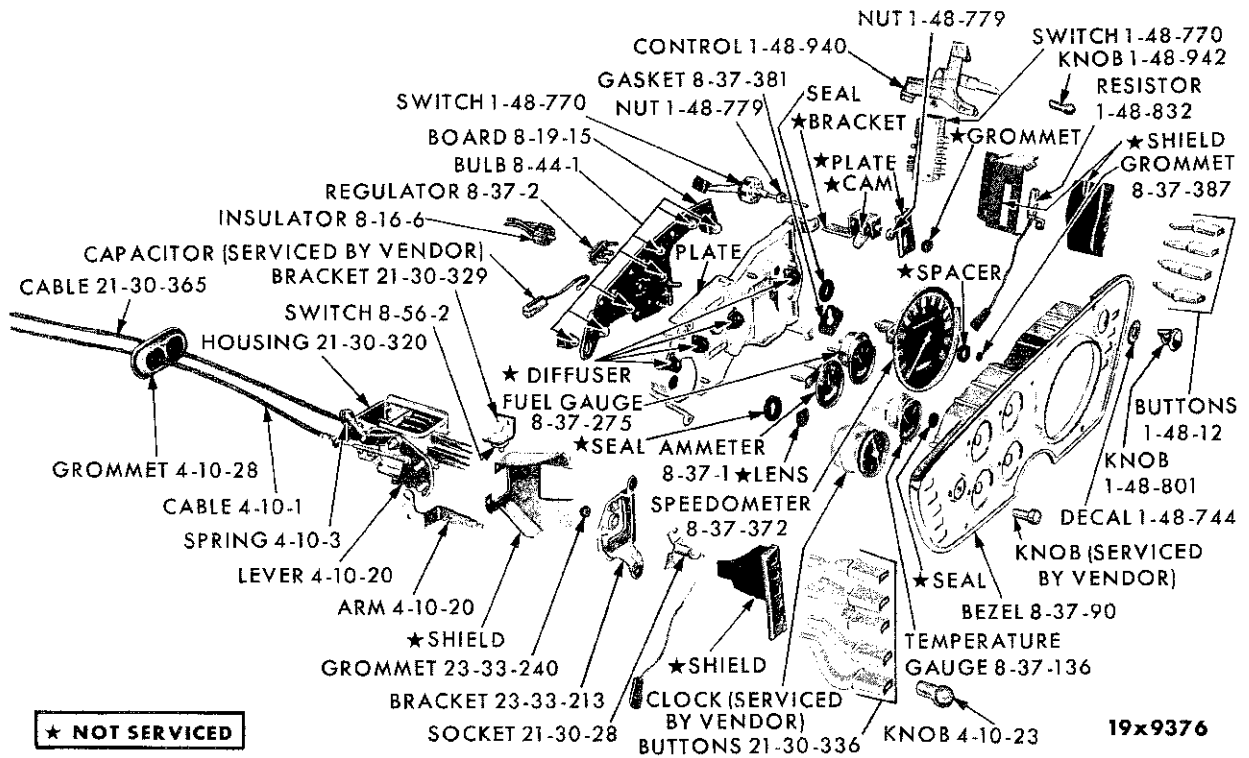

INSTRUMENT CLUSTER - PLYMOUTH SP1-2

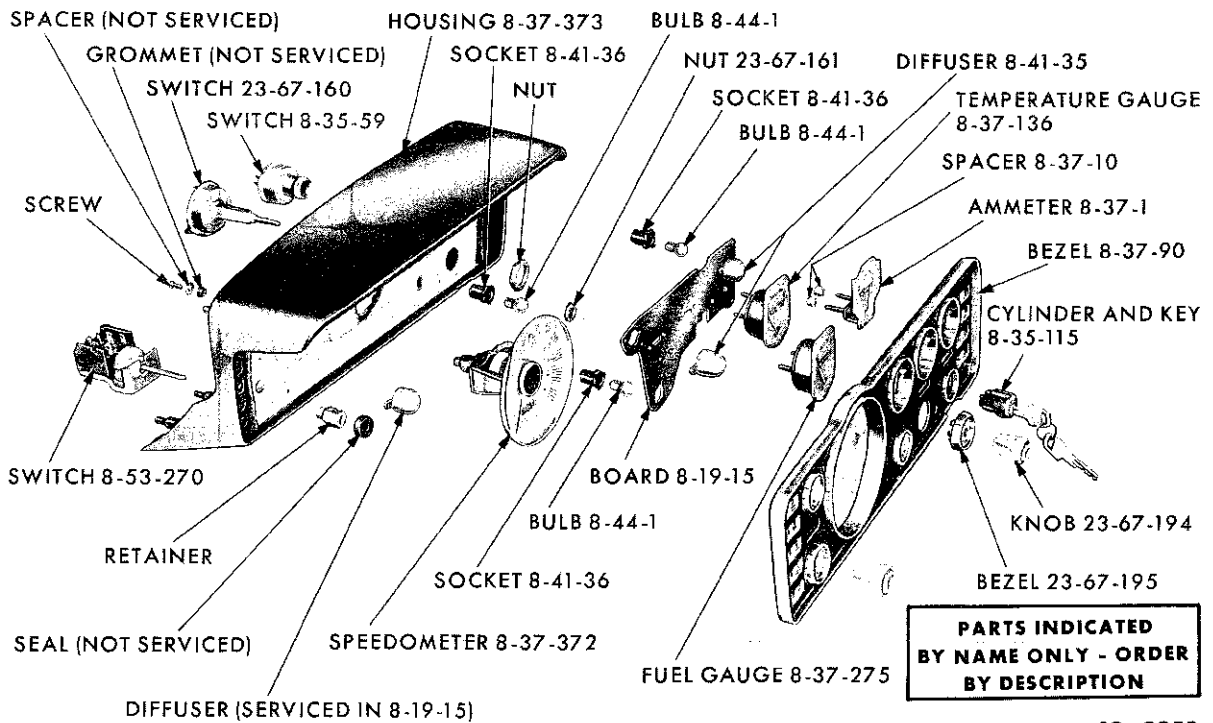

INSTRUMENT CLUSTER - VALIANT SV1

**PARTS INDICATED  
BY NAME ONLY - ORDER  
BY DESCRIPTION**

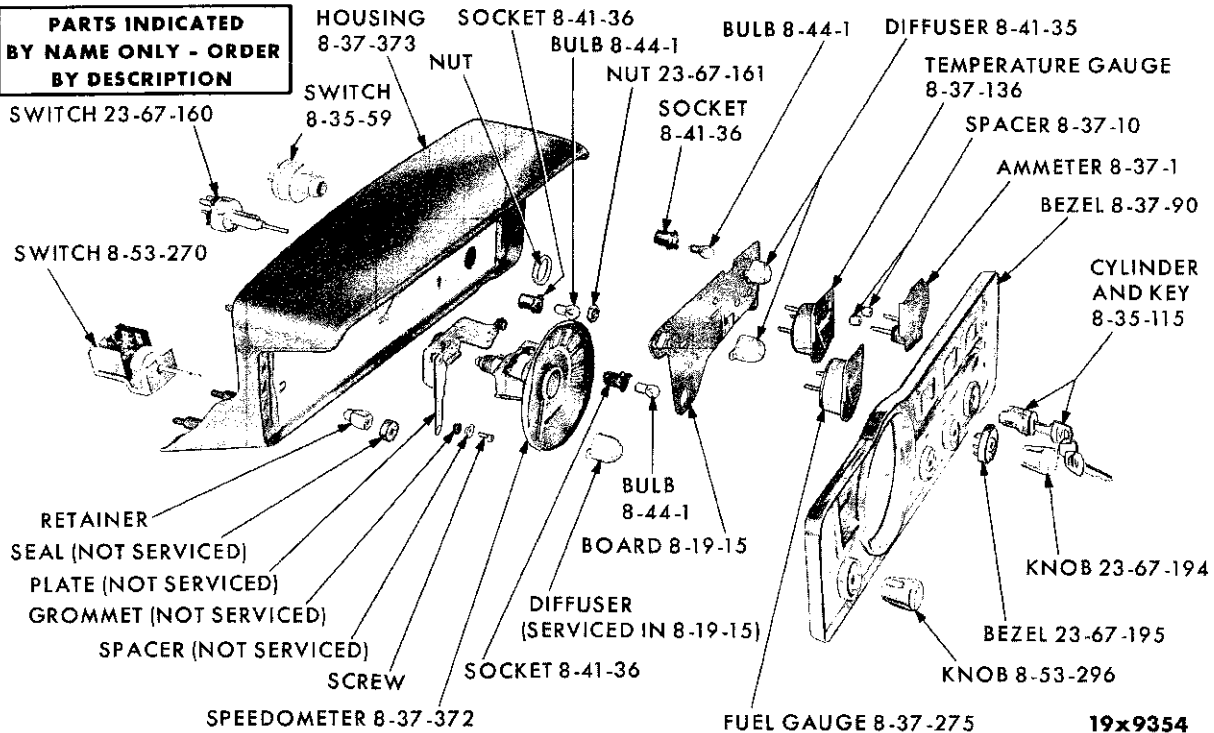

INSTRUMENT CLUSTER - LANCER SL1

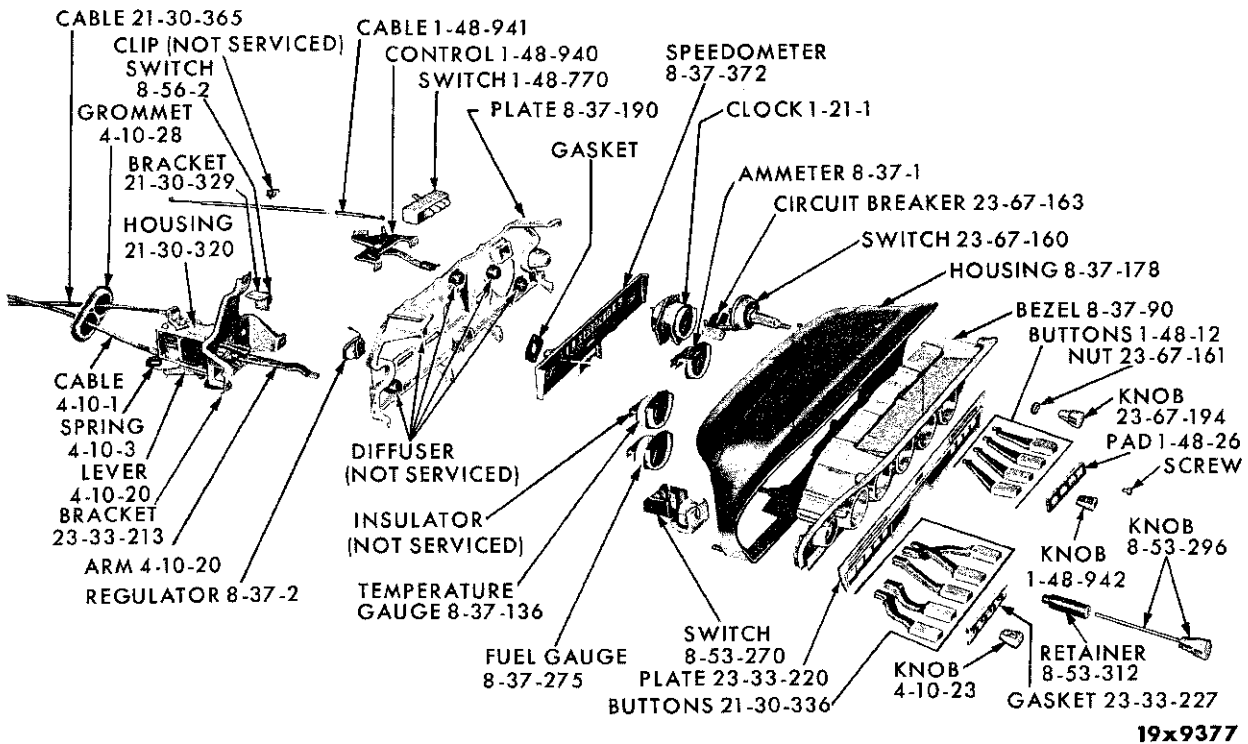

INSTRUMENT CLUSTER - DART SD1-2

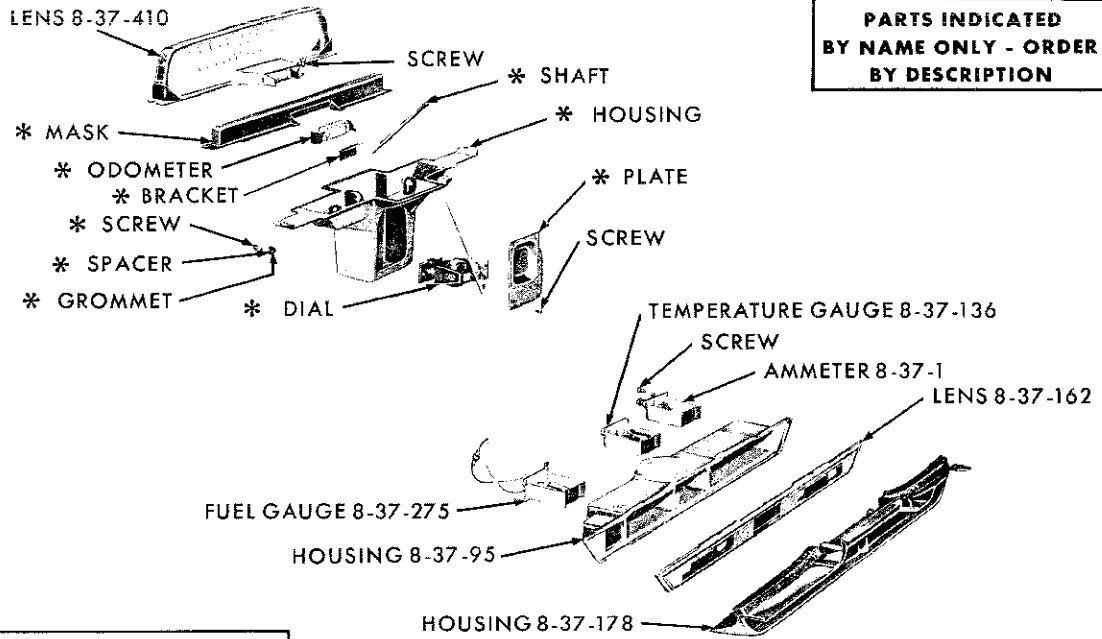

PARTS INDICATED BY NAME ONLY - ORDER BY DESCRIPTION

\* SERVICED IN 8-37-372

19x9026A

INSTRUMENT CLUSTER - DODGE SD3

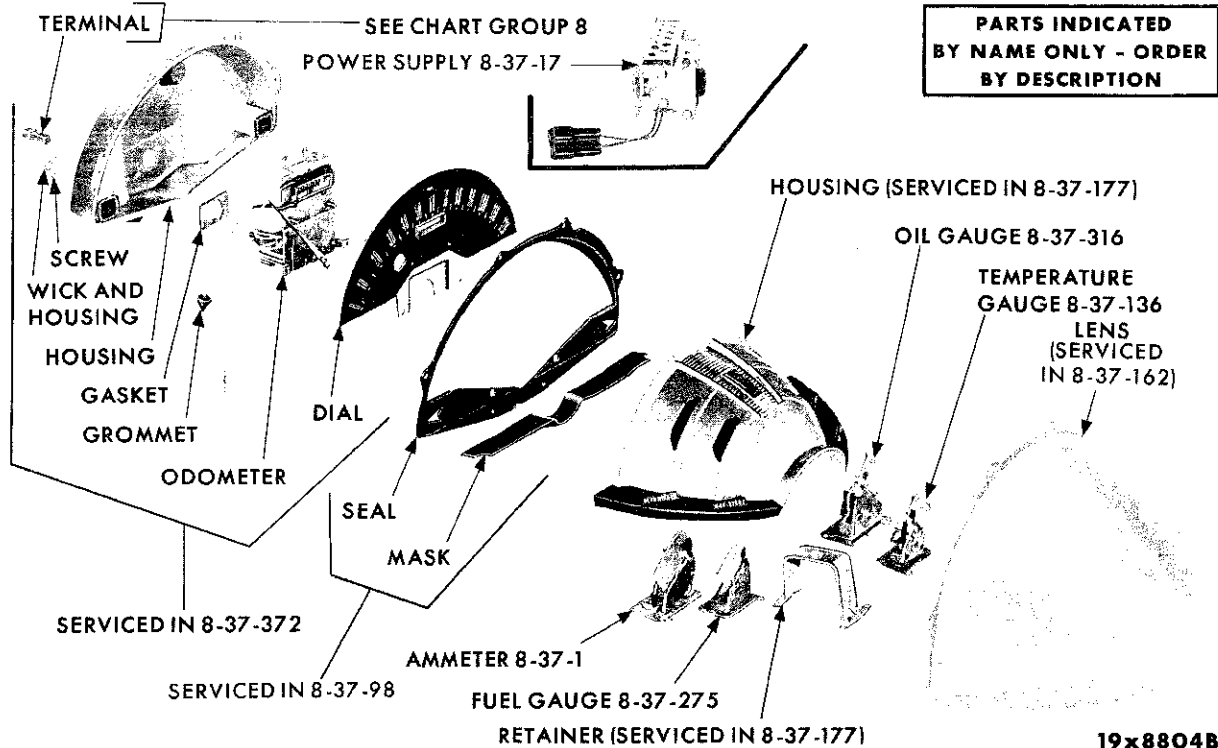

PARTS INDICATED BY NAME ONLY - ORDER BY DESCRIPTION

SERVICED IN 8-37-372

SERVICED IN 8-37-98

19x8804B

INSTRUMENT CLUSTER - CHRYSLER SC1-2-3

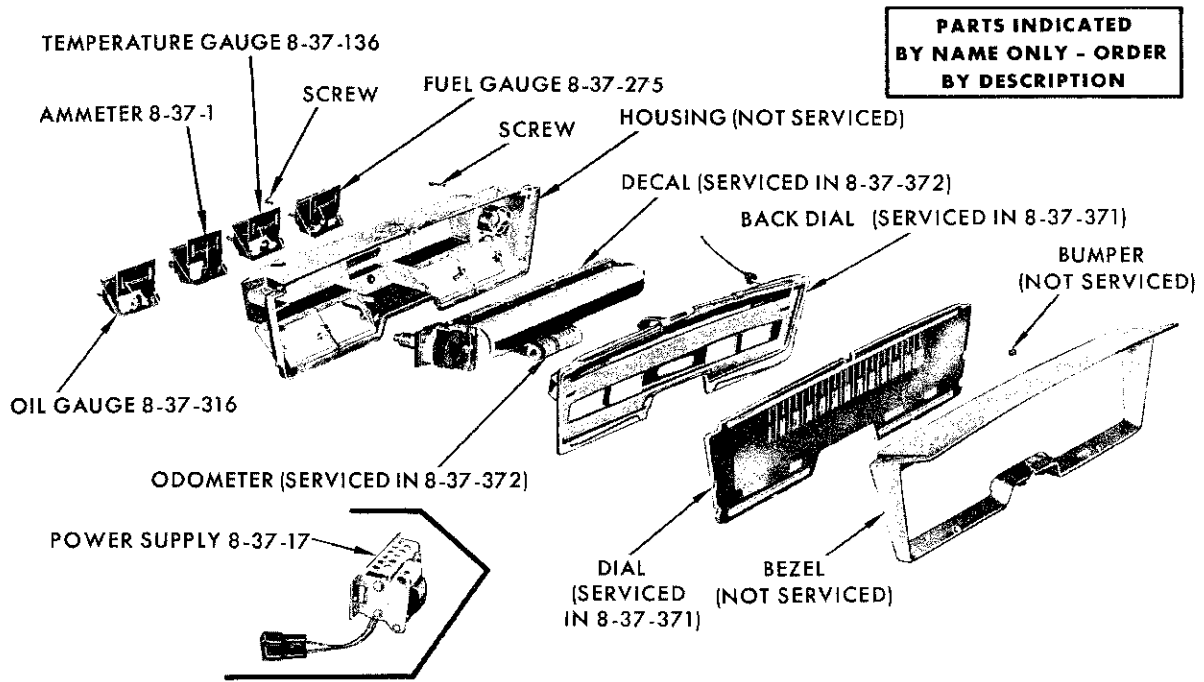

19x9014B

INSTRUMENT CLUSTER - IMPERIAL SY1

NOTES

---

---

---

---

---

---

---

---

---

---

---

---

---

---

---

---

---

---

---

---

---









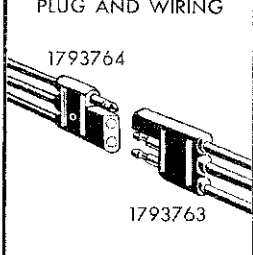
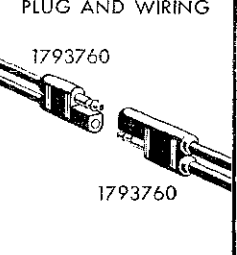
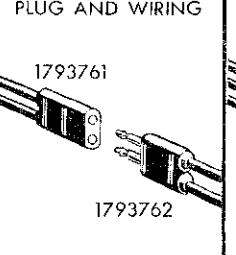
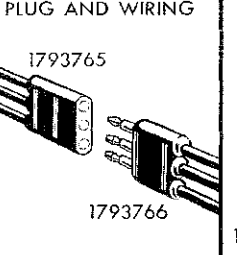
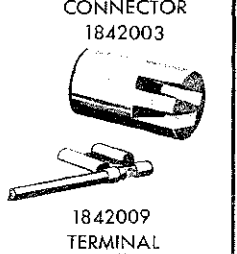
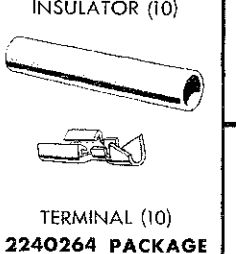

---

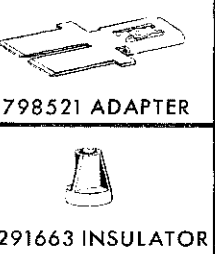
---

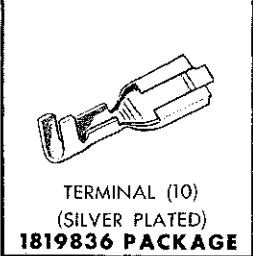
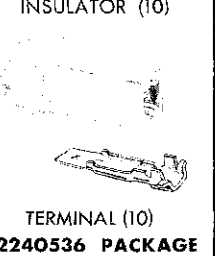
---

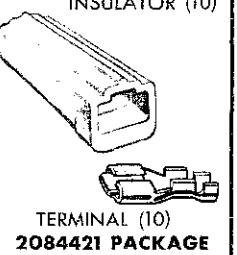
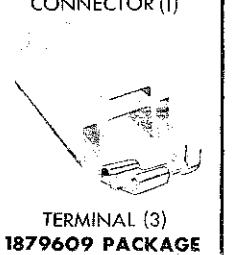
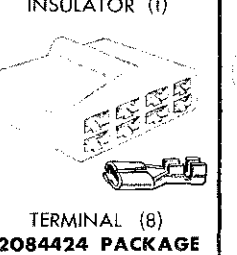
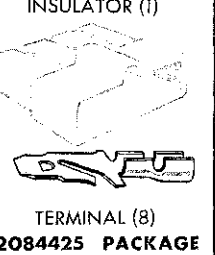
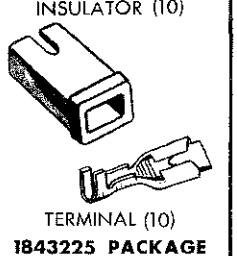
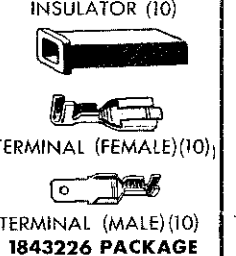
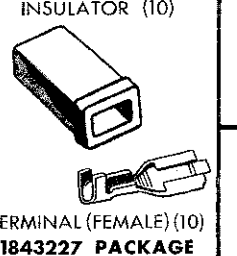
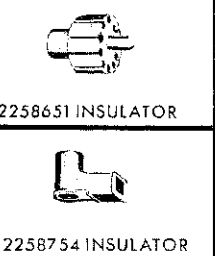
---



<p>PLUG AND WIRING</p>  <p>1793764 1793763</p>	<p>PLUG AND WIRING</p>  <p>1793760 1793760</p>	<p>PLUG AND WIRING</p>  <p>1793761 1793762</p>	<p>PLUG AND WIRING</p>  <p>1793765 1793766</p>	 <p>1819362 CONNECTOR</p>
<p>CONNECTOR (10)</p>  <p>TERMINAL (20) <b>1843444 PACKAGE</b></p>	<p>CONNECTOR 1842003</p>  <p>1842009 TERMINAL</p>	<p>INSULATOR (10)</p>  <p>TERMINAL (10) <b>2240264 PACKAGE</b></p>	<p>1770660 TERMINAL</p>  <p>200156 TERMINAL</p> 	<p>1798521 ADAPTER</p>  <p>2291663 INSULATOR</p> 
<p>TERMINAL (10) (SILVER PLATED) <b>1819836 PACKAGE</b></p> 	<p>TERMINAL (10) <b>1779654 PACKAGE</b></p> 	<p>INSULATOR (1)</p>  <p>TERMINAL (6) <b>1843222 PACKAGE</b></p>	<p>INSULATOR (1)</p>  <p>TERMINAL (6) <b>1843223 PACKAGE</b></p>	<p>INSULATOR (10)</p>  <p>TERMINAL (10) <b>2240536 PACKAGE</b></p>
<p>TERMINAL (FEMALE)</p>  <p>INSULATOR (FEMALE) TERMINAL (MALE)</p>  <p>INSULATOR (MALE) <b>2298882 PACKAGE</b></p>	<p>INSULATOR (10)</p>  <p>TERMINAL (10) <b>2084421 PACKAGE</b></p>	<p>CONNECTOR (1)</p>  <p>TERMINAL (3) <b>1879609 PACKAGE</b></p>	<p>INSULATOR (1)</p>  <p>TERMINAL (8) <b>2084424 PACKAGE</b></p>	<p>INSULATOR (1)</p>  <p>TERMINAL (8) <b>2084425 PACKAGE</b></p>
<p>INSULATOR (10)</p>  <p>TERMINAL (20) <b>1843224 PACKAGE</b></p>	<p>INSULATOR (10)</p>  <p>TERMINAL (10) <b>1843225 PACKAGE</b></p>	<p>INSULATOR (10)</p>  <p>TERMINAL (FEMALE) (10); TERMINAL (MALE) (10) <b>1843226 PACKAGE</b></p>	<p>INSULATOR (10)</p>  <p>TERMINAL (FEMALE) (10) <b>1843227 PACKAGE</b></p>	<p>2258651 INSULATOR</p>  <p>2258754 INSULATOR</p> 
 <p>2258591 TERMINAL</p>	 <p>2258118 TERMINAL</p>	 <p>2290069 TERMINAL</p>		
 <p>2258102 INSULATOR</p>	 <p>2258590 TERMINAL</p>	 <p>2290207 TERMINAL</p>		

NUMBERS IN PARENTHESIS INDICATE QUANTITY INCLUDED IN PACKAGE

19x9051D

CLIP CHART

# MoPar BATTERIES

Now, longer battery life is assured in the car or on the shelf because all plates in new MoPar Batteries are sealed with a super-hard coating of silver and cobalt to resist internal corrosion caused by overcharging. A new Plastic Seal on the positive terminal assures customers that every MoPar Battery is sealed at the factory and remains sealed until installed for use. The peak power and performance manufactured into each MoPar Battery cannot be used until this seal is broken.



ELECTROLYTE  
1843 124 QT.  
2084 649 5 GAL.

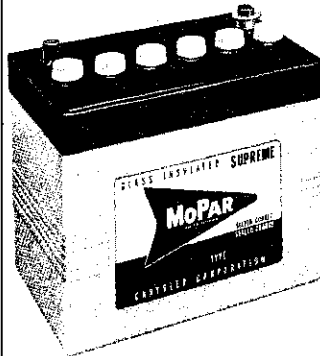

MoPar SUPREME - The ultimate in POWER-PLUS service - the highest quality battery available for longest life!

- SILVER-COBALT SEALED PLATES
- SPUN-GLASS INSULATION



MoPar DELUXE - A power-packed battery to meet the demands of the greatest number of drivers.

- SILVER-COBALT SEALED PLATES
- BIPLAK INSULATION



MoPar SPECIAL - Ideal for cost-conscious customers. Perfect for your used cars. . . LOW PRICED and a natural leader to attract battery prospects.

- SILVER-COBALT SEALED PLATES
- BIPLAK INSULATION

1962	TYPE	WET	DRY	WET	DRY	WET	DRY
		CHARGED	CHARGED	CHARGED	CHARGED	CHARGED	CHARGED
VALIANT AND LANCER HEAVY DUTY	20H	-	-	2098 447	2098 448	-	-
	24	2098 039	2098 030	2098 041	2098 042	2098 053	-
PLYMOUTH AND DODGE STANDARD HEAVY DUTY	24	2098 029	2098 030	2098 041	2098 042	2098 053	-
	27H	2098 039	2098 040	2098 051	2098 052	-	-
CHRYSLER NEWPORT AND 300 STANDARD HEAVY DUTY NEW YORKER	24	2098 029	2098 030	2098 041	2098 042	-	-
	27H	2098 039	2098 040	2098 051	2098 052	-	-
	27H	2098 039	2098 040	2098 051	2098 052	-	-
IMPERIAL ALL	27H	2098 039	2098 040	2098 051	2098 052	-	-

FOR COMPLETE PAST MODEL APPLICATION AND FOR OTHER MAKE VEHICLES SEE MOPAR BATTERY CHART AND PRICE LIST

CODE	PART NAME AND DESCRIPTION	CYL	PER CAR	VALIANT LANCER	PLYMOUTH DODGE	CHRYSLER IMPERIAL
<b>8-01-O BATTERY AND CABLE</b>						
8-01-4	CABLE, Battery Ground, 41" long . . . . .	6	1	1879 945	1879 945	
	23" long . . . . .	8	1	----	1879 944	1879 944
8-01-7	CLIP, Battery Cable, Left Side Rail Front Reinforcement, SP2, SP2 . . . . .	8	1	----	6015 242	
8-01-9	CABLE, Jumper, 35" long, No. 14 Gauge . . . . .		★	2275 200	2275 200	2275 200
8-01-11	BOLT, Battery Ground Cable Clamp . . . . .		1	1622 535	1622 535	1622 535
8-01-12	NUT, Battery Ground Cable Clamp Bolt . . . . .		1	1622 536	1622 536	1622 536
8-01-17	CABLE, Battery to Starter, 23" long . . . . .	6	1	1879 944		
	41" long . . . . .	6	1	----	1879 945	
	Except 413 cu. in. Eng., SP2, SD2, 48" long. . .	8	1	----	*2230 938	
	w/413 cu. in. Eng., SP2, SD2, 41" long . . . . .	8	1	----	*1879 945	
	Battery to Starter Relay, 23" long, SD3 . . . . .	8	1	----	1879 944	1879 944
	Starter Relay to Starter, 29" long, SD3 . . . . .	8	1	----	1879 938	1879 938
8-01-20	BOLT, Battery to Starter Cable Clamp . . . . .		1	1622 535	1622 535	1622 535
8-01-21	NUT, Battery to Starter Cable Clamp Bolt . . . . .		1	1622 536	1622 536	1622 536
8-01-23	SCREW, Battery Cable Clip, Battery Tray . . . . .	6	1	----	6022 503	
	Left Side Shield . . . . .	8	1	----	----	6006 121
8-01-25	NUT, Battery Cable Clip, Battery Tray . . . . .	6	1	----	6010 006	
<b>8-05-O DOME LAMP AND SWITCH</b>						
8-05-6	HOUSING, Dome Lamp, Sub. . . . .	6	1	2259 366		
	Except Cv. Cp., SC1, SC2, SC3 . . . . .		1	----	1963 603	1963 603
	w/SWITCH, Rear, Sub., SC1, SC3 . . . . .		1	----	2161 308	2161 308
	Sp. 4 D. and Sp. Cl. Cp., SY1 . . . . .	8	1	----	----	1902 237
8-05-8	BEZEL, Dome Lamp, except Cv. Cp., SC1, SC2, SC3 . . . . .		1	----	2166 743	2166 743
	BEZEL and LENS, Rear, Sub., SC1, SC3 . . . . .		1	----	2161 307	2161 307
8-05-11	RETAINER, Dome Lamp Switch, SD1, SD2 . . . . .		1	----	2258 755	
8-05-12	SOCKET, Dome Lamp . . . . .	6	1	1704 875		
	w/BRACKET, except Cv. Cp., SC1, SC2, SC3 . .		1	----	2096 499	2096 499
	Sp. 4 D. and Sp. Cl. Cp., SY1 . . . . .	8	1	----	----	1704 875
8-05-14	SWITCH, Dome Lamp, SP1, SP2, SD1, SD2 . . . . .		1	2298 855	2275 587	
	SD3 . . . . .	8	1	----	2209 329	
	Sp. Cl. Cp. and Sp. 4 D., SY1 . . . . .	8	1	----	----	2096 180
8-05-16	KNOB and STEM PACKAGE, Dome Lamp Switch Control, SL1 . . . . .	6	1	2275 585		
	KNOB and STEM PACKAGE, SV1 . . . . .	6	1	2298 883		
	KNOB, SP1, SP2 . . . . .		1	----	2258 211	
	SD1, SD2, SY1 . . . . .		1	----	2197 383	2258 027
	SD3 . . . . .	8	1	----	2257 477	
	w/STEM, SC1, SC2, SC3 . . . . .	8	1	----	----	2257 951
	w/o Stem, SC1, SC2, SC3 . . . . .	8	1	----	----	2257 955
8-05-17	SPRING, Dome Lamp Switch Knob Retainer . . . . .	6	1	2076 145		
8-05-20	BEZEL, Dome Lamp Switch, SP1, SP2, SY1 Sp. Cl. Cp. and Sp. 4 D. . . . .		1	----	2256 432	2096 181
	SD3 . . . . .	8	1	----	*2097 503	

★ Indicates use as required. Numerals in parentheses ( ) refer to notes. Printed in U.S.A.  
 □ Indicates parts not listed in any previous parts book. Prices and specifications subject to change without notice.  
 \* Indicates change or addition. March 8, 1963 Supersedes May 1, 1962.

# 1962 PASSENGER CAR PARTS CATALOG

ELECTRICAL

CODE	PART NAME AND DESCRIPTION	CYL.	PER CAR	VALIANT LANCER	PLYMOUTH DODGE	CHRYSLER IMPERIAL
<b>8-05-0 DOME LAMP AND SWITCH- Cont'd</b>						
8-05-23	LENS, Dome Lamp . . . . .	6	1	2082 579		
	Except Cv. Cp., SC1, SC2, SC3 . . . . .		1	----	2166 676	2166 676
	Sp. 4 D. and Sp. Cl. Cp., SY1 . . . . .	8	1	----	----	1902 298
8-05-24	NUT, Dome Lamp Switch Mounting, SC1, SC2, SC3 . . . . .	8	1	----	----	1971 521
8-05-28	BRACKET, Dome Lamp Mounting, Rear, Sub., SC1, SC3 . . . . .		1	----	2086 597	2086 597
	SUPPORT, w/o Extension, 2 D and 4 D . . . . .		1	----	2162 502	
	SUPPORT, Sp. 4 D and Sp. Cl. Cp., SY1 . . . . .	8	1	----	----	2419 000
	BRACKET, Housing, Sp. 4 D and Sp. Cl. Cp., SY1 . . . . .	8	1	----	----	1961 031
8-05-29	EXTENSION, Dome Lamp Support, 2 D. and 4 D. . . . .		1	----	2292 992	
8-05-31	CONTACT, Socket . . . . .		★	2256 966	2256 966	2256 966
8-05-32	CORE, Dome Lamp Socket, Rear, Sub., SC1, SC3 . . . . .		1	----	2161 316	2161 316
<b>8-11-0 QUARTER OR COURTESY LAMP</b>						
8-11-6	SWITCH, Courtesy Lamp, on Console, SP2-P, SD2-P . . . . .	8	1	----	2291 106	
8-11-8	SOCKET and WIRES, Rear Pocket Panel Courtesy Lamp, CV. Cp., SP2, SD2, SY1 . . . . .		2	----	1963 479	1963 479
	Floor Console, SP2-P, SD2-P . . . . .	8	1	----	1963 479	
	Quarter Arm Rest Courtesy Lamp, Cv. Cp., SD3, SC1, SC2 . . . . .	8	2	----	1963 479	1963 479
8-11-11	NUT, Courtesy Lamp Switch Mounting, on Console, SP2-P, SD2-P . . . . .	8	1	----	2291 107	
8-11-12	LENS and RETAINER, Rear Pocket Panel Courtesy Lamp Bezel, Cv. Cp., SP2, SD2, SY1 . . . . .	8	2	----	1623 132	1623 132
	Floor Console, SP2-P, SD2-P . . . . .	8	1	----	1623 132	
	Quarter Arm Rest Courtesy Lamp, Cv. Cp., SD3, SC1, SC2 . . . . .	8	2	----	1623 132	1623 132
<b>8-12-0 AUTOMATIC DOOR LAMP SWITCH</b>						
8-12-1	LAMP, Open Door Indicator, 4 D. . . . .		1	2298 767	2298 767	
8-12-2	SWITCH, Automatic Door Lamp, w/Elbow Type Sleeve Connector . . . . .		2	1972 329	1972 329	1972 329
	w/Straight Type Sleeve Connector . . . . .		2	1971 931	1971 931	*1971 931
8-12-3	SOCKET, Open Door Indicator Lamp, 4 D. Taxi . . . . .		1	1314 619	1314 619	
8-12-17	CONTACT, Open Door Indicator Light Socket . . . . .		★	*2256 966	*2256 966	*2256 966
<b>8-13-0 TRUNK LAMP</b>						
8-13-1	SWITCH, Socket and Cable, Trunk Lamp, SY1 . . . . .	8	1	----	----	1770 786
8-13-2	SWITCH, Trunk Lamp, except Sub., SC1, SC2, SC3 . . . . .		1	1972 426	1972 426	1972 426
8-13-3	SOCKET and BRACKET, Trunk Lamp, except Sub., SC1, SC2, SC3 . . . . .		1	2096 857	2096 857	2096 857
8-13-4	SPRING, Trunk Lamp Socket . . . . .		★	1842 340	1842 340	1842 340
8-13-5	INSULATOR, Trunk Lamp Socket . . . . .		★	858 245	858 245	858 245
8-13-6	CONTACT, Trunk Lamp Socket . . . . .		★	*2256 966	*2256 966	*2256 966

★ Indicates use as required. Numerals in parentheses ( ) refer to notes. Printed in U.S.A.  
 ☐ Indicates parts not listed in any previous parts book. Prices and specifications subject to change without notice.  
 March 8, 1963 Supersedes May 1, 1962. \* Indicates change or addition.

CODE	PART NAME AND DESCRIPTION	CYL.	PER CAR	VALIANT LANCER	PLYMOUTH DODGE	CHRYSLER IMPERIAL
<b>8-15-0 CHASSIS AND BODY WIRING</b>						
8-15-2	WIRING, Headlamp and Engine Compartment, SL1, SP1, SP2, SC1, SC2, SC3 . . . . .		1	*2258 439	*2258 425	*2290 132
	SV1, SD1, SD2, SY1 . . . . .		1	*2258 402	*2258 399	*2290 199
	Engine, SP1, SP2 except 413 cu. in. Eng., SD1, SD2 except 413 cu. in. Eng. . . . .		1	*2258 406	*2258 423	
	Engine, w/413 cu. in. Eng., SP2, SD2 . . . . .	8	1	----	E2291 919	
	Headlamp and Engine, SD3 . . . . .	8	1	----	*2426 146	
8-15-3	BLOCK, w/Mounting Bracket, Fuse, SY1 . . . . .		1	2258 395	2258 395	2258 395
	SC1, SC2, SC3 . . . . .	8	1	----	----	2257 102
8-15-4	WIRING, Body, w/o Back-Up Lamp, except Sub., SV1 . . . . .	6	1	2258 993		
	w/Back-Up Lamp, except Sub., SV1 . . . . .	6	1	2258 994		
	w/Back-Up Lamp, except Sub., SL1 . . . . .	6	1	2290 003		
	w/o Back-Up Lamp, except Sub., SL1 . . . . .	6	1	2258 902		
	w/Tailgate, Sill, Sub. . . . .	6	1	2258 879		
	Sill, Sub. . . . .	6	1	2258 886		
	w/Tailgate, Rear, Sub., SV1 . . . . .	6	1	2258 850		
	Rear, Sub., SV1 . . . . .	6	1	2290 008		
	Front, except Sub., SP1, SP2, SD1, SD2 . . . . .		1	----	2258 089	
	Rear, w/Back-Up Lamp, except Sub., SP1-L-M, SP2-L-M . . . . .		1	----	2258 090	
	Rear, w/o Back-Up Lamp, except Sub., SP1-M, SP2-M . . . . .		1	----	2291 412	
	Rear, w/o Back-Up Lamp, except Sub., SP1-L, SP2-L . . . . .		1	----	2258 092	
	Rear, w/Back-Up Lamp, except Sub., SP1-H, SP2-H-P . . . . .		1	----	2291 801	
	Rear, SD2-P . . . . .	8	1	----	2291 054	
	Console Wiring Console, SP2-P, SD2-P . . . . .	8	1	----	2291 078	
	Rear, except Sub., SD1, SD2 . . . . .		1	----	2258 084	
	Sub., SP1, SP2, SD1, SD2, SC1, SC3 . . . . .		1	----	2258 076	2258 202
	Sub., SD3 . . . . .	8	1	----	2258 202	
	w/Tailgate, Sub., SD3 . . . . .	8	1	----	2258 731	
	w/Tailgate, Sub., SP1, SP2, SD1, SD2, SC1, SC3 . . . . .		1	----	2258 196	2258 731
	Front, except Sub., SD3, SC1, SC2, SC3 . . . . .	8	1	----	2258 677	2258 677
	Rear, except Sub., SD3, SC1, SC2, SC3 . . . . .	8	1	----	2258 008	2258 008
	Rear, SY1 . . . . .	8	1	----	----	2258 111
	Front, Cv. Cp., SY1 . . . . .	8	1	----	----	2290 133
	Front, Sp. 4 D. and Sp. Cl. Cp., SY1 . . . . .	8	1	----	----	2290 134
8-15-7	FUSE WIRE, Alternator Voltage Regular . . . . .		1	2275 242	2275 242	2275 242
8-15-13	COVER, Fuse Block, SC1, SC2, SC3 . . . . .	8	1	----	----	2258 860
8-15-32	CLIP, Engine Headlamp Wiring, Front Extension . . . . .		1	----	6015 288	
	Dome Lamp Wiring, except Cv. Cp. . . . .		1	----	6015 288	
	Connector Retaining . . . . .		*	2291 662	2291 662	2291 662
	Body Wiring, SY1 . . . . .	8	1	----	----	6015 288
8-15-33	SCREW and CLAMP, Wiring Bulkhead Disconnect Terminal . . . . .		*	2258 751	2258 751	2258 751
	Fuse Block Mounting, SC1, SC2, SC3 . . . . .	8	2	----	----	1901 828
8-15-52	WIRING, Rear Lamp, Sub., SP1, SP2 . . . . .		1	----	2258 074	
	Rear Lamp, Sub., SD3, SC1, SC3 . . . . .	8	1	----	2258 203	2258 203
	w/Tailgate, Sub., SP1, SP2 . . . . .		1	----	2258 197	
	w/Tailgate, Sub., SD1, SD2 . . . . .		1	----	2258 198	
8-15-53	WIRING, Dome Lamp, Sp. 4 D., SY1 . . . . .	8	1	----	----	2198 871

★ Indicates use as required.

Numerals in parentheses ( ) refer to notes.

Printed in U.S.A.

E Indicates parts not listed in any previous parts book.

Prices and specifications subject to change without notice.

\* Indicates change or addition.

CODE	PART NAME AND DESCRIPTION	C Y L.	PER CAR	VALIANT LANCER	PLYMOUTH DODGE	CHRYSLER IMPERIAL
------	---------------------------	--------------	------------	-------------------	-------------------	----------------------

## 8-16-0 CABLE AND CONNECTIONS

NOTE: For a more practical and economical method of servicing, only the more complicated Assemblies will be stocked for service. These will be found in their respective groups. On the more simple Assemblies the required length and size of Cable, necessary Terminals, etc., should be specified. For visual chart of Insulator and Terminal Packages see front of group.

8-16-1	CONNECTOR and TERMINAL PACKAGE, Headlamp Cable . . . . .	★	1879 609	1879 609	1879 609
	Terminal and Insulator Package, 6 Pole Disconnect Male . . . . .	★	1843 222	1843 222	1843 222
	Single Pole, Long . . . . .	★	1843 226	1843 226	1843 226
	Single Pole, Short . . . . .	★	1843 227	1843 227	1843 227
	Female, Miniature . . . . .	★	2084 421	2084 421	2084 421
	8 Pole Male . . . . .	★	2084 425	2084 425	2084 425
	8 Pole Female . . . . .	★	2084 424	2084 424	2084 424
	Female, Miniature . . . . .	★	2240 264	2240 264	2240 264
	Male, Miniature . . . . .	★	2240 536	2240 536	2240 536
	Male and Female . . . . .	★	2298 882	2298 882	2298 882
8-16-3	CABLE, No. 8 Brown, 100 Foot Spool . . . . .	★	*2275 220	*2275 220	*2275 220
	No. 12 Red, 100 Foot Spool . . . . .	★	*1752 491	*1752 491	*1752 491
	No. 14 Green, 100 Foot Spool . . . . .	★	*1752 490	*1752 490	*1752 490
	No. 16 Blue, 100 Foot Spool . . . . .	★	*1752 489	*1752 489	*1752 489
	No. 18 Yellow, 100 Foot Spool . . . . .	★	*1752 488	*1752 488	*1752 488
	Horn Cable, No. 16 Black, 100 Foot Spool . . . . .	★	*1064 754	*1064 754	*1064 754
	Wire and Spool, Triple Conductor, No. 14 Gauge, Red, Green and Black, 100 Foot Spool . . . . .	★	*2298 769	*2298 769	*2298 769
	Wire and Spool, Double Conductor, No. 14 Gauge, Green and Black, 100 Foot Spool . . . . .	★	*2298 770	*2298 770	*2298 770
	Wire and Spool, Double Conductor, No. 14 Gauge, Red and Black, 100 Foot Spool . . . . .	★	*2298 768	*2298 768	*2298 768
8-16-4	TERMINAL, Female, Side Type . . . . .	★	1842 009	1842 009	1842 009
	Male Blade Crimped, K-Type . . . . .	★	1753 534	1753 534	1753 534
	Cable Connector . . . . .	★	870 821	870 821	870 821
	Electrical Window Lift Safety Switch Wiring Wiring, .910" long . . . . .	★	903 895	903 895	903 895
	Printed Circuit Wiring, Female . . . . .	★	2258 591	2258 591	2258 591
	Male Blade, K-Type . . . . .	★	2258 118	2258 118	2258 118
	Female Hair Pin Wiring . . . . .	★	1769 280	1769 280	1769 280
	Wiring Fuse Clip . . . . .	★	1779 654	1779 654	1779 654
	Wiring, 1.36" long . . . . .	★	2290 207	2290 207	2290 207
	Wiring, 1.025" long . . . . .	★	2258 590	2258 590	2258 590
	Female, K-Type . . . . .	★	2290 069	2290 069	2290 069
	Male Blade . . . . .	★	1819 836	1819 836	1819 836
	Blade Type . . . . .	★	*1770 660	*1770 660	*1770 660
		★	*1798 521	*1798 521	*1798 521
8-16-5	SLEEVE, Wiring Terminal, Black . . . . .	★	1264 933	1264 933	1264 933
	Starting Motor Terminal . . . . .	1	----	930 304	
	Battery to Starter Relay to Starter Cable Terminal, SD3 . . . . .	1	----	* 930 304	* 930 304
8-16-6	INSULATOR, Alternator Battery Terminal . . . . .	1	*2291 093	*2291 093	*2291 093
	Headlamp Switch, 7 Pole Female . . . . .	★	2258 102	2258 102	2258 102
	Printed Circuit Wiring Terminal . . . . .	★	2258 651	2258 651	2258 651
	Terminal Block . . . . .	★	*2291 663	*2291 663	*2291 663
8-16-8	CONNECTOR, 2 Way Polarized, Female . . . . .	★	1842 003	1842 003	1842 003
	Single Cable . . . . .	★	611 898	611 898	611 898
8-16-10	PLUG, Cable Connector, No. 12 Cable . . . . .	★	665 151	665 151	665 151

★ Indicates use as required.

⊠ Indicates parts not listed in any previous parts book.

May 1, 1962 Supersedes Nov. 30, 1961.

Numerals in parentheses ( ) refer to notes.

Prices and specifications subject to change without notice.

\* Indicates change or addition.

Printed in U.S.A.

**8-17-O FUSES**

CODE	FUSES	AMP.	SIZE	PART NO.
8-17-2	All Models	3	5/8	150 836
	All Models	20	1-1/4	106 653
	All Models	30	1-1/4	120 114
	All Models	15	1-1/4	120 151
	All Models	5	5/8	126 049
	All Models	9	7/8	147 684
	All Models	14	1-1/16	147 685
	All Models	30	1-7/16	147 686
	All Models	1	5/8	149 559
	All Models	6	3/4	147 683
	All Models	10	1-1/4	117 142
	All Models	60	43/50	2258 284
	All Models	7-1/2	7/8	150 866
	All Models	4	5/8	147 682
	All Models	3		445 635
	All Models	2	5/8	148 086
	All Models	10	5/8	142 864
	All Models	20		106 650

CODE	PART NAME AND DESCRIPTION	CYL.	PER CAR	VALIANT LANCER	PLYMOUTH DODGE	CHRYSLER IMPERIAL
<b>8-19-O INSTRUMENT PANEL WIRING</b>						
8-19-2	CONTACT, Ash Receiver Lamp . . . . .		★	*2256 966	*2256 966	*2256 966
8-19-3	WIRING, Instrument Panel . . . . .	6	1	2258 301		
	SP1, SP2, SC1, SC2, SC3 . . . . .		1	----	*2258 033	*2258 897
	SD1, SD2, SY1 . . . . .		1	----	*2258 126	*2257 979
	SD3 . . . . .	8	1	----	2426 145	
	Temperature and Fuel Gauge Feed Cable, SD1, SD2 . . . . .		1	----	1887 103	
8-19-15	BOARD, Printed Circuit, SP1, SP2 . . . . .		1	2258 332	2258 427	
8-19-16	CABLE, Printed Circuit Ground, SP1, SP2 . . . . .		1	----	B2426 995	
8-19-39	TERMINAL, Temperature Gauge Wiring . . . . . No. 1 Post, SY1 . . . . .	6	1	1770 660		
		8	1	----	----	1770 660
8-19-83	SOCKET, HOUSING and CABLE, Ash Receiver Lamp, SC1, SC2, SC3 . . . . .	8	1	----	----	1887 726
		8	1	----	----	2258 297
8-19-87	CONNECTOR, w/CLIP and GASKET, Bulkhead . . . . .		1	2258 497	2258 497	2258 497
<b>8-20-O CIGAR LIGHTER</b>						
8-20-3	FUSE, Rear Console Cigar Lighter Heat Limiter, SP2-P, SD2-P, SC2 . . . . .	8	1	----	1887 222	1887 222
8-20-4	FUSE and FUSE HOLDER, Console Cigar Lighter Feed Cable, SD2-P . . . . .	8	1	----	1971 742	
		8	1	----	----	1885 608

★ Indicates use as required. Numerals in parentheses ( ) refer to notes. Printed in U.S.A.  
 □ Indicates parts not listed in any previous parts book. Prices and specifications subject to change without notice.  
 \* Indicates change or addition. March 8, 1963 Supersedes May 1, 1962.

# 1962 PASSENGER CAR PARTS CATALOG

ELECTRICAL

CODE	PART NAME AND DESCRIPTION	C Y L.	PER CAR	VALIANT LANCER	PLYMOUTH DODGE	CHRYSLER IMPERIAL
<b>8-20-0 CIGAR LIGHTER - Cont'd</b>						
8-20-8	KNOB, Instrument Panel Cigar Lighter, SP1, SP2, SD1, SD2 . . . . .	8	1	2076 474	2290 188	2290 188
	SD3 . . . . .	8	1	----	2257 480	
	Rear Console, SP2-P, SD2-P, SC2 . . . . .	8	1	----	2290 188	2290 188
	Front Seat Back, SC3 . . . . .	8	1	----	----	2290 188
	Rear Quarter Arm Rest, Cv. Cp. and Sp. Cl. Cp., SY1 . . . . .	8	2	----	----	2290 188
	Rear Door Arm Rest Cigar Lighter, Sp. 4 D., SY1 . . . . .	8	2	----	----	2290 188
8-20-9	ELEMENT, Instrument Panel Cigar Lighter Heat .	8	1	1692 678	1692 678	1692 678
	Rear Console, SP2-P, SD2-P, SC2 . . . . .	8	1	----	1692 678	1692 678
	Front Seat Back Cigar Lighter Heat, SC3 . . . . .	8	1	----	----	1692 678
	Rear Door Arm Rest Cigar Lighter Heat, Sp. 4 D., SY1 . . . . .	8	2	----	----	1692 678
	Rear Quarter Panel Arm Rest Cigar Lighter Heat, Cv. Cp., and Sp. Cl. Cp., SY1 . . . . .	8	2	----	----	1692 678
8-20-10	SHELL and CLAMP, Instrument Panel Cigar Lighter . . . . .	8	1	2096 599	2096 599	2096 599
	Console, SP2-P, SD2-P, SC2 . . . . .	8	1	----	2198 192	2198 192
	Front Seat Back Cigar Lighter, SC3 . . . . .	8	1	----	----	2096 599
	Rear Quarter Panel Arm Rest Cigar Lighter, Cv. Cp. and Sp. 4 D., SY1 . . . . .	8	2	----	----	2096 599
	Rear Door Arm Rest Cigar Lighter, Sp. 4 D., SY1 . . . . .	8	2	----	----	2096 599
8-20-16	BEZEL, Instrument Panel Cigar Lighter, SD3 . .	8	1	----	1887 787	
<b>8-21-0 TERMINAL BLOCK</b>						
8-21-1	BLOCK, Instrument Panel Terminal, SD3 . . . . .	8	1	----	1885 637	

## 8-27-0 IGNITION DISTRIBUTOR

NOTE: Use Part No. Stamped on Distributor for Complete Replacement and Ordering Component Parts.

8-27-1	DISTRIBUTOR ASSEMBLIES, Chrysler Built, w/170 cu. in. Eng., w/Std. Trans. . . . .	6	1	2095 974		
	Chrysler Built, w/170 cu. in. Eng., w/Auto. Trans.	6	1	2098 533	----	----
	Chrysler Built, w/225 cu. in. Eng. . . . .	6	1	2095 976	2095 976	
	Chrysler Built, w/Std. Trans., w/318 cu. in. Eng. .	8	1	----	2095 983	
	Chrysler Built, w/Auto. Trans., w/318 cu. in. Eng. .	8	1	----	2095 979	
	Chrysler Built, One 4 Barrel Carburetor, w/318 cubic in. Eng. . . . .	8	1	----	2095 981	
	Double Breaker, One 4 Barrel, SP2 Golden Commando, SP2 Police w/High Performance, SD2-D500, SD2 Police w/High Performance, SC1 Police w/High Performance, SC2 Police w/High Performance . . . . .	8	1	----	2095 832	2095 832
	Double Breaker, Two-4 Barrel Carburetor, w/413 cu. in. Eng., SP2, SD2 . . . . .	8	1	----	E2098 725	
	Chrysler Built, Single Breaker, One 2 Barrel, SD3, SC2 w/o High Performance . . . . .	8	1	----	2095 836	2095 836
	Double Breaker, Two-4 Barrel, SC2-300H w/High Performance . . . . .	8	1	----	----	2098 495
	Chrysler Built, Single Breaker, One 4 Barrel, SC2 Power Pack, SC3, SY1 . . . . .	8	1	----	----	2095 987
8-27-61	CAP, ROTOR and CABLE PACKAGE, Distributor	6	1	E2448 273	E2448 273	
8-27-259	SPACER, Distributor Cam . . . . .		1	1889 996	1889 996	1889 996
8-27-296	WICK, Distributor Cam Sleeve . . . . .		1	643 899	643 899	643 899
8-27-320	TUBE, Carburetor to Distributor Vacuum Control .		1	2264 962	2264 962	2264 962

★ Indicates use as required. Numerals in parentheses ( ) refer to notes. Printed in U.S.A.  
 E Indicates parts not listed in any previous parts book. Prices and specifications subject to change without notice.  
 March 8, 1963 Supersedes May 1, 1962. Page 8-28 \* Indicates change or addition.



CODE	PART NAME AND DESCRIPTION	C Y L.	PER CAR	VALIANT LANCER	PLYMOUTH DODGE	CHRYSLER IMPERIAL
------	---------------------------	--------------	------------	-------------------	-------------------	----------------------

**8-27-0 IGNITION DISTRIBUTOR - Cont'd**

FOR MODEL APPLICATION SEE CODE 8-27-1

CODE	REMARKS	DISTRIBUTOR ASSEMBLIES				
		2095 832 IBS-4006G	2095 836	2095 841 IBS-4010B	2095 974	2095 976
<b>DISTRIBUTOR COMPONENT PARTS</b>						
8-27-4	GASKET, Distributor . . . . .	1326 836	1326 836	1326 836	2095 630	2095 630
8-27-26	CLAMP . . . . .	1947 613	1947 613	----	----	----
8-27-27	SCREW and WASHER, Clamp . . . . .	6022 185	6022 185	----	----	----
8-27-71	CAP . . . . .	2084 654	1838 514	1658 534	*2098 765	*2098 765
8-27-76	SPRING, Cap Attaching . . . . .	----	1838 508	----	1838 508	1838 508
8-27-77	SPRING and HINGE PACKAGE, Cap Clamp . . . . .	1879 606	----	1879 606	----	----
8-27-85	CONTACT and SPRING PACKAGE, Cap Plunger . . . . .	2084 655	----	1879 594	----	----
8-27-100	OILER . . . . .	953 717	----	953 717		
8-27-133	BEARING and THRUST WASHER PACKAGE, Drive Shaft . . . . .	1879 596	2275 229	1879 596	2275 228	2275 228
8-27-137	COLLAR and PIN PACKAGE, Drive Shaft . . . . .	----	2084 448	----	----	----
8-27-138	PLATE, Breaker . . . . .	2299 321	2095 922	2299 321	2095 922	2095 922
8-27-158	CONTACT SET . . . . .	2299 322	2098 244	2299 322	2098 244	2098 244
8-27-190	CONDENSER . . . . .	1818 757	2098 058	1818 757	2098 058	2098 058
8-27-205	LEAD, Primary . . . . .	1383 958	2095 873	1383 958	2095 508	2095 508
8-27-208	BREAKER and GROUND LEAD PACKAGE	2299 320	----	2299 320	----	----
8-27-218	TERMINAL and STUD PACKAGE . . . . .	1881 751	----	1881 751	----	----
8-27-250	SHAFT, GOVERNOR and CAM . . . . .	----	2098 189	----	2098 173	2098 208
8-27-278	WEIGHT PACKAGE, Governor . . . . .	1881 746	1881 955	1881 746	1881 945	1881 945
8-27-279	SPRING SET, Governor Weight . . . . .	2275 227	2298 765	2084 866	2298 758	2298 759
8-27-292	CAM and STOP PLATE . . . . .	----	2098 190	----	2098 175	2095 274
8-27-297	FELT DISC and SNAP RING PACKAGE, Cam Sleeve . . . . .	1879 607	1879 607	1879 607	1879 607	1879 607
8-27-300	ROTOR . . . . .	1658 535	1838 516	1658 535	*2098 770	*2098 770
8-27-308	CHAMBER PACKAGE, Vacuum . . . . . CONTROL, Vacuum . . . . .	2084 857 ----	----	2084 868 ----	----	----
8-27-315	PLUG and GASKET PACKAGE, Vacuum Chamber . . . . .	2299 319	----	2299 319	----	----

★ Indicates use as required.

Numerals in parentheses ( ) refer to notes.

Printed in U.S.A.

☐ Indicates parts not listed in any previous parts book.

Prices and specifications subject to change without notice.

\* Indicates change or addition.

March 8, 1963 Supersedes May 1, 1962.

**8-27-0 IGNITION DISTRIBUTOR - Cont'd**

FOR MODEL APPLICATION SEE CODE 8-27-1

CODE	REMARKS	DISTRIBUTOR ASSEMBLIES				
		2095 832 IBS-4006G	2095 836	2095 841 IBS-4010B	2095 974	2095 976
<b>DISTRIBUTOR COMPONENT PARTS - Cont'd</b>						
8-27-316	SPRING and WASHER PACKAGE, Vacuum Chamber . . . . .	1881 750	----	1881 766	----	----
8-27-352	GEAR and PIN PACKAGE, Drive . . . . .	----	----	----	2084 653	2084 653

FOR MODEL APPLICATION SEE CODE 8-27-1

CODE	REMARKS	DISTRIBUTOR ASSEMBLIES			
		2095 979	2095 981	2095 983	2095 987
<b>DISTRIBUTOR COMPONENT PARTS</b>					
8-27-4	GASKET, Distributor . . . . .	1326 836	1326 836	1326 836	1326 836
8-27-26	CLAMP . . . . .	*1947 612	*1947 612	*1947 612	*1947 613
8-27-27	SCREW and WASHER, Clamp . . . . .	1675 958	1675 958	1675 958	*6022 185
8-27-71	CAP . . . . .	1838 514	1838 514	1838 514	1838 514
8-27-76	SPRING, Cap Attaching . . . . .	1838 508	1838 508	1838 508	1838 508
8-27-100	OILER . . . . .	953 717	953 717	953 717	----
8-27-133	BEARING and THRUST WASHER PACKAGE, Drive Shaft . . . . .	2275 229	2275 229	2275 229	2275 229
8-27-137	COLLAR and PIN PACKAGE, Drive Shaft . . . . .	2084 448	2084 448	2084 448	2084 448
8-27-138	PLATE, Breaker . . . . .	2095 922	2095 922	2095 922	2095 922
8-27-158	CONTACT SET . . . . .	2098 244	2098 244	2098 244	2098 244
8-27-190	CONDENSER . . . . .	2098 058	2098 058	2098 058	2098 058
8-27-205	LEAD, Primary . . . . .	2095 873	2095 873	2095 873	2095 873
8-27-250	SHAFT, GOVERNOR and CAM . . . . .	1889 683	1889 684	2095 742	2095 648
8-27-278	WEIGHT PACKAGE, Governor . . . . .	1881 945	1881 945	1881 945	1881 955
8-27-279	SPRING SET, Governor Weight . . . . .	1881 946	1881 949	2240 747	1881 956
8-27-292	CAM and STOP PLATE . . . . .	1889 320	1889 715	2095 741	1889 709
8-27-297	FELT DISC and SNAP RING PACKAGE, Cam Sleeve	1879 607	1879 607	1879 607	1879 607
8-27-300	ROTOR . . . . .	1838 516	1838 516	1838 516	1838 516
8-27-308	CONTROL, Vacuum . . . . .	2098 184	2098 203	2098 298	2098 197

★ Indicates use as required.  
 □ Indicates parts not listed in any previous parts book.  
 May 1, 1962 Supersedes Nov. 30, 1961.

Numerals in parentheses ( ) refer to notes.

Printed in U.S.A.

Prices and specifications subject to change without notice.

\* Indicates change or addition.

**8-27-0 IGNITION DISTRIBUTOR - Cont'd**

FOR MODEL APPLICATION SEE CODE 8-27-1

CODE	REMARKS	DISTRIBUTOR ASSEMBLIES		
		*2098 495 IBS-4011AS	2098 533	*2098 725 IBB-4202S
<b>DISTRIBUTOR COMPONENT PARTS - Cont'd</b>				
8-27-4	"O" RING, Distributor Mounting . . . . .	1326 836	2095 630	*1326 836
8-27-11	GEAR and PIN PACKAGE, Tachometer Drive . . . . .	2084 869	----	----
8-27-18	FOLLOWER GEAR PACKAGE, Tachometer . . . . .	2084 870	----	----
8-27-26	CLAMP . . . . .	*1947 613	----	*1947 613
8-27-27	SCREW and WASHER . . . . .	*6022 185	----	*6022 185
8-27-71	CAP . . . . .	2084 654	*2098 765	*2084 654
8-27-76	SPRING, Cap Attaching . . . . .	----	1838 508	----
8-27-77	SPRING and HINGE PACKAGE, Cap Clamp . . . . .	1879 606	----	*2084 303
8-27-85	CONTACT and SPRING PACKAGE, Cap Plunger. . . . .	2084 655	----	*2084 655
8-27-100	CUP, Grease . . . . .	1879 391	----	* 953 717
8-27-114	BEARING, Ball . . . . .	623 207	----	----
8-27-133	BEARING and THRUST WASHER PACKAGE, Drive Shaft . . . . .	2084 867	2275 228	*1879 596
8-27-138	PLATE, Breaker . . . . .	2299 321	2095 922	*2421 848
8-27-158	CONTACT SET . . . . .	2421 174	2098 244	*2421 849
8-27-190	CONDENSER PACKAGE . . . . .	1818 757	2098 058	*1818 757
8-27-205	LEAD, Primary. . . . .	1383 958	2095 508	*2448 252
8-27-208	BREAKER and GROUND LEAD PACKAGE . . . . .	2299 320	----	----
8-27-218	TERMINAL and STUD PACKAGE . . . . .	1881 751	----	----
8-27-250	SHAFT, GOVERNOR and CAM . . . . .	----	2098 519	----
	SHAFT, Drive . . . . .	----	----	*2448 251
8-27-278	WEIGHT PACKAGE, Governor . . . . .	1881 746	1881 945	*1881 746
8-27-279	SPRING SET, Governor Weight . . . . .	2084 866	2421 473	*2448 250
8-27-292	CAM and STOP PLATE . . . . .	----	2098 175	*2448 805
8-27-297	FELT DISC and SNAP RING PACKAGE, Cam Sleeve . . . . .	1879 607	1879 607	*1879 607
8-27-300	ROTOR . . . . .	1658 535	*2098 770	*1658 535
8-27-308	VACUUM CHAMBER PACKAGE . . . . .	2084 868	----	----
	CONTROL, Vacuum . . . . .	----	2098 177	----
8-27-315	PLUG and GASKET PACKAGE, Vacuum Chamber . . . . .	2299 319	----	----
8-27-316	SPRING and WASHER PACKAGE, Vacuum Chamber. . . . .	1881 766	----	----
8-27-352	GEAR and PIN PACKAGE, Drive . . . . .	----	2084 653	----

★ Indicates use as required.

Numerals in parentheses ( ) refer to notes.

Printed in U.S.A.

☐ Indicates parts not listed in any previous parts book.

Prices and specifications subject to change without notice.

\* Indicates change or addition.

# 1962 PASSENGER CAR PARTS CATALOG

CODE	PART NAME AND DESCRIPTION	CYL.	PER CAR	VALIANT LANCER	PLYMOUTH DODGE	CHRYSLER IMPERIAL
------	---------------------------	------	---------	----------------	----------------	-------------------

## 8-28-0 GENERATOR OR ALTERNATOR

- NOTE:** For Component Parts of Generators or Alternators see Part Type Code 8-29-0. Where Component Parts of a listed Generator or Alternator are not shown please order by description. Production Assemblies are for Identification purposes only. Order Service Generators or Alternators.
- NOTE:** Higher Ampere Leece-Neville Alternators and Alternator Regulators are used on some 1962 Vehicles. Mopar Parts Plants do not stock Complete Replacement Assemblies or Repair Parts for Leece-Neville Units. When Complete Alternator or Alternator Regulator Assemblies or Repair Parts are required, they should be ordered by Description Direct from the nearest Leece-Neville distributor or Leece-Neville, 1374 E. 51st Street, Cleveland 3, Ohio. Attaching Parts such as Brackets, Straps and Belts are available through your usual MoPar Parts Source.
- NOTE:** Part Numbers 2098 265, 2098 275 and 2098 320 were manufactured with 2 types of Alternators which are interchangeable as assemblies. Certain internal components are not interchangeable, therefore when specifying components for the above Alternators, w/PULLEY it is necessary to first identify the Alternators by the number stamped on same which are shown in the above column as Identification No. stamped on Alternator.
- NOTE:** Alternator 2098 265 includes No. 2095 430 Single Groove Pulley. If Double Groove Pulley is required change Pulley to No. 2095 662.
- NOTE:** Alternator 2098 320 includes No. 2095 059 Double Groove Pulley. When using on cars equipped with Single Groove Pulley it is not necessary to change Pulley to Single Groove.

**IMPORTANT:** When specifying Alternators or Components See Note:

CODE	REMARKS	Alternator w/Pulley	Amps		Pulley No.	Identification No. Stamped on Alternator
8-28-3	SL1, SV1 . . . . .	*2098 275	30	S	*2095 430	2098 270 or 2098 530 2098 260
	SP1, SP2, SD1, SD2, SD3, SC1, SC2, SC3, SY1	*2098 265	35	S	*2095 430	or 2098 525 2095 300
	SV1, SL1, SP1, SP2, SD1, SD2, SD3, SC1, SC2, SC3, Heavy Duty, Police and Taxi	*2098 850	40	S	*2095 430	or 2098 535 2095 300
	SP2, SD2, w/361 and 383 cu. in. Eng., SD3, SC1, SC2, SC3, SY1, w/Air Conditioning, w/3" Pulley . . . . .	*2098 850	40	D	*2095 059	or 2098 535 2098 260
	SP2, SD2, w/413 cu.in.Eng., w/3-1/2" Pulley	*2098 265	35	D	*2095 662	or 2098 525

**NOTE:** Letters "S" and "D" in Pulley Margin Represent Single Groove and Double Groove.

CODE	PART NAME AND DESCRIPTION	CYL.	PER CAR	VALIANT LANCER	PLYMOUTH DODGE	CHRYSLER IMPERIAL
8-28-14	SPACER, Alternator Adjusting Strap, to Water Pump Housing, High Performance, w/o Air Conditioning . . . . .	8	1	----	2206 450	2206 450
8-28-15	STRAP, Alternator Adjusting . . . . .	6	1	2202 767	2202 767	
	w/o High Performance . . . . .	8	1	----	2202 942	
	w/o High Performance, w/o Air Conditioning, used w/Leece-Neville Alternator . . . . .	8	1	----	2264 518	
	w/413 cu. in. Eng., SP2, SD2 . . . . .	8	1	----	2402 297	
	w/High Performance, w/o Air Conditioning, SP2, SD2 . . . . .	8	1	----	*2206 446	
	w/High Performance, w/Air Conditioning . . . . .	8	1	----	2129 060	

★ Indicates use as required. Numerals in parentheses ( ) refer to notes. Printed in U.S.A.  
 □ Indicates parts not listed in any previous parts book. Prices and specifications subject to change without notice.  
 March 8, 1963 Supersedes May 1, 1962. \* Indicates change or addition.

CODE	PART NAME AND DESCRIPTION	CYL	PER CAR	VALIANT LANCER	PLYMOUTH DODGE	CHRYSLER IMPERIAL
<b>8-28-0 GENERATOR OR ALTERNATOR - Cont'd</b>						
8-28-15	STRAP - Cont'd					
	w/High Performance, w/o Air Conditioning, used w/Leece-Neville Alternator . . . . .	8	1	----	2206 348	
	w/Air Conditioning, Field Installation, Model G, SP2 except 318 cubic in. Eng., SD2 except 318 cubic in. Eng. . . . .	8	1	----	1999 184	1999 184
	w/o Air Conditioning, w/Leece-Neville Alternator, SC1, SC2 . . . . .	8	1	----	----	2206 348
	w/o Air Conditioning, SD3, SC1, SC2 . . . . .	8	1	----	2206 446	2206 446
	w/Air Conditioning, SD3 . . . . .	8	1	----	2129 060	2129 060
	w/o Air Conditioning, SC2 High Performance and w/Power Pack, SC3, SY1 . . . . .	8	1	----	----	2206 447
8-28-36	BRACKET, Alternator and Coil Mounting . . . . .	6	1	2264 880	2264 880	
	w/Leece-Neville Alternator, w/Dual Belt . . . . .	6	1	2264 459	2264 459	
	w/o High Performance . . . . .	8	1	----	2202 940	
	w/o High Performance, w/o Air Conditioning, w/Leece-Neville Alternator . . . . .	8	1	----	2264 523	
	w/High Performance, w/o Air Conditioning SP2, SD2 . . . . .	8	1	----	2206 445	
	w/High Performance, w/Air Conditioning . . . . .	8	1	----	2129 154	
	Front, w/High Performance, w/o Air Conditioning, w/Leece-Neville Alternator . . . . .	8	1	----	2206 346	
	w/Spring Anchor, High Performance, w/o Air Conditioning, w/Leece-Neville Alternator . . . . .	8	1	----	2206 347	
	w/Air Conditioning, Field Installation, Model G, SP2 except 318 cubic in. Eng., SD2 except 318 cubic in. Eng. . . . .	8	1	----	2129 156	2129 156
	Front, w/o Air Conditioning, w/Leece-Neville Alternator, SC1, SC2 . . . . .	8	1	----	----	2206 346
	w/Spring Anchor, w/o Air Conditioning, w/Leece-Neville Alternator, SC1, SC2 . . . . .	8	1	----	----	2206 347
	w/o Air Conditioning, SD3 . . . . .	8	1	----	2206 445	2206 445
	w/Air Conditioning, SD3 . . . . .	8	1	----	2129 154	2129 154
8-28-74	REGULATOR, Alternator Voltage . . . . .		1	2098 300	2098 300	2098 300
8-28-88	SCREW and CLAMP, Alternator Regulator Terminal, w/Leece-Neville Alternator, SC1 . . . . .		4	1779 986	1779 986	1779 986
8-28-292	SPACER, Alternator to Cylinder Head, w/o Air Conditioning, SP2 High Performance, SD2 High Performance, SD3 . . . . .	8	1	----	2206 448	2206 448
	SPACER, Alternator, w/o Air Conditioning, SP2 High Performance, SD2 High Performance, SD3 . . . . .	8	1	----	2206 449	2206 449

**8-29-0 GENERATOR OR ALTERNATOR COMPONENT PARTS**

FOR MODEL APPLICATION SEE CODE 8-28-3

CODE	REMARKS			
	Service Alternators, w/PULLEY Identification number on Alternator	*2098 265	*2098 275	*2098 850
		*2098 260	*2098 270	*2095 300
		or	or	or
		*2098 525	*2098 530	*2098 535
<b>ALTERNATOR COMPONENT PARTS</b>				
8-29-17	BRUSH, WASHER and TERMINAL PACKAGE . . . . .	*2084 673	*2084 673	*2084 673
8-29-42	HOLDER, Brush . . . . .	*2095 038	*2095 038	*2095 038

★ Indicates use as required. Numerals in parentheses ( ) refer to notes. Printed in U.S.A.  
 ☐ Indicates parts not listed in any previous parts book. Prices and specifications subject to change without notice.  
 \* Indicates change or addition. March 8, 1963 Supersedes May 1, 1962.

**8-29-O GENERATOR OR ALTERNATOR COMPONENT PARTS - Cont'd**

FOR MODEL APPLICATION SEE CODE 8-28-3

CODE	REMARKS			
	Service Alternator, w/PULLEY Identification Number on Alternator	*2098 265 *2098 260 or *2098 525	*2098 275 *2098 270 or *2098 530	*2098 850 *2095 300 or *2098 535
<b>ALTERNATOR COMPONENT PARTS - Cont'd</b>				
8-29-97	ROTOR (use w/Alternators identified as 2098 260, 2098 270 and 2095 300) . . . . .	*2098 231	*2098 232	*2095 013
	ROTOR (use w/Alternators identified as 2098 525, 2098 530 and 2098 535). . . . .	*2098 511	*2098 516	*2098 511
8-29-98	STATOR. . . . .	*2095 427	*2095 427	*2095 427
8-29-99	SLIP RING, for use w/Knurlled Shaft (use w/Alternator identified as 2098 260, 2098 270 and 2095 300) . . . . .	*2098 278	*2098 278	*2098 278
	SLIP RING, for use w/Ground Shaft (use w/Alternator identified as 2098 260, 2098 270 and 2095 300) . . . . .	-----	-----	*2098 279
	RETAINER, WASHER and SLIP RING PACKAGE, Rotor Grease (use w/Alternator identified as 2098 525, 2098 530 and 2098 535). . . . .	*2421 804	*2421 804	*2421 804
8-29-129	CAPACITOR and INSULATOR PACKAGE . . . . .	*2421 137	*2421 137	*2421 137
8-29-130	SCREW, Capacitor Ground . . . . .	*6022 381	*6022 381	*6022 381
8-29-131	RECTIFIER, Positive . . . . .	*2098 288	*2098 288	*2098 288
	RECTIFIER, Negative . . . . .	*2098 287	*2098 287	*2098 287
8-29-132	SHIELD, Rectifier End (use w/Alternator identified as 2098 260, 2098 270 and 2095 300) . . . . .	*2095 339	*2095 339	*2095 339
	SHIELD, Rectifier End (use w/Alternator identified as 2098 525, 2098 530 and 2098 535) . . . . .	*2098 646	*2098 646	*2098 646
8-29-133	BEARING, Rectifier End Shield (use w/Alternator identified as 2098 260, 2098 270 and 2095 300) . . . . .	*2095 037	*2095 037	*2095 037
	BEARING, Rectifier End Shield (use w/Alternator identified as 2098 525, 2098 530 and 2098 535) . . . . .	*2098 512	*2098 512	*2098 512
8-29-134	INSERT, Rectifier End Mounting . . . . .	*2095 052	*2095 052	*2095 052
8-29-135	HEAT SINK, Rectifier . . . . .	*2095 925	*2095 925	*2095 925
8-29-143	CEMENT, Lead Wire, 5 oz. Tube (use w/Alternator identified as 2098 260, 2098 270 and 2095 300) . . . . .	*2299 314	*2299 314	*2299 314
8-29-145	SPACER PACKAGE, Heat Sink . . . . .	*2421 138	*2421 138	*2421 138
8-29-153	SHIELD, Drive End . . . . .	*2095 945	*2095 945	*2095 945
8-29-154	BEARING, Drive End Shield. . . . .	*2098 478	*2098 478	*2098 478
8-29-155	PLATE, Drive End Bearing Retainer. . . . .	*2095 012	*2095 012	*2095 012
8-29-194	SCREW, Field Terminal Mounting. . . . .	*6023 112	*6023 112	*6023 112
8-29-208	SCREW, Frame . . . . .	*2095 004	*2095 004	*2095 004

★ Indicates use as required. Numerals in parentheses ( ) refer to notes. Printed in U.S.A.  
 ☐ Indicates parts not listed in any previous parts book. Prices and specifications subject to change without notice.  
 March 8, 1963 Supersedes May 1, 1962. \* Indicates change or addition.

CODE	PART NAME AND DESCRIPTION	CYL.	PER CAR	VALIANT LANCER	PLYMOUTH DODGE	CHRYSLER IMPERIAL
<b>8-30-O GROMMETS</b>						
8-30-1	GROMMET, Headlamp Wiring, SV1 . . . . .	6	2	2257 299		
	Headlamp Wiring, SL1 . . . . .	6	2	2097 303		
	Wiring Dash Slot, 3/4" thk. . . . .		★	2097 814	2097 814	2097 814
	Speedometer Cable, 3/8" thk. . . . .		★	2097 816	2097 816	2097 816
	Dummy, 3/4" Dash-Slot . . . . .		★	1971 740	1971 740	1971 740
	Main, Dash, w/o Slot, one Channel . . . . .		★	1971 732	1971 732	1971 732
	Main, Dash, w/Slot, one Channel . . . . .		★	1971 731	1971 731	1971 731
	Main, Dash, w/Slot, three Channels . . . . .		★	1971 733	1971 733	1971 733
<b>8-31-O PARKING BRAKE SIGNAL LAMP</b>						
8-31-2	LAMP, Parking Brake Indicator, SP1, SP2, SD1, SD2 . . . . .		1	2298 767	2298 767	
	SD3 . . . . .	8	1	----	2096 526	
8-31-3	FLASHER, Parking Brake Indicator Lamp, SY1 . . . . .	8	1	----	----	1971 896
8-31-10	SWITCH, Parking Brake Indicator Lamp, SP1, SP2, SD1, SD2, SY1 . . . . .		1	2097 279	2097 279	2097 279
	SD3, SC1, SC2, SC3 . . . . .	8	1	----	1971 931	1971 931
8-31-11	BRACKET, Parking Brake Indicator Lamp Switch, SD3, SC1, SC2, SC3 . . . . .	8	1	----	2096 396	2096 396
8-31-16	SOCKET, Parking Brake Indicator Lamp, SD3 . . . . .		1	1314 619	1753 632	1753 632
	w/HOUSING, SD1, SD2 . . . . .		1	----	1880 587	
8-31-18	CONTACT, Parking Brake Indicator Lamp Socket . . . . .		★	*2256 966	*2256 966	*2256 966
<b>8-32-O HORN</b>						
8-32-2	HORN, w/Mounting BRACKET, Right . . . . .	6	1	2298 792		
	Left, w/Mounting BRACKET . . . . .	6	1	2298 791		
	Upper, w/Mounting BRACKET, SP1, SP2, SD1, SD2. Lower, w/Mounting BRACKET, SP1, SP2, SD1, SD2.		1	----	2298 793	
	Right, Auto-Lite, SD3, SC1, SC2 . . . . .	8	1	----	2298 794	
	Left, Auto-Lite, SD3, SC1, SC2 . . . . .	8	1	----	2291 424	2291 424
	Right, w/Mounting BRACKET, Sparton, SC3, SY1 Left, w/Mounting BRACKET, Sparton, SC3, SY1	8	1	----	2291 423	2291 423
	Right, w/Mounting BRACKET, Sparton, SC3, SY1 Left, w/Mounting BRACKET, Sparton, SC3, SY1	8	1	----	----	2291 420
	Left, w/Mounting BRACKET, Sparton, SC3, SY1	8	1	----	----	2291 419
8-32-15	BRACKET, Horn Mounting, Auto-Lite, SP1, SP2, SD1, SD2, SC1, SC2 . . . . .		2	2291 118	2258 517	2197 876
	Auto-Lite, SD3, SC3 . . . . .	8	2	----	2197 876	2197 871
8-32-18	SCREW, Horn and Bracket Mounting . . . . .	6	★	6023 253		
	Radiator Side Yoke . . . . .	2	★	----	6023 253	
	Horn Bracket to Horn Mounting, SC1, SC2, SC3 . . . . .		★	2290 623	2290 623	2290 623
	Mounting to Yoke, SD3, SC1, SC2 . . . . .	8	2	----	6023 253	6023 253
	Mounting to Radiator Cross Bar, SC3 . . . . .	8	2	----	----	6023 253
	Mounting to Radiator Cross Bar, SY1 . . . . .	8	2	----	----	6022 802
<b>8-33-O HORN CONTROLS</b>						
8-33-4	RING, Steering Wheel Horn, SP1-L 4 D., SP1-H-M, SP2-L 4 D., SP2-M-H-P, SD1-H-M, SD2-H-M, SY1 . . . . .		1	*2265 517	*2204 104	*2200 585
	Police Car, SC1 . . . . .		1	----	1738 214	1738 214
	w/ORNAMENT, w/Plastic Wheel, SP1, SP2 . . . . .		1	----	2266 222	
	w/ORNAMENT, w/Plastic Wheel, SD1, SD2 except SD2-P . . . . .		1	----	2260 983	
	w/ORNAMENT, w/Plastic Wheel, SD2-P . . . . .	8	1	----	2266 720	
	w/Rubber Wheel, SD3, SC1, SC2 . . . . .	8	1	----	2200 706	1945 920
	w/Plastic Wheel, SC1, SC2, SC3 . . . . .	8	1	----	----	2265 332

★ Indicates use as required.

Numerals in parentheses ( ) refer to notes.

Printed in U.S.A.

□ Indicates parts not listed in any previous parts book.

Prices and specifications subject to change without notice.

\* Indicates change or addition.

# 1962 PASSENGER CAR PARTS CATALOG

ELECTRICAL

CODE	PART NAME AND DESCRIPTION	CYL	PER CAR	VALIANT LANCER	PLYMOUTH DODGE	CHRYSLER IMPERIAL
<b>8-33-0 HORN CONTROLS - Cont'd</b>						
8-33-5	RETAINER, Horn Button Ornament Cap, Paint, SP1L, SP2L, SD1L, SD2L . . . . .		1	----	2207 888	
	Police Car, SC1 . . . . .		1	----	1673 967	1673 967
	Ring, w/Plastic Wheel, SP1, SP2, SD1, SD2 . . . . .		1	----	2260 511	
	SD3 . . . . .	8	1	----	2200 557	
8-33-6	ORNAMENT, Steering Wheel Horn, SV1 . . . . .	6	1	2266 209		
	SL1 . . . . .	6	1	2266 210		
	Complete, Chrome, w/Rubber Wheel, SP1, SP2 . . . . .		1	----	*2207 883	
	Horn Ring, w/Plastic Wheel, SP1, SP2 . . . . .		1	----	2266 223	
	Horn Ring, Partial, Plastic, SP1, SP2 . . . . .		1	----	*2204 107	
	Horn Ring, Partial, Plastic, SD1, SD2 except SD2-P . . . . .		1	----	*2204 108	
	Complete, Chrome, w/Rubber Wheel, SD1, SD2 . . . . .		1	----	*2207 887	
	Horn Ring, w/Plastic Wheel, SD2-P . . . . .	8	1	----	2266 721	
	SD3, w/o Power Steering . . . . .	8	1	----	2200 716	
	SD3, w/Power Steering . . . . .	8	1	----	2200 717	
	Horn Ring, Complete, SC1 . . . . .	8	1	----	----	2265 503
	Horn Ring, Complete, SC2 . . . . .	8	1	----	----	2265 504
	Horn Ring, Complete, SC3 . . . . .	8	1	----	----	2265 505
8-33-19	BASE, Horn Button Ornament, SV1L, SL1-L . . . . .	6	1	2266 220		
	Horn Ring Mounting, SY1 . . . . .	8	1	----	----	1730 978
8-33-23	SPACER, Steering Wheel Ornament . . . . .	6	1	2401 209		
8-33-39	BUSHING PACKAGE, Horn Ring Spacer . . . . .		1	2240 608	2240 608	2240 608
8-33-40	SCREW, Horn Blowing Ring Spacer Bushing . . . . .		★	1325 906	1325 906	1325 906
8-33-70	"O" RING, Steering Wheel Ornament Retainer . . . . .	6	1	6023 346		
8-33-90	SWITCH, Horn, Complete, SV1L, SL1-L, SP1L, SP2L, SD1L, SD2L . . . . .		1	2076 543	2076 543	
	w/Horn Ring, SV1H-P, SL1H-P, SC1, SC2, SC3 . . . . .		1	1972 391	1972 391	1972 391
	w/Horn Ring, Export, SV1-L, SL1-L . . . . .	6	1	1972 391		
	SD3, SY1 . . . . .	8	1	----	1971 940	1704 689
8-33-118	CONTACT, Turn Signal Switch Horn, SD3 . . . . .	8	1	----	*1604 921	*1604 921
8-33-120	SLEEVE, Horn Contact and Turn Signal Cancelling Switch Actuating, SC1, SC2, SC3 . . . . .	8	1	----	----	2291 440
8-33-121	RING and FEED CABLE, Horn Contact, SY1 . . . . .		1	2258 723	2258 723	2197 079
	SD3, SC1 Police . . . . .	8	1	----	2258 588	2258 588
8-33-164	RELAY, Horn . . . . .		1	2196 312	2196 312	2196 312
<b>8-34-0 HEADLAMP</b>						
8-34-1	HEADLAMP and DOOR PACKAGE, Headlamp, Right, SV1 . . . . .	6	1	2298 787		
	Left, SV1 . . . . .	6	1	2298 788		
	HEADLAMP, Left-Shift, Export, Right, SV1 . . . . .	6	1	2258 760		
	Left, Left-Shift, Export, SV1 . . . . .	6	1	2258 761		
	HEADLAMP PACKAGE, w/o Door, Right, SL1 . . . . .	6	1	2298 789		
	Left, SL1 . . . . .	6	1	2298 790		
	HEADLAMP, Left-Shift, Export, Right, SL1 . . . . .	6	1	2258 504		
	Left, Left-Shift, Export, SL1 . . . . .	6	1	2258 505		
	High-Low Beam, Riteway Shift . . . . .		2	----	2097 316	2097 316
	High-Low Beam, Left-Shift, Export . . . . .		2	----	2097 317	2097 317
	High Beam . . . . .		2	----	2097 319	2097 319

★ Indicates use as required. Numerals in parentheses ( ) refer to notes. Printed in U.S.A.  
 □ Indicates parts not listed in any previous parts book. Prices and specifications subject to change without notice.  
 March 8, 1963 Supersedes May 1, 1962. Page 8-36 \* Indicates change or addition.



CODE	PART NAME AND DESCRIPTION	C Y L.	PER CAR	VALIANT LANCER	PLYMOUTH DODGE	CHRYSLER IMPERIAL
<b>8-34-O HEADLAMP - Cont'd</b>						
8-34-40	DOOR, Headlamp, Bright Finish, Right, SV1-L-H	6	1	2195 558		
	Left, SV1-L-H	6	1	2195 559		
	Right, Black Finish, SV1-P	6	1	2082 120		
	Left, SV1-P	6	1	2082 121		
	Right, Fender Headlamp, SL1-P	6	1	2099 988		
	Left, SL1-P	6	1	2099 989		
	Right, Fender Headlamp, SL1-L-H	6	1	2242 160		
	Left, SL1-L-H	6	1	2242 161		
	Fender, SP1, SP2		2	----	2099 579	
	Right, Radiator Grille, Inner, SP1, SP2		1	----	2099 332	
	Left, Radiator Grille, Inner, SP1, SP2		1	----	2099 333	
	Fender, SD1, SD2		2	----	2099 974	
	Right, Radiator Grille, SD1, SD2		1	----	2099 492	
	Left, Radiator Grille, SD1, SD2		1	----	2099 493	
	Right, Radiator Grille, SD3	8	2	----	*1904 844	
	Left, Radiator Grille, SD3	8	2	----	*1904 845	
	Right, w/INSERT, SC1, SC2, SC3	8	1	----	----	2099 680
	Left, w/INSERT, SC1, SC2, SC3	8	1	----	----	2099 681
	Fender, SY1	8	4	----	----	1904 214
8-34-46	PLATE, Radiator Grille Headlamp Mounting, White, SD3	8	4	----	1904 839	
8-34-62	NUT, Headlamp Door Attaching, SD1, SD2 Headlamp Housing Bracket to Headlamp Plate, SD3	8	4	----	6023 478	
	Headlamp Door Attaching, SC1, SC2, SC3	8	8	----	6022 162	6022 826
8-34-96	SCREW, Headlamp Door to Grille, SL1 Headlamp Door to Grille and Radiator Yoke Upper Panel, SL1	6	2	6023 625		
	Headlamp Door to Headlamp Shell, SL1	6	2	6022 951		
	T/SCREW, Headlamp Door, SV1	6	4	* 179 355		
	SCREW, Bezel to Fender, SP1, SP2	6	6	274 108		
	Headlamp Door Attaching, SD1, SD2, SC1, SC2, SC3	8	8	----	6023 077	
	Headlamp Door Attaching Lower, SD1, SD2		4	----	6022 893	9415 558
	Headlamp Housing to Bracket, SD3		2	----	6024 094	
	Headlamp Door Attaching, SD3	8	6	----	6022 159	
	Headlamp Housing to Headlamp Mounting Plate, SD3	8	12	----	6022 802	
	Headlamp Door Attaching, SC1, SC2, SC3	8	4	----	----	9414 327
	Headlamp Door Attaching, SY1	8	12	----	----	6010 061
	Headlamp Mounting Reinforcement to Fender to Yoke Lower Shield, SY1	8	4	----	----	6022 506
	Headlamp Mounting Reinforcement to Fender Side Panel to Shear Panel Reinforcement, SY1	8	4	----	----	6022 506
	Headlamp Housing to Fender Stabilizer Attaching, SY1	8	2	----	----	6022 506
	Headlamp Housing Stabilizer Reinforcement to Fender to Yoke Lower Shield, SY1	8	4	----	----	6022 506
	Headlamp Housing Stabilizer Reinforcement to Fender Side Panel to Shear Panel Reinforcement, SY1	8	4	----	----	6022 506
8-34-175	BULB, Headlamp Sealed Beam, High Beam		2	1753 435	1753 435	1753 435
	High-Low Beam, Left-Shift, Export		2	1841 775	1841 775	1841 775
	High-Low Beam, Riteway-Shift		2	1753 436	1753 436	1753 436

★ Indicates use as required.

Numerals in parentheses ( ) refer to notes.

Printed in U.S.A.

□ Indicates parts not listed in any previous parts book.

Prices and specifications subject to change without notice.

\* Indicates change or addition.

# 1962 PASSENGER CAR PARTS CATALOG

ELECTRICAL

CODE	PART NAME AND DESCRIPTION	CYL.	PER CAR	VALIANT LANCER	PLYMOUTH DODGE	CHRYSLER IMPERIAL
<b>8-34-O HEADLAMP - Cont'd</b>						
8-34-177	SPRING, Headlamp Bulb Mounting Seat Adjusting .		4	2076 305	1972 972	1972 972
8-34-178	SCREW, Headlamp Bulb Mounting Seat Adjusting . .		8	1658 660	2197 327	2197 327
8-34-180	RING, Headlamp Bulb Retaining . . . . .		4	2076 306	1779 406	1779 406
8-34-300	REINFORCEMENT, Headlamp Mounting, White, Right, SY1 . . . . .	8	1	----	----	1904 286
	Left, White, SY1 . . . . .	8	1	----	----	1904 287
8-34-302	BRACKET, Headlamp Housing to Headlamp Plate, White, Right, SD3 . . . . .	8	1	----	1904 870	
	Left, SD3 . . . . .	8	1	----	1904 871	
8-34-362	HOUSING and SUPPORT, Headlamp Inner, White, SP1, SP2 . . . . .		2	----	2099 798	
	HOUSING, Support and Reinforcement, Headlamp, Inner, White, SP1, SP2 . . . . .		2	----	2276 772	
	HOUSING, Bracket and Reinforcement, Grille Headlamp, White, Right, SD1, SD2 . . . . .		1	----	2276 778	
	Left, White, SD1, SD2 . . . . .		1	----	2276 779	
	HOUSING, Radiator Grille Headlamp, Right, SD3 .	8	1	----	1904 910	
	Left, SD3 . . . . .	8	1	----	1904 911	
	HOUSING, Outboard, Right, SY1 . . . . .	8	1	----	----	1904 208
	Left, SY1 . . . . .	8	1	----	----	1904 209
	HOUSING, Inboard, Right, SY1 . . . . .	8	1	----	----	1904 212
	Left, SY1 . . . . .	8	1	----	----	1904 213
8-34-371	STABILIZER, Headlamp Housing to Fender, Right, SY1 . . . . .	8	1	----	----	1904 216
	Left, SY1 . . . . .	8	1	----	----	1904 217
8-34-372	GASKET, Headlamp Housing Stabilizer, SY1 . . . .	8	2	----	----	1904 220
	Housing Base, SY1 . . . . .	8	4	----	----	1904 218
8-34-374	REINFORCEMENT, Headlamp Housing Stabilizer, White, Right, SY1 . . . . .	8	1	----	----	1904 282
	Left, White, SY1 . . . . .	8	1	----	----	1904 283
<b>8-35-O IGNITION COIL, SWITCH AND LOCK CYLINDER</b>						
8-35-4	COIL, Ignition . . . . .		1	2084 847	2084 847	2084 847
8-35-22	RESISTOR, Ignition Coil Primary . . . . .		1	*2275 590	*2275 590	*2275 590
8-35-41	BRACKET, Ignition Coil Mounting, used w/Leece-Neville Alternator . . . . .	6	1	2203 144	2203 144	
	On Coil . . . . .	6	1	1688 207	1688 207	
	w/318 cu. in. Eng. . . . .	8	1	----	2095 374	
	Except 318 cu. in. Eng. . . . .	8	1	----	1688 207	1688 207
8-35-44	SPACER, Ignition and Starter Switch Mounting, SD3 . . . . .	8	1	----	2198 869	
8-35-59	SWITCH, Starter and Ignition . . . . .		1	2097 628	2097 628	2097 628
8-35-85	BEZEL, Ignition and Starter Switch . . . . .	6	1	2257 878		
	SP1, SP2 . . . . .		1	----	1972 084	
	SD1, SD2 . . . . .		1	----	2256 449	
	SD3, SC1, SC2, SC3 . . . . .	8	1	----	2198 872	2096 317
	RING, Retainer, SY1 . . . . .	8	1	----	----	1971 873
8-35-95	RETAINER, Ignition and Starter Switch, SP1, SP2 .		1	----	1972 077	

★ Indicates use as required. Numerals in parentheses ( ) refer to notes. Printed in U.S.A.  
 E Indicates parts not listed in any previous parts book. Prices and specifications subject to change without notice.  
 March 8, 1963 Supersedes May 1, 1962. Page 8-38 \* Indicates change or addition.

CODE	PART NAME AND DESCRIPTION	C Y L.	PER CAR	VALIANT LANCER	PLYMOUTH DODGE	CHRYSLER IMPERIAL
<b>8-35-0 IGNITION COIL, SWITCH AND LOCK CYLINDER - Cont'd</b>						
8-35-111	CYLINDER PACKAGE, Ignition and Door Lock . . .		1	2161 192	---- --	2161 503
	Taxi . . . . .		1	2162 503	2162 503	
	Except Sub. . . . .		1	---- --	2161 192	
	Ignition, Door and Manual Tailgate Lock, Sub. . .		1	---- --	2162 531	
	Ignition, Door and Manual Tailgate Lock, Sub., Fleet Special, SD1L, SD2L . . . . .		1	---- --	2241 871	
8-35-115	CYLINDER and KEY, Ignition Lock . . . . .		1	2086 047	2086 047	2086 047
<b>8-36-0 IGNITION</b>						
8-36-1	SET, Mopar Ignition Cable, Resistor Type . . . . .	6	1	2275 739	2275 438	
	SET, Mopar Ignition Cable, Resistor Type, w/High Performance, SP2, SD2 . . . . .	8	1	---- --	2279 899	
	SET, Mopar, Ignition Cable, Resistor Type, w/o High Performance, SP2, SD2 . . . . .	8	1	---- --	2084 219	
	SET, Mopar Ignition Cable, Resistor Type, SD3 . .	8	1	---- --	2084 217	2084 217
	SET, Ignition Cable, Resistor Type, Stainless Steel Core, w/413 cu. in. Eng., SP2, SD2 . . .	8	1	---- --	E2421 497	
	PACKAGE, Ignition Cable, Resistor Type, Stainless Steel Core, 45° Elbow, No. 3 and 5 Cable, w/413 cu. in. Eng., SP2, SD2 . . . . .	8	2	---- --	E2421 496	
	PACKAGE, Ignition Cable, Resistor Type, Stainless Steel Core, Straight, except No. 3 and 5 Cable, w/413 cu. in. Eng., SP2, SD2 . . . . .	8	6	---- --	E2421 495	
	PACKAGE, Mopar Ignition Cable, Resistor Type, Nos. 2, 3, 4 Cable . . . . .	6	3	2084 645		
	PACKAGE, Mopar Ignition Cable, Resistor Type, Nos. 2, 3, 4, 6 Cable . . . . .	6	4	---- --	2084 645	
	PACKAGE, Mopar Ignition Cable, Resistor Type, w/o High Performance, SP2, SD2 . . . . .	8	8	---- --	2084 064	
	PACKAGE, Mopar Ignition Cable, Resistor Type, w/High Performance, except No. 3 Cable, SP2, SD2 . . . . .	8	7	---- --	2084 458	
	PACKAGE, Mopar Ignition Cable, Resistor Type, w/High Performance, No. 3 Cable, SP2, SD2 . .	8	1	---- --	2084 456	
	PACKAGE, Mopar Ignition Cable, Resistor Type, No. 1 Cable, used w/Leece-Neville Alternator, SC1, SC2, SC3 . . . . .	8	1	---- --	---- --	2196 335
	PACKAGE, Mopar Ignition Cable, Resistor Type, No. 7 Cable, SC2 w/o High Performance . . . .	8	1	---- --	---- --	2084 064
	PACKAGE, Mopar Ignition Cable, Resistor Type, No. 7 Cable, SC2 w/High Performance . . . . .	8	1	---- --	---- --	2196 335
	PACKAGE, Mopar Ignition Cable, Resistor Type, except No. 2 and 7 Cable, SC2 . . . . .	8	6	---- --	---- --	2084 064
	PACKAGE, Mopar Ignition Cable, Resistor Type, except No. 2 Cable, SD3, SC1, SC3, SY1 . . . .	8	7	---- --	2084 064	2084 064
	PACKAGE, Mopar Ignition Cable, Resistor Type, No. 2 Cable, SD3 . . . . .	8	1	---- --	2084 065	2084 065
8-36-4	BRACKET, Spark Plug Wire, w/o High Performance, SP2, SD2 . . . . .	8	2	---- --	1739 355	
	w/High Performance, Intermediate Front Right, SP2, SD2 . . . . .	8	1	---- --	2268 113	
	w/High Performance, Intermediate Front Left, SP2, SD2 . . . . .	8	1	---- --	2268 122	
	w/High Performance, Front, SP2, SD2 . . . . .	8	2	---- --	2268 112	
	w/High Performance, Left Bank Intermediate, SP2, SD2 . . . . .	8	1	---- --	2161 168	
	Right Bank, SD3 . . . . .	8	2	---- --	1859 804	1859 804
	Left Bank, SD3 . . . . .	8	2	---- --	1859 803	1859 803
	Intermediate, SD3 . . . . .	8	1	---- --	1859 802	1859 802

★ Indicates use as required.

Numerals in parentheses ( ) refer to notes.

Printed in U.S.A.

E Indicates parts not listed in any previous parts book.

Prices and specifications subject to change without notice.

\* Indicates change or addition.

# 1962 PASSENGER CAR PARTS CATALOG

ELECTRICAL

CODE	PART NAME AND DESCRIPTION	C Y L.	PER CAR	VALIANT LANCER	PLYMOUTH DODGE	CHRYSLER IMPERIAL
<b>8-36-O IGNITION - Cont'd</b>						
8-36-14	SEPARATOR, Spark Plug Cable, Right Bank, High Performance . . . . .		1	1841 499	1841 499	1841 499
8-36-49	CABLE PACKAGE, Coil Secondary, w/15" Cable . . . . .		1	2084 427	2084 427	2084 427
	Except 15" Cable . . . . .		1	2084 428	2084 428	2084 428
	CABLE, Coil Secondary, w/413 cu. in. Eng., SP2, SD2 . . . . .	8	1	----	E2098 572	
8-36-83	CABLE, Spark Plug, No. 1 and 6 . . . . .	6	2	*1889 917	*1889 917	
	No. 2 . . . . .	6	1	*2095 823	*2095 823	
	Nos. 3 and 4 . . . . .	6	2	*2095 277	*2095 277	
	No. 5, w/170 cu. in. Eng. . . . .	6	1	*1889 916		
	No. 5, w/225 cu. in. Eng. . . . .	6	1	*2095 823	*2095 823	
8-36-95	TERMINAL, Spark Plug Cable, Distributor End . . . . .		★	1717 314	1717 314	1717 314
8-36-96	NIPPLE, Coil Secondary Cable, Coil End . . . . .		1	2095 768	2095 768	2095 768
	Distributor End . . . . .		1	2095 766	2095 766	2095 766
	Spark Plug . . . . .		★	2095 766	2095 766	2095 766
8-36-114	PLUG, Spark, Champion N-12Y . . . . .	6	6	2098 360	2098 360	
	Champion J-9Y, High Performance, Police, SC1 . . . . .	8	8	----	2098 334	2098 334
	Champion J-9Y, High Performance, SC2 . . . . .	8	8	----	----	2098 334
	Champion J-12Y, Domestic . . . . .	8	8	----	1889 524	1889 524
	Champion J-18Y, Export . . . . .	8	8	----	1889 525	1889 525
	Champion J-2J, w/413 cu. in. Eng., SP2, SD2 . . . . .	8	8	----	E2098 577	
8-36-117	COVER, Spark Plug . . . . .	6	6	1889 921	1889 921	
		8	8	----	1889 517	1889 517
8-36-124	SHIELD, Spark Plug Heat, High Performance, Right . . . . .	8	1	----	2268 647	
	Left, High Performance . . . . .	8	1	----	2206 006	
	SD3 . . . . .	8	2	----	1821 394	1821 394
8-36-136	TUBE, Spark Plug . . . . .	6	6	2121 245	2121 245	
8-36-137	SEAL, Spark Plug Tube . . . . .	6	6	1947 708	1947 708	
<b>8-37-O INSTRUMENT PANEL INSTRUMENTS</b>						
8-37-1	AMMETER, SL1, SD1, SD2, SY1 . . . . .		1	2257 921	2258 242	2197 223
	SV1, SD3, SC1, SC2, SC3 . . . . .		1	2256 350	2257 652	2256 203
	SP1, SP2 . . . . .		1	----	2257 209	
	100A . . . . .		1	----	2290 425	
	60A, SD1, SD2 . . . . .		1	----	2258 261	
	60A, SP1, SP2, SC1, SC2, SC3 . . . . .		1	----	2290 329	2291 303
8-37-2	LIMITER, Voltage, SP1, SP2 . . . . .		1	----	*2258 413	
	SD1, SD2 . . . . .		1	----	2209 216	
8-37-10	SPACER, Ammeter Mounting . . . . .	6	2	2257 930		
8-37-15	LAMP, Windshield Wiper Switch Title, SY1 . . . . .	8	1	----	----	2198 638
	Headlamp and Instrument Lamp Switch Title, SY1 . . . . .	8	1	----	----	2198 639
	Ignition Switch Title, SY1 . . . . .	8	1	----	----	2198 641
	Power Antenna Switch Title, w/o Auto. Pilot, SY1 . . . . .	8	1	----	----	2198 640
	Power Antenna Switch Title, w/Auto. Pilot, SY1 . . . . .	8	1	----	----	2257 272
8-37-16	LENS, Power Antenna Switch Title Lamp, SY1 . . . . .	8	1	----	----	2198 652
	Auto. Pilot Control Title Lamp, SY1 . . . . .	8	1	----	----	2198 652
	LENS and OVERLAY, Auto. Pilot Title Lamp, SY1 . . . . .	8	1	----	----	2257 273
	Switch Title Lamp, SY1 . . . . .	8	1	----	----	2198 652

★ Indicates use as required. Numerals in parentheses ( ) refer to notes. Printed in U.S.A.  
 □ Indicates parts not listed in any previous parts book. Prices and specifications subject to change without notice.  
 March 8, 1963 Supersedes May 1, 1962. Page 8-40 \* Indicates change or addition.

CODE	PART NAME AND DESCRIPTION	CYL.	PER CAR	VALIANT LANCER	PLYMOUTH DODGE	CHRYSLER IMPERIAL
<b>8-37-O INSTRUMENT PANEL INSTRUMENTS - Cont'd</b>						
8-37-17	POWER SUPPLY, Electro Luminescent, SC1, SC2, SC3 . . . . .	8	1	----	----	2196 314
	SY1 . . . . .	8	1	----	----	2240 544
8-37-20	BEZEL, Headlamp and Instrument Lamp Switch Title Lamp Lens, SY1 . . . . .	8	1	----	----	2197 599
	Dummy Title Power Antenna Switch Title Lamp Lens, SY1 . . . . .	8	1	----	----	2197 599
	Windshield Wiper Switch Title Lamp Lens, SY1 . . . . .	8	1	----	----	2197 599
	Ignition Switch Title Lamp Lens, SY1 . . . . .	8	1	----	----	2197 600
	Auto. Pilot Control Title Lens, SY1 . . . . .	8	1	----	----	2197 600
	Windshield Wiper Title Lamp, SY1 . . . . .	8	1	----	----	1887 784
8-37-21	RETAINER, Switch Title Lamp, SY1 . . . . .	8	4	----	----	2197 449
8-37-85	LENS, Oil Indicator, SP1, SP2 . . . . .	8	1	----	E2257 232	
8-37-88	SOCKET, Low Oil Pressure Indicator Lamp, SD1, SD2, SD3 . . . . .		1	1753 632	*1753 632	
	Oil Warning Lamp, SP1, SP2 . . . . .		1	----	2257 440	
	Instrument Push Button Title Illuminated, SD1, SD2 . . . . .		2	----	2097 003	
	Instrument Panel Gauge Illuminated, SD1, SD2 . . . . .		3	----	2097 003	
8-37-90	BEZEL, Speedometer and Instrument Controls, SV1 . . . . .	6	1	2258 538		
	SL1 . . . . .	6	1	2258 543		
	Instrument Cluster, SD1, SD2 . . . . .		1	----	2258 493	
	w/Std. Trans., SP1, SP2 . . . . .		1	----	2257 376	
	w/Auto. Trans., SP1, SP2 . . . . .		1	----	2257 091	
	Switch Mounting, SC1, SC2, SC3 . . . . .	8	1	----	----	1971 519
8-37-93	CONTACT, Oil Warning Lamp Socket . . . . .		★	*2256 966	*2256 966	
8-37-95	HOUSING, Instrument Cluster, SD3 . . . . .	8	1	----	2257 651	
8-37-98	MASK and SEAL, Speedometer and Instrument Cluster, SC1, SC2, SC3 . . . . .	8	1	----	----	2299 339
8-37-136	GAUGE, Temperature, SL1, SP1, SP2, SC1, SC2, SC3 . . . . .		1	2257 923	2257 213	2257 660
	SV1, SD1, SD2, SY1 . . . . .		1	2256 351	2258 241	2291 553
	SD3 . . . . .	8	1	----	2197 060	
8-37-155	SENDING UNIT, Temperature Gauge, King-Seeley and Auto-Lite . . . . .		1	2240 744	2240 744	2240 744
	Stewart Warner . . . . .		1	2256 302	2256 302	2256 302
8-37-162	LENS, Instrument Cluster, w/o Clock, SD3 . . . . .	8	1	----	2257 645	
	w/Clock, SD3 . . . . .	8	1	----	2197 052	
8-37-177	HOUSING and LENS PACKAGE, Instrument Cluster, SC1, SC2, SC3 . . . . .	8	1	----	----	2084 072
8-37-178	HOUSING, Instrument Panel Instruments SP1, SP2, White . . . . .		1	----	2162 599	
	SD1, SD2, White . . . . .		1	----	2162 602	
	Instrument Panel Instrument Gauges, White, SD3 . . . . .	8	1	----	2080 705	
	Instrument Panel Instrument, Upper, White, SD3 . . . . .	8	1	----	2080 702	
	Instrument Panel Instrument, Lower, White, SD3 . . . . .	8	1	----	2080 703	
	Lower, SY1 . . . . .	8	1	----	----	2161 573
	Upper, SY1 . . . . .	8	1	----	----	2161 650
8-37-190	PLATE, Instrument Cluster, SP1, SP2 . . . . .		1	----	2258 053	
	SD1, SD2 . . . . .		1	----	2258 582	

★ Indicates use as required.

Numerals in parentheses ( ) refer to notes.

Printed in U.S.A.

☐ Indicates parts not listed in any previous parts book.

Prices and specifications subject to change without notice.

\* Indicates change or addition.

March 8, 1963 Supersedes May 1, 1962.

# 1962 PASSENGER CAR PARTS CATALOG

ELECTRICAL

CODE	PART NAME AND DESCRIPTION	C Y L.	PER CAR	VALIANT LANCER	PLYMOUTH DODGE	CHRYSLER IMPERIAL
<b>8-37-O INSTRUMENT PANEL INSTRUMENTS - Cont'd</b>						
8-37-200	SCREW, Speedometer and Instrument Cluster Lens Mounting, SC1, SC2, SC3 . . . . .	8	6	----	----	1972 757
	Instrument Gauge Mounting, SC1, SC2, SC3 . . . . .	8	8	----	----	1972 757
8-37-275	GAUGE, Fuel, SL1, SD3, SC1, SC2, SC3 . . . . .		1	2257 926	2197 059	2258 137
	SV1, SD1, SD2, SY1 . . . . .		1	2256 348	2258 240	2197 225
	SP1, SP2 . . . . .		1	----	2257 205	
8-37-316	GAUGE, Oil, SC1, SC2, SC3 . . . . .	8	1	----	----	2291 302
	SY1 . . . . .	8	1	----	----	2197 222
8-37-317	SENDING UNIT, Oil Pressure . . . . .	8	1	----	----	1972 241
8-37-371	CLUSTER, Speedometer and Instrument, Partial, Mile, SY1 . . . . .	8	1	----	----	2275 243
	Kilo, SY1 . . . . .	8	1	----	----	2275 244
8-37-372	SPEEDOMETER, Mile, SL1, SP1, SP2 . . . . .		1	2291 234	2257 085	
	Kilo, SL1, SP1, SP2 . . . . .		1	2291 235	2256 334	
	Mile, SV1, SD1, SD2, SC1, SC2, SC3 . . . . .		1	2291 232	2258 256	2198 694
	Kilo, SV1, SD1, SD2, SC1, SC2, SC3 . . . . .		1	2291 233	2258 257	2198 695
	Mile, SD3 . . . . .	8	1	----	2097 819	
	Calibrated, SP1, SP2 . . . . .		1	----	2290 331	
	Calibrated, SD1, SD2 . . . . .		1	----	2258 260	
	Mile, 150, SC1, SC2 w/o High Performance, SC3 . . . . .		1	----	2290 394	2290 394
	Mile, 150, SC2, High Performance . . . . .	8	1	----	----	2198 696
8-37-373	HOUSING PACKAGE, Speedometer Instruments and Control . . . . .	6	1	2299 316		
8-37-387	GROMMET, Speedometer Mounting Screw . . . . .		2	----	2209 214	
8-37-389	SCREW, Speedometer Instrument and Controls Bezel Mounting, SV1 . . . . .	6	4	2258 398		
	Upper, SL1 . . . . .	6	2	2258 398		
	Lower, SL1 . . . . .	6	2	9416 370		
8-37-410	LENS, Speedometer, Mile, SD3 . . . . .	8	1	----	2097 826	
8-37-418	SCREW, Speedometer Dial Mounting, SD1, SD2 . . . . .		2	----	2258 385	
8-37-458	CABLE, Odometer Reset, SY1 . . . . .	8	1	----	----	2197 271
8-37-459	NUT, Odometer Reset Cable Mounting to Panel, SY1 . . . . .	8	1	----	----	1886 089
8-37-504	TACHOMETER, 6000 R.P.M., SC2-300H . . . . .	8	1	----	----	2256 218
8-30-508	CABLE, Tachometer, SC2-300H . . . . .	8	★	----	----	*2426 286
8-37-517	SHAFT, Tachometer Cable Drive, SC2-300H . . . . .	8	1	----	----	2096 976
<b>8-38-O GLOVE COMPARTMENT LIGHT</b>						
8-38-4	BEZEL and LENS, Glove Box Lamp, SY1 . . . . .	8	1	----	----	1819 441
8-38-23	LAMP and SWITCH, Glove Box, SD3 . . . . .	8	1	----	2258 436	2258 436
<b>8-39-O HEADLAMP BEAM INDICATOR LIGHT</b>						
8-39-3	BEZEL and HOUSING, High Beam Indicator Lamp, SD3 . . . . .	8	1	----	2257 723	
8-39-15	SOCKET, High Beam Indicator Lamp, SD1, SD2 . . . . .		1	2097 003	2097 003	2097 003

★ Indicates use as required.      Numerals in parentheses ( ) refer to notes.      Printed in U.S.A.  
 ☐ Indicates parts not listed in any previous parts book.      Prices and specifications subject to change without notice.  
 March 8, 1963 Supersedes May 1, 1962.      Page 8-42      \* Indicates change or addition.

CODE	PART NAME AND DESCRIPTION	C Y L.	PER CAR	VALIANT LANCER	PLYMOUTH DODGE	CHRYSLER IMPERIAL
<b>8-39-O HEADLAMP BEAM INDICATOR LIGHT - Cont'd</b>						
8-39-15	SOCKET - Cont'd					
	SP1, SP2 . . . . .	8	1	-----	2257 440	-----
	w/CABLE, SD3 . . . . .		1	-----	2257 722	
	Printed Circuit High Beam Indicator Lamp, SP1, SP2, SD1, SD2 . . . . .		1	-----	2257 440	
8-39-16	SPRING, Headlamp Beam Indicator Lamp Socket . . . . .		1	385 532	385 532	385 532
8-39-17	CONTACT, Headlamp Indicator Cable. . . . .		★	*2256 966	*2256 966	*2256 966
<b>8-40-O IGNITION LAMP</b>						
8-40-8	GASKET, Ignition and Starter Switch Lamp, SC1, SC2, SC3 . . . . .	8	1	-----	-----	1971 224
8-40-16	SOCKET, Ignition Switch Illuminated Lamp, SC1, SC2, SC3 . . . . .	8	1	-----	-----	2097 003
8-40-17	SPRING, Ignition Switch Lamp Socket Cable, SC1, SC2, SC3 . . . . .	8	1	-----	-----	385 532
8-40-19	CONTACT, Ignition Switch Lamp Socket Cable, SC1, SC2, SC3 . . . . .	8	1	-----	-----	*2256 966
<b>8-41-O INSTRUMENT PANEL LIGHT</b>						
8-41-35	DIFFUSER, Light, SV1 . . . . .	6	1	2290 362		
	SV1 . . . . .	6	1	2257 865		
	SL1 . . . . .	6	2	2257 865		
8-41-36	SOCKET, Instrument Lamp . . . . .	6	1	2096 374		
	Instrument Lamp, on Printed Circuit . . . . .	6	2	2257 440		
	Instrument Lamp, SD3 . . . . .	8	3	-----	2097 003	
	Speedometer Lamp, SD3 . . . . .	8	1	-----	2097 003	
	Instrument Lamp, on Printed Circuit, SP1, SP2 . . . . .		4	-----	2257 440	
8-41-37	SPRING, Instrument Lamp Socket, SC1, SC2, SC3 . . . . .	8	★	385 532	385 532	385 532
	SY1 . . . . .		★	-----	-----	*1842 340
8-41-38	WASHER, Instrument Lamp Socket Insulating, SC1, SC2, SC3 . . . . .	8	★	858 245	858 245	858 245
	SY1 . . . . .		★	-----	-----	6006 106
8-41-39	CONTACT, Instrument Lamp Socket Cable . . . . .		★	*2256 966	*2256 966	*2256 966
8-41-64	CONTACT, Speedometer Lamp Socket Cable . . . . .		★	*2256 966	*2256 966	*2256 966
8-41-65	SPRING, Speedometer Lamp Socket . . . . .		★	385 532	385 532	385 532
<b>8-42-O MAP LAMP</b>						
8-42-2	LENS, Switch and Bracket, Map Lamp, Cv. Cp. . . . .	8	1	-----	2084 672	
8-42-5	LENS, Map Lamp, SD3 . . . . .	8	1	-----	1887 954	
	Map and Courtesy Lamp, SC1, SC2, SC3 . . . . .	8	1	-----	-----	1887 329
8-42-6	HOUSING and LENS, Map Lamp, SD3 . . . . .	8	1	-----	1887 955	
8-42-10	SOCKET, Map Lamp, SD3 . . . . .	8	1	-----	1704 875	
	Map Lamp, Cv. Cp., SP2, SD2 . . . . .	8	1	-----	1314 619	
	SY1 . . . . .	8	1	-----	-----	1971 879
		8	1	-----	-----	1704 467

★ Indicates use as required.

Numerals in parentheses ( ) refer to notes.

Printed in U.S.A.

□ Indicates parts not listed in any previous parts book.

Prices and specifications subject to change without notice.

\* Indicates change or addition.

March 8, 1963 Supersedes May 1, 1962.

## 1962 PASSENGER CAR PARTS CATALOG

ELECTRICAL

CODE	PART NAME AND DESCRIPTION	C Y L.	PER CAR	VALIANT LANCER	PLYMOUTH DODGE	CHRYSLER IMPERIAL
<b>8-42-O MAP LAMP - Cont'd</b>						
8-42-11	SPRING, Map Lamp Socket . . . . .		★	----	*1842 340	*1842 340
8-42-12	CONTACT, Map Lamp Socket . . . . .		★	----	*2256 966	*2256 966
8-42-25	SWITCH, Map Lamp, SD3 . . . . .	8	1	----	1972 669	
	Map or Dome Lamp, SC1, SC2, SC3 . . . . .	8	2	----	----	1972 669
	Map and Courtesy Lamp Housing and Map, SY1 . . . . .	8	1	----	----	2198 090
	Map and Courtesy Lamp Housing with Power Antenna, SY1 . . . . .	8	1	----	----	2257 429
8-42-26	NUT, Map Lamp Switch Mounting, SC1, SC2, SC3 . . . . .	8	1	----	----	1971 521
8-42-29	BEZEL, Map Lamp Switch Mounting, SD3 . . . . .	8	1	----	1887 789	----
8-42-31	KNOB, Map Lamp Switch, SD3, SC1, SC2, SC3 . . . . .	8	1	----	2257 478	2257 955
<b>8-44-O BULB</b>						
8-44-1	BULB, Oil Warning Lamp, SP1, SP2 . . . . .		1	127 934	127 934	
	Low Oil Pressure Indicator Lamp, SD1, SD2 . . . . .		1	----	127 934	
	High Beam Indicator Lamp . . . . .		1	127 934	127 934	127 934
	High Beam Indicator Lamp, SY1 . . . . .	8	1	----	----	274 004
	Turn Signal Indicator Lamp . . . . .		1	127 934	127 934	
	Turn Signal Indicator Lamp . . . . .		2	----	----	127 934
	Instrument Lamp, on Printed Circuit . . . . .	6	2	127 934		
	Instrument Lamp, on Printed Circuit, SP1, SP2 . . . . .	6	4	----	127 934	
	Instrument Lamp . . . . .		★	127 934		
	Dome Lamp . . . . .		1	151 578	151 578	151 578
	Dome Lamp, Rear, Sub., SC1, SC3 . . . . .		1	----	151 578	151 578
	Tail, Stop and Turn Signal Lamp . . . . .		2	151 567	151 567	151 567
	Open Door Indicator Lamp . . . . .		1	142 451	142 451	
	Back-Up Lamp, SL1, SD1 Sub., SD2 Sub., SY1 . . . . .		2	142 456	151 576	151 577
	Back-Up Lamp, except Sub., SD1, SD2 . . . . .		2	----	142 456	
	Back-Up Lamp, SV1, SP1, SP2, SC1, SC2, SC3 . . . . .		2	151 576	151 576	151 576
	Glove Box . . . . .		1	152 244	152 244	152 244
	Underhood Lamp . . . . .		1	151 578	151 578	151 578
	Trunk Lamp, SC1, SC2, SC3 . . . . .		1	151 578	151 578	151 578
	Trunk Lamp, SY1 . . . . .	8	1	----	----	151 577
	Parking and Turn Signal Lamp . . . . .		2	151 567	151 567	151 567
	Courtesy Lamp, except Cv. Cp. . . . .		2	142 453	142 453	
	Map Lamp, Cv. Cp. . . . .	8	1	----	142 453	
	Rear Pocket Panel Courtesy Lamp, Cv. Cp., SY1 . . . . .	8	2	----	142 453	142 453
	Map Lamp Socket . . . . .	8	1	----	----	151 578
	Quarter Arm Rest Courtesy Lamp Socket, Cv. Cp., SC1, SC2, SC3 . . . . .	8	2	----	----	142 453
	Parking Brake Indicator Lamp . . . . .		1	142 453	142 453	127 934
	Emergency Flasher Indicator Lamp . . . . .		1	127 934	127 934	
	License Lamp, SY1 . . . . .		1	142 450	----	142 450
	License Lamp, SP1, SP2 . . . . .		2	----	142 450	
	License Lamp, Sub., SD1, SD2, SC1, SC3 . . . . .		2	----	142 450	142 450
	License Lamp, except Sub., SD1, SD2, SC1, SC2, SC3 . . . . .		1	----	142 450	142 450
	Push Button Gearshift Lamp, SP1, SP2, SC1, SC2, SC3 . . . . .		1	----	152 280	152 240
	Instrument Push Button Title Illuminated Socket, SD1, SD2 . . . . .		2	----	127 934	
	Instrument Gauges Illuminated Socket, SD1, SD2 . . . . .		3	----	127 934	
	Ash Receiver Lamp . . . . .	8	1	----	----	131 282
	Auto. Pilot Illuminated Lamp, SC1, SC2, SC3 . . . . .	8	1	----	----	152 240
	Ignition Switch Illuminated Lamp Socket, SC1, SC2, SC3 . . . . .	8	1	----	----	152 240

★ Indicates use as required.

Numerals in parentheses ( ) refer to notes.

Printed in U.S.A.

☐ Indicates parts not listed in any previous parts book.

Prices and specifications subject to change without notice.

March 8, 1963 Supersedes May 1, 1962.

\* Indicates change or addition.



CODE	PART NAME AND DESCRIPTION	CYL.	PER CAR	VALIANT LANCER	PLYMOUTH DODGE	CHRYSLER IMPERIAL
<b>8-47-0 LICENSE MOUNTING PARTS</b>						
8-47-8	BRACKET, License Plate, Front, SV1 . . . . .	6	2	2082 172		
	Front, SL1 . . . . .	6	2	2208 620		
	Front, w/GUARDS, B. E., SY1 . . . . .	8	2	-----	-----	2123 802
8-47-14	SCREW and WASHER, Front License Plate Bracket Mounting to Front Stone Deflector, SV1 . . . . .	6	2	6008 218		
	Front License Plate, SV1 . . . . .	6	2	6022 506		
	Front License Plate to Front License Plate Bracket, SL1 . . . . .	6	2	6023 349		
	Front License Plate to Front Bumper, SP1, SP2, SD3, SC1, SC2, SC3 . . . . .		2	-----	6023 349	
	Front License Plate to Front Bumper, SD1, SD2.		2	-----	6022 506	
	BOLT, Front Bumper License Bracket to License, SY1 . . . . .	8	2	-----	-----	181 055
	SCREW and WASHER, Front License Plate to Front License, SY1 . . . . .	8	2	-----	-----	6006 218
8-47-15	SPEED NUT, Rear License Plate, SV1 . . . . .	6	2	6023 269		
	Front License Plate to Front License Plate Bracket, SL1 . . . . .	6	2	6023 269		
	Rear License Plate to Rear Stone Deflector, SL1 . . . . .	6	2	6023 269		
	Bumper to License Plate . . . . .		*	-----	6012 049	6012 049
	Front Bumper License Bracket to License Bolt, SY1 . . . . .	8	2	-----	-----	6012 054
8-47-21	BUTTON, Front License Plate Bracket to License Plate, SL1 . . . . .	6	2	1943 547		
	Front Bumper to License Plate, SC1, SC2, SC3 .		1	-----	1943 547	1943 547
	Rear Bumper to License Plate Screw, 4 D. Sub., SC1, SC3 . . . . .		1	-----	1943 547	1943 547
	Rear Bumper to License Plate, SY1 . . . . .	8	1	-----	-----	1943 547
8-47-57	FRAME, License Plate . . . . .	8	1	-----	-----	1829 058
8-47-67	SPRING, License Plate Mounting Panel Hinge, except Sub., SC1, SC2, SC3 . . . . .		1	-----	1960 131	1960 131
8-47-68	PANEL, License Plate Mounting, Complete, White, except Sub., SC1, SC2, SC3 . . . . .		1	-----	2094 647	2094 647
	Partial, except Sub., SC1, SC2, SC3 . . . . .		1	-----	2188 619	2188 619
8-47-69	HINGE and BOLT, License Plate Mounting Panel, except Sub., SC1, SC2, SC3 . . . . .		1	-----	2094 641	2094 641
8-47-76	PIN, License Plate Mounting Panel Hinge, except Sub., SC1, SC2, SC3 . . . . .		1	-----	1960 127	1960 127
8-47-77	NUT, License Plate Mounting Panel Hinge, except Sub., SC1, SC2, SC3 . . . . .		2	-----	6023 351	6023 351
8-47-79	RETAINER, License Plate Mounting Panel Hinge Pin, except Sub., SC1, SC2, SC3 . . . . .		1	-----	6006 324	6006 324
8-47-93	SPACER, Front Bumper to License Plate, SD1, SD2 . . . . .		2	-----	2203 756	
8-47-126	BUMPER, Front License Plate Bracket, SV1 . . .	6	2	1698 868		
	Rear, License Plate . . . . .	6	2	729 152		
	Rear, License Insert, except Sub., SP1, SP2 . .		2	-----	729 152	
	Rear, License Plate Mounting Plate, except Sub., SC1, SC2, SC3 . . . . .		2	-----	2094 618	2094 618

★ Indicates use as required.

Numerals in parentheses ( ) refer to notes.

Printed in U.S.A.

☐ Indicates parts not listed in any previous parts book.

Prices and specifications subject to change without notice.

\* Indicates change or addition

March 8, 1963 Supersedes May 1, 1962.

# 1962 PASSENGER CAR PARTS CATALOG

ELECTRICAL

CODE	PART NAME AND DESCRIPTION	CYL	PER CAR	VALIANT LANCER	PLYMOUTH DODGE	CHRYSLER IMPERIAL
<b>8-47-O LICENSE MOUNTING PARTS - Cont'd</b>						
8-47-126	BUMPER - Cont'd License Plate Mounting Panel, except Sub., SP1, SP2, SD3, SC1, SC2, SC3 . . . . .		2	----	2094 618	2094 618
	License Plate Mounting Panel, except Sub., SD1, SD2 . . . . .		2	----	2252 184	
8-47-130	SCREW and WASHER, Rear License Plate, except Sub., SV1 . . . . .	6	2	6023 349		
	Rear License Plate to Rear Stone Deflector, except Sub., SL1 . . . . .	6	2	6023 349		
	Rear License Plate to License Mounting Panel, except Sub., SC1, SC2, SC3 . . . . .		2	----	6022 506	6022 506
	Rear License Plate to Rear Bumper, Sub., SC1, SC3 . . . . .		2	----	6023 349	6023 349
	Rear License Plate to Rear Bumper, SY1 . . . . .	8	2	----	----	6023 349
8-47-131	NUT, License Plate . . . . .	6	2	2093 721		
	License Insert, except Sub., SP1, SP2 . . . . .		2	----	6006 478	
	NUT and WASHER, Rear License Plate to License Panel, except Sub., SC1, SC2, SC3 . . . . .		2	----	6023 271	6023 271
	Front License Plate to Front Bumper, SD1,SD2		2	----	6023 271	
	Front License Plate Bracket to Front Bumper, SY1 . . . . .	8	2	----	----	6023 271
<b>8-50-O PARKING AND DIRECTIONAL LAMP</b>						
8-50-82	SWITCH, Turn Signal, SP1, SP2, SD1, SD2, SY1 . . . . .		1	2258 700	2258 700	2197 376
	SD3, SC1 Police . . . . .	8	1	----	1972 196	1972 196
	SWITCH and CABLE, Turn Signal Electric, SD3, SC1 Police, SY1 . . . . .		1	2096 735	2096 735	
8-50-98	SWITCH, Turn Signal Actuating, SC1, SC2, SC3 . . . . .	8	1	----	----	1971 750
8-50-101	BRACKET, Turn Signal Actuating Switch Mounting, SC1, SC2, SC3 . . . . .	8	1	----	----	*1971 753
8-50-103	ARM PACKAGE, Turn Signal Switch Operating, SD3, SC1 Police . . . . .	8	1	----	2084 304	2084 304
	SY1 . . . . .	8	1	----	----	2240 250
8-50-104	PIVOT, Turn Signal Switch Operating Arm, SD3, SC1 Police, SY1 . . . . .	8	1	----	1972 207	1972 207
8-50-125	SWITCH and BRACKET, Turn Signal Cancelling, SC1, SC2, SC3 . . . . .	8	1	----	----	2257 267
8-50-126	CAM, Turn Signal Switch Cancelling, SP1, SP2, SD1, SD2 . . . . .		1	2258 704	2258 704	
	FINGER, Turn Signal Switch Cancelling, SD3 w/o Power Steering, SC1 Police . . . . .	8	1	----	2197 170	2197 170
	FINGER, Turn Signal Switch Cancelling, SD3 w/ Power Steering, SY1 . . . . .	8	1	----	1972 201	1972 201
8-50-129	LEVER and KNOB, Turn Signal Switch, SP1, SP2, SD1, SD2, SC1 Police . . . . .		1	2258 710	2258 710	2291 539
	SD3 . . . . .	8	1	----	2290 882	
	LEVER, SY1 . . . . .	8	1	----	----	2197 375
8-50-130	SCREW, Turn Signal Switch Lever Mounting . . . . .		1	6023 490	6023 490	
	Mounting to Arm, SY1 . . . . .	8	1	----	----	159 929
8-50-133	KNOB, Turn Signal Actuating Switch, SC1, SC2, SC3 . . . . .	8	1	----	----	1971 751

★ Indicates use as required. Numerals in parentheses ( ) refer to notes. Printed in U.S.A.  
 † Indicates parts not listed in any previous parts book. Prices and specifications subject to change without notice.  
 March 8, 1963 Supersedes May 1, 1962. \* Indicates change or addition.

CODE	PART NAME AND DESCRIPTION	C Y L.	PER CAR	VALIANT LANCER	PLYMOUTH DODGE	CHRYSLER IMPERIAL
<b>8-50-0 PARKING AND DIRECTIONAL LAMP - Cont'd</b>						
8-50-135	PLATE, Turn Signal Switch Contact, SD3, SC1 Police, SY1 . . . . .	8	1	----	2196 322	2196 322
8-50-156	SOCKET, Turn Signal Indicator Lamp, SP1, SP2 . SD1, SD2 . . . . . w/CABLE, SD3 . . . . .	8 8 8	1 1 2	2257 440 ---- ----	2257 440 1753 632 2257 720 ----	2097 003
8-50-157	SPRING, Turn Signal Lamp . . . . .		★	385 532	385 532	385 532
8-50-159	CONTACT, Socket . . . . .		★	*2256 966	*2256 966	*2256 966
8-50-170	LENS, Turn Signal Lamp, SY1 . . . . .	8	2	----	----	2198 863
8-50-171	BEZEL and HOUSING, Turn Signal Lamp, SD3 . .	8	1	----	2257 719	
8-50-186	FLASHER, Turn Signal . . . . .		1	*2426 166	*2426 166	*2426 166
8-50-191	CLIP, Turn Signal Flasher Mounting . . . . .		1	6015 159	6015 159	6015 159
8-50-218	EXTENSION, Turn Signal Switch Wiring, SC1 Police .	8	1	----	----	2291 504
8-50-303	LAMP, Parking and Turn Signal, Right, SV1, SP1, SP2, SC1, SC2, SC3 . . . . . Left, SV1, SP1, SP2, SC1, SC2, SC3 . . . . . Right, SD1, SD2, SY1 . . . . . Left, SD1, SD2, SY1 . . . . . w/HOUSING, SD3 . . . . .	1 1 1 1 8	1 1 1 1 2	2243 482 2243 483 ---- ---- ----	2252 104 2252 105 2189 410 2189 411 2094 601	2188 438 2188 439 2188 852 2188 853
8-50-304	LAMP PACKAGE, Parking and Turn Signal, SL1 .	6	2	2240 263		
8-50-307	NUT, Parking and Turn Signal Lamp Housing Attaching, SD1, SD2 . . . . . Parking and Turn Signal Lamp, SP1, SP2, SD1, SD2.	4 4		---- ----	6023 251 6023 251	
8-50-308	GASKET, Parking and Turn Signal Lamp, SV1, SP1, SP2, SY1 . . . . . Housing, SC1, SC2, SC3 . . . . .	8 8	2 2	2093 350 ----	2093 350 ----	2188 864 2188 436
8-50-315	BEZEL, Parking and Turn Signal Lamp, SL1 . . . Right, SY1 . . . . . Left, SY1 . . . . .	6 8 8	2 1 1	2188 277 ---- ----	---- ---- ----	2188 856 2188 857
8-50-332	BRACKET, Parking and Turn Signal Lamp Support, Right, SD3 . . . . . Left, SD3 . . . . .	8 8	1 1	---- ----	2123 924 2123 925	
8-50-334	LENS and GASKET PACKAGE, Parking and Turn Signal Lamp, Right, SV1, SP1, SP2, SY1 . . . . Left, SV1, SP1, SP2, SY1 . . . . . Right, SD1, SD2 . . . . . Left, SD1, SD2 . . . . .	1 1 1 1	1 1 1 1	2275 212 2275 211 ---- ----	2275 212 2275 211 2279 930 2279 931	2240 742 2240 743
8-50-335	LENS, Parking and Turn Signal Lamp, SL1,SD3 . . Right, SC1, SC2, SC3 . . . . . Left, SC1, SC2, SC3 . . . . .	8 8 8	2 1 1	2188 279 ---- ----	2094 600 ---- ----	2188 432 2188 433
8-50-337	SCREW, Parking and Turn Signal Lamp Lens to Housing, SV1, SP1, SP2 . . . . . Lens Attaching, SV1, SP1, SP2 . . . . . Lens Attaching, SL1 . . . . . Lens Attaching, SL1 . . . . . Lamp to Housing, SD1, SD2 . . . . .	2 2 6 6 4	2 2 2 2 4	6025 057 6023 141 9415 912 9414 111 ----	6022 820 6023 141 ---- ---- 6023 356	

★ Indicates use as required.

Numerals in parentheses ( ) refer to notes.

Printed in U.S.A.

☐ Indicates parts not listed in any previous parts book.

Prices and specifications subject to change without notice.

\* Indicates change or addition.

March 8, 1963 Supersedes May 1, 1962.

# 1962 PASSENGER CAR PARTS CATALOG

ELECTRICAL

CODE	PART NAME AND DESCRIPTION	C Y L	PER CAR	VALIANT LANCER	PLYMOUTH DODGE	CHRYSLER IMPERIAL
<b>8-50-0 PARKING AND DIRECTIONAL LAMP - Cont'd</b>						
8-50-337	SCREW - Cont'd Lamp, SD1, SD2 . . . . .		4	----	6022 154	
	Lens Attaching, SD3, SC1, SC2, SC3 . . . . .	8	4	----	6022 856	1903 385
	Lens Attaching, SY1 . . . . .	8	4	----	----	9416 628
	Lens Center, SY1 . . . . .	8	4	----	----	9417 788
	To Fender, SY1 . . . . .	8	4	----	----	9413 433
	To Plate, SY1 . . . . .	8	4	----	----	9417 789
8-50-338	GASKET, Parking and Turn Signal Lamp Lens, SL1, SC1, SC2, SC3 . . . . .		2	2188 280	----	2188 434
	To Housing, SD1, SD2 . . . . .		1	----	2189 420	
8-50-349	SOCKET and CABLE, Parking and Turn Signal Lamp Housing, SL1 . . . . .	6	2	1903 387		
	SOCKET and CABLE, Parking and Turn Signal Lamp, SV1, SP1, SP2, SY1 . . . . .		2	1903 387	2252 100	2198 223
	SD1, SD2, SD3 . . . . .		2	----	2188 712	
	SC1, SC2, SC3 . . . . .	8	2	----	----	2252 100
<b>8-52-0 STARTING MOTOR</b>						
8-52-4	STARTING MOTOR, Assembly, SP1, SP2, SD1, SD2, . w/Auto., Trans. SD3 . . . . .	8	1	2095 150	2095 150	2095 150
	w/Std. Trans., SD3, SC1, SC2 . . . . .	8	1	----	1889 200	1889 200
8-52-39	SEAL, Cylinder Block to Starter, Approx. 3-1/3" I.D. . . . .	6	1	2128 412	2128 412	
	w/High Performance, SP2, SD2 . . . . .	8	1	----	2129 234	
	w/Auto., Trans. SD3 . . . . .	8	1	----	2129 234	2129 234
	w/Std. Trans., SD3, SC1, SC2, approx. 3-1/3" I.D. . . . .	8	1	----	2128 412	2128 412
	w/Std. Trans., SD3, SC1, SC2, Approx. 3-1/2" I.D. . . . .	8	1	----	2128 285	2128 285
8-52-328	RELAY, w/Std. Trans., SC1, SC2 . . . . .		1	2095 609	2095 609	2095 609
	w/Auto. Trans. . . . .		1	2095 608	2095 608	2095 608
8-52-368	CLIP, Starter Cable Rear Out Board Exhaust Manifold Bolt . . . . .	6	1	6015 235		

FOR MODEL APPLICATION SEE CODE 8-52-4

STARTING MOTOR AND COMPONENT PARTS		STARTER ASSEMBLIES	
		1889 200	2095 150
8-52-5	STUD, Mounting Lower . . . . .	----	2095 875
	SCREW and WASHER, Mounting Upper . . . . .	----	*6023 899
8-52-6	NUT, Mounting Stud, Lower . . . . .	----	271 506
8-52-41	CLUTCH . . . . .	1889 129	2095 122
8-52-49	FORK and PIN PACKAGE, Shifting . . . . .	2084 093	----
	FORK, Shifting . . . . .	----	2095 134
8-52-50	PIN, Shifting Fork Pivot . . . . .	----	2095 133
8-52-61	RING, Clutch Actuator Retaining . . . . .	----	2095 130
8-52-67	SNAP RING, Clutch Drive Sleeve . . . . .	2095 350	----
	SNAP RING, Pinion Shaft Gear Retainer . . . . .	----	2095 117
	SNAP RING, Shaft . . . . .	1752 375	----

★ Indicates use as required.

Numeral in parentheses ( ) refer to notes.

Printed in U.S.A.

⊠ Indicates parts not listed in any previous parts book.

Prices and specifications subject to change without notice.

March 8, 1963 Supersedes May 1, 1962.

\* Indicates change or addition.

**8-52-0 STARTING MOTOR - Cont'd**

FOR MODEL APPLICATION SEE CODE 8-52-4

STARTING MOTOR AND COMPONENT PARTS		STARTER ASSEMBLIES	
		1889 200	2095 150
8-52-76	HOUSING, Pinion . . . . .	1889 154	---- --
8-52-80	BEARING, Pinion Housing . . . . .	2095 410	2095 410
	BEARING, End Head . . . . .	---- --	2095 242
8-52-82	STOP, SNAP RING, and STOP WASHER PACKAGE, Pinion . . . . .	1881 727	---- --
8-52-86	HOUSING and BEARING, Gear . . . . .	---- --	2095 112
8-52-87	ACTUATOR and RETAINING RING PACKAGE, Clutch Shifting . . . . .	---- --	2275 556
8-52-88	BOOT, Shifting Fork . . . . .	1889 147	---- --
8-52-89	SHAFT, Pinion . . . . .	---- --	2095 118
8-52-96	GEAR and SNAP RING PACKAGE, Pinion Shaft . . . . .	---- --	2275 557
8-52-98	THRUST WASHER and RETAINING RING PACKAGE, Pinion Shaft . . . . .	---- --	2275 558
8-52-100	RING, Pinion Shaft Retaining . . . . .	---- --	6022 006
8-52-101	COVER, Gear Housing . . . . .	---- --	2095 116
8-52-120	ARMATURE . . . . .	1889 079	2095 094
8-52-121	THRUST WASHER PACKAGE, Armature . . . . .	---- --	2275 555
8-52-135	BRUSH PACKAGE . . . . .	2240 749	
8-52-137	PLATE and BRUSH PACKAGE, Brush Holder . . . . .	---- --	2275 550
8-52-139	SPRING, Brush . . . . .	636 841	636 841
8-52-140	SPRING PACKAGE, Brush . . . . .	2084 666	2084 666
8-52-150	PLATE, Brush Holder . . . . .	1889 044	---- --
8-52-176	HEAD, Commutator End . . . . .	1889 363	2095 076
8-52-180	THRUST WASHER PACKAGE, Commutator End . . . . .	2240 529	---- --
8-52-214	FIELD SERIES and SHUNT COIL PACKAGE . . . . .	2084 088	2275 248
	COIL, Field Series, Complete . . . . .	---- --	2095 085
8-52-227	RIVET, Field Series Coil Ground . . . . .	---- --	2095 347
8-52-241	BOLT, Thru . . . . .	1889 080	2095 105
8-52-341	CONTACT and COVER GASKET PACKAGE, Solenoid . . . . .	2084 091	---- --
8-52-342	CONTACT and SPRING PACKAGE, Solenoid Switch . . . . .	---- --	2275 553
8-52-344	COVER and GASKET PACKAGE, Solenoid . . . . .	2084 090	---- --
8-52-345	SOLENOID PACKAGE . . . . .	1889 146	2275 554
8-52-354	STUD PACKAGE, Terminal Relay . . . . .	2084 094	*2421 837
8-52-375	CORE, Solenoid Moving . . . . .	1889 151	2095 155
8-52-389	SEAL, Solenoid Contact . . . . .	---- --	*2098 660

★ Indicates use as required.

Numerals in parentheses ( ) refer to notes.

Printed in U.S.A.

☐ Indicates parts not listed in any previous parts book.

Prices and specifications subject to change without notice.

\* Indicates change or addition.

Page 8-49

March 8, 1963 Supersedes May 1, 1962.

## 1962 PASSENGER CAR PARTS CATALOG

ELECTRICAL

CODE	PART NAME AND DESCRIPTION	CYL.	PER CAR	VALIANT LANCER	PLYMOUTH DODGE	CHRYSLER IMPERIAL
<b>8-53-O SWITCHES</b>						
8-53-150	SWITCH, Foot Dimmer . . . . .		1	1881 938	1881 938	1881 938
8-53-234	SCREW, Instrument Housing to Switch Bezel Mounting, SC1, SC2, SC3 . . . . .	8	2	-----	-----	2257 448
8-53-266	CIRCUIT BREAKER, Rear Compartment Cigar Lighter, w/o Window Lift and Electric Seat, 8 amp., SY1 . . . . .	8	1	-----	-----	1642 386
	w/Electric Window Lift and 6 Way Shift, SY1 . . . . .	8	1	-----	-----	1642 477
8-53-267	BRACKET, Circuit Breaker Mounting, SY1 . . . . .	8	1	-----	-----	1479 060
8-53-270	SWITCH, Headlamp and Instrument Lamp, SP1, SP2, SD1, SD2 . . . . .		1	2298 855	2275 587	2275 586
	SD3 . . . . .	8	1	-----	2209 329	
8-53-294	BEZEL, Headlamp and Instrument Lamp Switch, SP1, SP2 . . . . .		1	-----	2256 432	
8-53-296	KNOB and STEM PACKAGE, Headlamp and Instrument Lamp Switch, SL1 . . . . .	6	1	2275 585		
	KNOB and STEM PACKAGE, SV1 . . . . .	6	1	2298 883		
	KNOB, SP1, SP2, SY1 . . . . .		1	-----	2258 211	2258 027
	SD1, SD2, SC1, SC2, SC3 . . . . .		1	-----	2197 383	2257 951
	SD3 . . . . .	8	1	-----	2257 477	
8-53-298	SPRING, Headlamp and Instrument Lamp Switch Knob Retainer . . . . .	6	1	2076 145		
8-53-312	RETAINER, Headlamp and Instrument Lamp Switch, SD1, SD2 . . . . .		1	-----	2258 755	
8-53-317	BEZEL, Headlamp and Instrument Lamp Switch Mounting, SD3 . . . . .	8	1	-----	2097 503	
8-53-327	SWITCH or SENDING UNIT, Low Oil Pressure . . . . .	6	1	*2256 800	2256 800	
		8	1	-----	1818 830	
<b>8-55-O TAIL, STOP AND DIRECTIONAL SIGNAL LAMP</b>						
8-55-1	LAMP and GASKET PACKAGE, Tail, Stop and Turn Signal, Right, SV1 . . . . .	6	1	2279 919		
	Left, SV1 . . . . .	6	1	2279 920		
	LAMP PACKAGE, Tail, except Sub., SP1-M-H, SP2-M-H-P . . . . .		2	-----	2421 135	
	LAMP and WASHER PACKAGE, Tail, Stop and Turn Signal, SY1 . . . . .	8	2	-----	-----	2298 775
8-55-7	LAMP, Tail, Stop and Turn Signal, Right, except Sub., SL1 . . . . .	6	1	2189 452		
	Left, except Sub., SL1 . . . . .	6	1	2189 453		
	Right, Sub., SL1 . . . . .	6	1	2189 454		
	Left, Sub., SL1 . . . . .	6	1	2189 455		
	Except Sub., w/o Plate, SP1, SP2 . . . . .		2	-----	2189 054	
	Sub., w/2189 396 PLATE, SP1, SP2 . . . . .		2	-----	2189 054	
	Except Sub., SD1, SD2 except SD2-P . . . . .		2	-----	2189 176	
	Sub., SD1, SD2 . . . . .		2	-----	2189 300	
	Stop and Turn Signal, w/Bezel Moulding, Right, SD2-P . . . . .	8	1	-----	2252 272	
	Left, SD2-P . . . . .	8	1	-----	2252 273	
	Tail, SD2-P . . . . .	8	2	-----	2189 176	
8-55-8	GASKET, Tail, Stop and Turn Signal Lamp to Body, Sub., SD3, SC1, SC3 . . . . .	8	2	-----	2189 550	2189 550
8-55-9	NUT, Tail, Stop and Turn Signal Lamp, SP1, SP2 . . . . .		6	-----	9417 621	
	NUT, attaching, Sub., SP1, SP2 . . . . .		6	-----	6022 853	
	NUT, attaching, Sub., SD1, SD2 . . . . .		6	-----	6023 111	

★ Indicates use as required.

Numerals in parentheses ( ) refer to notes.

Printed in U.S.A.

□ Indicates parts not listed in any previous parts book.

Prices and specifications subject to change without notice.

March 8, 1963 Supersedes May 1, 1962.

Page 8-50

\* Indicates change or addition.

CODE	PART NAME AND DESCRIPTION	CYL	PER CAR	VALIANT LANCER	PLYMOUTH DODGE	CHRYSLER IMPERIAL
<b>8-55-0 TAIL, STOP AND DIRECTIONAL SIGNAL LAMP - Cont'd</b>						
8-55-9	NUT - Cont'd J/NUT, Attaching, Sub., SD3, SC1, SC3 . . . . .	8	8	----	6014 023	6014 023
	NUT, Tail, Stop and Turn Signal Lamp Bezel, except Sub., SD3, SC1, SC2, SC3 . . . . .	8	4	----	6008 043	6008 043
	NUT and WASHER, SY1 . . . . .	8	4	----	----	6022 162
8-55-10	SCREW, Tail, Stop and Turn Signal Lamp, SV1 . . Sub., SL1 . . . . .	6 6	6 8	6023 081 9413 316		
	SCREW, Attaching, Sub., SP1, SP2 . . . . .	6	6	----	9416 951	
	SCREW, Attaching, Sub., SC1, SC3 . . . . .	8	4	----	----	9417 580
	SCREW, Attaching, Sub., SC1, SC3 . . . . .	8	4	----	----	9417 581
	STUD, SY1 . . . . .	8	4	----	----	6023 080
8-55-23	PLATE, Tail, Stop and Turn Signal Lamp Mounting, Sub., SP1, SP2 . . . . .		2	----	2189 395	
	REINFORCEMENT, Rear Extension Tail, Stop and Turn Signal Lamp Mounting Plate, Sub., SP1, SP2 . . . . .		2	----	2255 382	
	REINFORCEMENT, Tail Lamp Opening, except Sub., SD3, SC1, SC2, SC3 . . . . .	8	2	----	2189 636	2189 636
8-55-57	SOCKET and BOOT, Tail, Stop and Turn Signal Lamp, SV1 . . . . .	6 6	2 2	2290 204 2096 410		
	SOCKET and BOOT, Tail Lamp, except Sub., SP1-M-H, SP2-M-H-P . . . . .		2	----	2096 648	
	Except Sub., SP1, SP2, SD1, SD2, SC1, SC2, SC3 SD3 . . . . .	8	2	----	2290 263	1841 893
	Sub., SD1, SD2 . . . . .		2	----	1841 893	
			2	----	2096 410	
8-55-63	SPRING, INSULATOR and CONTACT PACKAGE, Tail, Stop and Turn Signal Lamp Socket . . . . .		★	2198 860	2198 860	2198 860
	Tail Lamp, except Sub., SP1-M-H, SP2-H-M-P . .		★	----	2257 100	
8-55-136	HOUSING and REFLECTOR, Tail, Stop and Turn Signal Lamp, except Sub., SD3, SC1, SC2, SC3 . .	8	2	----	2189 767	2189 767
8-55-140	WELT, Tail, Stop and Turn Signal Lamp, except Sub., SD3, SC1, SC2, SC3 . . . . .	8	2	----	2252 358	2252 358
8-55-158	BEZEL, Tail, Stop and Turn Signal Lamp, Right, except Sub., SL1 . . . . .	6	1	2189 460		
	Left, except Sub., SL1 . . . . .	6	1	2189 461		
	Right, Sub., SL1, SD3, SC1, SC3 . . . . .	1	1	E2189 462	*2189 832	*2189 832
	Left, Sub., SL1, SD3, SC1, SC3 . . . . .	1	1	E2189 463	*2189 833	*2189 833
	BEZEL, Tail, Stop and Turn Signal Lamp, except Sub., Outer, SD1, SD2, except SD2-P . . . . .		2	----	E2189 189	
	BEZEL, Tail Lamp, Outer, SD2-P . . . . .	8	2	----	E2189 189	
	BEZEL, Tail, Stop and Turn Signal Lamp, Sub., Outer, SD1, SD2 . . . . .		2	----	E2189 302	
	BEZEL, LENS and GASKET PACKAGE, Sub., SD1, SD2 . . . . .		2	----	2279 925	
	BEZEL, LENS and GASKET PACKAGE, except Sub., SD1, SD2 except SD2-P . . . . .		2	----	2279 923	
	BEZEL, LENS and GASKET PACKAGE, Tail Lamp, SD2-P . . . . .		2	----	2279 923	
	BEZEL, Stop and Turn Signal Lamp, Right, SD2-P Left, SD2-P . . . . .	8 8	1 1	----	2189 178 2189 179	
	BEZEL, Tail, Stop and Turn Signal Lamp, except Sub., SD3, SC1, SC2, SC3 . . . . .	8	2	----	2189 529	2189 529
	SHELL, Tail, Stop and Turn Signal Lamp Socket, Sub., SD3, SC1, SC3 . . . . .	8	2	----	2189 834	2189 834

★ Indicates use as required.

Numerals in parentheses ( ) refer to notes.

Printed in U.S.A.

E Indicates parts not listed in any previous parts book.

Prices and specifications subject to change without notice.

\* Indicates change or addition.

March 8, 1963 Supersedes May 1, 1962.

# 1962 PASSENGER CAR PARTS CATALOG

ELECTRICAL

CODE	PART NAME AND DESCRIPTION	C Y L	PER CAR	VALIANT LANCER	PLYMOUTH DODGE	CHRYSLER IMPERIAL
<b>8-55-O TAIL, STOP AND DIRECTIONAL SIGNAL LAMP - Cont'd</b>						
8-55-159	STUD, Tail, Stop and Turn Signal Lamp Bezel Attaching, except Sub., SL1 . . . . .	6	6	6022 965		
	SCREW and WASHER, Tail, Stop and Turn Signal Lamp Bezel Attaching, except Sub., SD1, SD2 . . .		2	----	6023 488	
8-55-160	TAPE, Tail, Stop and Turn Signal Lamp Base, Outer, SY1 . . . . .	8	★	----	----	E2424 297
8-55-163	WASHER, Tail, Stop and Turn Signal Lamp Bezel Sealing, except Sub., SL1 . . . . .	6	2	6022 007		
8-55-194	LENS and GASKET PACKAGE, Tail, Stop and Turn Signal Lamp, SV1, SP1, SP2 . . . . .		2	2279 916	2275 247	
	SL1 . . . . .	6	2	2279 922		
	Right, Sub., SD3, SC1, SC3 . . . . .	8	1	----	2279 934	2279 934
	Left, Sub., SD3, SC1, SC3 . . . . .	8	1	----	2279 935	2279 935
	Except Sub., SD3, SC1, SC2, SC3 . . . . .	8	2	----	2298 774	2298 774
	SY1 . . . . .	8	2	----	----	2298 776
8-55-209	SCREW, Tail, Stop and Turn Signal Lamp Lens, SV1, SY1 . . . . .		6	6006 036	----	6023 390
	Sub., SD3, SC1, SC3 . . . . .	8	12	----	6022 594	6022 594
	Except Sub., SD3, SC1, SC2, SC3 . . . . .	8	4	----	6006 010	6006 010
	Outer Housing, SY1 . . . . .	8	2	----	----	6022 953
8-55-214	GASKET, Tail, Stop and Turn Signal Lamp Lens, Sub., SD3, SC1, SC3 . . . . .	8	2	----	2189 548	2189 548
	SY1 . . . . .	8	2	----	----	2189 560
8-55-220	REFLECTOR, Tail, Stop and Turn Signal Lamp, except Sub., SL1 . . . . .	6	2	*2189 464		
	Sub., SL1 . . . . .	6	2	*2189 466		
	SY1 . . . . .	8	2	----	----	E2189 562
8-55-293	SPRING, Tail, Stop and Turn Signal Lamp Socket .		★	*1842 340	*1842 340	*1842 340
8-55-300	CONTACT, Tail, Stop and Turn Signal Lamp Socket .		★	*2256 966	*2256 966	*2256 966
8-55-335	EXTENSION and INSERT PACKAGE, Tail, Stop and Turn Signal Lamp Bezel, Right, Sub., SC1, SC3 . . . . .	8	1	----	2279 932	2279 932
	Left, Sub., SD3, SC1, SC3 . . . . .	8	1	----	2279 933	2279 933
8-55-380	MOULDING, Stop and Turn Signal Lamp Bezel, Right, SD2-P . . . . .	8	1	----	2189 190	
	Left, SD2-P . . . . .	8	1	----	2189 191	
<b>8-56-O BACK-UP LAMP</b>						
8-56-1	LAMP, Back-Up, SV1 . . . . .	6	2	2189 517		
	Right, except Sub., SL1 . . . . .	6	1	2188 474		
	Left, except Sub., SL1 . . . . .	6	1	2188 475		
	Right, Sub., SL1 . . . . .	6	1	2188 476		
	Left, Sub., SL1 . . . . .	6	1	2188 477		
	Except Sub., SP1, SP2 . . . . .		2	----	2189 063	
	Sub., SD1, SD2 . . . . .		2	----	2189 309	
	Right, SD2-P . . . . .	8	1	----	2252 216	
	Left, SD2-P . . . . .	8	1	----	2252 217	
	w/Bezel Moulding, Right, except Sub., SD1-L-H, SD2-L-H . . . . .		1	----	2189 664	
	w/Bezel Moulding, Left, except Sub., SD1-L-H, SD2-L-H . . . . .		1	----	2189 665	
	Back-Up and License, Right, Sub., SD3 . . . . .	8	1	----	2094 988	
	Left, Sub., SD3 . . . . .	8	1	----	2094 989	

★ Indicates use as required.

Numerals in parentheses ( ) refer to notes.

Printed in U.S.A.

☐ Indicates parts not listed in any previous parts book.

Prices and specifications subject to change without notice.

March 8, 1963 Supersedes May 1, 1962.

\* Indicates change or addition.



CODE	PART NAME AND DESCRIPTION	C Y L	PER CAR	VALIANT LANCER	PLYMOUTH DODGE	CHRYSLER IMPERIAL
<b>8-56-O BACK-UP LAMP - Cont'd</b>						
8-56-1	LAMP - Cont'd					
	Back-Up and License, Right, Sub., SP1, SP2, SC1, SC3 . . . . .		1	----	2189 432	2094 988
	Left, Sub., SP1, SP2, SC1, SC3 . . . . .		1	----	2189 433	2094 989
	Right, SY1 . . . . .	8	1	----	----	1961 450
	Left, SY1 . . . . .	8	1	----	----	1961 451
8-56-2	SWITCH, Back-Up Lamp, w/Std. Trans., SC1, SC2 . w/Auto. Trans. . . . .		1	2258 404	2258 404	2258 404
			1	1971 833	1972 052	1972 052
8-56-4	NUT, Back-Up Lamp, except Sub., SP1, SP2 . . . .		6	----	9417 621	
	NUT, Housing Panel, SD2-P . . . . .	8	12	----	6023 276	
	J/NUT, Sub., SD1, SD2 . . . . .		6	----	6023 111	
	J/NUT, to Bumper, SY1 . . . . .	8	4	----	----	6022 142
8-56-7	LENS, Back-Up Lamp, SL1 . . . . .	6	2	2188 483		
	Back-Up and License Lamp, Right, Sub., SP1, SP2, SC1, SC3 . . . . .		1	----	2189 488	2094 992
	Left, Sub., SP1, SP2, SC1, SC3 . . . . .		1	----	2189 489	2094 993
	Back-Up and License Lamp, Right, Sub., SD3 . .	8	1	----	2094 992	
	Left, Sub., SD3 . . . . .	8	1	----	2094 993	
	Right, SY1 . . . . .	8	1	----	----	1961 434
	Left, SY1 . . . . .	8	1	----	----	1961 435
8-56-8	LENS and GASKET PACKAGE, Back-Up Lamp, SV1 . . . . .	6	2	2279 915		
	Except Sub., SP1, SP2 . . . . .		2	----	2275 246	
	Except Sub., SD1, SD2, except SD2-P . . . . .		2	----	2279 924	
	SD2-P . . . . .	8	2	----	2299 328	
	Sub., SD1, SD2 . . . . .		2	----	2279 926	
	Except Sub., SD3, SC1, SC2, SC3 . . . . .	8	2	----	2298 773	2298 773
8-56-10	SCREW, Back-Up Lamp Lens Attaching, SL1 . . . .	6	4	6022 047		
	To Quarter Panel, SL1 . . . . .	6	4	9413 316		
	Back-Up Lamp, SV1, SD2-P . . . . .		4	9417 427	6023 282	
	Back-Up and License Lamp, Sub., SP1, SP2 . . . .		4	----	9413 272	
	SP1, SP2, SD1, SD2 . . . . .		2	----	6025 081	
	Back-Up and License Lamp Lens, Sub., SP1, SP2 .		6	----	6006 010	
	Lens Attaching, except Sub., SP1, SP2 . . . . .		4	----	1877 956	
	Back-Up and License Lamp, Sub., SD3, SC1, SC3 . . . . .	8	6	----	9416 049	9416 049
	Back-Up and License Lamp Lens to Housing, Sub., SD3, SC1, SC3 . . . . .	8	6	----	6006 010	6006 010
	To Bumper, SY1 . . . . .	8	4	----	----	9415 540
8-56-23	GASKET, Back-Up Lamp Lens, SV1 . . . . .	6	2	2189 521		
	SL1 . . . . .	6	2	2189 685		
	SD2-P . . . . .	8	2	----	2252 214	
	Back-Up and License Lamp Lens, Sub., SP1, SP2 .		2	----	2189 490	
	Back-Up and License Lamp Lens, Sub., SD3, SC1, SC3 . . . . .	8	2	----	2094 994	2094 994
	Lens, SY1 . . . . .	8	2	----	----	1961 452
8-56-25	WASHER, Back-Up Lamp Socket . . . . .		★	6006 106	6006 106	6006 106
8-56-27	SPRING, Back-Up Lamp Socket . . . . .		★	*1842 340	*1842 340	*1842 340
	SPRING, INSULATOR and CONTACT PACKAGE . .		★	2257 100	2257 100	2257 100
8-56-33	CONTACT, Back-Up Lamp Socket . . . . .		★	*2256 966	*2256 966	*2256 966

★ Indicates use as required.

Numerals in parentheses ( ) refer to notes.

Printed in U.S.A.

□ Indicates parts not listed in any previous parts book.

Prices and specifications subject to change without notice.

\* Indicates change or addition.

# 1962 PASSENGER CAR PARTS CATALOG

ELECTRICAL

CODE	PART NAME AND DESCRIPTION	CY L.	PER CAR	VALIANT LANCER	PLYMOUTH DODGE	CHRYSLER IMPERIAL
<b>8-56-O BACK-UP LAMP - Cont'd</b>						
8-56-34	SOCKET, Back-Up Lamp, SL1 . . . . .		2	1878 128		
	SOCKET and BOOT, SV1 . . . . .	6	2	2096 141		
	SP1, SP2, SY1 . . . . .		2	----	2096 648	2096 648
	SOCKET and BOOT, Sub., SD1, SD2 . . . . .		2	----	2290 189	
	Except Sub., SD1, SD2, except SD2-P . . . . .		2	----	*2290 189	
	SD2-P . . . . .	8	2	----	2291 087	
	Except Sub., SD3, SC1, SC2, SC3 . . . . .	8	2	----	*2290 189	*2290 189
	Sub., SD3, SC1, SC3 . . . . .	8	2	----	2096 648	2096 648
8-56-35	CLIP, Back-Up Lamp Switch Wire, on Push Button Box, SY1 . . . . .	8	1	----	----	6015 329
8-56-36	BEZEL, Back-Up Lamp, Right, Sub., SL1 . . . . .	6	1	2188 480		
	Left, Sub., SL1 . . . . .	6	1	2188 481		
	Right, except Sub., SL1 . . . . .	6	1	2188 478		
	Left, except Sub., SL1 . . . . .	6	1	2188 479		
	Right, except Sub., SD1, SD2, except SD2-P . . . . .		1	----	2189 178	
	Left, except Sub., SD1, SD2 except SD2-P . . . . .		1	----	2189 179	
	BEZEL, Back-Up Lamp, except Sub., SD3, SC1, SC2, SC3 . . . . .	8	2	----	2189 530	2189 530
	BEZEL and GASKET PACKAGE, Right, SY1 . . . . .	8	1	----	----	2240 731
	Left, SY1 . . . . .	8	1	----	----	2240 732
8-56-40	GASKET, Back-Up Lamp, except Sub., SV1 . . . . .	6	2	2255 126		
	Housing, SD2-P . . . . .	8	2	----	2252 233	
8-56-41	STUD, Back-Up Lamp, SP2-P . . . . .	8	4	----	6022 296	
	SD2-P . . . . .	8	4	----	6023 282	
8-56-43	HOUSING, Back-Up Lamp, except Sub., SD3, SC1, SC2, SC3 . . . . .	8	2	----	2189 761	2189 761
8-56-44	GASKET, Back-Up Lamp Bezel, SL1 except Sub. . . . .	6	2	2188 485		
	SY1 . . . . .	8	2	----	----	1961 448
8-56-46	GASKET, Back-Up Lamp, Switch Hole Plug, w/Std. Trans., SC1, SC2 . . . . .		1	1302 807	1302 807	1302 807
	GASKET, Back-Up Lamp Switch, w/Std. Trans., SC1, SC2 . . . . .		1	1302 807	1302 807	1302 807
8-56-52	NUT, Back-Up Lamp Bezel, except Sub., SD3, SC1, SC2, SC3 . . . . .	8	4	----	6008 043	6008 043
	Back-Up Lamp Housing to Lens Bezel, SY1 . . . . .	8	8	----	----	1961 505
8-56-63	PLUG, Back-Up and License Lamp Button, Sub., SP1, SP2 . . . . .		2	----	2094 697	
	Back-Up Lamp Housing Socket Hole, Sub., SD3, SC1, SC3 . . . . .	8	2	----	2094 697	2094 697
	Housing, except Sub., SD3, SC1, SC2, SC3 . . . . .	8	2	----	2094 697	2094 697
8-56-73	PANEL, Deck Opening Lower Panel and Back-Up Lamp Housing, Right, SD2-P . . . . .	8	1	----	2252 208	
	Left, SD2-P . . . . .	8	1	----	2252 209	
8-56-75	MOULDING, Back-Up Lamp, Right, except Sub., SD1-L-H, SD2-L-H . . . . .		1	----	2189 190	
	Left, except Sub., SD1-L-H, SD2-L-H . . . . .		1	----	2189 191	
<b>8-57-O LICENSE PLATE LAMP</b>						
8-57-7	PLUG, License Lamp Button, Sub., SP1-L, M, SP2-L, M, SD1, SD2 . . . . .		2	----	2094 697	

★ Indicates use as required. Numerals in parentheses ( ) refer to notes. Printed in U.S.A.  
 ☐ Indicates parts not listed in any previous parts book. Prices and specifications subject to change without notice.  
 March 8, 1963 Supersedes May 1, 1962. \* Indicates change or addition.

CODE	PART NAME AND DESCRIPTION	C Y L.	PER CAR	VALIANT LANCER	PLYMOUTH DODGE	CHRYSLER IMPERIAL
<b>8-57-O LICENSE PLATE LAMP - Cont'd</b>						
8-57-10	LAMP, License . . . . .	6	1	2093 340		
	Except Sub., SD1, SD2 . . . . .		1	----	2189 952	
	Except Sub., SP1, SP2, SC1, SC2, SC3 . . . . .		1	----	2243 188	1878 196
	Except Sub., SD3 . . . . .	8	1	----	1878 196	
	Right, Sub., SP1-L, M, SP2-L, M, SD1, SD2 . . . . .		1	----	2189 434	
	Left, Sub., SP1-L, M, SP2-L, M, SD1, SD2 . . . . .		1	----	2189 435	
	SY1 . . . . .	8	1	----	----	2188 824
8-57-11	SCREW, License Lamp Attaching, except Sub., SC1, SC2, SC3 . . . . .		2	----	1878 893	1878 893
	Sub., SP1-L, M, SP2-L, M, SD1, SD2 . . . . .		4	----	9413 272	
	Lens, Sub., SP1, SP2 . . . . .		6	----	6006 010	
	SP1-L, M, SP2-L, M . . . . .		2	----	6025 081	
8-57-13	NUT, License Lamp, SY1 . . . . .	8	2	----	----	6006 297
8-57-15	GASKET, License Lamp, Sub., SP1-L, M, SP2-L, M, SD1, SD2 . . . . .		2	----	2252 383	
8-57-54	LENS and GASKET PACKAGE, License Lamp, SY1 . . . . .		1	1879 566	----	1879 566
8-57-55	LENS, License Lamp, Right, Sub., SP1-L, M, SP2-L, M, SD1, SD2 . . . . .		1	----	2189 486	
	Left, Sub., SP1-L, M, SP2-L, M, SD1, SD2 . . . . .		1	----	2189 487	
8-57-79	SOCKET and CABLE, License Lamp, SY1 . . . . .		1	2094 628	----	2094 628
	SP1, SP2 . . . . .		2	----	2096 141	
	Sub., SD1, SD2, SD3, SC1, SC3 . . . . .		2	----	2096 141	2096 141
	Except Sub., SD1, SD2, SD3, SC1, SC2, SC3 . . . . .		1	----	2096 141	2096 141
8-57-89	SPRING, License Lamp Socket . . . . .		★	*1842 340	*1842 340	*1842 340
	SPRING, INSULATOR and CONTACT PACKAGE . . . . .		★	2257 100	2257 100	2257 100
8-57-90	WASHER, License Lamp Socket . . . . .		★	6006 106	6006 106	6006 106
8-57-109	CONTACT, License Lamp Cable . . . . .		★	*2256 966	*2256 966	*2256 966
<b>8-58-O STOP LAMP</b>						
8-58-60	SWITCH, Stop Lamp, Mechanical Type . . . . .		1	2291 382	2258 864	2258 864
8-58-61	SCREW and WASHER, Stop Lamp Switch Mounting . . . . .		1	*6023 541	6023 541	6023 541

## NOTES

★ Indicates use as required.

Numerals in parentheses ( ) refer to notes.

Printed in U.S.A.

◻ Indicates parts not listed in any previous parts book.

Prices and specifications subject to change without notice.

\* Indicates change or addition.

