

GROUP 24 - AIR CONDITIONING

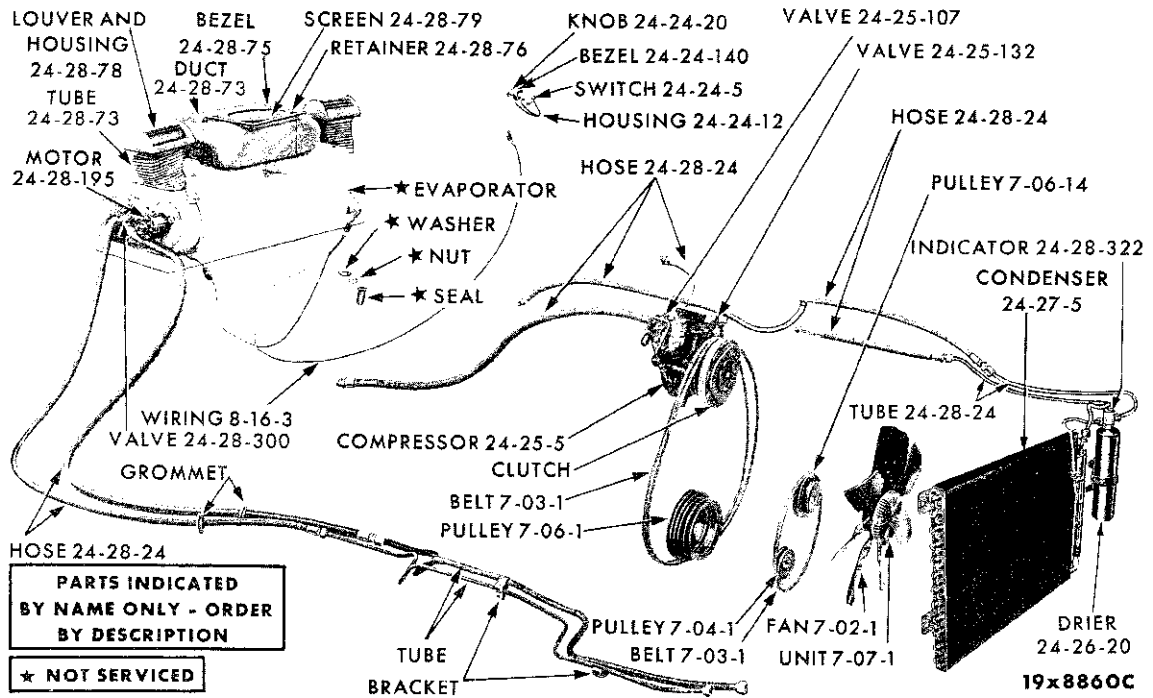

AIR CONDITIONING SYSTEM - TRUNK TYPE

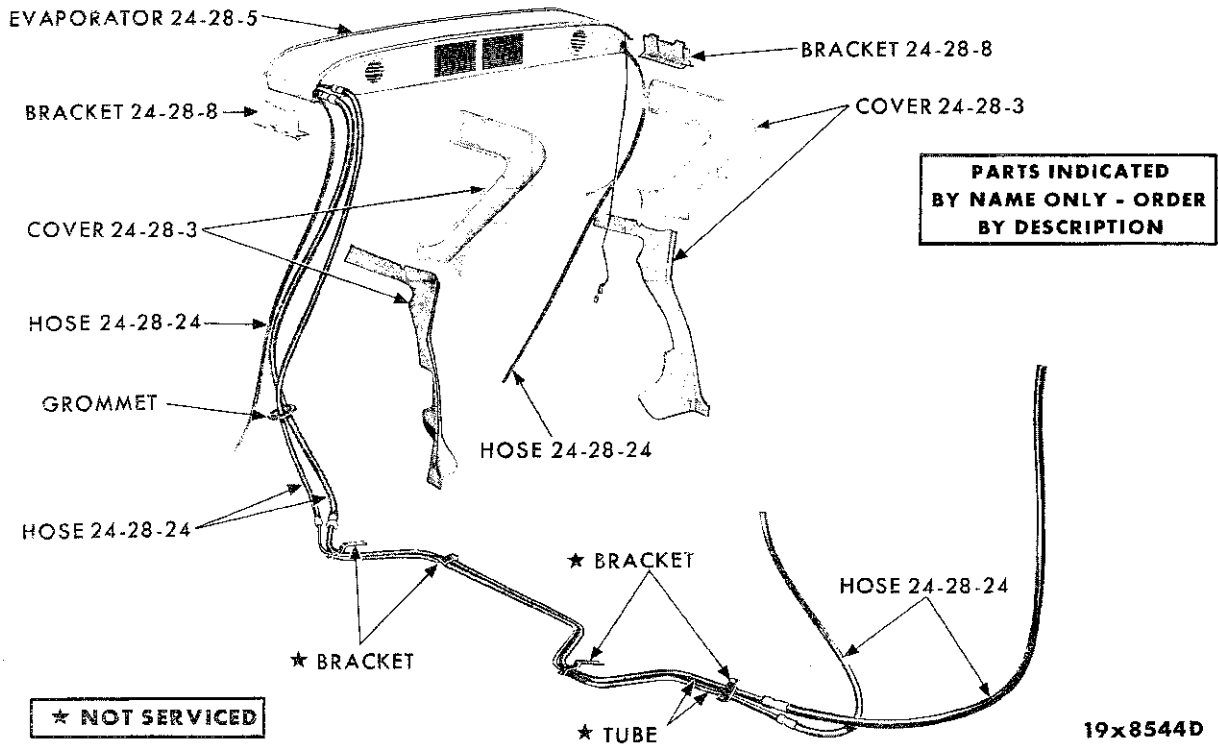

AIR CONDITIONING SYSTEM - SUBURBAN

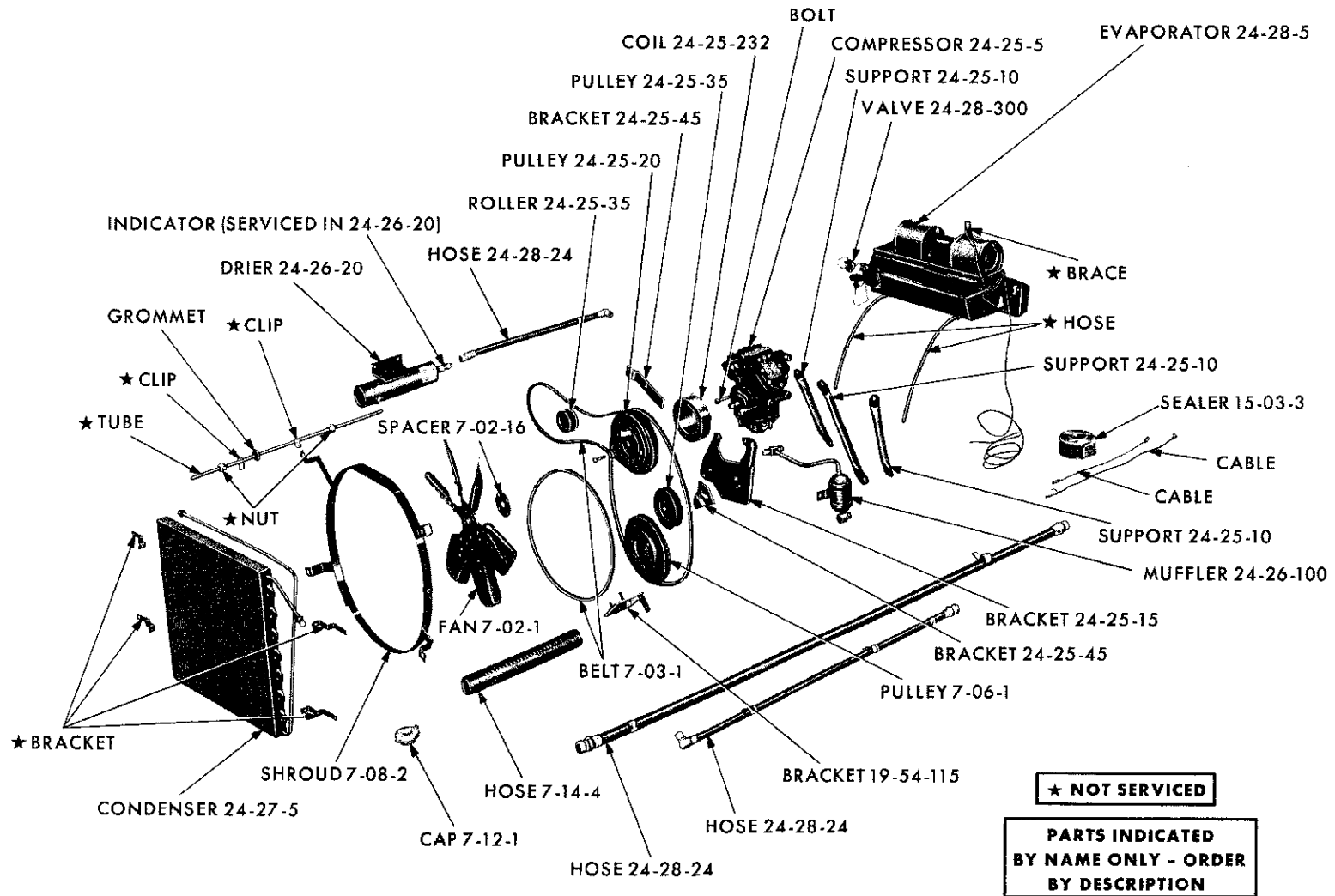

19x9358B

AIR CONDITIONING SYSTEM (6 CYLINDER) - VALIANT SV1 AND LANCER SL1 (MOPAR MODEL "G")

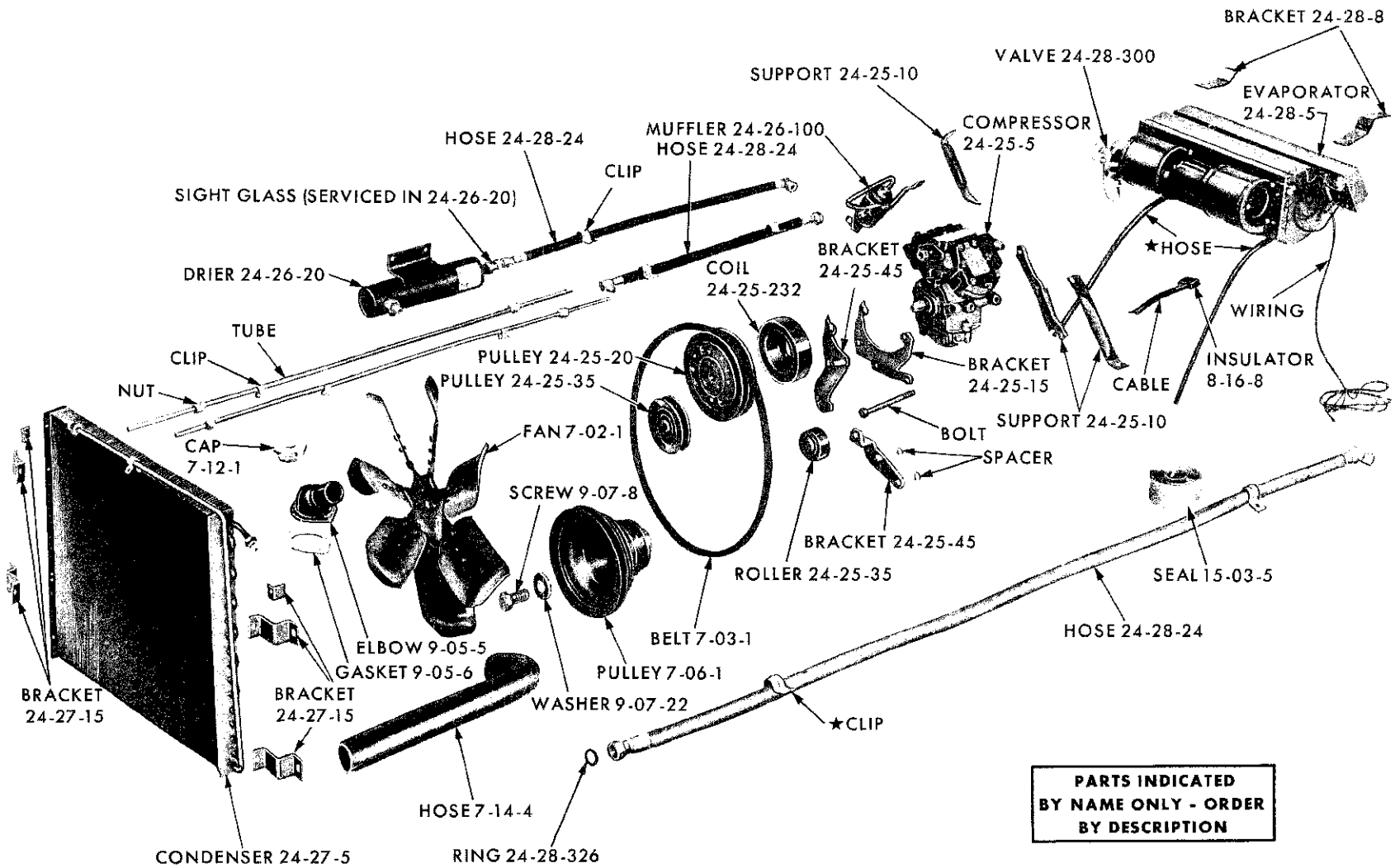

AIR CONDITIONING SYSTEM (V8 CYLINDER) - PLYMOUTH SP1-2 AND DODGE SD1-2 (MOPAR MODEL "G")

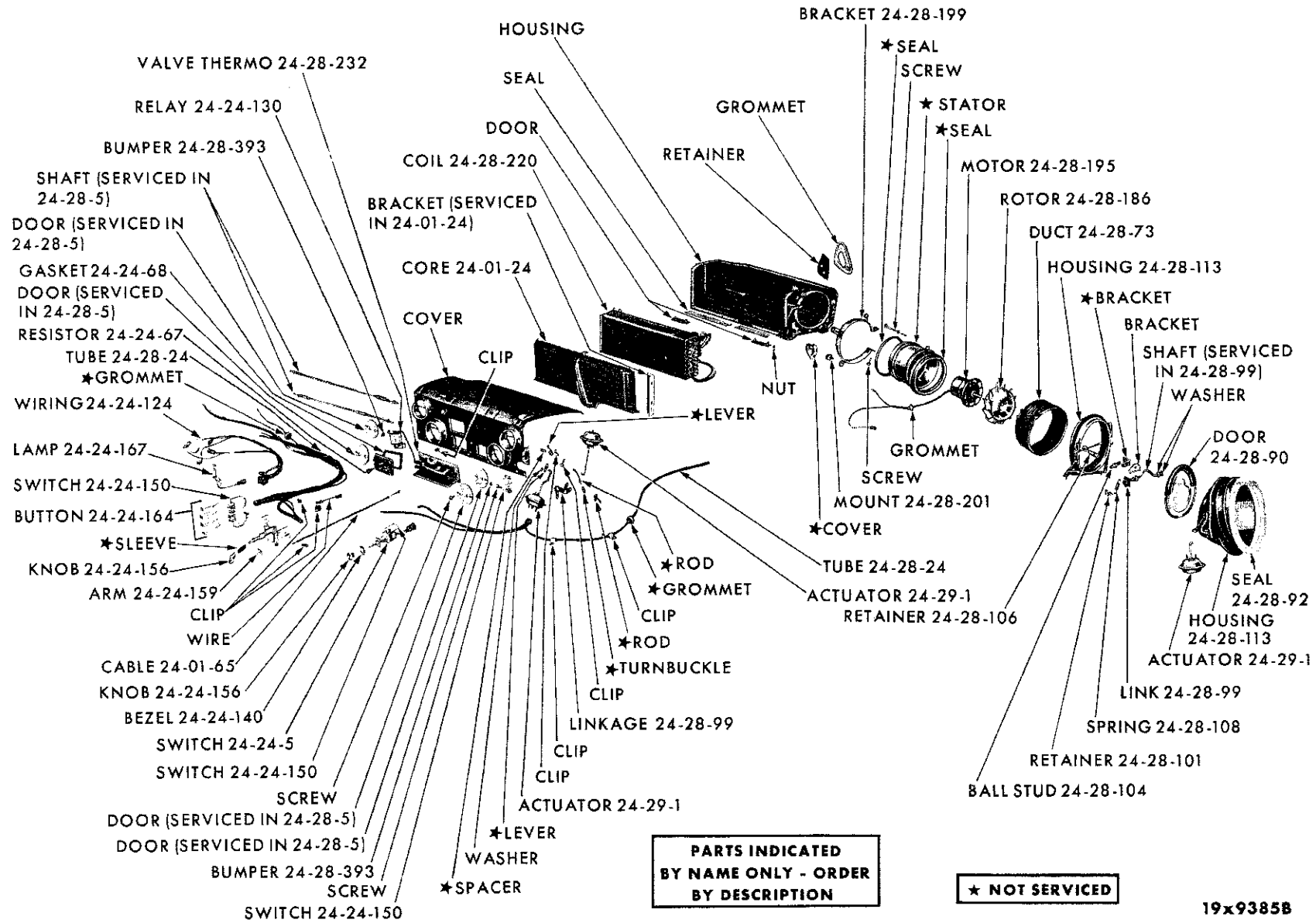

AIR CONDITIONING SYSTEM (COWL TYPE) - PLYMOUTH SP1-2 AND DART SD1-2

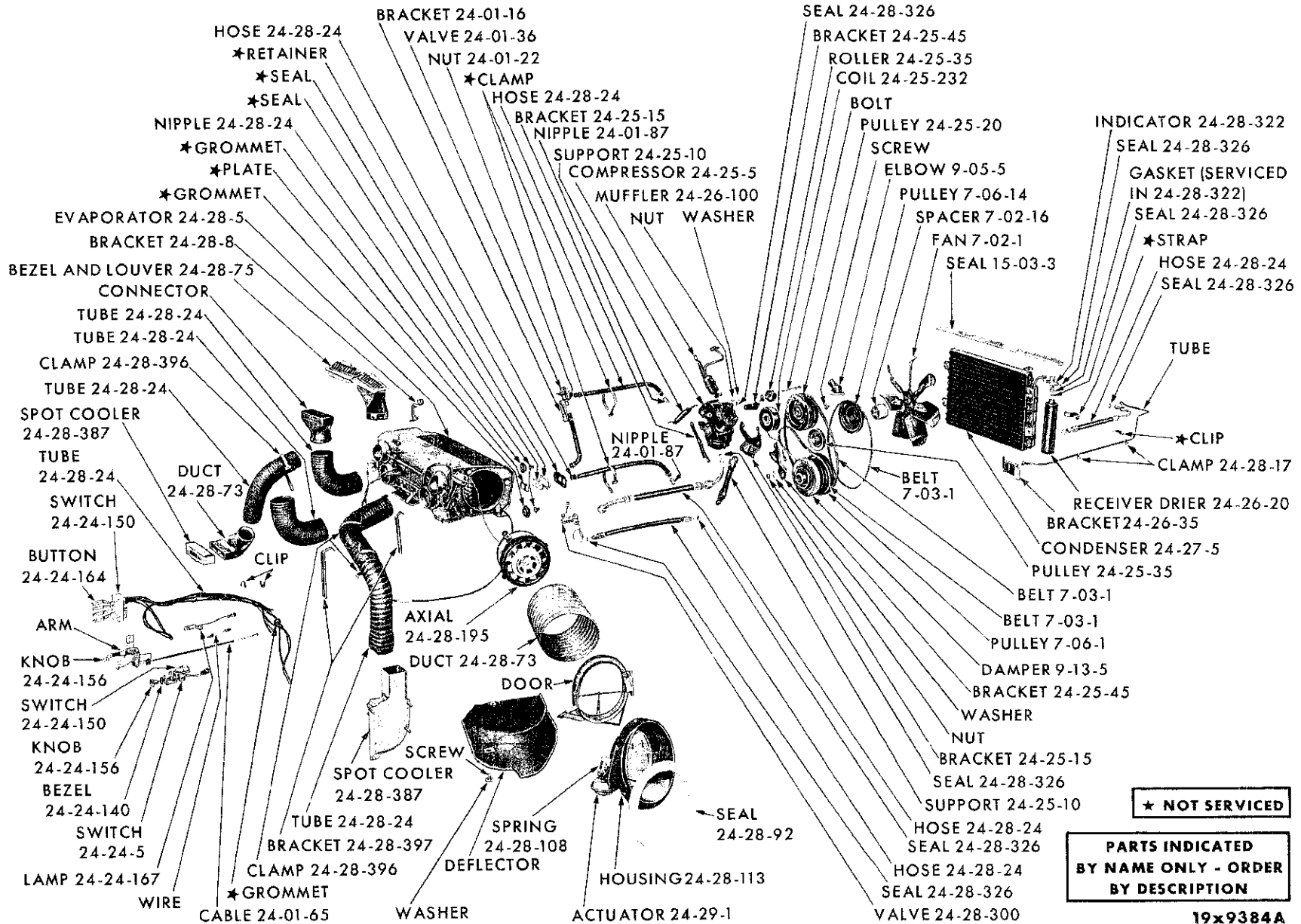

AIR CONDITIONING SYSTEM - PLYMOUTH SP1-2 AND DART SD1-2

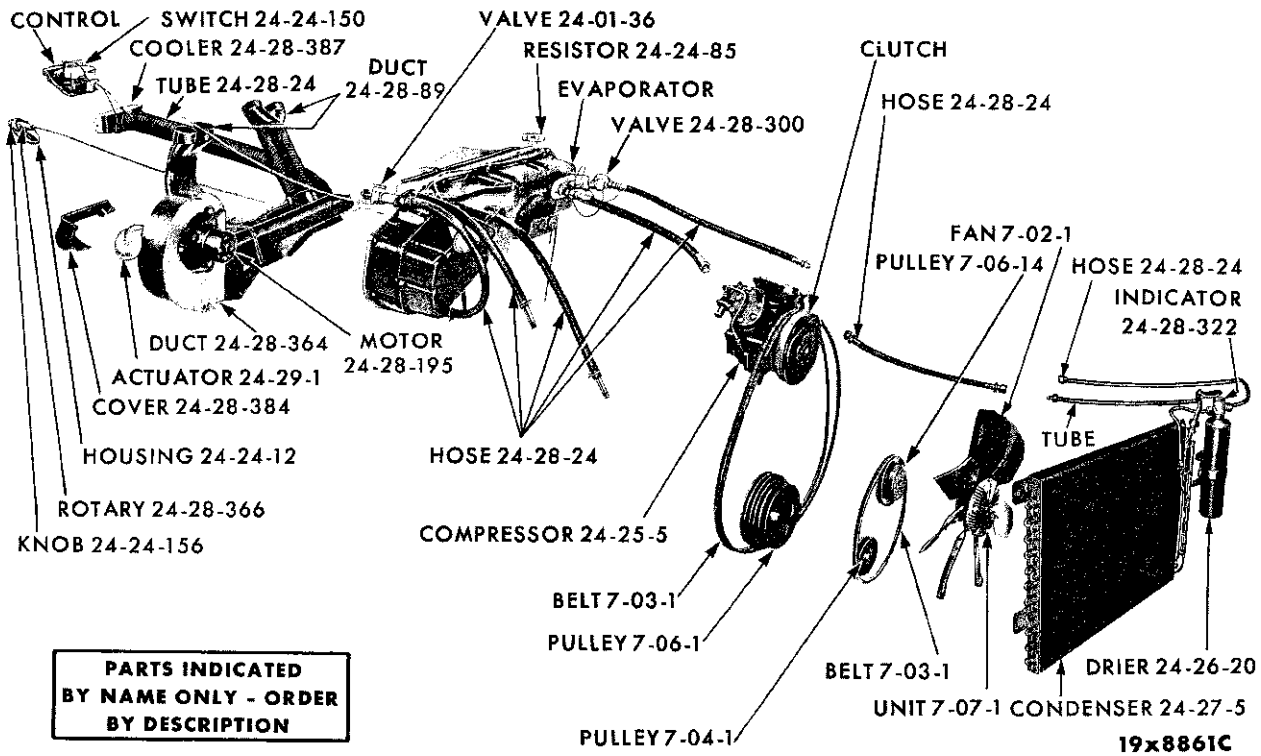

AIR CONDITIONING SYSTEM - CHRYSLER SC1-2-3 AND IMPERIAL SY1

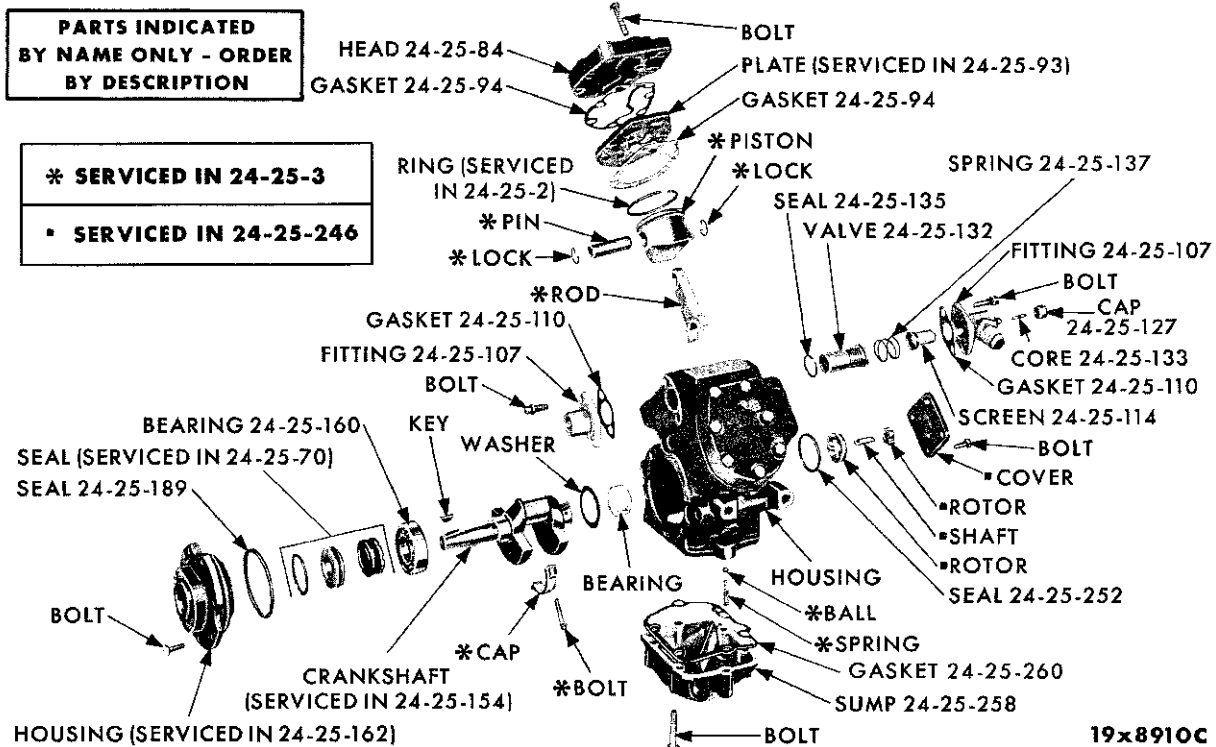

AIR CONDITIONING COMPRESSOR

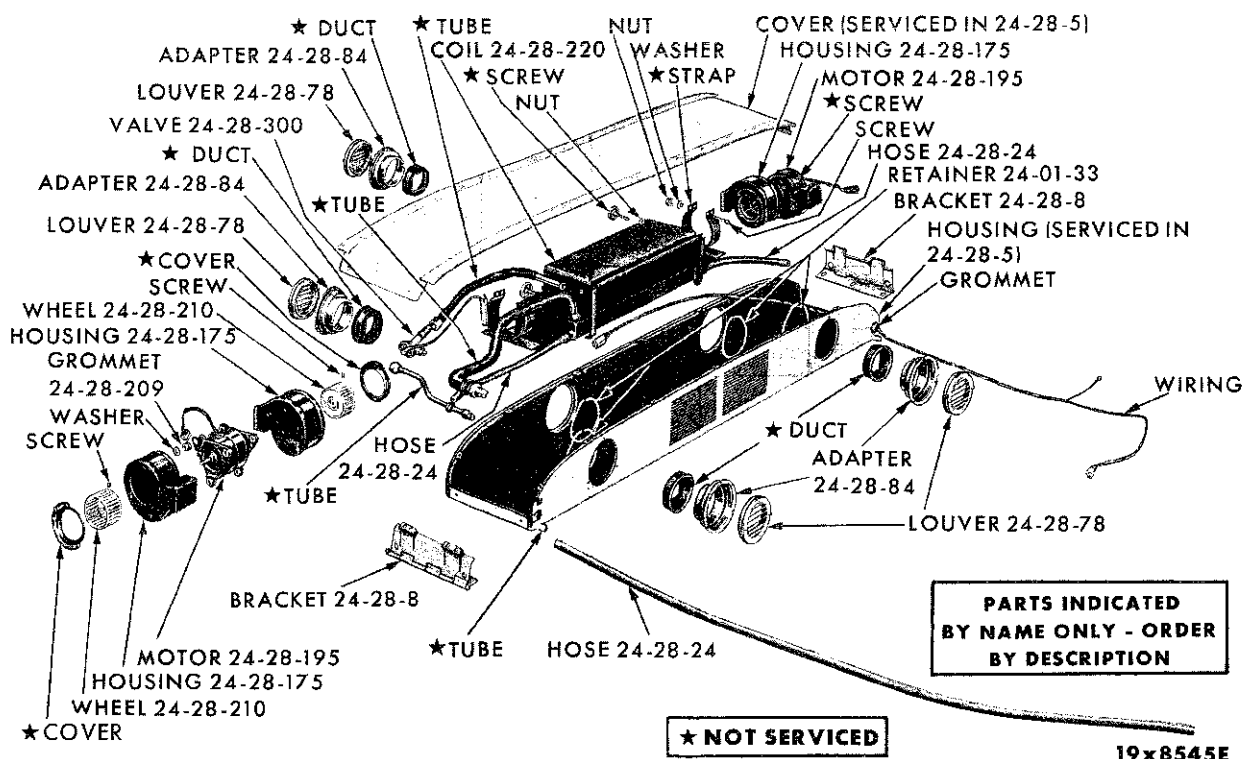

AIR CONDITIONING EVAPORATOR - SUBURBAN

NOTES

(This area contains 16 horizontal lines for notes.)

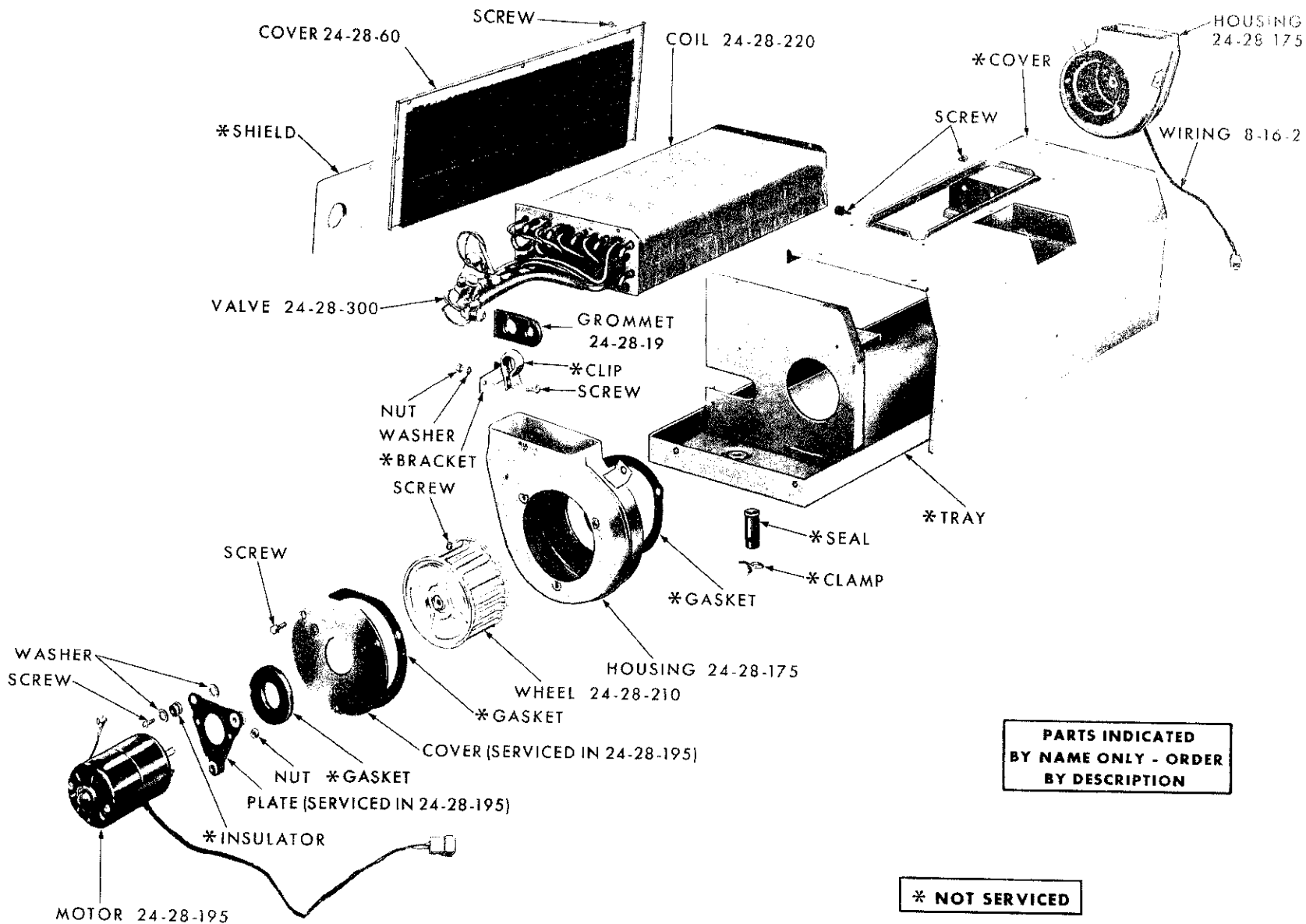

**PARTS INDICATED
BY NAME ONLY - ORDER
BY DESCRIPTION**

*** NOT SERVICED**

AIR CONDITIONING EVAPORATOR - TRUNK TYPE

19x8368C

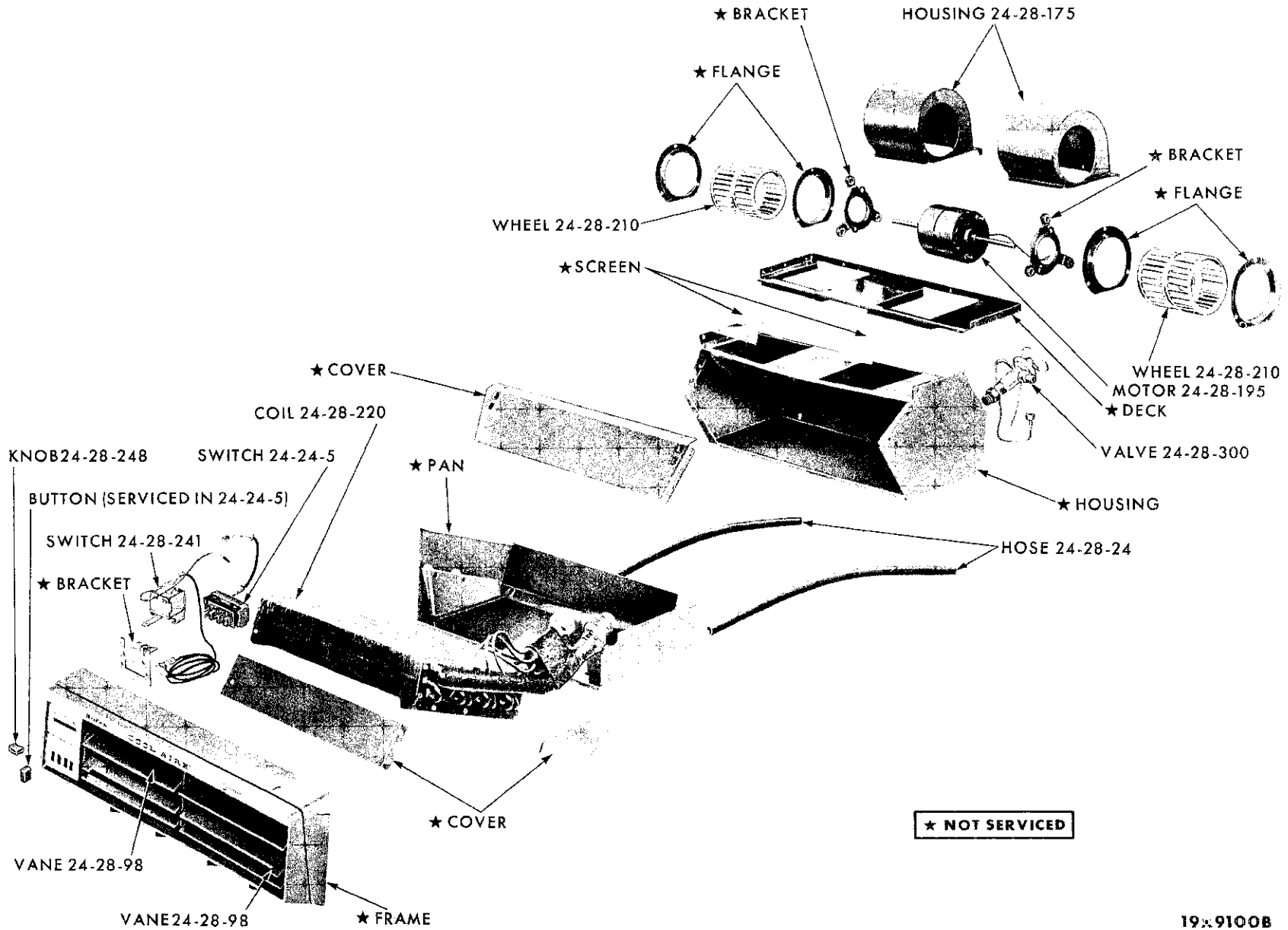

AIR CONDITIONING EVAPORATOR - MOPAR MODEL "G"

19x.9100B

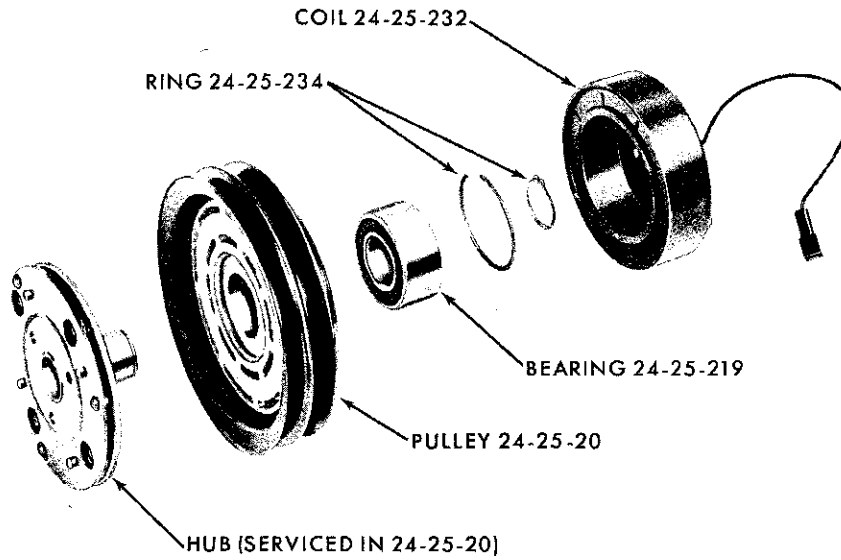

19x9359

AIR CONDITIONING CLUTCH (6 CYLINDER) - EXCEPT CHRYSLER SC1-2-3 AND IMPERIAL SY1

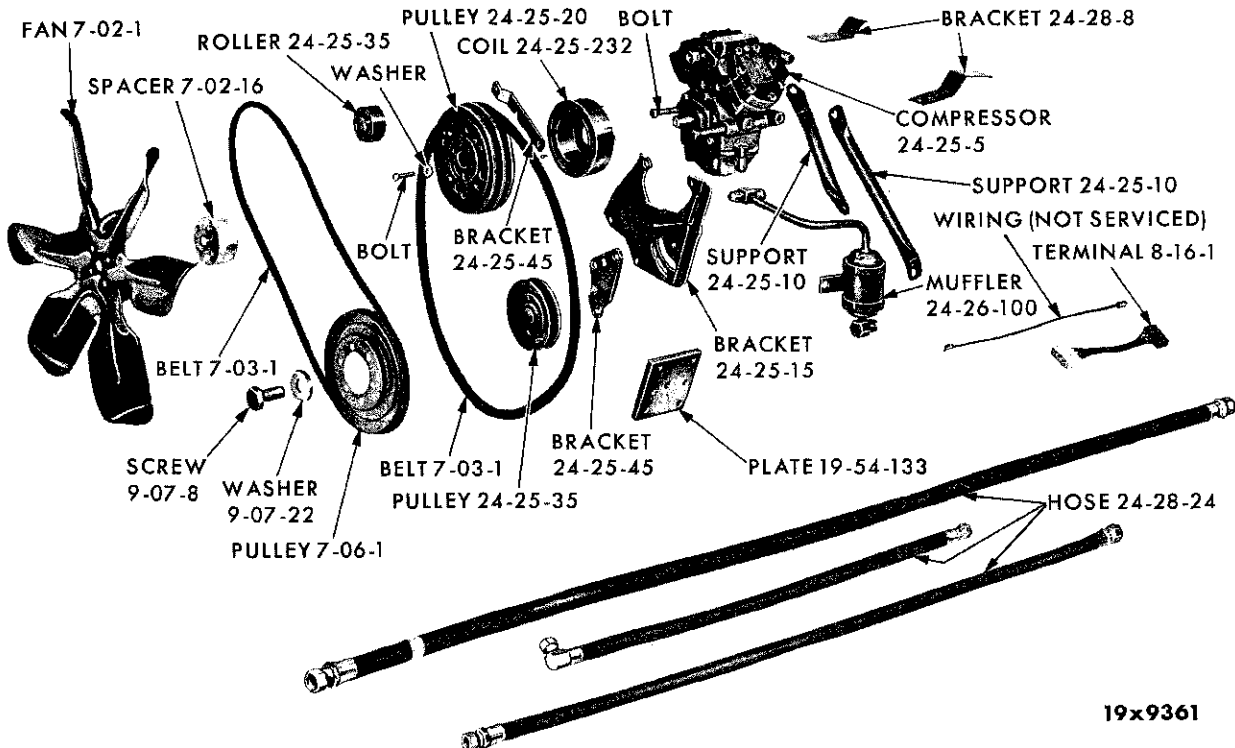

19x9361

AIR CONDITIONING ADAPTER PACKAGE (225 CU. IN.) - PLYMOUTH SP1-2 AND DODGE SD1-2

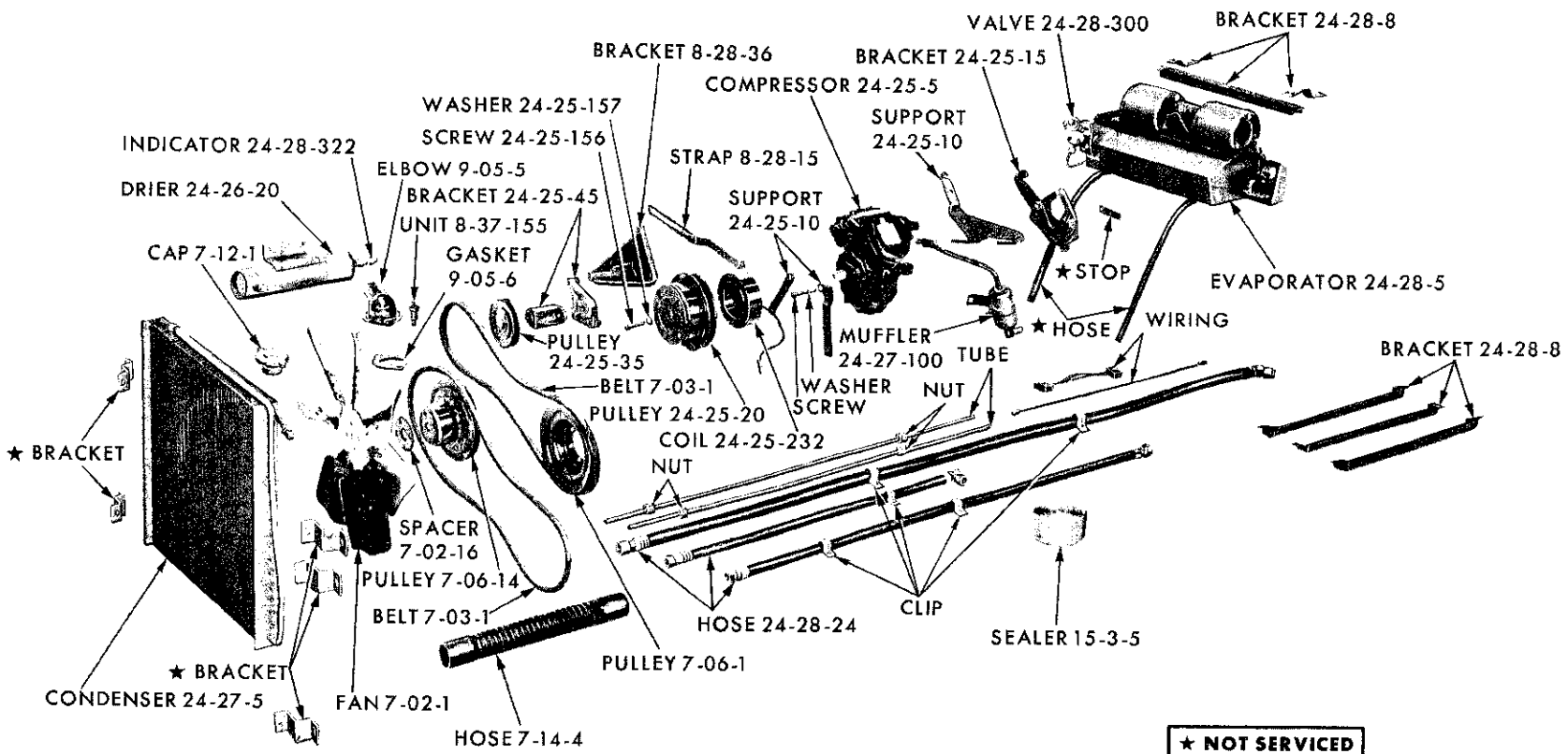









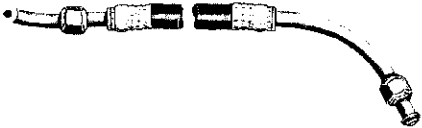

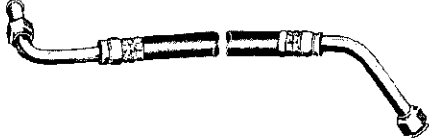

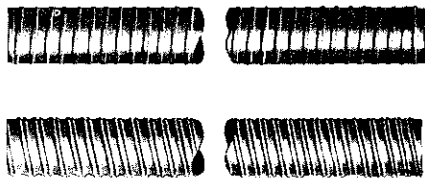

*** NOT SERVICED**

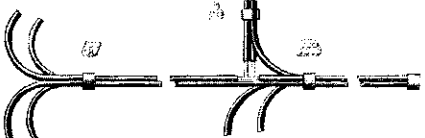
**PARTS INDICATED
 BY NAME ONLY - ORDER
 BY DESCRIPTION**

19x9404

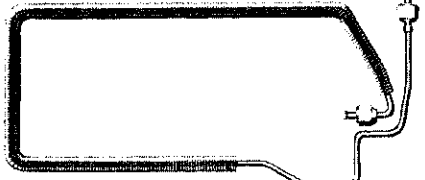
AIR CONDITIONING SYSTEM - MOPAR MODEL "G"

A		I	
B		J	
C		K	
D		L	
E		M	
F		N	
G		O	
H		P	
		Q	

19L9147B

AIR CONDITIONING HOSE CHART

AIR CONDITIONING HOSE CHART

TYPE	PART NUMBER	LENGTH	HOSE OUTSIDE DIA.	THREAD DIAMETER	LOCATION
A	1658 029	38 in.	3/4 in.	5/8-18	SY1, Rear Expansion Valve to Underbody Liquid Tube
	1704 447	94 in.	1 in.	7/8-14	SD3, SC1, Sub. Suction, Rear Unit to Underbody Tube
	1887 254	68 1/2 in.	1 in.	7/8-14	SD3, SC2, SC3, Suction, Rear Unit to Underbody Tube (w/Dual Unit)
	1887 254	68 1/2 in.	1 in.	7/8-14	SY1, Suction, Tee to Underbody Tube (w/Dual Unit)
	2097 052	80 in.	3/4 in.	5/8-18	SC1, SC2, SC3, Rear Expansion Valve to Underbody Liquid Tube
	2097 057	30 in.	1 in.	7/8-14	SY1, Suction, Rear Unit to Underbody Tube (w/Dual Unit)
	2219 127	18 7/8 in.	3/4 in.	3/4-16	SD3, SC1, SC2, SC3, SY1, All, Discharge, Muffler to Condenser Tube
	2219 174	20 in.	3/4 in.	3/4-16	SD3, SC1, SC2, SC3, SY1, Expansion Valve to Liquid Tube
	2277 158	53 in.	1 in.	7/8-14	SD3, SC1, Sub., Suction, Front Tee to Underbody Tube (w/Dual Unit)
	2277 158	53 in.	1 in.	7/8-14	SC2, SC3, Suction, Front Tee to Underbody Tube (w/Dual Unit)
	2277 158	53 in.	1 in.	7/8-14	SC3, Sub. Suction, Tee to Underbody Tube (w/Dual Unit)
	2277 431	23 in.	7/8 in.	3/4-16	SP1, SD1, Discharge, Muffler to Condenser Tube
	2277 431	23 in.	7/8 in.	3/4-16	SP2, SD2, Discharge, Muffler to Condenser Tube w/318 Cu.In.Eng.
	2277 646	19 in.	3/4 in.	5/8-18	SP1, SD1, w/225 Cu.In.Eng., SP2, SD2, w/318 and 361 Cu.In.Eng., Expansion Valve to Liquid Tube
B	1315 466	---	1 in.	---	SP, SD, SC, SY, All Valve to Heater, Heater to Pump (50 Foot Roll)
	2097 131	62 in.	5/8 in.	---	SC1, SC3, Evaporator Drain, Sub.
	2219 706	---	5/8 in.	---	SV1, SL1, Evaporator Drain, Model "G"
	2277 506	10 in.	9/16 in.	---	SP1, SP2, SD1, SD2, Control Tube Vacuum Connector to Thermo
	2405 200	18 in.	9/16 in.	---	SP1, SP2, SD1, SD2, Control Vacuum to Connector
C	1595 160	29 in.	1 in.	---	SD3, SP, SD, SC, SY All, Eng. to Valve (Formed)
	1779 885	12 in.	1 in.	---	SP1, SP2, SD1, SD2, Valve to Heater
	2096 932	46 in.	1 in.	---	SP2, SD2, Core to Pump
	2277 425	50 in.	1 in.	---	SP1, SD1, Core to Pump, w/225 Cu.In.Eng.
D	1998 625	---	---	---	SV1, SL1, SP1, SD1, Suction, Evaporator to Compressor (Model "G")
	2003 761	10 in.	1/2 in.	3/4-16	SP1, SP2, SD1, SD2, SC1, SC2, SC3, SY1, Discharge, Muffler to Condenser (Model "G")
	2006 357	---	---	---	SC2, SC3, SY1, Suction, Evaporator to Compressor (w/Model "G")
	2096 835	23 in.	1 in.	7/8-14	SC1, SC2, SY1, Suction Evaporator to Compressor (w/361 Cu.In.Eng.)
	2096 835	23 in.	1 in.	7/8-14	SD3, SC1, SC2, SY1, Sub., Suction, Front Unit to Tee (w/Dual Unit)
	2096 835	23 in.	1 in.	7/8-14	SD3, SC2, SC3, Suction Compressor to Tee (w/Dual Unit)
E	1658 630	33 in.	3 in.	---	SP1, SP2, SD1, SD3, Distribution Duct to Spot Cooler, Left
	1689 313	52 in.	2 1/4 in.	---	SD3, SC1, SC2, SC3, SY1, Distribution Duct to Spot Cooler
	2197 020	18 in.	3 1/4 in.	---	SC1, SC2, SC3, Distribution Duct to Air Outlet Duct, Left
	2277 415	36 in.	3 in.	---	SP1, SP2, SD1, SD2, Distribution Duct to Spot Cooler, Right
	2277 507	13 in.	3 1/2 in.	---	SP1, SP2, SD1, SD2, Air Outlet
	2279 917	12 1/4 in.	3 1/4 in.	---	SY1, Air Outlet Includes Connector
F	2257 198	---	1/4 in.	---	SD3, SC1, SC2, SC3, SY1, Control, w/Tee and Connector
	2277 228	---	1/4 in.	---	SP1, SD1, SP2, SD2, Vacuum Selector Switch (3 Tubes)
	2426 139	---	1/4 in.	---	SP1, SP2, SD1, SD2, Control, w/Tee and Connector (7 Tubes)
G	2219 214	42 in.	3/4 in.	5/8-18	SD3, SC1, SC2, SC3, Liquid, Front Tee to Underbody Tube
	2219 406	51 in.	3/4 in.	---	SY1, Liquid, Front Tee to Underbody Tube
H	2219 302	---	---	---	SC3, SY1, Liquid, Receiver Drier to Liquid Hose (w/Fins)
I	2277 331	18 1/8 in.	1 5/16 in.	7/8-14	SP2, SD2, Suction Evaporator to Compressor, w/318 Cu.In.Eng.
J	2277 429	33 9/16 in.	1 1/4 in.	7/8-14	SP1, SD1, Suction, Evaporator to Compressor
	2277 429	33 9/16 in.	1 1/4 in.	7/8-14	SP2, SD2, Suction, Evaporator to Compressor (w/361 Cu.In.Eng.)
K	2004 792	21 in.	3/8 in.	5/8-18	SP2, SD2, Discharge, Muffler to Condenser, w/Model "G"
L	2277 665	5 in.	---	---	SP1, SD1, Expansion Valve to Unit (w/Insulation)
M	1887 627	20 in.	3/8 in.	3/4-16	SV1, SL1, Liquid (Model "G")
	2004 759	37 in.	3/8 in.	5/8-18	SV1, SL1, Discharge, Muffler to Condenser (Model "G")
	2006 358	28 in.	3/8 in.	5/8-18	SP1, SP2, SD1, SD2, Liquid, Expansion Valve to Liquid Tube, w/Model "G"
N	2004 790	70 in.	5/8 in.	7/8-14	SP2, SD2, SC1, SC2, Suction, Evaporator to Compressor, w/Model "G"
O	2277 374	18 7/8 in.	3/4 in.	3/4-16	SP2, SD2, Discharge, Muffler to Condenser (w/318 Cu.In.Eng.)
P	2277 470	3/4 in.	3/4 in.	---	SP1, SP2, SD1, SD2, Evaporator Drain
Q	1971 913	6 3/4 in.	1/2 in.	---	SD3, SC1, SC2, SY1, Evaporator Drain

CODE	PART NAME AND DESCRIPTION	CYL.	PER CAR	VALIANT LANCER	PLYMOUTH DODGE	CHRYSLER IMPERIAL
24-01-0 AIR CONDITIONING						
24-01-1	AIR CONDITIONING PACKAGE, Common, Model G		1	----	2298 796	
24-01-5	AIR CONDITIONING ADAPTER PACKAGE, Model G	6	1	----	2298 797	
	w/413 cu. in. Eng.	8	1	----	----	2298 850
24-01-6	CONVERSION PACKAGE, Model G for R Series.	8	1	----	2299 318	
24-01-16	BRACKET, Water Valve Mtg., except SD3		1	----	2277 207	
24-01-18	COVER, Heater Core, SD3	8	1	----	2097 373	2097 373
24-01-22	NUT, Water Valve Bracket, except SD3		1	----	2277 216	
24-01-24	CORE, Heater		1	----	2277 193	1879 904
	SD3	8	1	----	1879 904	
24-01-26	SEAL, Heater Core Tube, SD3		2	----	*1604 116	*1604 116
24-01-33	RETAINER, Air Outlet Louver and Frame, Frt. Unit, SD3	8	4	----	2197 896	2197 896
	Roof Unit, Sub.	8	4	----	----	1689 670
24-01-36	VALVE, Water, except SD3		1	----	2277 123	
	VALVE, Temperature Control, SD3, SC1, SC2, SC3 SY1	8	1	----	1972 779	1972 779
		8	1	----	----	1972 781
24-01-62	NOZZLE, Defroster, SD3	8	1	----	*1971 693	
24-01-65	CABLE, Temperature Control, except SD3		1	----	2291 605	2291 604
	SD3	8	1	----	2291 604	
24-24-0 CONTROL						
24-24-5	SWITCH, Blower, Electrical Rotary, except SD3		1	----	2256 478	
	SD3, SY1 Temperature Control Blower	8	1	----	*2097 970	*2097 970
	Rear Unit, except SY1	8	1	----	----	2084 450
	SY1	8	1	----	----	2197 407
	Rear Unit, Sub.	8	1	----	----	1881 937
	STUD, Blower Switch Housing, except SY1	8	2	----	----	6010 020
	SWITCH, Blower, Model G		1	1998 598	1998 598	1998 598
24-24-8	NUT, Blower Motor Switch, Roof Unit, Sub.		1	----	1971 521	1971 521
24-24-10	CAM, Vacuum Switch Control, except SD3		1	----	*2258 093	
24-24-12	HOUSING, Blower Switch Rear Unit, also Floor Damper Control, SD3	8	★	----	2291 149	2291 149
24-24-13	NAME PLATE, Blower Switch, Rear Unit, SY1	8	1	----	----	2197 509
24-24-20	KNOB, Blower Switch, SP1, SP2		1	----	2256 479	
	SD1, SD2		1	----	2256 483	
	Rear Unit, except SY1	8	1	----	----	2257 955
24-24-23	PACKAGE, Blower Switch Adapter, SD3, SY1	8	1	----	2196 336	2196 336
24-24-27	COVER, Floor Air Control Switch Mtg. Hole, SY1	8	1	----	----	2198 082
24-24-29	DECAL, Blower Switch, SP1, SP2		1	----	2258 263	
	SD1, SD2		1	----	2258 625	

★ Indicates use as required.
 □ Indicates parts not listed in any previous parts book.
 * Indicates change or addition.

Printed in U.S.A.
 Prices and specifications subject to change without notice.
 March 8, 1963 Supersedes May 1, 1962

1962 PASSENGER CAR PARTS CATALOG

AIR CONDITIONING

CODE	PART NAME AND DESCRIPTION	C Y L	PER CAR	VALIANT LANCER	PLYMOUTH DODGE	CHRYSLER IMPERIAL
24-24-O CONTROL - Cont'd						
24-24-32	CLIP, Vacuum Switch Hose Connector Retaining . . .		1	----	2257 848	
24-24-67	RESISTOR, Blower Motor, except SD3		1	----	2277 187	
24-24-68	GASKET, Blower Motor Resistor, except SD3 . . .		1	----	2277 454	
24-24-85	BLOCK, Resistor, w/BRACKET, SD3	8	1	----	1972 049	1972 049
	BLOCK, Resistor, SD3	8	1	----	2258 815	2258 815
24-24-112	BEZEL PACKAGE, except SY1	8	1	----	----	2084 054
24-24-124	WIRING, Harness, Air Conditioning, SP1, SP2 . . .		1	----	2258 825	
	Harness, SD1, SD2		1	----	2290 334	
	SD3		1	----	2426 154	
24-24-130	RELAY, Blower Motor, except SD3		1	----	2277 478	
24-24-137	NUT, Blower Motor Switch, except SD3		1	----	1339 711	
	Rear Unit, except SY1	8	1	----	----	1971 521
24-24-140	BEZEL, Floor Damper Control, Switch Title, except SY1	8	1	----	----	1972 488
	SY1	8	1	----	----	2197 663
	Blower Motor Switch, except SY1		1	----	2256 616	1972 487
	Control, except SY1		1	----	----	*1971 938
24-24-150	SWITCH, Push Button Vacuum, except SD3		1	----	2256 396	2096 084
	SD3	8	1	----	2096 083	
	Aux. Vacuum, on Electric Switch, 4 Leads . . .		1	----	2257 452	
	SCREW, Vacuum Switch Mtg.		★	----	6006 036	6006 036
	Temperature Selector, on Evaporator, 3 Leads . .		1	----	2277 194	
	Aux. Vacuum, w/BRACKET and SLEEVE, 4 Leads .		1	----	2258 096	
24-24-156	KNOB, Temperature Control, SP1, SP2		1	----	2258 166	
	SD1, SD2		1	----	2258 359	
	Except SY1		1	----	----	1972 499
	SY1		1	----	----	2197 844
	SD3	8	1	----	2197 623	
	Damper Control, except SY1		1	----	----	2257 955
	SY1		1	----	----	1887 935
	SD3	8	1	----	2257 478	
24-24-159	PLATE, Temperature Control, SD3, SC1, SC2, SC3 SY1		1	----	2197 466	2097 100
	SD1, SD2		1	----	2258 342	2197 839
	SP1, SP2		1	*2258 161		
24-24-161	CONTROL, Push Button, w/BUTTONS, Plate and Vacuum Switch, SP1, SP2		1	----	2258 170	
24-24-164	EXTENSION, Push Button					
	SP1, SP2 Off		1	----	2258 171	
	SP1, SP2 Heat		1	----	2258 172	
	SP1, SP2 Defroster		1	----	2258 173	
	SP1, SP2 Cool		1	----	2258 174	
	SD1, SD2 Off		1	----	2258 348	
	SD1, SD2 Heat		1	----	2258 349	
	SD1, SD2 Defroster		1	----	2258 350	
	SD1, SD2 Cool		1	----	2258 351	
	SD3 Fresh Cool	8	1	----	2197 474	
	SD3 Max. Cool	8	1	----	2197 473	
	SD3 Heat	8	1	----	2197 475	
	SD3 Defroster	8	1	----	2197 471	
	SD3 Off	8	1	----	2197 468	
	Except SY1 Off	8	1	----	----	1887 667
	SY1 Off	8	1	----	----	2197 846
	Except SY1 Heat	8	1	----	----	1887 674

★ Indicates use as required.

⊠ Indicates parts not listed in any previous parts book.

March 8, 1963 Supersedes May 1, 1962.

Printed in U.S.A.

Prices and specifications subject to change without notice.

* Indicates change or addition.

CODE	PART NAME AND DESCRIPTION	CYL.	PER CAR	VALIANT LANCER	PLYMOUTH DODGE	CHRYSLER IMPERIAL
24-24-O CONTROL - Cont'd						
24-24-164	EXTENSION - Cont'd					
	Except SY1 Heat	8	1	----	-----	2197 853
	Except SY1 Defroster	8	1	----	----	1887 670
	SY1 Defroster	8	1	----	----	2197 849
	Except SY1 Max. Cool	8	1	----	----	1887 672
	SY1 Max. Cool	8	1	----	----	2197 851
	Except SY1 Fresh Cool	8	1	----	----	1887 673
	SY1 Fresh Cool	8	1	----	----	2197 852
	Except SY1 Air	8	1	----	----	1887 671
	SY1 Air	8	1	----	----	2197 850
24-24-165	SLEEVE, Control Arm, SY1	8	1	----	----	2097 942
24-24-167	SOCKET, Control Lamp, includes HOOD and BRACKET, SP1, SP2, SC1, SC2, SC3	8	1	----	2197 001	2197 001
	LAMP, w/CABLE, Air Conditioning Control, SY1	8	1	----	----	2197 832
24-24-170	PAD, Push Button Control	8	1	----	----	2080 388
24-25-O COMPRESSOR						
	NOTE: For Compressor and Generator Belt See Part Type Code 7-03-1.					
24-25-2	PISTON RING PACKAGE		1	2275 207	2275 207	2275 207
24-25-3	PISTON and CONNECTING ROD PACKAGE		1	2275 203	2275 203	2275 203
24-25-5	COMPRESSOR		1	2002 768	2002 768	2002 768
24-25-10	SUPPORT, Compressor, w/225 cu. in. Eng., Right Rear	6	1	2264 867	2264 867	
	Right, w/170 cu. in. Eng.	6	1	2264 868	2264 868	
	Right, w/318 cu. in. Eng.	8	1	----	2264 219	
	Left, w/318 cu. in. Eng.	8	1	----	2264 218	
	Left, Front, Model G	8	1	----	1993 725	1993 725
	SUPPORT, Compressor, Front, SP2, SD2, SD3, SC1, w/361 cu. in. Eng., SC2, w/383, 413 cu. in. Eng., SC3, SY1	8	1	----	1947 657	1947 657
24-25-15	BRACKET, Compressor Mtg., w/225 cu. in. Eng.	6	1	----	2264 865	
	w/318 cu. in. Eng.	8	1	----	2264 215	
	w/361, 383 cu. in. Eng.	8	1	----	1852 932	1852 932
	w/413 cu. in. Eng.	8	1	----	----	1858 622
	BRACKET, Compressor Steady, w/361 cu. in. Eng., SP2, SD2	8	1	----	2264 652	
	w/361, 383 cu. in. Eng., SD3	8	1	----	1852 933	1852 933
	w/413 cu. in. Eng.	8	1	----	----	1858 620
	BRACKET, Compressor Steady, Side, w/361, 383 cu. in. Eng.	8	1	----	2128 969	2128 969
	BRACKET, Compressor, Rear, w/318 cu. in. Eng.	8	1	----	2264 217	
	BRACKET, Compressor Mtg., Model G, except SD3 w/361 cu. in. Eng., Model G, SD3	6	1	2003 062	2264 865	
	w/413 cu. in. Eng., Model G	8	1	----	1999 185	1999 185
	BRACKET, Compressor Steady, w/361 cu. in. Eng., Model G	8	1	----	----	2003 103
	Eng., Model G	8	1	----	2003 056	2003 056
	w/413 cu. in. Eng., Model G	8	1	----	----	2003 104
	BRACKET, Steady Side, w/413 cu. in. Eng.	8	1	----	----	2128 970
24-25-20	PULLEY, w/HUB, SV1, SL1, SP1, SD1, Double Groove SP2, SD2, w/318 cu. in. Eng., 6 1/2" dia., Stamping, Single Groove	6	1	2219 613	2219 613	
	SP2, SD2, w/318 cu. in. Eng., 7 1/4" dia., Cast Iron, Single Groove	8	1	----	2277 378	
	SP2, SD2, w/318 cu. in. Eng., 7 1/4" dia., Cast Iron, Single Groove	8	1	----	2277 790	
	SP2, SD2, SD3, 6 1/2" O.D. Single Groove	8	1	----	*2003 058	*2003 058

★ Indicates use as required.
 □ Indicates parts not listed in any previous parts book.
 * Indicates change or addition

Printed in U.S.A.
 Prices and specifications subject to change without notice.
 March 8, 1963 Supersedes May 1, 1962.

1962 PASSENGER CAR PARTS CATALOG

AIR CONDITIONING

CODE	PART NAME AND DESCRIPTION	CYL	PER CAR	VALIANT LANCER	PLYMOUTH DODGE	CHRYSLER IMPERIAL
24-25-0 COMPRESSOR - Cont'd						
24-25-20	PULLEY, w/HUB - Cont'd SP2, SD2, SD3, 6 1/4" O.D., Double Groove . . .	8	1	----	*2097 106	*2097 106
	SP2, SD2, w/318 cu. in. Eng., 6 3/4" O.D., Stamped 2006 396	8	1	----	2006 396	
24-25-26	NUT, w/WASHER, Idler Pulley Adjusting		1	----	1740 972	1740 972
24-25-35	PULLEY, Compressor Idler, SP1, SD1, w/225 cu. in. Eng., SP2, SD2, w/318 cu. in. Eng. . . .		1	2203 031	2203 031	
	PULLEY, Compressor Idler, SP2, SD2, SD3, w/361 cu. in. Eng.	8	1	----	2004 766	2004 766
	ROLLER, Compressor Idler, SP2, SD2, w/318 cu. in. Eng., SV1, SL1, SP1, SD1, w/225 cu. in. Eng.		1	2206 022	2206 022	
	ROLLER, SV1, SL1, w/170 cu. in. Eng.		1	2006 374	2006 374	
24-25-45	BRACKET, Idler Roller	6	1	2006 375	2264 871	
	Idler Pulley Adjusting	6	1	2003 060	2203 035	
	Idler Roller	8	1	----	2264 555	
	Idler Pulley, w/318 cu. in. Eng.	8	1	----	2264 221	
	Idler Pulley Adjusting, SP2, SD2, SD3, w/361 cu. in. Eng.	8	1	----	2004 767	2004 767
	Idler Pulley Mtg., SD3	8	1	----	1999 182	1999 182
	Idler Roller	6	1	2006 375		
24-25-60	GASKET, Oil Sump		1	1377 825	1377 825	1377 825
24-25-70	SEAL PACKAGE, Crankshaft, Gas		1	1426 501	1426 501	1426 501
24-25-84	HEAD, Cylinder, Right.		1	2000 083	2000 083	2000 083
	Left		1	1999 502	1999 502	1999 502
24-25-93	VALVE PLATE PACKAGE, Right		1	2275 204	2275 204	2275 204
	Left		1	2275 205	2275 205	2275 205
24-25-94	GASKET, Cylinder Head		2	1990 584	1990 584	1990 584
	Valve Plate		2	1990 598	1990 598	1990 598
24-25-107	FITTING, Discharge Service for Compressor 2002772 and 2264823		1	1997 449	1997 449	2421 812
	For Compressor 2264824 and 2264 825		1	----	2421 813	2202 740
	FITTING, Suction Service for Compressor 2264823 . For Compressor 2264824 and 2264825		1	----	1997 448	1997 448
	For Compressor 2002772		1	----	2002 739	2002 739
	FITTING, Suction for Compressor 2402 276		1	2003 099	2003 099	2003 099
	FITTING, Suction for Compressor 2402 230	8	1	----	----	2007 102
		8	1	----	2007 168	
24-25-110	GASKET, Compressor Suction Fitting		1	----	1997 446	1997 446
	Discharge Fitting		1	----	1994 406	1994 406
24-25-114	SCREEN, Suction		1	1996 845	1996 845	1996 845
24-25-127	CAP, Compressor Gage Fitting		1	1989 202	1989 202	1989 202
24-25-132	VALVE, Pressure Regulator		1	2275 202	2275 202	2275 202
24-25-133	CORE, Gage Fitting		1	1992 947	1992 947	1992 947
24-25-135	SEAL, Pressure Regulator Valve 7/8" O.D. . . .		1	*1994 410	*1994 410	*1994 410
	SEAL, Discharge Port Fitting 1" I.D.		1	----	*2008 388	*2008 388
24-25-137	SPRING, Regulator Valve Spacer		1	----	*1994 408	*1994 408
24-25-154	CRANKSHAFT PACKAGE		1	2275 206	2275 206	2275 206

★ Indicates use as required.
 □ Indicates parts not listed in any previous parts book.
 March 8, 1963 Supersedes May 1, 1962.

Printed in U.S.A.
 Prices and specifications subject to change without notice.
 * Indicates change or addition.

CODE	PART NAME AND DESCRIPTION	CYL.	PER CAR	VALIANT LANCER	PLYMOUTH DODGE	CHRYSLER IMPERIAL
24-25-O COMPRESSOR - Cont'd						
24-25-156	SCREW, Clutch Pulley Mtg.		1	1658 638	1658 638	1658 638
24-25-157	WASHER, Clutch Pulley Mtg.		1	2097 102	2097 102	2097 102
24-25-160	BEARING, Crankshaft, Ball		1	1854 829	1854 829	1854 829
24-25-162	HOUSING PACKAGE, Front Bearing		1	2196 315	2196 315	2196 315
24-25-189	SEAL, Crankshaft Bearing Housing, Front		1	1377 831	1377 831	1377 831
24-25-219	BEARING, Clutch		1	1769 318	1769 318	1769 318
24-25-232	COIL, Clutch Field. w/318 cu. in. Eng., w/Pulley Stamped 2006 396.	8	1 1	2097 105 ----	2097 105 2006 395	2097 105
24-25-234	RING, Clutch, External Clutch, Internal		1 1	2097 101 2097 103	2097 101 2097 103	2097 101 2097 103
24-25-246	OIL PUMP PACKAGE		1	2196 306	2196 306	2196 306
24-25-252	SEAL, Oil Pump Cover		1	1747 988	1747 988	1747 988
24-25-258	SUMP, Oil		1	1747 962	1747 962	1747 962
24-25-260	GASKET, Oil Sump		1	1377 825	1377 825	1377 825
24-26-O RECEIVER DRIER						
24-26-20	RECEIVER DRIER PACKAGE w/Model G w/Model G		1 1 1	---- 1998 644 ----	1880 658 1742 766	1880 658 1742 766
24-26-21	SCREW, Drier Mtg.		2	9414 721	9414 721	9414 721
24-26-26	PLUG, Fusible Metal		1	1998 645	1744 767	
24-26-35	BRACKET, Receiver Drier Mtg., SD3		1	----	*2219 155	*2219 155
24-26-100	MUFFLER, Compressor, Model G Suction, SP2, SD2, w/318 cu. in. Eng. Model G Suction, SP1, SD1, w/225 cu. in. Eng., SP2, SD2, w/361 cu. in. Eng. Suction, SP2, SD2, w/318 cu. in. Eng. Suction, SD3, SC1, W361 cu. in. Eng. SC2, SC3, SY1, w/Single Unit Suction, SC1, SC2, SC3, SY1, w/Dual Unit	6 8 8 8 8	1 1 1 1 1	2004 756 ---- ---- ---- ----	2004 756 *2004 773 *2277 792 *2277 797 *2277 795 ----	
	Discharge, SP1, SD1, w/225 cu. in. Eng. SP2, SD2, w/361 cu. in. Eng.		1	----	*2277 432	
	Discharge, SP2, SD2, w/318 cu. in. Eng., w/6 1/2" Tube lgh.	8	1	----	*2277 826	
	Discharge, SP2, SD2, w/318 cu. in. Eng., w/8" Tube lgh., w/TEE	8	1	----	*2277 386	
	Discharge, SD3, SC1, SC2, w/361 cu. in. Eng. SC2, SC3, SY1	8	1	----	*2219 549	*2219 549

★ Indicates use as required.
 ☐ Indicates parts not listed in any previous parts book.
 * Indicates change or addition.

Printed in U.S.A.
 Prices and specifications subject to change without notice.
 March 8, 1963 Supersedes May 1, 1962.

1962 PASSENGER CAR PARTS CATALOG

AIR CONDITIONING

CODE	PART NAME AND DESCRIPTION	C Y L.	PER CAR	VALIANT LANCER	PLYMOUTH DODGE	CHRYSLER IMPERIAL
24-27-O CONDENSER						
24-27-5	CONDENSER, except SD3	8	1	----	2219 729	1904 224
	SD3	8	1	----	1904 224	
	Model G	6	1	2004 747		
	Model G	6	1	----	2004 754	2004 754
	SCREW, w/WASHER	8	4	----	----	6022 506
	J/NUT	8	4	----	----	6010 006
24-27-10	SCREW, Condenser Mtg. Bracket, Model G		4	1740 029	1740 029	1740 029
24-28-O EVAPORATOR						
24-28-3	COVER, Lock Pillar Hose, Sub., Color Frost					
	Upper, Right	8	1	----	----	2172 825
	Upper, Left	8	1	----	----	2172 826
	Lower, Right	8	1	----	----	2172 827
	Lower, Left	8	1	----	----	2172 828
	Color Red, Upper, Right	8	1	----	----	2177 175
	Upper, Left	8	1	----	----	2177 176
	Lower, Right	8	1	----	----	2177 189
	Lower, Left	8	1	----	----	2177 190
	Color Cocoa, SC1, SC3, Upper, Right	8	1	----	----	2178 613
	SC1, SC3, Upper, Left	8	1	----	----	2178 614
	SC1, SC2, Lower, Right	8	1	----	----	2178 615
	SC1, SC2, Lower, Left	8	1	----	----	2178 616
24-28-5	EVAPORATOR, SP1, SP2, SD1, SD2		1	----	*2219 826	
	Roof Unit	8	1	----	----	1886 232
	Model G, w/VALVE	6	1	1999 150		
	Model G, w/o Valve	6	1	2003 057	2206 388	2003 057
24-28-8	BRACKET, Evaporator Mtg., Frt. Unit		1	----	2277 209	
	Evaporator Mtg., Roof Unit, Sub.		4	----	----	1971 956
	BRACKET, Evaporator Mtg., Model G	6	1	1998 633		
	Right, Model G, except SD3		1	----	*2003 095	
	Left, Model G, except SD3		1	----	*2003 063	
	SD3	8	1	----	*2013 028	
	Except SY1, Model G	8	1	----	----	1993 677
	SY1, Model G	8	1	----	----	1993 674
24-28-17	CLAMP, Discharge Tube to Yoke		1	----	*2277 430	
24-28-19	GROMMET, Suction Tube, Rear Unit		1	----	----	1658 766
	3/8" Tubing		★	----	2006 394	
	Vacuum Feed Tube		1	*1886 101	*1886 101	*1886 101
	Blower Motor Mtg. SD3	8	1	----	*1879 827	*1879 827
	3/8" Tubing		★	----	*2006 394	
24-28-22	SCREW, Evaporator Mtg., except SD3		1	1983 786	1740 029	6015 014
	SD3		1	----	6015 014	
24-28-24	HOSE and REFRIGERANT TUBE					
	Note: For Refrigerant Hose see Chart in Front of Group 24.					
	TUBE, Copper, 25 ft. Roll, 1/4" dia.		★	1556 710	1556 710	1556 710
	3/8" dia.		★	1638 010	1638 010	1638 010
	1/2" dia.		★	1556 712	1556 712	1556 712
	5/16" dia.		★	1556 711	1556 711	1556 711
	5/8" dia.		★	1556 713	1556 713	1556 713
	TUBE, Discharge, 76" lgh., 1/2" O.D., except SD3		1	----	2277 836	
	TUBE, Liquid, 45" lgh., 3/8" O.D., except SD3		1	----	2277 835	
24-28-25	HOUSING, Evaporator Coil, w/LINKAGE, Front					
	Unit, Rear, SD3	8	1	----	2097 376	2097 376
	HOUSING, Evaporator Coil, w/LINKS, Front					
	Unit, Center, SD3	8	1	----	2096 259	2096 259

★ Indicates use as required.

□ Indicates parts not listed in any previous parts book.

March 8, 1963 Supersedes May 1, 1962.

Page 24-10

Printed in U.S.A.

Prices and specifications subject to change without notice.

* Indicates change or addition.

CODE	PART NAME AND DESCRIPTION	CYL	PER CAR	VALIANT LANCER	PLYMOUTH DODGE	CHRYSLER IMPERIAL
24-28-O EVAPORATOR - Cont'd						
24-28-26	CONNECTOR, Control Hose, "Y", Plastic, except SD3	8	1	----	2277 713	
	1" lgh. 1/8" I.D.		★	----	⊠2485 019	
	1" lgh. 3/14" I.D.		★	----	⊠2485 020	
24-28-31	GASKET, Evaporator to Dash, SD3	8	1	----	*1887 257	*1887 257
24-28-33	FLANGE, Rear Outlet Housing Mtg., w/GASKET	8	2	----	----	2096 681
24-28-36	WASHER, Suction Hose Seal, SD3	8	★	----	2096 887	2096 887
	Liquid Hose Seal, SD3	8	★	----	2219 169	2219 169
	WASHER PACKAGE, Refrigerant Hose, Seal, Copper		★	----	*2196 341	*2196 341
24-28-47	TROUGH, Evaporator Drain, SD3	8	1	----	2096 182	2096 182
24-28-48	SWIVEL, Defroster Door Lever, SD3	8	1	----	1972 789	1972 789
24-28-53	DUCT, Defroster Outlet	6	1	1998 604		
24-28-55	CONNECTOR, Distribution Duct, Outlet, Rubber, SD3	8	1	----	2096 024	2096 024
	SD3, Defroster Outlet	8	1	----	1972 324	
	CONNECTOR PACKAGE, Right, w/Air Outlet Tube, SY1	8	1	----	----	2279 917
24-28-59	SCREW, Recirculating Door Link, SD3	8	1	----	1885 835	1885 835
24-28-60	COVER, Rear Unit Evaporator Housing, Rear	8	1	----	----	1648 380
24-28-63	GASKET, Heater Core Cover, SD3	8	1	----	1879 861	1879 861
24-28-64	VACUUM TUBE REPAIR KIT		★	----	⊠2448 621	
	VACUUM TUBE REPAIR KIT		★	----	⊠2448 620	
	VACUUM TUBE REPAIR KIT		★	----	⊠2275 215	⊠2275 215
24-28-70	GRILLE, Rear Unit Inlet, except SY1	8	1	----	----	1885 901
	SY1	8	1	----	----	1887 501
24-28-72	CLIP, Grille, Front Unit Inlet, except SY1	8	4	----	----	1331 850
	Recirculating Door Link	8	1	----	----	666 790
	Retainer, Outlet Louver, except SY1	8	★	----	----	1972 979
24-28-73	DUCT, Outlet, Frt. Unit, Left, except SY1	8	1	----	----	1972 956
	DUCT, Outlet, Frt. Unit, Right, except SY1	8	1	----	----	1972 359
	DUCT, Connector, Right to Bezel, also to Distribution Duct, Frt. Unit, SY1	8	2	----	----	2219 019
	DUCT, Air Return, Rear Unit, except SY1, SD3	8	1	----	*1972 360	*1972 360
	DUCT, Air Return, Rear Unit, SY1	8	1	----	----	1648 430
	DUCT, Air Outlet, Rear Unit	8	2	----	----	*1648 407
	DUCT, Fresh Air Intake, except SD3	8	1	----	2277 342	
	DUCT PACKAGE, Air Outlet Right, includes CONNECTOR, Front Unit, SY1	8	1	----	----	⊠2279 917
	DUCT, Spot Cooler, Left		1	----	⊠2219 924	
	DUCT, Outlet, Right, SD3	8	1	----	⊠2219 010	⊠2219 010
24-28-75	BEZEL, Air Outlet, Frt. Unit, Right, except SY1	8	1	----	----	1972 960
	Left, except SY1	8	1	----	----	1972 961
	Air Outlet, includes Louver, Frt. Unit	8	1	----	2219 396	
	SD3, Outlet	8	1	----	2219 004	
24-28-76	RETAINER, Inlet Duct to Evaporator, Rear Unit, except SY1	8	2	----	----	1886 025
	SY1	8	2	----	----	1648 460
	Inlet Duct to Shelf, except SY1	8	2	----	----	2097 010

★ Indicates use as required.
 ⊠ Indicates parts not listed in any previous parts book.
 * Indicates change or addition.

Printed in U.S.A.
 Prices and specifications subject to change without notice.
 March 8, 1963 Supersedes May 1, 1962.

1962 PASSENGER CAR PARTS CATALOG

AIR CONDITIONING

CODE	PART NAME AND DESCRIPTION	C Y L.	PER CAR	VALIANT LANCER	PLYMOUTH DODGE	CHRYSLER IMPERIAL
24-28-0 EVAPORATOR - Cont'd						
24-28-78	LOUVER, Air Outlet, Frt. Unit w/BEZEL	8	1	----	2219 396	
	Air Outlet, Frt. Unit, w/FRAME, SD3, SC1, SC2, SC3	8	4	----	2219 057	*2219 057
	Right, SY1, w/HOUSING	8	1	----	----	2197 370
	Left, SY1, w/HOUSING	8	1	----	----	2197 371
	LOUVER, w/HOUSING, Rear Unit	8	2	----	----	2096 940
	Roof Unit, Sub.	8	4	----	----	1838 380
	GRILLE, Model G, includes FRAME	1		*1997 542	*1997 542	*1997 542
24-28-79	SCREEN, Inlet Grille, Rear Unit, SY1	8	1	----	----	1570 956
24-28-80	DEFLECTOR, Floor, Frt. Unit, Left, SD3	8	1	----	*1886 413	*1886 413
24-28-83	GASKET, Air Outlet Louver, except SY1	8	4	----	----	2277 050
24-28-84	ADAPTER, Air Outlet Louver, Roof Unit, Sub.	8	1	----	----	1753 579
24-28-90	DOOR, Fresh Air, except SD3		1	----	2162 418	
24-28-92	SEAL, Door Housing to Dash		1	----	2162 245	
24-28-93	CONNECTOR, Air Outlet, Right, SY1, w/TUBE	8	★	----	2219 798	2219 019
	Left, SY1, w/TUBE	8	1	----	2219 799	2279 917
	CONNECTOR, Outlet Duct, Rubber, SD3	8	1	----	2096 024	2096 024
24-28-98	VANE, Horizontal, Model G		4	1997 541	1997 541	1997 541
	VANE, Vertical, Model G		8	1998 591	1998 591	1998 591
	VANE, Horizontal Control, Model G		2	1997 545	1997 545	1997 545
	VANE, Vertical Control, Model G		4	1998 590	1998 590	1998 590
24-28-99	LINKAGE, Heater Control, on Evaporator	8	1	----	2277 124	
24-28-101	RETAINER, Fresh Air Door Shaft, except SD3		1	----	2162 360	
24-28-104	BALL STUD, Recirculating Door Link		1	----	1858 936	
24-28-106	RETAINER, Recirculating Door Ball Joint		1	----	1945 197	
24-28-108	SPRING, Fresh Air Door over Center		1	----	2277 262	
24-28-113	HOUSING, Fresh Air Door, except SD3		1	----	*2162 239	
24-28-175	HOUSING, Blower, Rear Unit	8	1	----	----	1648 394
	Model G		2	1991 576	1991 576	1991 576
	Sub. CCW	8	1	----	----	*1887 300
	Sub. CW	8	1	----	----	*1887 299
24-28-176	SEAL, Distribution Duct Inlet to Dash, SD3	8	1	----	1887 757	1887 757
24-28-186	ROTOR, Axial, Blower		1	----	2219 103	
24-28-195	MOTOR, Axial, w/Mtg. PLATE		1	----	2277 418	
	Frt. Unit, SD3	8	1	----	*1879 579	*1879 579
	Rear Unit	8	2	----	----	1887 401
	Roof Unit	8	2	----	----	1886 266
	Model G		1	1985 536	1985 536	1985 536
	WASHER, Blower Motor to Blower, Roof Unit	8	16	----	----	6006 065
	WASHER, Blower Motor Mtg.	8	12	----	----	6006 065
24-28-199	RING, w/BRACKET, Axial Blower		1	----	2277 585	
24-28-200	SPACER, Distribution Duct to Dash	6	1	----	1704 198	
	Motor Mtg. Bracket to Plate, Rear Unit	8	1	----	1605 271	1605 271

★ Indicates use as required.

□ Indicates parts not listed in any previous parts book.

March 8, 1963 Supersedes May 1, 1962.

Printed in U.S.A.

Prices and specifications subject to change without notice.

* Indicates change or addition.

CODE	PART NAME AND DESCRIPTION	CYL	PER CAR	VALIANT LANCER	PLYMOUTH DODGE	CHRYSLER IMPERIAL
24-28-O EVAPORATOR - Cont'd						
24-28-204	SPACER, Fan Pulley, Model G		1	2003 059	2003 059	2003 059
24-28-205	CLIP, Axial Blower Motor Balancing, 1/4" width, 1 1/8" lgh.		★	----	*2277 247	
	9/16" width, 1 1/8" lgh.		★	----	*2277 248	
	13/16" width, 1 1/8" lgh.		★	----	*2277 249	
	CLIP, Balancing Wire Retainer		1	----	2277 263	
	13/16" width, 1 1/8" lgh.		★	----	E2277 672	
	35/64" width, 1 1/8" lgh.		★	----	E2277 671	
	17/64" width, 1 1/8" lgh.		★	----	E2277 670	
	1/4" width, 3/4" lgh.		★	----	E2277 884	
	1/4" width, 1" lgh.		★	----	E2277 885	
	1/4" width, 1 1/2" lgh.		★	----	E2277 186	
	1/4" width, 2" lgh.		★	----	E2277 887	
	1/4" width, 2 1/2" lgh.		★	----	E2277 888	
24-28-210	WHEEL, Blower Motor, Frt. Unit, SD3	8	★	----	*1880 442	*1880 442
	Rear Unit, except Sub.	8	2	----	----	1235 644
	Right, Model G		1	1985 539	1985 539	1985 539
	Left, Model G		1	1985 537	1985 537	1985 537
	Sub. CCW	8	1	----	----	*1886 263
	Sub. CW	8	1	----	----	*1886 265
24-28-220	COIL, Evaporator, Frt. Unit, except SD3		1	----	2219 837	2096 253
	SD3	8	1	----	2096 253	
	Rear Unit	8	1	----	----	1880 642
	Roof Unit, Sub.	8	1	----	----	1886 249
	Model G	6	1	1991 581		
	Model G		1	----	2003 074	1991 581
	STUD, Coil Drain 3/8" lgh., 3/8" head		2	----	*6024 097	
	STUD, Coil Drain 3/8" lgh., 1/2" head		2	----	*6024 098	
24-28-230	RING, Defroster Damper		★	----	*1539 430	
24-28-232	THERMO, w/Mtg. PLATE, except SD3		1	----	2219 639	
24-28-235	NUT, Evaporator Coil Grommet, SD3	8	★	----	1605 267	1605 267
24-28-241	SWITCH, Thermo, Model G		1	1997 564	1997 564	1997 564
24-28-248	KNOB, Thermo Switch, Model G		1	1997 553	1997 553	1997 553
24-28-300	VALVE, Expansion, Front and Rear Unit, except SD3	8	1	----	2275 584	1879 580
	SD3	8	1	----	1879 580	
	Roof Unit, Sub.	8	1	----	----	1887 364
	w/Model G	6	1	1999 149		
	w/Model G		1	----	1991 619	1991 619
24-28-305	CLIP, Tube Mtg. to Center Bracket, SY1	8	1	----	----	2277 668
24-28-318	TEE, Control Tube, Plastic, SD3	8	1	----	*1886 109	*1886 109
	Liquid Hose	8	1	----	----	1885 692
24-28-322	INDICATOR PACKAGE		1	----	2275 597	1880 657
	Model G		1	1744 768	1744 768	1744 768
	SD3, w/361 cu. in. Eng.	8	1	----	1880 657	
24-28-326	SEAL, Air Conditioning Tube, Rubber, 1/4" O.D.		★	----	2277 190	2277 190
	3/8" O.D.		★	----	2219 383	2219 383
	1/2" O.D.		★	----	2219 384	2219 384
	5/8" O.D.		★	----	2219 385	2219 385

★ Indicates use as required.
 E Indicates parts not listed in any previous parts book.
 * Indicates change or addition.

1962 PASSENGER CAR PARTS CATALOG

AIR CONDITIONING

CODE	PART NAME AND DESCRIPTION	C Y L	P E R C A R	VALIANT LANCER	PLYMOUTH DODGE	CHRYSLER IMPERIAL
24-28-O EVAPORATOR - Cont'd						
24-28-357	NUT, Floor Air Damper Control Mounting, SD3 . . .	8	1	----	1339 711	1339 711
	NUT, Blower Switch Mtg.	8	1	----	1339 711	
	NUT, Floor Damper Rotary Control, SD3	8	1	----	1972 548	
24-28-359	SHAFT, Deflector, w/LEVER, SD3	8	1	----	1972 817	
24-28-361	CLIP, Temperature Control Cable		1	----	6015 143	6015 143
24-28-363	KNOB, Floor Damper Control	8	1	----	----	1887 935
	SD3	8	1	----	2257 478	
24-28-364	DUCT, Distribution, SD3	8	1	----	1972 594	1972 594
24-28-366	CONTROL, Floor Air Damper, except SY1	8	1	----	----	2096 112
	SY1	8	1	----	----	2198 024
	SD3	8	1	----	2096 111	
24-28-368	WASHER, Defroster Shaft, SD3	8	1	----	1971 463	1971 463
24-28-378	NUT, Defroster Shaft, SD3	8	1	----	1829 825	
24-28-379	DOOR PACKAGE, Defroster, SD3	8	1	----	2084 295	
24-28-382	BEZEL, Floor Air Damper Control SD3	8	1	----	*2197 498	
24-28-384	COVER, Deflector Lever, SD3	8	1	----	2097 152	2097 152
24-28-387	SPOT COOLER, Right		1	----	2277 412	
	Left		1	----	2219 736	
	SD3, SC1, SC2, SC3	8	1	----	1972 372	1972 372
	w/SPACER, SY1	8	1	----	----	2197 885
24-28-392	CLIP, Deflector Actuator Shaft, SD3	8	1	----	2197 678	2197 678
24-28-393	BUMPER, Spot Cooler Door	8	1	----	2080 201	
24-28-396	CLAMP, Spot Cooler Tube Mtg., Right		2	----	2277 426	
24-28-397	BRACKET, Spot Cooler Tube Mtg., Out Board . . .		1	----	2277 428	
	In Board		1	----	2277 427	
24-29-O ACTUATOR						
24-29-1	ACTUATOR, Defroster, except SD3	8	1	----	2219 916	2277 051
	Defroster, SD3	8	1	----	2277 051	
	Deflector, SD3	8	1	----	2277 053	2277 053
	Recirculating Door, SD3	8	1	----	2277 052	2277 052
	By-Pass Door, SD3	8	1	----	2277 054	2277 054
	Spot Cooler		1	----	2219 915	
24-29-14	RETAINER, Vacuum Actuator Shaft		★	----	2197 678	2197 678
	RETAINER, Deflector Actuator Shaft, SD3	8	★	----	2076 405	2076 405

NOTES

★ Indicates use as required.
 □ Indicates parts not listed in any previous parts book.
 March 8, 1963 Supersedes May 1, 1962.

Printed in U.S.A.
 Prices and specifications subject to change without notice.
 * Indicates change or addition.