

GROUP 9 - ENGINE

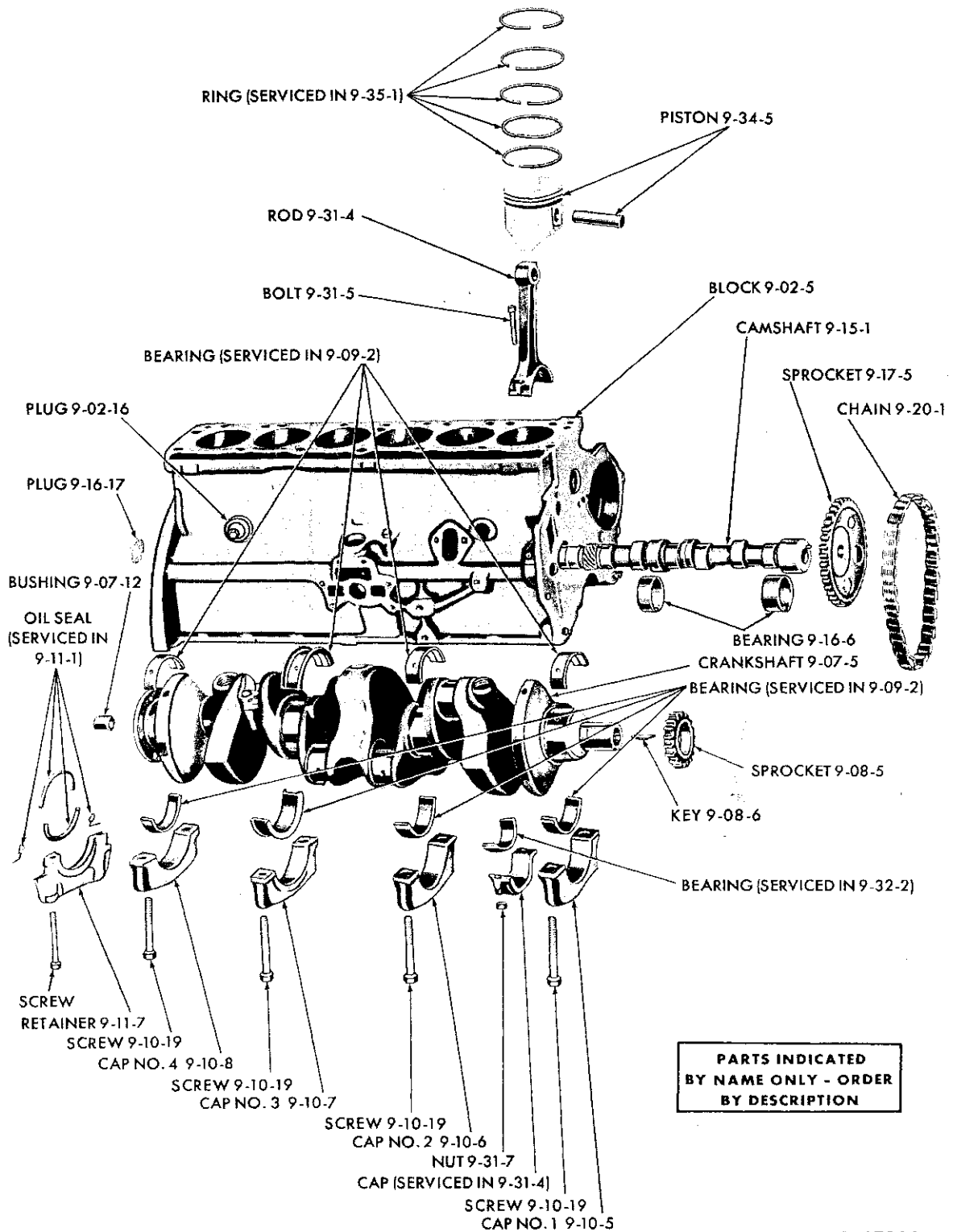

**PARTS INDICATED
BY NAME ONLY - ORDER
BY DESCRIPTION**

19x8786A

SHORT ENGINE - 6 CYLINDER

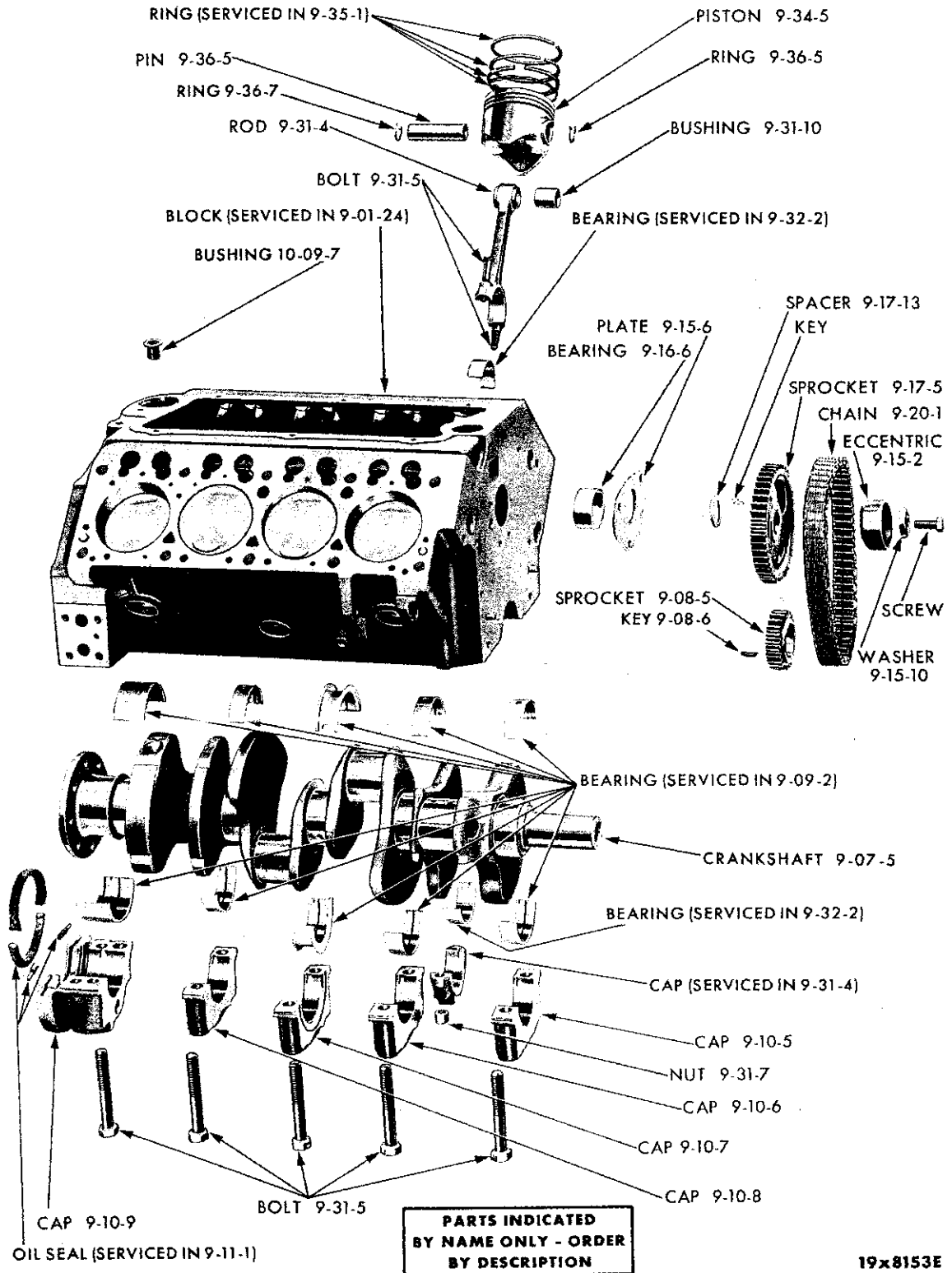

19x8153E

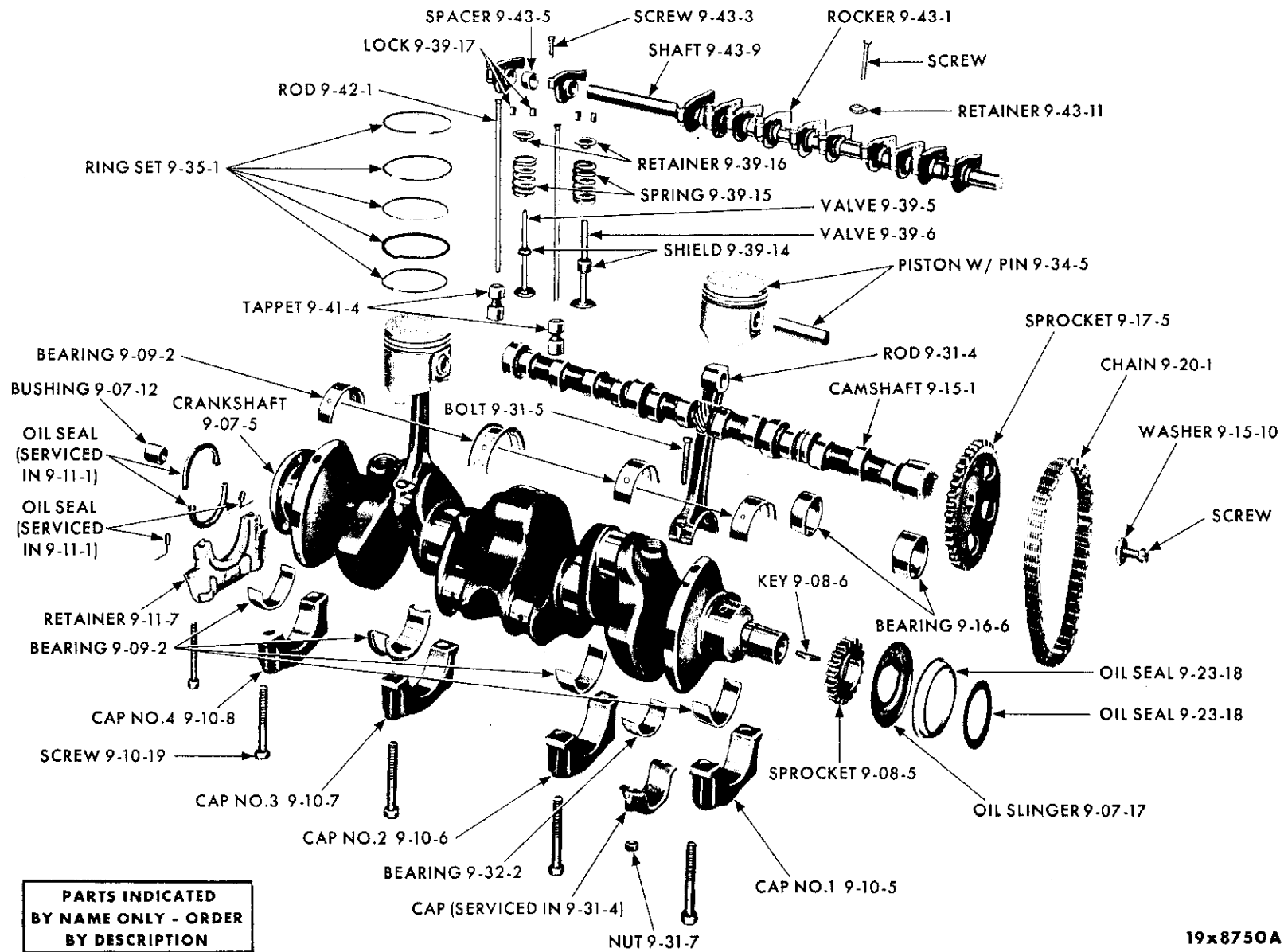

**PARTS INDICATED
BY NAME ONLY - ORDER
BY DESCRIPTION**

19x8750A

ENGINE INTERNAL PARTS - 6 CYLINDER

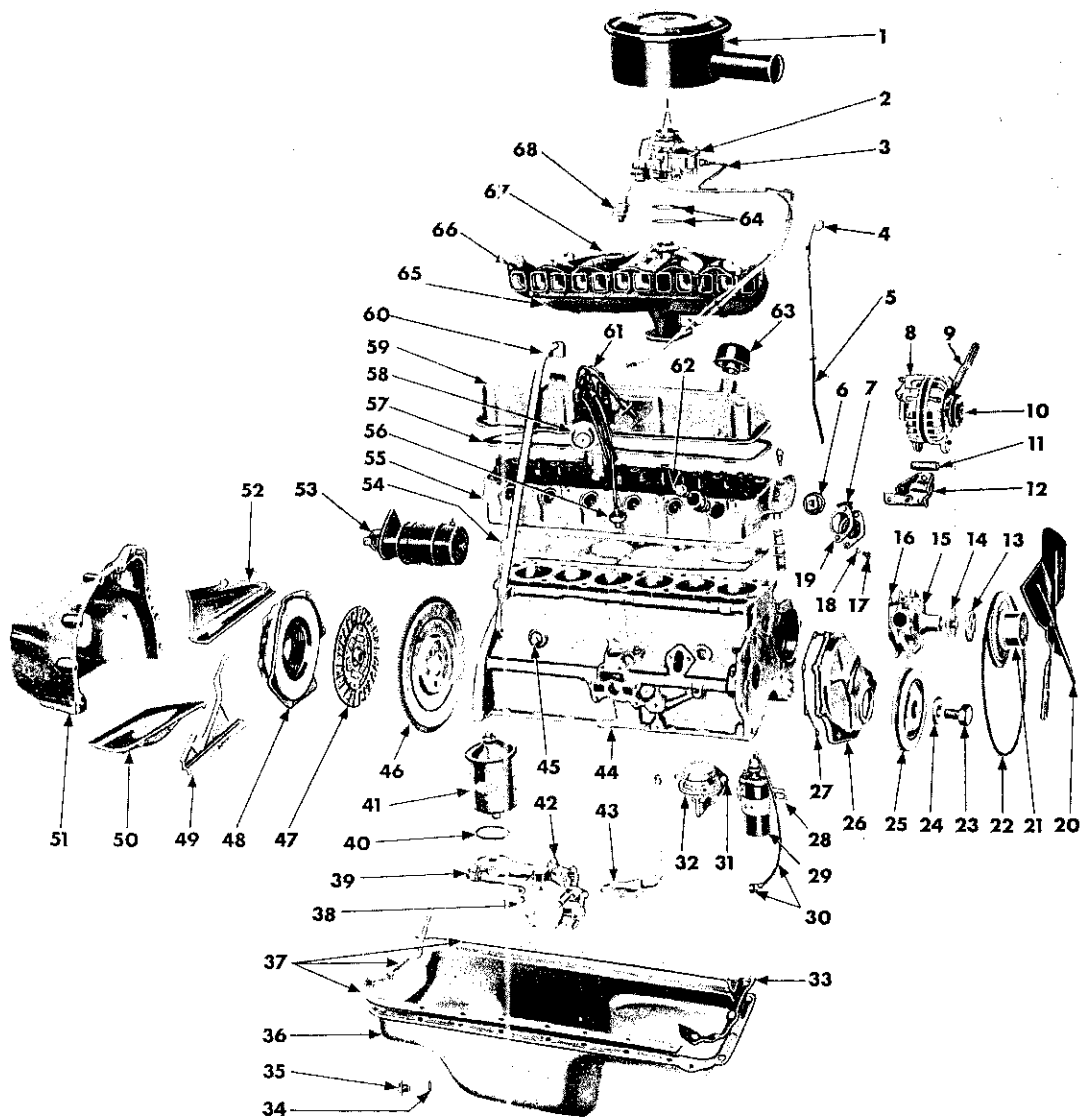

19L8794A

ENGINE EXTERNAL PARTS - 6 CYLINDER

ENGINE EXTERNAL PARTS - 6 CYLINDER

Ref. No.	Name	Part Type Code	Ref. No.	Name	Part Type Code
1	Air Cleaner	14-29-2	35	Plug	10-24-37
2	Carburetor	14-30-1	36	Pan	10-24-4
3	Tube	14-89-2	37	Gasket (Serviced in 10-24-1)	
4	Indicator	10-03-4	38	Pump	10-07-6
5	Tube	10-03-7	39	Cap	10-22-40
6	Thermostat	7-41-4	40	Gasket (Serviced in 10-26-6)	
7	Elbow	9-05-5	41	Filter	10-26-6
8	Alternator	8-28-3	42	Gasket	10-07-11
9	Strap	8-28-15	43	Strainer, w/Pipe	10-23-7
10	Pulley	8-28-297	44	Block	9-02-5
11	Spacer	Not Serviced	45	Plug	
12	Bracket	8-28-36	46	Flywheel	9-45-1
13	Spacer	7-02-16	47	Disc	6-13-1
14	Hub	7-05-1	48	Cover, w/Plate	6-14-1
15	Pump Package	7-42-1	49	Seal	6-10-10
16	Gasket	7-44-4	50	Pan	6-10-2
17	Screw		51	Housing	6-09-1
18	Washer		52	Strut	6-09-11
19	Gasket	9-05-6	53	Starter	8-52-4
20	Fan	7-02-1	54	Gasket	9-03-5
21	Pulley	7-06-14	55	Head	9-03-4
22	Belt	7-03-1	56	Cover	8-36-117
23	Screw	9-07-8	57	Gasket	9-03-29
24	Washer	9-07-22	58	Distributor	8-27-1
25	Damper	9-13-5	59	Cover	9-03-28
26	Cover	9-23-5	60	Pipe	10-02-15
27	Gasket	9-23-17	61	Cable Set	8-36-1
28	Bracket	8-35-41	62	Spark Plug	8-36-114
29	Coil	8-35-4	63	Air Cleaner	10-01-21
30	Cable	8-36-49	64	Gasket	14-30-2
31	Gasket	14-74-1	65	Manifold	9-48-6
32	Pump Package	14-73-1	66	Gasket (Serviced in 9-50-1)	
33	Gasket	10-24-1	67	Manifold	9-48-7
34	Gasket	10-24-38	68	Choke	14-39-45

PARTS INDICATED BY NAME ONLY - ORDER BY DESCRIPTION

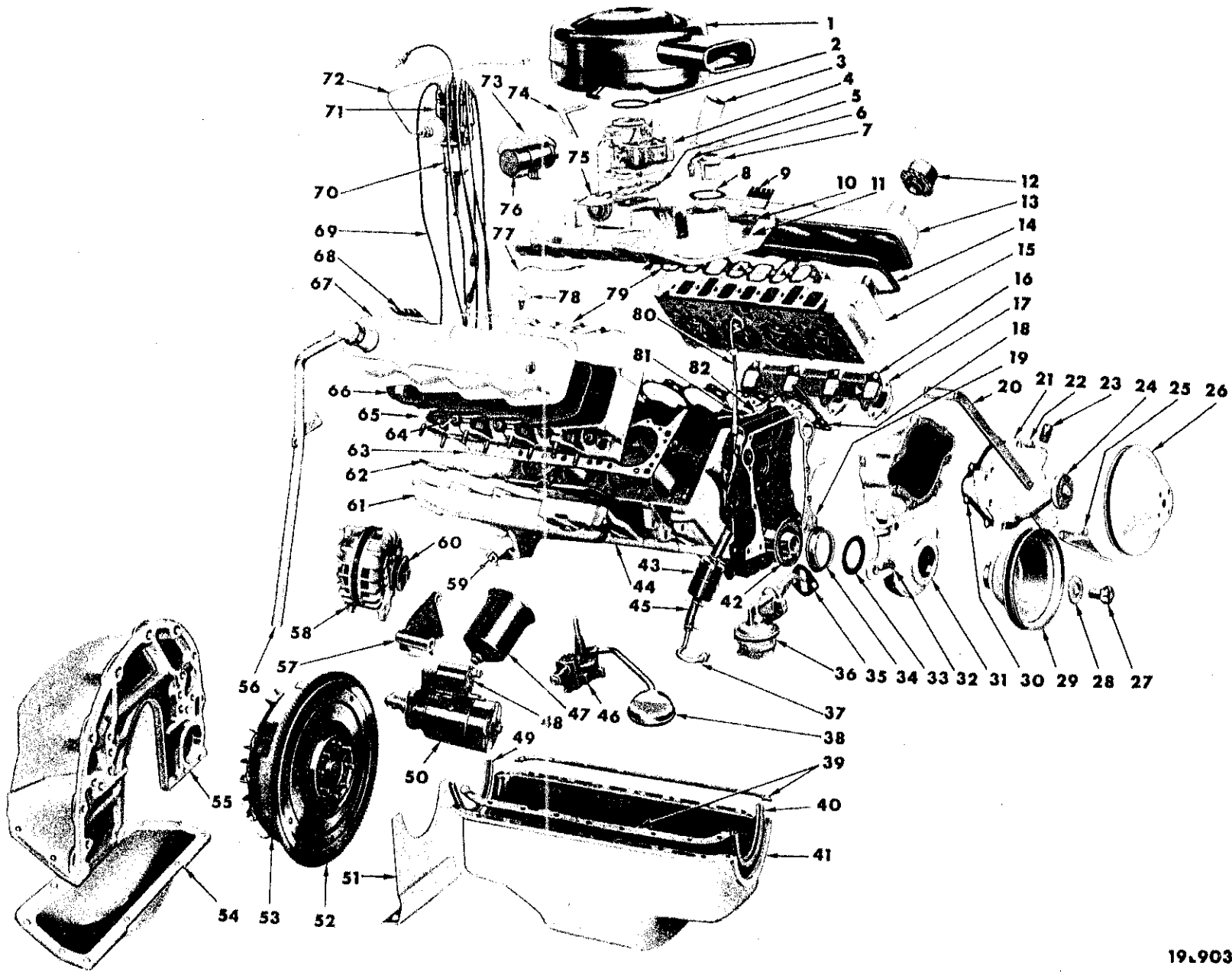

ENGINE EXTERNAL PARTS - V8 CYLINDER ("A" ENGINE)

19-9033

ENGINE EXTERNAL PARTS - V8 CYLINDER ("A" ENGINE)

Ref. No.	Name	Part Type Code	Ref. No.	Name	Part Type Code
1	Air Cleaner	14-29-2	42	Oil Slinger	9-07-17
2	Gasket	14-29-5	43	Filter	14-67-1
3	Elbow	9-05-5	44	Block (Serviced in 9-01-24)	
4	Carburetor	14-30-1	45	Hose	14-67-2
5	Gasket	14-30-2	46	Pump	10-07-6
6	Sending Unit	8-37-155	47	Shell	10-26-14
7	Thermostat	7-41-4	48	Solenoid	8-52-345
8	Gasket	9-05-6	49	Gasket (Serviced in 10-24-1)	
9	Bracket	8-36-4	50	Starting Motor	8-52-4
10	Nipple	7-48-22	51	Cover	9-46-93
11	Manifold	9-48-6	52	Gear	9-45-2
12	Air Cleaner	10-01-21	53	Torque Converter	9-46-4
13	Cover	9-03-28	54	Pan	9-46-137
14	Gasket	9-03-29	55	Housing	9-46-90
15	Head	9-03-4	56	Pipe	10-02-15
16	Gasket	9-50-5	57	Bracket	8-28-36
17	Manifold	9-48-6	58	Alternator	8-28-3
18	Gasket	9-03-5	59	Shield	9-58-12
19	Gasket	9-23-17	60	Pulley	8-28-297
20	Strap	8-28-15	61	Manifold	9-48-6
21	Pump Package	7-42-1	62	Gasket	9-50-5
22	Plug		63	Gasket	9-03-5
23	Nipple	7-48-22	64	Plug	8-36-114
24	Hub	7-05-1	65	Head	9-03-4
25	Indicator	9-23-40	66	Gasket	9-03-29
26	Pulley	7-06-14	67	Cover	9-03-28
27	Screw	9-07-8	68	Bracket	8-36-4
28	Washer	9-07-22	69	Cable	8-36-1
29	Pulley	7-06-1	70	Retainer	8-27-4
30	Gasket	7-44-3	71	Distributor	8-27-1
31	Cover	9-23-5	72	Tube	8-27-320
32	Screw	9-23-10	73	Resistor	8-35-22
33	Gasket (Serviced in 9-23-18)		74	Bracket	14-06-10
34	Oil Seal	9-23-18	75	Choke, w/Rod	14-64-2
35	Gasket	14-74-1	76	Coil	8-35-4
36	Pump	14-73-2	77	Gasket (Serviced in 9-50-1)	
37	Tube	14-89-2	78	Switch	8-53-327
38	Strainer	10-23-7	79	Gasket (Serviced in 9-50-1)	
39	Gasket (Serviced in 10-24-1)		80	Indicator	10-03-4
40	Gasket (Serviced in 10-24-1)		81	Tube	10-03-7
41	Pan	10-24-4	82	Gasket (Serviced in 9-50-1)	

PARTS INDICATED BY NAME ONLY - ORDER BY DESCRIPTION

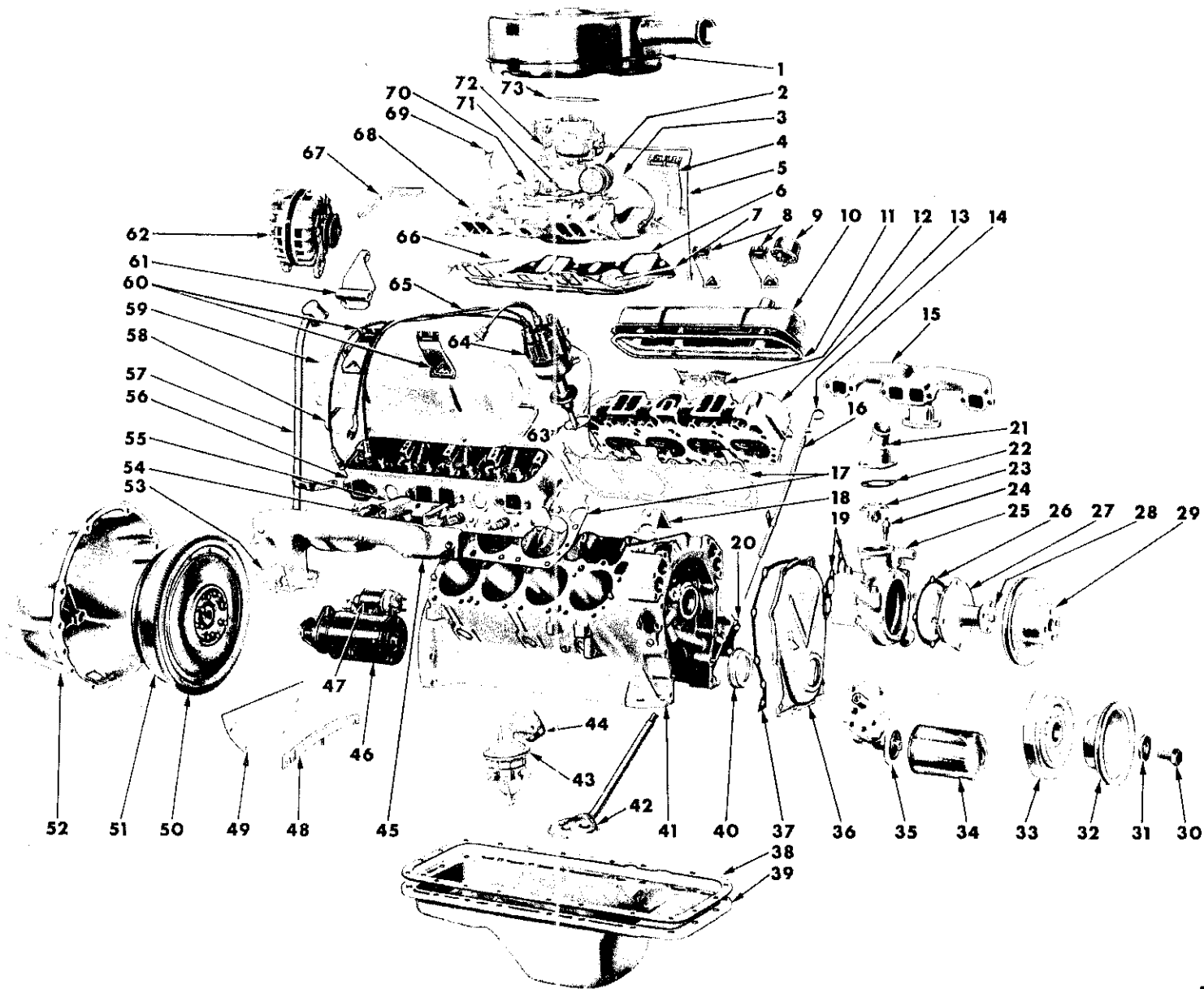

19L9032

ENGINE EXTERNAL PARTS - V8 CYLINDER ("B" ENGINE)

ENGINE EXTERNAL PARTS - V8 CYLINDER ("B" ENGINE)

Ref. No.	Name	Part Type Code	Ref. No.	Name	Part Type Code
1	Air Cleaner	14-29-2	38	Gasket	10-24-8
2	Coil	8-35-4	39	Pan	10-24-4
3	Tube	8-27-320	40	Oil Seal	9-23-18
4	Bracket	8-36-4	41	Block (Serviced in short engine 9-01-24)	
5	Tube	14-85-1	42	Strainer	10-23-7
6	Gasket	9-50-6	43	Pump Package	14-73-1
7	Reinforcement	9-48-27	44	Gasket	14-74-1
8	Bracket	8-36-4	45	Manifold	9-48-6
9	Air Cleaner	10-01-21	46	Starter	8-52-4
10	Cover	9-03-28	47	Solenoid	8-52-345
11	Gasket	9-03-29	48	Support	11-08-4
12	Shield	8-36-124	49	Cover	9-46-93
13	Head	9-03-4	50	Gear	9-45-2
14	Indicator	10-03-4	51	Torque Converter	9-46-4
15	Manifold	9-48-6	52	Housing	9-46-90
16	Tube	10-03-7	53	Shield	9-58-12
17	Gasket	9-03-5	54	Spark Plug	8-36-114
18	Clamp	8-27-26	55	Shield	8-36-124
19	Gasket	7-44-4	56	Head	9-03-4
20	Gasket	10-07-11	57	Pipe	10-02-15
21	Elbow	9-05-5	58	Gasket	9-03-29
22	Gasket	9-05-6	59	Cover	9-03-28
23	Thermostat	7-41-4	60	Bracket	8-36-4
24	Fitting		61	Bracket	8-28-36
25	Housing	7-43-1	62	Alternator	8-28-3
26	Gasket	7-44-3	63	Retainer	8-27-4
27	Pump Package	7-42-1	64	Distributor	8-27-1
28	Hub	7-05-1	65	Cable Set	8-36-1
29	Pulley	7-06-14	66	Reinforcement	9-48-27
30	Screw	9-07-8	67	Strap	8-28-15
31	Washer	9-07-22	68	Manifold	9-48-7
32	Pulley	7-06-1	69	Bracket	14-29-12
33	Damper	9-13-5	70	Choke	14-39-45
34	Oil Filter	10-26-6	71	Gasket	14-30-2
35	Pump	10-07-6	72	Carburetor	14-30-1
36	Cover	9-23-5	73	Gasket	14-29-5
37	Gasket	9-23-17			

PARTS INDICATED BY NAME ONLY - ORDER BY DESCRIPTION

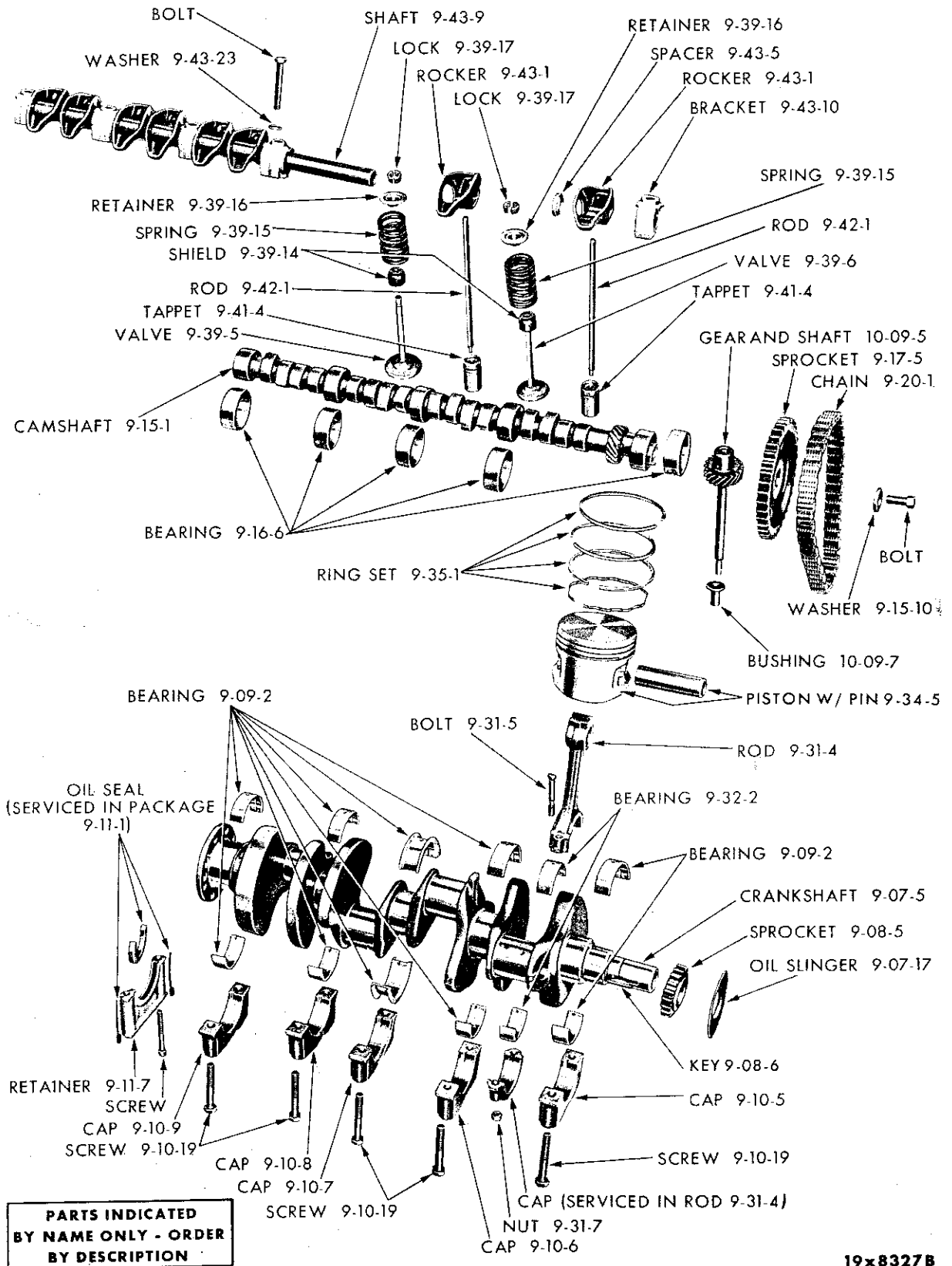

ENGINE INTERNAL PARTS - V8 CYLINDER ("B" ENGINE)

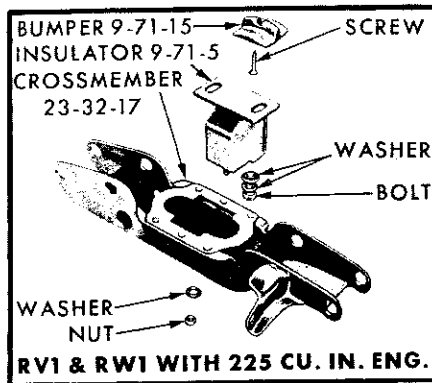

**PARTS INDICATED
BY NAME ONLY - ORDER
BY DESCRIPTION**

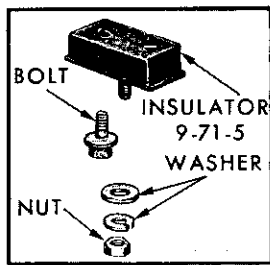
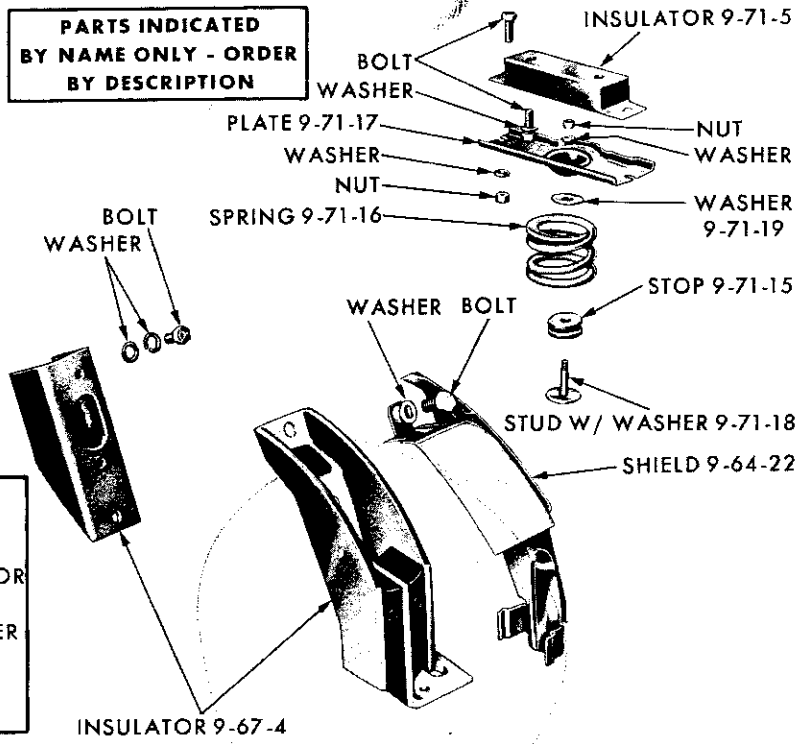

19x9148

ENGINE MOUNTINGS - 6 CYLINDER

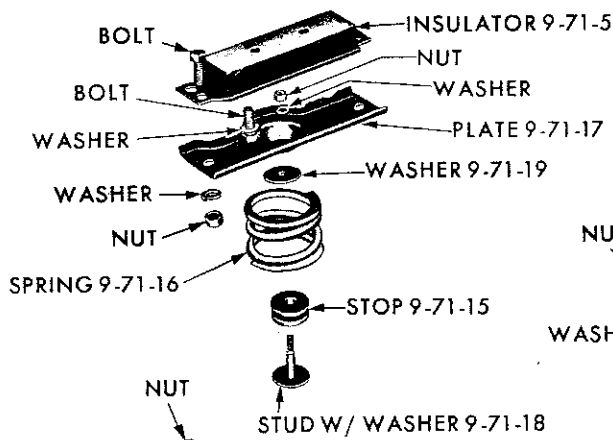

**PARTS INDICATED
BY NAME ONLY - ORDER
BY DESCRIPTION**

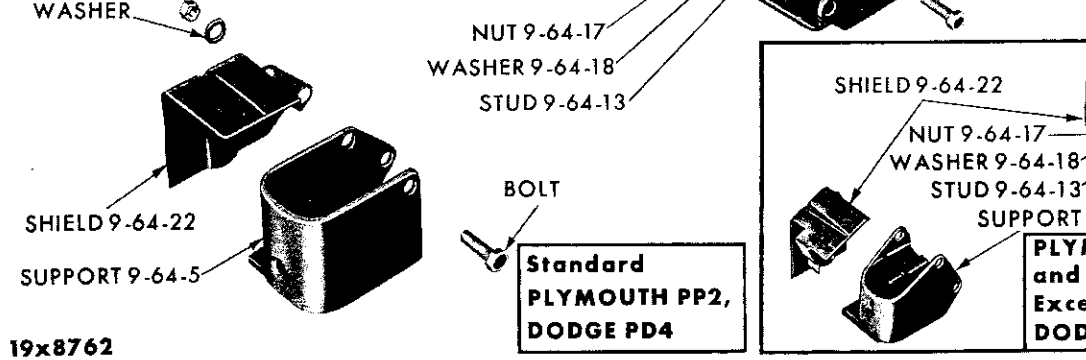

**Standard
PLYMOUTH PP2,
DODGE PD4**

**PLYMOUTH PP2
and DODGE PD4
Except Standard,
DODGE PD1-2**

19x8762

ENGINE MOUNTINGS - V8 CYLINDER

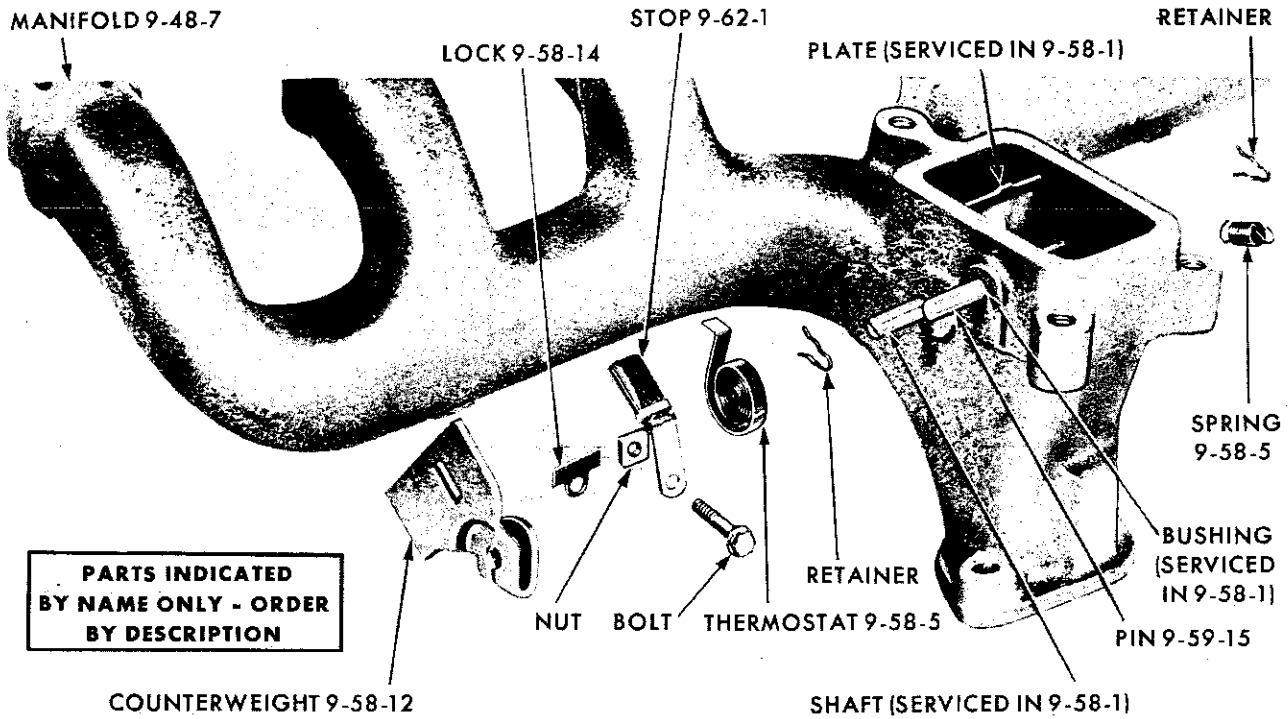

**PARTS INDICATED
BY NAME ONLY - ORDER
BY DESCRIPTION**

19x8775

MANIFOLD HEAT CONTROLS - 6 CYLINDER

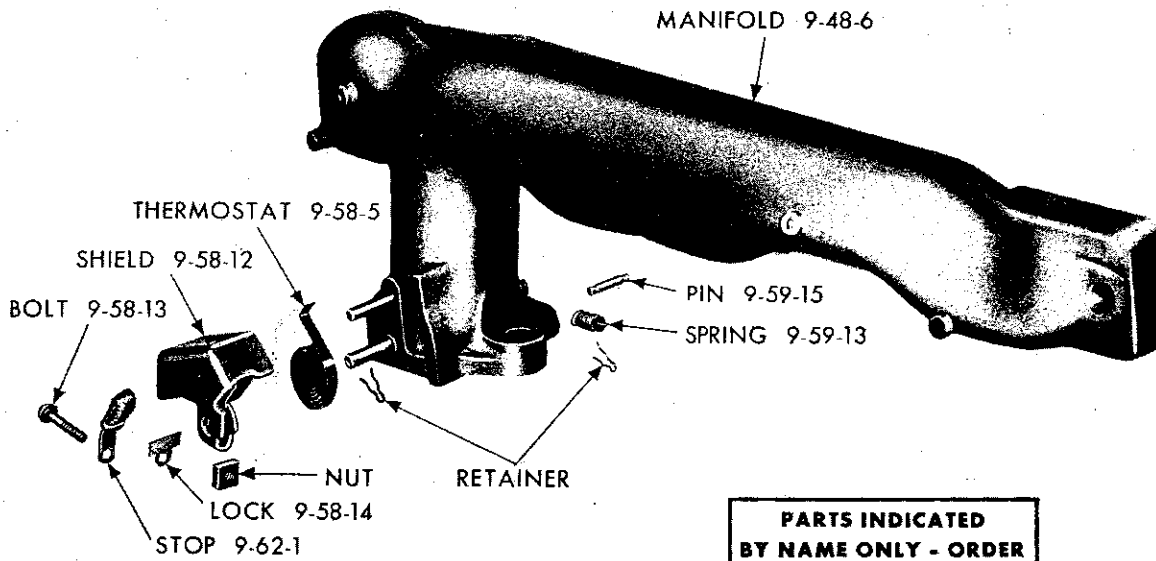

**PARTS INDICATED
BY NAME ONLY - ORDER
BY DESCRIPTION**

19x8318A

MANIFOLD HEAT CONTROLS - V8 CYLINDER

9-01-0 ENGINE ASSEMBLY

NOTE: The following symbols are used in connection with engine numbers:

Engine numbers without symbols indicate "Standard Cylinders and Crankshaft Bearings."

The Letter "A" immediately following the engine number indicated Bore .020" (.508 MM.) Larger than Standard.

The Letter "B" immediately following the engine number indicated Main and Connecting Rod Bearings .010" (.245 MM.) Smaller than Standard.

The Letters "AB" immediately following the engine number indicate Cylinder Bore .020" (.508 MM.)

Larger than Standard and the Main and Connecting Rod Bearings .010" (.254 MM.) Smaller than Standard.

The Letters in the circular pads at either end of the engine number are for the use of factory inspectors only and should not be connected with the engine number. Always mention Serial Numbers when ordering major assemblies.

CODE	PART NAME AND DESCRIPTION	C Y L.	PER CAR	VALIANT	PLYMOUTH	DESOTO	CHRYSLER	IMPERIAL
9-01-5	GASKET SET	6	1	2196 045	2196 045			
	w/225 cu.in. Aluminum Engine	6	1	2240 628	2240 628			
		8	1	----	2196 087			
	RP2 w/High Performance, RP2 w/Police Cars, RC1, RC2 . .	8	1	----	1879 701	1879 701	1879 701	
	RC2, RC3, RC4	8	1	----	----	----	1879 702(1)	1879 702
<p>NOTE: Short Engine Assemblies consists of: The Cylinder Block with Pistons and Rings, Crankshaft and Bearings, Connecting Rods and Bearings, Camshaft and Bearings, Camshaft Thrust Plate, Camshaft and Crankshaft Sprockets and Timing Chain. On the 8 Cylinder Short Engine Assemblies some of the above parts have been left off to obtain a greater interchangeability.</p>								
9-01-24	SHORT ENGINE	6	1	2206 136				
	Export L. H. D.	6	1	2206 138				
	8.2 to 1 Compression Ratio							
	Export R. H. D.	6	1	2206 140				
	w/225 cu. in. Cast Iron Engine	6	1	2206 132	2206 132			
	Export	6	1	----	2206 134			
	w/225 cu. in. Aluminum Engine	6	1	2264 401	2264 401			
		8	1	----	1859 497			
	Export	8	1	----	1859 499			
	RP2 w/High Performance, RC1 361 cu.in. Engine	8	1	----	2205 941	2205 941	2205 941	
	RC2	8	1	----	----	----	1859 488(1)	
	RP2 Police Cars w/one four barrel carburetor, RP2 Police Cars w/Ram Manifold, RC2 w/383 cu. in. Engine	8	1	----	2128 668	----	2128 668	----
RC3, RC4	8	1	----	----	----	1859 492	1859 492	
RC1 Export	8	1	----	----	2205 942	2205 942		
9-02-0 CYLINDER BLOCK								
9-02-5	BLOCK, w/PISTONS and RINGS	6	1	2202 866				
	L. C. Export	6	1	2203 097				
	w/225 cu. in. Cast Iron Engine	6	1	2206 495	2206 495			
	L. C. Export	6	1	----	*2206 498			
	w/225 cu. in. Aluminum Engine	6	1	2206 119	2206 119			
9-02-7	DOWEL, Cylinder Block to Clutch Housing or Torque Converter Housing		2	1122 532	1122 532	1122 532	1122 532	1122 532

NOTE 1: Used only on RC2 with D-1 code Disc and stamped RR-38 on Ser. No. Pad.

★ Indicates use as required.

Numerals in parentheses () refer to notes.

Printed in U.S.A.

⊠ Indicates parts not listed in any previous parts book.

Prices and specifications subject to change without notice.

* Indicates change or addition.

1961 PASSENGER CAR PARTS CATALOG

ENGINE

CODE	PART NAME AND DESCRIPTION	C Y L.	PER CAR	VALIANT	PLYMOUTH	DESOTO	CHRYSLER	IMPERIAL
9-02-0 CYLINDER BLOCK - Cont'd								
9-02-9	DOWEL, Cylinder Block to Bearing Cap	8	1	----	1408 853			
	w/225 cu. in. Aluminum Engine	6	1	2129 004	2129 004			
9-02-12	PLUG, Cylinder Block Oil Gallery, Front w/225 cu. in. Aluminum Engine	6	1	2121 718	2121 718			
	Rear, w/225 cu. in. Aluminum Engine	6	1	2129 351	2129 351			
9-02-13	SEAL, Cylinder Block Oil Gallery Rear Plug, w/225 cu. in. Aluminum Engine	6	1	2128 962	2128 962			
9-02-14	ORIFICE, Oil Line	8		----	1821 557			
9-02-16	PLUG, Core Hole	6	1	2121 197	2121 197			
		6	3	2121 198	2121 198			
		8	6	1821 721	1821 721	1821 721	1821 721	1821 721
9-03-0 CYLINDER HEAD								
9-03-4	HEAD	6	1	2205 848	2205 848			
	w/225 cu. in. Aluminum Engine	6	1	2206 056	2206 056			
	UP TO Eng. No. 200505	8	2	----	*1730 862			
	AFTER Eng. No. 200505	8	2	----	2268 340			
	RP2 w/High Performance, RP2 w/Police Cars	8	2	----	2128 589	2128 589	2128 589	2128 589
9-03-5	RC2	8	2	----	----	----	2128 553(1)	
	GASKET	6	1	1947 578	1947 578			
	w/225 cu. in. Aluminum Engine	6	1	2128 279	2128 279			
	UP TO Eng. No. 205312	8	2	----	*2129 655			
	AFTER Eng. No. 205312	8	2	----	2268 376			
	RP2 w/High Performance, RP2 w/Police Cars	8	2	----	1851 579	1851 579	1851 579	1851 579
9-03-10	SCREW	6	14	1947 687	1947 687			
	w/225 cu. in. Aluminum Engine	6	14	1947 686	1947 686			
	Short	8	10	----	1618 695			
	Long	8	10	----	1618 696			
	Short, RP2 w/High Performance, RP2 w/Police Cars	8	24	----	1739 605	1739 605	1739 605	1739 605
	Long, RP2 w/High Performance, RP2 w/Police Cars	8	10	----	1739 606	1739 606	1739 606	1739 606
9-03-18	PLUG, Core Hole, RP2 w/High Performance, RP2 w/Police Cars	8	4	----	1551 067	1551 067	1551 067	1551 067
9-03-28	COVER	6	1	2129 617	2129 617			
	Right	8	1	----	2202 812			
	Left	8	1	----	2128 405			
	RP2 w/High Performance, RP2 w/Police Cars, Right	8	1	----	2205 836	2205 836	2205 836	2205 836
	RP2 w/High Performance, RP2 w/Police Cars, Left	8	1	----	1851 924	1851 924	1851 924	1851 924
9-03-29	GASKET, Cover	6	1	2121 244	2121 244			
		8	2	----	2128 407			
	RP2 w/High Performance, RP2 w/Police Cars	8	2	----	1821 440	1821 440	1821 440	1821 440
9-03-34	SEAL, Cover Screw	8	6	----	1618 914			
9-05-0 CYLINDER HEAD WATER OUTLET ELBOW								
9-05-5	ELBOW	6	1	2121 524	2121 524			
	w/o Air Conditioning	8	1	----	1855 393	1855 393	1855 393	1855 393
	w/Air Conditioning, Model F	8	1	----	1859 542	1859 542	1859 542	1859 542
	w/Air Conditioning, RP2 w/High Performance, RP2 w/Police Cars w/one four Barrel Carburetor	8	1	----	1855 605	1855 605	1855 605	1855 605

NOTE 1: Used only on RC2 with D-1 code Disc and stamped RR-38 on Ser. No. Pad.

★ Indicates use as required.

Numerals in parentheses () refer to notes.

Printed in U.S.A.

⊠ Indicates parts not listed in any previous parts book.

Prices and specifications subject to change without notice.

March 1, 1962 Supersedes May 31, 1961.

* Indicates change or addition.

CODE	PART NAME AND DESCRIPTION	CYL.	PER CAR	VALIANT	PLYMOUTH	DESOTO	CHRYSLER	IMPERIAL
9-05-0 CYLINDER HEAD WATER OUTLET ELBOW - Cont'd								
9-05-6	GASKET, Cylinder Water Outlet Elbow	6	1	1947 671	1947 671			
		8	1	-----	50 082	50 082	50 082	50 082
9-07-0 CRANKSHAFT								
9-07-5	CRANKSHAFT, UP TO Eng. No. R17-5-26	6	1	*2202 487				
	AFTER Eng. No. R17-5-26	6	1	*2264 173				
	w/225 cu. in. Engine	6	1	2202 488	2202 488			
		8	1	-----	1859 752			
	RP2 w/High Performance, RP2 w/Police Cars, RC1, RC2	8	1	-----	1851 869	1851 869	1851 869	
	RC2, RC3, RC4	8	1	-----			1851 527(1)	1851 527
9-07-8	SCREW	6	1	-----	2128 569			
	w/Std. Trans.	8	1	-----	1821 414			
	w/Automatic Trans.	8	1	-----	1731 525			
	w/Air Conditioning		1	1821 177	1821 177			
	RP2 w/High Performance, RP2 w/Police Cars	8	1	-----	1731 525	1731 525	1731 525	1731 525
9-07-12	BUSHING, Crankshaft Transmission Drive Pinion Pilot RC1		1	53 298	53 298	53 298	53 298	
9-07-17	OIL SLINGER		1	1618 686	1618 686	1618 686	1618 686	1618 686
9-07-22	WASHER, Screw	8	1	-----	1855 561	1855 561	1855 561	1855 561
9-08-0 CRANKSHAFT SPROCKET								
9-08-5	SPROCKET	6	1	1737 621	1737 621			
		8	1	-----	1632 280			
	RP2 w/High Performance, RP2 w/Police Cars	8	1	-----	1737 621	1737 621	1737 621	1737 621
9-08-6	KEY		1	152 191	152 191	152 191	152 191	152 191

9-09-0 CRANKSHAFT BEARING PACKAGES

NOTE: When .001 thicker wall crankshaft main bearings are used for engines in production an identification mark is stamped on the machined surface of the crankshaft center counterweight for six cylinder engines and No. 3 counterweight for V8 cylinder engines. When the thicker wall crankshaft bearings are used the crankshaft will be marked M1, M2, M3, M4 or M5 depending on which journal has the .001 thicker wall bearing.

NOTE: Crankshaft Bearing Packages consist of one upper and one lower bearing.

9-09-2	BEARING PACKAGE, No. 1 Std.	6	1	2240 368	2240 368			
	No. 3 Std.	6	1	2240 372	2240 372			
	Nos. 2 and 4 Std.	6	2	2240 376	2240 376			
	No. 1 .001 U/S	6	1	2240 369	2240 369			
	No. 3 .001 U/S	6	1	2240 373	2240 373			
	Nos. 2 and 4 .001 U/S	6	2	2240 377	2240 377			
	No. 1 .002 U/S	6	1	2240 370	2240 370			
	No. 3 .002 U/S	6	1	2240 374	2240 374			
	Nos. 2 and 4 .002 U/S	6	2	2240 378	2240 378			
	No. 1 .003 U/S	6	1	2275 381	2275 381			
	No. 3 .003 U/S	6	1	2275 385	2275 385			
	Nos. 2 and 4 .003 U/S	6	2	2275 383	2275 383			
	No. 1 .010 U/S	6	1	2240 371	2240 371			
	No. 3 .010 U/S	6	1	2240 375	2240 375			
	Nos. 2 and 4 .010 U/S	6	2	2240 379	2240 379			
	No. 1 .012 U/S	6	1	2275 382	2275 382			
	No. 3 .012 U/S	6	1	2275 386	2275 386			

NOTE 1: Used only on RC2 with D-1 code Disc and stamped RR-38 on Ser. No. Pad.

★ Indicates use as required.

Numerals in parentheses () refer to notes.

Printed in U.S.A.

⊠ Indicates parts not listed in any previous parts book.

Prices and specifications subject to change without notice.

* Indicates change or addition.

1961 PASSENGER CAR PARTS CATALOG

CODE	PART NAME AND DESCRIPTION	C Y L.	PER CAR	VALIANT	PLYMOUTH	DESOTO	CHRYSLER	IMPERIAL
9-09-0 CRANKSHAFT BEARING PACKAGES - Cont'd								
9-09-2	BEARING PACKAGE - Cont'd							
	Nos. 2 and 4 .012 U/S	6	2	⊖2275 384	⊖2275 384			
	Nos. 1 and 2 and 4 Std.	8	3	----	2084 005			
	No. 3 Std.	8	1	----	1879 627			
	No. 5 Std.	8	1	----	1643 151			
	Nos. 1, 2 and 4 .001 U/S.	8	3	----	2084 006			
	No. 3 .001 U/S	8	1	----	1879 628			
	No. 5 .001 U/S	8	1	----	1643 152			
	Nos. 1, 2 and 4 .002 U/S	8	3	----	2084 007			
	No. 3 .002 U/S	8	1	----	1879 629			
	No. 5 .002 U/S	8	1	----	1643 153			
	Nos. 1, 2 and 4 .003 U/S	8	3	----	⊖2275 387			
	No. 3 .003 U/S	8	1	----	⊖2275 389			
	Nos. 1, 2 and 4 .010 U/S	8	3	----	2084 008			
	No. 3 .010 U/S	8	1	----	1879 630			
	No. 5 .010 U/S	8	1	----	1643 155			
	No. 1 Std., RP2 w/High Performance, RP2 w/Police Cars, RC1, RC2	8	1	----	2084 810	2084 810	2084 810	
	Nos. 2, 4 and 5 Std., RP2 w/High Performance, RP2 w/Police Cars, RC1, RC2	8	3	----	2084 833	2084 833	2084 833	
	No. 3 Std., RP2 w/High Performance, RP2 w/Police Cars, RC1, RC2	8	1	----	1818 524	1818 524	1818 524	
	No. 1 .001 U/S, RP2 w/High Performance, RP2 w/Police Cars, RC1, RC2	8	1	----	2084 811	2084 811	2084 811	
	Nos. 2, 4 and 5 .001 U/S, RP2 w/High Performance, RP2 w/Police Cars, RC1, RC2	8	3	----	2084 834	2084 834	2084 834	
	No. 3 .001 U/S, RP2 w/High Performance, RP2 w/Police Cars, RC1, RC2	8	1	----	1818 525	1818 525	1818 525	
	No. 1 .002 U/S, RP2 w/High Performance, RP2 w/Police Cars, RC1, RC2	8	1	----	2084 812	2084 812	2084 812	
	Nos. 2, 4 and 5 .002 U/S, RP2 w/High Performance, RP2 w/Police Cars, RC1, RC2	8	3	----	2084 835	2084 835	2084 835	
	No. 3 .002 U/S, RP2 w/High Performance, RP2 w/Police Cars, RC1, RC2	8	1	----	1818 526	1818 526	1818 526	
	No. 1 .003 U/S, RP2 w/High Performance, RP2 w/Police Cars, RC1, RC2	8	1	----	⊖2275 391	⊖2275 391	⊖2275 391	
	Nos. 2, 4 and 5 .003 U/S, RP2 w/High Performance, RP2 w/Police Cars, RC1, RC2	8	3	----	2275 393	2275 393	2275 393	
	No. 1 .010 U/S, RP2 w/High Performance, RP2 w/Police Cars, RC1, RC2	8	1	----	2084 813	2084 813	2084 813	
	Nos. 2, 4 and 5 .010 U/S, RP2 w/High Performance, RP2 w/Police Cars, RC1, RC2	8	3	----	2084 836	2084 836	2084 836	
	No. 3 .010 U/S, RP2 w/High Performance, RP2 w/Police Cars, RC1, RC2	8	1	----	1818 528	1818 528	1818 528	
	No. 1 .012 U/S, RP2 w/High Performance, RP2 w/Police Cars, RC1, RC2	8	1	----	⊖2275 392	⊖2275 392	⊖2275 392	
	Nos. 2, 4 and 5 .012 U/S, RP2 w/High Performance, RP2 w/Police Cars RC1, RC2	8	3	----	2275 394	2275 394	2275 394	

★ Indicates use as required. Numerals in parentheses () refer to notes. Printed in U.S.A.
 ⊖ Indicates parts not listed in any previous parts book. Prices and specifications subject to change without notice.
 May 31, 1961 Supersedes Jan. 6, 1961. * Indicates change or addition.

CODE	PART NAME AND DESCRIPTION	CYL	PER CAR	VALIANT	PLYMOUTH	DESOTO	CHRYSLER	IMPERIAL
9-09-0 CRANKSHAFT BEARING PACKAGES - Cont'd								
9-09-2	BEARING PACKAGE - Cont'd							
	No. 1 Std., RC2, RC3, RC4 . .	8	1	----	----	----	2084 814(1)	2084 814
	Nos. 2, 4 and 5 Std., RC2, RC3 RC4	8	3	----	----	----	2084 829(1)	2084 829
	No. 3 Std., RC2, RC3, RC4 . .	8	1	----	----	----	1879 378(1)	1879 378
	No. 1 .001 U/S, RC2, RC3, RC4 Nos. 2, 4 and 5 .001 U/S, RC2, RC3, RC4	8	1	----	----	----	2084 815(1)	2084 815
	No. 3 .001 U/S, RC2, RC3, RC4	8	3	----	----	----	2084 830(1)	2084 830
	No. 1 .002 U/S, RC2, RC3, RC4	8	1	----	----	----	1879 379(1)	1879 379
	Nos. 2, 4 and 5 .002 U/S, RC2, RC3, RC4	8	1	----	----	----	2084 816(1)	2084 816
	No. 3 .002 U/S, RC2, RC3, RC4 .	8	3	----	----	----	2084 831(1)	2084 831
	No. 1 .003 U/S, RC2, RC3, RC4	8	1	----	----	----	1879 380(1)	1879 380
	Nos. 2, 4 and 5 .003 U/S, RC3, RC4	8	1	----	----	----	E2275 395(1)	E2275 395(1)
	No. 1 .010 U/S, RC2, RC3, RC4	8	3	----	----	----	2275 397	2275 397
	Nos. 2, 4 and 5 .010 U/S, RC2, RC3, RC4	8	1	----	----	----	2084 817(1)	2084 817
	No. 3 .010 U/S, RC2, RC3, RC4	8	3	----	----	----	2084 832(1)	2084 832
	No. 1 .012 U/S RC2, RC3, RC4	8	1	----	----	----	1879 382(1)	1879 382
	Nos. 2, 4 and 5 .012 U/S, RC3, RC4	8	1	----	----	----	E2275 396(1)	E2275 396(1)
		8	3	----	----	----	2275 398	2275 398
9-10-0 CRANKSHAFT BEARING CAP								
9-10-2	PACKAGE, Crankshaft Bearing No. 5 Cap Oil Seal	8	1	----	1326 091			
9-10-5	SET, Crankshaft Bearing Cap Complete, w/225 cu. in. Aluminum Engine	6	1	*2275 442	*2275 442			
	CAP, No. 1	6	1	2084 403	2084 403			
		8	1	----	1643 168			
	RP2 w/High Performance, RP2 w/Police Cars, RC1, RC2 . . .	8	1	----	1879 327	1879 327	1879 327	
	RC2, RC3, RC4	8	1	----	----	----	1879 325(1)	1879 325
	CAP, No. 2	6	1	2084 403	2084 403			
		8	1	----	1643 168			
	RP2 w/High Performance, RP2 w/Police Cars, RC1, RC2 . . .	8	1	----	1879 327	1879 327	1879 327	
	RC2, RC3, RC4	8	1	----	----	----	1879 325(1)	1879 325
	CAP, No. 3	6	1	2084 405	2084 405			
		8	1	----	1643 169			
	RP2 w/High Performance, RP2 w/Police Cars, RC1, RC2 . . .	8	1	----	1879 328	1879 328	1879 328	
	RC2, RC3, RC4	8	1	----	----	----	1879 326(1)	1879 326
	CAP, No. 4	6	1	2084 404	2084 404			
		8	1	----	1643 168			
	RP2 w/High Performance, RP2 w/Police Cars, RC1, RC2 . . .	8	1	----	1879 327	1879 327	1879 327	
	RC2, RC3, RC4	8	1	----	----	----	1879 325(1)	1879 325
	CAP, No. 5	8	1	----	1643 170			
	RP2 w/High Performance, RP2 w/Police Cars, RC1, RC2 . . .	8	1	----	*1879 327(2)	*1879 327(2)	*1879 327(2)	
	RP2 w/High Performance, RP2 w/Police Cars, RC1, RC2, AFTER	8	1	----	E2206 315(2)	E2206 315(2)	E2206 315(2)	
	RC2, RC3, RC4, UP TO Note 2	8	1	----	----	----	*1879 325(1)	*1879 325(2)
	RC2, RC3, RC4, AFTER	8	1	----	----	----	E2206 316(2)	E2206 316(2)

NOTE 1: Used only on RC2 with D-1 code Disc and stamped RR-38 on Ser. No. Pad.

NOTE 2: Engine Nos. R36-11-2, R38-11-2 and R41-11-2.

★ Indicates use as required.

Numerals in parentheses () refer to notes.

Printed in U.S.A.

⊠ Indicates parts not listed in any previous parts book.

Prices and specifications subject to change without notice.

* Indicates change or addition.

CODE	PART NAME AND DESCRIPTION	CYL.	PER CAR	VALIANT	PLYMOUTH	DESOTO	CHRYSLER	IMPERIAL
9-10-0 CRANKSHAFT BEARING CAP - Cont'd								
9-10-19	SCREW	6	8	1408 867	1408 867			
	w/225 cu. in. Aluminum Engine	6	8	1947 147	1947 147			
		8	10	-----	1408 867	1408 867	1408 867	1408 867
9-11-0 CRANKSHAFT REAR BEARING OIL SEAL								
9-11-1	OIL SEAL PACKAGE	6	1	2084 411	2084 411			
	OIL SEAL PACKAGE, w/225 cu. in. Aluminum Engine	6	1	2240 650	2240 650			
	OIL SEAL PACKAGE, w/RETAINER, w/225 cu. in. Aluminum Engine	6	1	2240 651	2240 651			
		8	1	-----	1326 093			
	RP2 w/High Performance, RP2 w/Police Cars, UP TO	8	1	-----	1818 781(2)	1818 781(2)	1818 781(2)	1818 781(2)
	RP2 w/High Performance, RP2 w/Police Cars, AFTER	6	1	-----	2275 365(2)	2275 365(2)	2275 365(2)	2275 365(2)
9-11-7	RETAINER	6	1	1947 557	1947 557			
	RP2 w/High Performance, RP2 w/Police Cars	8	1	-----	1821 389	1821 389	1821 389	1821 389
9-11-8	SCREW, Retainer, w/225 cu.in. Aluminum Engine	6	2	455 866	455 866			
9-13-0 CRANKSHAFT VIBRATION DAMPER								
9-13-5	DAMPER	6	1	*2205 859	*2205 859			
	w/Std. Trans.	8	1	-----	1947 235			
	RP2 w/High Performance, RP2 w/Police Cars	8	1	-----	1947 897	1947 897	1947 897	1947 897
9-15-0 CAMSHAFT								
9-15-1	CAMSHAFT, UP TO	6	1	2128 644(1)	2128 644(1)			
	AFTER	6	1	2264 105(1)	2264 105(1)			
	w/225 cu.in. Aluminum Engine	6	1	2264 105	2264 105			
		8	1	-----	1947 016			
	w/Power Package	8	1	-----	1944 712			
	RP2 w/High Performance, RP2 w/Police Cars, RS1 w/High Performance, RS3 w/High Performance, RS3 w/Ram Manifold, RC4	8	1	-----	2129 203	2129 203	2129 203	
	RC1, RC2, RC3	8	1	-----	-----	1739 608	1739 608	1739 608
9-15-2	ECCENTRIC	8	1	-----	1618 718			
9-15-6	PLATE, Sprocket Thrust	8	1	-----	1946 992			
9-15-10	WASHER, Sprocket Retaining Screw	6	1	1739 607				
		8	1	-----	1618 732			
	RP2 w/High Performance, RP2 w/Police Cars	8	1	-----	1739 607	1739 607	1739 607	1739 607
9-16-0 CAMSHAFT BEARING								
9-16-6	BEARING, No. 1	6	1	2121 725	2121 725			
	No. 2	6	1	1821 772	1821 772			
	No. 3	6	1	2121 726	2121 726			
	No. 4	6	1	2121 727	2121 727			
	No. 1	8	1	-----	1632 522			
	No. 2	8	1	-----	1632 523			
	No. 3	8	1	-----	1632 524			
	No. 4	8	1	-----	1632 525			
	No. 5	8	1	-----	1632 526			

NOTE 1: Engine Nos. R17-11-15, R22-11-15.

NOTE 2: Engine Nos. R36-11-2, R38-11-2 and R41-11-2.

★ Indicates use as required.

Numerals in parentheses () refer to notes.

Printed in U.S.A.

☐ Indicates parts not listed in any previous parts book.

Prices and specifications subject to change without notice.

March 1, 1962 Supersedes May 31, 1961.

Page 9-12

* Indicates change or addition.

CODE	PART NAME AND DESCRIPTION	CYL.	PER CAR	VALIANT	PLYMOUTH	DESOTO	CHRYSLER	IMPERIAL
9-16-0 CAMSHAFT BEARING - Cont'd								
9-16-6	BEARING - Cont'd							
	No. 1, RP2 w/High Performance, RP2 w/Police Cars	8	1	----	1821 771	1821 771	1821 771	1821 771
	No. 2, RP2 w/High Performance, RP2 w/Police Cars	8	1	----	1821 772	1821 772	1821 772	1821 772
	No. 3, RP2 w/High Performance, RP2 w/Police Cars	8	1	----	1821 773	1821 773	1821 773	1821 773
	No. 4, RP2 w/High Performance, RP2 w/Police Cars	8	1	----	1821 774	1821 774	1821 774	1821 774
	No. 5, RP2 w/High Performance, RP2 w/Police Cars	8	1	----	1821 775	1821 775	1821 775	1821 775
9-16-17	PLUG, Camshaft Rear Bearing, w/225 cu. in. Aluminum Engine	6	1	1947 786	1947 786			
		8	1	*2120 059	*2120 059			
		8	1	----	1821 722			
	RP2 w/High Performance, RP2 w/Police Cars	8	1	----	1852 177	1852 177	1852 177	1852 177
9-17-0 CAMSHAFT SPROCKET								
9-17-5	SPROCKET	6	1	1947 560	1947 560			
		8	1	----	1618 666			
	RP2 w/High Performance, RP2 w/Police Cars w/one four Barrel Carburetor, RC1, RC2, RC3	8	1	----	1737 622	1737 622	1737 622	1737 622
	RP2 w/Police Cars w/Ram Manifold, RS3 w/Ram Manifold, RC4	8	1	----	2129 202	2129 202	2129 202	
9-17-13	SPACER	8	1	----	1618 717			
9-20-0 TIMING CHAIN								
9-20-1	CHAIN	6	1	1737 620	1737 620			
		8	1	----	1618 736			
	RP2 w/High Performance, RP2 w/Police Cars	8	1	----	1737 620	1737 620	1737 620	1737 620
9-23-0 CHAIN CASE COVER								
9-23-5	COVER	6	1	2203 106	2203 106			
		8	1	----	1944 773			
	RP2 w/High Performance, RP2 w/Police Cars	8	1	----	2120 627	2120 627	2120 627	2120 627
9-23-10	SCREW, w/WASHER	6	6	1407 234	1407 234			
		6	1	2121 573	2121 573			
	SCREW	8	3	----	180 122			
		8	1	----	180 137			
	RP2 w/High Performance, RP2 w/Police Cars	8	4	----	1407 234	1407 234	1407 234	1407 234
	RP2 w/High Performance, RP2 w/Police Cars	8	4	----	1945 404	1945 404	1945 404	1945 404
9-23-17	GASKET	6	1	1947 554	1947 554			
		8	1	----	*2129 012			
	RP2 w/High Performance, RP2 w/Police Cars	8	1	----	1945 173	1945 173	1945 173	1945 173
9-23-18	OIL SEAL	6	1	1947 581	1947 581			
		8	1	----	1618 683			
	RP2 w/High Performance, RP2 w/Police Cars	8	1	----	1737 771	1737 771	1737 771	1737 771

★ Indicates use as required.

Numerals in parentheses () refer to notes.

Printed in U.S.A.

☐ Indicates parts not listed in any previous parts book.

Prices and specifications subject to change without notice.

* Indicates change or addition.

Page 9-13

May 31, 1961 Supersedes Jan. 6, 1961.

1961 PASSENGER CAR PARTS CATALOG

ENGINE

CODE	PART NAME AND DESCRIPTION	CYL.	PER CAR	VALIANT	PLYMOUTH	DESOTO	CHRYSLER	IMPERIAL
9-23-0 CHAIN CASE COVER - Cont'd								
9-23-40	INDICATOR, Timing	6	1	2129 944	2129 944			
	Std. Trans.	8	1	----	1947 236			
	w/Automatic	8	1	----	1851 861			
9-31-0 CONNECTING ROD								
NOTE: Connecting Rod includes Bearing Cap, Bolt, Nut, Lockwasher and Bushing but does not include Bearing.								
9-31-4	ROD	6	6	1947 165	2205 552			
	w/225 cu. in. Engine	6	6	*2205 552				
		8	8	----	1944 866			
	RP2 w/High Performance, RP2 w/Police Cars, RC1, RC2	8	8	----	1737 690	1737 690	1737 690	
	RC2, RC3, RC4	8	8	----	----	----	1851 533(1)	1851 533
9-31-5	BOLT, Bearing Cap	6	12	1944 865	1944 865			
		8	16	----	1944 865			
	RP2 w/High Performance, RP2 w/Police Cars	8	16	----	1737 694	1737 694	1737 694	1737 694
9-31-7	NUT, Cap Bolt	8	★	1737 695	1737 695	1737 695	1737 695	1737 695
9-31-10	BUSHING	8	8	----	1618 701			
9-32-0 CONNECTING ROD BEARING PACKAGES								
NOTE: When .001 thicker wall connecting rod bearings are used for engines in production an identification mark is stamped on the machined surface of the crankshaft center counterweight for six cylinder engines and No. 3 counterweight for V8 cylinder engines. When the thicker wall connecting rod bearings are used the crankshaft will be marked R1, R2, R2, R4 or R5 depending on which journal has the .001 thicker wall bearing.								
NOTE: Connecting rod bearing packages consist of one upper and one lower bearing.								
9-32-2	BEARING PACKAGE, Std.	6	6	2084 360	2084 360			
	.001 U/S	6	6	2084 381	2084 381			
	.002 U/S	6	6	2084 382	2084 382			
	.003 U/S	6	6	⊠2275 411	⊠2275 411			
	.010 U/S	6	6	2084 383	2084 383			
	.012 U/S	6	6	⊠2275 412	⊠2275 412			
	Std.	8	8	----	1879 617			
	.001 U/S	8	8	----	1879 618			
	.002 U/S	8	8	----	1879 619			
	.010 U/S	8	8	----	1879 621			
	Std., RP2 w/High Performance, RP2 w/Police Cars	8	8	----	1818 698	1818 698	1818 698	1818 698
	.001 U/S, RP2 w/High Performance, RP2 w/Police Cars	8	8	----	1818 699	1818 699	1818 699	1818 699
	.002 U/S, RP2 w/High Performance, RP2 w/Police Cars	8	8	----	1818 700	1818 700	1818 700	1818 700
	.003 U/S, RP2 w/High Performance, RP2 w/Police Cars	8	8	----	1818 701	1818 701	1818 701	1818 701
	.010 U/S, RP2 w/High Performance, RP2 w/Police Cars	8	8	----	1818 702	1818 702	1818 702	1818 702
	.012 U/S, RP2 w/High Performance, RP2 w/Police Cars	8	8	----	1818 703	1818 703	1818 703	1818 703

NOTE 1: Used only on RC2 with D-I code Disc and stamped RR-38 on Ser. No. Pad.

★ Indicates use as required.

Numerals in parentheses () refer to notes.

Printed in U.S.A.

⊠ Indicates parts not listed in any previous parts book.
May 31, 1961 Supersedes Jan. 6, 1961.

Prices and specifications subject to change without notice.

* Indicates change or addition.

CODE	PART NAME AND DESCRIPTION	CYL	PER CAR	VALIANT	PLYMOUTH	DESOTO	CHRYSLER	IMPERIAL
9-34-0 PISTON, W/PIN								
NOTE: The following pistons include pin and pin retaining rings.								
9-34-5	PISTON, Std.	6	6	2084 384	2084 384			
	.005 O/S	6	6	2084 385	2084 385			
	.020 O/S	6	6	2084 386	2084 386			
	.040 O/S	6	6	2084 387	2084 387			
	Piston, Std., L. C. Export	6	6	2084 388	2084 388			
	.005 O/S, L. C. Export	6	6	2084 389	2084 389			
	.020 O/S, L. C. Export	6	6	2084 390	2084 390			
	PISTON, Std.	8	8	-----	1843 004			
	.005 O/S	8	8	-----	1843 005			
	.020 O/S	8	8	-----	1843 006			
	.040 O/S	8	8	-----	1843 007			
	PISTON, Std., L. C. Export	8	8	-----	1843 316			
	.005 O/S, L. C. Export	8	8	-----	1843 317			
	.020 O/S, L. C. Export	8	8	-----	1843 318			
	PISTON, Std., RP2 w/High Performance, RS1, RC1	8	8	-----	2240 333	2240 333	2240 333	
	.005 O/S, RP2 w/High Performance, RS1, RC1	8	8	-----	2240 334	2240 334	2240 334	
	.020 O/S, RP2 w/High Performance, RS1, RC1	8	8	-----	2240 335	2240 335	2240 335	
	.040 O/S, RP2 w/High Performance, RS1, RC1			-----	2240 336	2240 336	2240 336	
	PISTON, Std., RP2 w/Police Cars, RC2	8	8	-----	1879 333	-----	1879 333	
	.005 O/S, RP2 w/Police Cars, RC2	8	8	-----	1879 334	-----	1879 334	
	.020 O/S, RP2 w/Police Cars, RC2	8	8	-----	1879 335	-----	1879 335	
	.040 O/S, RP2 w/Police Cars, RC2	8	8	-----	1879 336	-----	1879 336	
	PISTON, Std., RC2	8	8	-----	-----	-----	1879 631(1)	
	.005 O/S, RC2	8	8	-----	-----	-----	1879 632(1)	
	.020 O/S, RC2	8	8	-----	-----	-----	1879 633(1)	
	.040 O/S, RC2	8	8	-----	-----	-----	1879 634(1)	
	PISTON, Std., RC3, RC4	8	8	-----	-----	-----	1879 337	1879 337
	.005 O/S, RC3, RC4	8	8	-----	-----	-----	1879 338	1879 338
	.020 O/S, RC3, RC4	8	8	-----	-----	-----	1879 339	1879 339
	.040 O/S, RC3, RC4	8	8	-----	-----	-----	1879 340	1879 340
	Piston, Std. L. C. Export, RC1	8	8	-----	-----	-----	2240 337	
	.005 O/S, L. C. Export, RC1	8	8	-----	-----	-----	2240 338	
	.010 O/S, L. C. Export, RC1	8	8	-----	-----	-----	2240 339	
	PISTON, Std., L. C. Export, RS1 w/High Performance, RS3, RC2	8	8	-----	-----	1879 648	1879 648	
	.005 O/S, L. C. Export, RS1 w/High Performance, RS3, RC2	8	8	-----	-----	1879 649	1879 649	
	.020 O/S, L. C. Export, RS1 w/High Performance, RS3, RC2	8	8	-----	-----	1879 650	1879 650	
	PISTON, Std., L. C. Export, RC3	8	8	-----	-----	-----	1879 636	1879 638
	.005 O/S, L. C. Export, RC3	8	8	-----	-----	-----	1879 639	1879 639
	.020 O/S, L. C. Export, RC3	8	8	-----	-----	-----	1879 640	1879 640

NOTE 1: Used only on RC2 with D-1 code Disc and stamped RR-38 on Ser. No. Pad.

★ Indicates use as required.

☐ Indicates parts not listed in any previous parts book.

* Indicates change or addition.

Numerals in parentheses () refer to notes.

1961 PASSENGER CAR PARTS CATALOG

ENGINE

CODE	PART NAME AND DESCRIPTION	CYL.	PER CAR	VALIANT	PLYMOUTH	DESOTO	CHRYSLER	IMPERIAL
9-35-0 PISTON RING SETS								
9-35-1	SET, Multi-Purpose, Std. to .009 O/S	6	1	2240 640	2240 640			
	.020 to .029 O/S	6	1	2275 453	2275 453			
	.040 to .049 O/S	6	1	2275 454	2275 454			
	Std. to .009 O/S	8	1	----	1752 588			
	.020 to .029 O/S	8	1	----	1752 589			
	.040 to .049 O/S	8	1	----	1752 590			
	Std. to .009 O/S, RP2 w/High Performance, RC1	8	1	----	1843 330	1843 330	1843 330	
	.020 to .029 O/S, RP2 w/High Performance, RC1	8	1	----	1843 331	1843 331	1843 331	
	.040 to .049 O/S, RP2 w/High Performance, RC1	8	1	----	1843 332	1843 332	1843 332	
	Std. to .009 O/S, RP2 w/Police Cars, RC2	8	1	----	1881 693	----	1881 693	
	.020 to .029 O/S, RP2 w/Police Cars, RC2	8	1	----	1881 694	----	1881 694	
	.040 to .049 O/S, RP2 w/Police Cars, RC2	8	1	----	1881 695	----	1881 695	
	Std. to .009 O/S, RC2	8	1	----	----	----	1881 696(1)	
	.020 to .029 O/S, RC2	8	1	----	----	----	1881 697(1)	
	.040 to .049 O/S, RC2	8	1	----	----	----	1881 698(1)	
	Std. to .009 O/S, RC3, RC4	8	1	----	----	----	1881 699	1881 699
	.020 to .029 O/S, RC3, RC4	8	1	----	----	----	1881 700	1881 700
	.040 to .049 O/S, RC3, RC4	8	1	----	----	----	1881 701	1881 701
9-36-0 PISTON PIN								
9-36-5	PIN, Std. w/o High Performance	8	8	----	*1618 738			
	.003 O/S, w/o High Performance	8	8	----	*1618 739			
	.008 O/S, w/o High Performance	8	8	----	*1618 740			
9-36-7	RING, Retaining	8	16	----	1324 470			
9-39-0 VALVE								
9-39-1	CASKET PACKAGE, Valve Grinding	6	1	2196 046	2196 046			
	w/225 cu. in. Aluminum Engine	6	1	2240 629	2240 629			
		8	1	----	2196 086			
	RP2 w/High Performance, RP2 w/Police Cars, RC1, RC2	8	1	----	1879 703	1879 703	1879 703	
	RC2, RC3, RC4	8	1	----	----	----	1879 704(1)	1879 704
9-39-5	VALVE, Intake, Std.	6	6	1947 623	1947 623			
	.005 O/S	6	6	2121 578	2121 578			
	.015 O/S	6	6	2121 579	2121 579			
	.030 O/S	6	6	2121 580	2121 580			
	Std.	8	8	----	1945 318			
	.005 O/S	8	8	----	1945 319			
	.015 O/S	8	8	----	1945 320			
	.030 O/S	8	8	----	1945 321			
	Std., RP2 w/High Performance, RP2 w/Police Cars	8	8	----	2206 103	2206 103	2206 103	2206 103
	.005 O/S, RP2 w/High Performance, RP2 w/Police Cars	8	8	----	2206 104	2206 104	2206 104	2206 104

NOTE 1: Used only on RC2 with D-1 code Disc and stamped RR-38 on Ser. No. Pad.

★ Indicates use as required.

Numerals in parentheses () refer to notes.

Printed in U.S.A.

⊠ Indicates parts not listed in any previous parts book.
March 1, 1962 Supersedes May 31, 1961.

Prices and specifications subject to change without notice.
* Indicates change or addition.

CODE	PART NAME AND DESCRIPTION	C Y L.	PER CAR	VALIANT	PLYMOUTH	DESOTO	CHRYSLER	IMPERIAL
9-39-0 VALVE - Cont'd								
9-39-5	VALVE - Cont'd.							
	.015 O/S, RP2 w/High Performance, RP2 w/Police Cars	8	8	-----	2206 105	2206 105	2206 105	2206 105
	.030 O/S, RP2 w/High Performance, RP2 w/Police Cars	8	8	-----	2206 106	2206 106	2206 106	2206 106
	Std., RC2	8	8	-----	-----	-----	1858 557(1)	
	.005 O/S, RC2	8	8	-----	-----	-----	1858 558(1)	
	.015 O/S, RC2	8	8	-----	-----	-----	1858 559(1)	
	.030 O/S, RC2	8	8	-----	-----	-----	1858 560(1)	
9-39-6	VALVE, Exhaust, Std.	6	6	1947 624	1947 624			
	.005 O/S	6	6	2121 581	2121 581			
	.015 O/S	6	6	2121 582	2121 582			
	.030 O/S	6	6	2121 583	2121 583			
	Std.	8	8	-----	1852 248			
	.005 O/S	8	8	-----	1637 563			
	.015 O/S	8	8	-----	1637 564			
	.030 O/S	8	8	-----	1637 565			
	Std., RP2 w/High Performance, RP2 w/Police Cars	8	8	-----	1737 698	1737 698	1737 698	1737 698
	.005 O/S, RP2 w/High Performance, RP2 w/Police Cars	8	8	-----	1739 612	1739 612	1739 612	1739 612
	.015 O/S, RP2 w/High Performance, RP2 w/Police Cars	8	8	-----	1739 613	1739 613	1739 613	1739 613
	.030 O/S, RP2 w/High Performance, RP2 w/Police Cars	8	8	-----	1739 614	1739 614	1739 614	1739 614
9-39-14	SHIELD, Intake Valve Stem Oil Exhaust Valve Stem Oil	6	6	1630 241	1630 241			
	Intake Valve Stem Oil	6	6	2128 977	2128 977			
	Valve Stem Oil, RP2 w/High Performance, RP2 w/Police Cars	8	8	-----	1630 241			
		8	16	-----	2121 586	2121 686	2121 686	2121 686
9-39-15	SPRING	6	12	1739 534	1739 534			
		8	16	-----	1739 534			
	w/DAMPER, RP2 w/High Performance, RP2 w/Police Cars, RC4	8	16	-----	1855 042	-----	1855 042	
	SPRING, RC1, RC2, RC3	8	16	-----	-----	1944 854	1944 854	1944 854
9-39-16	RETAINER, Valve Spring	6	12	1619 636	1619 636			
		8	16	-----	1619 636	1619 636	1619 636	1619 636
9-39-17	LOCK, Intake Valve Spring Retainer	6	12	381 875	381 875			
		8	16	-----	381 875	381 875	381 875	381 875
	Exhaust Valve Spring Retainer	6	12	1614 666	1614 666			
		8	16	-----	1614 666	1614 666	1614 666	1614 666
9-39-21	SPACER, Valve Spring	8	16	-----	1639 947			
	RP2 w/High Performance, RP2 w/Police Cars	8	16	-----	1859 144	1859 144	1859 144	1859 144
9-41-0 VALVE TAPPET								
9-41-1	SILENCER PACKAGE, Tappet Chamber, RP2 w/High Performance, RP2 w/Police Cars	8	1	-----	1879 747	1879 747	1879 747	1879 747
9-41-4	TAPPET, Std.	6	12	1739 356	1739 356			
	.001 O/S	6	12	1739 357	1739 357			
	.008 O/S	6	12	1739 358	1739 358			
	.030 O/S	6	12	*1739 359	*1739 359			

NOTE 1: Used only on RC2 with D-1 code Disc and stamped RR-38 on Ser. No. Pad.

★ Indicates use as required.

Numerals in parentheses () refer to notes.

Printed in U.S.A.

☐ Indicates parts not listed in any previous parts book.

Prices and specifications subject to change without notice.

* Indicates change or addition.

Page 9-17

May 31, 1961 Supersedes Jan. 6, 1961.

1961 PASSENGER CAR PARTS CATALOG

ENGINE

CODE	PART NAME AND DESCRIPTION	C Y L.	PER CAR	VALIANT	PLYMOUTH	DESOTO	CHRYSLER	IMPERIAL
9-41-0 VALVE TAPPET - Cont'd								
9-41-4	TAPPET - Cont'd.							
	Std.	8	16	----	1739 356			
	.001 O/S	8	16	----	1739 357			
	.008 O/S	8	16	----	1739 358			
	.030 O/S	8	16	----	2120 462			
	Std., RP2 w/High Performance, RP2 w/Police Cars	8	16	----	2084 029	2084 029	2084 029	2084 029
	.001 O/S, RP2 w/High Performance, RP2 w/Police Cars	8	16	----	2084 030	2084 030	2084 030	2084 030
	.008 O/S, RP2 w/High Performance, RP2 w/Police Cars	8	16	----	2084 031	2084 031	2084 031	2084 031
	.030 O/S, RP2 w/High Performance, RP2 w/Police Cars	8	16	----	2084 032	2084 032	2084 032	2084 032
9-41-12	RETAINER, Valve Tappet Plunger, RP2 w/High Performance, RP2 w/Police Cars	8	16	----	1489 340	1489 340	1489 340	1489 340
9-42-0 VALVE PUSH ROD								
9-42-1	ROD	6	12	1947 704				
	w/225 cu. m. Engine	6	12	*2120 514	*2120 514			
		8	16	----	1637 721			
	RP2 w/High Performance, RP2 w/Police Cars, RC1, RC2	8	16	----	1737 757	1737 757	1737 757	
	RC2, RC3, RC4	8	16	----	----	----	1851 669(1)	1851 669
9-43-0 VALVE ROCKER								
9-43-1	ROCKER	6	12	1947 594	1947 594			
	Intake Valve	8	8	----	1859 919			
	Exhaust Valve	8	8	----	1854 953			
	Right, RP2 w/High Performance, RP2 w/Police Cars	8	8	----	1737 646	1737 646	1737 646	1737 646
	Left, RP2 w/High Performance, RP2 w/Police Cars	8	8	----	1737 645	1737 645	1737 645	1737 645
9-43-3	SCREW, Adjusting	6	12	1855 238	1855 238			
		8	16	----	1855 238			
9-43-5	SPACER	6	6	2120 694	2120 694			
	RP2 w/High Performance, RP2 w/Police Cars	8	8	----	1737 756	1737 756	1737 756	1737 756
9-43-9	SHAFT	6	1	1947 614	1947 614			
		8	2	----	1618 671			
	RP2 w/High Performance, RP2 w/Police Cars	8	2	----	1821 393	1821 393	1821 393	1821 393
9-43-10	BRACKET, Shaft, End and Center, RP2 w/High Performance, RP2 w/Police Cars	8	6	----	1739 594	1739 594	1739 594	1739 594
	BRACKET, Shaft, Intermediate, RP2 w/High Performance, RP2 w/Police Cars	8	4	----	1739 595	1739 595	1739 595	1739 595
9-43-11	RETAINER, Shaft End and Intermediate	6	6	1947 616	1947 616			
	Retainer, Center	6	1	1947 617	1947 617			
9-43-14	SPRING, Shaft	8	8	----	1632 106			
9-43-19	PLUG, Shaft	6	2	1324 268	1324 268			
		8	4	----	1858 802			
	RP2 w/High Performance, RP2 w/Police Cars	8	4	----	1324 268	1324 268	1324 268	1324 268

NOTE 1: Used only on RC2 with D-1 code Disc and stamped RR-38 on Ser. No. Pad.

* Indicates use as required. Numerals in parentheses () refer to notes. Printed in U.S.A.
 † Indicates parts not listed in any previous parts book. Prices and specifications subject to change without notice.
 May 31, 1961 Supersedes Jan. 6, 1961. Page 9-18 * Indicates change or addition.

CODE	PART NAME AND DESCRIPTION	CYL.	PER CAR	VALIANT	PLYMOUTH	DESOTO	CHRYSLER	IMPERIAL
9-43-0 VALVE ROCKER - Cont'd								
9-43-23	WASHER, Shaft Bracket Screw, RP2 w/High Performance, RP2 w/Police Cars	8	10	----	1536 242	1536 242	1536 242	1536 242
9-43-26	SCREW, Shaft Bracket Locating	8	2	----	1670 476			
9-45-0 FLYWHEEL								
9-45-1	FLYWHEEL, w/Ring Gear . . .	6	1	1947 561	1947 561			
		8	1	----	2121 950			
	RP2 w/High Performance, RC1, 10 1/2" Clutch	8	1	----	2121 950	2121 950	2121 950	
	RP2 w/Police Cars, 11" Clutch	8	1	----	2128 768			
9-45-2	GEAR, Flywheel or Torque Converter Ring	6	1	2121 195	2121 195			
		8	1	----	1673 646	1673 646	1673 646	1673 646
9-45-6	BOLT	8	6	----	1557 704	1557 704	1557 704	1557 704
9-45-7	NUT	8	*	----	675 594	675 594	675 594	675 594
9-46-0 TORQUE CONVERTER								
9-46-4	TORQUE CONVERTER	6	1	2125 000	2125 000			
		8	1	----	1823 934			
	RP2 w/High Performance, RP2 w/Police Cars	8	1	----	1731 860	1731 860	1731 860	1731 860
9-46-8	PLATE, Drive	6	1	1949 763	1949 763			
9-46-10	STUD, Torque Converter Drive Flange	8	8	----	1061 157	1061 157	1061 157	1061 157
9-46-11	NUT, Torque Converter to Crankshaft Stud		*	----	675 594	675 594	675 594	675 594
9-46-21	SCREW, Drive Plate to Crankshaft	6	6	1949 424	1949 424			
	SCREW, Drive Plate	6	6	1949 765	1949 765			
9-46-31	OIL COOLER, Radiator Core, RC1, RC2	8	1	1903 792	1903 792	1903 792	1903 792	
	RC3, RC4	8	1	----	----	----	1903 791	1903 791
9-46-33	BRACKET, Transmission Oil Cooler Tube	8	1	----	1949 176	1949 176	1949 176	1949 176
9-46-43	NUT, Transmission Oil Cooler Tube Radiator End		2	1941 667	1941 667	1941 667	1941 667	1941 667
9-46-90	HOUSING	8	1	----	1824 334			
	RP2 w/High Performance, RP2 w/Police Cars	8	1	----	1736 436	1736 436	1736 436	1736 436
9-46-93	COVER, Housing	8	1	----	1854 314			
	RP2 w/High Performance, RP2 w/Police Cars	8	1	----	1823 548	1823 548	1823 548	1823 548
9-46-107	SCREW, w/WASHER, Cylinder Block to Torque Converter Housing	8	1	----	1854 523			
	RP2 w/High Performance, RP2 w/Police Cars	8	2	----	6012 042	6012 042	6012 042	6012 042
9-46-130	OIL SEAL, Impeller Hub	6	1	2124 705	2124 705			
	Heavy Duty	6	1	----	2124 705			
	w/PowerFlite Trans.	8	1	----	*1738 263	*1738 263	*1738 263	*1738 263
	w/TorqueFlite Trans.	8	1	----	E2400 084	E2400 084	E2400 084	E2400 084
9-46-137	PAN, Housing	8	1	----	1853 736			
9-46-229	SPRING, Overrunning Clutch . .	6	8	----	1942 187			
		8	8	----	1539 546	1539 546	1539 546	1539 546
9-48-0 MANIFOLD								
9-48-6	MANIFOLD, Exhaust	6	1	E2298 917	E2298 917			
	Right	8	1	----	2129 194			
	Left	8	1	----	2129 198			

★ Indicates use as required.

E Indicates parts not listed in any previous parts book.

* Indicates change or addition.

Numerals in parentheses () refer to notes.

1961 PASSENGER CAR PARTS CATALOG

ENGINE

CODE	PART NAME AND DESCRIPTION	CYL.	PER CAR	VALIANT	PLYMOUTH	DESOTO	CHRYSLER	IMPERIAL
9-48-0 MANIFOLD - Cont'd								
9-48-6	MANIFOLD - Cont'd. RP2 w/High Performance, RP2 w/Police Cars w/one four barrel Carburetor, RC1, RC2, RC3, Right	8	1	----	1854 990	1854 990	1854 990	1854 990
	RP2 w/High Performance, RP2 w/Police Cars w/one four barrel Carburetor, RC1, RC2, RC3, Left	8	1	----	1739 600	1739 600	1739 600	1739 600
	RP2 w/Police Cars w/Ram Manifold, RC4, Right	8	1	----	2205 853	----	2205 853	
	RP2 w/Police Cars w/Ram Manifold, RC4, Left	8	1	----	1947 432	----	1947 432	
9-48-7	MANIFOLD, Intake	6	1	2205 902	2205 902			
	w/one two barrel Carburetor.	8	1	----	1859 228			
	w/one four barrel Carburetor	8	1	----	1859 298			
	RP2 w/High Performance, RP2 w/Police Cars w/one four Barrel Carburetor, RS1 w/High Performance	8	1	----	1859 300	1859 300		
	RP2 w/Police Cars w/Ram Manifold, RC4, Right.	8	1	----	2240 395	----	2240 395	
	RP2 w/Police Cars w/Ram Manifold, RC4, Left	8	1	----	2240 394	----	2240 394	
	RC2	8	1	----	----	----	1851 899(1)	
	RC1, RC2	8	1	----	----	1859 299	1859 299	
	RC3	8	1	----	----	----	1858 623	1858 623
9-48-8	CONNECTOR, Vacuum Control		1	1858 955	1858 955	1858 955	1858 955	1858 955
9-48-12	STUD, Intake and Exhaust Manifold	6	13	2121 585	2121 585			
9-48-13	ELBOW, Intake Manifold Heat Inlet, RP2 Police Cars, w/Ram Manifold	8	2	----	1947 732			
	RC4	8	2	----	----	----	1947 430	
9-48-14	WASHER, Intake and Exhaust Manifold Stud	6	11	2121 223	2121 223			
	Intake and Exhaust Manifold Stud	6	2	2206 416	2206 416			
9-48-27	REINFORCEMENT, Intake Manifold Gasket End, RP2 w/High Performance, RP2 w/Police Cars, RC1, RC2	8	2	----	1859 332	1859 332	1859 332	
	RC2, RC3, RC4	8	1	----	----	----	1851 665(1)	1851 665
9-48-40	SCREW, Intake Manifold w/o Air Condition	8	8	----	1859 465			
	w/o Air Condition	8	8	----	1859 466			
	w/Air Condition	8	1	----	1821 174			
	w/Air Condition	8	1	----	1821 178			
	w/Air Condition	8	7	----	1859 465			
	w/Air Condition	8	7	----	1859 466			
	RP2 w/High Performance, RP2 w/Police Cars	8	*	----	2120 468	2120 468	2120 468	2120 468
	RP2 w/High Performance, RP2 w/Police Cars	8	*	----	2120 467	2120 467	2120 467	2120 467
9-48-43	STUD, Exhaust Manifold	8	16	----	1613 782			
	RP2 w/High Performance, RP2 w/Police Cars	8	13	----	1613 782	1613 782	1613 782	1613 782
9-48-44	NUT, Exhaust Manifold Stud	6	2	1947 753	1947 753			
		8	12	----	1737 695	1737 695	1737 695	1737 695
9-48-45	WASHER, Exhaust Manifold Stud Nut	6	2	1947 752	1947 752			
9-48-56	SHIELD, Intake Manifold Heat	8	1	----	1619 627			

NOTE 1: Used only on RC2 with D-1 code Disc and stamped RR-38 on Ser. No. Pad.

CODE	PART NAME AND DESCRIPTION	CYL.	PER CAR	VALIANT	PLYMOUTH	DESOTO	CHRYSLER	IMPERIAL
9-48-0 MANIFOLD - Cont'd								
9-48-124	ELBOW, Intake Manifold Heat Inlet, RP2 w/Police Cars w/Ram Manifold	8	2	----	1947 732	----	1947 430	
	RC4	8	2	----	----	----		
9-48-151	TUBE, Intake Manifold Equalizer, RP2 w/Police Cars w/Ram Manifold, RC4	8	1	----	2206 153	----	2206 153	<i>Tube</i>
9-48-152	COUPLING, Intake Manifold Equalizer Tube, RP2 w/Police Cars w/Ram Manifold, RC4	8	2	----	1947 403	----	1947 403	<i>rubber hose</i>
9-48-153	CLAMP, Intake Manifold Equalizer Tube Coupling, RP2 w/Police Cars w/Ram Manifold, RC4	8	1	----	870 469	----	870 469	
9-48-158	COVER, Exhaust Cross Over, Right, RP2 w/Police Cars w/Ram Manifold, RC4	8	1	----	2120 757	----	2120 757	
	Left, RP2 w/Police Cars w/Ram Manifold, RC4	8	1	----	2120 057	----	2120 057	
9-50-0 MANIFOLD GASKETS								
9-50-1	GASKET SET	6	1	2084 416	2084 416			
		8	1	----	2084 347			
9-50-3	GASKET, Intake to Exhaust Manifold	6	1	2206 120	2206 120			
9-50-4	GASKET, Intake Manifold Heat Inlet Elbow, RP2 w/Police Cars w/Ram Manifold, RC4	8	2	----	1947 429	----	1947 429	
9-50-5	GASKET, Exhaust Manifold	8	1	----	1670 508			
9-50-6	GASKET, Intake Manifold, RP2 w/High Performance, RP2 w/Police Cars, RC1, RC2	8	1	----	1737 709	1737 709	1737 709	
	RC2, RC3, RC4	8	1	----	----	----	1851 664(1)	1851 664
9-50-16	GASKET, Intake Manifold Heat Inlet Elbow to Exhaust Manifold, RP2 w/Police Cars w/Ram Manifold, RC4	8	2	----	1947 428	----	1947 428	
9-58-0 MANIFOLD HEAT CONTROL VALVE THERMOSTAT								
9-58-1	PACKAGE, Manifold Heat Control	6	1	2084 797	2084 797			
		8	1	----	2240 684			
	RP2 w/High Performance, RP2 w/Police Cars w/one four Barrel Carburetor, RC1, RC2, RC3	8	1	----	2084 794	2084 794	2084 794	2084 794
	RP2 w/Police Cars w/Ram Manifold, RC4, Right	8	1	----	2196 074	----	2196 074	
	RP2 w/Police Cars w/Ram Manifold, RC4, Left	8	1	----	2084 795	----	2084 795	
9-58-5	THERMOSTAT	6	1	2121 554	2121 554			
	RP2 w/Police Cars w/Ram Manifold, RC4	8	2	----	2128 933	----	2128 933	
	RC1, RC2, RC3	8	1	----	960 003	960 003	960 003	960 003
9-58-12	COUNTERWEIGHT	6	1	2121 430	2121 430			
	SHIELD, RC1, RC2, RC3	8	1	----	1670 515	1670 515	1670 515	1670 515
	RP2 w/Police Cars w/Ram Manifold, RC4, Right	8	1	----	1670 515	----	1670 515	
	RP2 w/Police Cars w/Ram Manifold, RC4, Left	8	1	----	1944 616	----	1944 616	

NOTE 1: Used only on RC2 with D-1 code Disc and stamped RR-38 on Ser. No. Pad.

★ Indicates use as required.

Numerals in parentheses () refer to notes.

Printed in U.S.A.

☐ Indicates parts not listed in any previous parts book.

Prices and specifications subject to change without notice.

* Indicates change or addition.

1961 PASSENGER CAR PARTS CATALOG

ENGINE

CODE	PART NAME AND DESCRIPTION	CYL.	PER CAR	VALIANT	PLYMOUTH	DESOTO	CHRYSLER	IMPERIAL
9-58-0 MANIFOLD HEAT CONTROL VALVE THERMOSTAT - Cont'd								
9-58-13	BOLT, RC1, RC2, RC3 RP2 w/Police Cars w/Ram Manifold, RC4	8	2	1736 012	1736 012	1736 012	1736 012	1736 012
9-58-14	LOCK, RC1, RC2, RC3 RP2 w/Police Cars w/Ram Manifold, RC4	8	2	1409 594	1409 594	1409 594	1409 594	1409 594
9-59-0 MANIFOLD HEAT CONTROL VALVE								
9-59-13	SPRING, RC1, RC2, RC3 RP2 w/Police Cars w/Ram Manifold, RC4	8	2	1558 897	1558 897	1558 897	1558 897	1558 897
9-59-15	PIN, Spring, RC1, RC2, RC3 RP2 w/Police Cars w/Ram Manifold, RC4	8	2	1639 597	1639 597	1639 597	1639 597	1639 597
9-62-0 MANIFOLD HEAT CONTROL VALVE STOP								
9-62-1	STOP RP2 w/Police Cars w/Ram Manifold RC4 RC1, RC2, RC3	6	1	2121 455	2121 455			
		8	2	----	683 057	----	683 057	
		8	1	----	683 057	683 057	683 057	683 057
9-64-0 ENGINE FRONT SUPPORT								
9-64-5	SUPPORT, Right Left RP2 w/High Performance, RP2 w/Police Cars, RC1, RC2, Right RP2 w/High Performance, RP2 w/Police Cars, RC1, RC2, Left RC3, RC4, Right RC3, RC4, Left	8	1	----	2120 236			
		8	1	----	2120 232			
		8	1	----	2120 238	2120 238	2120 238	
		8	1	----	2120 237	2120 237	2120 237	
		8	1	----	----	----	2128 572	2128 572
		8	1	----	----	----	2128 571	2128 571
9-64-12	SCREW, Engine Front Support Heat Shield	6	1	1947 301	1947 301			
9-64-13	STUD, Engine Front Support to Frame		2	2128 773	2128 773	2128 773	2128 773	2128 773
9-64-17	NUT, Engine Front Support to Frame Stud		2	2202 834	2202 834	2202 834	2202 834	2202 834
9-64-18	WASHER, Engine Front Support to Frame Stud		2	2128 774	2128 774	2128 774	2128 774	2128 774
9-64-22	SIELD, Engine Front Support Heat, Left Right Left RP2 w/High Performance, RP2 w/Police Cars, Right RP2 w/High Performance, RP2 w/Police Cars	6	1	2128 999	2128 999			
		8	1	----	2128 943			
		8	1	----	2128 944			
		8	1	----	2128 935	2128 935	2128 935	2128 935
		8	1	----	2128 936	2128 936	2128 936	2128 936
9-64-24	BRACKET, Engine Front Support Insulator, Right, w/225 cu. in. Engine Left w/225 cu. in. Engine	6	1	E2203 062				
		6	1	E2203 063				
9-67-0 ENGINE FRONT SUPPORT INSULATOR								
9-67-4	INSULATOR, Right Left Right Left Right, w/225 cu. in. Engine Left, w/225 cu. in. Engine	6	1	2203 039				
		6	1	2203 040				
		6	1	----	2128 479			
		6	1	----	2128 821			
		6	1	E2264 119				
		6	1	E2264 140				

★ Indicates use as required. Numerals in parentheses () refer to notes. Printed in U.S.A.
 E Indicates parts not listed in any previous parts book. Prices and specifications subject to change without notice.
 May 31, 1961 Supersedes Jan. 6, 1961. * Indicates change or addition.

CODE	PART NAME AND DESCRIPTION	C Y L.	PER CAR	VALIANT	PLYMOUTH	DESOTO	CHRYSLER	IMPERIAL
9-67-0 ENGINE FRONT SUPPORT INSULATOR - Cont'd								
9-67-9	SCREW, Engine Front Support Insulator to Cylinder Block . .	6	1	2206 288	2206 288			
	STUD, Engine Front Support Insulator to Cylinder Block . .	6	1	6022 799	6022 799			
9-67-19	ADAPTER, Engine Front Support Insulator Right, w/225 cu. in. Engine	6	1	E2264 130				
	Left, w/225 cu. in. Engine . .	6	1	E2264 131				
9-69-0 FRAME ENGINE REAR SUPPORT CROSSMEMBER								
9-69-4	CROSSMEMBER, w/Automatic Trans.	6	1	----	2123 346			
	RC1, RC2		1	----	2122 578	2122 578	2122 578	
	RC3, RC4	8	1	----	----	----	2122 575	
		8	1	----	----	----	----	1829 984
9-69-6	BRACKET, Frame Engine Rear Support Crossmember, Right, Cv. Cp.	8	1	----	----	----	----	1940 300
	Left, Cv. Cp.	8	1	----	----	----	----	1940 301
9-69-28	SCREW, w/WASHER w/Automatic Trans.	6	2	----	2200 024			
	Trans.	6	2	----	2200 024			
9-70-0 FRAME ENGINE REAR SUPPORT CROSSMEMBER BRACKET								
9-70-9	NUT, Frame Engine Rear Support Crossmember to Bracket Bolt		4	----	1946 141	1946 141	1946 141	
9-71-0 ENGINE REAR SUPPORT INSULATOR								
9-71-5	INSULATOR	6	1	2074 404				
	w/225 cu. in. Engine	6	1	E2206 957				
	w/Std. Trans.	6	1	----	1739 090			
	w/Automatic Trans.	6	1	----	1946 362			
	RY1 except Cv. Cp.	8	1	----	1734 529	1734 529	1734 529	1734 529
	Cv. Cp.	8	1	----	----	----	----	1533 850
9-71-8	NUT, Engine Rear Support Insulator Stud		1	6022 805	6022 805	6022 805	6022 805	
9-71-15	STOP		1	----	2122 280	2122 280	2122 280	
	BUMPER, w/225 cu.in. Engine .	6	1	E2206 965				
9-71-16	SPRING		1	----	2122 278	2122 278	2122 278	
9-71-17	PLATE, Spring		1	----	2122 277	2122 277	2122 277	
9-71-18	STUD, w/WASHER		1	----	2122 275	2122 275	2122 275	
9-71-19	WASHER, Stud, Upper		1	----	2122 279	2122 279	2122 279	

NOTES
