

GROUP 7 - COOLING

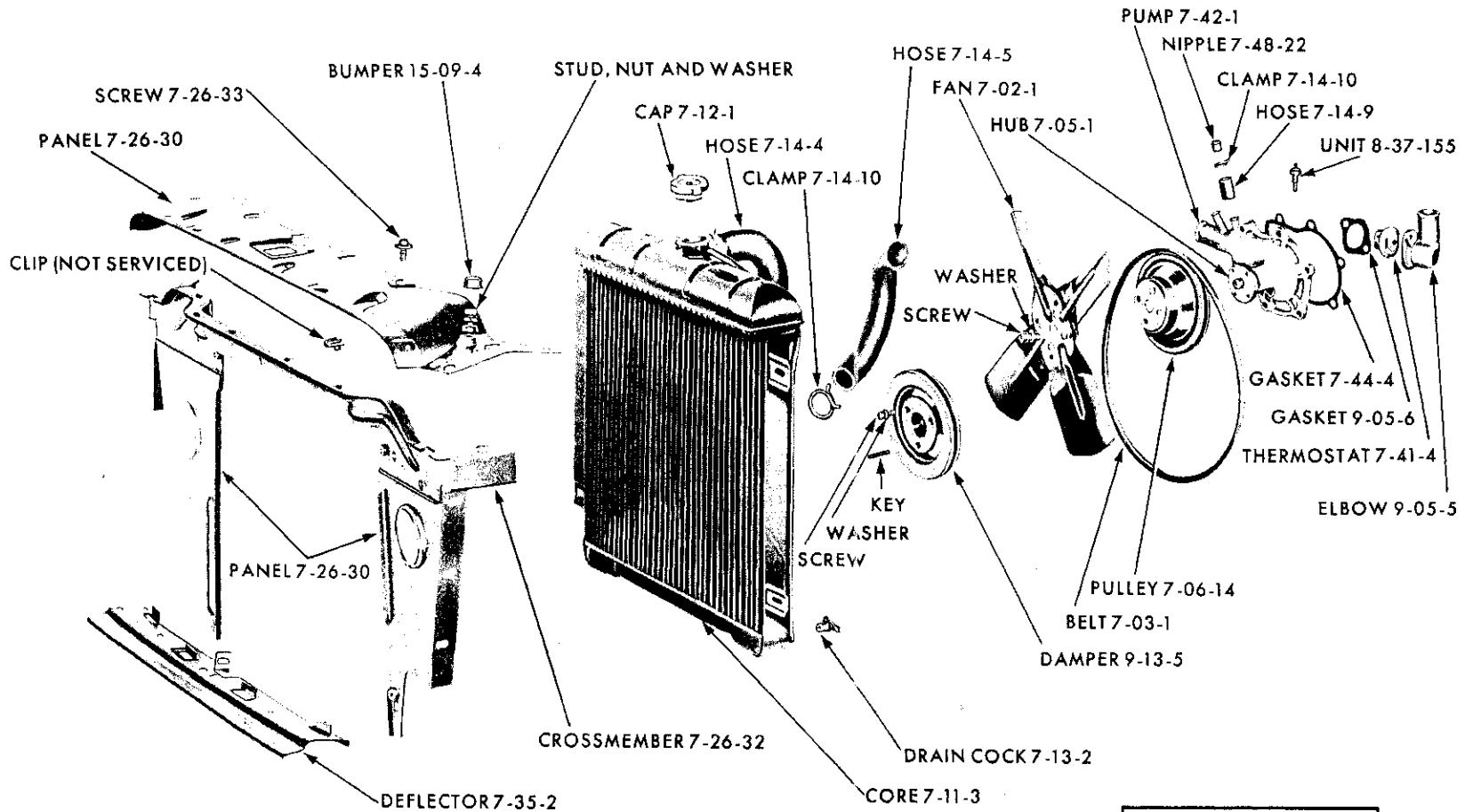

PARTS INDICATED  
BY NAME ONLY - ORDER  
BY DESCRIPTION

19x8844B

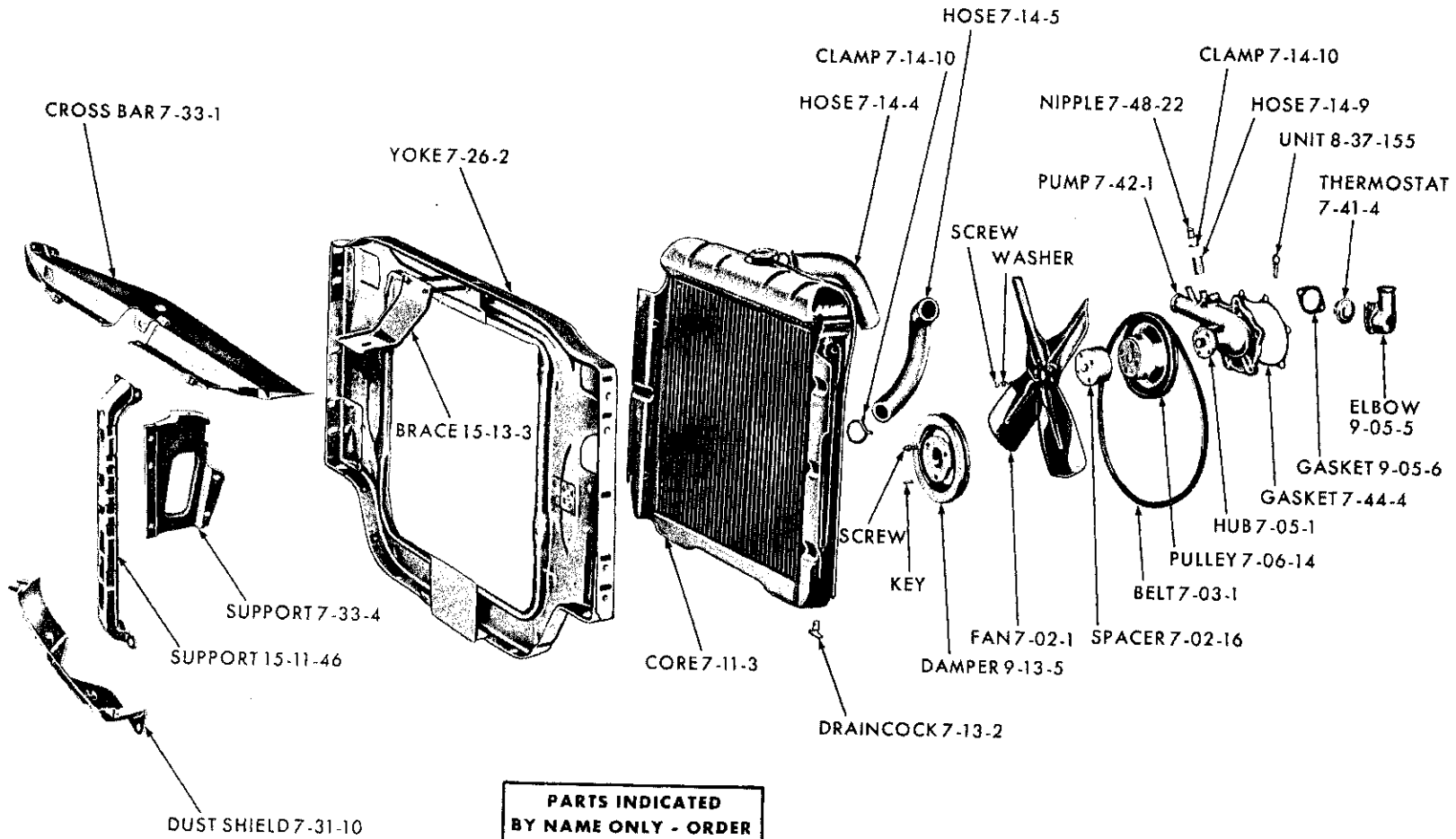

19x9016

COOLING SYSTEM - PLYMOUTH RP1

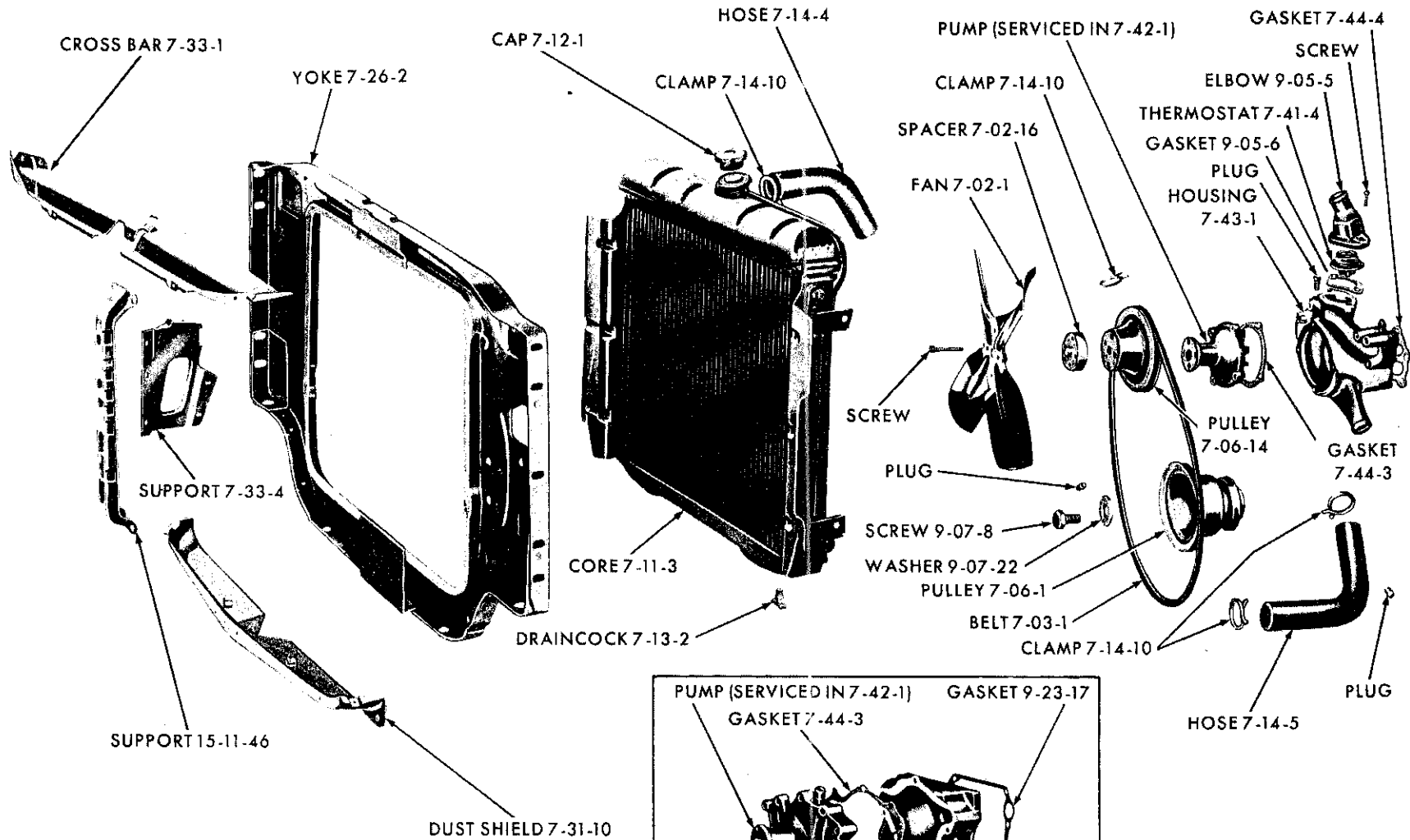

**PARTS INDICATED  
BY NAME ONLY - ORDER  
BY DESCRIPTION**

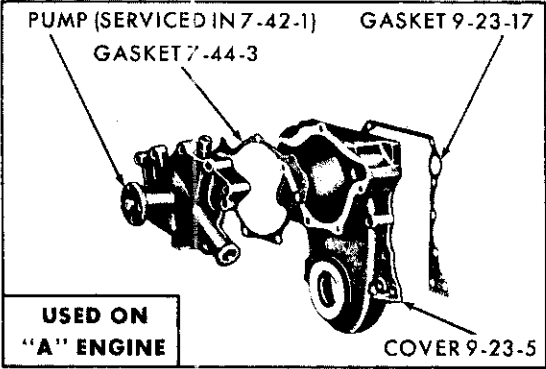

19x9017

COOLING SYSTEM - PLYMOUTH RP2

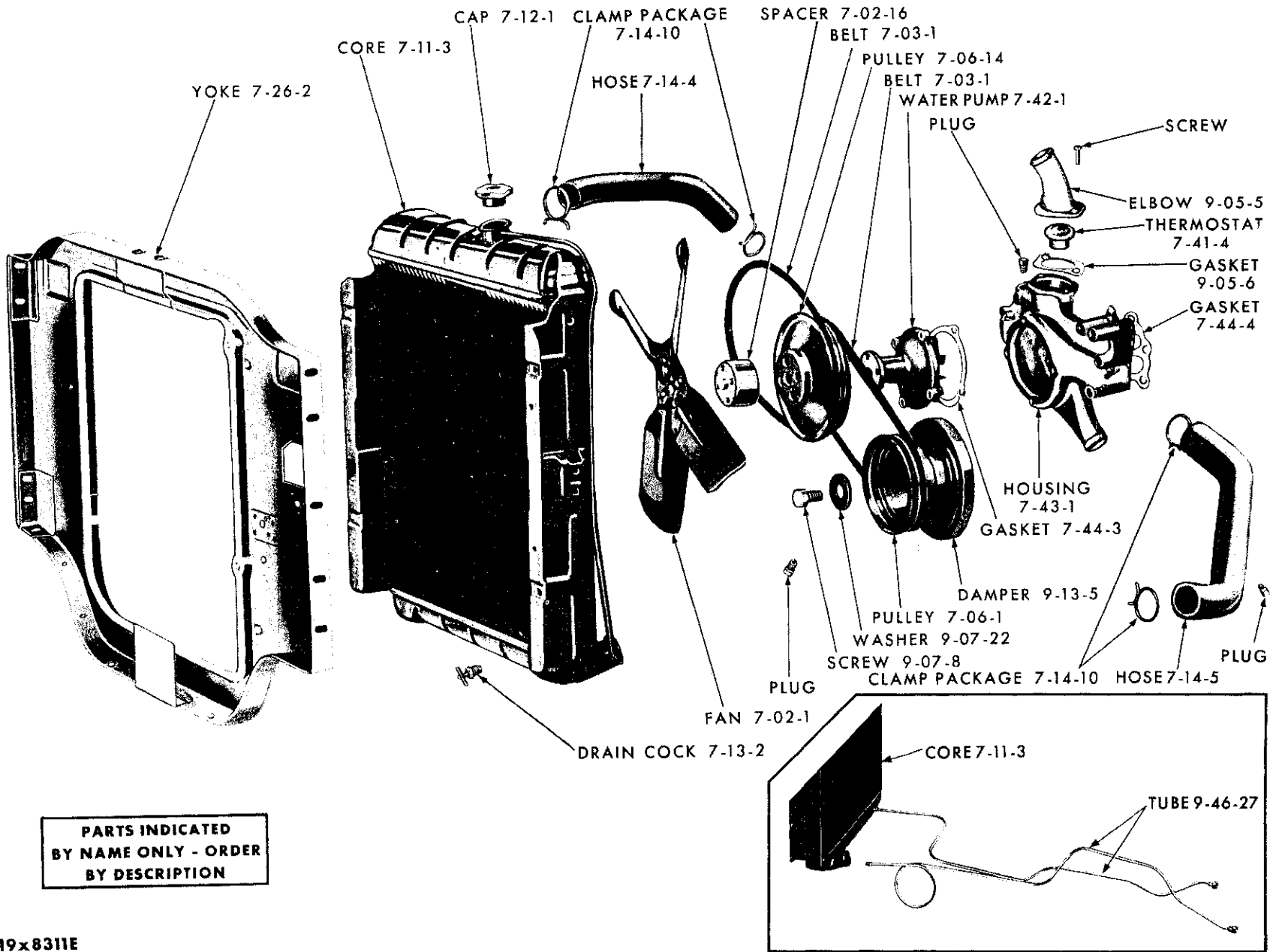

19x8311E

COOLING SYSTEM - DESOTO RS1, CHRYSLER RC1-2-3-4 AND IMPERIAL RY1

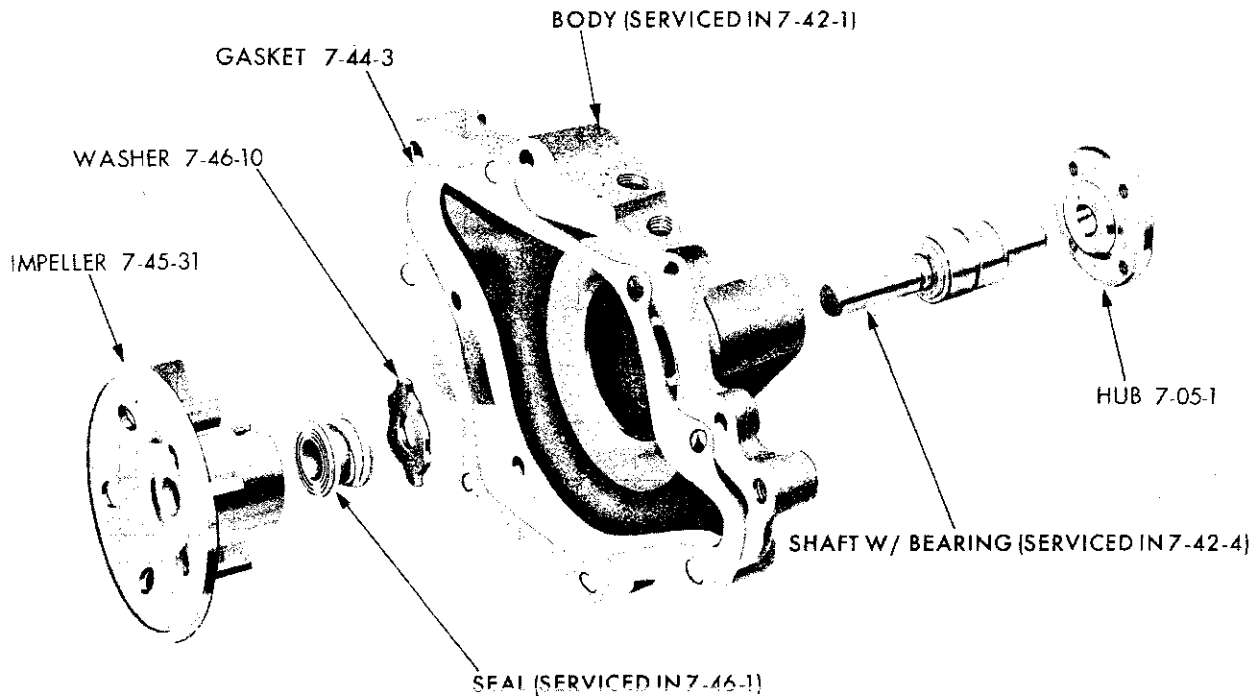

19x6902D

WATER PUMP - USED WITH "A" ENGINE

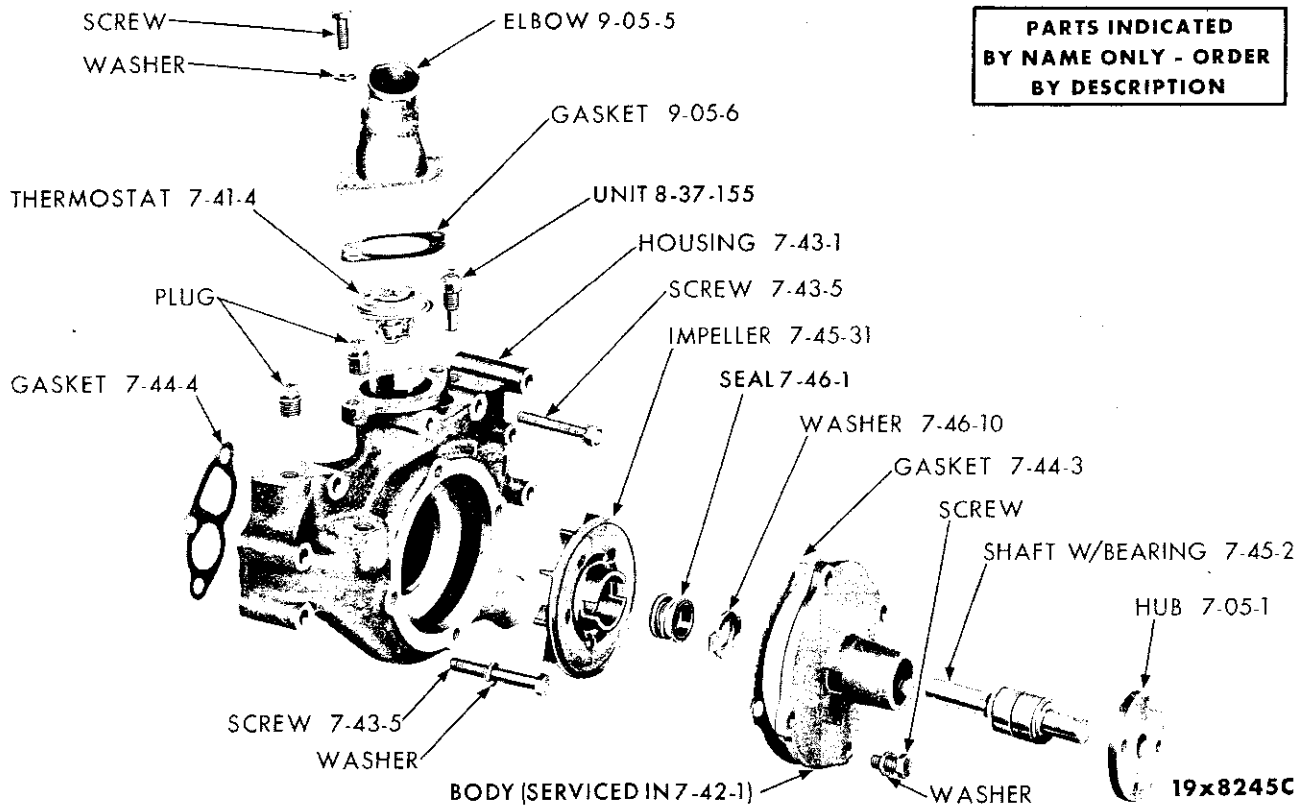

WATER PUMP - USED WITH "B" ENGINE

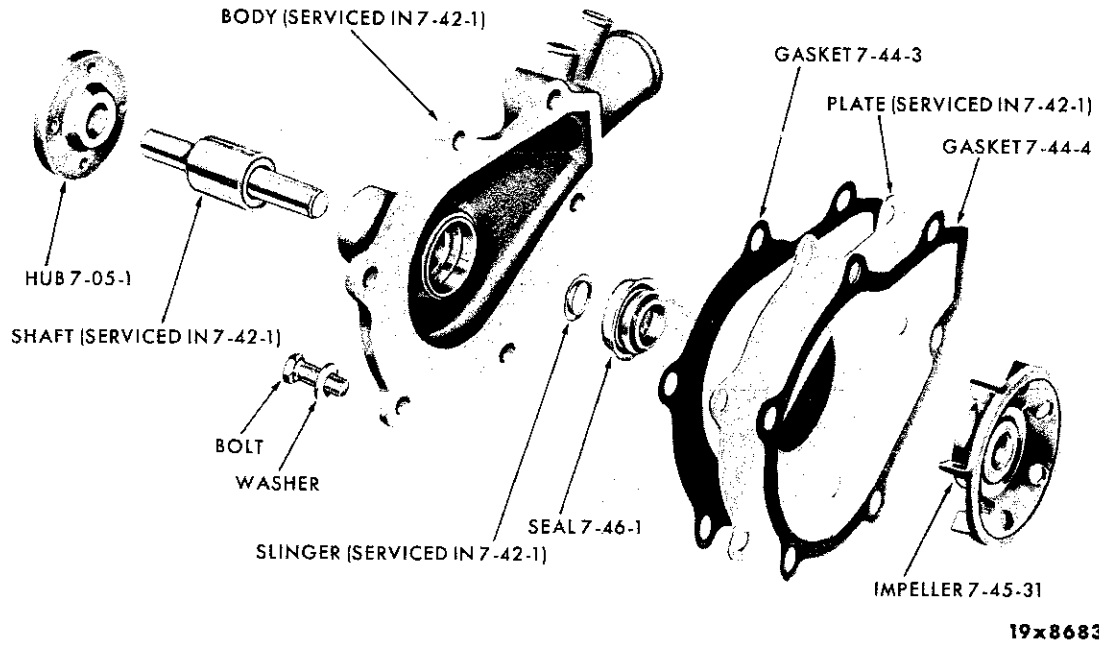

WATER PUMP - 6 CYLINDER

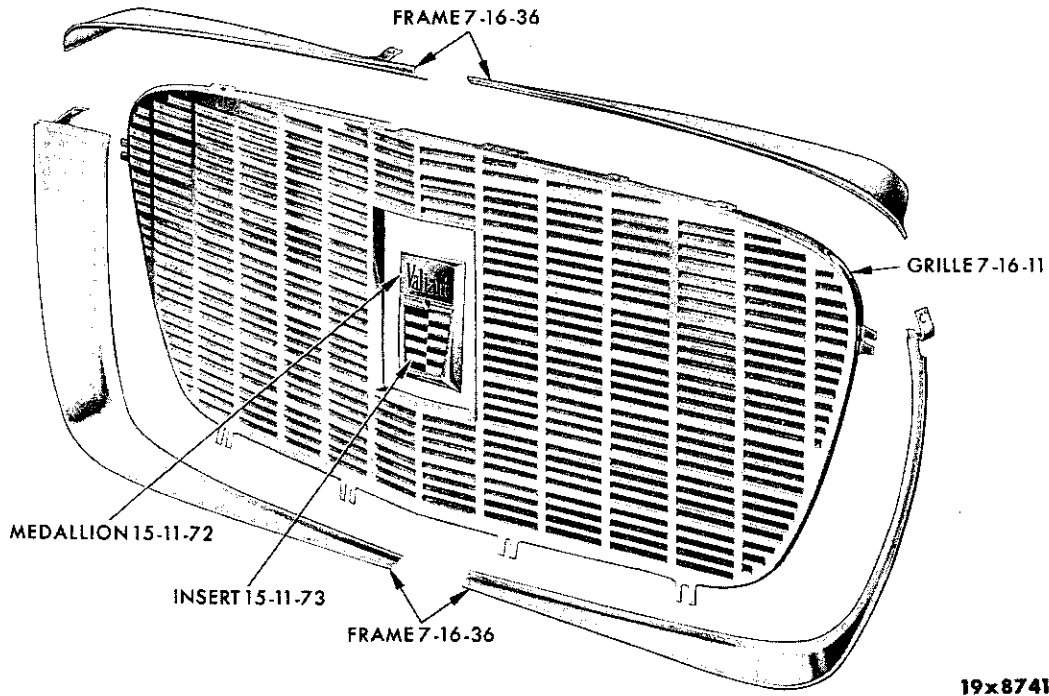

GRILLE - VALIANT RV1

COOLING

# 1961 PASSENGER CAR PARTS CATALOG

Page 7-3

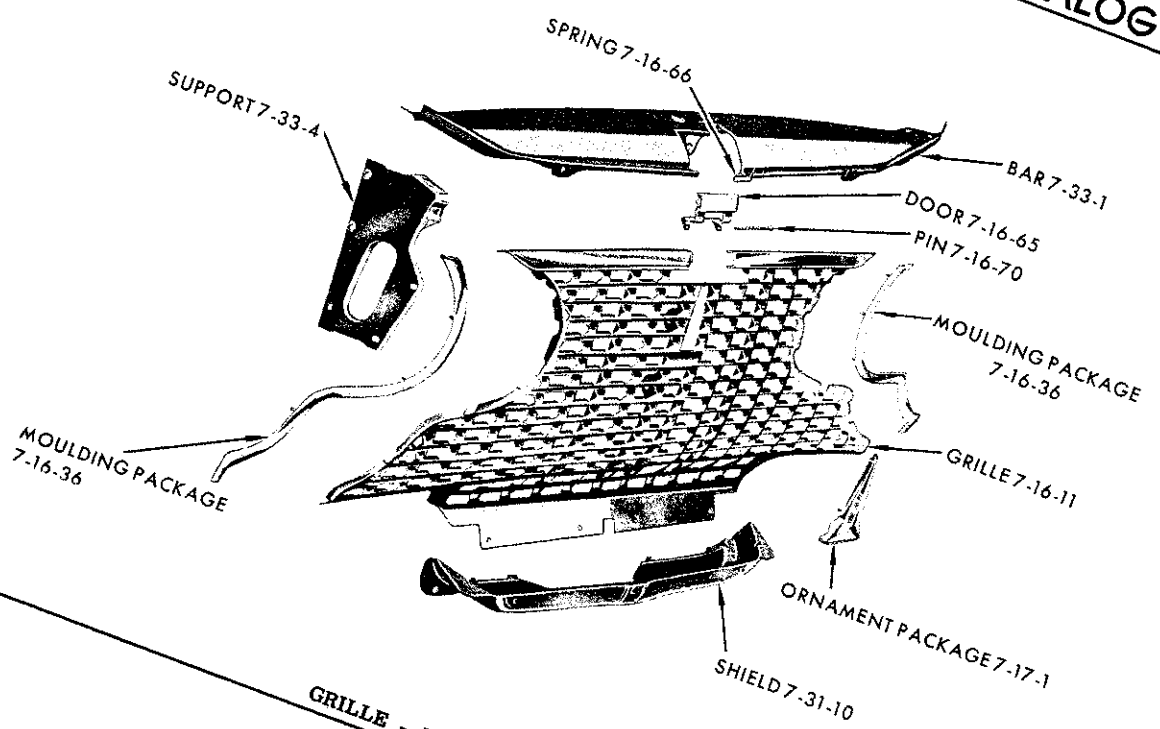

GRILLE - PLYMOUTH RP1-2

19x8975

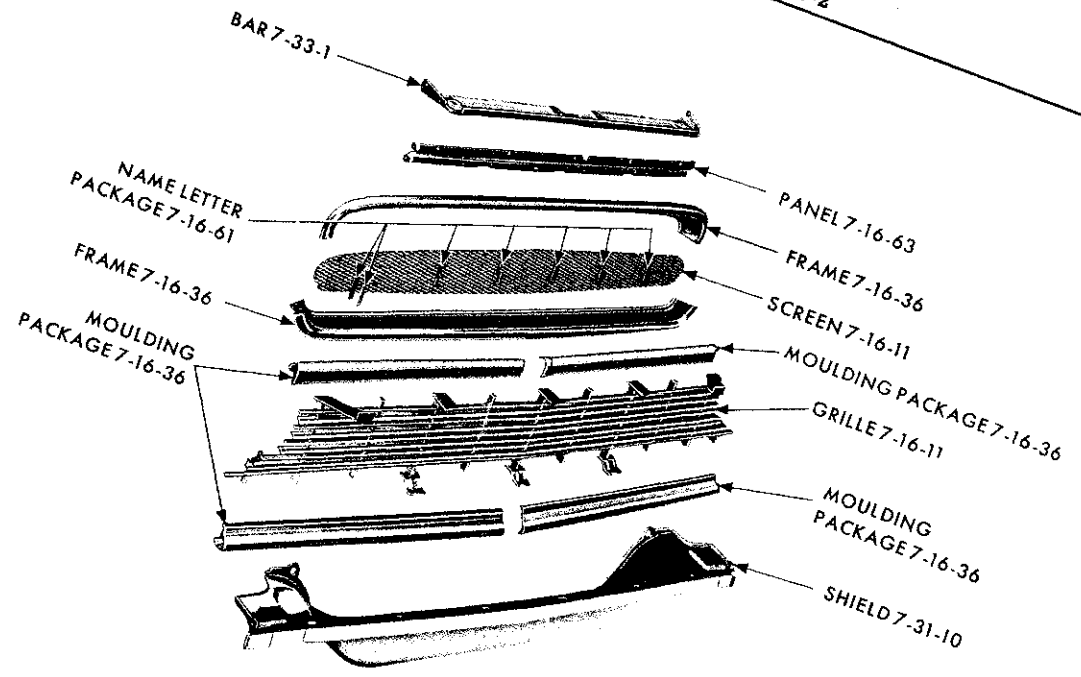

GRILLE - DESOTO RS1  
Page 7-3

19x8962

Printed in U.S.A.

October 3, 1960.

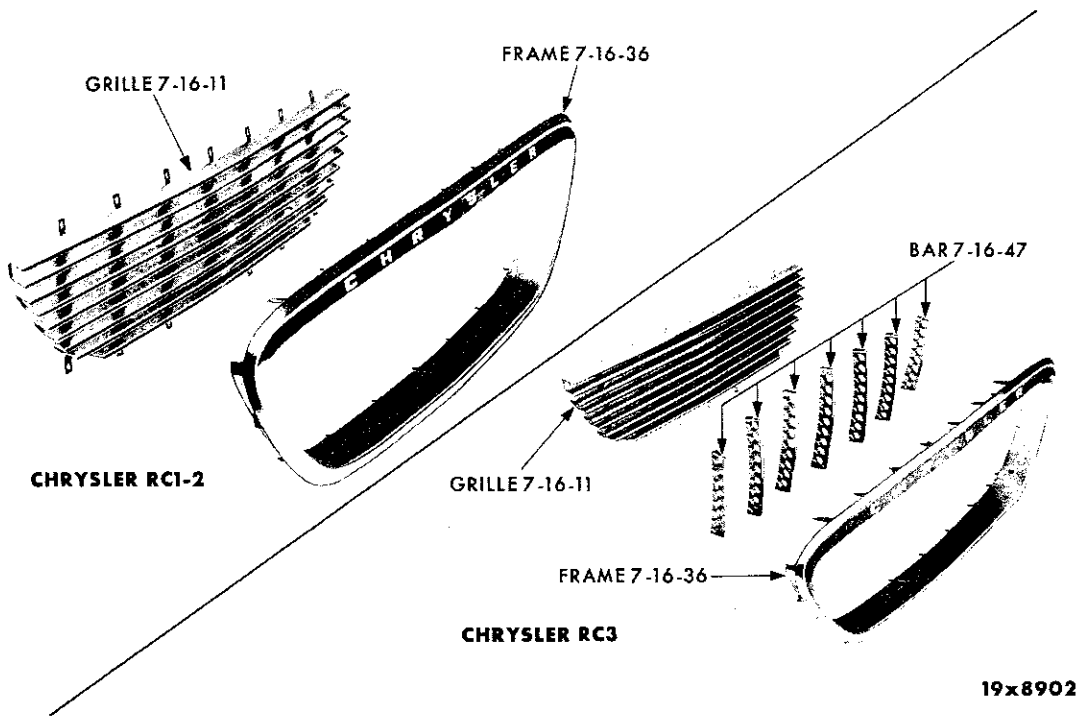

GRILLE - CHRYSLER RC1-2-3

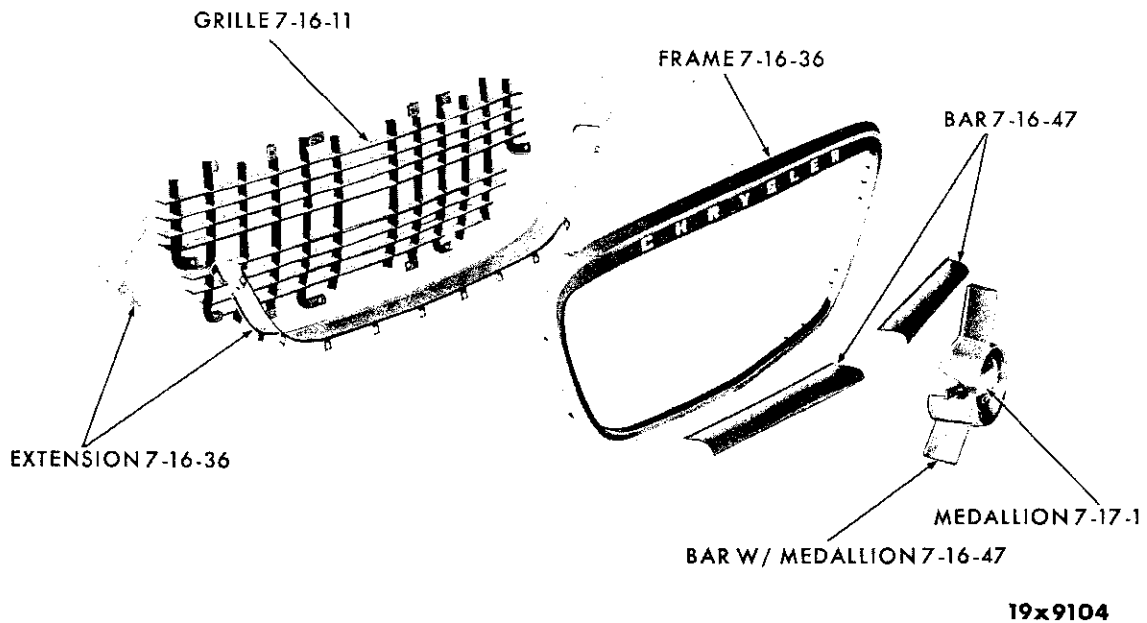

GRILLE - CHRYSLER RC4







CODE	PART NAME AND DESCRIPTION	C Y L.	PER CAR	VALIANT	PLYMOUTH	DESOTO	CHRYSLER	IMPERIAL
<b>7-02-0 FAN ASSEMBLY</b>								
7-02-1	FAN . . . . .	6	1	2121 971				
	w/o Air Conditing . . . . .	6	1	----	1947 907			
	w/Air Conditioning . . . . .	6	1	----	1735 939			
	w/Air Conditioning . . . . .	8	1	----	2120 208			
	Heavy Duty, RP2, RC1 . . . . .	8	1	----	1735 941	----	1735 941	
	w/o Air Conditioning . . . . .	8	1	----	1735 939	1735 939	1735 939	1735 939
	w/Air Conditioning, RP2, High Performance, RC1, RC2 . . . . .	8	1	----	2121 013	2121 013	2121 013	
	RC3, RC4, RY1 . . . . .	8	1	----	----	----	2121 014	2121 014
	w/Model F Air Conditioning . . . . .	6	1	2206 356	1735 941			
		8	1	----	1985 513	1985 513	1985 513	1985 513
7-02-16	SPACER . . . . .	6	1	----	1730 155			
		8	1	----	2120 130			
	w/o Air Conditioning, RP2, High Performance, RC1, RC2 . . . . .	8	1	----	2120 510	2120 510	2120 510	
	RC3, RC4, RY1 . . . . .	8	1	----	----	----	1674 746	1674 746
	w/Model F Air Conditioning, RP2 High Performance . . . . .	8	1	----	1730 155	1730 155	1730 155	1730 155
<b>7-03-0 FAN AND RELATED DRIVE BELTS</b>								
7-03-1	BELT, Engine to Alternator to Fan, RP1, Taxi . . . . .	6	1	1673 649	1673 649			
	RP1, except Taxi, RW1 w/225 cu. in. Engine . . . . .	6	1	1674 677	1674 677			
	RC1, RC2 . . . . .	8	1	----	*1552 141	*1552 141	*1552 141	
	RC3, RC4, RY1 . . . . .	8	1	----	----	----	1551 077	1551 077
	w/Heavy Duty Alternator . . . . .	6	1	2129 913	2121 221			
	RC1, RC2 . . . . .	8	1	----	2129 357	2121 221	2121 221	
	w/Dual Belt Heavy Duty Alternator RP2, High Performance, RC1, RC2 . . . . .	8	1	----	2202 390			
	Engine to Steering Pump . . . . .	8	1	----	2121 250	2121 250	2121 250	
		6	1	*1821 684	1327 471			
		8	1	----	1854 895			
	RP2, High Performance . . . . .	8	1	----	2129 277	2129 277	2129 277	2129 277
	w/Air Conditioning Engine to Fan to Steering Pump . . . . .	6	1	2202 876	2202 876			
	Engine to Compressor . . . . .	6	1	2264 364	2264 364			
	Compressor to Alternator . . . . .	6	1	1551 005	1551 005			
	Engine to Fan . . . . .	8	1	*1821 684				
	RP2, High Performance . . . . .	8	1	----	1558 058	1558 058	1558 058	1558 058
	w/Model F Air Conditioning . . . . .	8	1	*1821 684				
	RP2 High Performance . . . . .	8	1	----	1327 471	1327 471	1327 471	1327 471
	Engine to Compressor to Jackshaft . . . . .	8	1	----	1944 881			
	Jackshaft to Alternator . . . . .	8	1	----	1946 922			
	w/Model F Air Conditioning . . . . .	8	1	1551 005	1946 921			
		8	1	----	1946 921			
	RP2 High Performance . . . . .	8	1	----	1946 926	1946 926	1946 926	1946 926
	Engine to Alternator to Compressor, RP2, High Performance, RC1, RC2 . . . . .	8	1	----	1947 132	1947 132	1947 132	
	RC3, RC4, RY1 . . . . .	8	1	----	----	----	2129 284	2129 284
	w/Model F Air Conditioning . . . . .	6	1	1735 088	1735 088			
	RC3, RY1 . . . . .	8	1	----	1947 132	----	1947 132	1947 132
	RP2 High Performance, RC1, RC2 . . . . .	8	1	----	1944 881	1944 881	1944 881	
<b>7-04-0 FAN BELT IDLER PULLEY</b>								
7-04-1	PULLEY . . . . .	8	1	----	2240 397	2240 397	2240 397	2240 397
7-04-5	BRACKET, RP2 . . . . .	8	1	----	2129 666			
	RP2, High Performance . . . . .	8	1	----	2129 667	2129 667	2129 667	2129 667
	w/Model F Air Conditioning . . . . .	8	1	----	1748 275			
7-04-10	SPACER, Bracket, RP2, High Performance . . . . .	8	1	----	1851 608	1851 608	1851 608	1851 608

★ Indicates use as required.

Numerals in parentheses ( ) refer to notes.

Printed in U.S.A.

⊠ Indicates parts not listed in any previous parts book.

Prices and specifications subject to change without notice.

\* Indicates change or addition.

# 1961 PASSENGER CAR PARTS CATALOG

COOLING

CODE	PART NAME AND DESCRIPTION	CYL.	PER CAR	VALIANT	PLYMOUTH	DESOTO	CHRYSLER	IMPERIAL
<b>7-05-0 FAN PULLEY HUB</b>								
7-05-1	HUB . . . . .		1	1634 288	1634 288	1634 288	1634 288	1634 288
<b>7-06-0 FAN DRIVE AND DRIVEN PULLEYS</b>								
7-06-1	PULLEY, Drive, w/Power Strg.	6	1	2202 794				
		6	1	-----	2205 518			
	w/Dual Belt . . . . .	6	1	E2264 449	E2264 449			
	w/Std. Trans., w/o Power Strg.	8	1	-----	1821 411			
	w/Power Strg. . . . .	8	1	-----	1855 152			
	w/Auto. Trans., w/o Power Strg.	8	1	-----	1859 671			
	w/Power Strg. . . . .	8	1	-----	1859 680			
	w/Air Conditioning . . . . .	8	1	-----	1859 580			
	w/Dual Belt and Alternator . . .	8	1	-----	1852 606	1852 606		
	w/o Power Strg., RP2, High Performance, RC1, RC2 . . . . .	8	1	-----	1821 449	1821 449	1821 449	
	w/Power Strg., RP2, High Performance . . . . .	8	1	-----	1826 053	1826 053	1826 053	1826 053
	w/Air Conditioning, RP2, High Performance, RC1, RC2 . . . . .	8	1	-----	1859 252	1859 252	1859 252	
	RC3, RC4, RY1 . . . . .	8	1	-----	-----	-----	2128 545	2128 545
	w/Model F Air Conditioning . . .	6	1	2202 794	2202 794			
		8	1	-----	1859 580			
	RP2 High Performance . . . . .	8	1	-----	1859 252	1859 252	1859 252	1859 252
7-06-3	HUB, Fan Drive Pulley, w/Air Conditioning . . . . .	8	1	-----	1733 805			
7-06-5	SPACER, Fan Drive Pulley, w/Dual Belt and Alternator . .	8	1	-----	1858 488	1858 488		
7-06-14	PULLEY, Fan Driven . . . . .	6	1	2202 666	2202 666			
	w/Dual Belt . . . . .	6	1	E2264 450	E2264 450			
		8	1	-----	1852 582			
	w/o Air Conditioning, RP2, High Performance . . . . .	8	1	-----	1821 452	1821 452	1821 452	1821 452
	w/Air Conditioning, RP2, High Performance . . . . .	8	1	-----	2121 016	2121 016	2121 016	2121 016
	w/Dual Belt Alternator Drive . .	8	1	-----	1855 239	1855 239		
	w/Model F Air Conditioning, RP2 High Performance . . . . .	8	1	-----	1981 854	1981 854	1981 854	1981 854
<b>7-07-0 FAN FLUID DRIVE UNIT</b>								
7-07-1	UNIT, Fan Fluid Drive w/Air Conditioning, RP2, High Performance, RC1, RC2 . . . . .	8	1	-----	2121 724	2121 724	2121 724	
	RC3, RC4, RY1 . . . . .	8	1	-----	-----	-----	2203 024	2203 024
<b>7-08-0 RADIATOR FAN SHROUD</b>								
7-08-2	SHROUD, w/Air Conditioning . .	6	1	E2275 591				
	Upper, RC1, RC2 . . . . .	8	1	-----	1902 720	1902 720	1902 720	
	RC3, RC4, RY1 . . . . .	8	1	-----	-----	-----	1686 412	1686 412
	Lower, RC1, RC2 . . . . .	8	1	-----	1903 600	1903 600	1903 600	
	RC3, RC4, RY1 . . . . .	8	1	-----	-----	-----	1686 414	1686 414
7-08-7	BUMPER, Fan Shroud, RC3, RC4, RY1 . . . . .	8	4	-----	-----	-----	1624 506	1624 506
7-08-13	BRACKET, Fan Shroud, Right, RC3, RC4, RY1 . . . . .	8	1	-----	-----	-----	1686 451	1686 451
	Left, RC3, RC4, RY1 . . . . .	8	1	-----	-----	-----	1686 453	1686 453
7-08-15	STUD, Fan Shroud, RC1, RC2 . .	8	1	-----	1641 903	1641 903	1641 903	
7-08-16	NUT, Fan Shroud Bracket, RC3, RC4, RY1 . . . . .	8	4	-----	-----	-----	6010 006	6010 006
<b>7-11-0 RADIATOR CORE</b>								
7-11-3	CORE, Standard . . . . .	6	1	2195 555				
	High Altitude . . . . .	6	1	2195 552				
	RP1, Standard . . . . .	6	1	-----	1904 789			
	High Altitude . . . . .	6	1	-----	1904 790			
	RP2, Standard . . . . .	8	1	-----	1904 801			

\* Indicates use as required.

Numerals in parentheses ( ) refer to notes.

Printed in U.S.A.

E Indicates parts not listed in any previous parts book. May 31, 1961 Supersedes Jan. 6, 1961.

Prices and specifications subject to change without notice.

\* Indicates change or addition.

CODE	PART NAME AND DESCRIPTION	C Y L.	PER CAR	VALIANT	PLYMOUTH	DESOTO	CHRYSLER	IMPERIAL
<b>7-11-0 RADIATOR CORE - Cont'd</b>								
7-11-3	CORE - Cont'd							
	High Altitude . . . . .	8	1	----	1904 795			
	w/Air Conditioning . . . . .	8	1	----	1904 795			
	RP2, High Performance, RC1, RC2, Standard . . . . .	8	1	----	1904 807	1904 807	1904 807	
	High Altitude . . . . .	8	1	----	1904 798	1904 798	1904 798	
	w/Air Conditioning . . . . .	8	1	----	1904 799	1904 799	1904 799	
	RC3, RC4, RY1, Standard . . . . .	8	1	----	-----	-----	1904 809	*2099 908
	w/Air Conditioning . . . . .	8	1	----	-----	-----	1904 811	1904 811
	High Altitude . . . . .	8	1	----	-----	-----	1904 810	1904 810
7-11-4	SCREW, to Yoke . . . . .		4	6022 332	6022 308	6022 308	6022 308	6022 308
<b>7-12-0 RADIATOR FILLER CAP</b>								
7-12-1	CAP . . . . .		1	1686 107	1686 107	1686 107	1686 107	1686 107
<b>7-13-0 RADIATOR DRAIN COCK</b>								
7-13-2	DRAIN COCK, RC1, RC2 . . . . .		1	1686 198	1686 198	1686 198	1686 198	
	RC3, RC4, RY1 . . . . .	8	1	----	-----	-----	103 647	103 647
<b>7-14-0 RADIATOR HOSE</b>								
7-14-4	HOSE, Inlet, Upper, RV1 . . . . .	6	1	*1881 812				
	RV1 w/Air Conditioning . . . . .	6	1	1881 806				
	RP1 except Taxi . . . . .	6	1	----	1881 804			
	RP1, Taxi . . . . .	6	1	----	1881 813			
		3	1	----	1881 805			
	RP2, High Performance, w/o Air Conditioning . . . . .	8	1	----	1881 804	1881 804	1881 804	1881 804
	w/Air Conditioning . . . . .	8	1	----	1881 806	1881 806	1881 806	1881 806
7-14-5	HOSE, Outlet, Lower, use with Retainer . . . . .	6	1	*2202 869				
	Use Without Retainer . . . . .	6	1	2264 403				
	w/225 cu. in. Engine . . . . .	6	1	⊠2214 615	2202 860			
		8	1	----	1881 805			
	RP2, High Performance, RC1, RC2 . . . . .	8	1	----	2196 934	2196 934	2196 934	
	RC3, RC4, RY1, w/o Air Conditioning . . . . .	8	1	----	-----	-----	1881 809	1881 809
	RC3, RC4, RY1, w/Air Conditioning . . . . .	8	1	----	-----	-----	1881 805	1881 805
7-14-9	HOSE, Water Pump By-Pass (50 foot roll) . . . . .	6	★	1315 466	1315 466			
		8	1	----	1730 366			
7-14-10	CLAMP PACKAGE, Radiator Hose, Small . . . . .		★	1450 499	1450 499	1450 499	1450 499	1450 499
	Large . . . . .		★	1450 500	1450 500	1450 500	1450 500	1450 500
7-14-14	RETAINER, Outlet Hose . . . . .	6	1	2264 262	2264 262			
7-14-31	HOSE, Radiator Overflow (25 foot roll, sold by the foot)		★	1904 950	1904 950	1904 950	1904 950	1904 950
<b>7-16-0 RADIATOR GRILLE</b>								
7-16-11	GRILLE . . . . .	6	1	2195 952				
			1	----	1904 225	1904 480		
	RC1, RC2, RC3 . . . . .	8	1	----	-----	-----	*1904 367	
	RC4 . . . . .	8	1	----	-----	-----	1904 378	
	GRILLE, Right . . . . .	8	1	----	-----	-----	-----	1904 124
	Left . . . . .	8	1	----	-----	-----	-----	1904 717
	SCREEN, Grille . . . . .	8	1	----	-----	1904 489	-----	

★ Indicates use as required.

Numerals in parentheses ( ) refer to notes.

Printed in U.S.A.

⊠ Indicates parts not listed in any previous parts book.

Prices and specifications subject to change without notice.

\* Indicates change or addition.

1961 PASSENGER CAR PARTS CATALOG

COOLING

CODE	PART NAME AND DESCRIPTION	CYL.	PER CAR	VALIANT	PLYMOUTH	DESOTO	CHRYSLER	IMPERIAL
<b>7-16-0 RADIATOR GRILLE - Cont'd</b>								
7-16-12	SCREW, Center Panel to Fender Panel . . . . .	8	4	----	----	----	1903 976	
	To Radiator Grille, Center . . .	8	2	----	----	----	----	6022 206
7-16-21	WIRE, Radiator Grille Sound Deadener . . . . .	8	1	----	----	----	----	B1904 947
7-16-22	BRACE . . . . .	8	2	----	----	----	----	1904 131
7-16-36	FRAME, Grille, Upper, Right. .	6	1	2082 124				
	Upper, Left . . . . .	6	1	2082 125				
	Lower, Right, UP TO . . . . .	6	1	*2082 188(1)				
	Lower, Left, UP TO . . . . .	6	1	*2082 189(1)				
	Lower, Right, AFTER . . . . .	6	1	*2082 470(1)				
	Lower, Left, AFTER . . . . .	6	1	*2082 471(1)				
	Upper . . . . .	8	1	----	----	1904 490		
	Lower . . . . .	8	1	----	----	1904 491		
	RC1, RC2 . . . . .	8	1	----	----	----	1904 368	
	RC3 . . . . .	8	1	----	----	----	1904 616	
	RC4 . . . . .	8	1	----	----	----	1904 381	
	Upper . . . . .	8	1	----	----	----	----	1904 125
	Lower . . . . .	8	1	----	----	----	----	1904 126
	Extension, Grille Frame, Center Right . . . . .	8	1	----	----	----	1904 848	
	Left . . . . .	8	1	----	----	----	1904 852	
	MOULDING PACKAGE, Outer, Right . . . . .		1	----	2275 100			
	Outer, Left . . . . .		1	----	2275 101			
	Upper, Right . . . . .	8	1	----	----	2240 970		
	Upper, Left . . . . .	8	1	----	----	2240 971		
	Lower, Right . . . . .	8	1	----	----	2240 930		
	Lower, Left . . . . .	8	1	----	----	2240 931		
	Lower, Right . . . . .	8	1	----	----	----	----	2275 190
	Lower, Left . . . . .	8	1	----	----	----	----	2275 191
7-16-37	CLIP, Grille Moulding . . . . .	8	10	----	B6000 793 6000 866			
7-16-38	NUT, Grille Moulding . . . . .	8	★	----		*6010 098	----	*6022 162
7-16-41	BOLT, Radiator Grille Frame . .	6	★	6022 062				
7-16-44	CAP, Grille Frame, Upper . . . .	6	1	2082 183				
	Lower, UP To . . . . .	6	1	*2082 112(1)				
	Lower, AFTER . . . . .	6	1	*2082 472(1)				
	CAP, Grille Panel Lower Moulding . . . . .	8	1	----	----	----	----	2275 192
7-16-47	BAR, Vertical, No. 1, RC3 . . . .	8	1	----	----	----	1904 371	
	No. 2, Right, RC3 . . . . .	8	1	----	----	----	1904 372	
	No. 2, Left, RC3 . . . . .	8	1	----	----	----	1904 373	
	No. 3, Right, RC3 . . . . .	8	1	----	----	----	1904 374	
	No. 3, Left, RC3 . . . . .	8	1	----	----	----	1904 375	
	No. 4, Right, RC3 . . . . .	8	1	----	----	----	1904 376	
	No. 4, Left, RC3 . . . . .	8	1	----	----	----	1904 377	
	Center, w/MEDALLION, RC4 . . . .	8	1	----	----	----	1904 728	
	Center, w/o Medallion, RC4 . . .	8	1	----	----	----	B1904 379	
	BAR, Horizontal, Right, RC4 . . .	8	1	----	----	----	1904 648	
	Left, RC4 . . . . .	8	1	----	----	----	1904 649	
7-16-48	NUT, Grille Frame to Radiator Cross Bar . . . . .	8	7	----	----	----	6010 078	
	Grille Frame to Grille Panel . .	8	7	----	----	----	6010 098	
7-16-54	WASHER, Radiator Grille to Center Grille Bar, RC4 . . . . .	8	2	----	----	----	6006 480	
7-16-58	CLIP, Grille to Headlamp Base Plate . . . . .	8	2	----	----	6010 028		
7-16-61	LETTER, Name, w/BASE, "D" . . . .	8	1	----	----	2240 924		
	"E" . . . . .	8	1	----	----	2240 925		
	"S" . . . . .	8	1	----	----	2240 926		
	"O" . . . . .	8	1	----	----	2240 927		
	"T" . . . . .	8	1	----	----	2240 928		
	"O" . . . . .	8	1	----	----	2275 017		

NOTE 1: RV1, Serial No. 351900.

★ Indicates use as required. Numerals in parentheses ( ) refer to notes. Printed in U.S.A.  
 B Indicates parts not listed in any previous parts book. Prices and specifications subject to change without notice.  
 May 31, 1961 Supersedes Jan. 6, 1961. Page 7-8 \* Indicates change or addition.

CODE	PART NAME AND DESCRIPTION	CYL	PER CAR	VALIANT	PLYMOUTH	DESOTO	CHRYSLER	IMPERIAL
<b>7-16-O RADIATOR GRILLE - Cont'd</b>								
7-16-62	NUT, Radiator Grille Name Letter . . . . .	8	12	----	----	6010 226		
7-16-63	PANEL, Center . . . . .	8	1	----	----	1904 506		
	Lower . . . . .	8	1	----	----		*1904 385	1904 139
7-16-65	DOOR, Hood Lock Access . . . . .		1	----	1904 864			
7-16-66	SPRING, Access Door . . . . .		1	----	1904 627			
7-16-70	PIN, Hood Lock Access Door . . . . .		1	----	1832 135			
7-16-73	NUT, Grille Attaching . . . . .	8	★	----	----	----	----	6022 162
<b>7-17-O RADIATOR GRILLE MEDALLION OR ORNAMENT</b>								
7-17-1	ORNAMENT PACKAGE . . . . .		1	----	2275 102			
	MEDALLION, RC4 . . . . .	8	1	----	----	----	1904 384	
	ORNAMENT PACKAGE . . . . .	8	1	----	----	----	----	2275 016
	NUT . . . . .		2	----	----	----	----	9415 250
7-17-2	ORNAMENT BASE PACKAGE, RY1-L, RY1-M. . . . .	8	1	----	----	----	----	2275 188
	RY1-H . . . . .	8	1	----	----	----	----	2275 189
	NUT . . . . .		3	----	----	----	----	9415 250
<b>7-26-O RADIATOR YOKE</b>								
7-26-2	YOKE, RC1, RC2 . . . . .		1	----	1904 291	1904 291	1904 291	
	RC3, RC4, RY1 . . . . .	8	1	----	----	----	1904 392	1904 392
7-26-5	STUD, Upper Crossmember to Fender Bracket . . . . .	6	2	1863 586				
	To Frame . . . . .		2	----	1863 760	1863 760	1863 760	1863 760
	To Shear Panel . . . . .	6	4	----	----	----	----	6022 854
	SCREW, to Fender Side Shield . . . . .		★	----	6022 562	6022 562	6022 562	6022 562
	To Hood Lower Lock . . . . .	6	2	6022 525				
7-26-8	WASHER . . . . .	8	8	----	----	----	----	6022 192
	To Frame . . . . .		2	----	6022 193	6022 193	6022 193	6022 193
7-26-9	SEAL, to Radiator Core, w/Air Conditioning . . . . .	8	★	----	1242 974			
7-26-15	SHIELD, Radiator Air. . . . .	6	1	2082 039				
	Outer, Right . . . . .	6	1	2082 180				
	Outer, Left . . . . .	6	1	2082 181				
	w/Air Conditioning . . . . .	8	1	----	1903 941			
	RC3, RC4, RY1 . . . . .	8	1	----	----	----	1903 457	1903 457
7-26-17	CLIP, Air Shield. . . . .	8	★	----	6010 060	----	6010 060	6010 060
7-26-18	SHIM, to Frame . . . . .		★	----	1902 763	1902 763	1902 763	1902 763
7-26-29	NUT, Air Shield to Headlamp Housing Support . . . . .	6	4	6012 038				
7-26-30	PANEL, Radiator Yoke, Upper Side, Right . . . . .	6	1	2259 263				
	Side, Left . . . . .	6	1	2082 064				
	Side, Left . . . . .	6	1	2082 065				
7-26-32	CROSSMEMBER, Radiator Yoke, Side Panel Upper. . . . .	6	1	2259 265				
7-26-33	SCREW, Upper Panel . . . . .	6	★	2082 867				
7-26-34	SCREW, Radiator Air Shield . . . . .	6	3	2082 867				
7-26-37	BRACKET, Radiator Yoke Upper Crossmember, Right. . . . .	6	1	2259 266				
	Left . . . . .	6	1	2259 267				
	Crossmember to Fender Shield, Right . . . . .	6	1	1904 932				
	Left . . . . .	6	1	1904 933				
<b>7-31-O RADIATOR DUST SHIELD</b>								
7-31-2	SEAL, Dust Shield to Bumper . . . . .	8	1	----	----	1904 938	1904 938	
7-31-10	SHIELD, Dust . . . . .		1	----	1904 243			
	RC1, RC2 . . . . .	8	1	----	----	1904 463	1904 463	
	RC3, RC4 . . . . .	8	1	----	----	----	1904 397	
	RY1. . . . .	8	1	----	----	----	----	1904 148

★ Indicates use as required.

Numerals in parentheses ( ) refer to notes.

Printed in U.S.A.

☐ Indicates parts not listed in any previous parts book.

Prices and specifications subject to change without notice.

\* Indicates change or addition.

CODE	PART NAME AND DESCRIPTION	C Y L.	PER CAR	VALIANT	PLYMOUTH	DESOTO	CHRYSLER	IMPERIAL
<b>7-31-0 RADIATOR DUST SHIELD - Cont'd</b>								
7-31-14	NUT, Dust Shield . . . . .		2	----	6010 006			
7-31-15	SCREW, Dust Shield to Lock Support . . . . .		1	----	6022 802	6022 802	6022 802	
7-31-26	CLIP, Dust Shield Seal . . . . .		11	----	----	6000 070	6000 070	
7-31-45	SHIM, Radiator to Fender to Side Shield . . . . .		*	----	1903 036	1903 036	1903 036	1903 036
<b>7-33-0 RADIATOR CROSS BAR</b>								
7-33-1	BAR, Cross . . . . .		1	----	1904 234			
		8	1	----	----	1904 389	1904 389	
		8	1	----	----	----	----	1904 146
7-33-4	SUPPORT . . . . .		1	----	1904 609			
<b>7-35-0 RADIATOR STONE DEFLECTOR</b>								
7-35-2	DEFLECTOR, Right . . . . .	6	1	2082 036				
	Left . . . . .	6	1	2082 037				
	Center . . . . .	6	1	2082 038				
	Right . . . . .		1	----	1904 246			
	Left . . . . .		1	----	1904 247			
7-35-12	SCREW, to Radiator Grille . . .		2	----	6022 779			
	To Radiator Yoke, w/Air Cond.		2	----	6022 306			
<b>7-41-0 THERMOSTAT</b>								
7-41-4	THERMOSTAT, 160° Fahrenheit	6	1	2129 206	2129 206			
	180° Fahrenheit . . . . .	6	1	2129 205	2129 205			
	160° Fahrenheit . . . . .	8	1	----	1734 957	1734 957	1734 957	1734 957
	180° Fahrenheit . . . . .	8	1	----	1735 011	1735 011	1735 011	1735 011
<b>7-42-0 WATER PUMP</b>								
7-42-1	WATER PUMP PACKAGE. . . . .	6	1	2196 910	2196 910			
		8	1	----	1752 422			
	RP2, High Performance, w/o Air Conditioning . . . . .	8	1	----	1879 526	1879 526	1879 526	1879 526
	w/Air Conditioning . . . . .	8	1	----	1879 536	1879 536	1879 536	1879 536
7-42-4	REPAIR PACKAGE, Water Pump	6	1	*2298 907	*2298 907			
		8	1	----	*1752 435			
	RP2, High Performance, w/o Air Conditioning . . . . .	8	1	----	1843 447	1843 447	1843 447	1843 447
	w/Air Conditioning . . . . .	8	1	----	1752 622	1752 622	1752 622	1752 622
<b>7-43-0 WATER PUMP HOUSING</b>								
7-43-1	HOUSING, RP2, High Performance, w/o Air Conditioning . . . . .	8	1	----	1944 916	1944 916	1944 916	1944 916
	w/Air Conditioning . . . . .	8	1	----	2240 318	2240 318	2240 318	2240 318
7-43-5	SCREW, Water Pump Attaching .	6	4	579 719	579 719			
<b>7-44-0 WATER PUMP GASKET</b>								
7-44-3	GASKET, Body . . . . .	6	1	1947 521	1947 521			
		8	1	----	2129 013			
	RP2, High Performance . . . . .	8	1	----	1737 705	1737 705	1737 705	1737 705
7-44-4	GASKET, Intermediate Plate . .	6	1	1947 523	1947 523			
	RP2, High Performance, to Cylinder Block . . . . .	8	2	----	*1737 761	*1737 761	*1737 761	*1737 761

★ Indicates use as required.

Numerals in parentheses ( ) refer to notes.

Printed in U.S.A.

⊠ Indicates parts not listed in any previous parts book.

Prices and specifications subject to change without notice.

March 1, 1962 Supersedes May 31, 1961.

\* Indicates change or addition.

2448315  
2448326  
2585384





