

GROUP 6 - CLUTCH

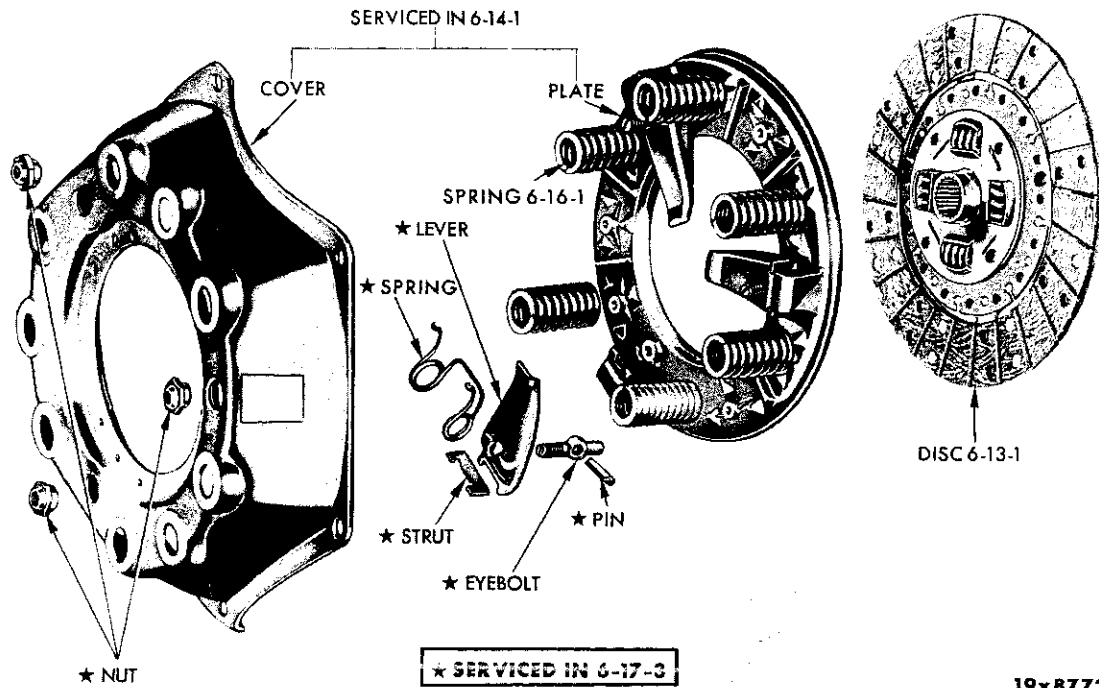

CLUTCH - VALIANT RV1

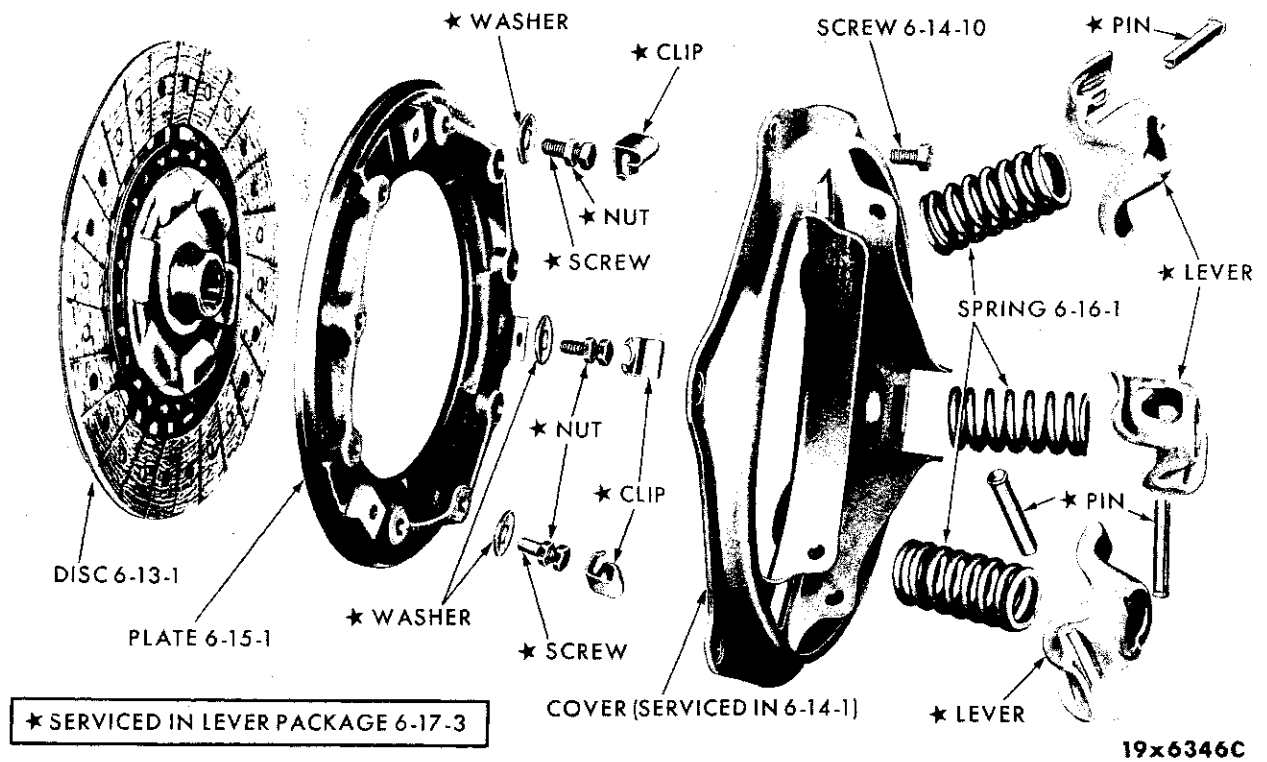

CLUTCH (TYPE 1) - EXCEPT VALIANT RV1







CODE	PART NAME AND DESCRIPTION	CYL.	PER CAR	VALIANT	PLYMOUTH	DESOTO	CHRYSLER	IMPERIAL
NOTE 1: Used with clutch having 9 pressure plate springs.								
NOTE 2: Used with clutch having 3 pressure plate springs.								
NOTE 3: Used with clutch having 6 pressure plate springs.								
NOTE 4: Used with clutch having 12 pressure plate springs.								
<b>6-01-0 CLUTCH</b>								
6-01-1	CLUTCH PACKAGE, 9 1/8" Clutch 9 1/4" Clutch, Note 1 . . . . .	6 6	1 1	2084 413 ---- --	2240 304			
<b>6-09-0 CLUTCH HOUSING</b>								
6-09-1	HOUSING, w/9 1/8", 9 1/4" and 10" Clutch . . . . .	6	1	2121 861				
	w/9 1/4" and 10" Clutch . . . . .	6	1	---- --	2121 880			
	w/318 cu. in. Eng. . . . .	8	1	---- --	2128 348			
	w/10", 10 1/2" and 11" Clutch . . . . .	8	1	---- --	2128 351	*2128 351	2128 351	
6-09-11	STRUT, to Cylinder Block, w/9 1/8", 9 1/4" Clutch . . . . .	6	1	2129 887	2129 887			
<b>6-10-0 CLUTCH HOUSING PAN</b>								
6-10-2	PAN, w/9 1/8", 9 1/4" and 10" Clutch . . . . .	6	1	2129 885	2129 885			
	w/318 cu. in. Eng. . . . .	8	1	---- --	2129 889			
	w/10 1/2" and 11" Clutch . . . . .	8	1	---- --	1739 616	1739 616	1739 616	
6-10-10	SEAL, Housing Pan, w/9 1/8", 9 1/4" and 10" Clutch . . . . .	6	1	2129 886	2129 886			
6-10-31	SCREW, includes Washer 5/16" x 13/16" . . . . .	6	5	1947 953	1947 953			
<b>6-13-0 CLUTCH DISC</b>								
6-13-1	DISC, w/10" Clutch, Note 1 . . . . .	6	1	*2200 069				
	w/9 1/8" Clutch, Note 3 . . . . .	6	1	2073 676				
	w/9 1/4" Clutch, Note 1 . . . . .	6	1	2200 068	2200 068			
	w/9 1/4" Clutch, Note 2 . . . . .	6	1	---- --	E2298 905			
	w/10" Clutch, Note 1 . . . . .	6	1	---- --	2200 069			
	w/10 1/2" Clutch, w/Eng. Stamped 61 and 83, Note 1 . . . . .	8	1	---- --	---- --	2200 055	2200 055	
	w/10" Clutch, Note 1 . . . . .	8	1	---- --	2200 051			
	w/10 1/2" Clutch, w/Eng. Stamped 18 and 13 . . . . .	8	1	---- --	2200 064			
	w/11" Clutch, Note 4 . . . . .	8	1	---- --	2200 053	2200 053	2200 053	
6-13-4	FACING, w/9 1/8" Clutch, Note 3 w/9 1/4" Clutch, Note 1 . . . . .	6 6	2 2	2073 684 859 882	859 882			
	w/9 1/4" Clutch, Note 2 . . . . .	6	2	*1820 454	1820 454			
	w/10" Clutch, Front, Note 1 . . . . .	6	1	*2201 218	*2201 218			
	w/10" Clutch, Rear, Note 1 . . . . .	6	1	*2201 217	*2201 217			
	w/10" Clutch, Note 1 . . . . .	8	2	---- --	1554 593			
	w/10 1/2" Clutch, Note 1 . . . . .	8	2	---- --	1739 092	1739 092	1739 092	
	w/11" Clutch, Note 4 . . . . .	8	2	---- --	1311 949	---- --	1311 949	
6-13-8	RIVET, Facing . . . . .		*	660 146	660 146	660 146	660 146	
6-13-19	ADJUSTER . . . . .		1	---- --	1946 360	1946 360	1946 360	
<b>6-14-0 CLUTCH COVER AND PRESSURE PLATE</b>								
6-14-1	COVER, w/PLATE, 9 1/8" Clutch, Note 3 . . . . .	6	1	2073 606				
	w/10" Clutch, Note 1 . . . . .	6	1	2201 212				
	w/9 1/4" Clutch, Note 1 . . . . .	6	1	2201 223	2201 223			
	w/9 1/4" Clutch, Note 3 . . . . .	6	1	---- --	1730 055			

★ Indicates use as required.

Numerals in parentheses ( ) refer to notes.

Printed in U.S.A.

□ Indicates parts not listed in any previous parts book.

Prices and specifications subject to change without notice.

\* Indicates change or addition.

CODE	PART NAME AND DESCRIPTION	C Y L.	PER CAR	VALIANT	PLYMOUTH	DESOTO	CHRYSLER	IMPERIAL
<b>6-14-0 CLUTCH COVER AND PRESSURE PLATE - Cont'd</b>								
6-14-1	COVER, w/PLATE - Cont'd							
	w/10" Clutch, Note 1 . . . . .	6	1	----	2200 032			
	w/10" Clutch, Note 1 . . . . .	8	1	----	2122 254			
	w/10 1/2" Clutch, Note 1 . . . . .	8	1	----	2122 255	2122 255	2122 255	
	w/11" Clutch, Note 4 . . . . .	8	1	----	2200 023	2200 023	2200 023	
6-14-4	ROLLER, Centrifugal, w/10", 10 1/2" and 11" Clutch . . . . .	8	6	----	2122 262	2122 262	2122 262	
6-14-10	SCREW, to Flywheel, 5/16" x 7/8"	6	6	307 555	307 555			
	5/16 x 7/8" . . . . .	6	6	2200 050	2200 050			
	3/8 x 1" . . . . .	8	6	314 926	314 926	314 926	314 926	
<b>6-15-0 CLUTCH PRESSURE PLATE</b>								
6-15-1	PLATE, 9 1/4" Clutch, w/9 Springs	6	1	855 519				
<b>6-16-0 CLUTCH PRESSURE SPRING</b>								
6-16-1	SPRING, 9 1/8" Clutch, 7 1/4 Red Coils . . . . .	6	3	1067 037				
	w/9 1/8" Clutch, 7 Black Coils	6	3	1321 044				
	w/10" Clutch, 7 3/4 Lavender Coils . . . . .	6	6	855 521				
	w/10" Clutch, 7 3/4 Tan Coils. .	6	3	866 591				
	w/9 1/4" Clutch, 8 1/4 Blue Coils	6	3	----	1483 287			
	w/9 1/4" Clutch, 7 3/4 Orange Coils	6	9	864 397	864 397			
	w/10" Clutch, 7 1/4 Red Coils .	6	9	----	1067 037			
	w/10 1/2" Clutch, 7 1/4 Red Coils	8	6	----	1067 037			
	w/10 1/2" Clutch, 6 3/4 White Coils	8	3	----	1406 504			
	w/11" Clutch, 7 3/4 Orange Coils	8	6	----	864 397		864 397	
	w/11" Clutch, 7 1/4 Red Coils .	8	6	1067 037	1067 037	1067 037	1067 037	
<b>6-17-0 CLUTCH RELEASE LEVER</b>								
6-17-3	PACKAGE, Lever, w/9 1/8" and 9 1/4" Clutch, Note 1 . .	6	3	1879 652	*2240 634			
	w/10", 10 1/2" and 11" Clutch. .		3	2084 250	2084 250	2084 250	2084 250	
<b>6-19-0 CLUTCH RELEASE BEARING</b>								
6-19-2	BEARING, w/SLEEVE . . . . .	6	1	2072 852	2200 027			
		8	1	2200 301	2200 301		*2200 301	
6-19-3	BEARING . . . . .		1	658 998	658 998	----	658 998	
<b>6-20-0 CLUTCH RELEASE BEARING RETURN SPRING</b>								
6-20-14	SPRING . . . . .	6	1	2073 687	2073 687			
		8	1	----	671 915	----	671 915	
<b>6-22-0 CLUTCH RELEASE FORK</b>								
6-22-1	FORK, w/SPRING . . . . .	6	1	2072 902	2072 902			
		8	1	----	1618 848	1618 848	1618 848	
6-22-4	SEAL, Release Fork . . . . .		1	----	2075 009	----	2075 009	
6-22-15	PIVOT . . . . .	6	1	2072 900	2072 900			
		8	1	----	633 238	633 238	----	633 238
6-22-17	PIN, Release Fork. . . . .		1	1324 090	1324 090	1324 090	1324 090	
6-22-19	SPRING . . . . .	6	1	2072 901	2072 901			
		8	1	----	2200 349	----	2200 349	
<b>6-24-0 CLUTCH RELEASE ROD</b>								
6-24-1	END, Front . . . . .	6	1	2072 849	2200 029			
	Front . . . . .	8	1	----	2200 029	2200 029	2200 029	
	Rear . . . . .		1	2200 028	2200 028	2200 028	2200 028	
	Rear . . . . .	6	1	1675 246				

★ Indicates use as required.

Numerals in parentheses ( ) refer to notes.

Printed in U.S.A.

⊞ Indicates parts not listed in any previous parts book.  
March 1, 1962 Supersedes May 31, 1961.

Prices and specifications subject to change without notice.

\* Indicates change or addition.

CODE	PART NAME AND DESCRIPTION	CY L.	PER CAR	VALIANT	PLYMOUTH	DESOTO	CHRYSLER	IMPERIAL
<b>6-24-0 CLUTCH RELEASE ROD - Cont'd</b>								
6-24-3	NUT, Adjusting . . . . .		1	1407 347	1407 347	1407 347	1407 347	
6-24-6	SPRING, Rear . . . . .		1	1634 508	1634 508	1634 508	1634 508	
<b>6-27-0 CLUTCH RELEASE FORK RETURN SPRING</b>								
6-27-5	SPRING, 18 Coils, 6 1/8" Lgh. . . . .	6	1	2072 855	2200 302			
	33 Coils, 6 5/16" Lgh. . . . .	8	1	-----	1820 211	1820 211	1820 211	
	33 Coils, 5 1/8" Lgh. . . . .	8	1	-----	1671 567			
<b>6-35-0 CLUTCH RELEASE CENTER SPRING</b>								
6-35-1	SPRING, RP1, RV1, RW1, w/170 cu. in. Eng. . . . .		1	*2072 894	*1820 217	*1820 217	*1820 217	
	RV1, w/225 cu. in. Eng. . . . .	6	1	*2207 738				
	RC1, w/Power Brake, UP TO Serial No. 8113-165879 . . . . .	8	1	-----	-----	-----	*1820 217	
	RC1, w/Power Brake, AFTER Serial No. 8113-165879 . . . . .	8	1	-----	-----	-----	E2260 714	
6-35-3	BRACKET . . . . .		1	-----	1730 015	1730 015	1730 015	
6-35-6	SUPPORT . . . . .		1	1946 353	1946 353	1946 353	1946 353	
6-35-8	EYE, Release Spring . . . . .	8	1	-----	-----	-----	*2200 338	
6-35-13	REINFORCEMENT . . . . .		1	-----	1731 214	1731 214	1731 214	
6-35-16	SPACER . . . . .		1	-----	2123 036	2123 036	2123 036	
6-35-17	WASHER . . . . .		1	-----	669 896	669 896	669 896	
6-35-18	BUMPER, Spring Adjuster . . . . .		1	-----	6010 155	6010 155	6010 155	
6-35-19	SPRING, Release Adjusting . . . . .	8	1	-----	-----	-----	*1946 360	
<b>6-38-0 CLUTCH PEDAL</b>								
6-38-1	PEDAL, Std. . . . .		1	*2207 752	*2073 636	*2073 636	*2073 636	
	Heavy Duty . . . . .		1	2207 757				
	w/6 in. Clutch Arm . . . . .	8	1	-----	E2200 335	E2200 335	E2200 335	
	w/5 1/2 in. Clutch Arm . . . . .	8	1	-----	E2260 717	E2260 717	E2260 717	
6-38-3	BUSHING . . . . .		1	1637 779	1637 779			
	BEARING . . . . .	8	1	*1946 377	1946 377	-----	1946 377	
6-38-4	WASHER, Shaft Lock Ring . . . . .	6	1	2073 632				
6-38-7	SEAL, Pedal Bearing . . . . .		1	1730 019	1730 019	1730 019	1730 019	
6-38-14	RING, Bearing Lock, Heavy Duty and Taxi . . . . .	6	1	2072 831				
6-38-23	STOP, Pedal . . . . .		1	1940 147	1940 147	1940 147	1940 147	
6-38-26	BRACKET, Pedal Stop . . . . .		1	2072 896	1730 007	1730 007	1730 007	
<b>6-39-0 CLUTCH PEDAL PAD</b>								
6-39-2	PAD . . . . .		1	1616 898	2201 195	-----	2201 195	
<b>6-43-0 CLUTCH PEDAL SHAFT</b>								
6-43-7	WASHER, Plain . . . . .	6	1	2073 632				
6-43-13	SEAL, Bearing, Heavy Duty and Taxi . . . . .	6	1	1730 019				
<b>6-50-0 CLUTCH PEDAL ROD</b>								
6-50-1	ROD, w/Power Brake, w/Heavy Duty Trans. . . . .		1	2073 642	1940 175	1940 175	1940 175	
6-50-6	WASHER, Rod Spring, w/Heavy Duty and w/Power Brake . . . . .		1	1614 579	1614 579	1614 579	1614 579	
6-50-10	BOOT . . . . .	6	1	2072 837	1731 232			
	w/PowerFlite Trans. . . . .	8	1	-----	2080 536			
6-50-11	SEAL . . . . .	6	1	-----	1731 234			
6-50-12	REINFORCEMENT . . . . .	6	1	2072 838	1731 233			

★ Indicates use as required.

Numerals in parentheses ( ) refer to notes.

Printed in U.S.A.

E indicates parts not listed in any previous parts book.

Prices and specifications subject to change without notice.

\* Indicates change or addition.

