

GROUP 6 - CLUTCH

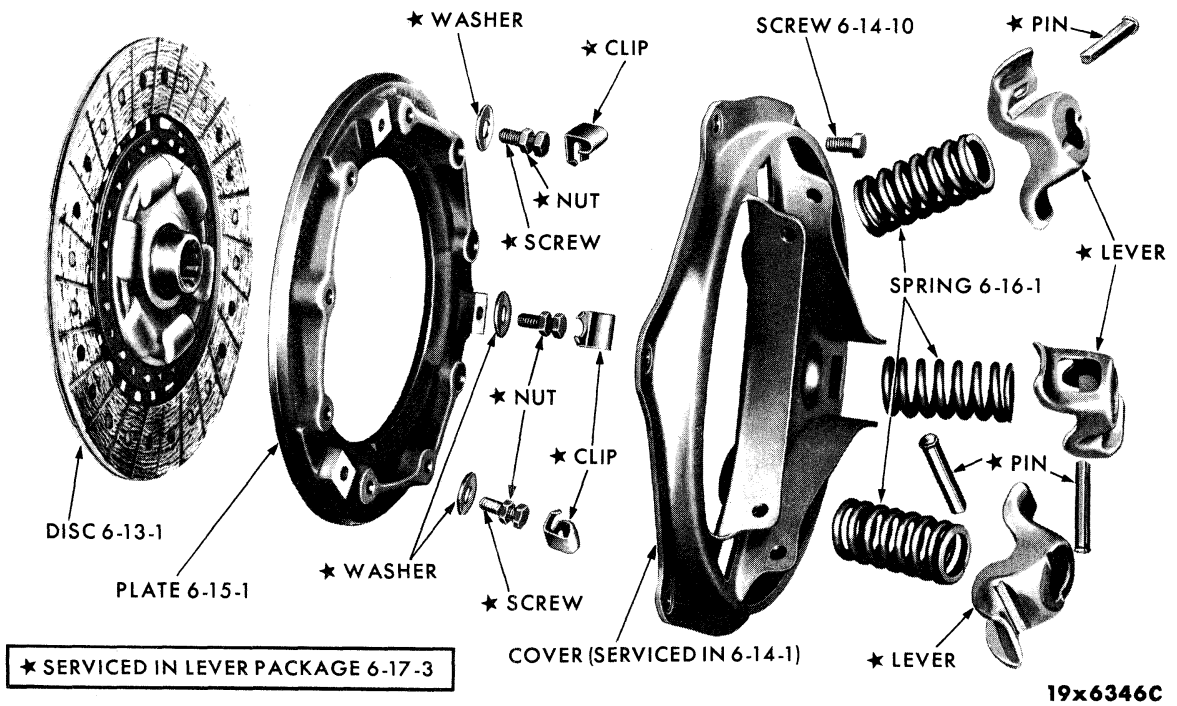

CLUTCH - TYPE 1

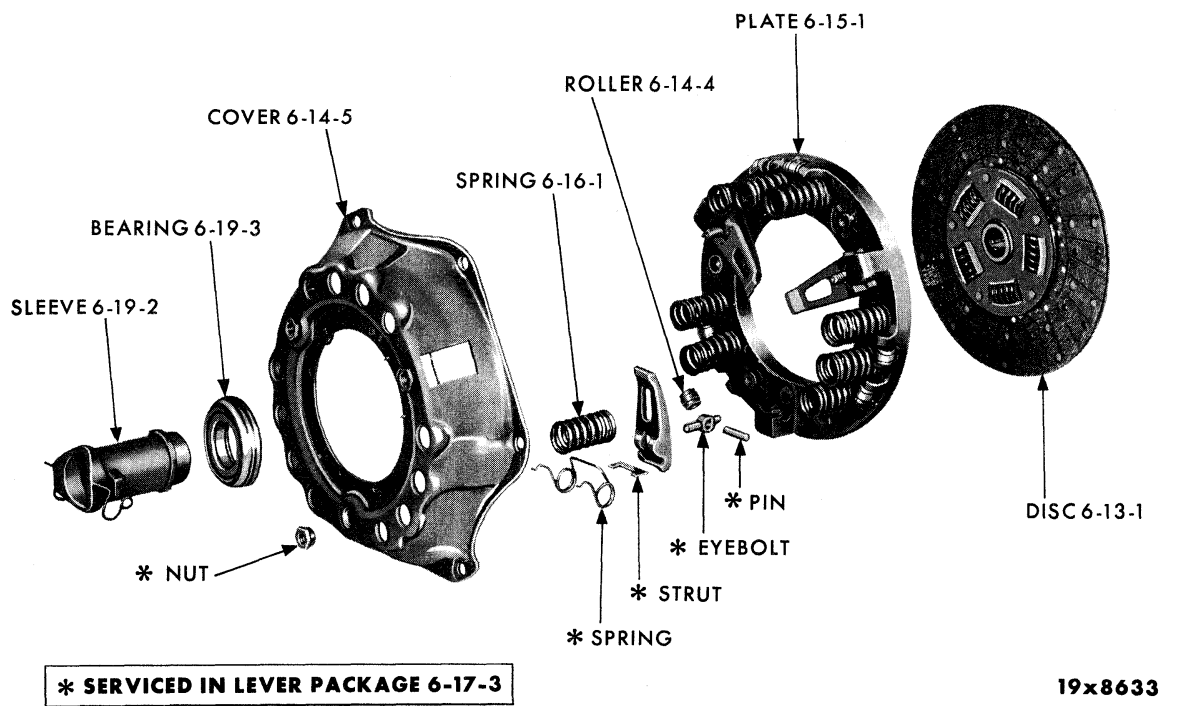

CLUTCH - TYPE 2



CODE	PART NAME AND DESCRIPTION	NO. OF CYL.	PLYMOUTH	DODGE	DESOTO	CHRYSLER AND IMPERIAL	PER CAR	PART NUMBER
------	---------------------------	-------------	----------	-------	--------	-----------------------	---------	-------------

GROUP 6 - CLUTCH

Type 1. Used with clutch having 3 pressure plate springs.  
 Type 2. Used with clutch having 6 pressure plate springs.  
 Type 3. Used with clutch having 9 pressure plate springs.

**6-01-0 CLUTCH**

6-01-3	PACKAGE, Clutch . . . . .	6	60	60	-	-	1	2196 061
--------	---------------------------	---	----	----	---	---	---	----------

**6-09-0 CLUTCH HOUSING**

6-09-1	HOUSING, w/9 1/4" and 10" Clutch . . . . .	6	60	60	-	-	1	*2121 880
	PD4, w/10" and 10 1/2" Clutch UP TO Eng. No. 261116 . . . . .	8	60	60	-	-	1	*1851 379
	PD4, w/10" and 10 1/2" Clutch AFTER Eng. No. 261116 . . . . .	8	60	-	-	-	1	Ⓔ2128 348
	PP2 High Performance, PD1 . . . . .	8	60	60	-	-	1	*1855 737
	PP2, PD1, PD2, PD4, w/11" Clutch . . . . .	8	60	60	-	-	1	2121 793
6-09-6	SCREW, Clutch Housing . . . . .	6	60	60	-	-	5	*1947 953
6-09-11	STRUT, to Cylinder Block . . . . .	6	60	60	-	-	1	Ⓔ2129 887

**6-10-0 CLUTCH HOUSING PAN**

6-10-2	PAN, w/9 1/4" and 10" Clutch . . . . .	6	60	60	-	-	1	Ⓔ2129 885
	PP2, PD4, w/10" and 10 1/2" Clutch UP TO Eng. No. 261116 . . . . .	8	60	60	-	-	1	*1638 998
	PP2, PD4, w/10" and 10 1/2" Clutch AFTER Eng. No. 261116 . . . . .	8	60	60	-	-	1	Ⓔ2129 669
	PP2 High Performance, PD1 . . . . .	8	60	60	-	-	1	1739 616
	PP2, PD1, PD2, PD4, w/11" Clutch . . . . .	8	60	60	-	-	1	2121 794
6-10-10	SEAL, Dust . . . . .	6	60	60	-	-	1	2128 421

**6-13-0 CLUTCH DISC**

6-13-1	DISC, 9 1/4" Clutch, w/Light Blue Springs . . . . .	6	60	60	-	-	1	2200 061
	10" Clutch, w/Light Blue Springs . . . . .	6	60	60	-	-	1	2200 060
	10" Clutch, Taxi . . . . .	6	60	60	-	-	1	Ⓔ2201 216
	10 1/2" Clutch, PD1 . . . . .	8	60	60	-	-	1	*2123 044
	10 1/2" Clutch, PP2, PD4, UP TO Eng. No. 260283 . . . . .	8	60	60	-	-	1	*2123 044
	10 1/2" Clutch, PD2, PD4, AFTER Eng. No. 260283 . . . . .	8	60	60	-	-	1	*2200 064
	10" Clutch, PP2, PD4, UP TO Eng. No. 261116, PD2 All . . . . .	8	60	60	-	-	1	*2123 045
	10" Clutch, PP2, PD4 AFTER Eng. No. 261116 . . . . .	8	60	60	-	-	1	*2200 051
	11" Clutch, 10 Spline . . . . .	8	60	60	-	-	1	*2200 022
6-13-4	FACING, 9 1/4" Clutch, Type 1 . . . . .	6	60	60	-	-	2	1820 454
	9 1/4" Clutch, Type 2 . . . . .	6	60	60	-	-	2	859 882
	10" Clutch, Type 3 . . . . .	6	60	60	-	-	2	* 684 364
	10" Clutch, PD4 . . . . .	8	60	60	-	-	2	1554 593
	10" Clutch, Front, Taxi . . . . .	6	60	60	-	-	1	Ⓔ2201 218
	10" Clutch, Rear, Taxi . . . . .	6	60	60	-	-	1	Ⓔ2201 217
	10 1/2" Clutch, PD1, PD4 . . . . .	6-8	60	60	-	-	2	1739 092
	11" Clutch, PD1, PD2 . . . . .	8	60	60	-	-	2	1311 949
6-13-8	RIVET, Type 1 . . . . .	6	60	60	-	-	24	1313 312
	Type 2 . . . . .	6-8	60	60	-	-	★	660 146

**6-14-0 CLUTCH COVER AND PRESSURE PLATE**

6-14-1	COVER, w/PLATE, 9 1/4" and 10" Clutch . . . . .	6	60	60	-	-	1	Ⓔ2201 223
	10" Clutch, PD4 . . . . .	8	60	60	-	-	1	2122 254
	10 1/2" Clutch, PD1, PD4 . . . . .	8	60	60	-	-	1	2122 255
	11" Clutch, PD1, PD2, PD4, PC1 . . . . .	8	60	60	-	60	1	*2200 023
6-14-4	ROLLER, Centrifugal . . . . .	8	60	60	-	-	6	2122 262
6-14-10	SCREW, to Flywheel, 9 1/4" Clutch . . . . .	6	60	60	-	-	6	307 555
	10", 10 1/2", 11" Clutch . . . . .	6	60	60	-	-	6	2200 050
	10", 10 1/2" and 11" Clutch . . . . .	6-8	60	60	-	-	6	314 926

★ Indicates use as required. Numerals in parentheses ( ) refer to notes. Printed in U.S.A.  
 Ⓔ Indicates parts not listed in any previous parts book. Prices and specifications subject to change without notice.  
 \* Indicates change or addition. Page 6-3 Dec. 9, 1960 Supersedes April 20, 1960.

# 1960 PASSENGER CAR PARTS CATALOG

CLUTCH

CODE	PART NAME AND DESCRIPTION	NO. OF CYL.	PLYMOUTH	DODGE	DESOTO	CHRYSLER AND IMPERIAL	PER CAR	PART NUMBER
<b>6-15-0 CLUTCH PRESSURE PLATE</b>								
6-15-1	PLATE, 9 1/4" Clutch, Type 2 . . . . .	6	60	60	-	-	1	855 519
<b>6-16-0 CLUTCH PRESSURE SPRING</b>								
6-16-1	SPRING, 9 1/4" Clutch, Orange . . . . .	6	60	60	-	-	★	* 864 397
	9 1/4" Clutch, Type 2, White . . . . .	6	60	60	-	-	6	1406 504
	10" Clutch . . . . .	6-8	60	60	-	-	9	*1067 037
	10 1/2" Clutch, PD1, PD4, Red . . . . .	8	60	60	-	-	9	1067 037
	11" Clutch, PD1, White . . . . .	8	-	60	-	-	6	1406 504
	11" Clutch, PD1, Tan . . . . .	8	-	60	-	-	★	864 397
<b>6-17-0 CLUTCH RELEASE LEVER</b>								
6-17-3	PACKAGE, Lever, 9 1/4" Clutch, Type 2 . . . . .	6	60	60	-	-	3	1879 652
	9 1/4" Clutch, Type 1 . . . . .	6	60	60	-	-	3	1879 655
	10", 10 1/2" and 11" Clutch . . . . .	6-8	60	60	-	-	3	2084 250
<b>6-19-0 CLUTCH RELEASE BEARING</b>								
6-19-2	BEARING, w/SLEEVE . . . . .	6	60	60	-	-	1	2200 027
	UP TO 261116 . . . . .	8	60	60	-	-	1	*1634 511
	PP2, PD4, w/A903 Trans. AFTER 261116 . . . . .	8	60	60	-	-	1	*2200 301
6-19-3	BEARING . . . . .	6-8	60	60	-	-	1	658 998
<b>6-20-0 CLUTCH RELEASE BEARING PULL-BACK SPRING</b>								
6-20-14	SPRING . . . . .	6	60	60	-	-	2	2073 687
		8	60	60	-	-	2	671 915
<b>6-22-0 CLUTCH RELEASE FORK</b>								
6-22-1	FORK, w/SPRING . . . . .	6	60	60	-	-	1	2072 902
		8	60	60	-	-	1	1618 848
6-22-4	SEAL . . . . .	6-8	60	60	-	-	1	2075 009
	PIVOT . . . . .	8	60	60	-	-	1	* 633 238
6-22-15	PIVOT . . . . .	6	60	60	-	-	1	2072 900
6-22-17	PIN . . . . .	6-8	60	60	-	-	1	1324 090
6-22-19	SPRING . . . . .	6	60	60	-	-	1	2072 901
		8	60	60	-	-	1	863 905
<b>6-24-0 CLUTCH RELEASE FORK ROD</b>								
6-24-1	END, Front. . . . .	6	60	60	-	-	1	2200 029
		8	60	60	-	-	1	1675 245
	Front, PP2 High Performance . . . . .	8	60	60	-	-	1	1820 448
	Rear . . . . .	6	60	60	-	-	1	2200 028
		8	60	60	-	-	1	1675 246
6-24-3	NUT, Adjusting . . . . .	6-8	60	60	-	-	1	1407 347
6-24-6	SPRING, Rear . . . . .	6-8	60	60	-	-	1	1634 508
<b>6-27-0 CLUTCH RELEASE FORK PULL-BACK SPRING</b>								
6-27-5	SPRING . . . . .	6	60	60	-	-	1	2200 302
		8	60	60	-	-	1	1820 211

★ Indicates use as required. Numerals in parentheses ( ) refer to notes. Printed in U.S.A.  
 ☐ Indicates parts not listed in any previous parts book. Prices and specifications subject to change without notice.  
 Dec. 9, 1960 Supersedes April 20, 1960. Page 6-4 \* Indicates change or addition.

CODE	PART NAME AND DESCRIPTION	NO. OF CYL.	PLYMOUTH	DODGE	DESOTO	CHRYSLER AND IMPERIAL	PER CAR	PART NUMBER
<b>6-35-0 CLUTCH RELEASE OVERCENTER SPRING</b>								
6-35-1	SPRING . . . . .	6-8	60	60	-	60	1	1820 217
6-35-3	BRACKET, PC1 . . . . .	6-8	60	60	-	-	1	1730 015
6-35-6	SUPPORT . . . . .	6-8	60	60	-	-	1	1946 353
6-35-8	EYE . . . . .	6-8	60	60	-	-	1	1610 954
6-35-12	NUT . . . . .	6-8	60	60	-	-	1	1730 014
6-35-13	REINFORCEMENT . . . . .	6-8	60	60	-	-	1	1731 214
6-35-16	SPACER . . . . .	6-8	60	60	-	-	1	2123 036
6-35-17	WASHER . . . . .	6-8	60	60	-	-	1	669 896
6-35-18	BUMPER, Spring Adjuster . . . . .	6-8	60	60	-	-	1	6010 155
6-35-19	ADJUSTER . . . . .	6-8	60	60	-	-	1	1946 360
<b>6-38-0 CLUTCH PEDAL</b>								
6-38-1	PEDAL, 9 1/4" Clutch . . . . .	6	60	60	-	-	1	2200 334
	Except 9 1/4" Clutch . . . . .	6-8	60	60	-	-	1	2200 335
6-38-3	BUSHING, 9 1/4" Clutch . . . . .	6	60	60	-	-	2	1637 779
	Bearing, 10" and 11" Clutch . . . . .	6-8	60	60	-	-	2	1946 377
6-38-7	SEAL . . . . .	6-8	60	60	-	-	2	1730 019
6-38-23	STOP, Pedal . . . . .	6-8	60	60	-	-	1	1940 147
6-38-26	BRACKET, Stop . . . . .	6-8	60	60	-	-	1	1730 007
<b>6-39-0 CLUTCH PEDAL PAD</b>								
6-39-2	PAD . . . . .	6-8	60	60	-	-	1	2201 195
<b>6-50-0 CLUTCH PEDAL ROD</b>								
6-50-1	ROD . . . . .	6-8	60	60	-	-	1	1940 175
6-50-6	WASHER, Spring . . . . .	6-8	60	60	-	-	2	1614 579
6-50-10	BOOT, Rod . . . . .	6-8	60	60	-	-	1	1731 232
6-50-11	SEAL, Boot . . . . .	6-8	60	60	-	-	1	1731 234
6-50-12	REINFORCEMENT, Boot . . . . .	6-8	60	60	-	-	1	1731 233
<b>6-52-0 CLUTCH TORQUE SHAFT</b>								
6-52-1	SHAFT, 9 1/4" Clutch . . . . .	6	60	60	-	-	1	1946 393
	Except 9 1/4" Clutch . . . . .	6-8	60	60	-	-	1	1940 182
	PP2 High Performance . . . . .	8	60	60	-	-	1	1940 184
6-52-10	STUD, Engine, PD4, 3" lgh. . . . .	6-8	60	60	-	-	1	1829 377
	Engine, 2" lgh. . . . .	8	60	60	-	-	1	1829 383
	BRACKET, w/STUD . . . . .	6-8	60	60	-	-	1	1675 242
6-52-11	BEARING, Pivot . . . . .	6-8	60	60	-	-	4	635 884
6-52-12	SNAP RING . . . . .	6-8	60	60	-	-	1	1140 557
6-52-15	WASHER, Pin . . . . .	6-8	60	60	-	-	2	1614 579

## NOTES

★ Indicates use as required.

Numerals in parentheses ( ) refer to notes.

Printed in U.S.A.

☐ Indicates parts not listed in any previous parts book.

Prices and specifications subject to change without notice.

\* Indicates change or addition.

