

GROUP 23 - BODY

INSTRUCTIONS

FOR

ORDERING TRIM MATERIAL

The following pages contain line drawings of basic interior body trim sketches for use in ordering trim material. These drawings represent the various body styles and should be used in selecting the proper sketch for ordering material.

By placing a piece of tracing paper (or any piece of transparent paper) over the drawing which applies to the body style, it can be easily traced for the section for which the trim is being ordered. The particular design which varies in different vehicles can be drawn in to show the pattern and design. Then label each section with "A", "B", "C", etc. on the sketch and include a small piece of material also labeled to correspond to the sketch - see sample below.

Always furnish vehicle serial number. Also specify "right" or "left" when ordering material requiring this description.

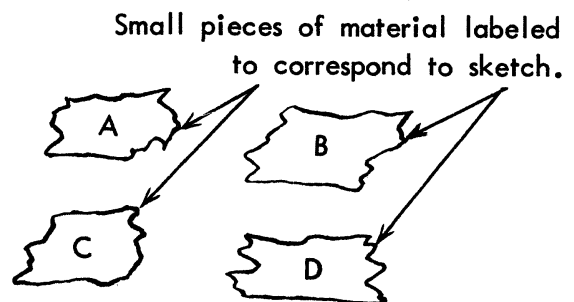
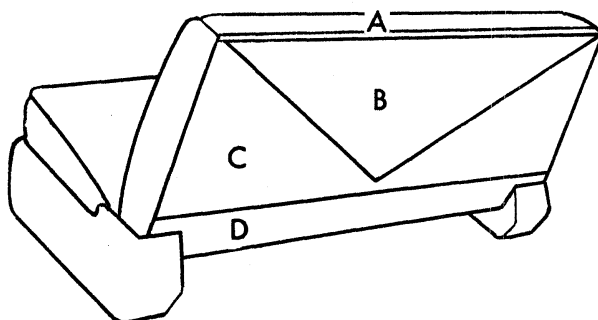

19x6975

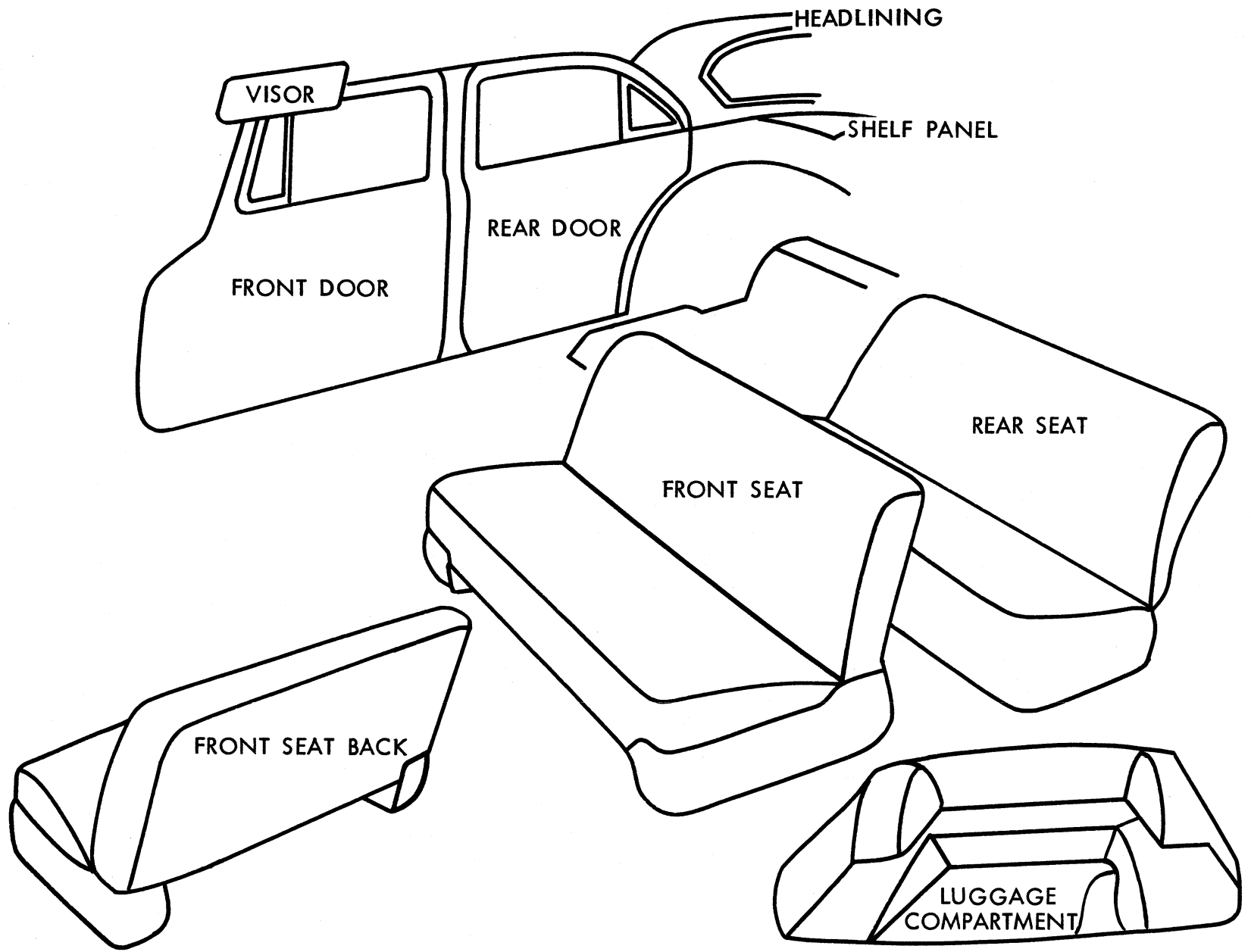

4 DOOR SEDAN AND SPECIAL 4 DOOR SEDAN

19x6960

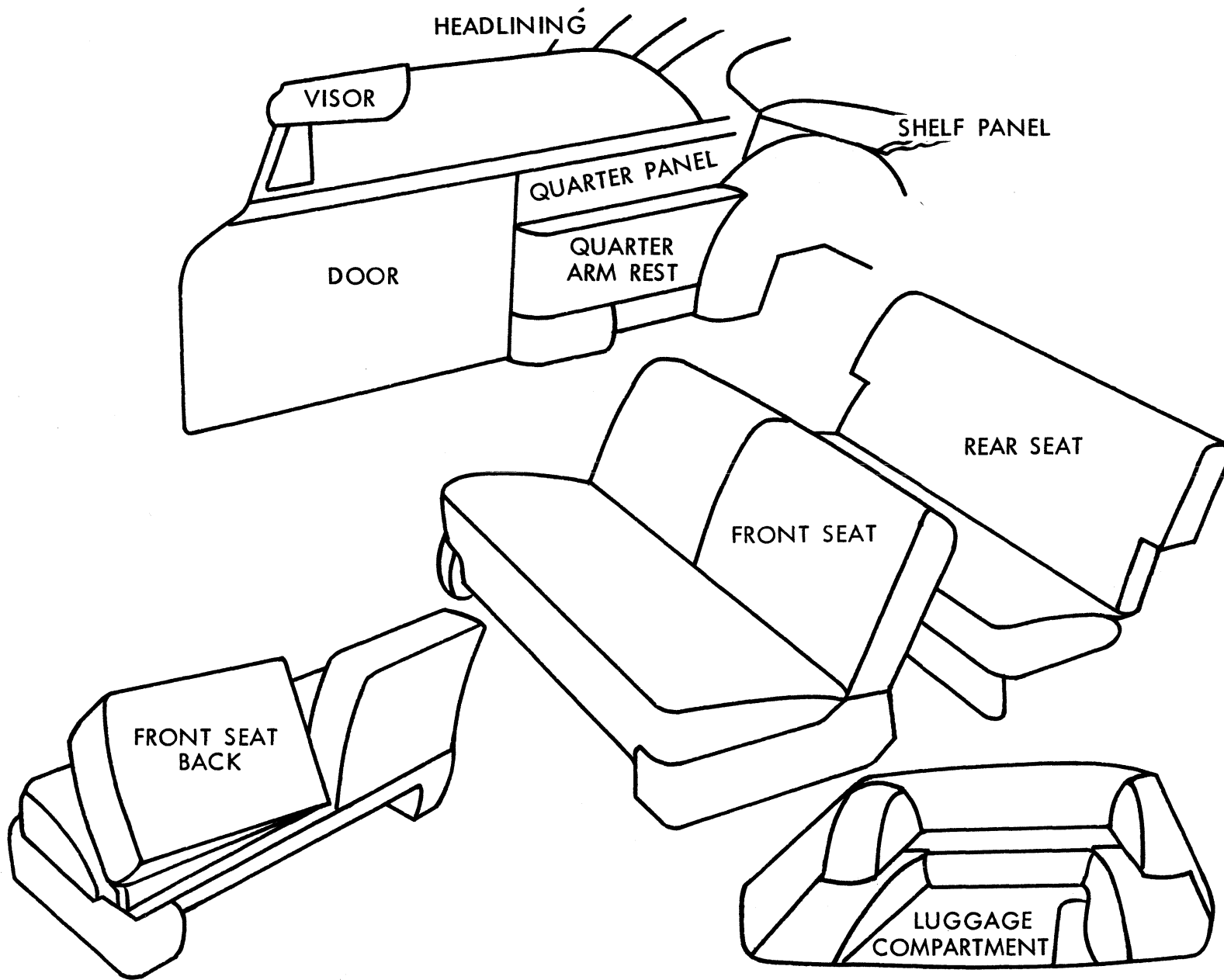

SPECIAL CLUB COUPE

19x6962

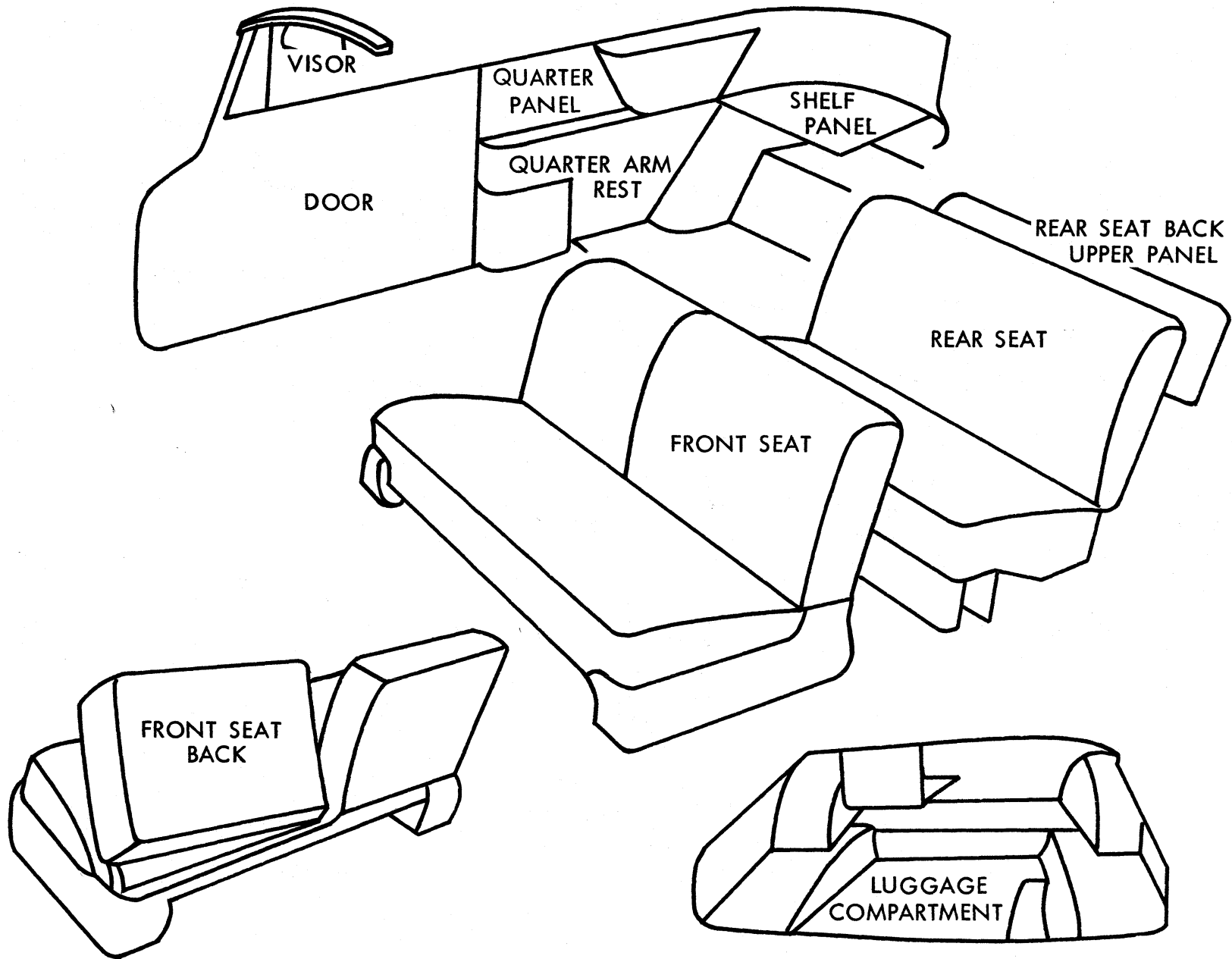

CONVERTIBLE COUPE

19x6963

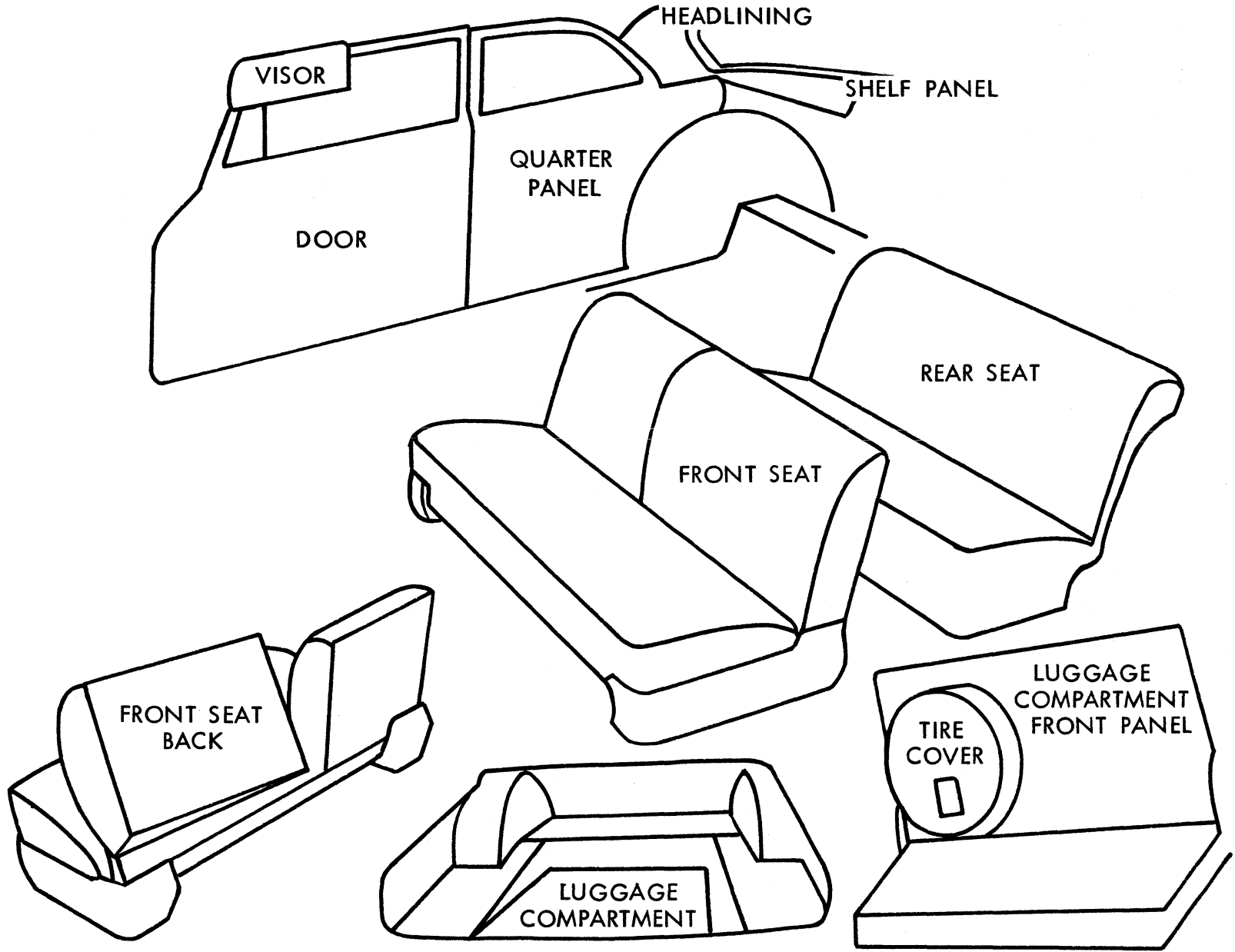

CLUB SEDAN AND 3 PASSENGER COUPE

19x6961A

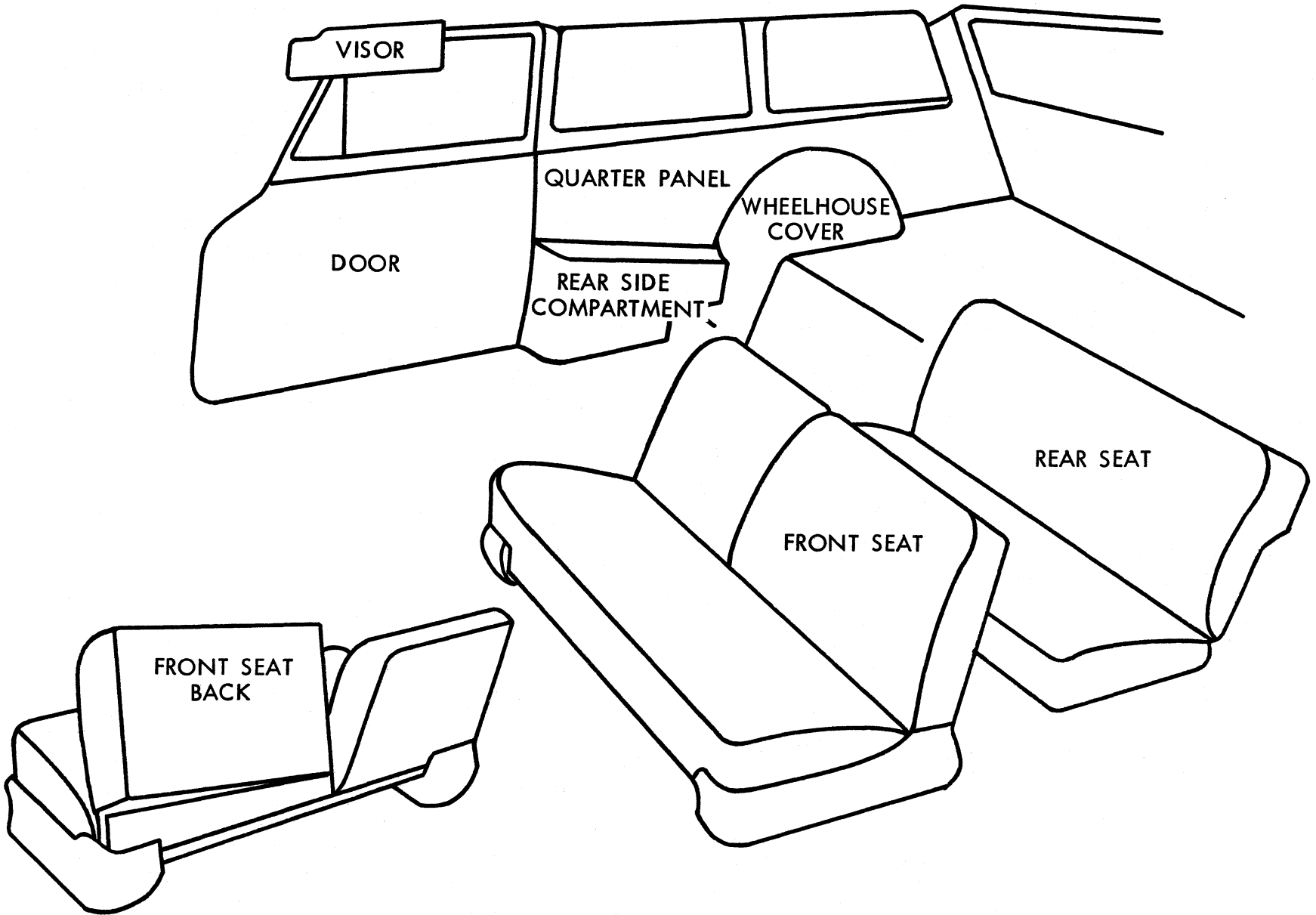

2 DOOR SUBURBAN

19x6964

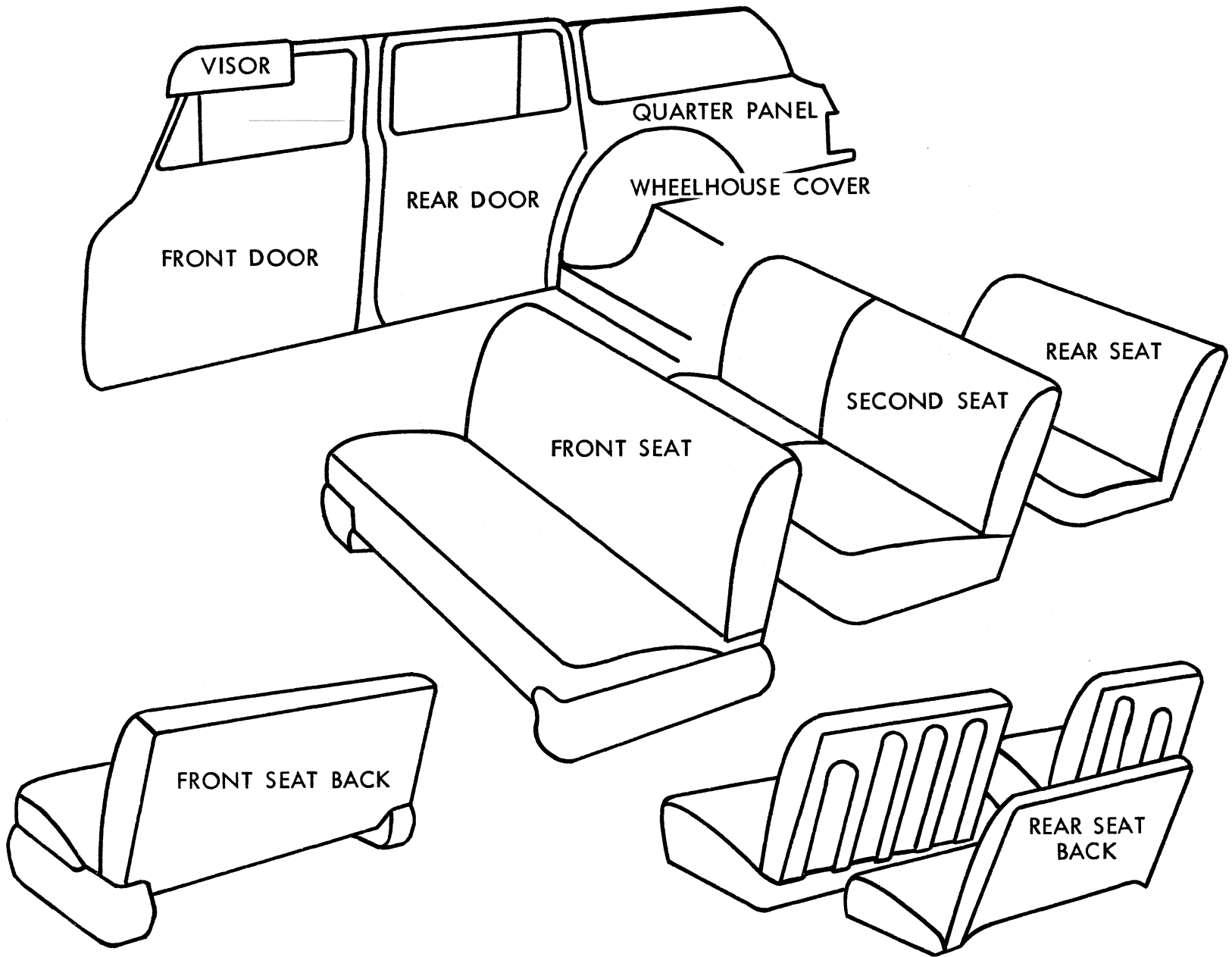

4 DOOR SUBURBAN

19x6965

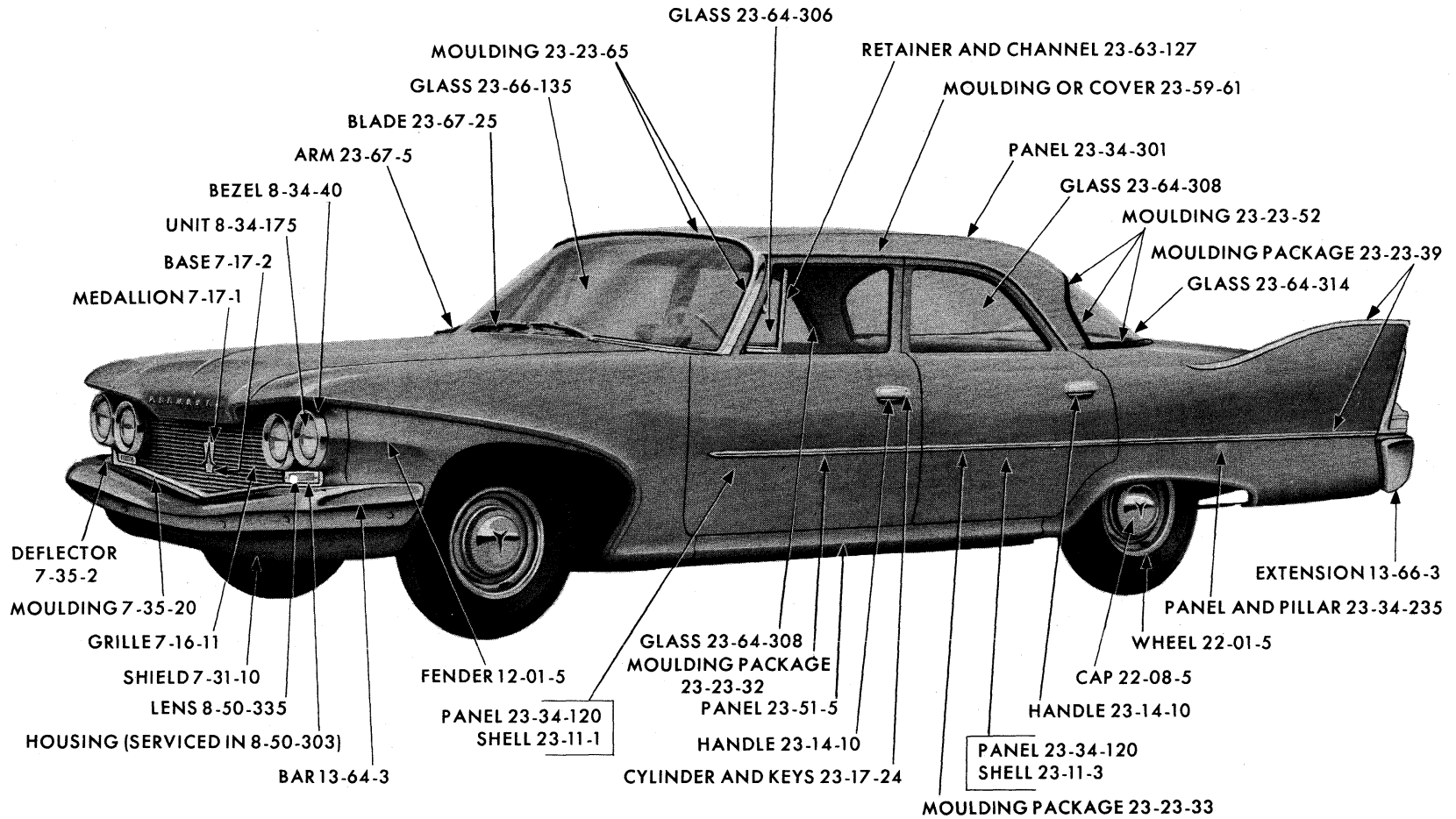

19x8647A

FRONT EXTERIOR - PLYMOUTH PP1-2 4 DOOR SEDAN

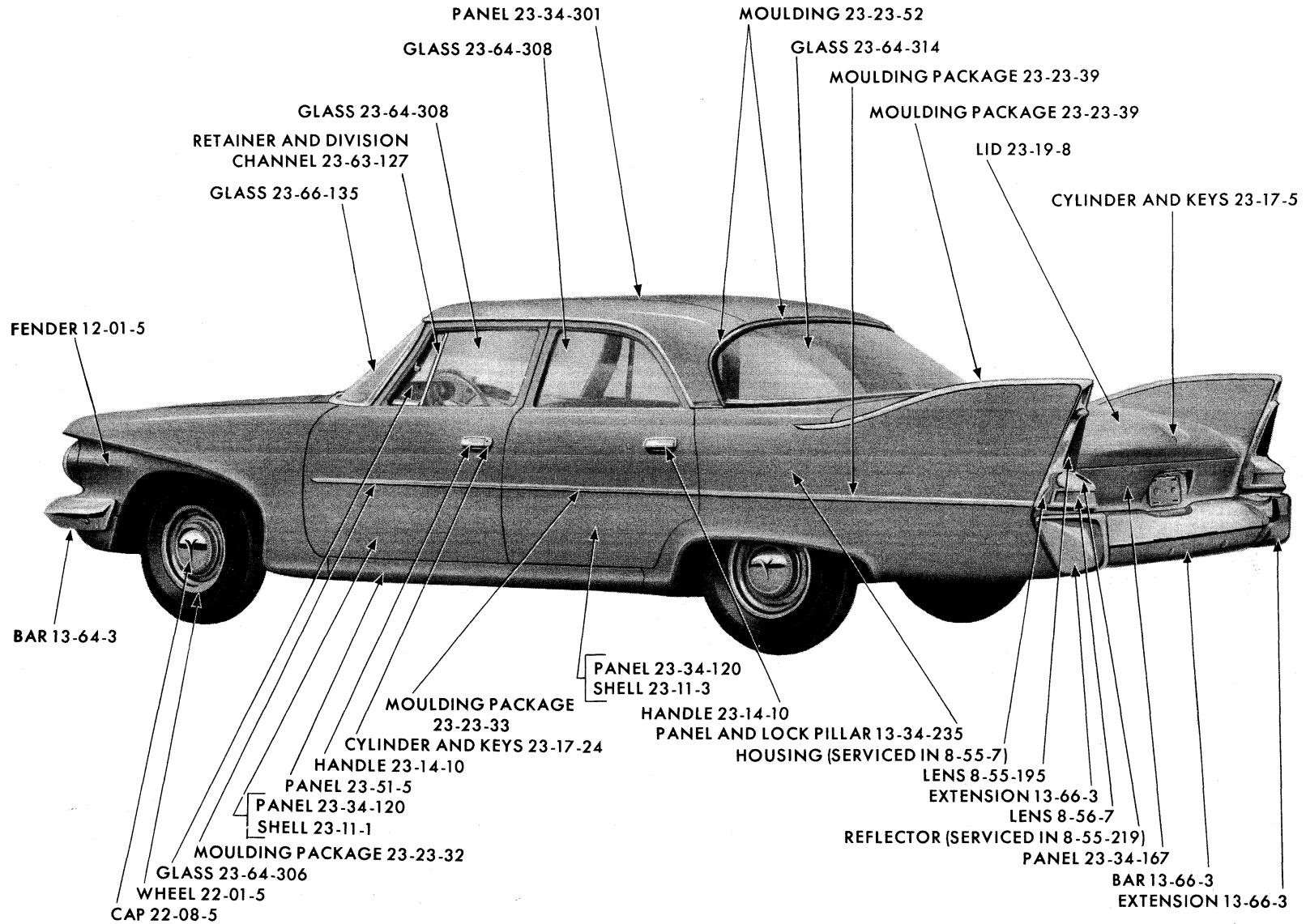

19x8648A

REAR EXTERIOR - PLYMOUTH PP1-2 4 DOOR SEDAN

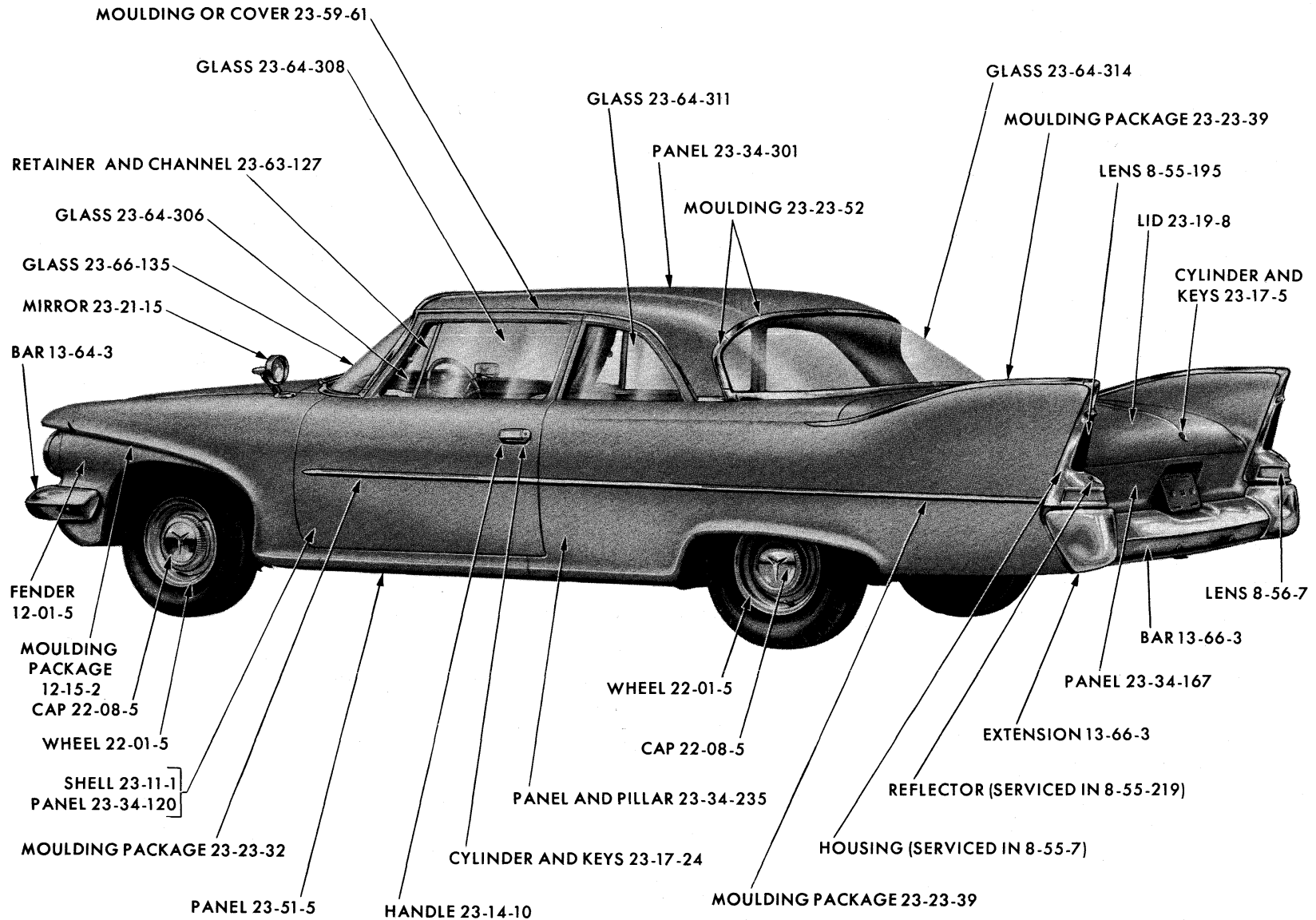

19x8698A

REAR EXTERIOR - PLYMOUTH PP1-2 CLUB SEDAN

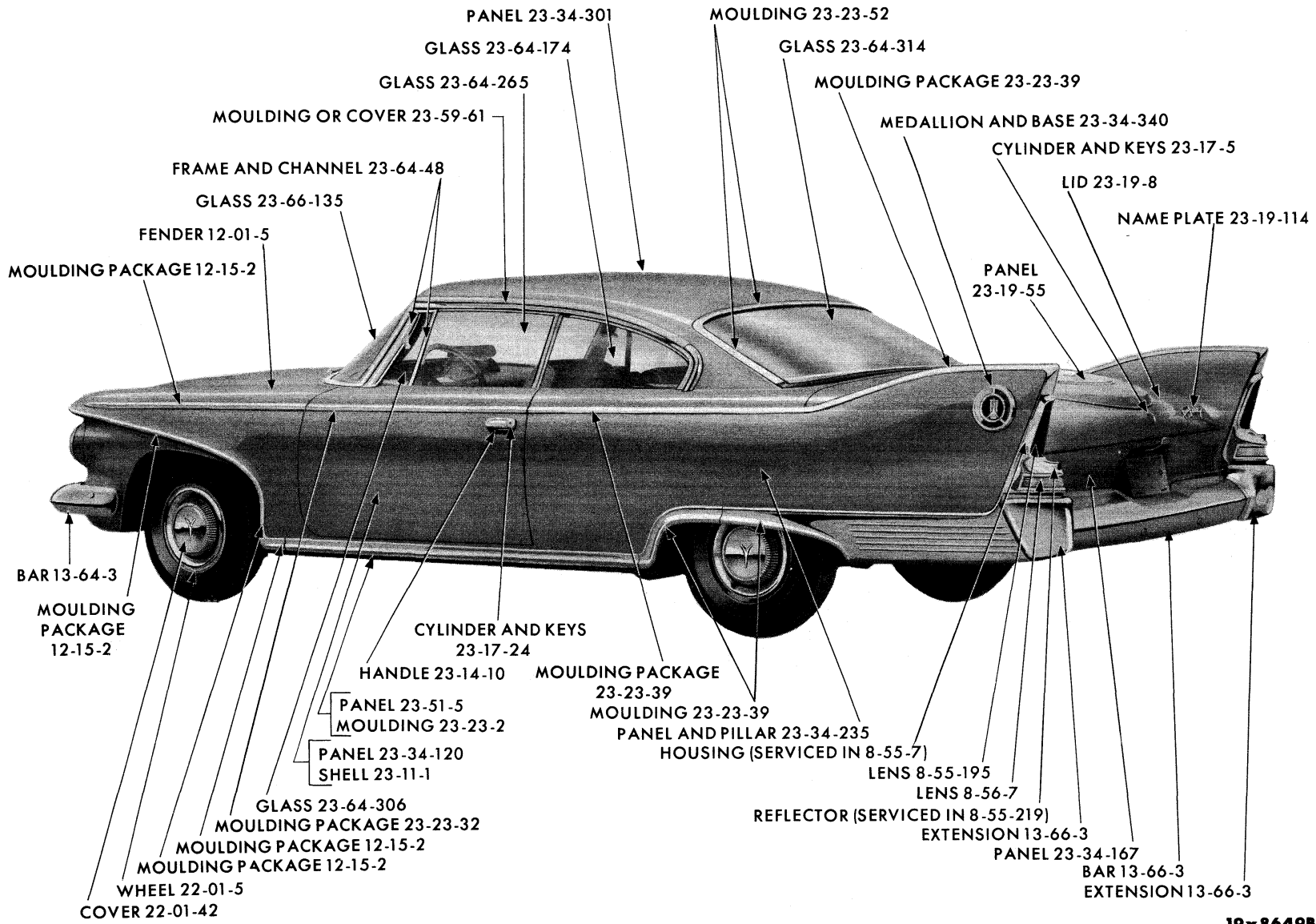

19x8649B

REAR EXTERIOR - PLYMOUTH PP1-2 SPECIAL CLUB COUPE

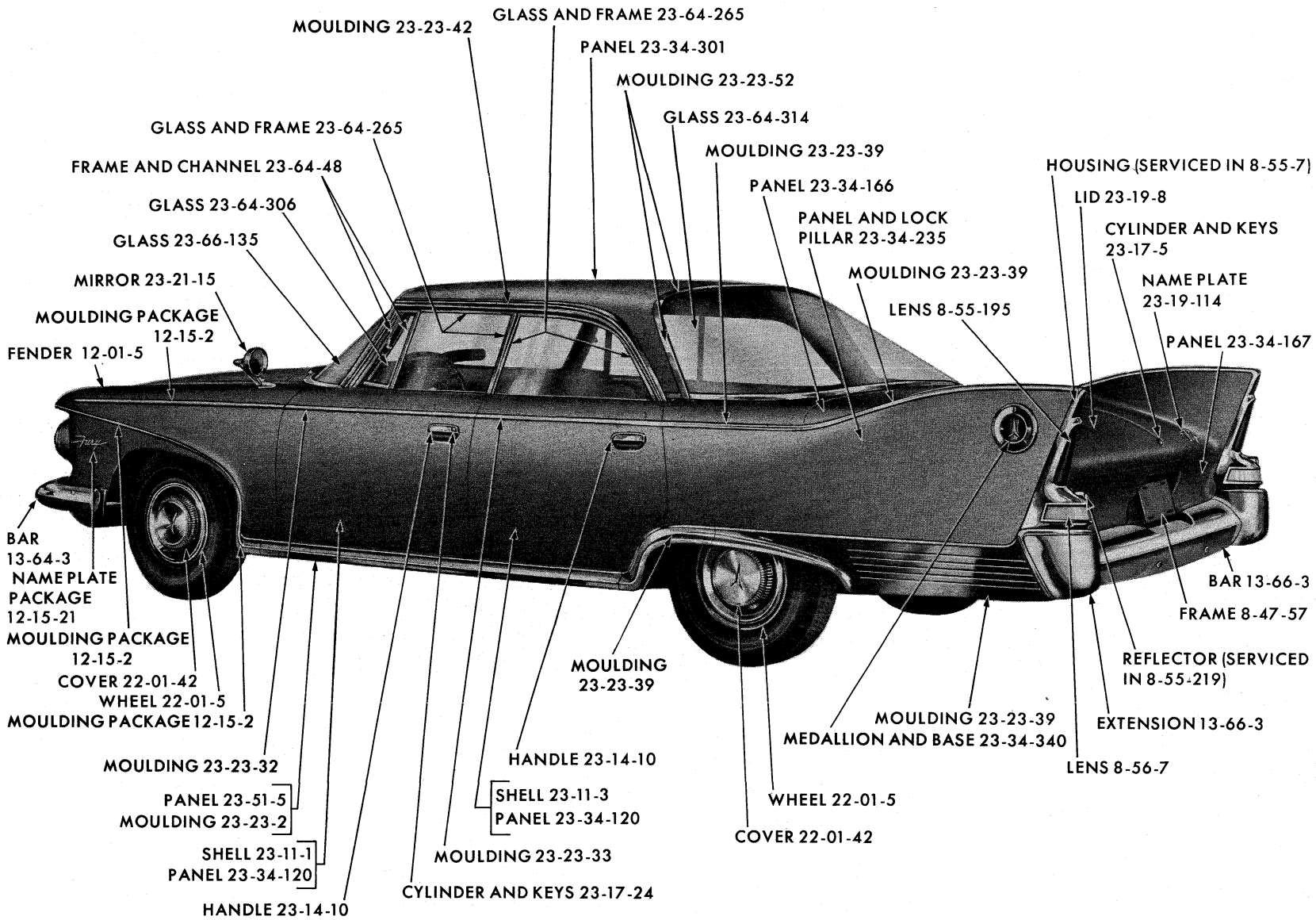

19x8632B

REAR EXTERIOR - PLYMOUTH PP1-2 SPECIAL 4 DOOR SEDAN

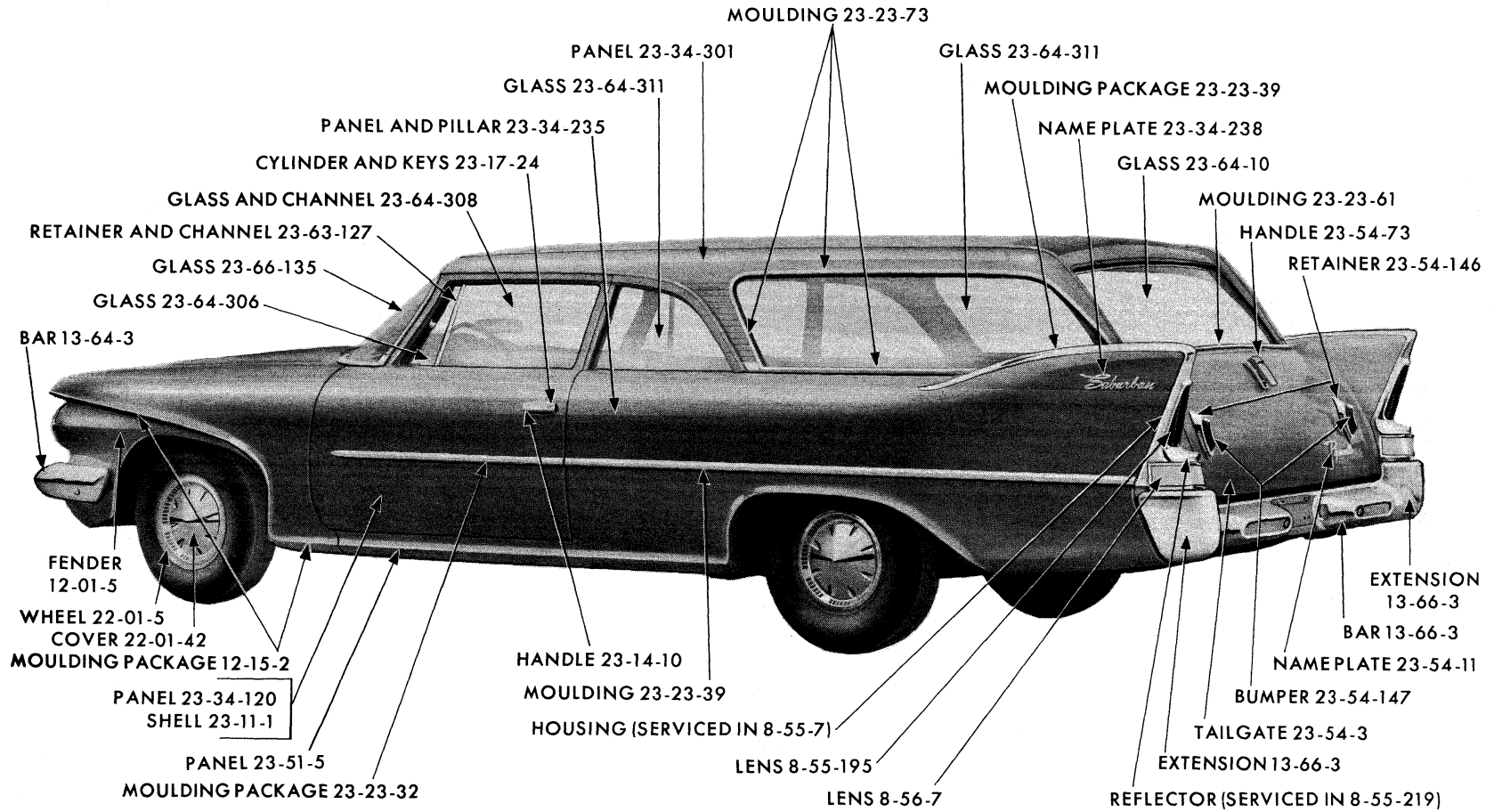

19x8652A

REAR EXTERIOR - PLYMOUTH PP1-2 2 DOOR SUBURBAN

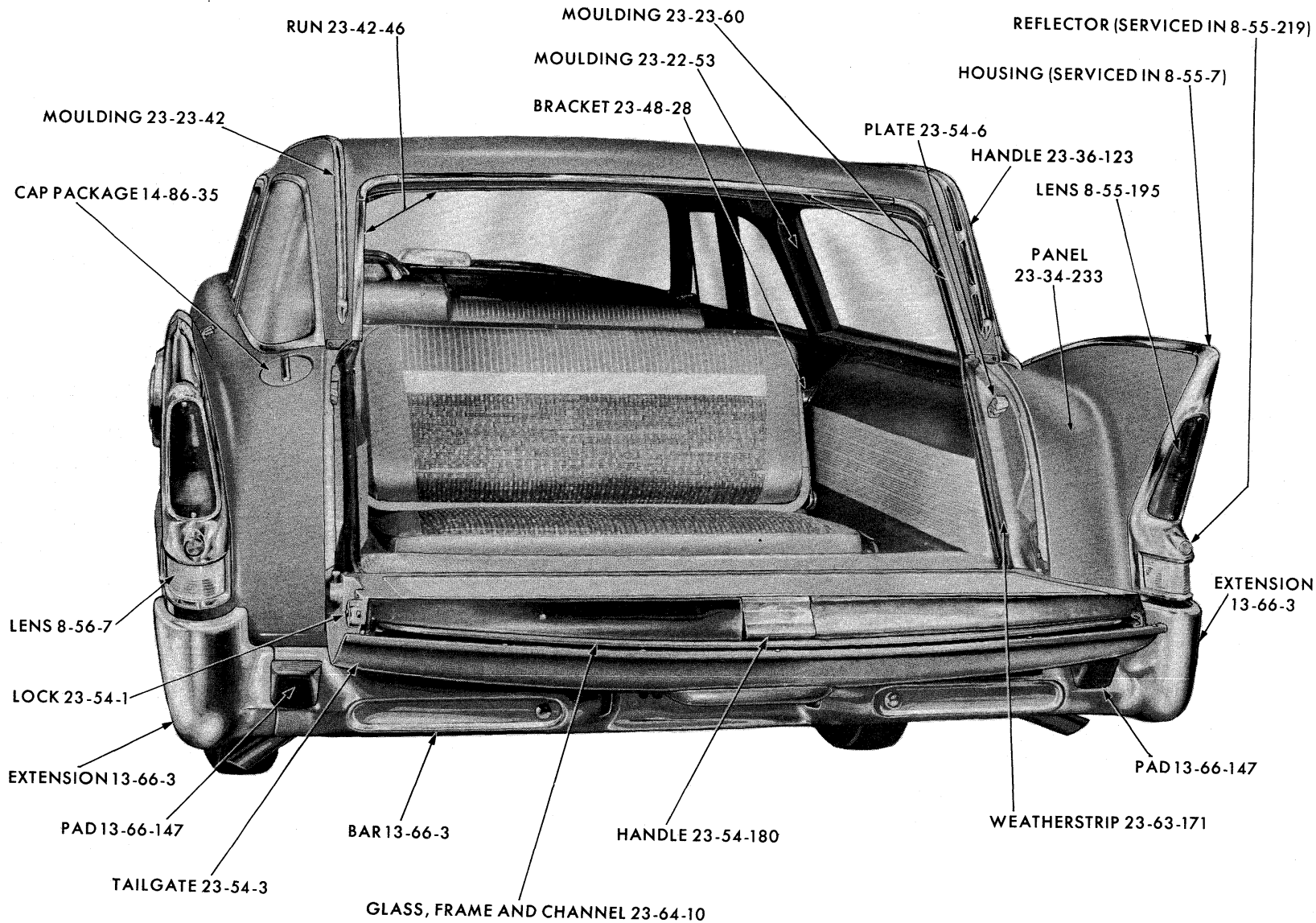

19x8643A

REAR VIEW - PLYMOUTH PP1-2 SUBURBAN

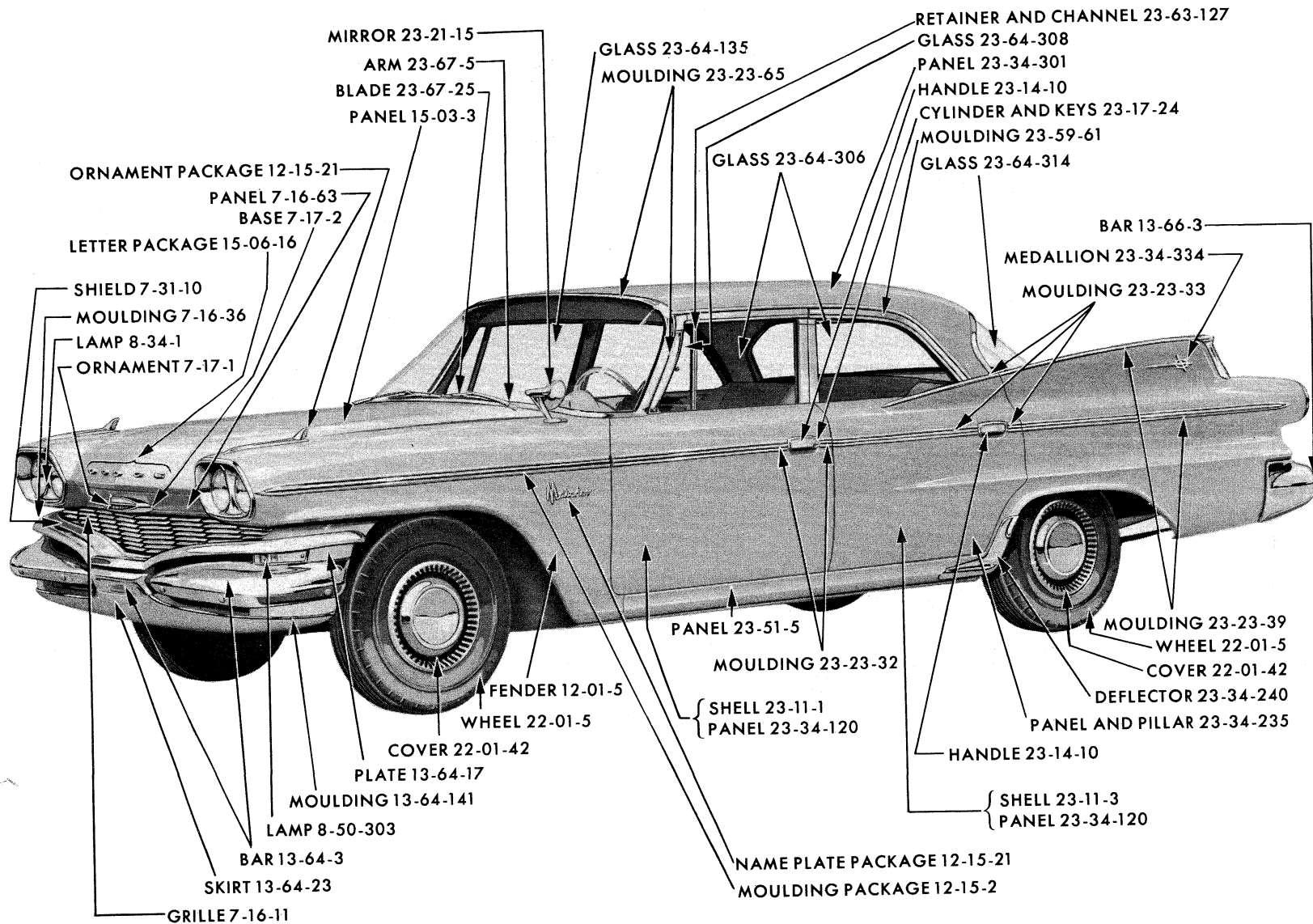

FRONT EXTERIOR - DODGE PD1-2 4 DOOR SEDAN

19x8790

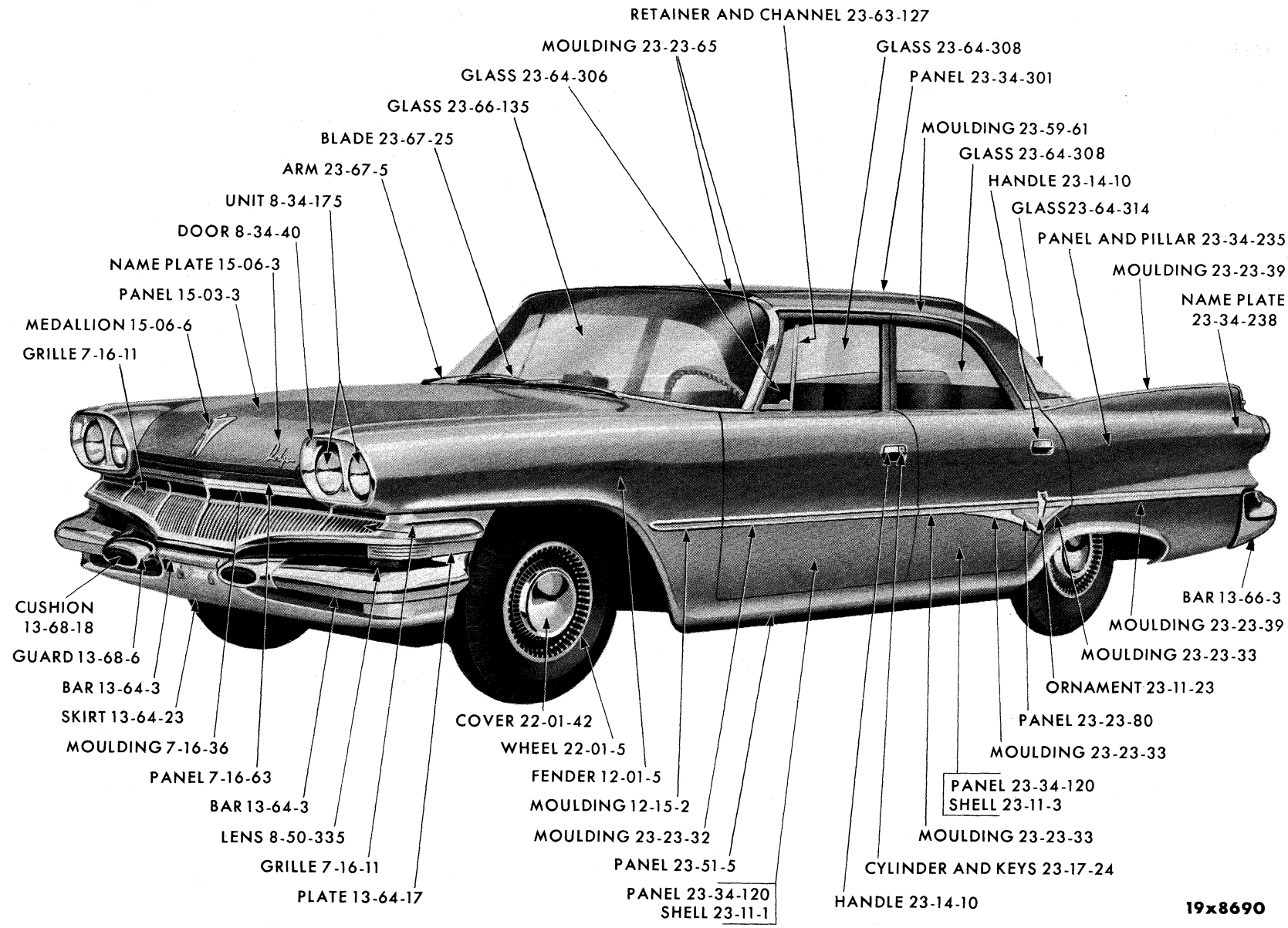

FRONT EXTERIOR - DODGE PDS-4 4 DOOR SEDAN

19x8690

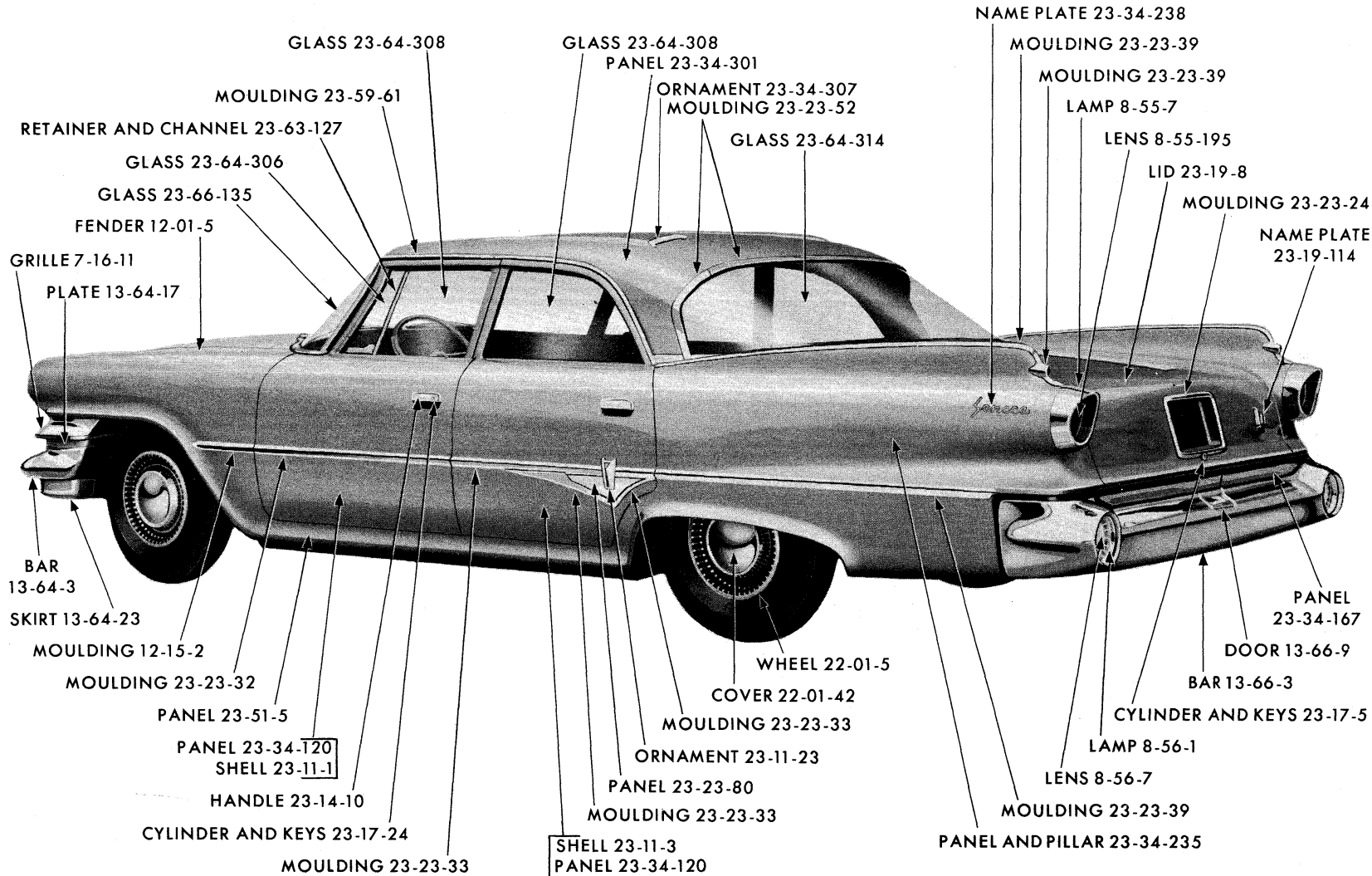

19x8689A

REAR EXTERIOR - DODGE PD3-4 4 DOOR SEDAN

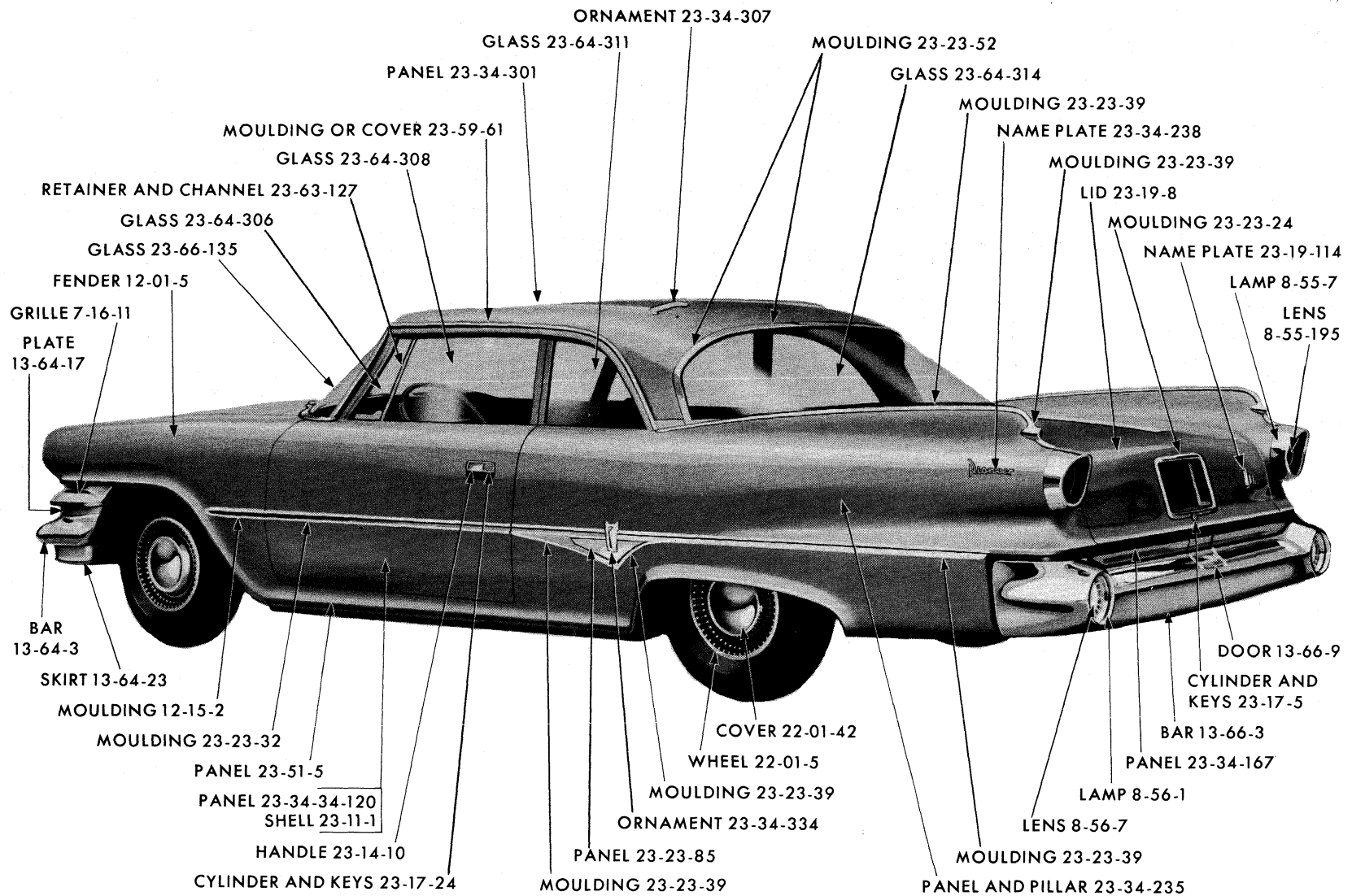

19x8693A

REAR EXTERIOR - DODGE PD3-4 CLUB SEDAN

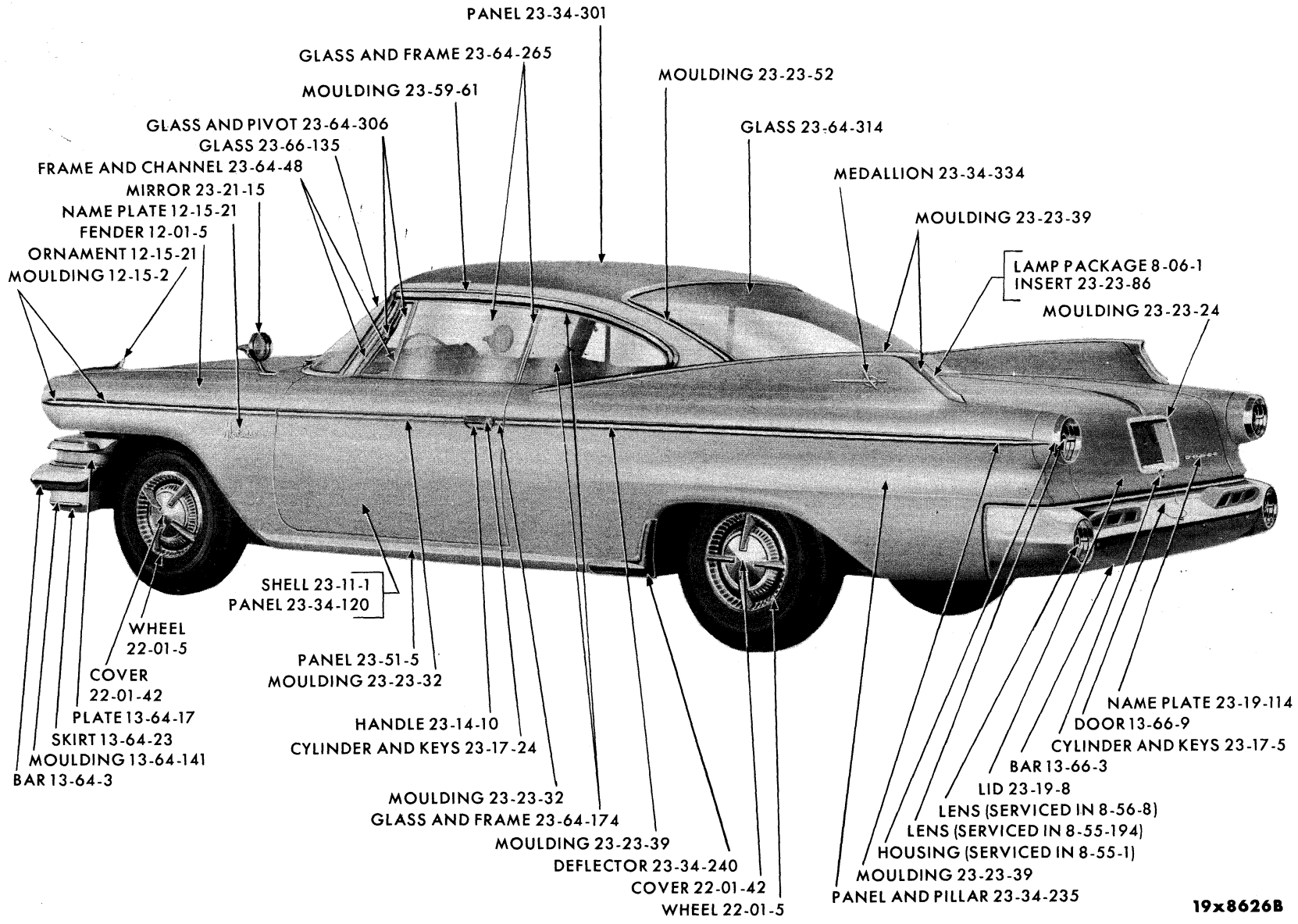

REAR EXTERIOR - DODGE PD1-2 SPECIAL CLUB COUPE

19x8626B

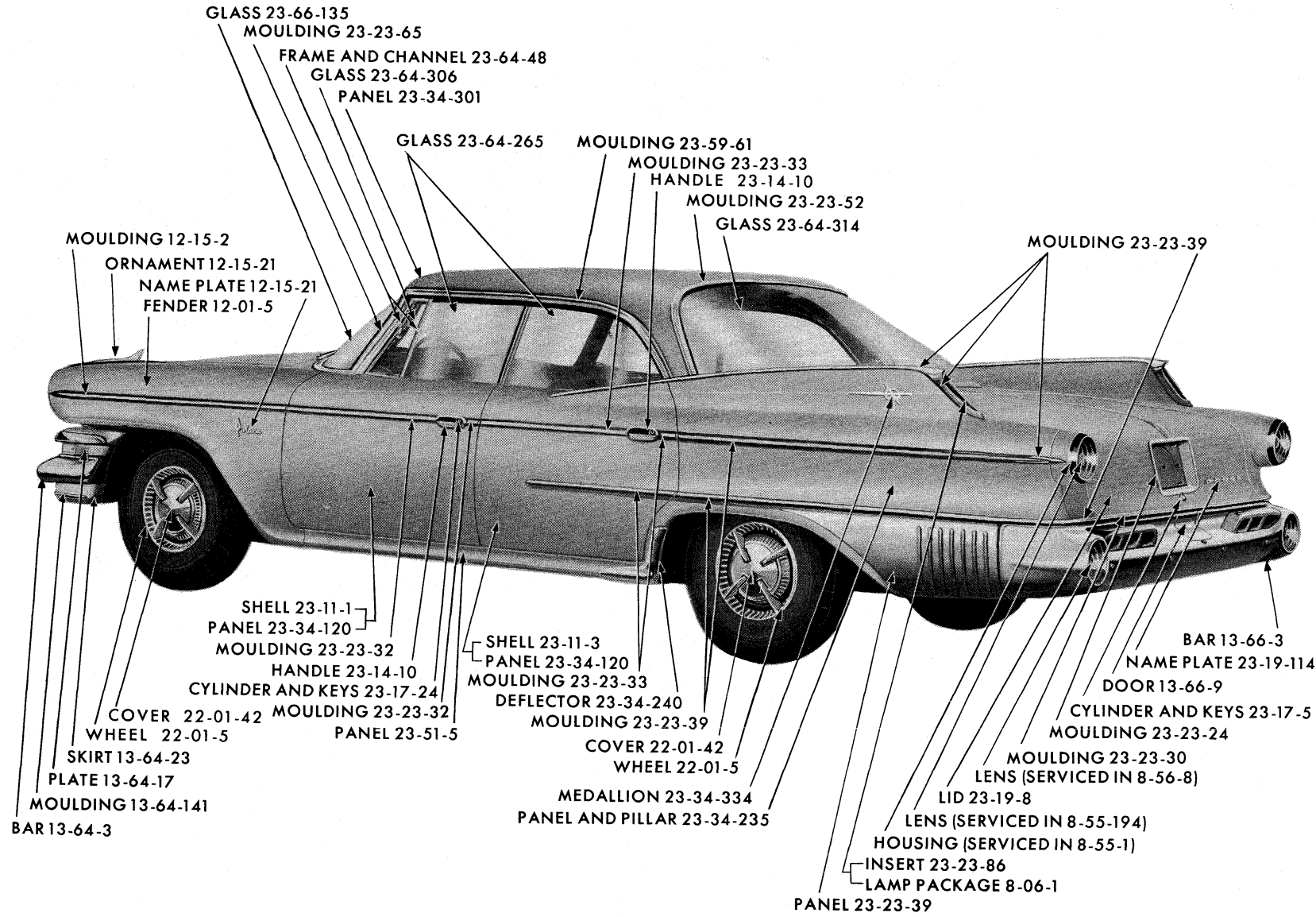

19x8625B

REAR EXTERIOR - DODGE PD1-2 SPECIAL 4 DOOR SEDAN

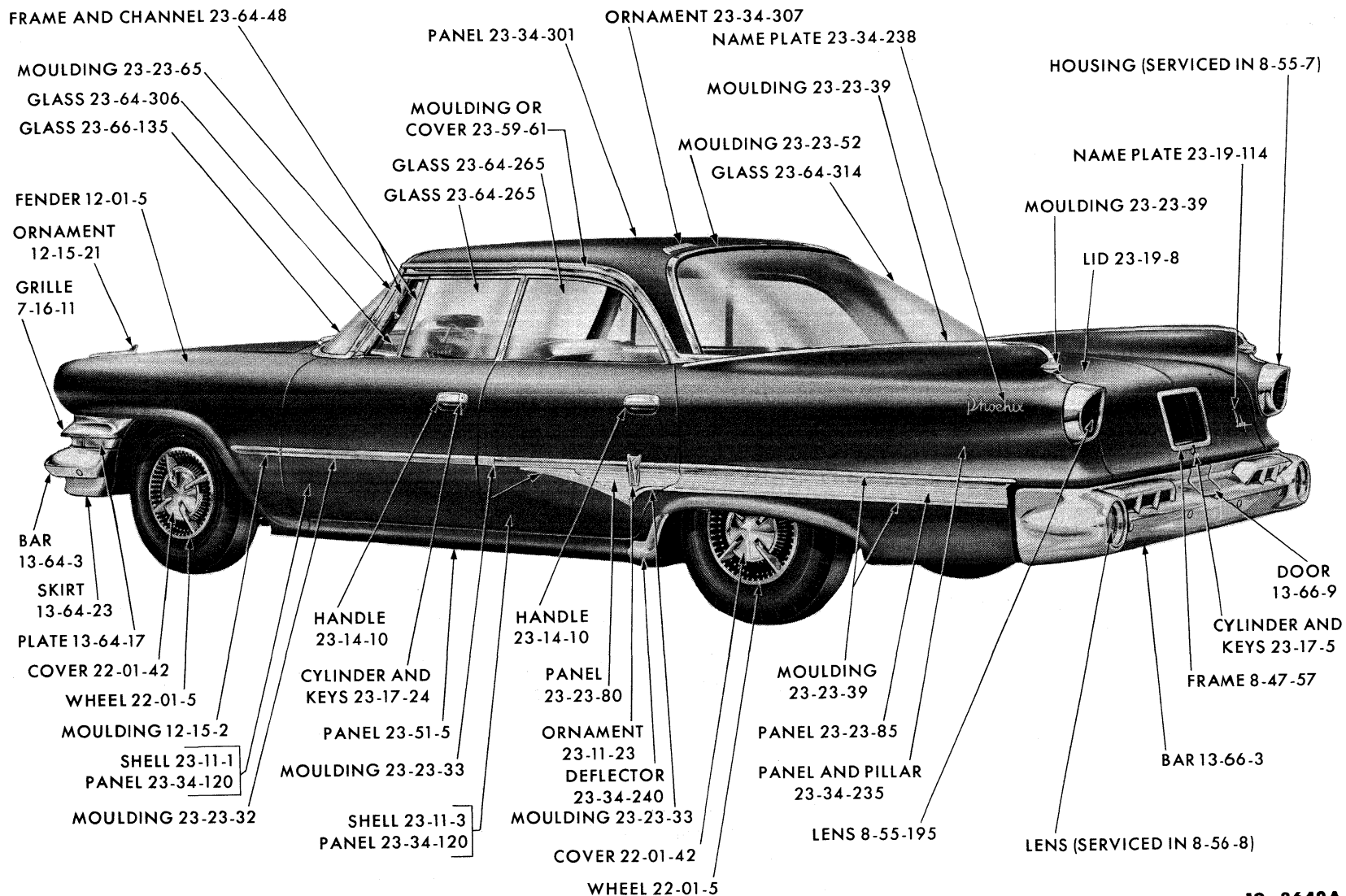

19x8642A

REAR EXTERIOR - DODGE PDS-4 SPECIAL 4 DOOR SEDAN

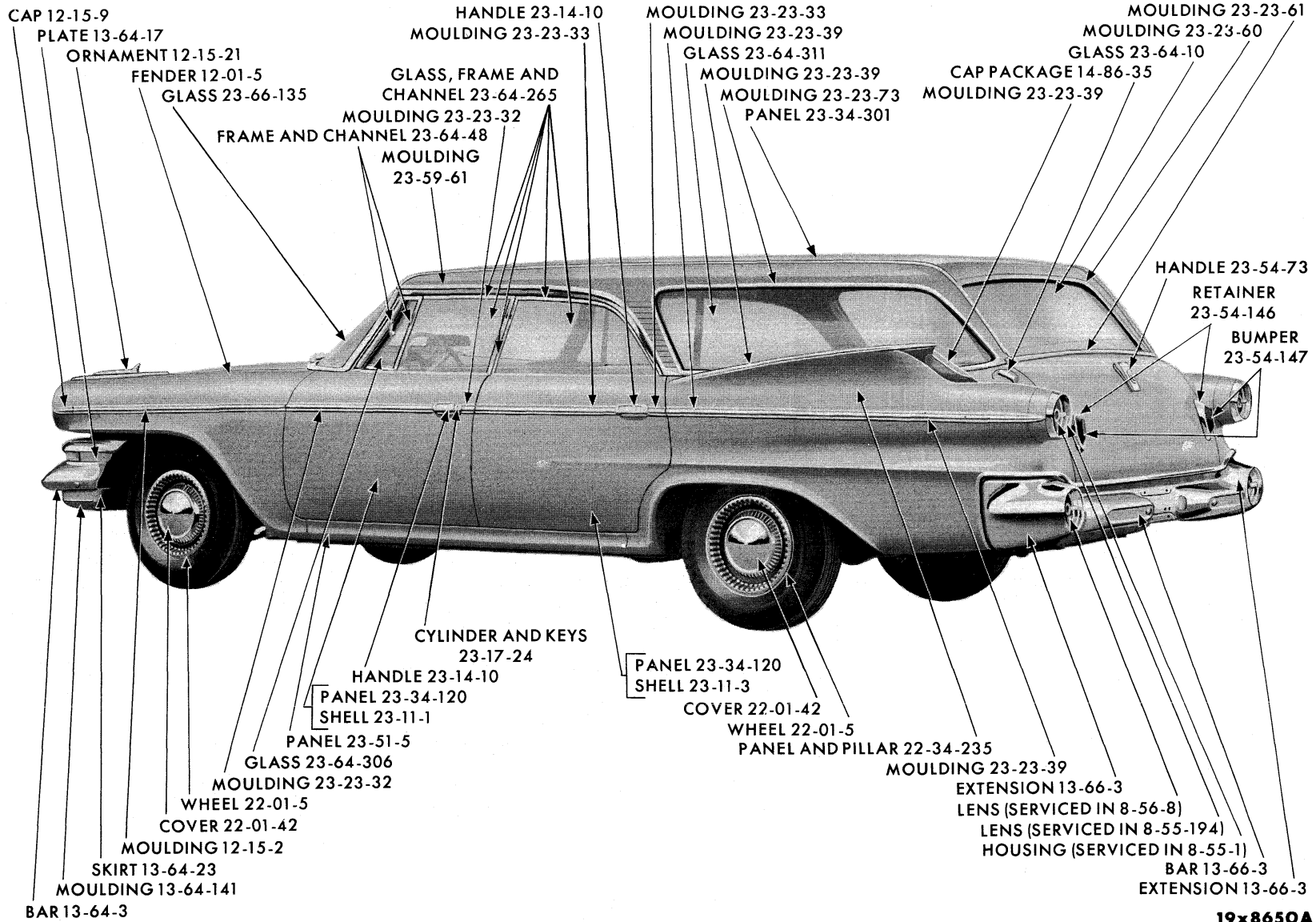

REAR EXTERIOR - DODGE PD1-2 4 DOOR SUBURBAN

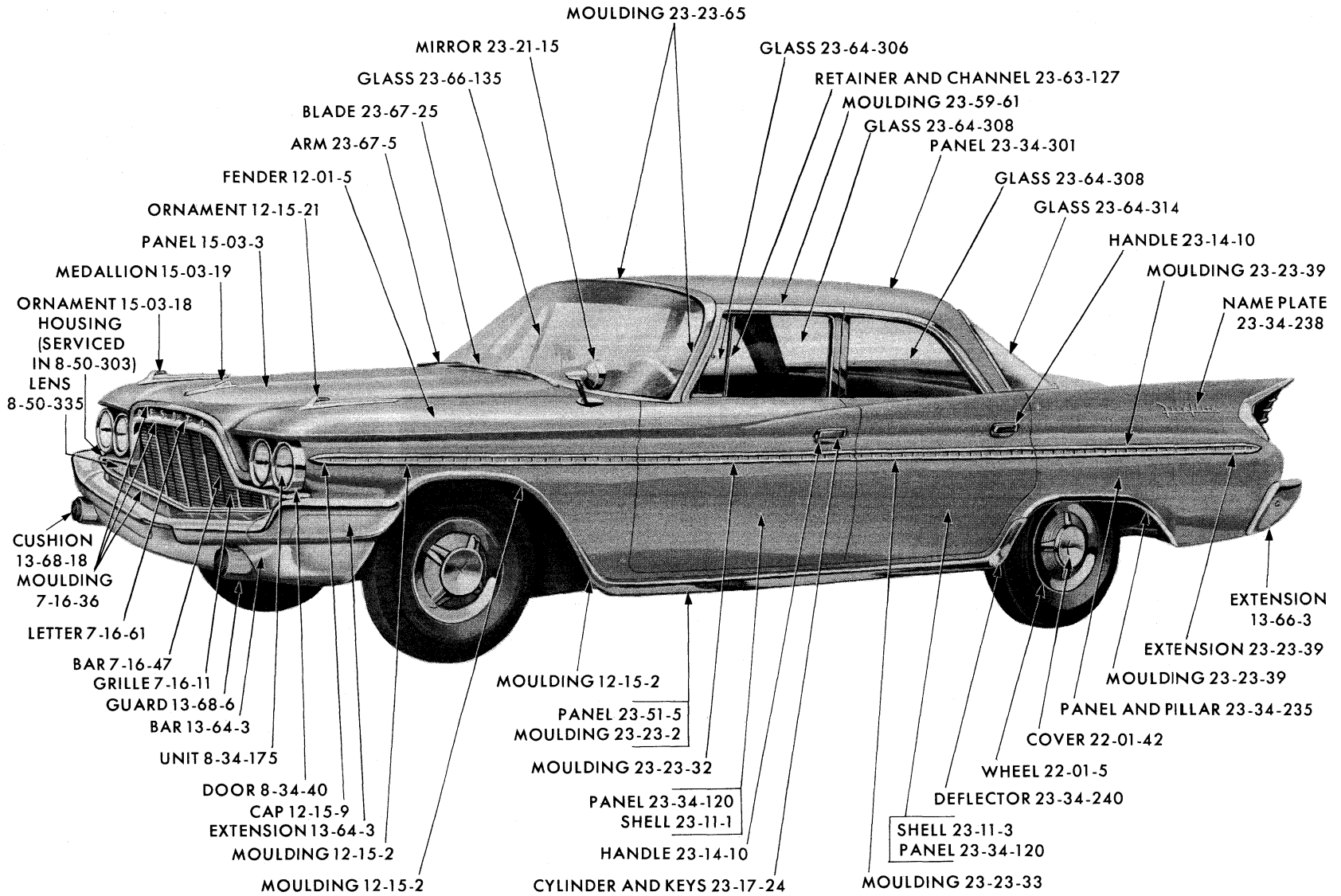

- MOULDING 23-23-65
- MIRROR 23-21-15
- GLASS 23-66-135
- GLASS 23-64-306
- BLADE 23-67-25
- ARM 23-67-5
- RETAINER AND CHANNEL 23-63-127
- MOULDING 23-59-61
- GLASS 23-64-308
- PANEL 23-34-301
- FENDER 12-01-5
- GLASS 23-64-308
- GLASS 23-64-314
- ORNAMENT 12-15-21
- PANEL 15-03-3
- HANDLE 23-14-10
- MEDALLION 15-03-19
- ORNAMENT 15-03-18
- HOUSING (SERVICED IN 8-50-303)
- LENS 8-50-335
- MOULDING 23-23-39
- NAME PLATE 23-34-238
- CUSHION 13-68-18
- MOULDING 7-16-36
- LETTER 7-16-61
- BAR 7-16-47
- GRILLE 7-16-11
- GUARD 13-68-6
- BAR 13-64-3
- UNIT 8-34-175
- DOOR 8-34-40
- CAP 12-15-9
- EXTENSION 13-64-3
- MOULDING 12-15-2
- MOULDING 12-15-2
- MOULDING 12-15-2
- PANEL 23-51-5
- MOULDING 23-23-2
- MOULDING 23-23-32
- PANEL 23-34-120
- SHELL 23-11-1
- HANDLE 23-14-10
- CYLINDER AND KEYS 23-17-24
- GLASS 23-64-308
- RETAINER AND CHANNEL 23-63-127
- MOULDING 23-59-61
- GLASS 23-64-308
- PANEL 23-34-301
- GLASS 23-64-308
- GLASS 23-64-314
- HANDLE 23-14-10
- MOULDING 23-23-39
- NAME PLATE 23-34-238
- EXTENSION 13-66-3
- EXTENSION 23-23-39
- MOULDING 23-23-39
- PANEL AND PILLAR 23-34-235
- COVER 22-01-42
- WHEEL 22-01-5
- DEFLECTOR 23-34-240
- SHELL 23-11-3
- PANEL 23-34-120
- MOULDING 23-23-33

19x8660B

FRONT EXTERIOR - DESOTO PS1-3 4 DOOR SEDAN

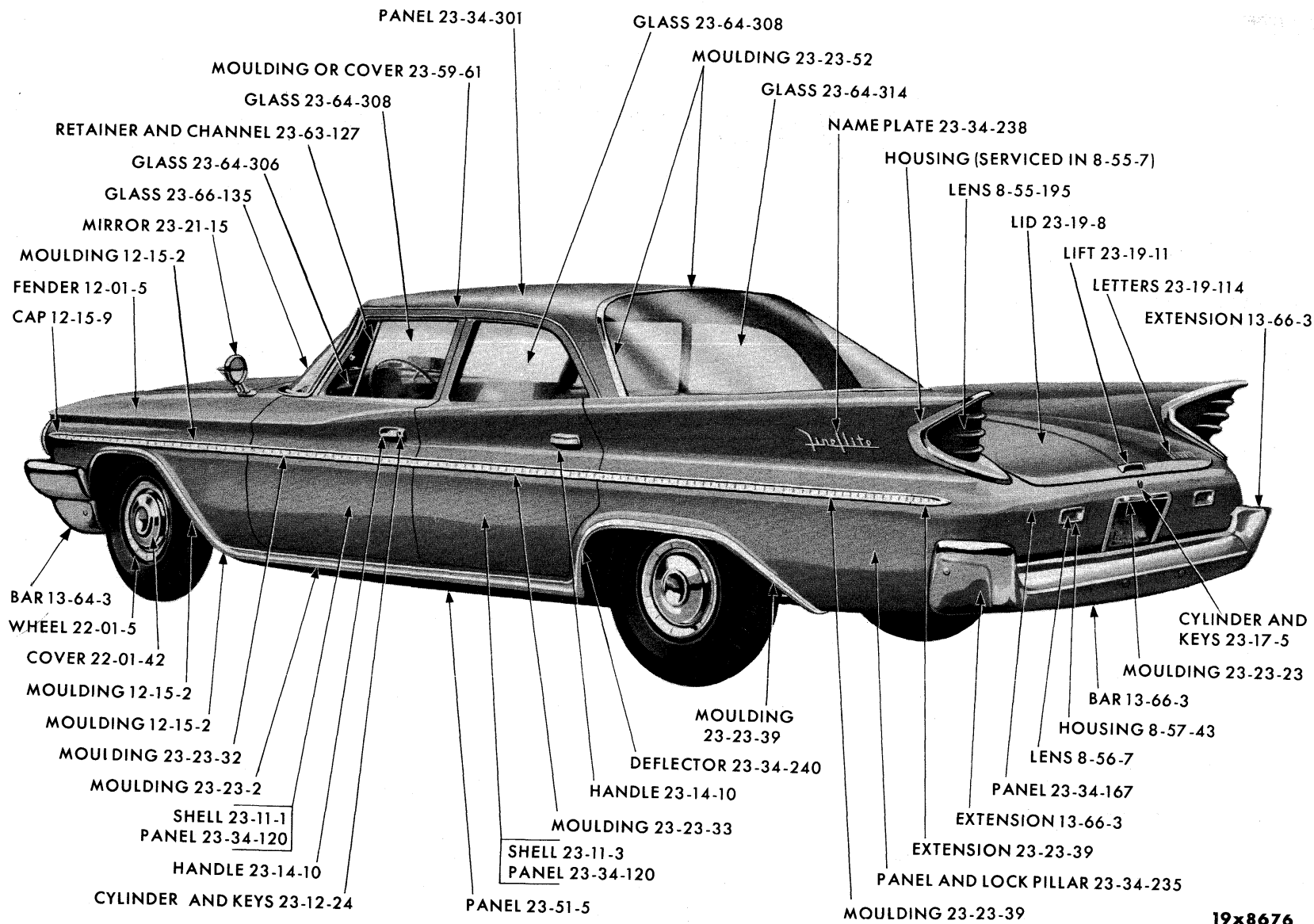

19x8676

REAR EXTERIOR - DESOTO PSI-3 4 DOOR SEDAN

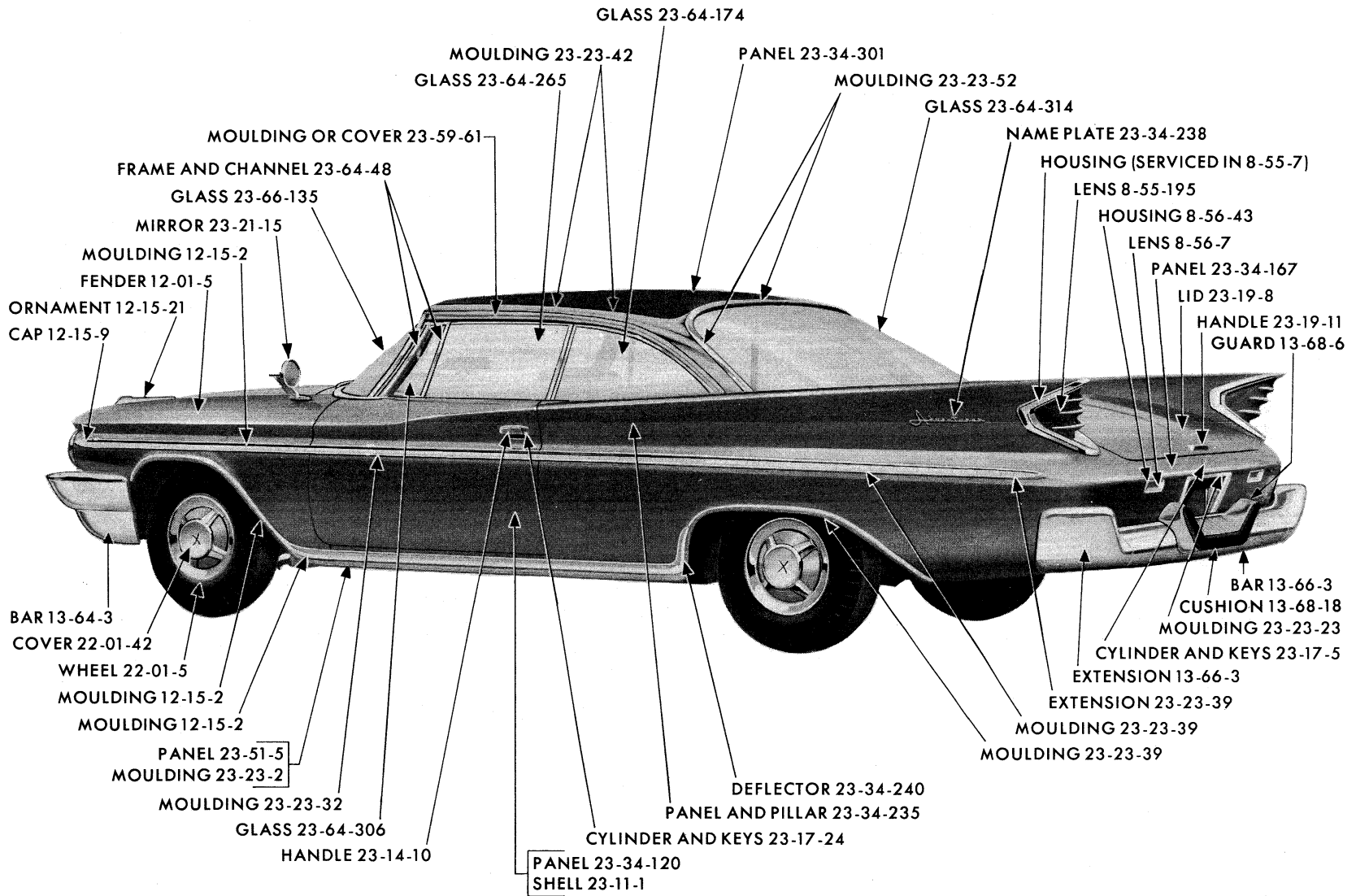

19x8653B

REAR EXTERIOR - DESOTO PS1-3 SPECIAL CLUB COUPE

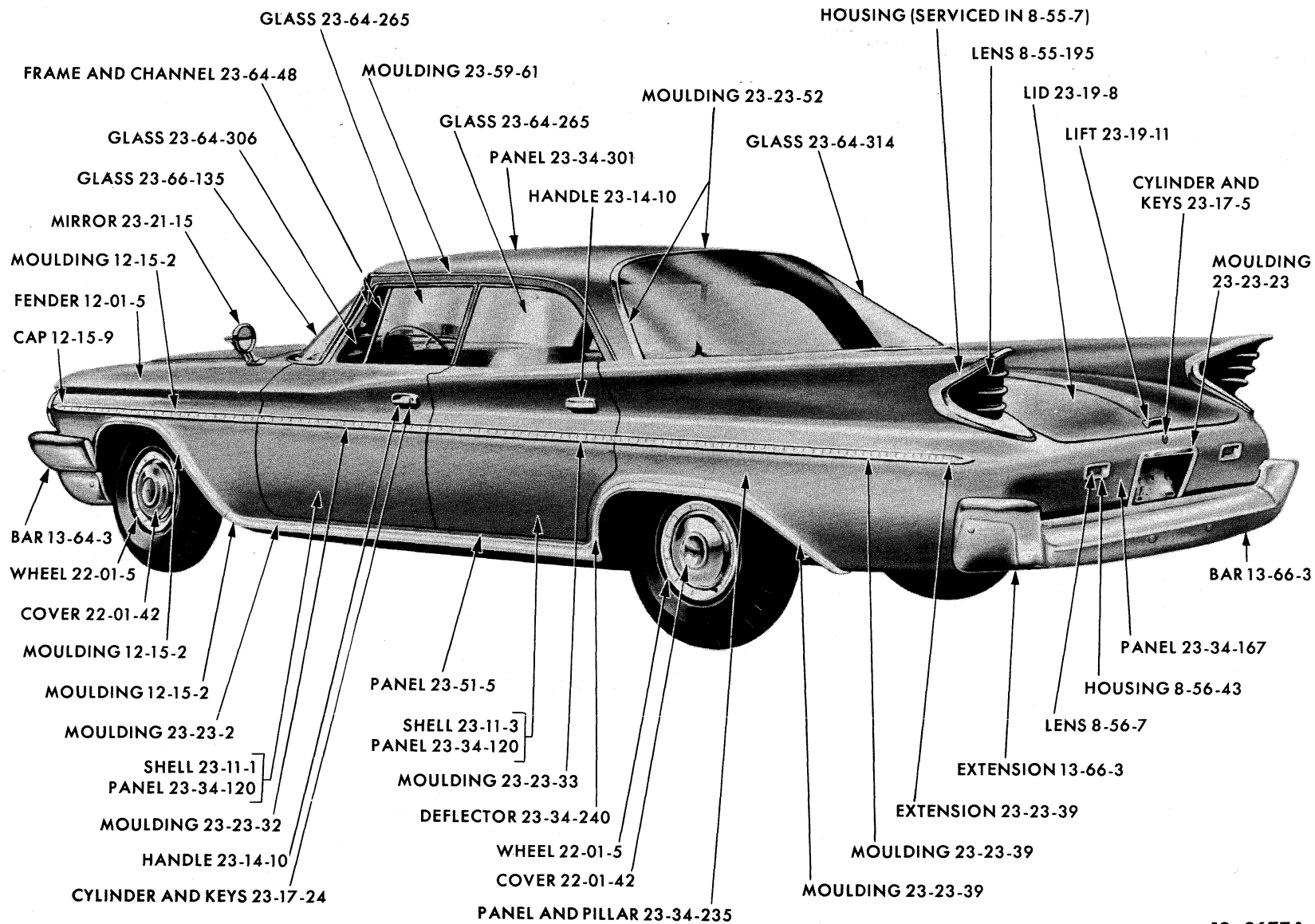

19x8677A

REAR EXTERIOR - DESOTO PS1-3 SPECIAL 4 DOOR SEDAN

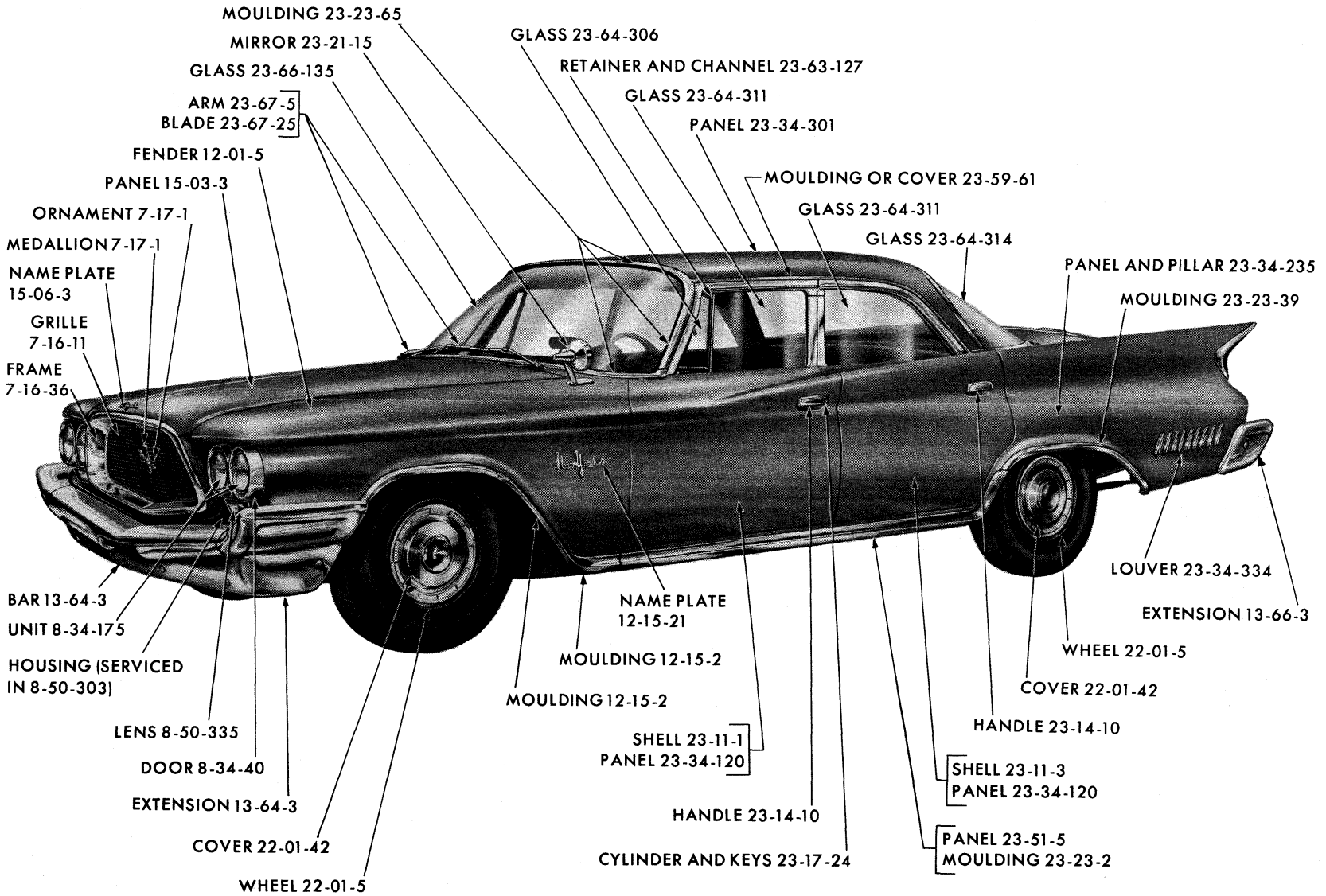

19x8630

FRONT EXTERIOR - CHRYSLER PC1-2-3 4 DOOR SEDAN

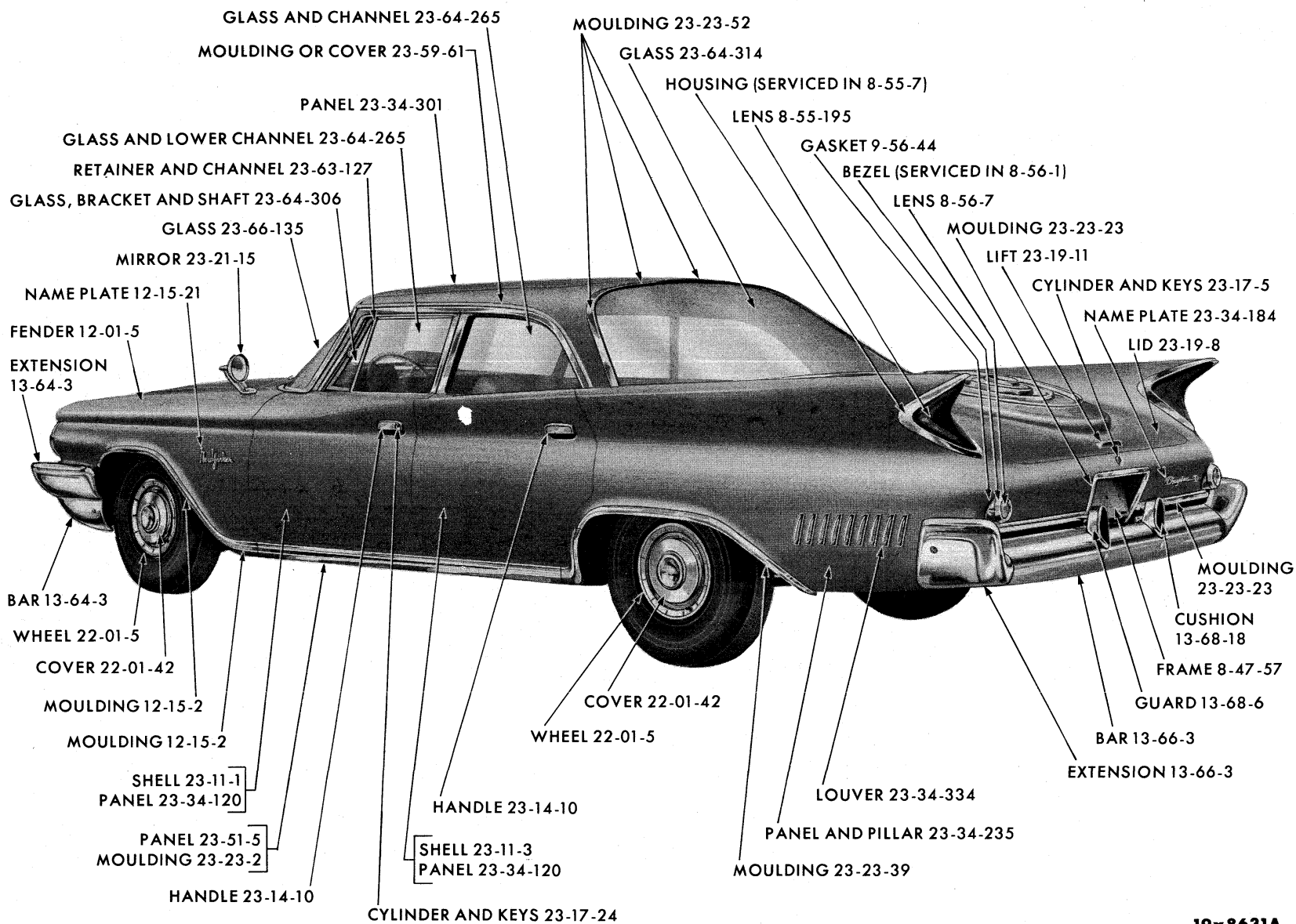

19x8631A

REAR EXTERIOR - CHRYSLER PC1-2-3 4 DOOR SEDAN

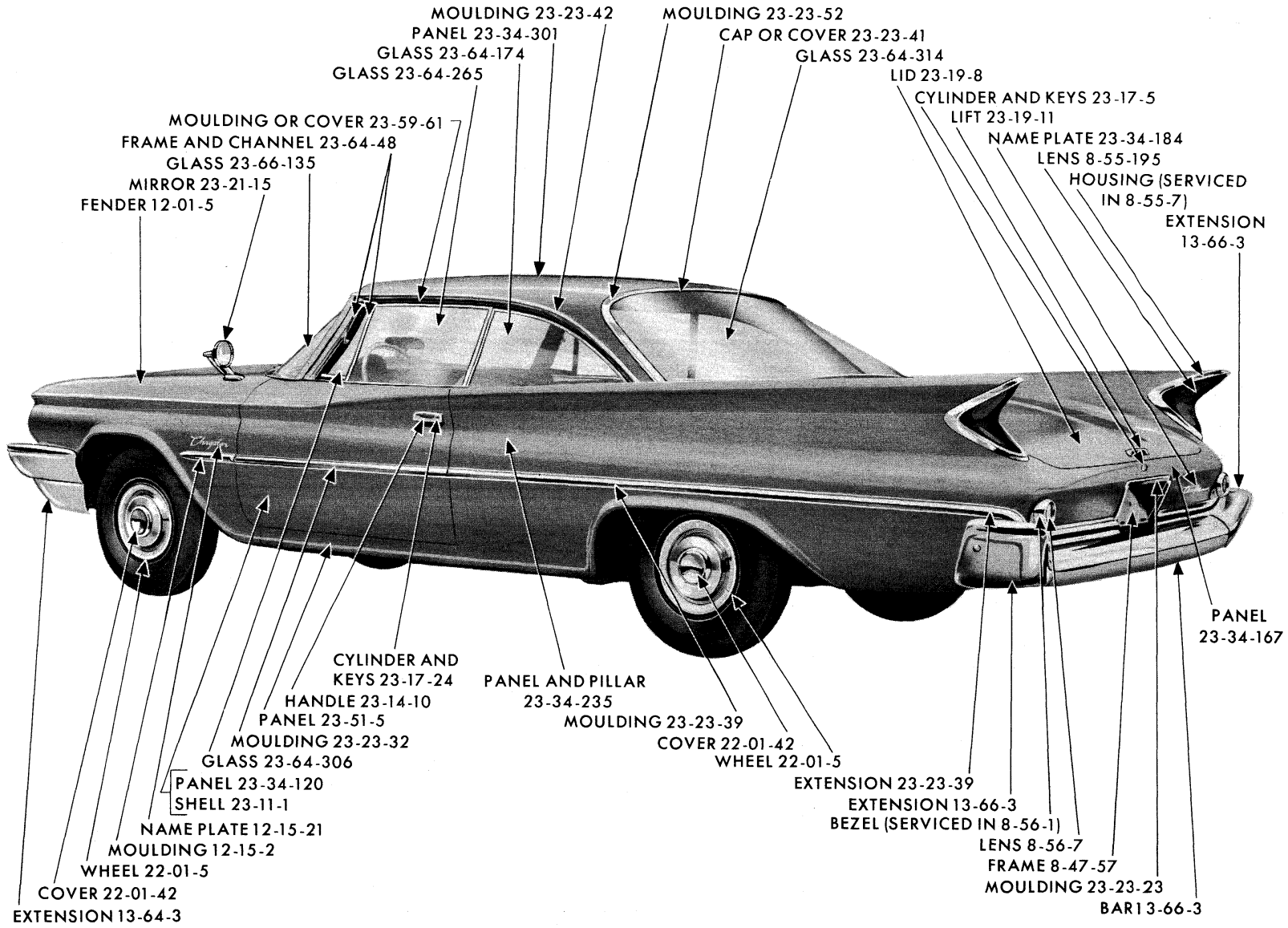

19x8646A

REAR EXTERIOR - CHRYSLER PC1-2-3 SPECIAL CLUB COUPE

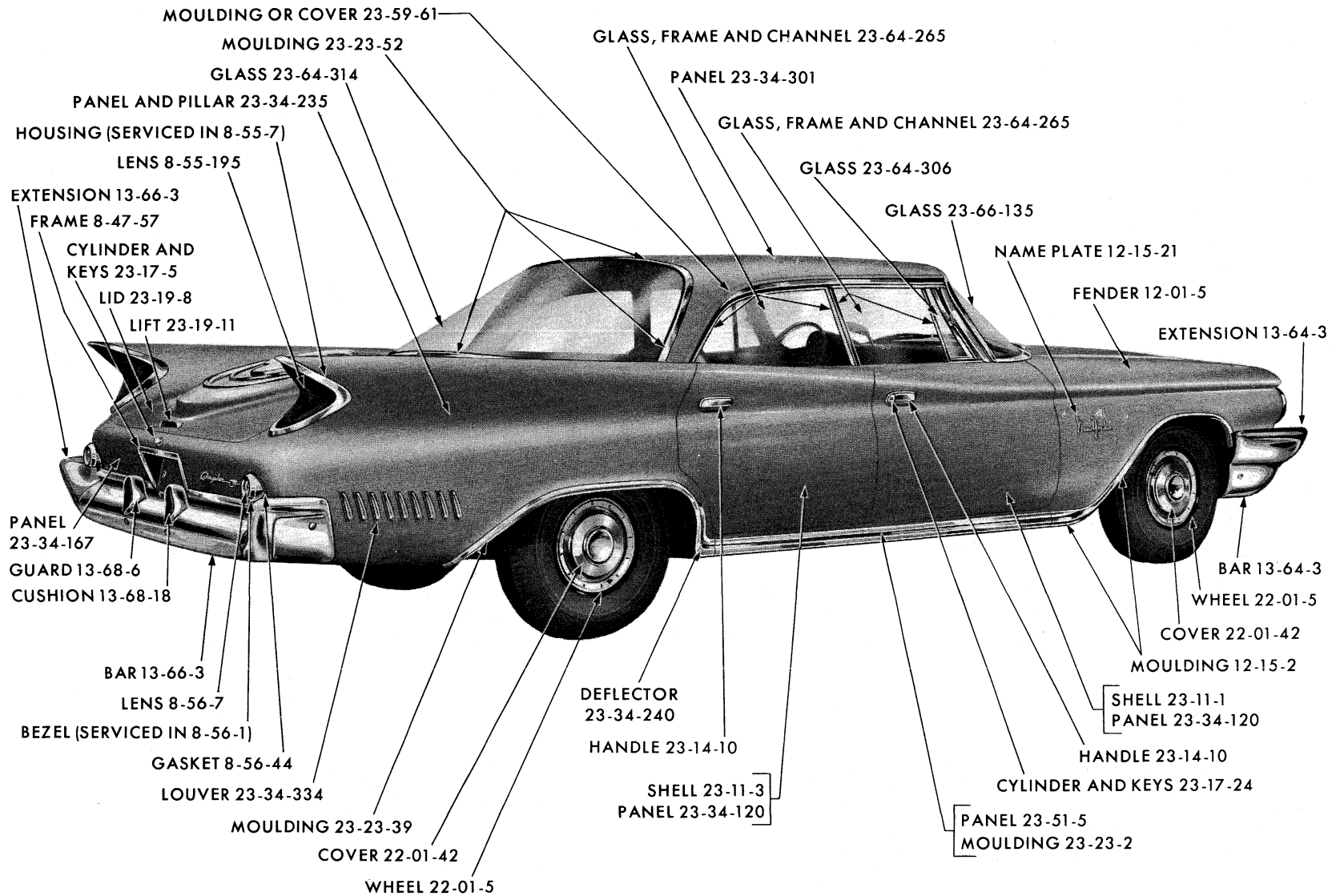

19x8629

REAR EXTERIOR - CHRYSLER PC1-2-3 SPECIAL 4 DOOR SEDAN

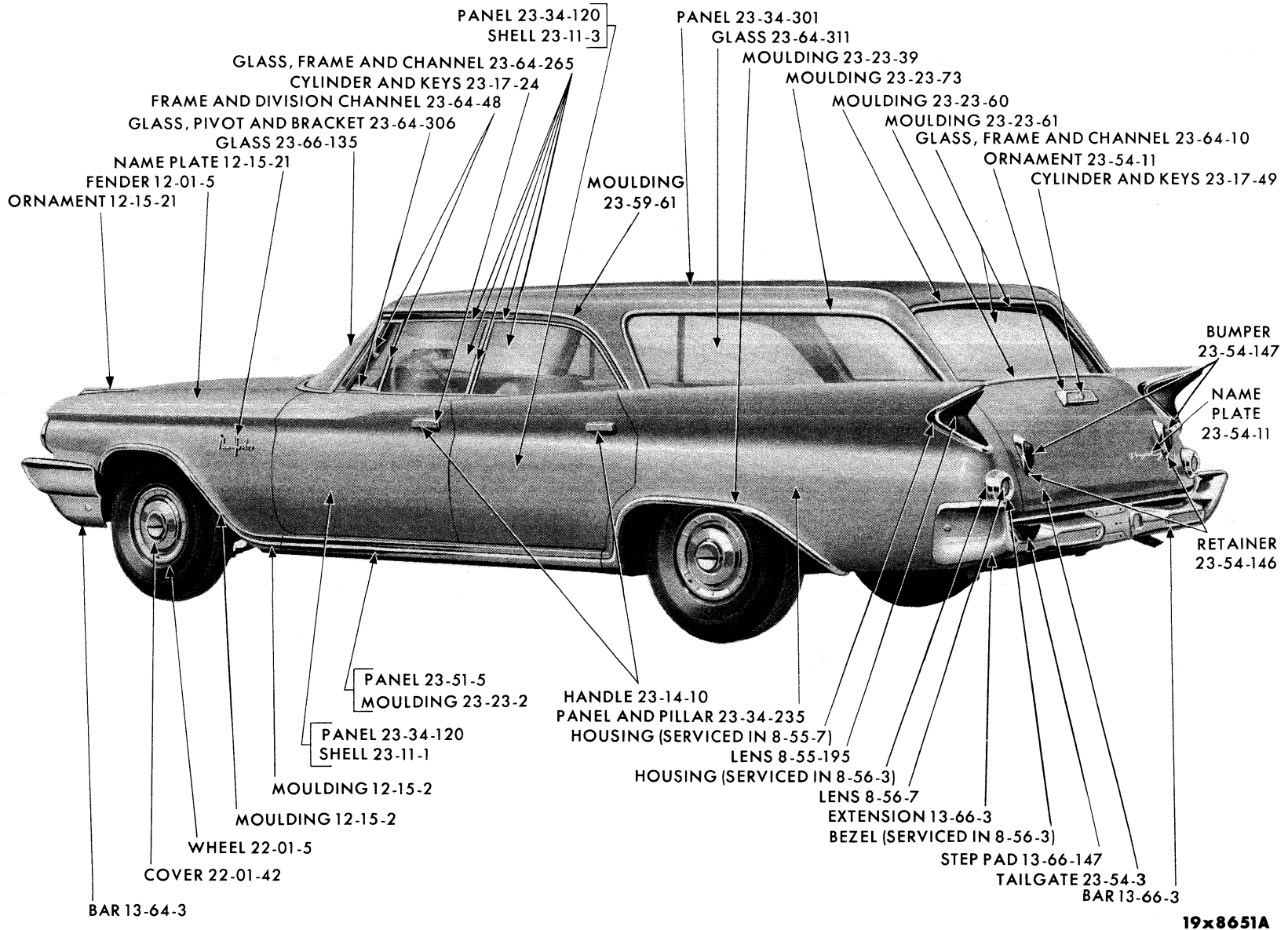

19x8651A

REAR EXTERIOR - CHRYSLER PC1-2-3 SPECIAL 4 DOOR SUBURBAN

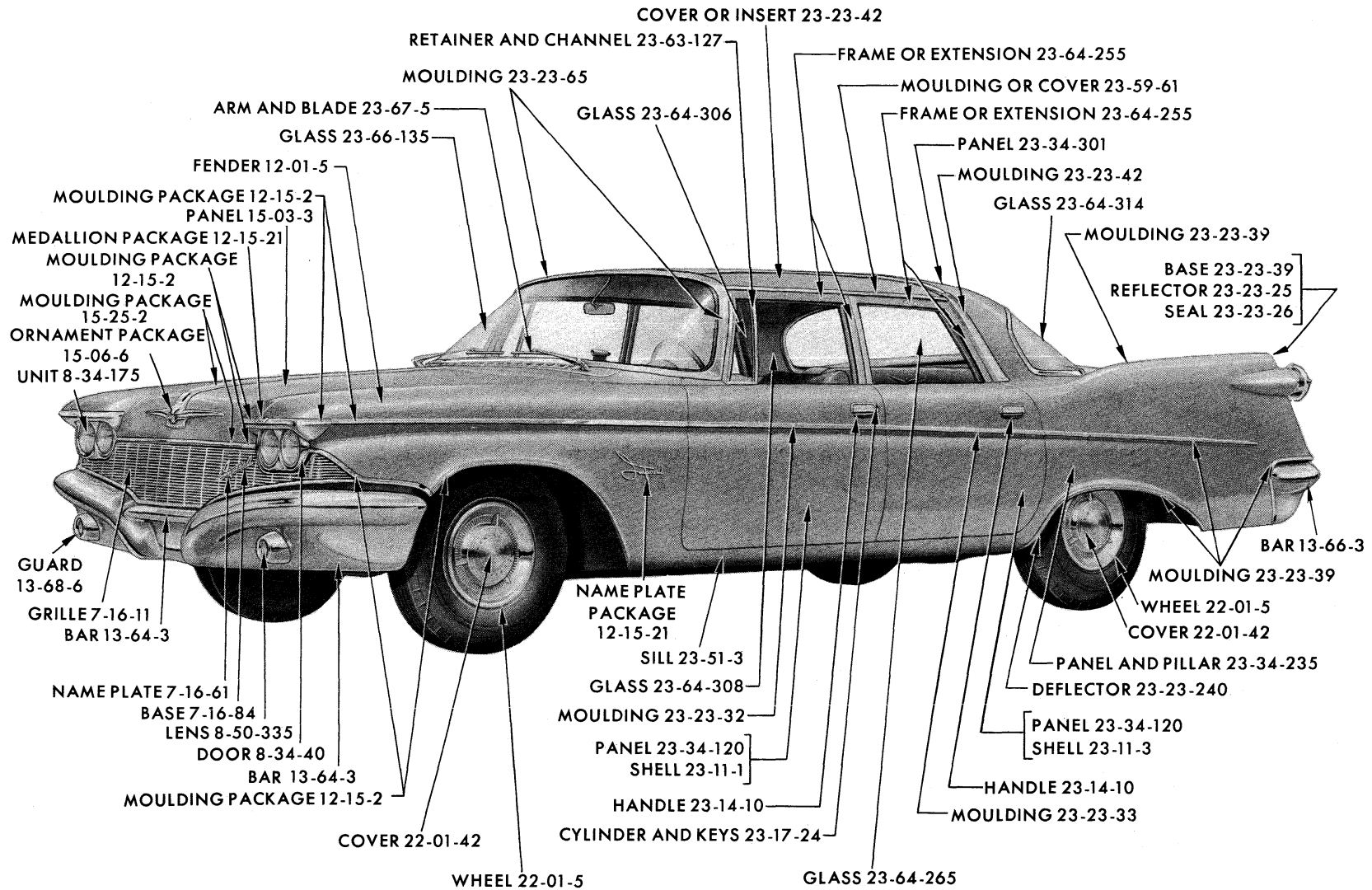

19x8659B

FRONT EXTERIOR - IMPERIAL PY1 4 DOOR SEDAN

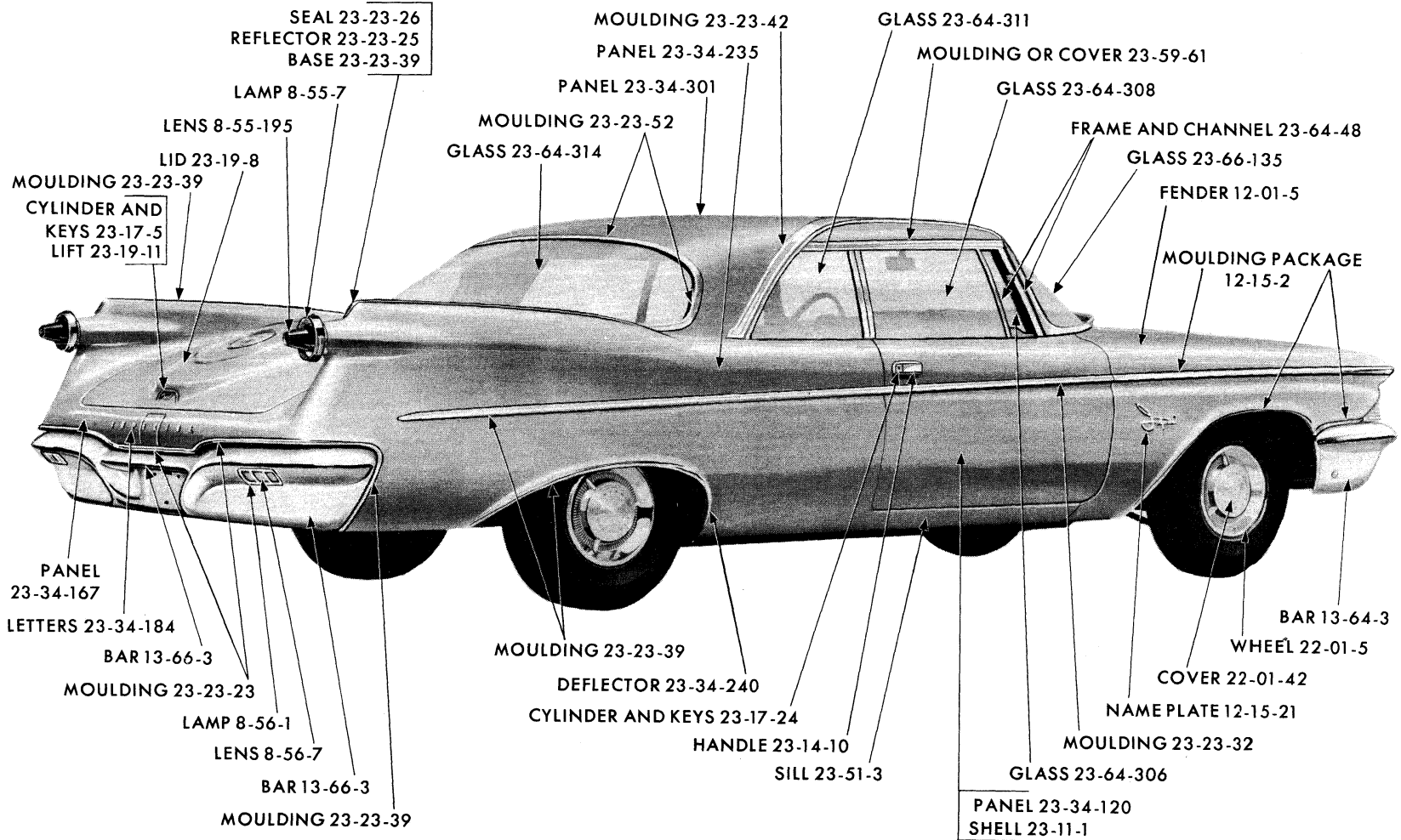

SEAL 23-23-26
REFLECTOR 23-23-25
BASE 23-23-39

MOULDING 23-23-42
PANEL 23-34-235

GLASS 23-64-311
MOULDING OR COVER 23-59-61

LAMP 8-55-7

PANEL 23-34-301

GLASS 23-64-308

LENS 8-55-195

MOULDING 23-23-52

FRAME AND CHANNEL 23-64-48

LID 23-19-8

GLASS 23-64-314

GLASS 23-66-135

MOULDING 23-23-39

CYLINDER AND
KEYS 23-17-5
LIFT 23-19-11

FENDER 12-01-5

MOULDING PACKAGE
12-15-2

PANEL
23-34-167

LETTERS 23-34-184

BAR 13-66-3

MOULDING 23-23-23

LAMP 8-56-1

LENS 8-56-7

BAR 13-66-3

MOULDING 23-23-39

MOULDING 23-23-39

DEFLECTOR 23-34-240

CYLINDER AND KEYS 23-17-24

HANDLE 23-14-10

SILL 23-51-3

BAR 13-64-3

WHEEL 22-01-5

COVER 22-01-42

NAME PLATE 12-15-21

MOULDING 23-23-32

GLASS 23-64-306

PANEL 23-34-120
SHELL 23-11-1

19x8688A

REAR EXTERIOR - IMPERIAL PY1 SPECIAL CLUB COUPE

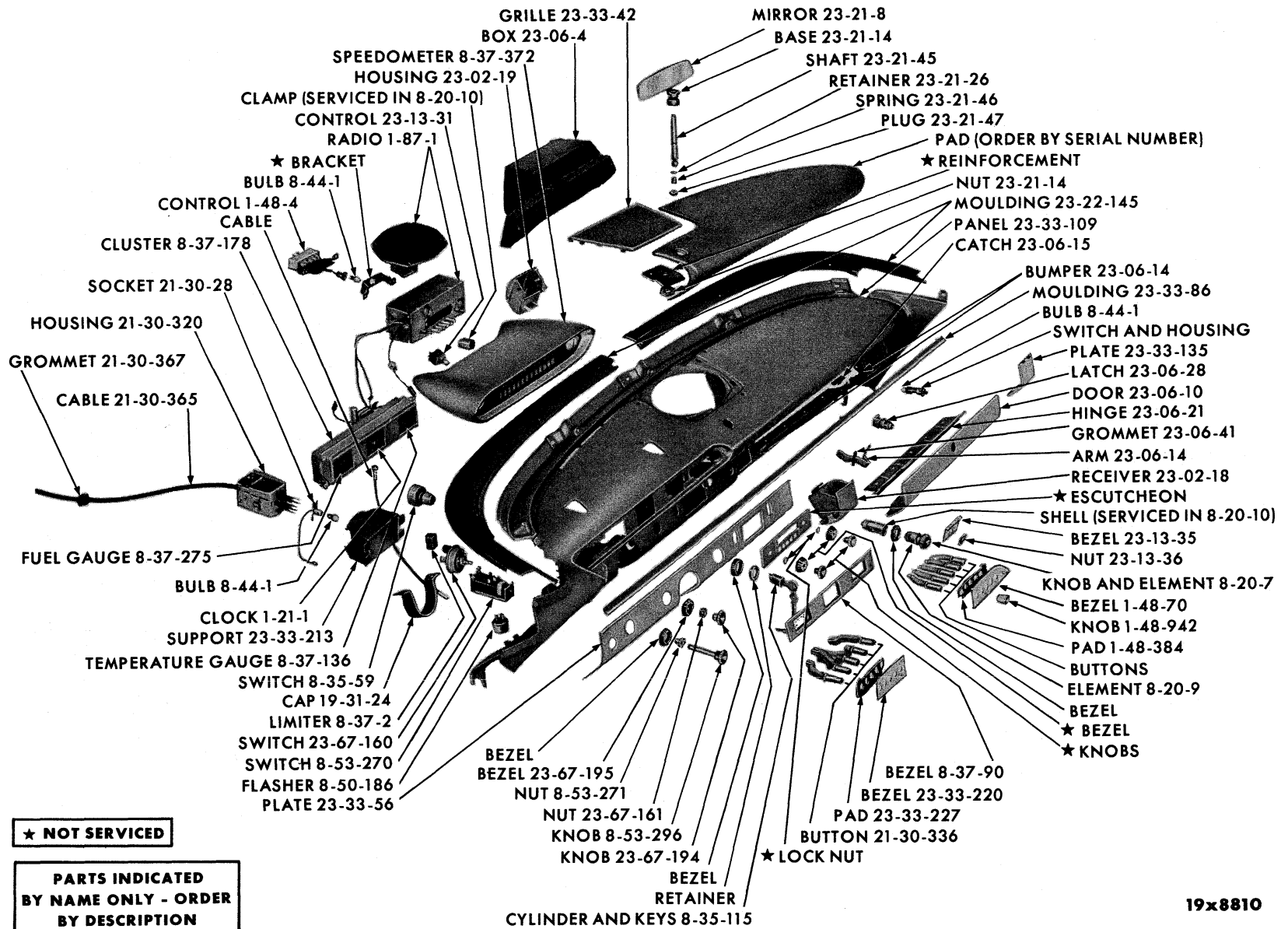

★ NOT SERVICED

PARTS INDICATED
 BY NAME ONLY - ORDER
 BY DESCRIPTION

19x8810

INSTRUMENT PANEL - PLYMOUTH PP1-2

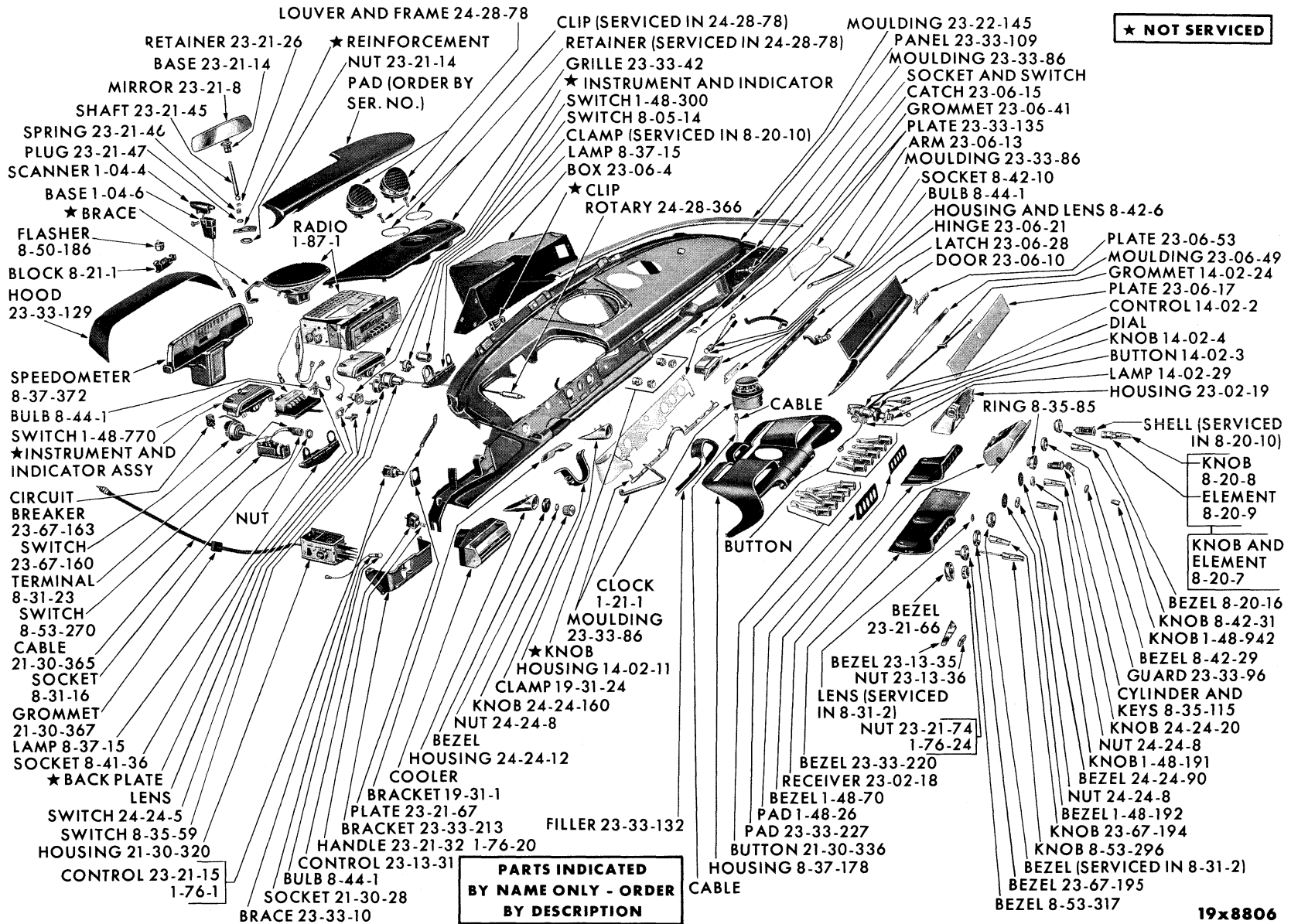

INSTRUMENT PANEL - DODGE PD1-2-3-4

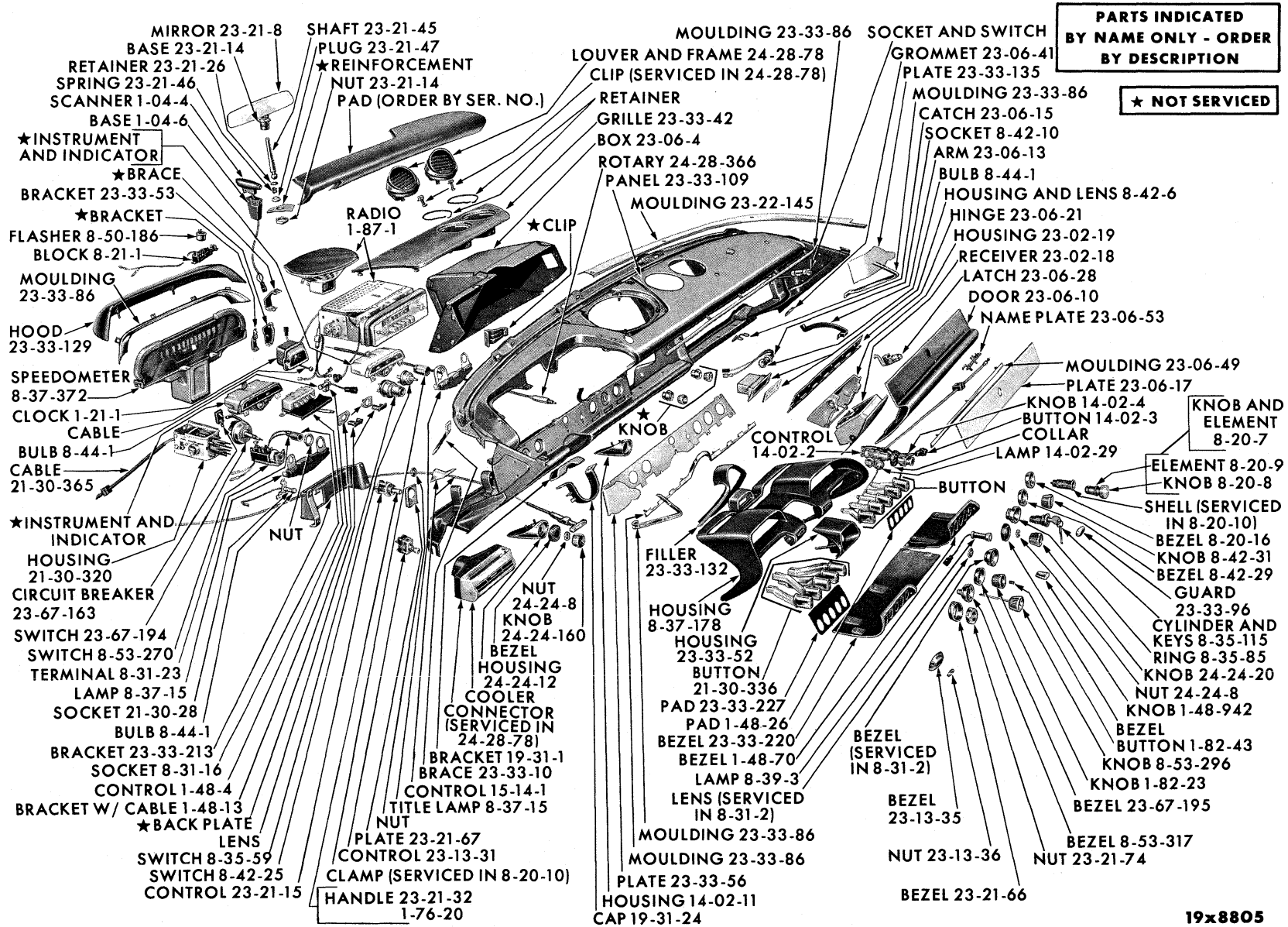

INSTRUMENT PANEL - DESOTO PS1-3

19x8805

PARTS INDICATED BY NAME ONLY - ORDER BY DESCRIPTION

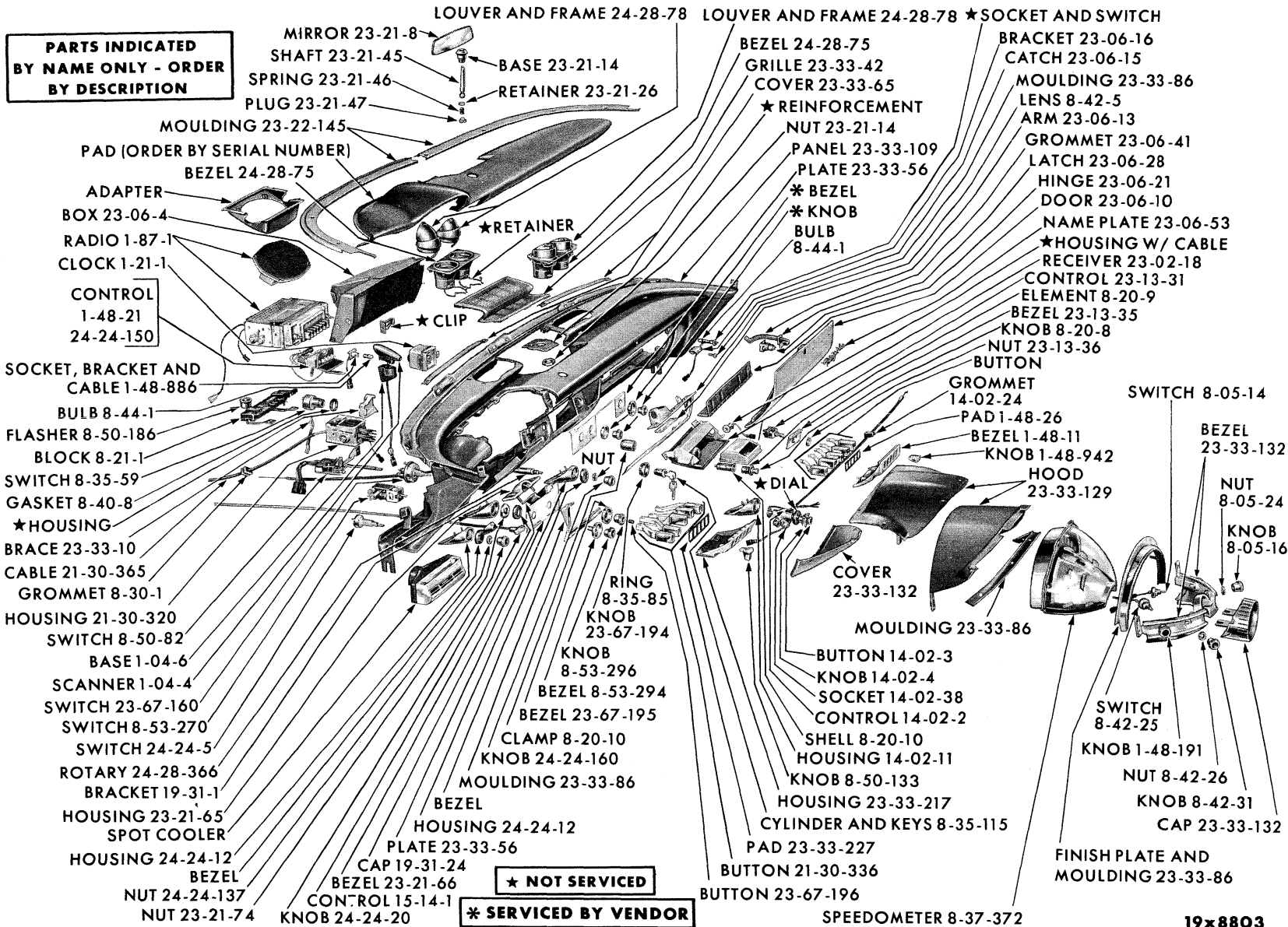

19x8803

INSTRUMENT PANEL - CHRYSLER PC1-2-3

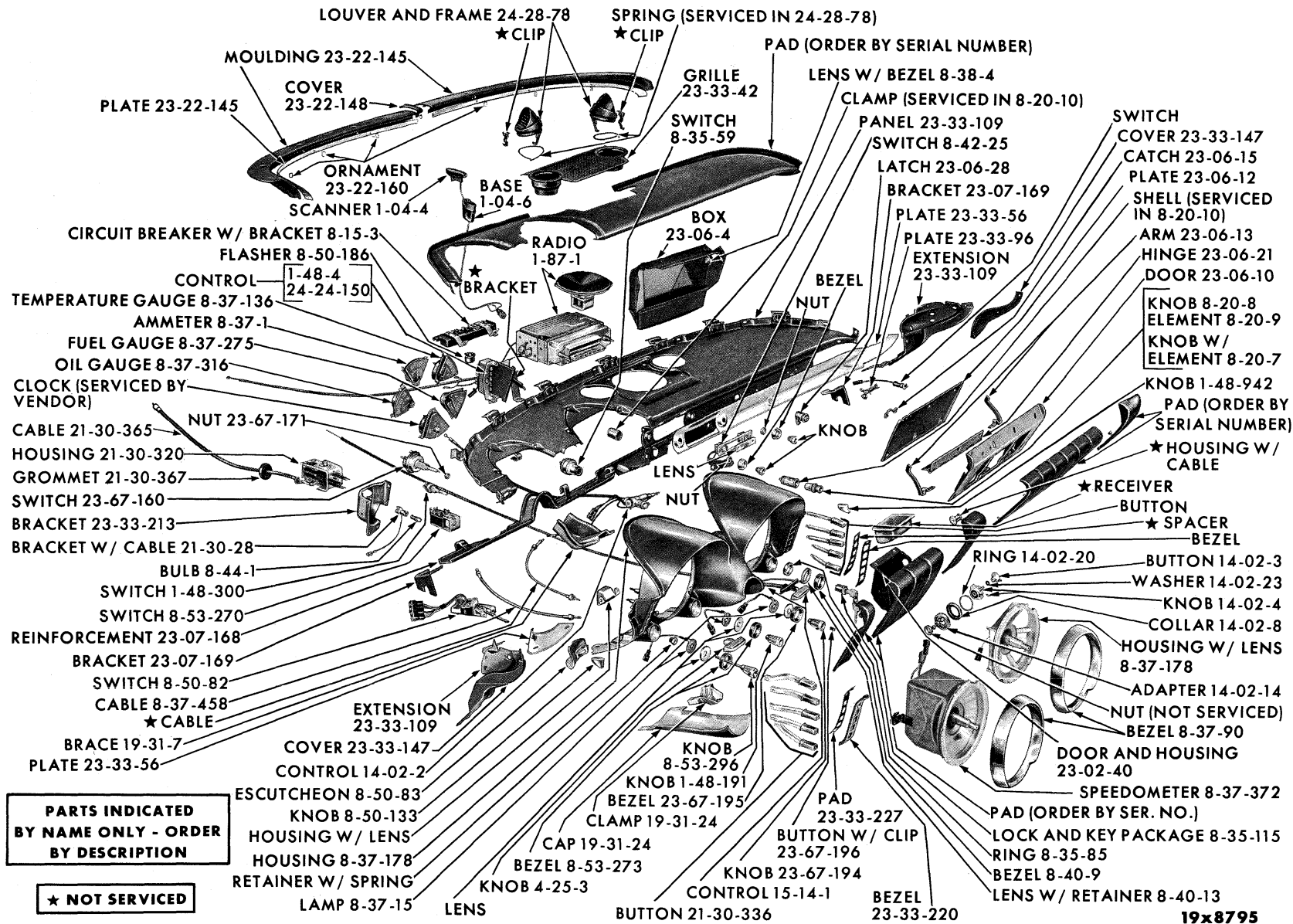

PARTS INDICATED BY NAME ONLY - ORDER BY DESCRIPTION

★ NOT SERVICED

19x8795

INSTRUMENT PANEL - IMPERIAL PY1

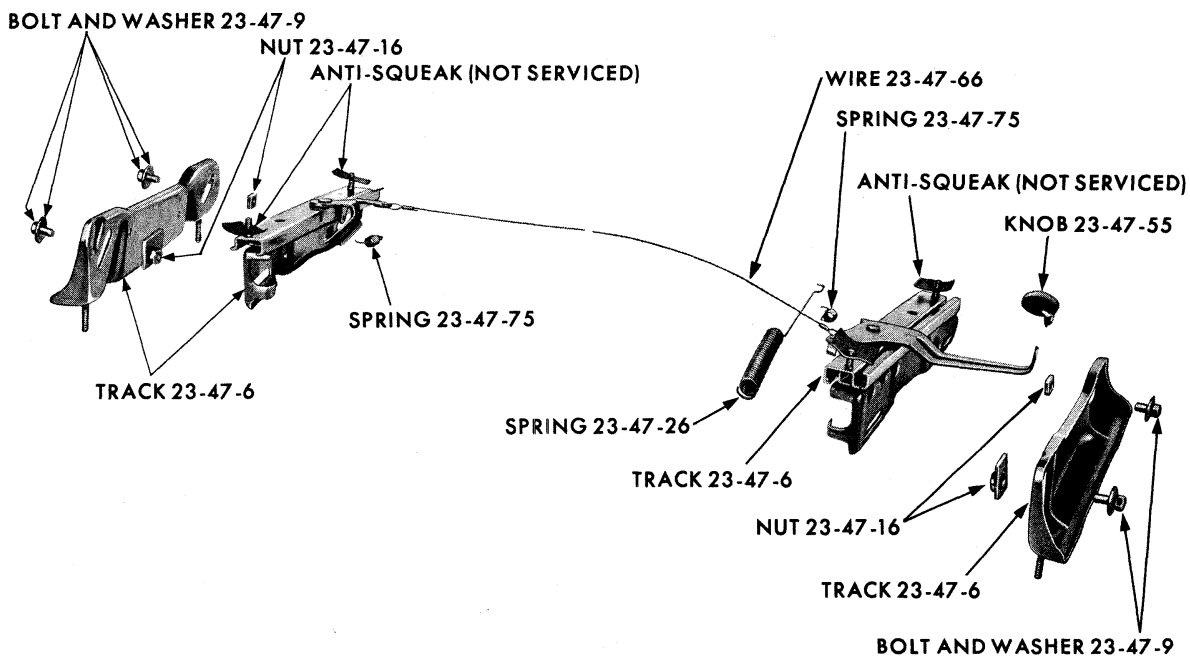

19x8815

MANUAL SEAT GUIDE

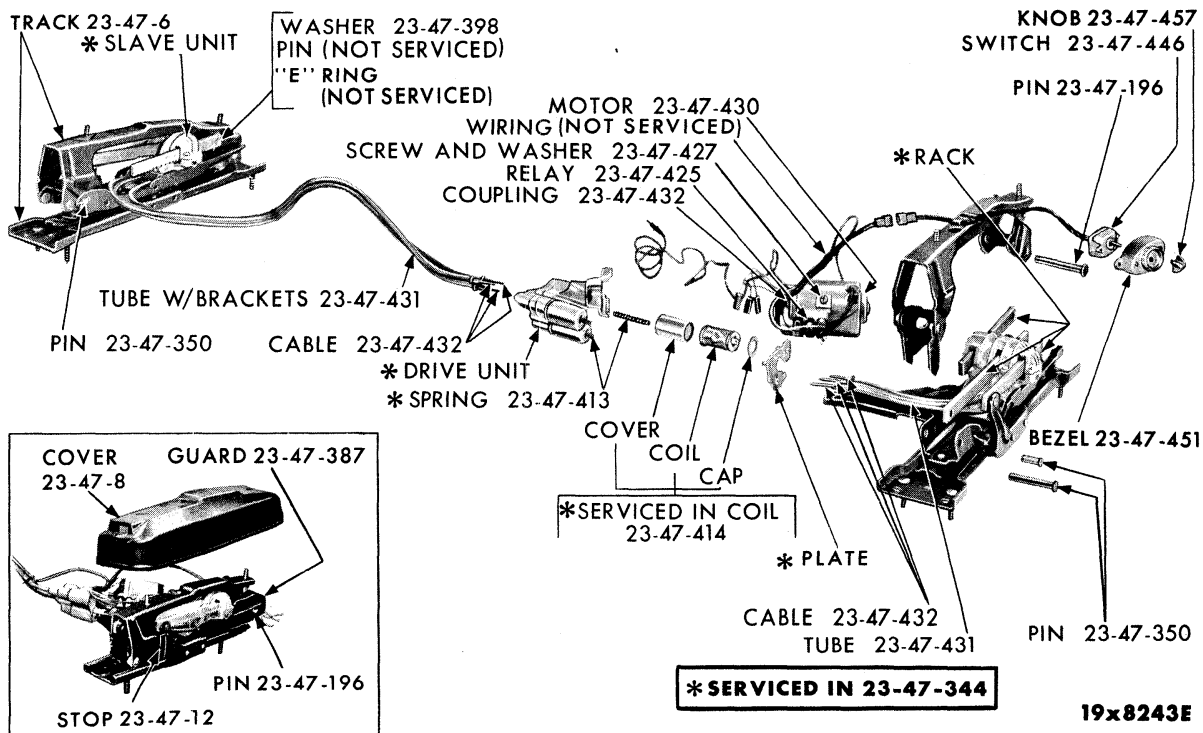

19x8243E

SEAT ADJUSTER - ELECTRIC, 6-WAY

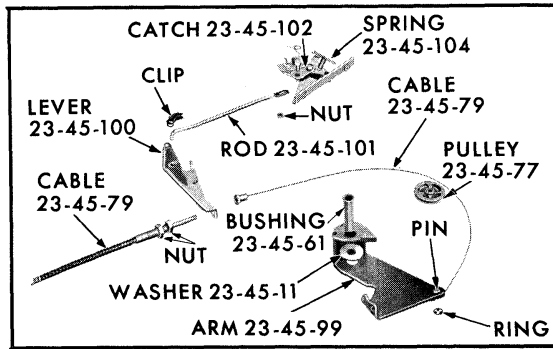

**PARTS INDICATED
 BY NAME ONLY - ORDER
 BY DESCRIPTION**

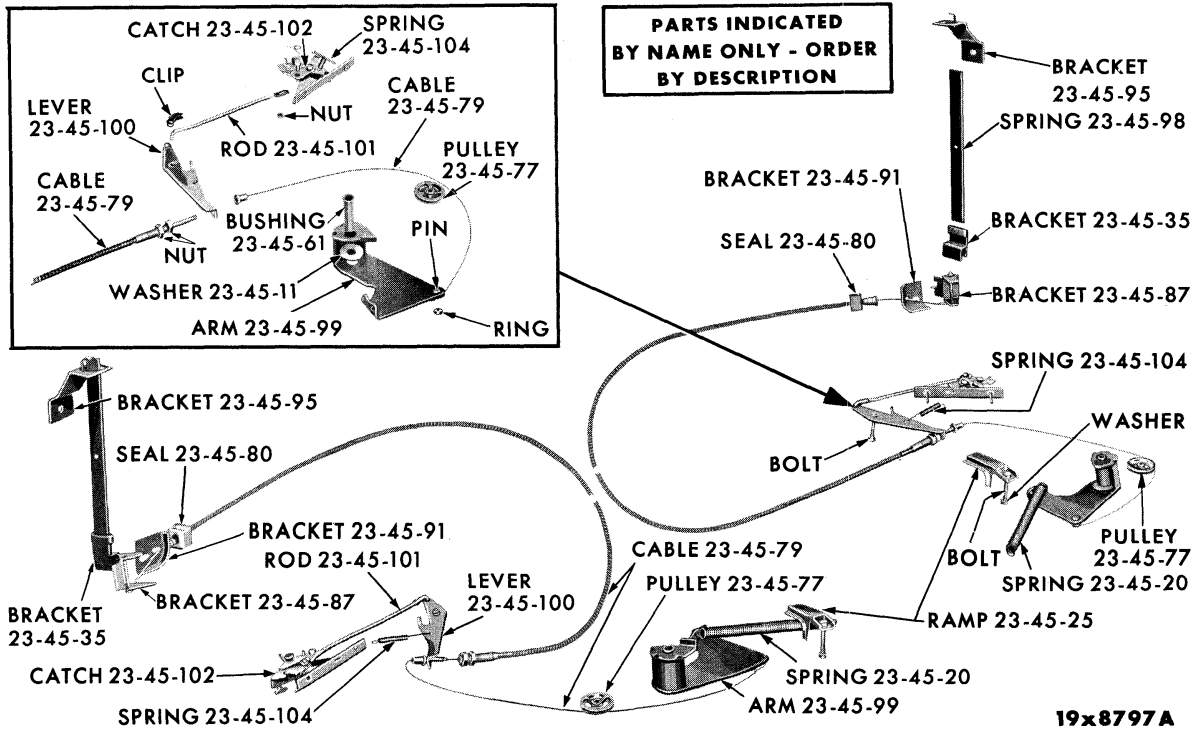

19x8797A

SWIVEL SEAT MECHANISM

NOTES

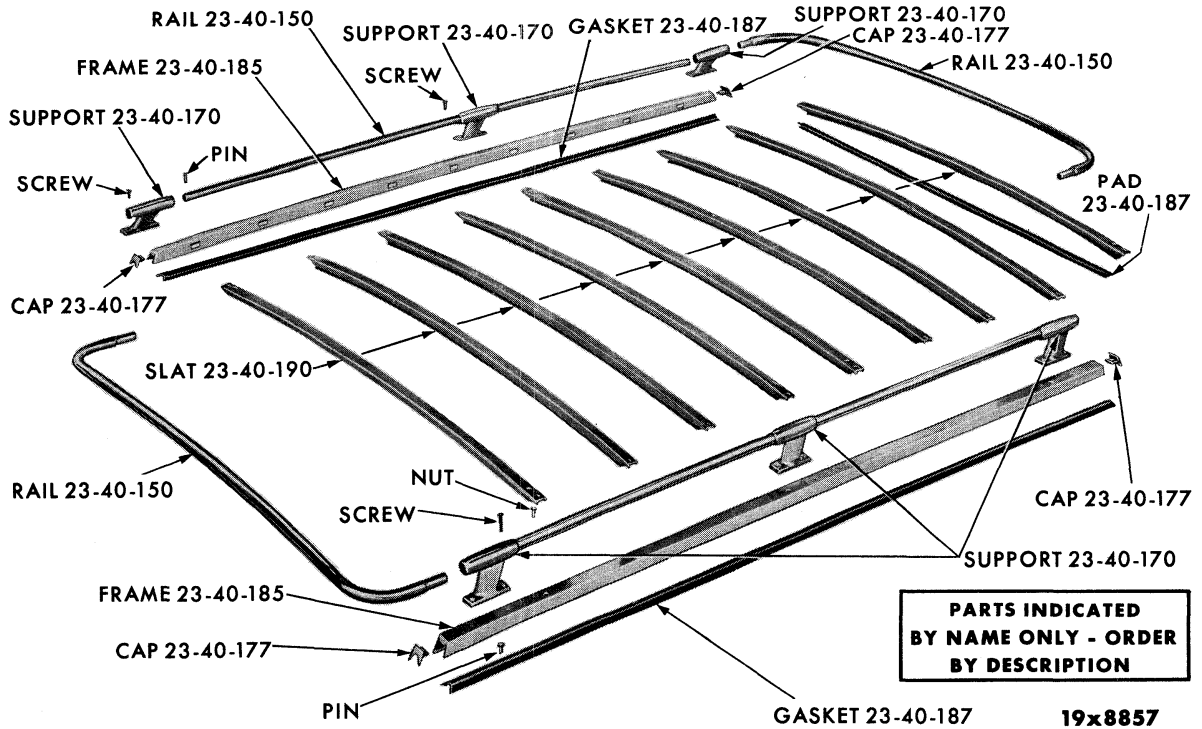

ROOF RACK

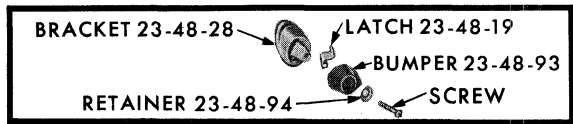

PARTS INDICATED BY NAME ONLY - ORDER BY DESCRIPTION

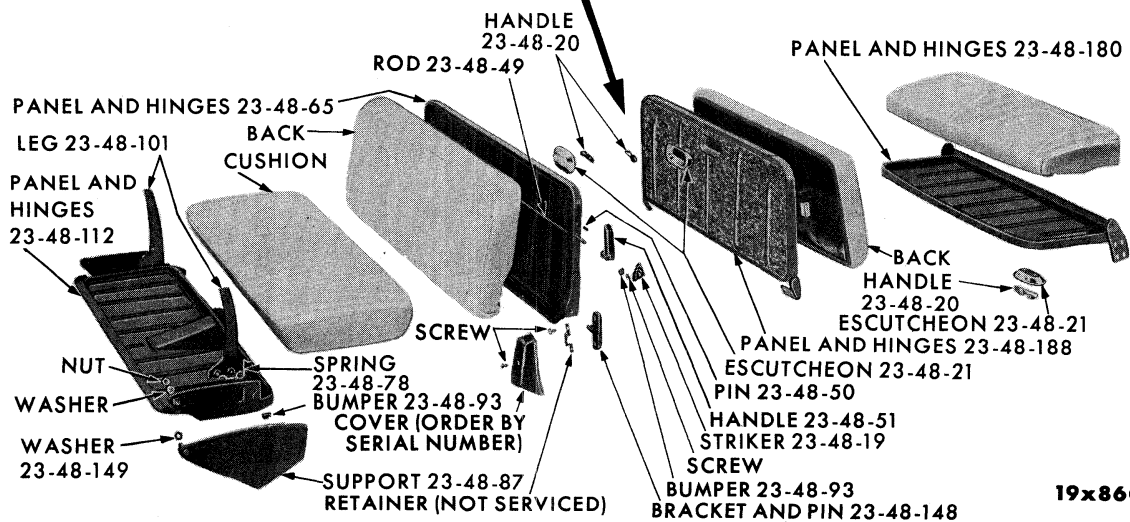

SEATS - SUBURBANS

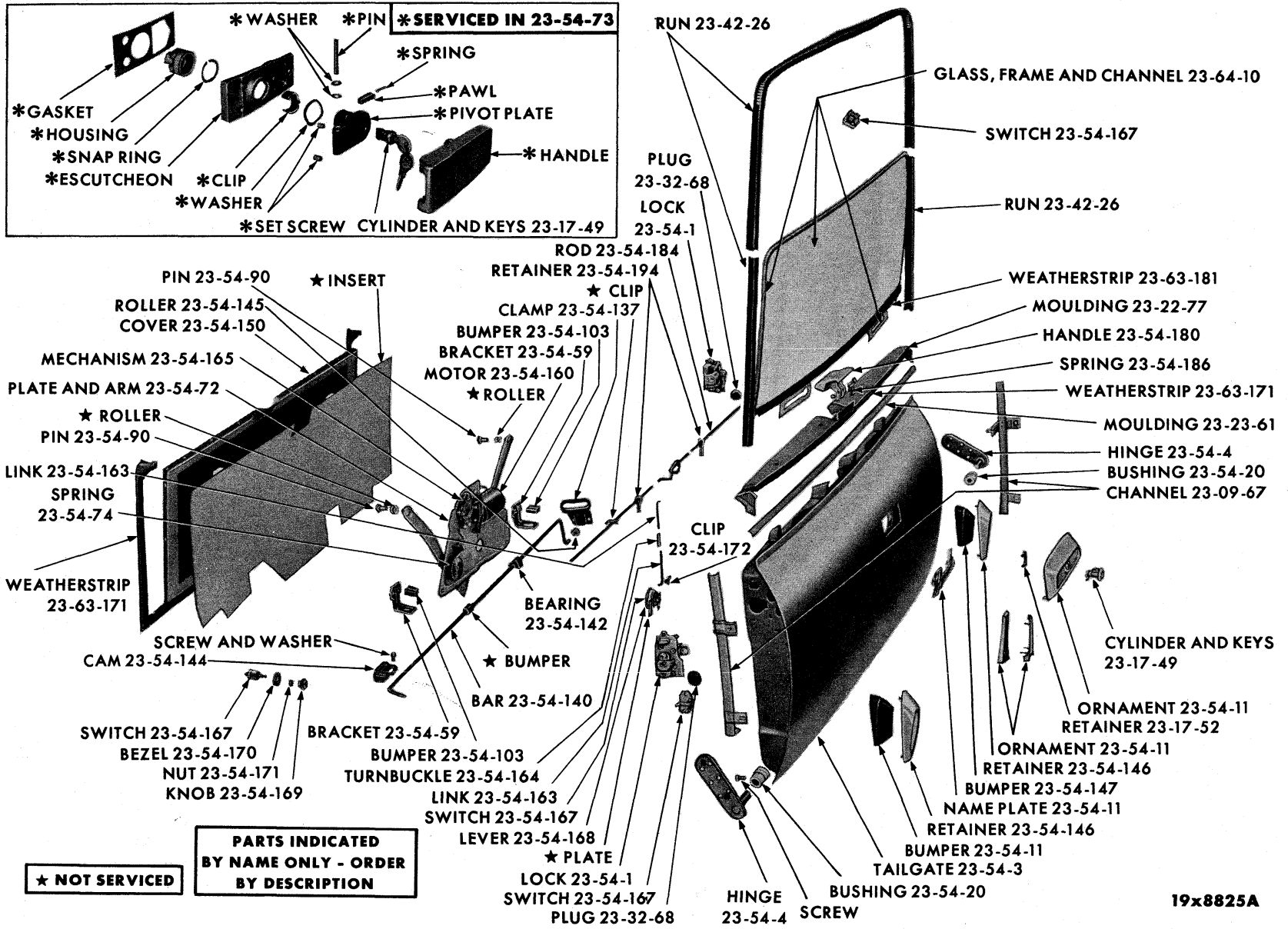

**PARTS INDICATED
BY NAME ONLY - ORDER
BY DESCRIPTION**

★ NOT SERVICED

19x8825A

TAILGATE - SUBURBANS

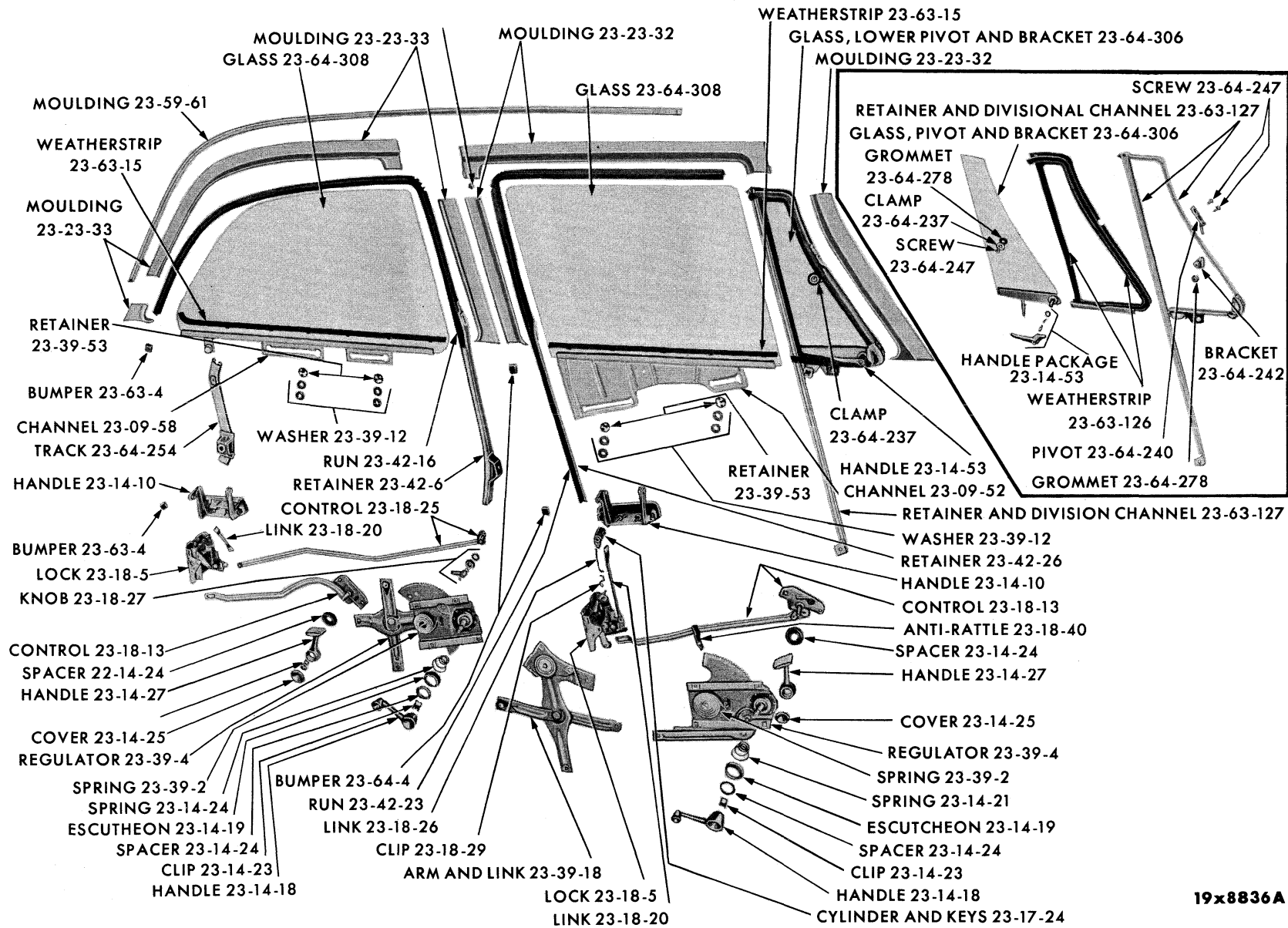

19x8836A

WINDOWS, REGULATORS AND RUNS - PLYMOUTH PP1-2 4 DOOR SEDAN

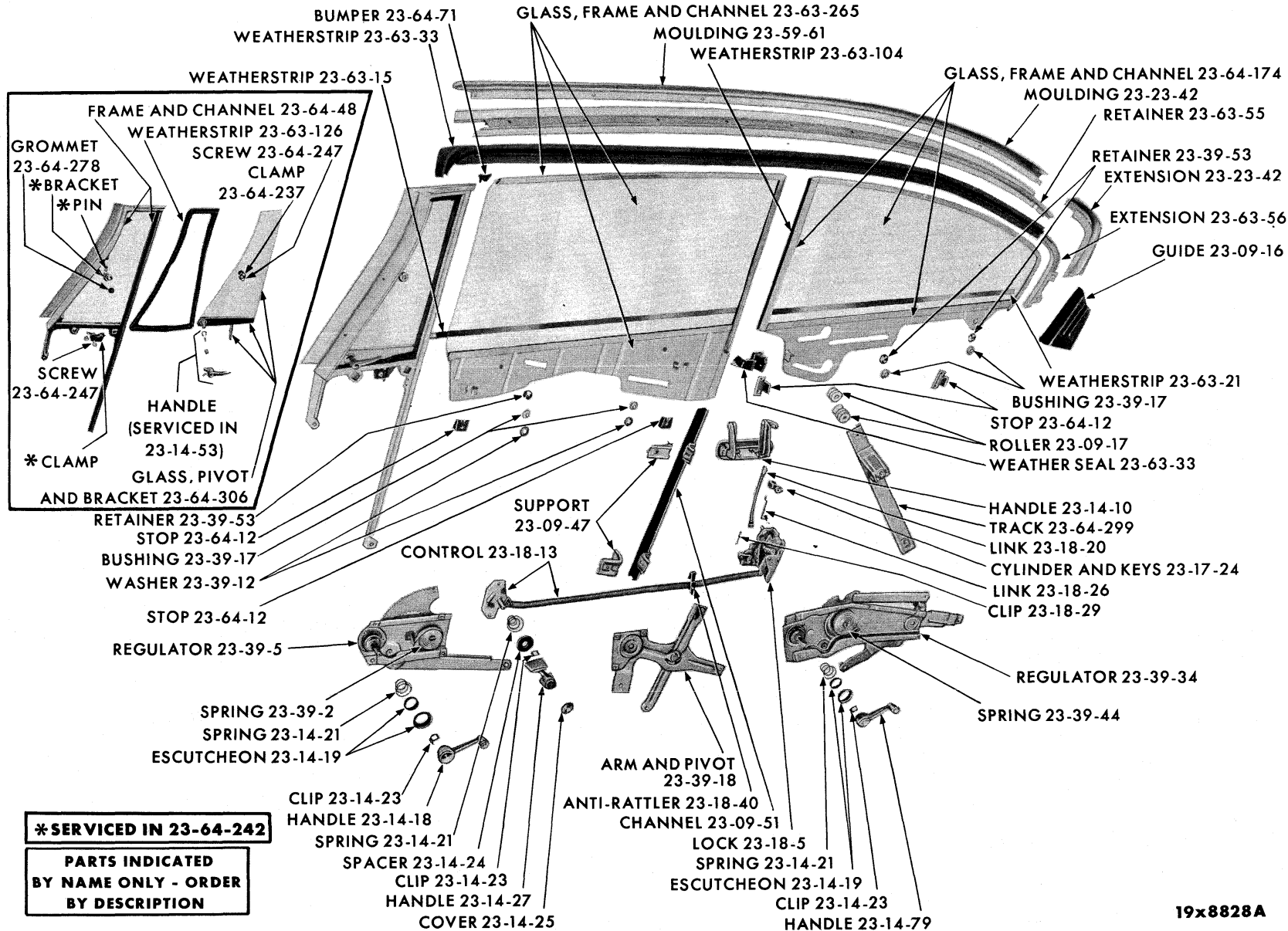

19x8828A

WINDOWS, REGULATORS AND RUNS - PLYMOUTH PP1-2 SPECIAL CLUB COUPE

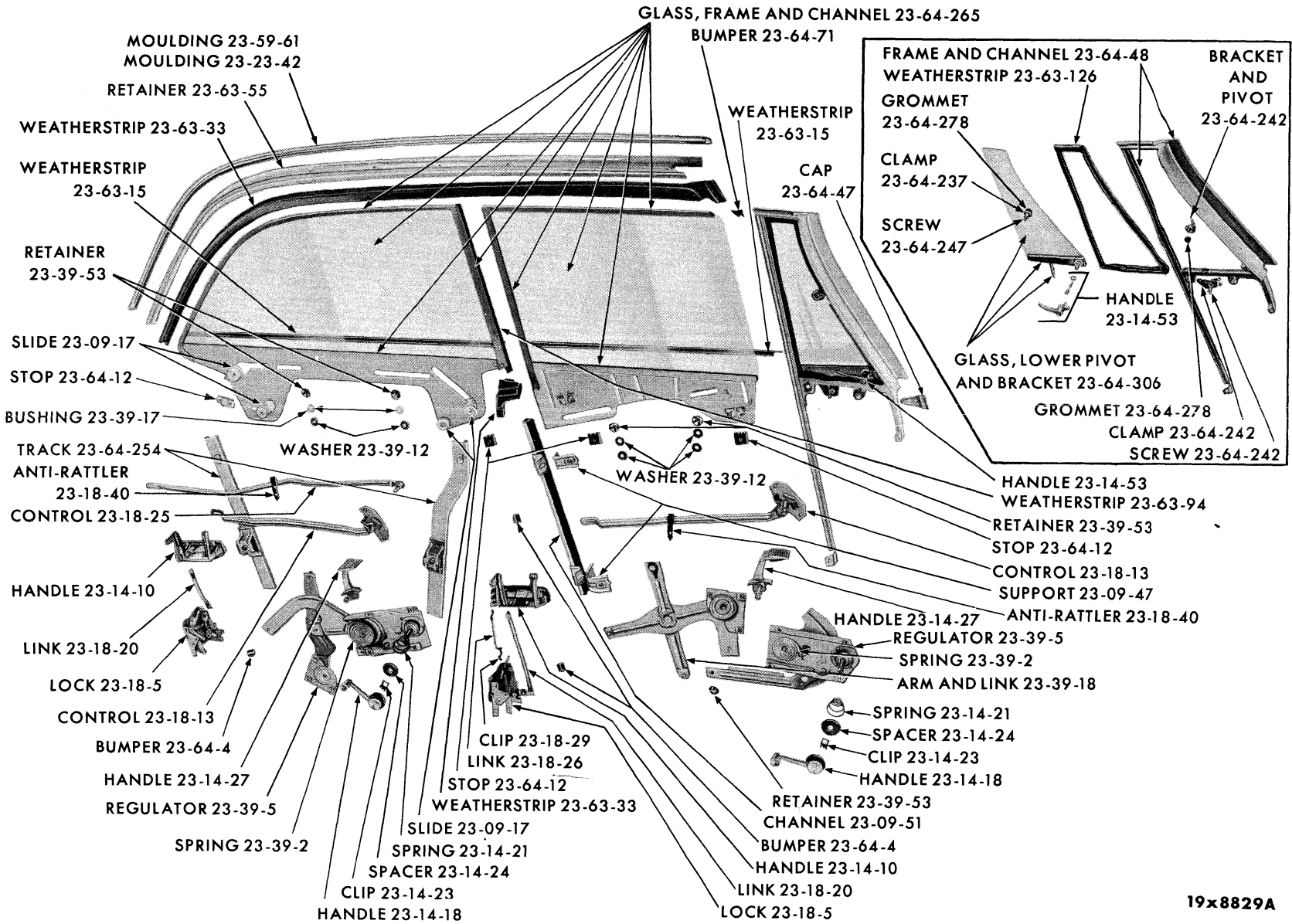

19x8829A

WINDOWS, REGULATORS AND RUNS - DODGE PD1-2-3-4, DESOTO PS1-3 AND CHRYSLER PC1-2-3 SPECIAL 4 DOOR SEDAN

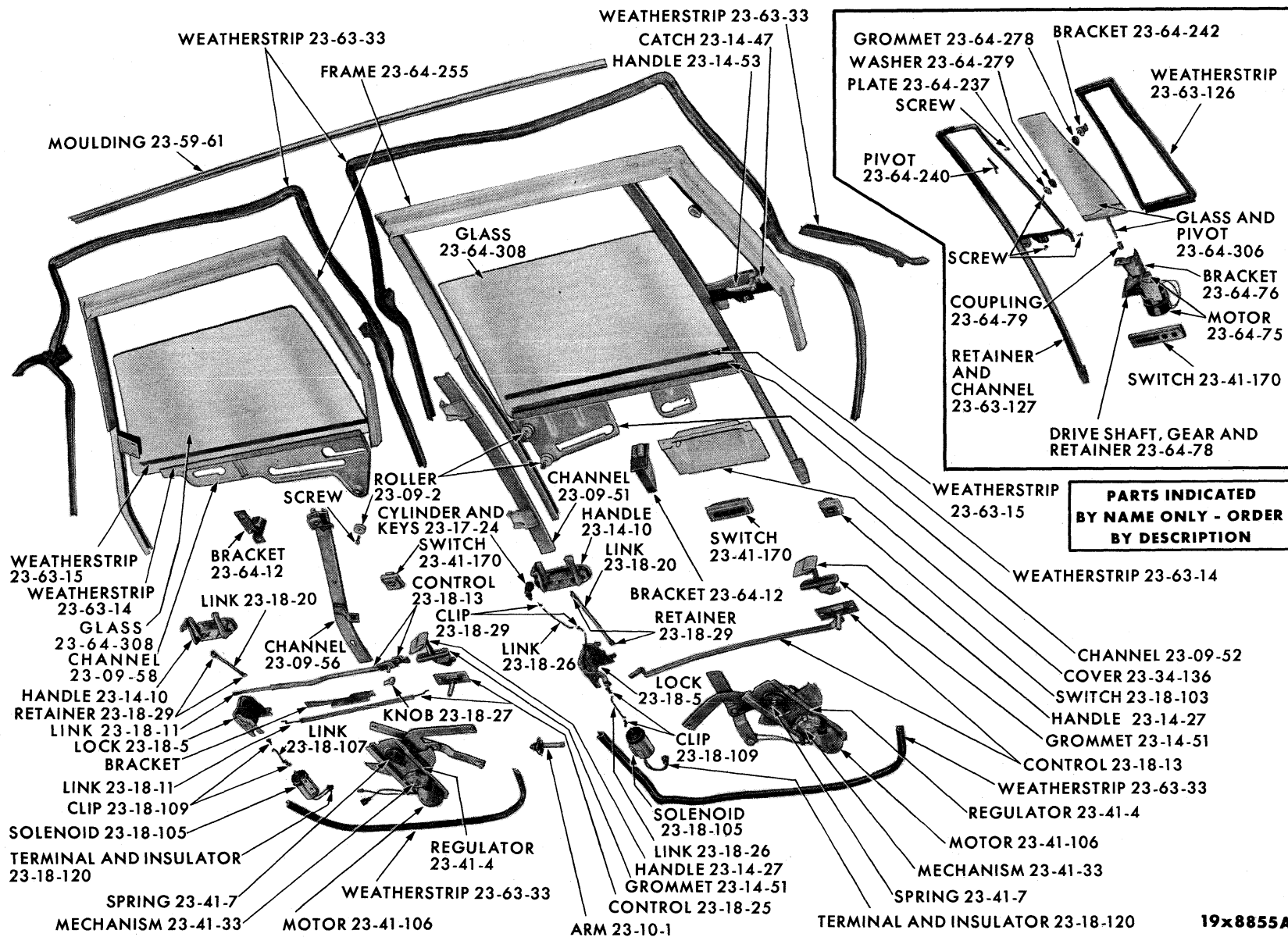

**PARTS INDICATED
BY NAME ONLY - ORDER
BY DESCRIPTION**

19x8855A

WINDOWS, REGULATORS AND RUNS - IMPERIAL PY1 4 DOOR SEDAN

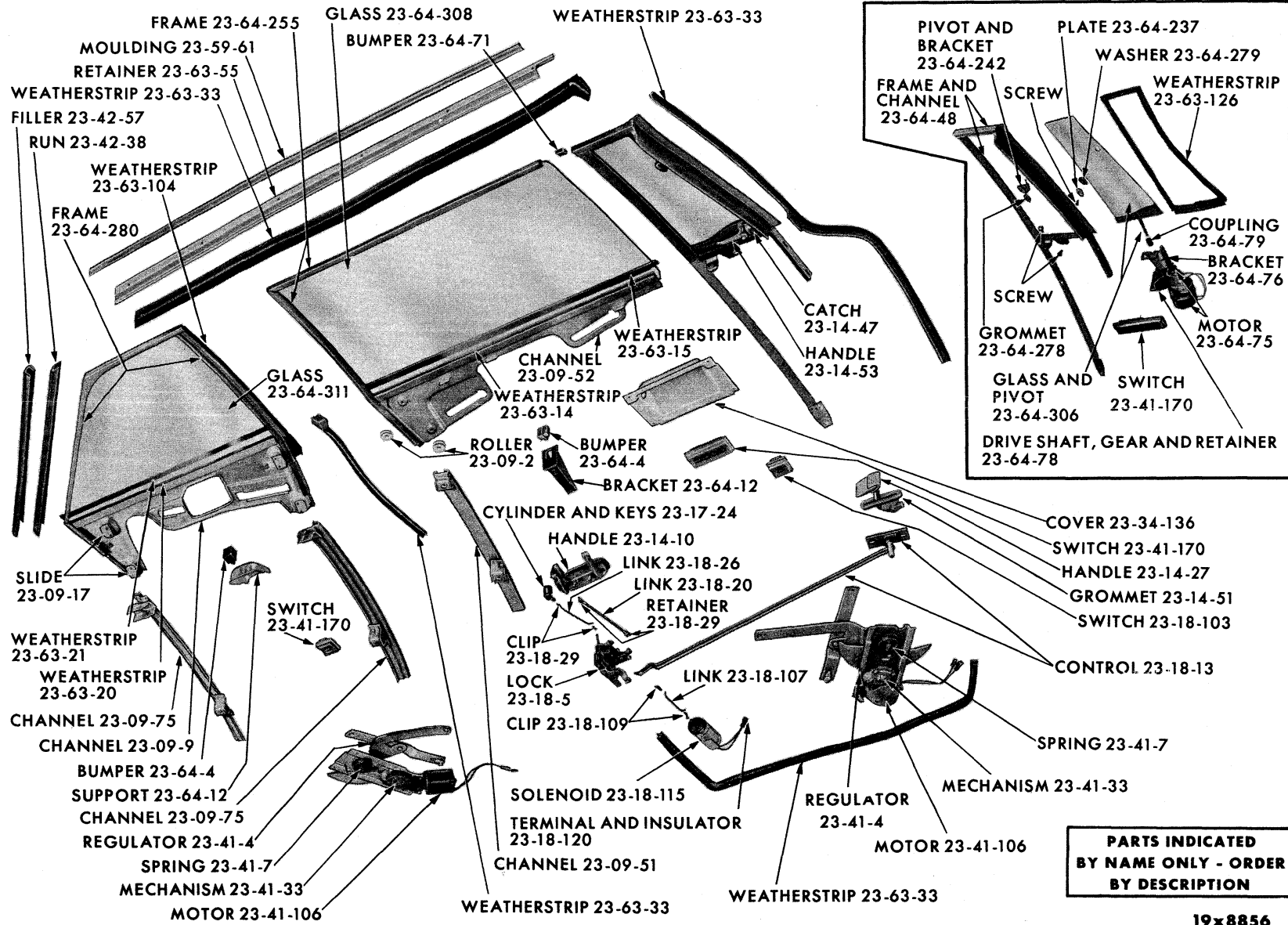

**PARTS INDICATED
BY NAME ONLY - ORDER
BY DESCRIPTION**

19x8856

WINDOWS, REGULATORS AND RUNS - IMPERIAL PY1 SPECIAL CLUB COUPE

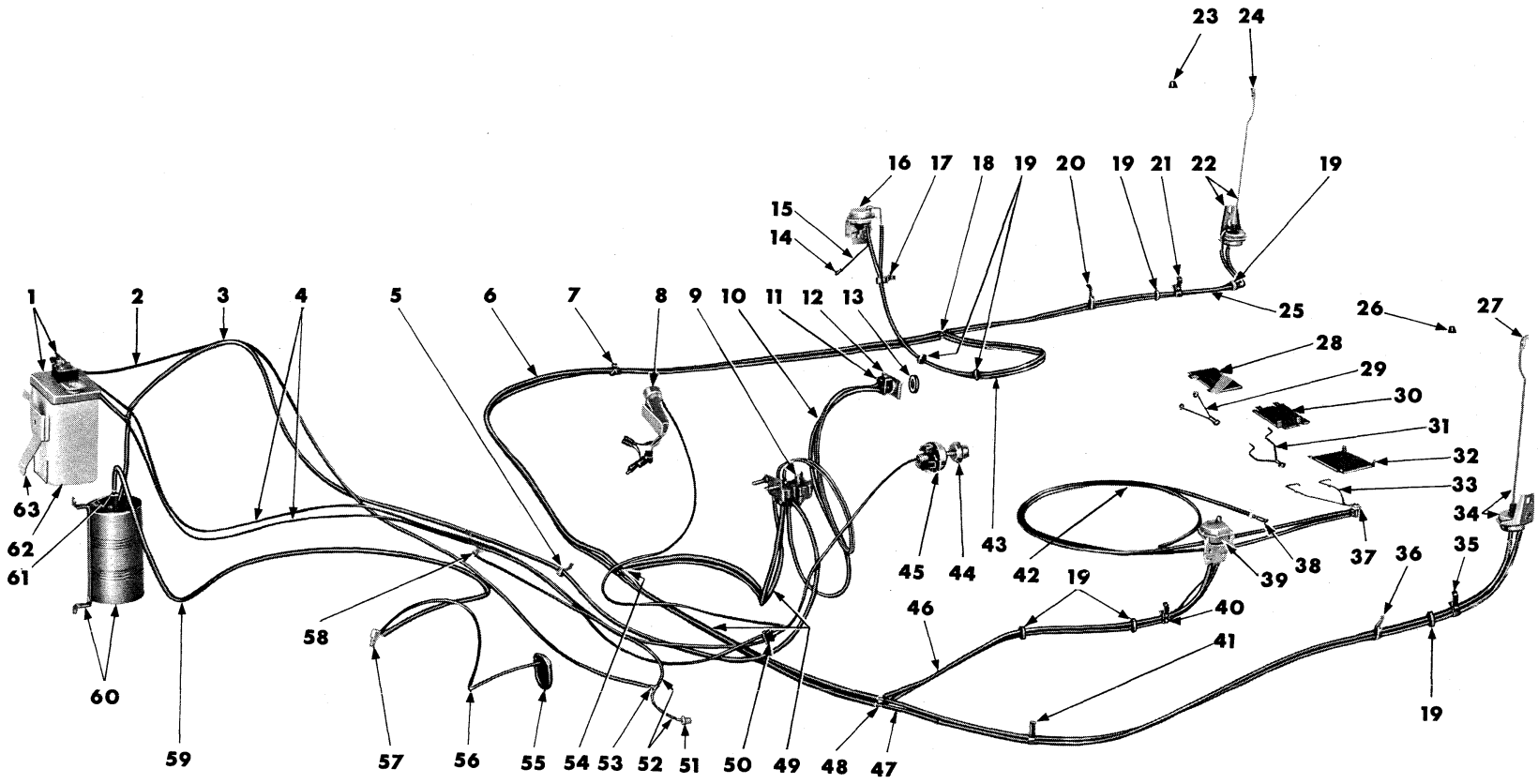

19-8801

SAFE-T-MATIC DOOR LOCK SYSTEM AND PUSH-BUTTON CONTROLLED VACUUM WINDSHIELD WASHER SYSTEM

SAFE-T-MATIC DOOR LOCK SYSTEM AND PUSH-BUTTON CONTROLLED VACUUM WINDSHIELD WASHER SYSTEM

Ref. No.	Name	Part No.	Part Type Code
1	Pump, w/Cover	1-2096 686	1-82-25
2	Hose, Reservoir to Tee	1-2197 650	1-82-44
3	Hose, Tank to Distributor Valve (1/4" I.D. x 96" Long)	1-2097 055	23-13-50
4	Hose, Reservoir to Actuator Inst. Panel	1-2096 623	1-82-44
	Hose, Reservoir to Coord. Switch	1-2096 623	1-82-44
5	Strap		Not Serv.
6	Tube, Floor Pan, Right (3/16" I.D. x 87" Long)	2-1964 204	23-13-10
7	Clamp	★-2165 090	23-13-25
8	Switch, Windshield Washer Coordinator	1-1971 660	1-82-14
9	Valve, Distributor	1-2096 690	23-13-41
10	Tube, Control (or Switch) to Distributor Valve (1/8" I.D. x 32" Long)	1-1964 685	23-13-10
	(5/32" I.D. x 32" Long)	1-1964 641	
11	Control, Instrument Panel (or Switch)	1-2096 487	23-13-31
12	Bezel (Round, use without pad)	1-2096 488	23-13-35
	(Oblong, use with pad)	1-2096 489	
13	Nut, Control and Bezel Mounting	1-2096 490	23-13-36
14	Clip, Rod End to Door Lock, Front	1-6000 798-9	23-13-17
15	Rod, Front Door Power Unit to Door Lock (Plymouth and Dodge)	2-1963 671	23-13-20
	(DeSoto and Chrysler)	2-1963 673	
16	Unit, Front Door Power (Right)	1963 196	23-13-6
17	Clamp		Not Serv.
18	Tee, Tube (3/16" x 3/16" x 1/4")	★-1964 610	23-13-13
19	Grommet (to fit 3/8" hole)	★-1964 012	23-13-11
	(to fit 39/64" hole)	★-1964 013	
	(to fit 15/16" hole)	★-1963 094	
	(with dab of green paint)	★-1963 095	
	(with dab of white paint)	★-1963 096	
	(with dab of red paint)	★-1963 097	
20	Clamp		Not Serv.
21	Clamp	★-2165 090	23-13-25
22	Unit, Rear Door Power, w/Rod (Right)	1-1964 918	23-13-6
23	Knob, Rear Door Lock Locking Control	1-1964 394	23-13-37
24	Clip, Rod End to Door Lock (Rear, Right)	1-6008 144	23-13-17
25	Tube, Rear Door (3/16" I.D. x 120" Long)	2-1964 206	23-13-10
26	Knob, Rear Door Lock Locking Control	1-1964 394	23-13-37
27	Clip, Rod End to Door Lock (Rear, Left)	1-6008 145	23-13-17
28	Plate, De-Activator Valve (Plymouth only)(use with swivel seat)		Not Serv.
29	Support, Front Seat De-Activator Valve (Plymouth only)(use with swivel seat)	1-1964 522	23-13-8
30	Plate, De-Activator Valve (Plymouth only)(use with Saginaw type seat springs)		Not Serv.
31	Support, Front Seat De-Activator Valve (Ply. only)(use with L.A. Young type seat Springs)	1-1964 425	23-13-8
32	Plate, De-Activator Valve (Ply. only)(use with L.A. Young type seat springs)		Not Serv.
33	Support, Front Seat De-Activator Valve (Ply. only)(use with Saginaw type seat Springs)	1-1964 504	23-13-8
34	Unit, Rear Door Power, w/Rod (except Dodge 3-Seat Suburbans, Left)	1-1964 919	23-13-6
	(Dodge 3-Seat Suburbans, Left)	1-2165 778	
35	Clamp	★-2165 090	23-13-25
36	Clamp		Not Serv.
37	Valve, Front Seat De-Activator (Plymouth only)	1-1964 190	23-13-7
38	Connector, Tube (Plymouth only - 1/8" x 1/8")	1-1964 881	23-13-13
39	Unit, Front Door Power (Left)	1963 197	23-13-6
40	Clamp	★-2165 090	23-13-25
41	Clamp		Not Serv.
42	Tube, Distributor Valve to De-Activator Valve (Ply. only-1/8" I.D. x 126" Long)	2-1964 708	23-13-10
43	Tube, Front Door (3/16" I.D. x 79" Long)	2-1964 203	23-13-10
44	Knob		23-67-194
45	Switch		1-82-41
46	Tube, Front Door (3/16" I.D. x 79" Long)	2-1964 203	23-13-10
47	Tube, Rear Door (3/16" I.D. x 120" Long)	2-1964 206	23-13-10
48	Tee, Tube (3/16" x 3/16" x 1/4")	★-1964 610	23-13-13
49	Tube, Distributor Valve to Main Tee (1/4" I.D. x 29" Long)	2-1964 573	23-13-10
50	Grommet	1-2097 815	1-82-28
51	Nozzle, Windshield Washer (PY1)	2-1887 319	1-82-6
	(except PY1)	2-1887 321	1-82-6
52	Tube, Floor Pan (Left, 1/4" I.D. x 29" Long)	2-1964 573	
53	Tee, Windshield Washer Hose	1-1523 160	1-82-8
	Hose, Tee to Nozzle, Right	1-2096 623	1-82-44
	Hose, Tee to Nozzle, Left	1-2096 623	1-82-44
54	Tee, Tube (1/4" x 1/4" x 1/4")	2-1964 609	23-13-13
55	Grommet		Not Serv.
56	Hose, Windshield Washer	1-2096 623	1-82-44
57	Connector, Vacuum Control	1-2121 942	1-82-48
58	Nozzle, Windshield Washer (PY1)	2-1887 319	1-82-6
	(except PY1)	2-1887 321	1-82-6
59	Hose, Tank to Manifold Tee (1/4" I.D. x 76" Long)	1-1887 477	23-13-50 & 1-82-44
60	Tank, w/Bracket	1-2096 822	23-13-45
61	Tee, Tank Hose (5/16" x 5/16" x 5/16")	1-2097 209	23-13-51
62	Reservoir	1-2096 688	1-82-4
63	Bracket, Reservoir Mounting		Not Serv.

PARTS INDICATED BY NAME ONLY - ORDER BY DESCRIPTION

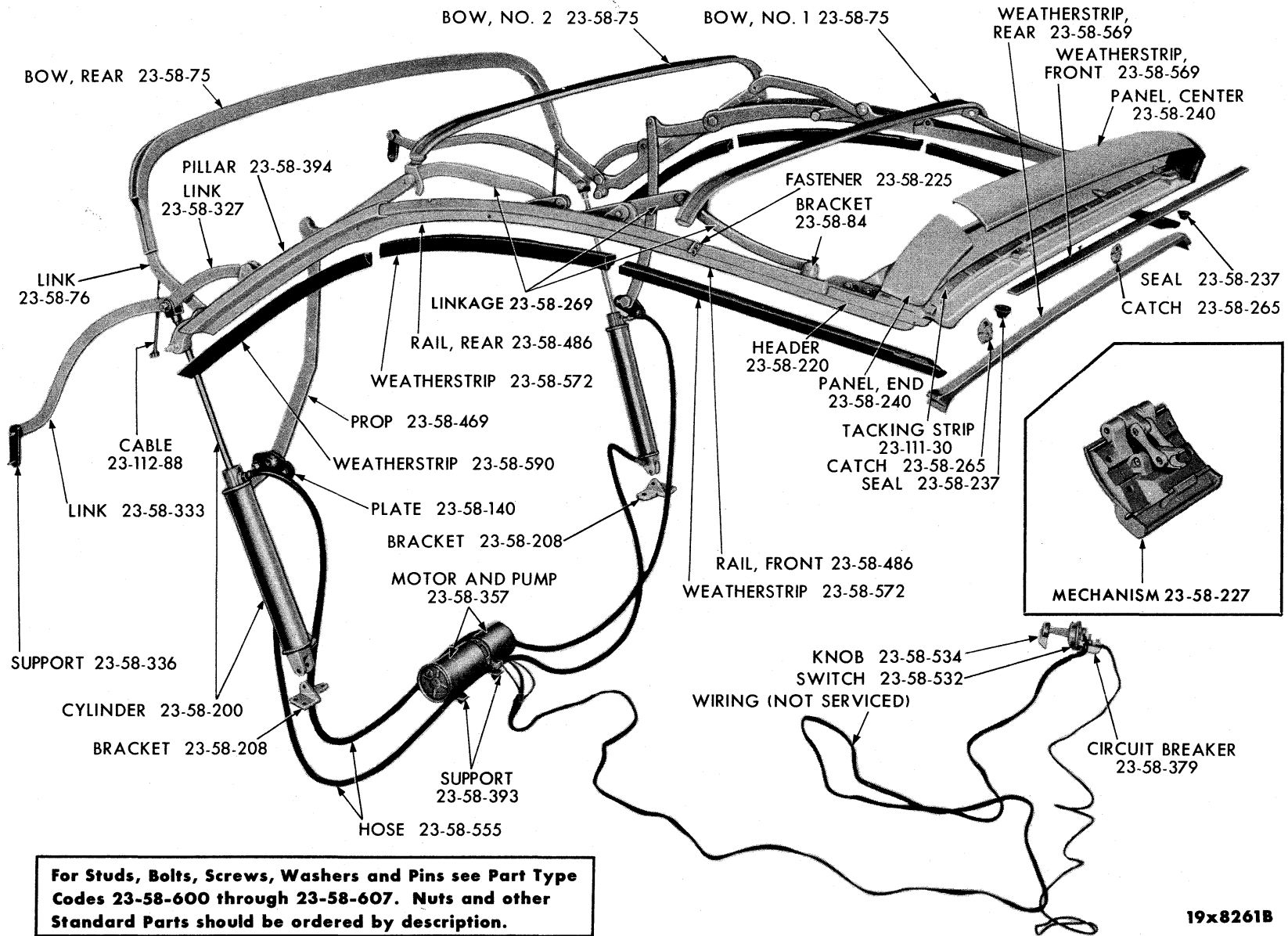

For Studs, Bolts, Screws, Washers and Pins see Part Type Codes 23-58-600 through 23-58-607. Nuts and other Standard Parts should be ordered by description.

19x8261B

CONVERTIBLE COUPE FOLDING TOP - EXCEPT IMPERIAL PY1

PARTS INDICATED BY NAME ONLY - ORDER BY DESCRIPTION

ORDER BY SERIAL NUMBER

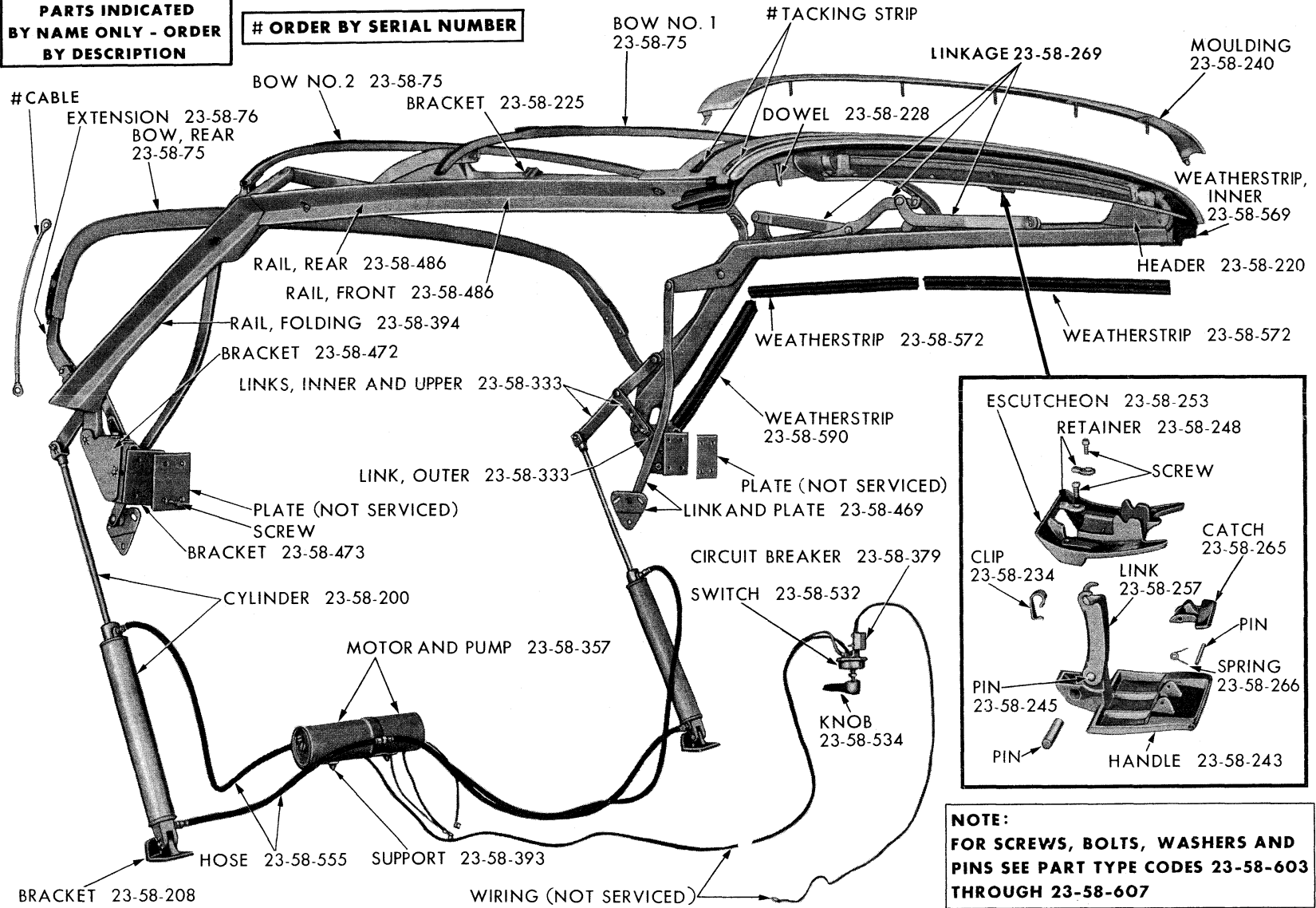

NOTE:
FOR SCREWS, BOLTS, WASHERS AND PINS SEE PART TYPE CODES 23-58-603 THROUGH 23-58-607

19x8248A

CONVERTIBLE COUPE FOLDING TOP - IMPERIAL PY1

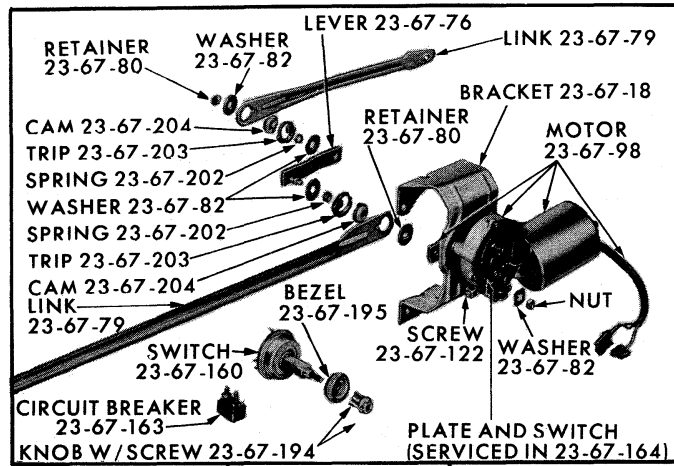

VARIABLE SPEED

**PARTS INDICATED
BY NAME ONLY - ORDER
BY DESCRIPTION**

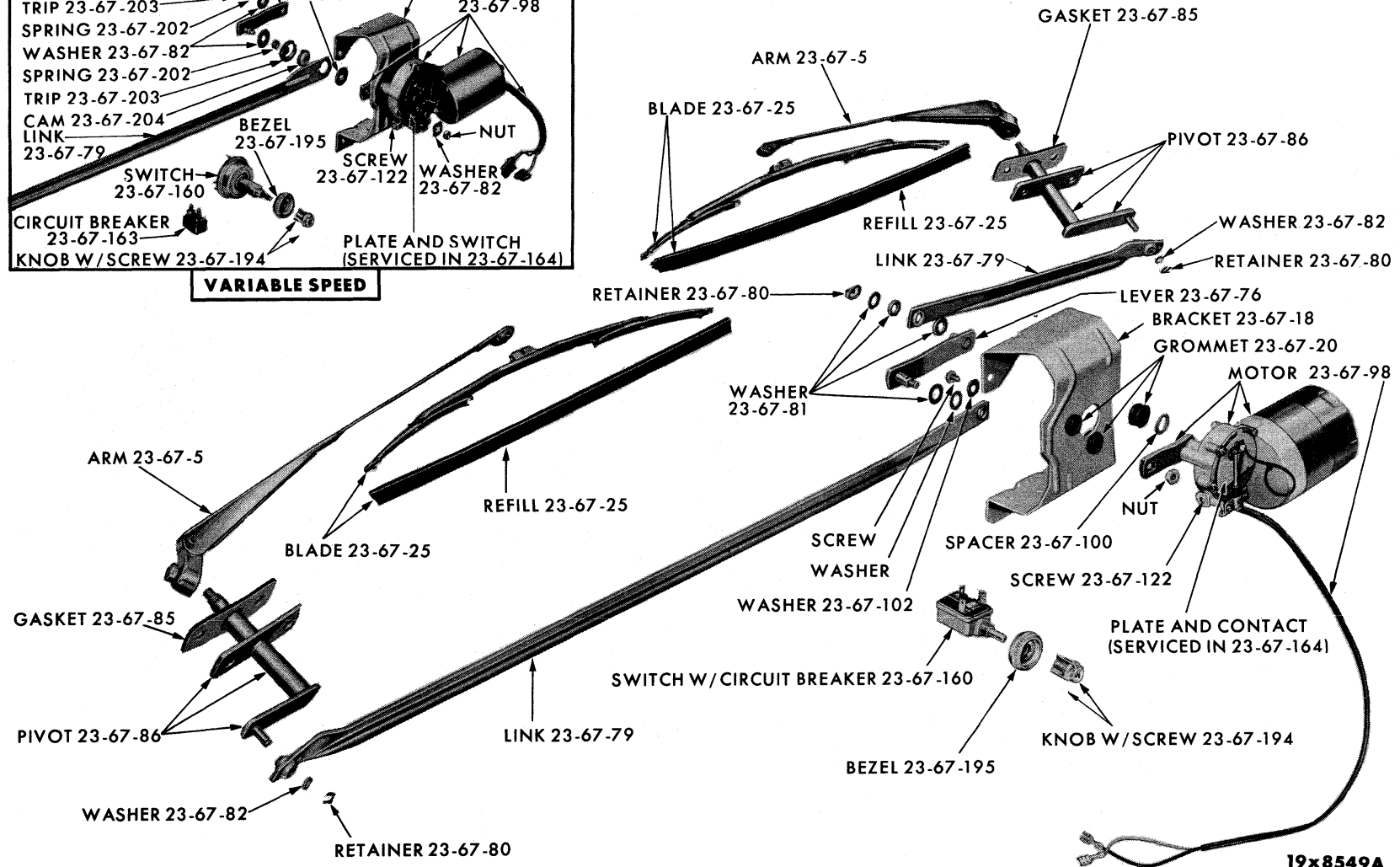

19x8549A

WINDSHIELD WIPER - EXCEPT IMPERIAL PY1

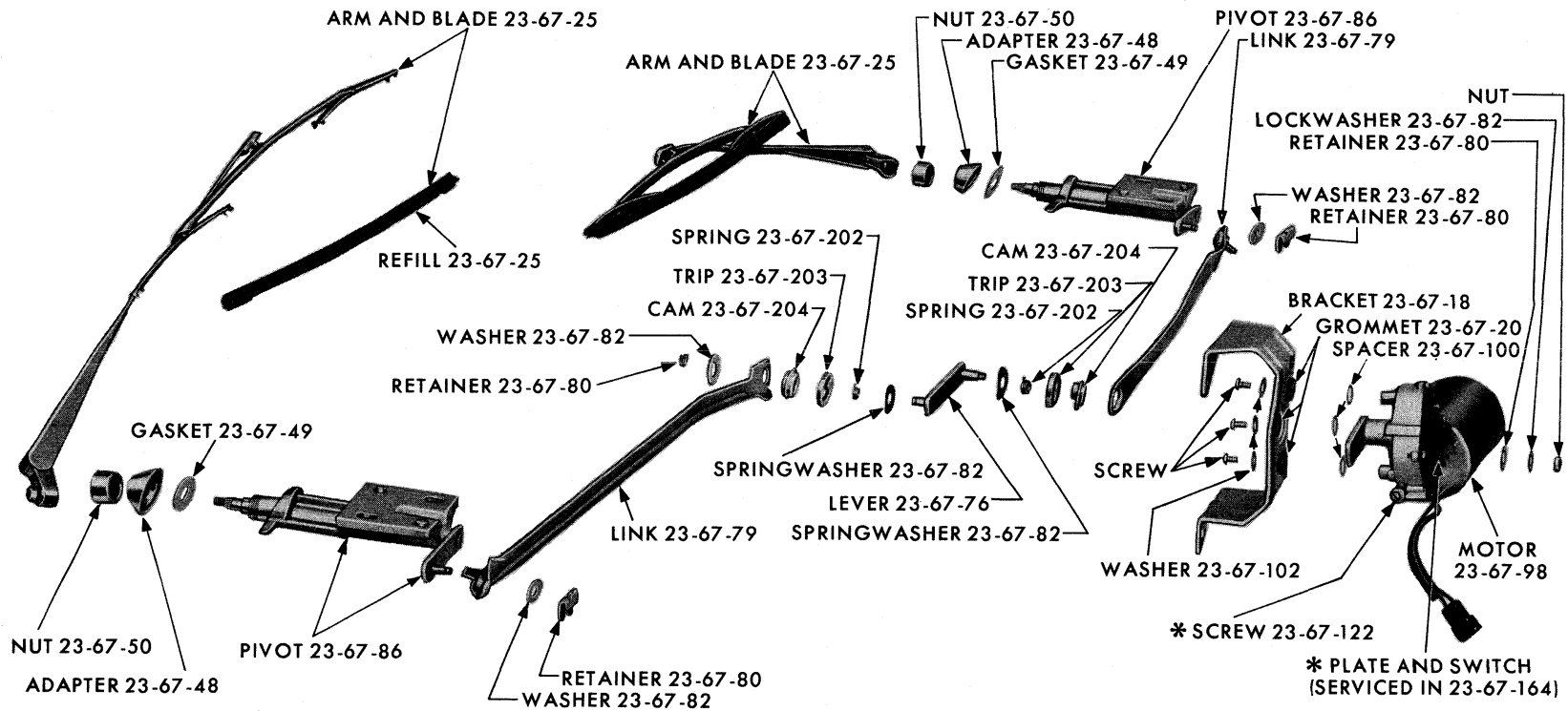

*** ALSO SERVICED IN 23-67-98**

PARTS INDICATED BY NAME ONLY ARE STANDARD PARTS — ORDER BY DESCRIPTION.

WINDSHIELD WIPER - IMPERIAL PY1

19x8542B

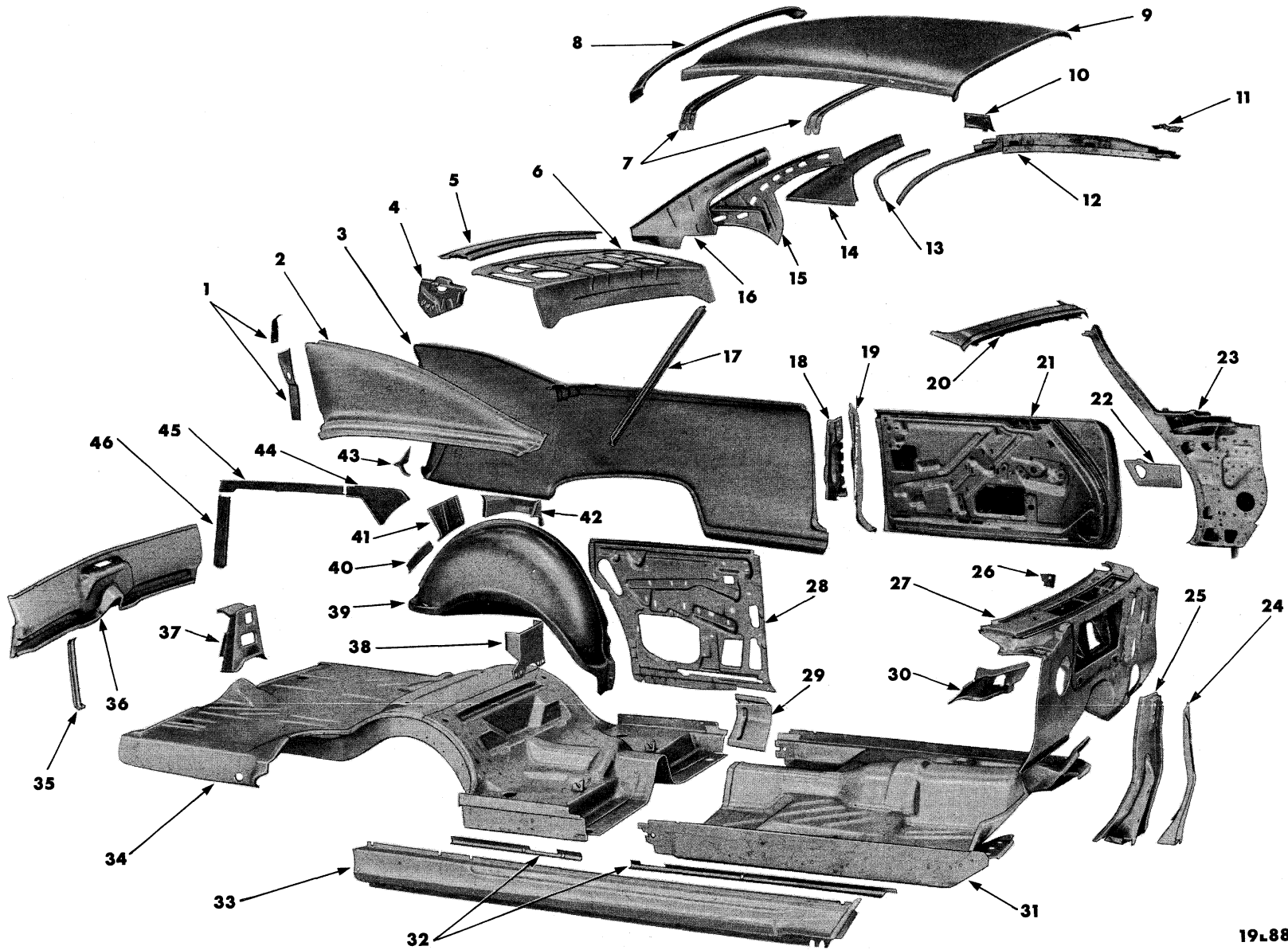

19.8881

BODY - PLYMOUTH PP1-2 SPECIAL CLUB COUPE

BODY - PLYMOUTH PP1-2 SPECIAL CLUB COUPE

Ref. No.	Name	Part Type Code	Ref. No.	Name	Part Type Code
1	Reinforcement	8-55-23	24	Support Brace	Not Serviced
2	Panel	23-34-233	25	Brace (Serviced in 23-34-80) . . .	
3	Panel	23-34-235	26	Bracket	Not Serviced
4	Support	23-19-82	27	Dash Panel (Serviced in 23-34-80)	
5	Panel	23-34-166	28	Panel	23-34-234
6	Shelf Panel	Not Serviced	29	Tie Plate	Not Serviced
7	Bow		30	Brace (Serviced in 23-34-80) . . .	
8	Frame	23-64-66	31	Front Floor Pan	
9	Roof Panel	23-34-301	32	Reinforcement	Not Serviced
10	Extension	23-64-68	33	Panel	23-51-5
11	Reinforcement	Not Serviced	34	Rear Floor Pan (Complete)	23-32-48
12	Rail	23-40-85	35	Support	Not Serviced
13	Trough	23-59-56	36	Panel	23-34-167
14	Extension	23-34-280	37	Support	23-19-74
15	Gusset	23-64-70	38	Bracket	Not Serviced
16	Brace	23-40-97	39	Panel	23-34-27
17	Brace	Not Serviced	40	Support	Not Serviced
18	Reinforcement (Serviced in 23-36-53).		41	Support	23-19-82
19	Pillar	23-36-53	42	End Panel (Serviced in 23-34-354)	
20	Header & Reinforcement	23-34-354	43	Support	23-34-285
21	Door Shell	23-11-1	44	Support	Not Serviced
22	Bracket (Serviced in 23-34-80) . . .		45	Reinforcement	23-34-177
23	Cowl Side Panel	23-34-80	46	Brace	Not Serviced

PARTS INDICATED BY NAME ONLY - ORDER BY DESCRIPTION

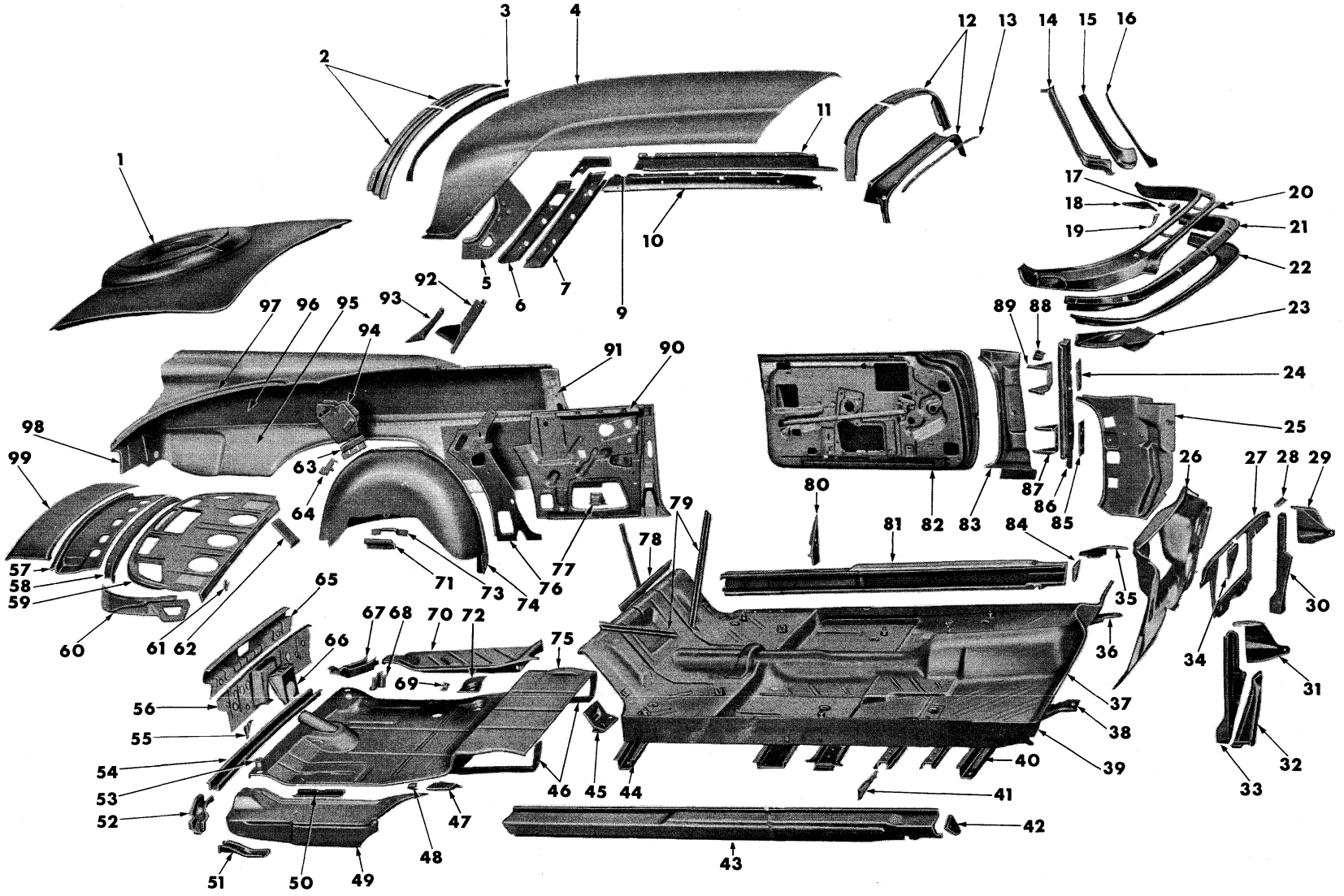

19L8385A

BODY - IMPERIAL PY1 SPECIAL CLUB COUPE

BODY - IMPERIAL PY1 SPECIAL CLUB COUPE

Ref. No.	Name	Part Type Code	Ref. No.	Name	Part Type Code
1	Deck Lid	23-19-8	51	Fuel Tank Rear Floor Pan Reinforcement Extension	Not Serviced
2	Rear Window Opening Upper Frame Reinforcement	23-64-67	52	No. 6 Body Bolt Floor Pan Reinforcement Extension	Not Serviced
3	Rear Window Opening Upper Frame	23-64-66	53	No. 6 Body Bolt Reinforcement to Floor Pan Spacer	23-05-36
4	Roof Panel	23-34-301	54	No. 6 Body Bolt Floor Pan Reinforcement	Not Serviced
5	Rear Window Side Frame	23-64-66	55	Deck Opening Lower Panel Drain Trough Support	Not Serviced
6	Roof Side Rear Outer Rail	23-40-85	56	Deck Opening Lower Panel Reinforcement	23-34-179
7	Roof Side Rear Inner Rail	23-40-85	57	Deck Opening Upper Panel Reinforcement (Serviced in 23-34-166)	
8	Roof Side Inner Front Rail to Roof Side Rear Rail Gusset	Not Serviced	58	Belt Center Bar (Serviced in 23-34-166)	
9	Panel, Roof	23-34-301	59	Shelf Panel	Not Serviced
10	Roof Side Rail	23-40-85	60	Belt Side Bar	23-51-41
11	Roof Side Rail	23-40-85	61	Rear Seat Back Hanger	Not Serviced
12	Windshield Opening Upper Frame (Serviced in 23-34-80)		62	Shelf Panel to Wheelhouse Gusset	Not Serviced
13	Windshield Header Trim Retainer (Serviced in 23-34-80)		63	Deck Lid Hinge Support to Wheelhouse Bracket	Not Serviced
14	Front Hinge Pillar Extension (Serviced in 23-34-80)		64	Wheelhouse Jack Stowage Bracket	Not Serviced
15	Windshield Opening Side Frame (Serviced in 23-34-80)		65	Deck Opening Lower Panel	23-34-167
16	Cowl Top Panel Extension (Serviced in 23-34-80)		66	Deck Opening Lower Panel Lock Support	23-19-74
17	Dash Panel Brake Bellow Reinforcement Assy.	Not Serviced	67	No. 6 Body Bolt Floor Pan Reinforcement	Not Serviced
18	Dash Panel Hood Support to Front Pillar (Serviced in 23-34-80)		68	Rear Floor Pan Jack Stowage Bracket	Not Serviced
19	Front Pillar to Fender Support Upper Bracket	Not Serviced	69	Spare Wheel Anchor Stud Bracket	Not Serviced
20	Cowl Top Panel (Serviced in 23-34-80)		70	Rear Floor Pan Side Extension	23-32-49
21	Windshield Opening Lower Frame (Serviced in 23-34-80)		71	Deck Lid Hinge Support to Wheelhouse Lower Bracket	Not Serviced
22	Windshield Opening Lower Frame Reinforcement (Serviced in 23-34-80)		72	No. 5 Body Bolt Floor Pan Reinforcement	Not Serviced
23	Front Pillar to Cowl Side Filler (Serviced in 23-34-80)		73	Deck Lid Hinge Support to Wheelhouse Bracket	23-19-76
24	Front Pillar Door Hinge Tapping Plate	23-15-13	74	Wheelhouse Panel Assy.	23-34-27
25	Cowl Side Panel	23-34-80	75	Rear Floor Pan	23-32-48
26	Dash Panel	23-34-110	76	Quarter Inside Panel to Wheelhouse Reinforcement	23-34-249
27	Dash Panel Air Duct Cover	23-34-116	77	Quarter Window Lower Stop Support	23-64-12
28	Cowl Top Panel Hood Seal Support (Serviced in 23-34-80)		78	Shelf Panel to Floor Center Brace Support	Not Serviced
29	Hood Hinge Support and Clinch Nut (Serviced in 23-34-80)		79	Shelf Panel to Floor Brace	Not Serviced
30	Dash Panel No. 1 & 1A Body Bolt Brace and Clinch Nut	23-34-122	80	Quarter Inside Panel to Seat Riser Brace	Not Serviced
31	Hood Hinge Support and Clinch Nut (Serviced in 23-34-80)		81	Body Side Sill Outer Panel	23-51-5
32	Dash Panel No. 1 & 1A Body Bolt Brace and Clinch Nut Reinforcement	23-34-126	82	Door Shell	23-11-1
33	Dash Panel No. 1 & 1A Body Bolt Brace and Clinch Nut	23-34-122	83	Front Pillar, Rear Half (Serviced in 23-34-80)	
34	Windshield Wiper Motor Mounting Reinforcement	23-67-129	84	Body Side Sill Front End Cover and Clinch Nut	Not Serviced
35	Dash Panel Hood Hinge Support to Front Cowl Filler Reinforcement	Not Serviced	85	Front Pillar Door Hinge Tapping Plate	23-15-13
36	No. 1 to No. 2 Body Bolt Strainer	Not Serviced	86	Front Pillar Front Half (Serviced in 23-34-80)	
37	Front Floor Pan	Not Serviced	87	Front Pillar Lower Hinge Reinforcement (Serviced in 23-34-80)	
38	No. 1 to No. 2 Body Bolt Strainer	Not Serviced	88	Windshield Opening Lower Frame to Upper Steering Column Bracket (Serviced in 23-34-80)	
39	Body Side Inner Sill	23-51-5	89	Front Pillar Upper Hinge Reinforcement (Serviced in 23-34-80)	
40	Body Floor Pan Reinforcement	Not Serviced	90	Quarter Inner Panel Assembly	23-34-234
41	Front Floor Seat Track Reinforcement	Not Serviced	91	Body Lock Pillar	23-36-53
42	Body Side Sill Front End Cover	23-51-8	92	Roof Side Rail Extension	23-40-92
43	Body Side Outer Sill	23-51-5	93	Rear Window Side Frame to Wheelhouse Extension	Not Serviced
44	Body Floor Pan Reinforcement	Not Serviced	94	Deck Lid Hinge Body Bracket Support	23-19-82
45	Axle Drive Pinion Carrier Bumper Reinforcement	Not Serviced	95	Quarter Outside Panel Lower	23-34-235
46	Fuel Tank Rear Floor Pan Reinforcement	Not Serviced	96	Quarter Outside Panel Upper	23-34-235
47	No. 5 Body Bolt Floor Pan Reinforcement	Not Serviced	97	Quarter Outside Rear Panel or Extension	23-34-233
48	Fuel Tank Hanger	Not Serviced	98	Deck Opening Lower Panel Side Extension	23-34-176
49	Rear Floor Pan Side Extension	23-32-49	99	Deck Opening Upper Panel	23-34-166
50	Floor Pan Spare Wheel Bracket Reinforcement	Not Serviced			

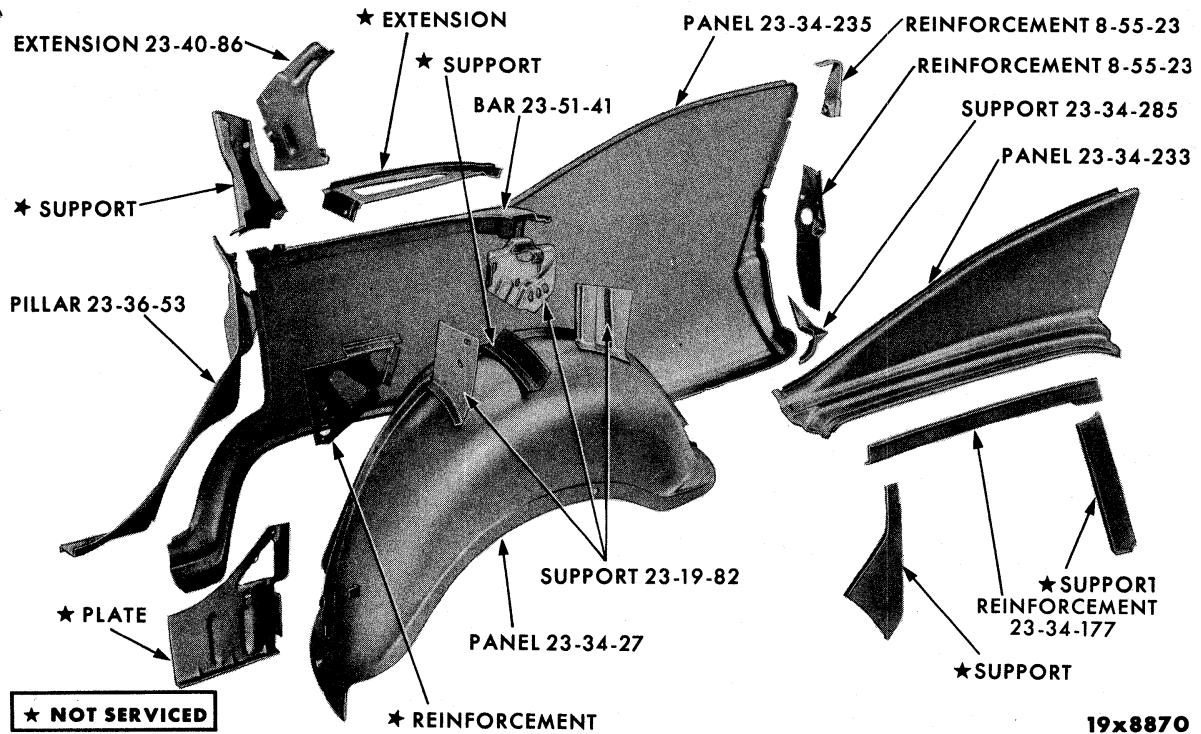

REAR QUARTER PANEL - PLYMOUTH PP1-2 4 DOOR SEDAN AND SPECIAL 4 DOOR SEDAN

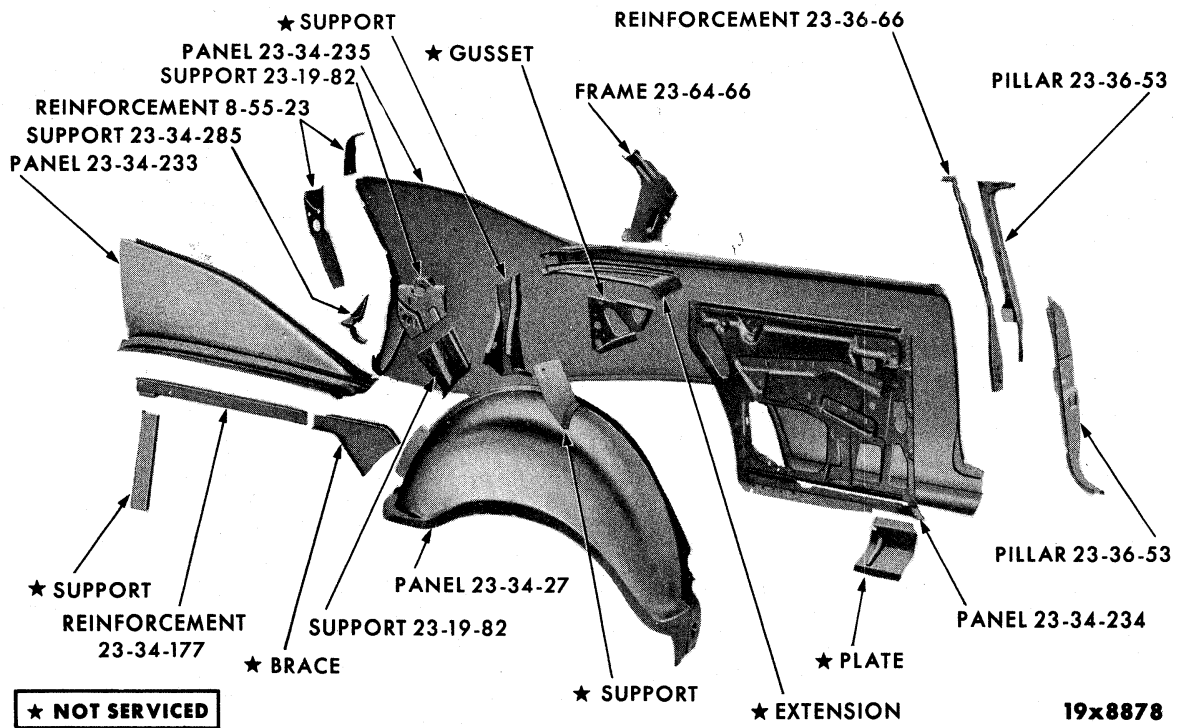

REAR QUARTER PANEL - PLYMOUTH PP1-2 CLUB SEDAN

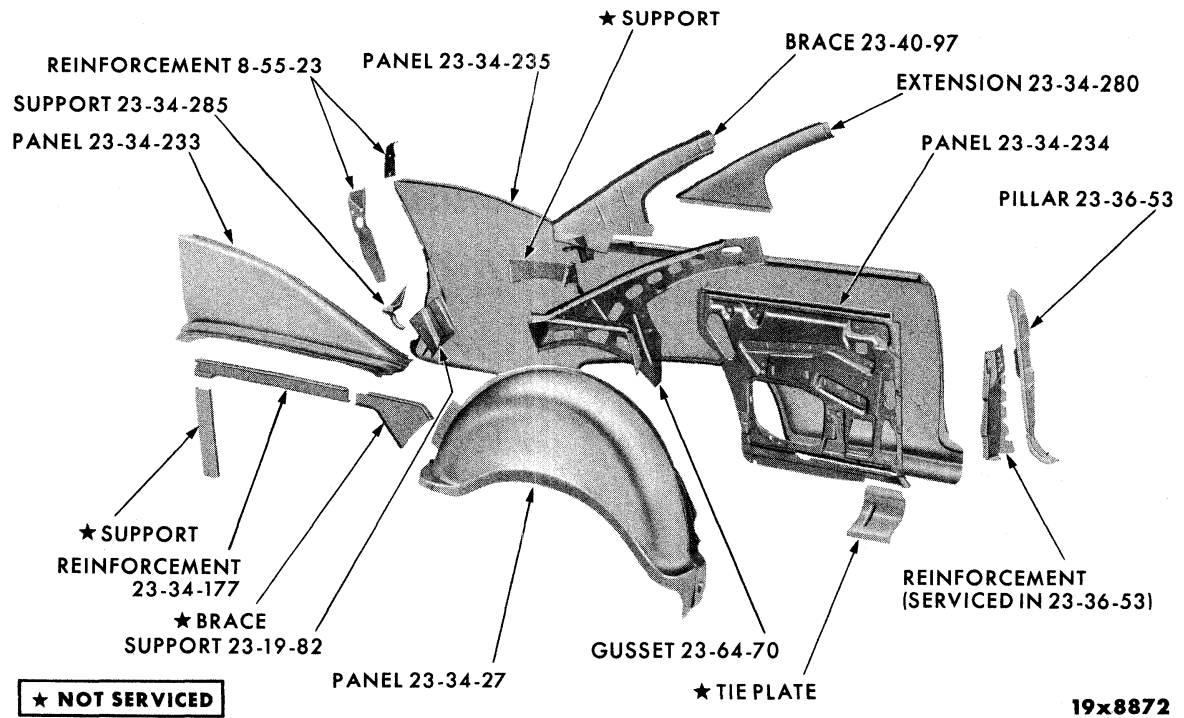

REAR QUARTER PANEL - PLYMOUTH PP1-2 SPECIAL CLUB COUPE

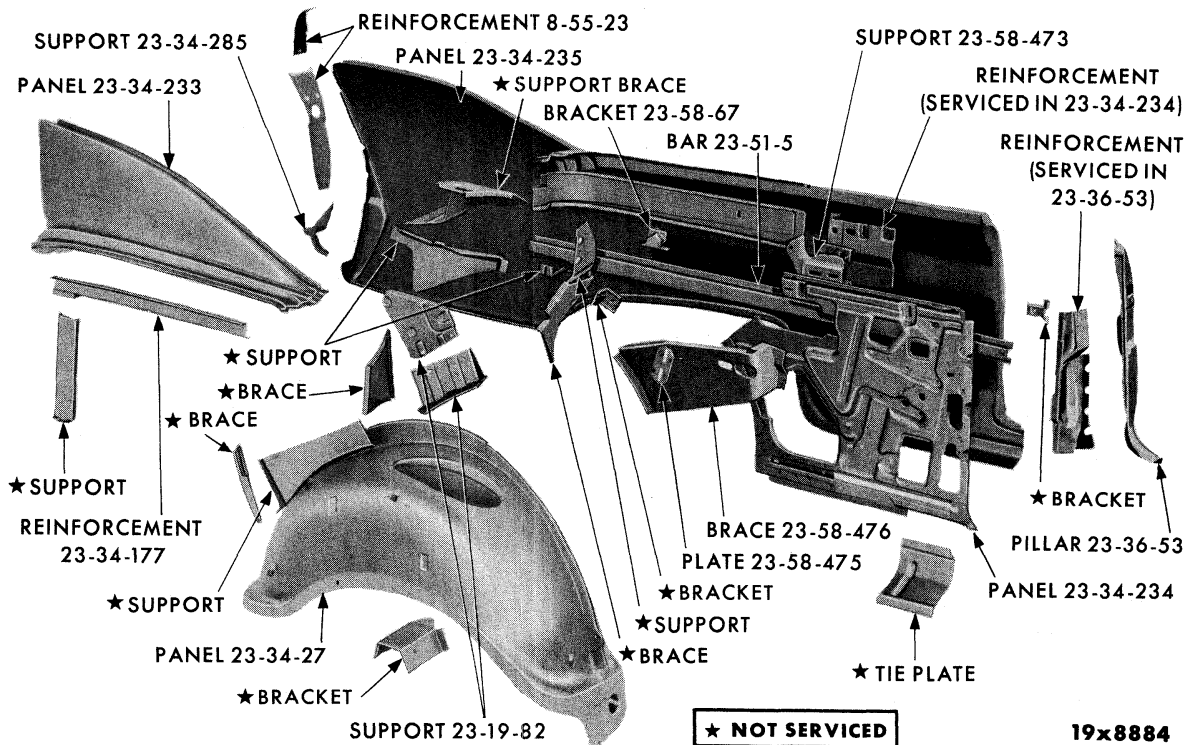

REAR QUARTER PANEL - PLYMOUTH PP1-2 CONVERTIBLE COUPE

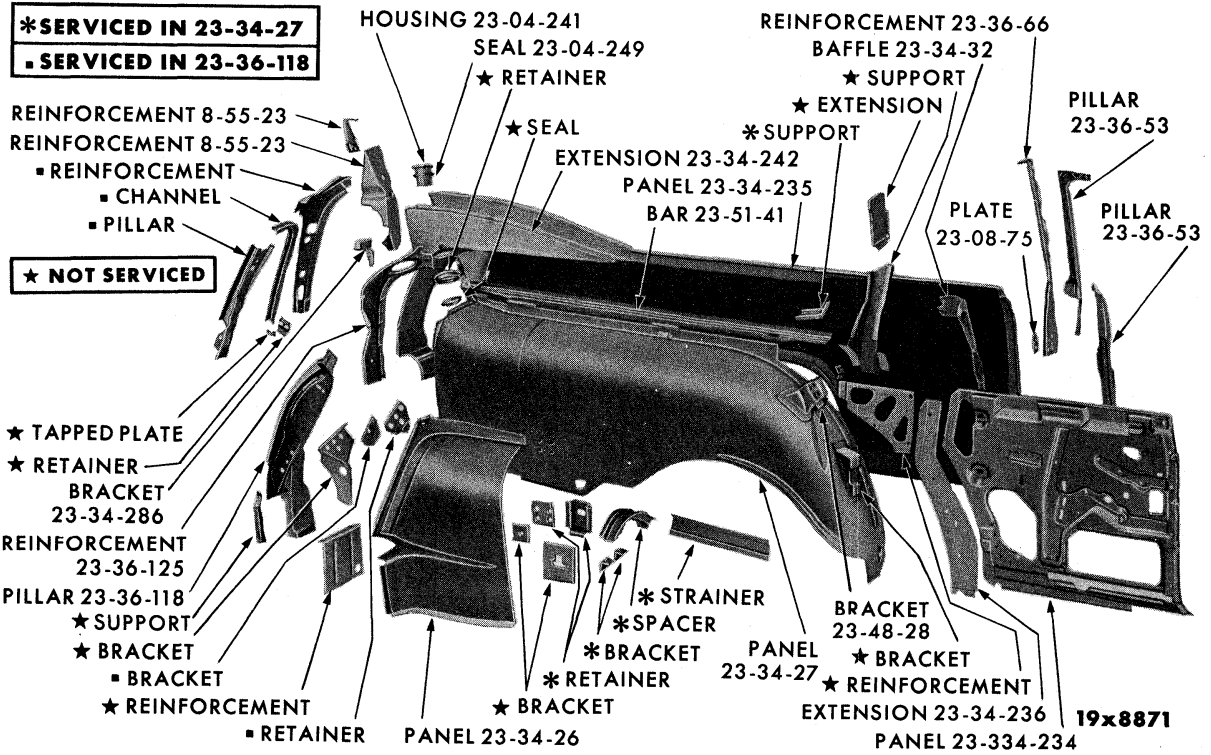

REAR QUARTER PANEL - PLYMOUTH PP1-2 2 DOOR SUBURBAN

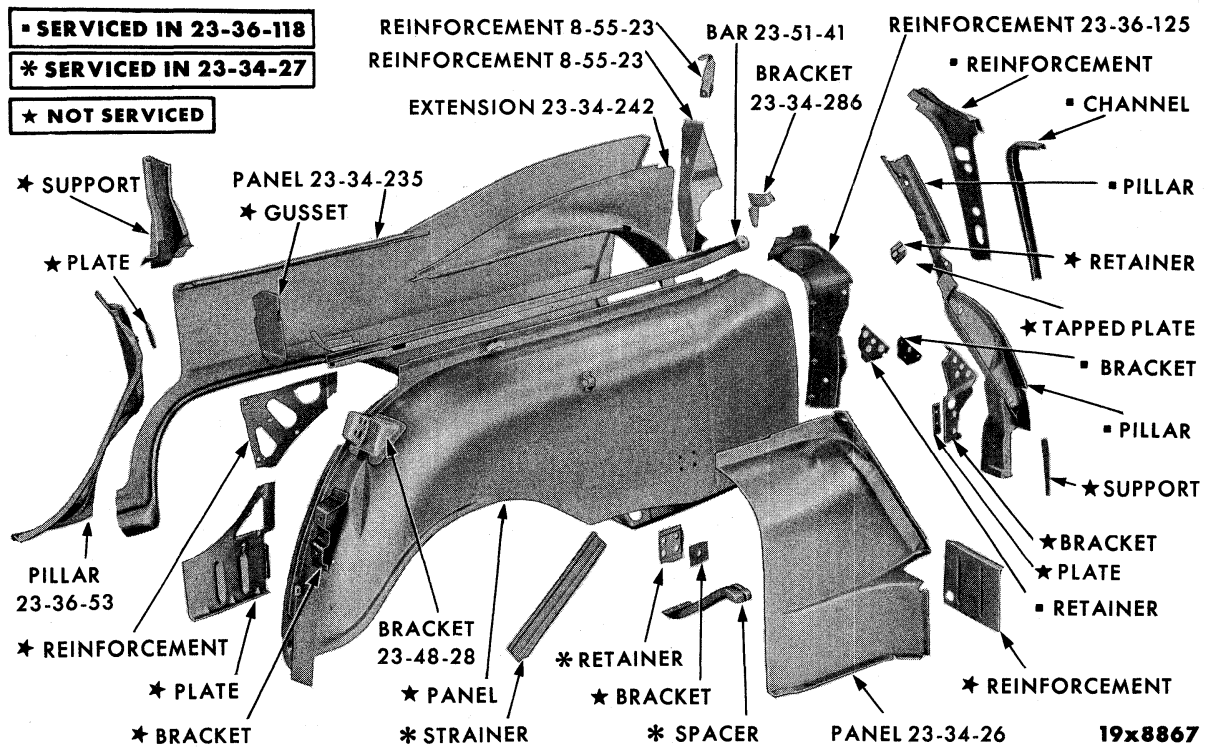

REAR QUARTER PANEL - PLYMOUTH PP1-2 4 DOOR SUBURBAN

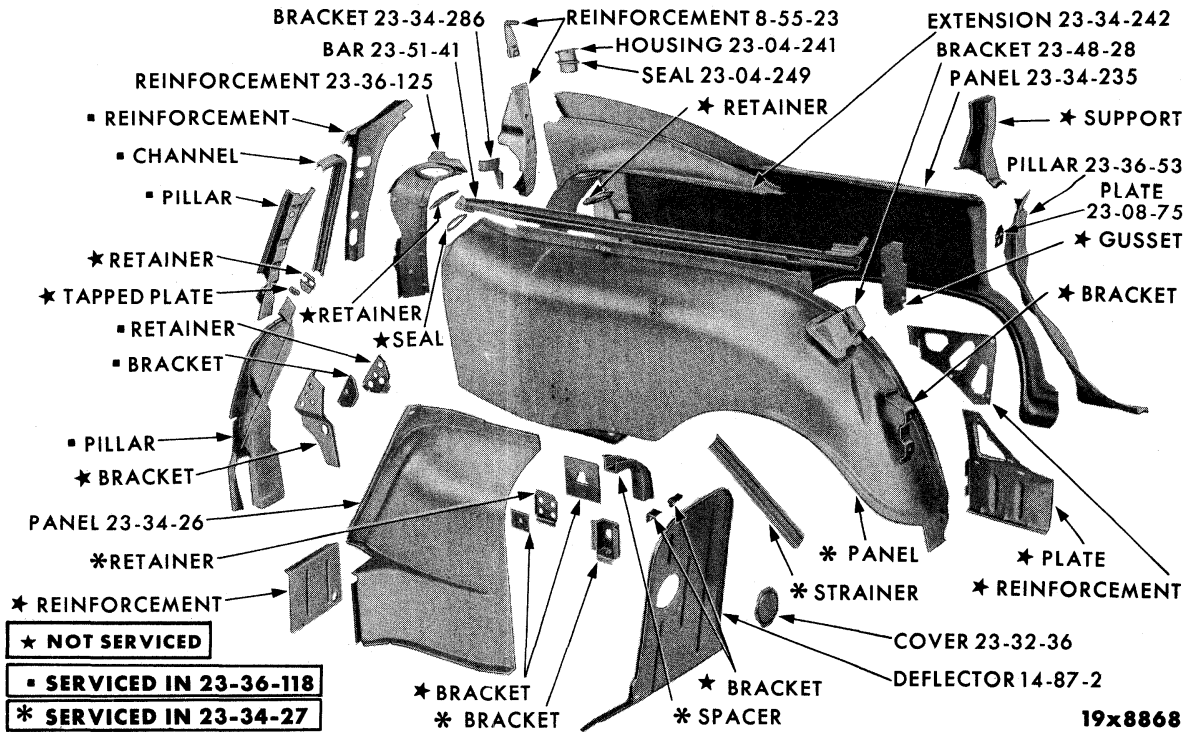

REAR QUARTER PANEL - PLYMOUTH PP1-2 4 DOOR SUBURBAN (LEFT-GAS TANK SIDE)

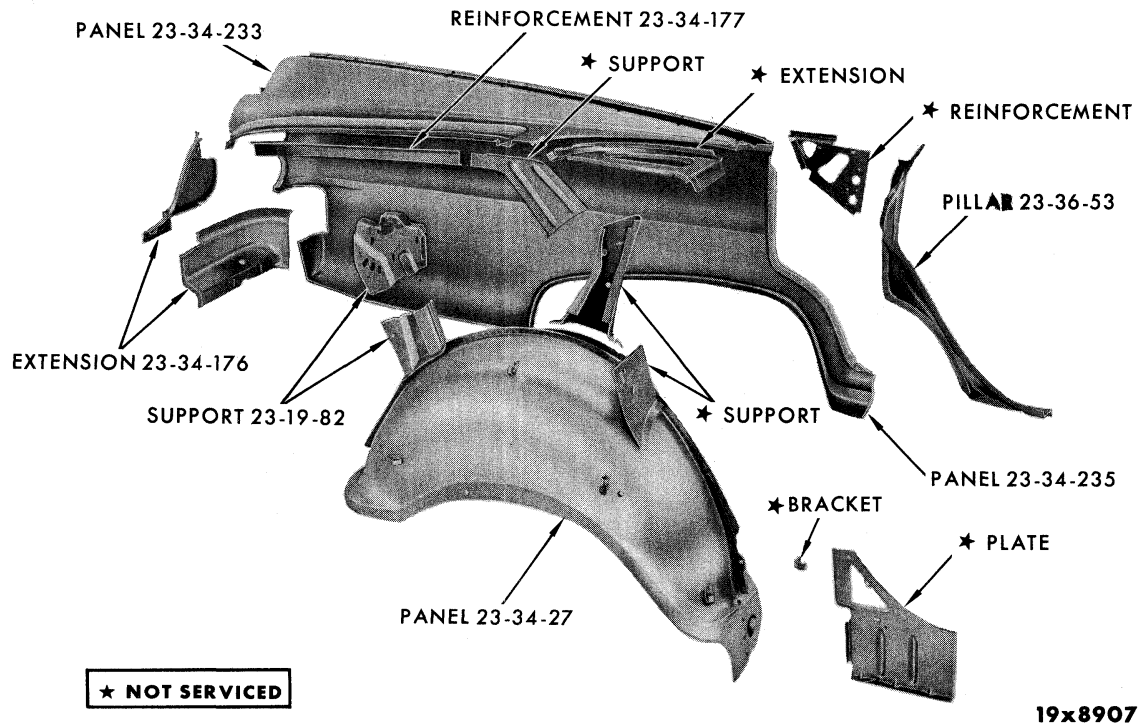

REAR QUARTER PANEL - DODGE PD3-4 4 DOOR SEDAN AND SPECIAL 4 DOOR SEDAN

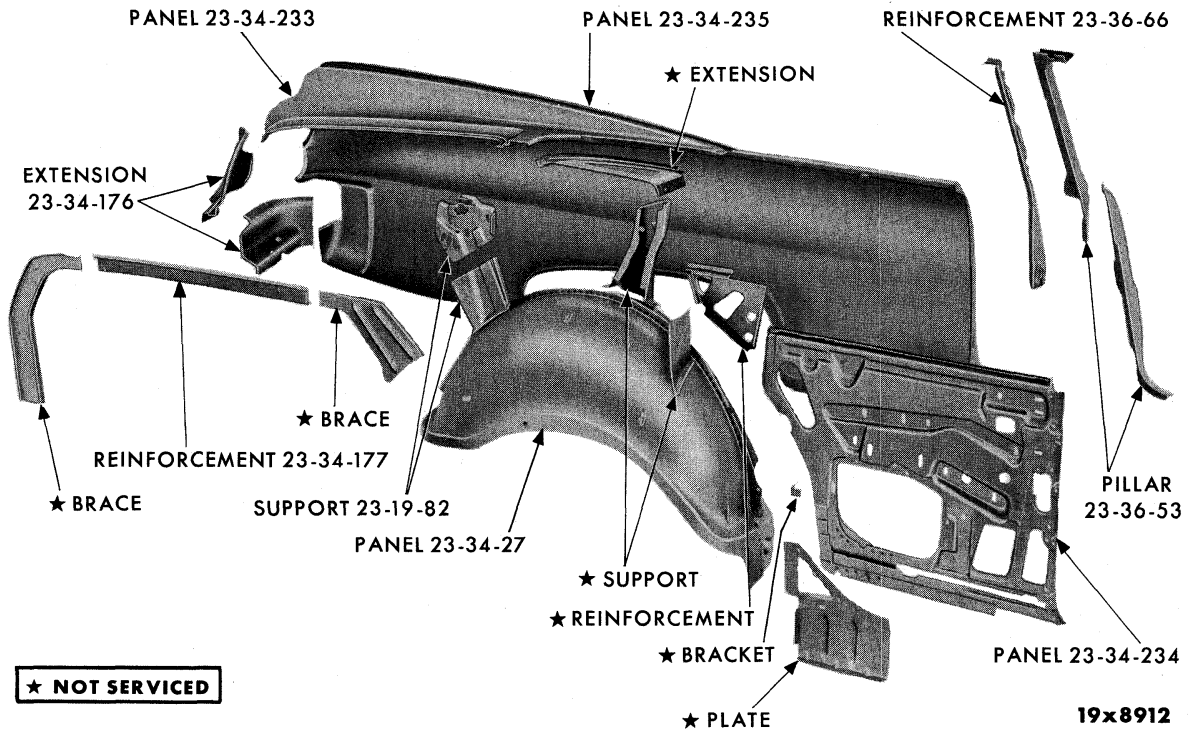

REAR QUARTER PANEL - DODGE PD3-4 CLUB SEDAN

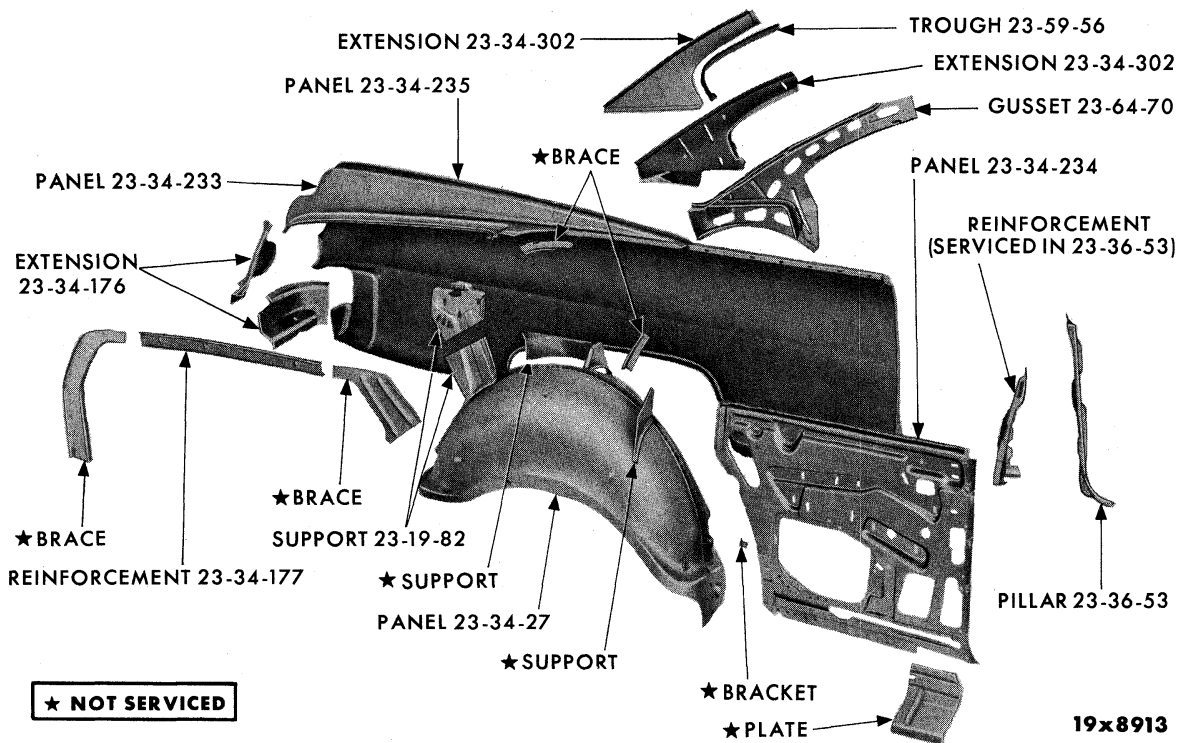

REAR QUARTER PANEL - DODGE PD3-4 SPECIAL CLUB COUPE

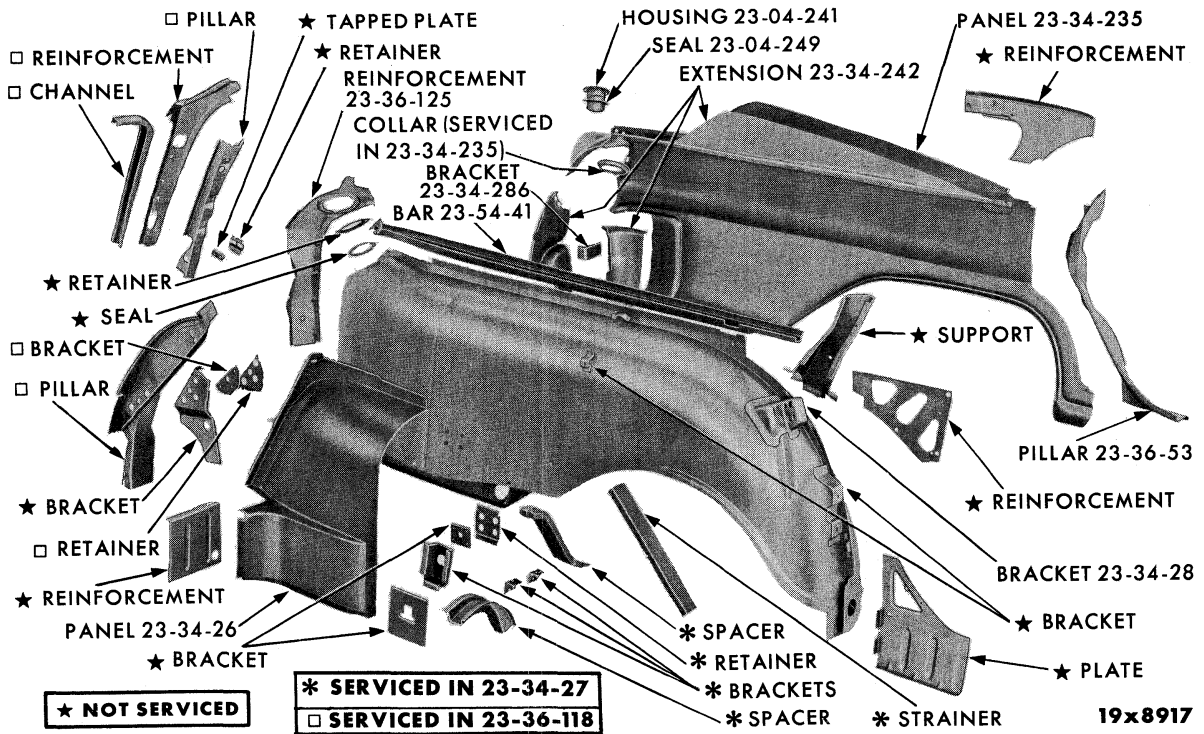

REAR QUARTER PANEL - DODGE PD3-4 4 DOOR SUBURBAN

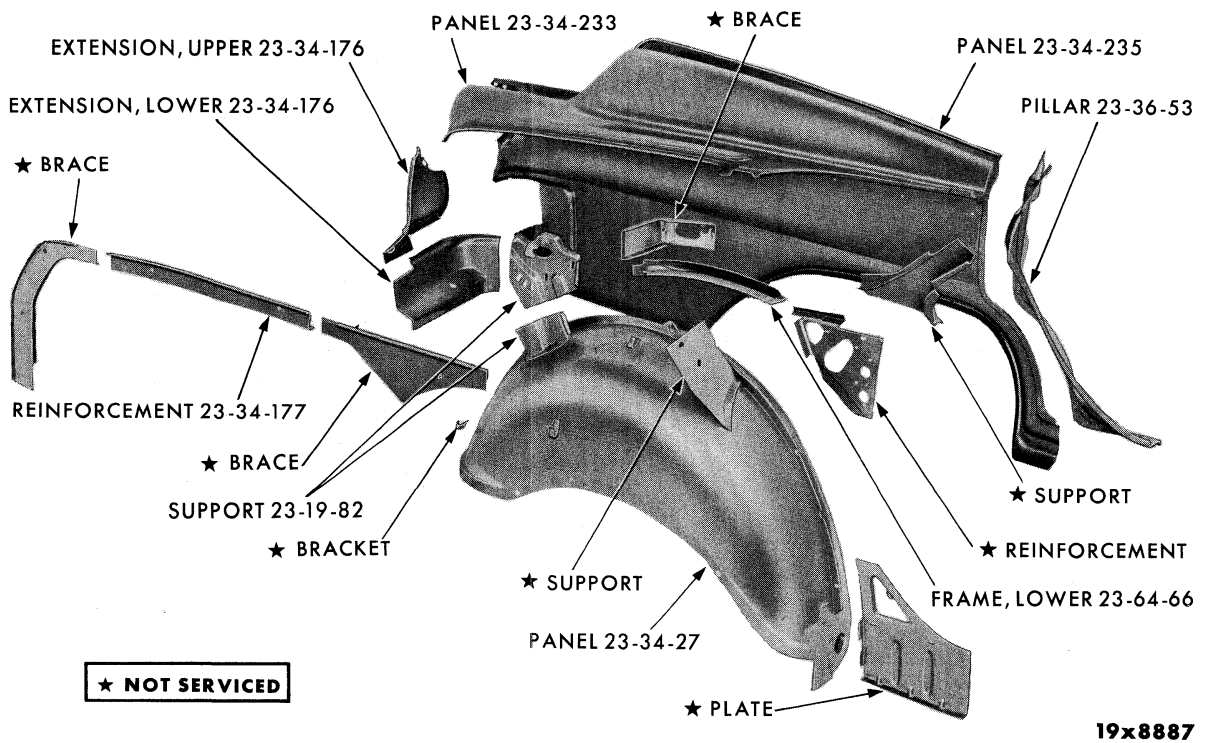

REAR QUARTER PANEL - DODGE PD1-2 4 DOOR SEDAN AND SPECIAL 4 DOOR SEDAN

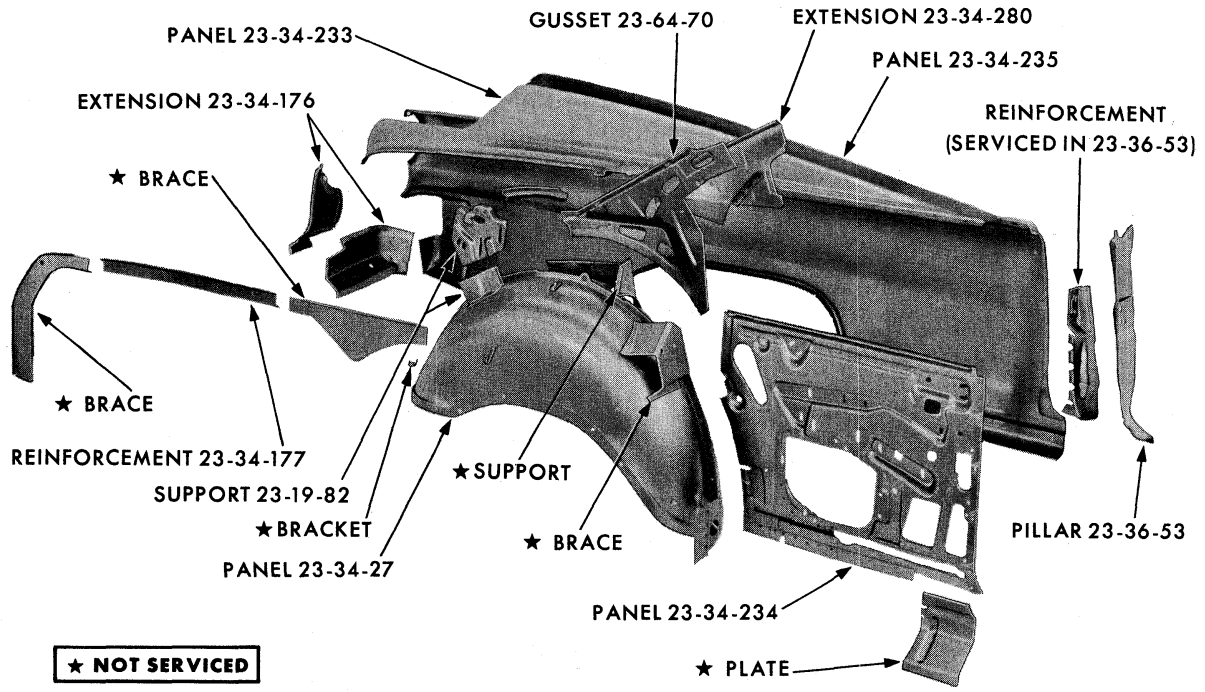

REAR QUARTER PANEL - DODGE PD1-2 SPECIAL CLUB COUPE

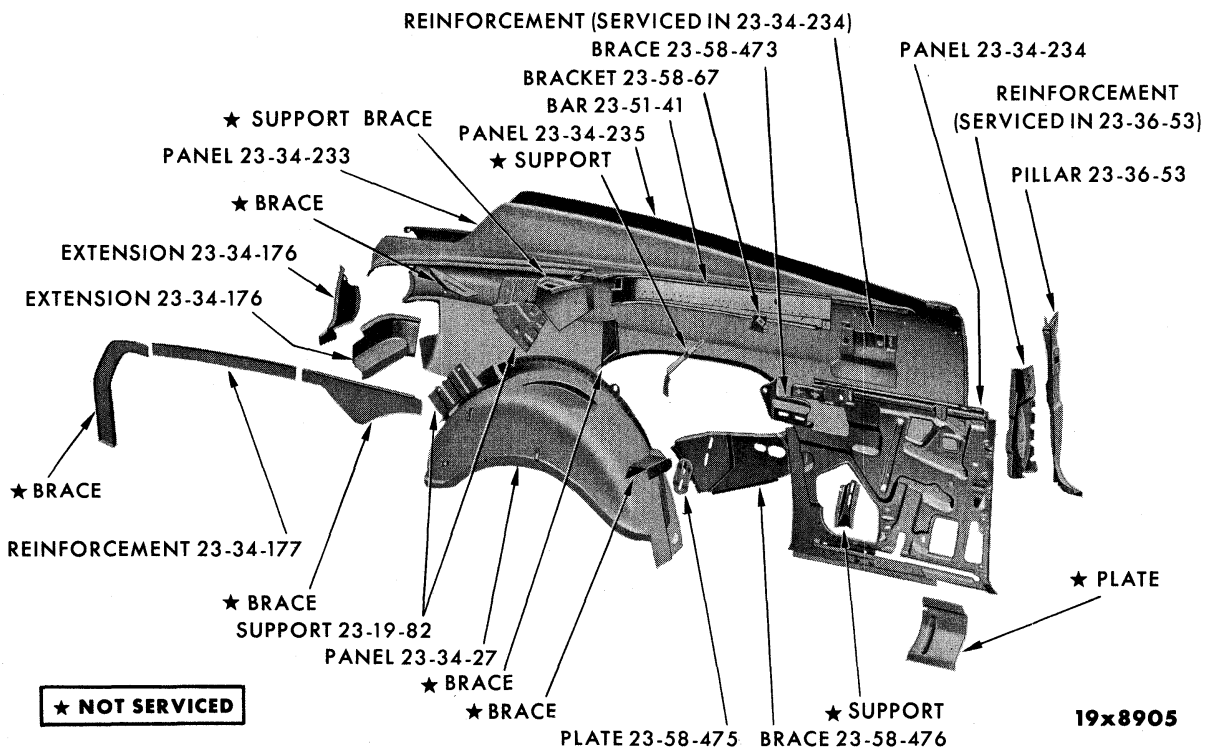

REAR QUARTER PANEL - DODGE PD1-2 CONVERTIBLE COUPE

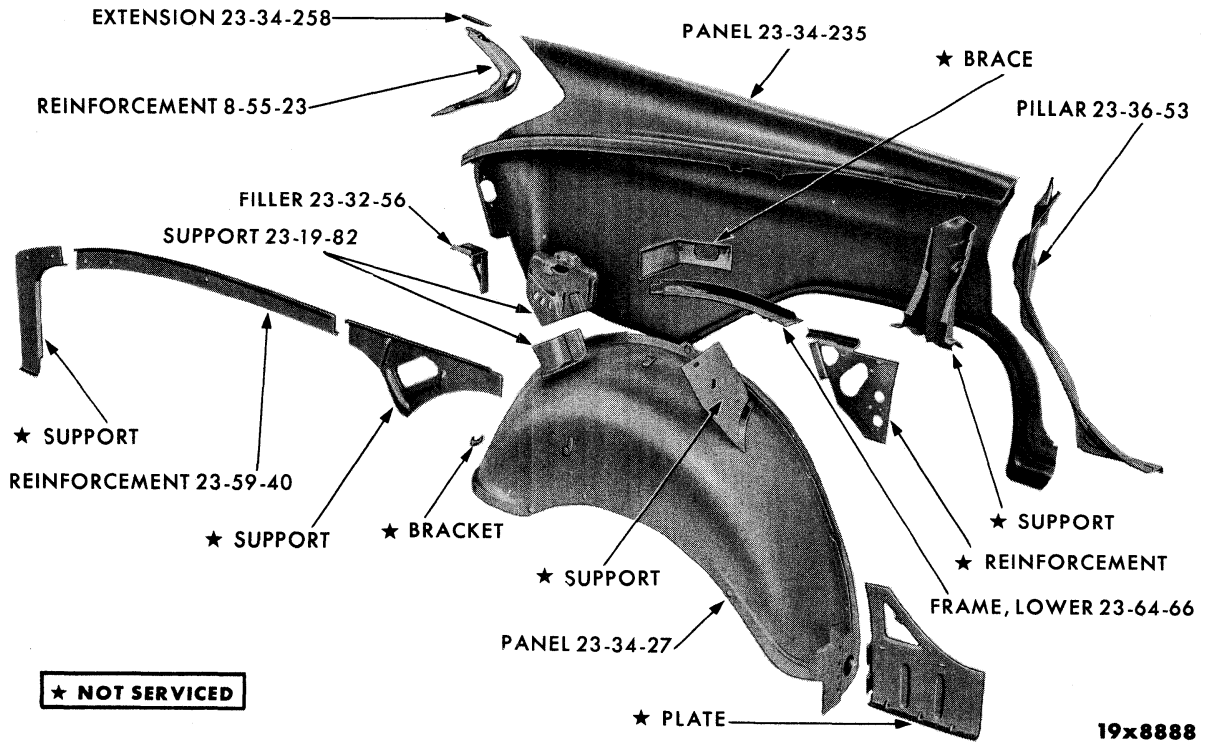

REAR QUARTER PANEL - DESOTO PS1-3 AND CHRYSLER PC1-2-3
4 DOOR SEDAN AND SPECIAL 4 DOOR SEDAN

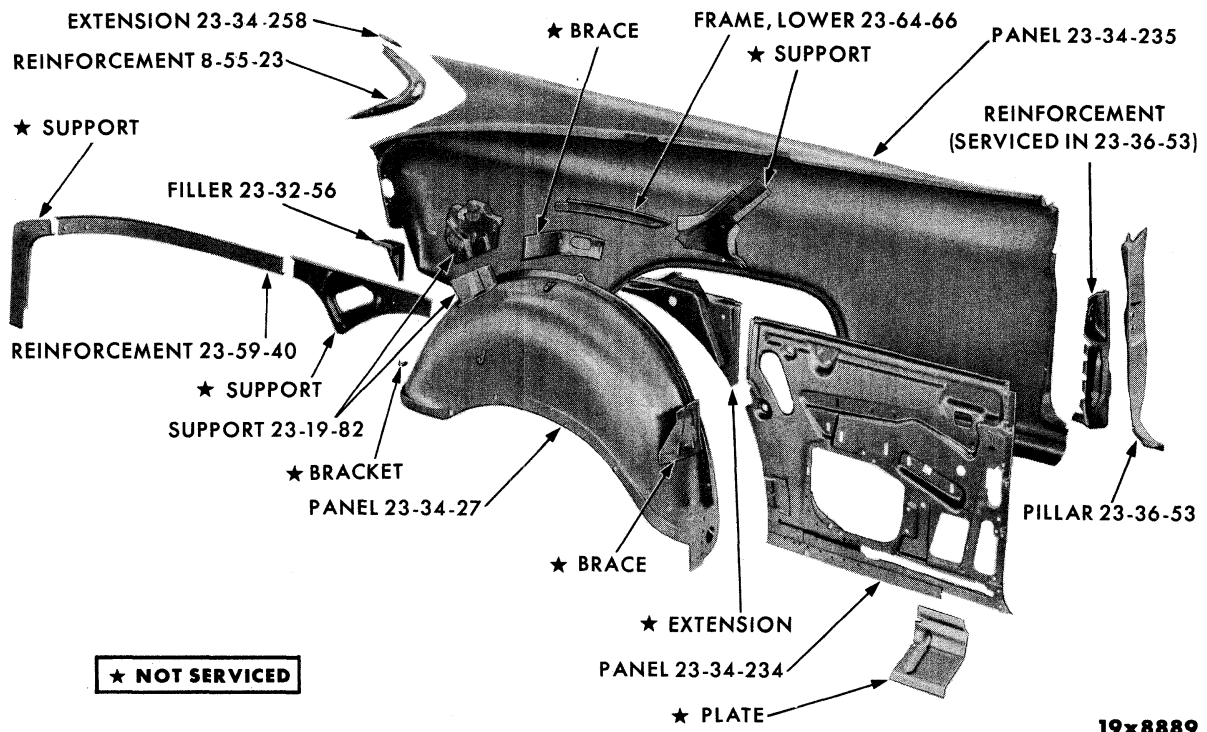

REAR QUARTER PANEL - DESOTO PS1-3 AND CHRYSLER PC1-2-3 SPECIAL CLUB COUPE

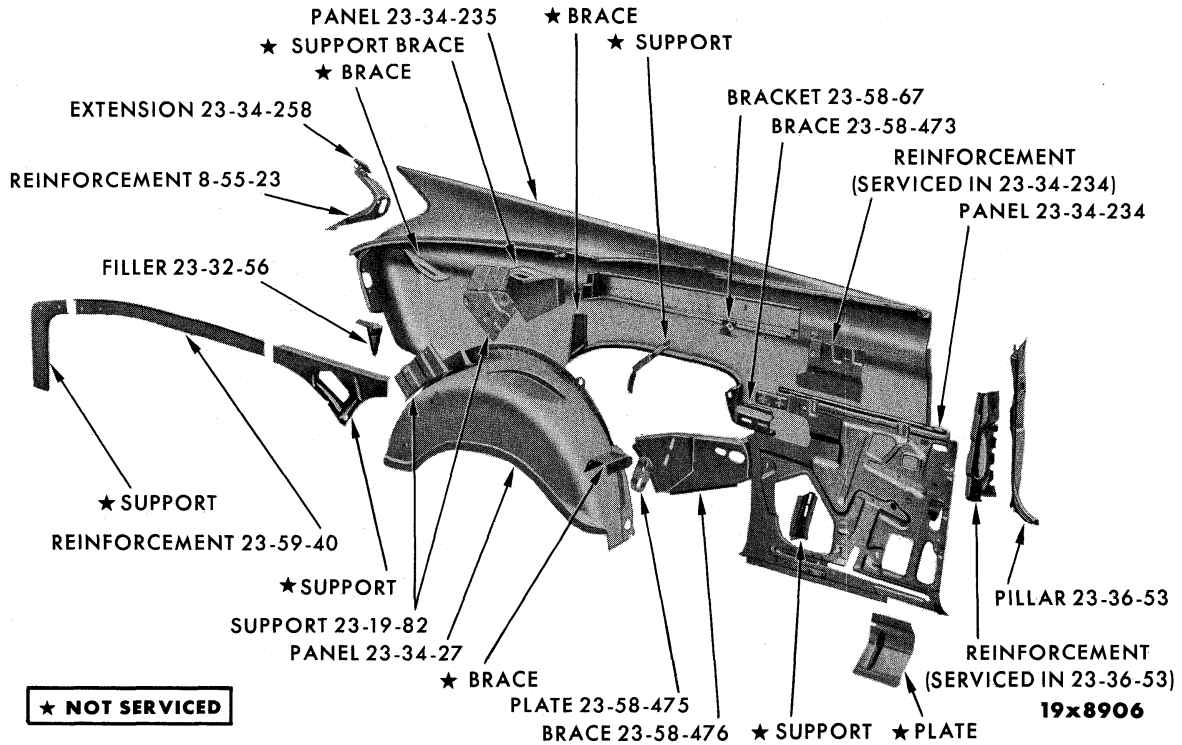

REAR QUARTER PANEL - CHRYSLER PC1-3-4 CONVERTIBLE COUPE

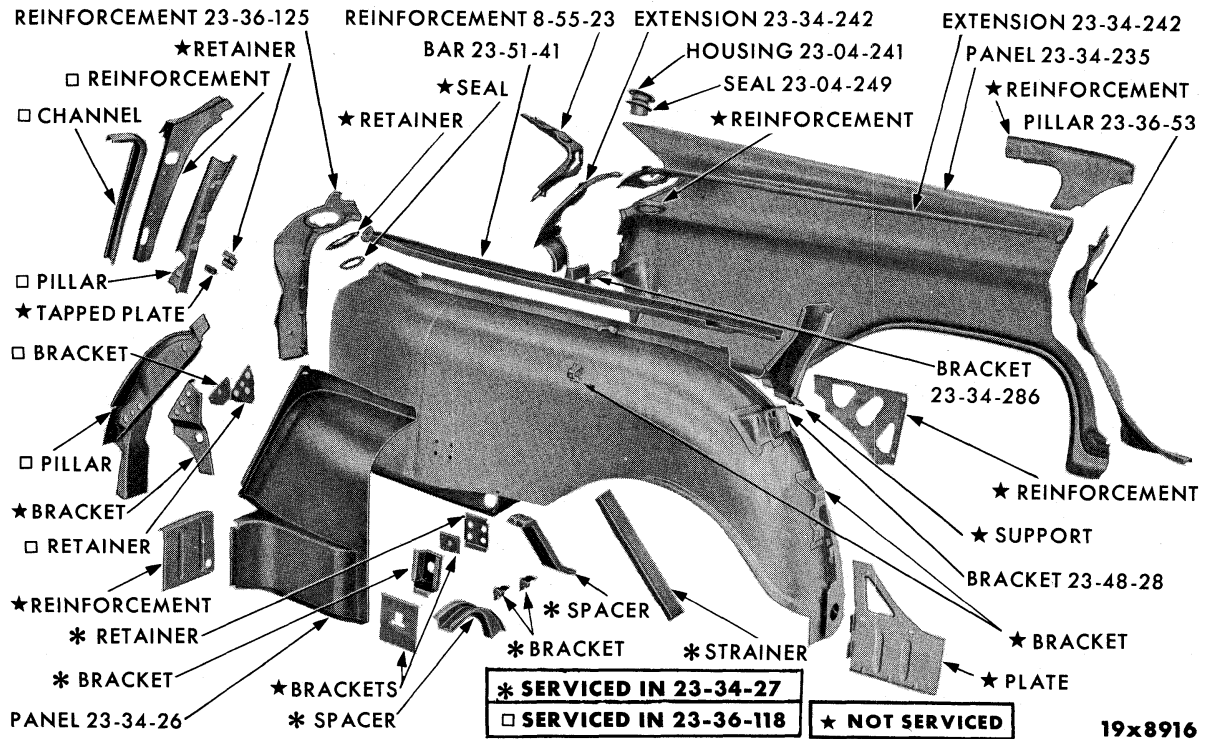

REAR QUARTER PANEL - CHRYSLER PC1-3 SPECIAL 4 DOOR SUBURBAN

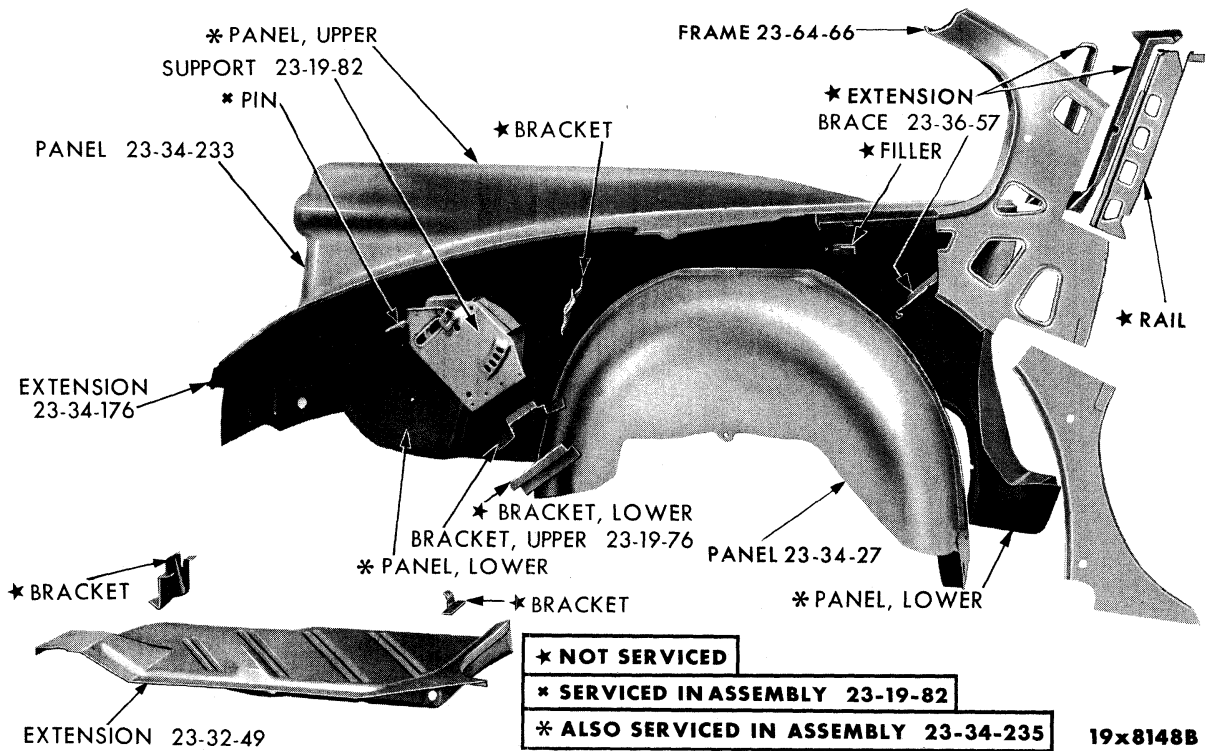

REAR QUARTER PANEL - IMPERIAL PY1 4 DOOR SEDAN

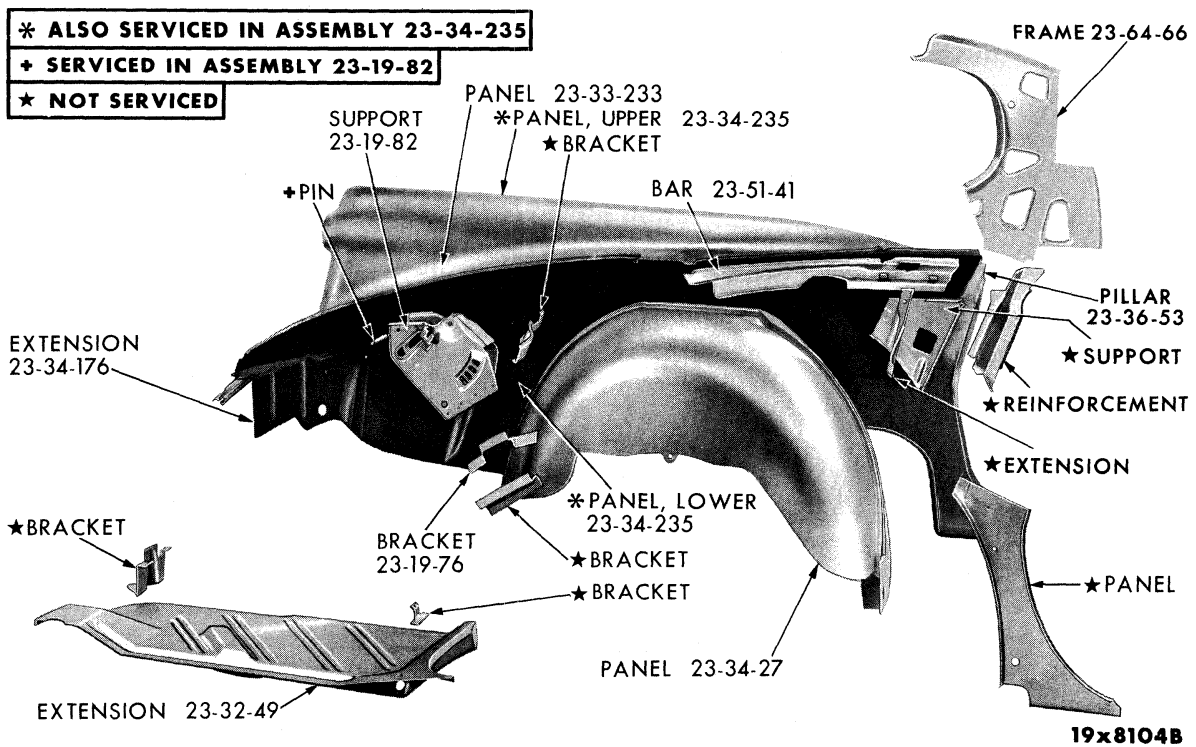

REAR QUARTER PANEL - IMPERIAL PY1 SPECIAL 4 DOOR SEDAN

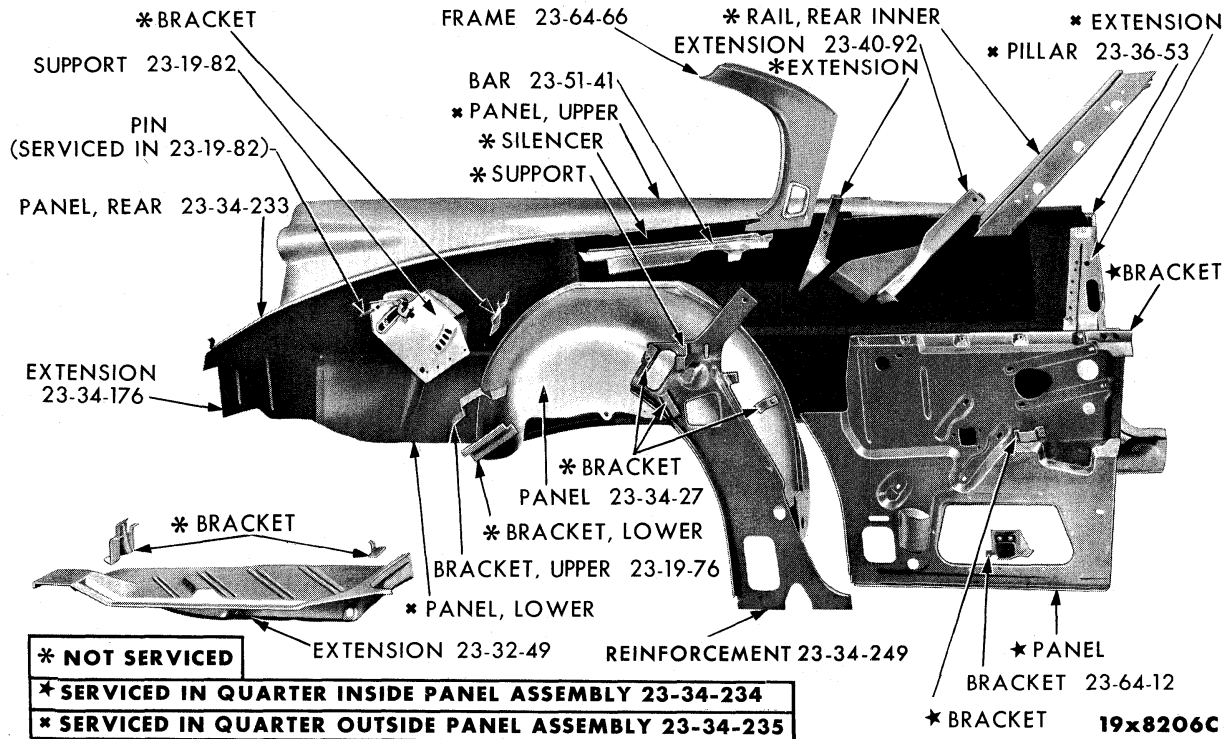

REAR QUARTER PANEL - IMPERIAL PY1 SPECIAL CLUB COUPE

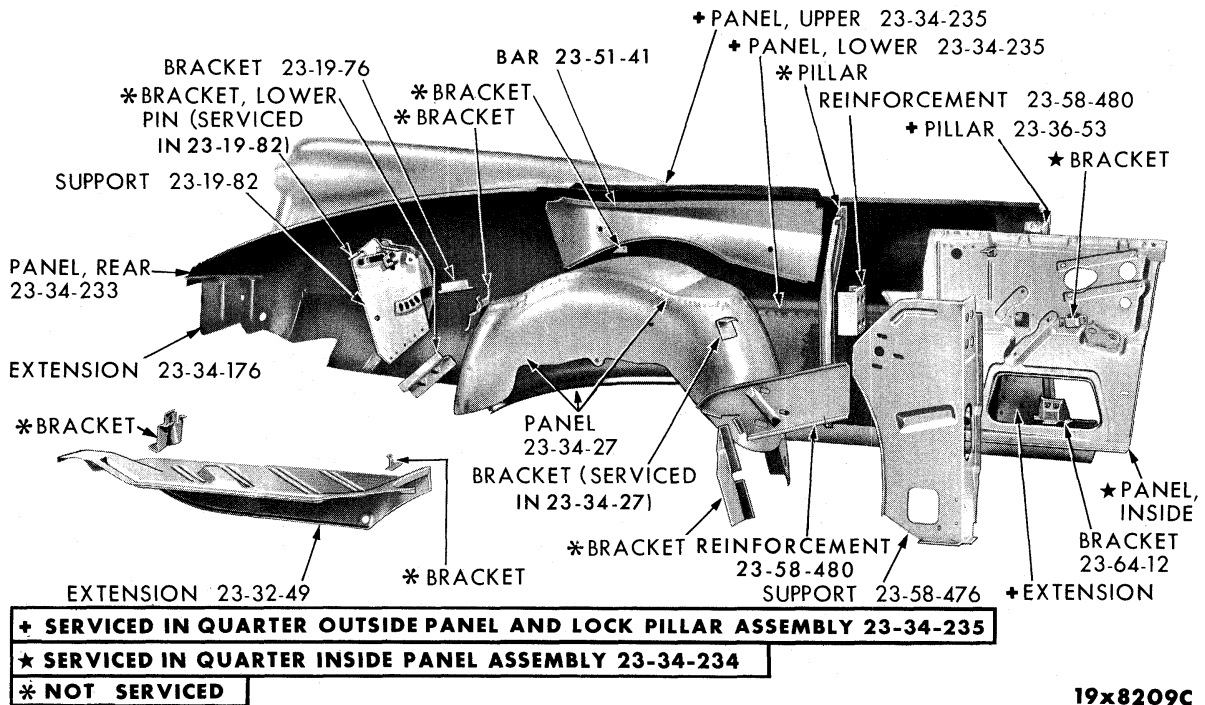

REAR QUARTER PANEL - IMPERIAL PY1 CONVERTIBLE COUPE

1960 PLYMOUTH Savoy MOULDINGS for 4 Door Sedans,
Special 4 Door Sedans and 4 Door Suburbans

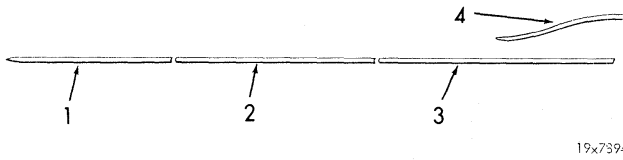

19x7394

REF. NO.	PART NUMBER	DESCRIPTION
1	2084 552-3	MOULDING PACKAGE, Front Door
	*10-6000 836	Clip
2	2084 554-5	MOULDING PACKAGE, Rear Door, 4D, Sp. 4D.
	*8-6000 836	Clip
	*2-6006 514	Retainer and Bolt
	*2-151 497	Nut
	2196 196-7	MOULDING PACKAGE, Rear Door, Sub.
	8-6010 210	Clip
	*2-6006 514	Clip and Bolt
	2-151 497	Nut
3	2084 558-9	MOULDING PACKAGE, Quarter Panel, 4D., Sp. 4D.
	*12-6000 836	Clip
	2-6000 745	Clip and Seal
	*2-151 497	Nut
	2196 190-1	MOULDING PACKAGE, Quarter Panel, Sub.
	*16-6000 733	Clip and Seal
4	2084 560-1	MOULDING PACKAGE, Quarter Panel, 4D., Sp. 4D.
	2-6000 730	Retainer and Bolt
	*2-151 497	Nut
	10-6000 686	Clip
	2196 176-7	MOULDING PACKAGE, Quarter Panel, Sub.
	8-6000 686	Clip
	2-6006 265	Clip

1960 PLYMOUTH Savoy MOULDINGS for Special Club Coupes, Club Sedans and 2 Door Suburbans

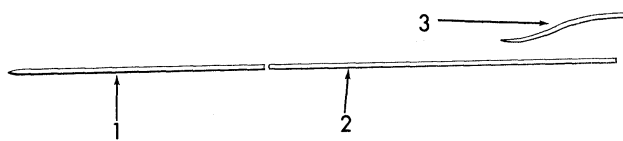

19x7897

REF. NO.	PART NUMBER	DESCRIPTION
1	2084 550-1	MOULDING PACKAGE, Door
	*12-6000 836	Clip
2	*2084 556-7	MOULDING PACKAGE, Quarter Panel, Sp. Cl. Cp., Cl. Sed.
	*18-6000 836	Clip and Seal
	2-6000 745	Clip and Bolt
	*2-151 497	Nut
	2196 188-9	MOULDING PACKAGE, Quarter Panel, Sub.
	*22-6000 733	Clip and Seal

REF. NO.	PART NUMBER	DESCRIPTION
3	*2084 560-1	MOULDING PACKAGE, Quarter Panel, Sp. Cl. Cp., Cl. Sed.
	*2-6000 730	Retainer and Bolt
	*2-151 497	Nut
	10-6000 686	Clip
	2196 176-7	MOULDING PACKAGE, Quarter Panel, Sub.
	8-6000 686	Clip
	2-6006 265	Clip

1960 PLYMOUTH Belvedere and Fury MOULDINGS for 4 Door Sedans, Special 4 Door Sedans and 4 Door Suburbans

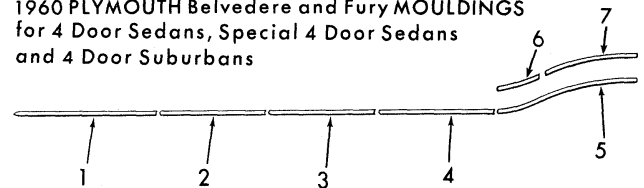

19x7895

REF. NO.	PART NUMBER	DESCRIPTION
1	2196 170-1	MOULDING PACKAGE, Front Fender
	2-6010 219	Clip
	8-6010 210	Clip
	4-6010 029	Clip and Bolt
	4-151 497	Nut
2	2084 570-1	MOULDING PACKAGE, Front Door, 4D., Sp. 4D.
	10-6010 210	Clip
	*2196 198-9	MOULDING PACKAGE, Front Door, Sub.
	*10-6010 210	Clip
3	2084 572-3	MOULDING PACKAGE, Rear Door, 4D., Sp. 4D.
	10-6010 210	Clip
	2196 182-3	MOULDING PACKAGE, Rear Door, Sub.
	8-6010 210	Clip
	*2-6006 514	Clip and Bolt
	2-151 497	Nut
4	2084 574-5	MOULDING PACKAGE, Quarter Panel, 4D, Sp. 4D.
	2-6010 210	Clip
	2-6000 738	Clip and Seal
	2-6000 730	Retainer and Bolt
	*2-151 497	Nut
	2196 194-5	MOULDING PACKAGE, Quarter Panel, Sub.
	6-6010 210	Clip
5	2-2084 565	MOULDING PACKAGE, Quarter Panel, 4D., Sp. 4D.
	10-6000 686	Clip
6	2196 192-3	MOULDING PACKAGE, Quarter Panel, Sub.
	2-6000 686	Clip
	2-6006 462	Clip
	2-6010 210	Clip
7	2196 178-9	MOULDING PACKAGE, Quarter Panel, Sub.
	8-6000 686	Clip

* Indicates use as required.

□ Indicates parts not listed in any previous parts book.

* Indicates change or addition.

Numerals in parentheses () refer to notes.

Printed in U.S.A.

Prices and specifications subject to change without notice.

1960 PLYMOUTH Belvedere and Fury MOULDINGS for Special Club Coupes, Convertible Coupes and Club Sedans

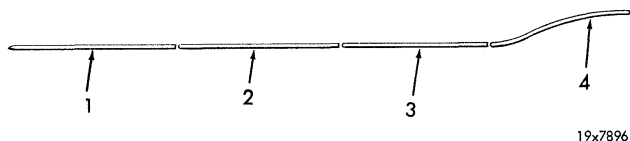

19x7896

REF. NO.	PART NUMBER	DESCRIPTION
1	2196 170-1	MOULDING PACKAGE, Front Fender
	2-6010 219	Clip
	8-6010 210	Clip
	4-6010 029	Clip and Bolt
	4-151-497	Nut
2	2084 566-7	MOULDING PACKAGE, Door
	12-6010 210	Clip
3	2084 568-9	MOULDING PACKAGE, Quarter Panel
	2-6010 210	Clip
	2-6000 741	Clip
	2-6000 740	Clip
	*2-6000 800	Clip
	*2-6000 801	Clip
	2-6000 739	Clip and Seal
	2-6000 730	Retainer and Bolt
	*2-151 497	Nut
4	2-2084 565	MOULDING PACKAGE, Quarter Panel
	10-6000 686	Clip

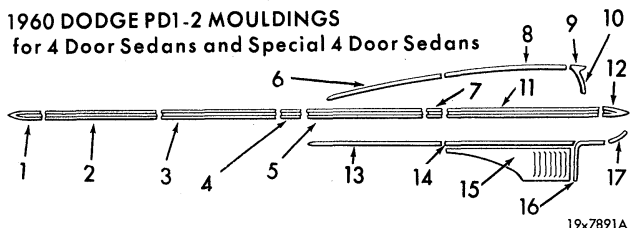

19x7891A

REF. NO.	PART NUMBER	DESCRIPTION
1	2-2196 428	CAP PACKAGE, Front Fender Moulding
	2-6006 143	Clip
	2-446 059	Nut
2	2196 426-7	MOULDING PACKAGE, Front Fender
	2-6006 429	Clip
	10-6000 710	Clip
3	2196 368-9	MOULDING PACKAGE, Front Door
	8-6000 710	Clip
4	2196 370-1	MOULDING PACKAGE, Front Door
	2-6000 780	Clip
	*2-2165 357	Screw and Washer
5	2196 372-3	MOULDING PACKAGE, Rear Door
	8-6000 710	Clip
6	2196 376-7	MOULDING PACKAGE, Rear Door
	8-6000 788	Clip
7	2196 374-5	MOULDING PACKAGE, Rear Door
	2-6000 780	Clip
	*2-2165 357	Screw and Washer
8	2196 388-9	MOULDING PACKAGE, Quarter Panel
	12-6000 788	Clip and Seal

REF. NO.	PART NUMBER	DESCRIPTION
9	*1-2196 406	MOULDING PACKAGE, Quarter Panel, Right
	*1-2196 877	MOULDING PACKAGE, Quarter Panel, Left
	2-125 591	Screw
	4-151 497	Nut
	2-6006 160	Washer
10	2-2196 417	INSERT PACKAGE, Quarter Panel Moulding, PD1
	2-2196 416	INSERT PACKAGE, Quarter Panel Moulding, PD2
	4-1961 538	SEAL
	2-6006 160	Washer
	4-151 497	Nut
11	2196 384-5	MOULDING PACKAGE, Quarter Panel
	12-6000 716	Clip
12	2-2196 367	MOULDING PACKAGE, Quarter Panel
	*2-6010 029	Clip
	*2-6000 834	Clip
	2-1963 302	RETAINER
	*2-2165 097	Nut
	2-6000 028	Nut
13	2196 378-9	MOULDING PACKAGE, Rear Door
	8-6000 736	Clip
14	2196 394-5	MOULDING PACKAGE, Quarter Panel
	12-6000 735	Clip
15	2196 402-3	PANEL PACKAGE, Quarter Panel Finish
	*2-6000 700	Retainer and Bolt
	2-6000 028	Nut and Seal
	10-125 978	Screw
16	2196 392-3	MOULDING PACKAGE, Quarter Panel
	*4-6000 137	Clip and Seal
	2-125 978	Screw
17	2196 390-1	MOULDING PACKAGE, Quarter Panel
	*6-6000 793	Clip and Bolt
	*6-151 497	Nut

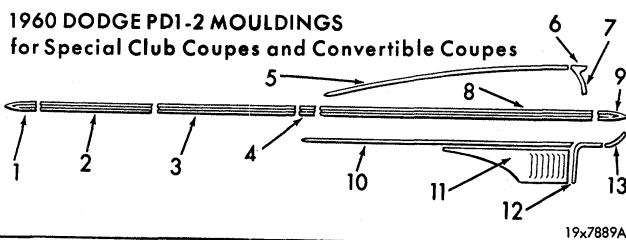

19x7889A

REF. NO.	PART NUMBER	DESCRIPTION
1	2-2196 428	CAP PACKAGE, Front Fender Moulding
	2-6006 143	Clip
	2-446 059	Nut
2	2196 426-7	MOULDING PACKAGE, Front Fender
	2-6006 429	Clip
	10-6000 710	Clip

★ Indicates use as required.

□ Indicates parts not listed in any previous parts book.

April 20, 1960 Supersedes Dec. 30, 1959

Numerals in parentheses () refer to notes.

Printed in U.S.A. Prices and specifications subject to change without notice.

* Indicates change or addition.

REF. NO.	PART NUMBER	DESCRIPTION
3	2196 380-1	MOULDING PACKAGE, Door
	10-6000 710	Clip
4	2196 382-3	MOULDING PACKAGE, Door
	2-6000 717	Clip
	*2-2165 357	Screw
5	2-2196 835	MOULDING PACKAGE, Quarter Panel
	18-6000 788	Clip and Seal
	2-125 591	Screw
6	*1-2196 406	MOULDING PACKAGE, Quarter Panel, Right
	*1-2196 877	MOULDING PACKAGE, Quarter Panel, Left
	2-125 591	Screw
	4-151 497	Nut
	2-6006 160	Washer
7	2-2196 417	INSERT PACKAGE, Quarter Panel Moulding, PD1
	*2-2196 416	INSERT PACKAGE, Quarter Panel Moulding, PD2
	4-1961 538	Seal
	4-151-497	Nut
8	2196 396-7	MOULDING PACKAGE, Quarter Panel
	18-6000 716	Clip
9	2-2196 367	MOULDING PACKAGE, Quarter Panel
	2-1963 302	RETAINER
	2-6000 720	Clip and Bolt
	2-6000 028	Nut and Seal
10	2196 398-9	MOULDING PACKAGE, Quarter Panel
	18-6000 735	Clip
11	2196 402-3	PANEL, Quarter Panel Finish
	2-6000 700	Retainer and Bolt
	2-6000 028	Nut and Seal
	10-125 978	Screw
12	2196 392-3	MOULDING PACKAGE, Quarter Panel
	2-125 978	Screw
	4-6000 793	Clip and Bolt
	4-6006 492	Clip
13	2196 390-1	MOULDING PACKAGE, Quarter Panel
	*4-6000 137	Clip and Seal
	*2-125 978	Screw

REF. NO.	PART NUMBER	DESCRIPTION
3	*1963 136-7	MOULDING, Rear Door
	2-145 186	Screw
4	2-2196 109	ORNAMENT PACKAGE, Rear Door Moulding
	4-6006 264	Nut
5	2-2196 362	MOULDING PACKAGE, Quarter Panel
	18-6000 788	Clip and Seal
6	2196 418-9	MOULDING PACKAGE, Quarter Panel
	8-1963 070	Seal
	4-151 497	Nut
7	*2-1881 736	REFLECTOR PACKAGE, Quarter Panel Moulding
	*2 ---- ---	Reflector
	*2 ---- ---	Retainer
	*2 ---- ---	Gasket
8	*2196 358-9	MOULDING PACKAGE, Quarter Panel
	12-6000 755	Clip
9	*2196 350-1	MOULDING PACKAGE, Rear Door
	1963 182-3	RETAINER
	4-6006 461	Clip
10	*1963 110-1	PANEL, Rear Door Finish, PD3-H, PD4-H
	1964 320-1	PANEL, Rear Door Finish, PD3-M, PD4-M
11	*2196 352-3	MOULDING PACKAGE, Rear Door, PD3-H, PD4-H
	2-6000 749	Clip
	4-6000 754	Clip and Seal
	1963 182-3	RETAINER
	2-159 254	Screw
	2-131 044	Washer
	2196 296-7	MOULDING PACKAGE, Rear Door, PD3-M, PD4-M
	1963 182-3	RETAINER
	4-6000 754	Clip and Seal
12	*2196 841-2	MOULDING PACKAGE, Quarter Panel, PD3-H, PD4-H
	*2 ---- ---	Screw
13	*2196 354-5	MOULDING PACKAGE, Quarter Panel, PD3-H, PD4-H
	16-6000 754	Clip and Seal
14	*1963 112-3	PANEL, Quarter Panel Finish, PD3-H, PD4-H

1960 DODGE PD3-4 MOULDINGS for 4 Door Sedans and Special 4 Door Sedans

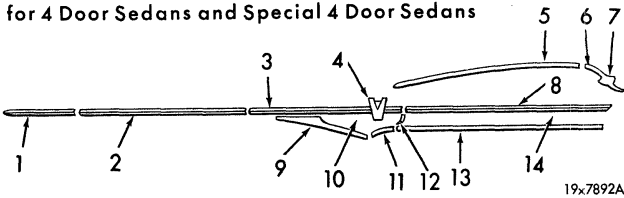

19x7892A

1960 DODGE PD3-4 MOULDINGS for Special Club Coupes, Convertible Coupes and Club Sedans

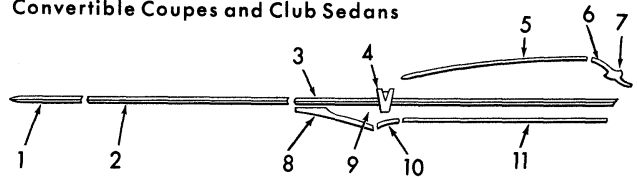

19x7890A

REF. NO.	PART NUMBER	DESCRIPTION
1	2196 424-5	MOULDING PACKAGE, Front Fender
	4-6010 215	Clip
2	2196 110-1	MOULDING PACKAGE, Front Door
	12-6000 744	Clip

REF. NO.	PART NUMBER	DESCRIPTION
1	2196 424-5	MOULDING PACKAGE, Front Fender
	4-6010 215	Clip
2	2196 112-3	MOULDING PACKAGE, Door
	18-6000 744	Clip

★ Indicates use as required.

☐ Indicates parts not listed in any previous parts book.

* Indicates change or addition.

Numerals in parentheses () refer to notes.

Printed in U.S.A.

Prices and specifications subject to change without notice.

REF. NO.	PART NUMBER	DESCRIPTION
3	2196 360-1	MOULDING PACKAGE, Quarter Panel
	20-6000 755	Clip
4	2-2196 298	ORNAMENT PACKAGE, Quarter Panel Moulding
	4-6006 264	Nut
5	2-2196 362	MOULDING PACKAGE, Quarter Panel
	18-3000 788	Clip and Seal
6	2196 418-9	MOULDING PACKAGE, Quarter Panel
	8-1963 070	Seal
	4-151 497	Nut
7	*2-1881 736	REFLECTOR PACKAGE, Quarter Panel Moulding
	*2 ----	Reflector
	*2 ----	Retainer
	*2 ----	Gasket
8	*2196 350-1	MOULDING PACKAGE, Quarter Panel
	1963 182-3	RETAINER
	4-6006 461	Clip
9	*1963 126-7	PANEL, Quarter Panel Finish, PD3-M, PD4-M
	1963 114-5	PANEL, Quarter Panel Finish, PD3-H, PD4-H
10	*2196 296-7	MOULDING PACKAGE, Quarter Panel, PD3-M, PD4-M
	1963 182-3	RETAINER
	4-6000 754	Clip and Seal
	2196 352-3	MOULDING PACKAGE, Quarter Panel, PD3-H, PD4-H
	2-6000 754	Clip and Seal
	2-131 044	Washer
	2-6000 749	Clip
	1963 182-3	RETAINER
	2-159 254	Screw
11	*2196 356-7	MOULDING PACKAGE, Quarter Panel, PD3-H, PD4-H
	16-6000 754	Clip and Seal
	1963 182-3	RETAINER

1960 DODGE MOULDINGS for 4 Door Suburbans and Special 4 Door Suburbans

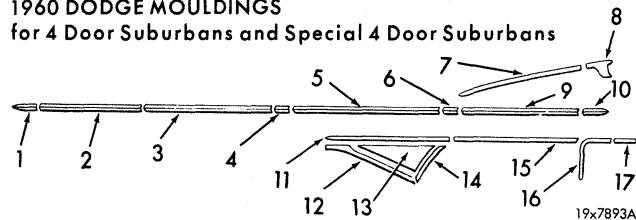

REF. NO.	PART NUMBER	DESCRIPTION
1	2-2196 428	CAP PACKAGE, Front Fender Moulding
	2-6006 143	Clip
	2-446 059	Nut
2	2196 426-7	MOULDING PACKAGE, Front Fender
	10-6000 710	Clip
	2-6006 429	Clip
3	2196 368-9	MOULDING PACKAGE, Front Door
	8-6000 710	Clip

REF. NO.	PART NUMBER	DESCRIPTION
4	2196 370-1	MOULDING PACKAGE, Front Door
	2-6000 780	Clip
	*2165 357	Screw and Washer
5	*2196 372-3	MOULDING PACKAGE, Rear Door, D1, D2
	8-6000 710	Clip
6	*2196 374-5	MOULDING PACKAGE, Rear Door, D1, D2
	2-6000 780	Clip
	*2-2165 357	Screw and Washer
7	2-2196 429	MOULDING PACKAGE, Quarter Panel
	12-6000 788	Clip
8	2196 430-1	MOULDING PACKAGE, Quarter Panel, PD1, PD2
	2-125 591	Screw
	2-151 497	Nut
	2-6006 500	Clip
	2-1961 944	SPACER
	2-187 572	Screw
	2196 432-3	MOULDING PACKAGE, Quarter Panel, PD3, PD4
	*2-125 591	Screw
	*2-151 497	Nut
	2-6006 500	Clip
9	*2196 384-5	MOULDING PACKAGE, Quarter Panel, D1, D2
	12-6000 716	Clip
10	*2-2196 367	MOULDING PACKAGE, Quarter, Panel, D1, D2
	*2-6010 029	Clip
	2-1963 302	RETAINER
	*2-6000 834	Clip
	*2-2165 097	Nut
	2-6000 028	Nut and Seal
11	2196 440-1	MOULDING PACKAGE, Rear Door, PD3, PD4
	8-6000 744	Clip
	2-6000 705	Clip and Bolt
	2-151 497	Nut
12	2196 442-3	MOULDING PACKAGE, Rear Door, PD3, PD4
	2-6006 461	Retainer
	2093 438-9	RETAINER
13	2196 438-9	PLATE PACKAGE, Rear Door Finish, PD3, PD4
	4-145 186	Screw
14	2196 444-5	MOULDING PACKAGE, Rear Door, PD3, PD4
	2-6000 754	Clip and Seal
	2093 438-9	RETAINER
15	2196 436-7	MOULDING PACKAGE, Quarter Panel, PD3, PD4
	14-6006 455	Retainer
16	2196 392-3	MOULDING PACKAGE, Quarter Panel, PD1, PD2
	*4-6000 137	Clip and Bolt
	2-125 978	Screw
17	2196 434-5	MOULDING PACKAGE, Quarter Panel, PD1, PD2
	8-3006 492	Clip

* Indicates use as required.

Numerals in parentheses () refer to notes.

Printed in U.S.A.

⊠ Indicates parts not listed in any previous parts book.

Prices and specifications subject to change without notice.

April 20, 1960 Supersedes Dec. 30, 1959.

* Indicates change or addition.

1960 DESOTO Mouldings for 4 Door Sedans and Special 4 Door Sedans

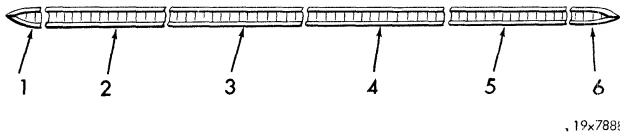

19x788E

1960 CHRYSLER Windsor and Saratoga MOULDINGS for 4 Door Sedans, Special 4 Door Sedans and Special 4 Door Suburbans

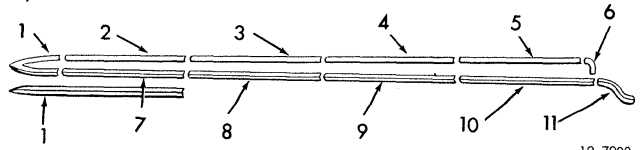

19x7900

REF. NO.	PART NUMBER	DESCRIPTION
1	2196 505-6	CAP PACKAGE, Front Fender Moulding
	2-6013 066	Clip and Bolt
	*2-446 059	Nut
2	2196 507-8	MOULDING PACKAGE, Front Fender
	12-6006 516	Clip
3	2196 536-7	MOULDING PACKAGE, Front Door
	10-6006 453	Clip
4	2196 538-9	MOULDING PACKAGE, Rear Door
	8-6006 453	Clip
	2-6003 459	Retainer and Bolt
	2-271 166	Nut
5	2196 542-3	MOULDING PACKAGE, Quarter Panel
	14-6006 454	Clip
6	2196 530-1	EXTENSION, Quarter Panel Moulding
	2-6006 459	Retainer and Bolt
	2-6013 066	Retainer and Bolt
	*4-6000 028	Nut

1960 DESOTO Mouldings for Special Club Coupes and Convertible Coupes

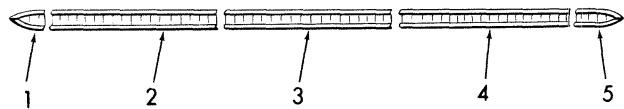

19x788F

REF. NO.	PART NUMBER	DESCRIPTION
1	2196 505-6	CAP PACKAGE, Front Fender Moulding
	2-6013 066	Clip and Bolt
	2-446 059	Nut
2	2196 507-8	MOULDING PACKAGE, Front Fender
	12-6006 516	Clip
3	2196 534-5	MOULDING PACKAGE, Door
	12-6006 453	Clip
4	2196 540-1	MOULDING PACKAGE, Quarter Panel
	20-6006 453	Clip
5	2196 530-1	EXTENSION PACKAGE, Quarter Panel Moulding
	2-6006 459	Retainer and Bolt
	2-6013 066	Retainer and Bolt
	*4-6000 028	Nut

REF. NO.	PART NUMBER	DESCRIPTION
1	2196 552-3	MOULDING PACKAGE, Front Fender, PC1
	2-6006 429	Clip
	2-6010 215	Clip
	2-2196 554	MOULDING PACKAGE, Front Fender, PC2
	4-6006 429	Clip
	2-6010 215	Clip
	2196 559-60	CAP PACKAGE, Front Fender Moulding Spec. Equip.
	2-6010 215	Clip
	2-6000 442	Clip
	2-6006 286	Clip
2	2196 567-8	MOULDING PACKAGE, Front Fender, PC1, Spec. Equip.
	2-6006 490	Clip
	2196 565-6	MOULDING PACKAGE, Front Fender, PC2, Spec. Equip.
	4-6006 470	Clip
3	2-2196 577	MOULDING PACKAGE, Front Door, Spec. Equip.
	10-6006 287	Clip
4	2196 583-4	MOULDING PACKAGE, Rear Door, Spec. Equip.
	8-6006 287	Clip
	2-6010 029	Clip and Bolt
	2-151 497	Nut
5	2196 587-8	MOULDING PACKAGE, Quarter Panel Spec. Equip.
	14-6006 471	Clip
6	2196 591-2	EXTENSION PACKAGE, Quarter Panel Moulding, Spec. Equip.
	2-6006 488	Clip and Bolt
	2-6000 028	Nut
7	2-2196 563	MOULDING PACKAGE, Front Fender, PC1, Spec. Equip.
	2-6006 429	Clip
	2-2196 561	MOULDING PACKAGE, Front Fender, PC2, Spec. Equip.
	4-6006 429	Clip
8	2196 579-80	MOULDING PACKAGE, Front Door
	10-6006 429	Clip
9	2196 585-6	MOULDING PACKAGE, Rear Door
	8-6006 429	Clip
	2-6010 046	Clip and Bolt
	2-151 497	Nut
10	2196 593-4	MOULDING PACKAGE, Quarter Panel
	14-6000 716	Clip

★ Indicates use as required.

□ Indicates parts not listed in any previous parts book.

* Indicates change or addition.

Numerals in parentheses () refer to notes.

REF. NO.	PART NUMBER	DESCRIPTION
11	2196 597-8	EXTENSION PACKAGE, Quarter Panel Moulding, 4D., Sp.4D.
	2093 662-3	EXTENSION, Quarter Panel Moulding, Sp.4D. Sub.
	4-6010 046	Clip and Bolt
	2-6000 745	Clip and Bolt
	6-3000 028	Nut

1960 CHRYSLER PC300F MOULDINGS
for Special Club Coupes and Convertible Coupes

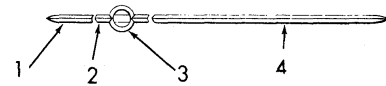

19x7902

1960 CHRYSLER Windsor and Saratoga MOULDINGS
for Special Club Coupes and Convertible Coupes

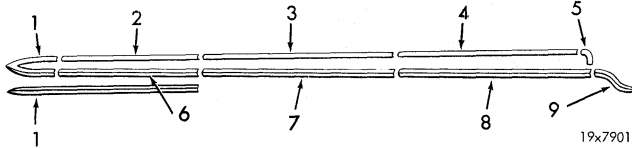

19x7901

REF. NO.	PART NUMBER	DESCRIPTION
1	2196 552-3	MOULDING PACKAGE, Front Fender, PC1
	2-6006 429	Clip
	2-6010 215	Clip
	2-2196 554	MOULDING PACKAGE, Front Fender, PC2
	4-6006 429	Clip
	2-6010 215	Clip
	2196 559-60	CAP PACKAGE, Front Fender Moulding, Spec. Equip.
	2-6010 215	Clip
	2-3000 442	Clip
	2-6006 286	Clip
2	2196 567-8	MOULDING PACKAGE, Front Fender, PC1, Spec. Equip.
	2-6006 470	Clip
	2196 565-6	MOULDING PACKAGE, Front Fender, PC2, Spec. Equip.
	4-6006 470	Clip
3	2-2196 578	MOULDING PACKAGE, Door, Spec. Equip.
	12-6006 287	Clip
4	2196 589-90	MOULDING PACKAGE, Quarter Panel, Spec. Equip.
	20-3006 471	Clip
5	2196 591-2	EXTENSION PACKAGE, Quarter Panel Moulding, Spec. Equip.
	2-3006 488	Clip and Bolt
	2-6000 028	Nut
6	2-2196 563	MOULDING PACKAGE, Front Fender, PC1, Spec. Equip.
	2-6006 429	Clip
	2-2196 561	MOULDING PACKAGE, Front Fender, PC2, Spec. Equip.
	4-6006 429	Clip
7	2196 581-2	MOULDING PACKAGE, Door
	12-6006 429	Clip
8	2196 595-6	MOULDING PACKAGE, Quarter Panel
	20-6000 716	Clip
9	2196 597-8	EXTENSION PACKAGE, Quarter Panel Moulding
	4-6010 046	Clip and Bolt
	2-6000 745	Clip and Bolt
	6-6000 028	Nut

REF. NO.	PART NUMBER	DESCRIPTION
1	2-2196 574	MOULDING PACKAGE, Quarter Panel
	2-6000 716	Clip
	2-6010 002	Clip and Bolt
	2-6000 028	Nut
2	2196 575	BASE PACKAGE, Quarter Panel Medallion
	4-6006 215	Nut and Seal
3	2-1961 141	MEDALLION, Quarter Panel
4	2-2196 576	MOULDING PACKAGE, Quarter Panel
	16-6000 716	Clip

1960 IMPERIAL MOULDINGS
for 4 Door Sedans and Special 4 Door Sedans

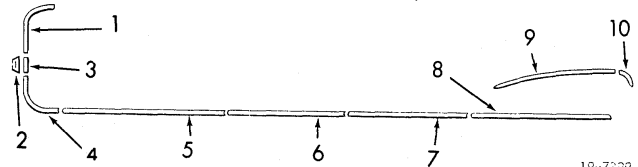

19x7337

REF. NO.	PART NUMBER	DESCRIPTION
1	2196 714-5	MOULDING PACKAGE, Front Fender
	2-273 329	Nut
2	2-1863 120	MEDALLION, Front Fender Moulding
3	2-2196 728	BASE PACKAGE, Front Fender Moulding Medallion
	4- 161 895	Screw
4	2196 726-7	MOULDING PACKAGE, Front Fender
	4-273 329	Nut
5	2196 712-3	MOULDING PACKAGE, Front Fender
	6-6006 448	Clip
	12-6010 213	Clip and Bolt
	12-273 329	Nut
6	2196 675-6	MOULDING PACKAGE, Front Door
	*10-6006 448	Clip
7	2196 743-4	MOULDING PACKAGE, Rear Door
	10-6006 448	Clip
8	2196 745-6	MOULDING PACKAGE, Quarter Panel
	8-6006 448	Clip
	6-6000 709	Clip and Bolt
	6- 273 329	Nut
9	2-2196 679	MOULDING PACKAGE, Quarter Panel
	*12-6006 446	Clip
	*2-6006 521	Retainer

* Indicates use as required.

Numerals in parentheses () refer to notes.

Printed in U.S.A.

⊠ Indicates parts not listed in any previous parts book.

Prices and specifications subject to change without notice.

April 20, 1960 Supersedes Dec. 30, 1959.

* Indicates change or addition.

REF. NO.	PART NUMBER	DESCRIPTION
10	2-2196 832	BASE PACKAGE, Quarter Panel Reflector
	2-6000 028	Nut
	2-1960 060	REFLECTOR, Quarter Panel Base
	2-1960 499	SEAL, Quarter Panel Reflector
	2-2093 307	Nut

1960 IMPERIAL MOULDINGS
for Special Club Coupes and Convertible Coupes

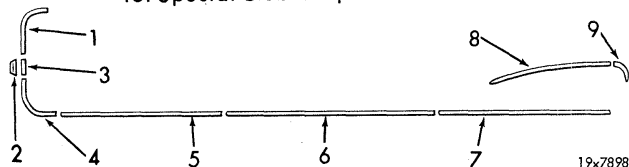

REF. NO.	PART NUMBER	DESCRIPTION
1	2196 714-5	MOULDING PACKAGE, Front Fender
	2-273 329	Nut
2	2-1863 120	MEDALLION, Front Fender Moulding

REF. NO.	PART NUMBER	DESCRIPTION
3	2-2196 728	BASE PACKAGE, Front Fender Moulding Medallion
	4-161 895	Screw
4	2196 726-7	MOULDING PACKAGE, Front Fender
	4-273 329	Nut
5	2196 712-3	MOULDING PACKAGE, Front Fender
	12-6010 213	Clip and Bolt
	12-273 329	Nut
6	2196 677-8	MOULDING PACKAGE, Door
	20-6006 448	Clip
7	2196 747-8	MOULDING PACKAGE, Quarter Panel
	14-6006 448	Clip
	6-6000 709	Retainer and Bolt
	6-273 329	Nut
8	2-2196 679	MOULDING PACKAGE, Quarter Panel
	*12-6006 446	Clip
	*2-6006 521	Retainer
9	2-2196 832	BASE PACKAGE, Quarter Panel Reflector
	2-6000 028	Nut
	2-1960 060	REFLECTOR, Quarter Panel Base
	2-1960 499	SEAL, Quarter Panel Reflector
	2-2093 307	Nut

NOTES

★ Indicates use as required.

□ Indicates parts not listed in any previous parts book.

* Indicates change or addition.

Numerals in parentheses () refer to notes.

Prices and specifications subject to change without notice.

Printed in U.S.A.

CODE	REMARKS	PER CAR	PLYMOUTH	DODGE	DESOTO	CHRYSLER	IMPERIAL
------	---------	---------	----------	-------	--------	----------	----------

GROUP 23 - BODY

23-02-0 ASH RECEIVERS

23-02-1	RECEIVER, Front Seat Back Ash w/Face PLATE	1	2086 611	2086 611	----	----	----
	Complete, use w/Swivel Seat	1	2161 119	2161 119	2161 119	2161 119	----
	Use w/Swivel Seat, w/Face PLATE	1	2161 115	2161 115	2161 115	2161 115	----
	Complete, use w/o Lighter	1	----	----	2080 642	2080 641	----
	Complete, use w/Lighter	1	----	----	----	2080 639	----
	Use w/o Lighter	1	----	----	2080 184	2080 184	----
	Use w/Lighter	1	----	----	----	2080 181	----
23-02-2	RETAINER, Swivel Seat Back Ash Receiver, w/BEZEL	1	2080 784	2080 784	2080 784	2080 784	----
23-02-11	HOUSING, Front Seat Back Ash Receiver	1	1902 375	1902 375	1902 375	----	----
23-02-12	SNUFFER, Front Seat Back Ash Receiver	1	1902 374	1902 374	1902 374	1902 374	----
23-02-18	RECEIVER, Instrument Panel Ash	1	----	1901 938	1901 938	1901 739	1901 826
	Complete	1	1902 337	----	----	1839 704	----
23-02-19	HOUSING, Instrument Panel Ash Receiver	1	1901 751	1901 944	1901 944	----	----
23-02-38	BUMPER, Instrument Panel Ash Receiver	★	----	----	----	----	2080 480
23-02-40	DOOR and HOUSING, Instrument Panel Ash Receiver	1	----	----	----	----	1900 878
23-02-42	HANDLE, Instrument Panel Ash Receiver	1	----	----	----	1698 140	----
23-02-43	SPRING, Instrument Panel Ash Receiver Door						
	Right	1	----	----	----	2080 234	1901 844
	Left	1	----	----	----	----	1901 845
23-02-62	RECEIVER, Rear Quarter Ash Sp.Cl.Cp., Cv.Cp.	2	----	----	----	----	2080 413
23-02-78	RECEIVER, Rear Door Ash	2	----	----	----	----	2080 413
23-02-81	RETAINER, Rear Floor Tunnel Console Ash Receiver Sp.Cl.Cp., Cv.Cp., C3	1	----	----	----	2086 114	----
23-02-89	BEZEL and LID, Rear Door and Quarter Arm Rest Ash Receiver 4 D., Sp. 4 D.						
	Right	1	----	----	----	----	2085 514
	Left	1	----	----	----	----	2085 515
	Sp.Cl.Cp., Cv.Cp.						
	Right	1	----	----	----	----	2080 670
	Left	1	----	----	----	----	2080 671
23-02-105	RECEIVER, Floor Tunnel Console Ash, C3-300						
	Front	1	----	----	----	2161 028	----
	w/Face PLATE, Rear	1	----	----	----	2161 115	----
23-02-107	BEZEL, Rear Floor Tunnel Console Ash Receiver C3-300	1	----	----	----	*2161 035	----
23-02-145	RECEIVER, Third Seat Ash Sub.	1	----	----	----	2086 611	----
23-02-149	BRACKET, Third Seat Ash Receiver Mounting Sub.	1	----	----	----	2080 596	----
23-02-150	HOUSING, Third Seat Ash Receiver Sub.	1	----	----	----	1902 375	----

23-04-0 FLOOR BOARDS

23-04-2	COVER, Steering Column Opening	1	----	----	----	----	*1878 145
23-04-4	SCREW and WASHER, Steering Column Opening Cover	★	----	6000 160	6000 160	----	6000 160
23-04-117	BOLT and RETAINER, Steering Column Opening Cover	3	----	----	----	----	1475 900
23-04-229	PANEL, Spare Tire Cover, except Sub. COVER, Spare Tire (plastic)	1	----	----	1708 248	*1708 248	1708 248
	Sub., 3 Seat	1	2170 087	2170 087	----	2170 087	----
	Sp.4 D. Sub., 3 Seat, C3-H	1	----	----	----	2170 086	----
	Black	1	----	----	----	2170 085	----
	Terra Cotta	1	----	----	----	----	----
	Blue	1	----	----	----	----	----
23-04-241	HOUSING, Fuel Tank Filler Tube, Sub.						
	w/COLLAR	1	1960 502	1960 501	----	1960 500	----
	Upper	1	----	----	----	----	1877 354
	Lower	1	----	----	----	----	1877 353

★ Indicates use as required.

□ Indicates parts not listed in any previous parts book.

* Indicates change or addition.

Printed in U.S.A.

Prices and specifications subject to change without notice.

Dec. 9, 1960 Supersedes April 20, 1960.

1960 PASSENGER CAR PARTS CATALOG

BODY

CODE	REMARKS	PER CAR	PLYMOUTH	DODGE	DESOTO	CHRYSLER	IMPERIAL
23-04-0 FLOOR BOARDS - Cont'd							
23-04-249	SEAL, Fuel Tank Filler Tube 4 D. Sub., Sp. 4 D. Sub. All						
	Housing	1	1833 900	1833 900	----	1833 900	----
	to Door Housing	1	----	----	----	----	1877 516
	Collar	1	----	----	----	----	1877 488
23-04-250	RETAINER, Fuel Tank Filler Tube Seal	1	----	----	----	----	1877 355
23-06-0 GLOVE BOX							
23-06-4	BOX, Glove SCREW	1 ★	2080 550 1901 828	1901 784 1901 828	1901 784 1901 828	1901 793 1901 828	1901 808 1901 828
23-06-10	DOOR, Glove Box	1	21262 116	1901 931	1901 931	1901 734	1839 569
23-06-12	PLATE, Glove Box Door Inner						
	Prime	1	----	----	----	----	1839 568
23-06-13	ARM, Glove Box Door Check SCREW	★	2080 554	1901 790	1901 790	1901 764	----
	Right	★	1901 691	1901 691	1901 691	1901 691	----
	Left	1	----	----	----	----	1902 176
		1	----	----	----	----	1902 177
23-06-14	BUMPER, Glove Box Door	2	729 152	729 152	----	2080 201	2080 480
	Large	1	*1298 930	1298 930	1298 930	----	----
23-06-15	CATCH, Glove Box Door Lock BOLT	1 2	6008 203	2161 217	2161 217	6008 016	2161 469 2161 473
23-06-16	BRACKET, Glove Box Door Lock Catch	1	----	----	----	1685 782	----
23-06-17	FINISH PLATE, Glove Box Door	1	----	1839 734	2161 002	----	----
23-06-21	HINGE, Glove Box Door SCREW, to Door	1 ★	2080 458 1901 691	2161 621 1901 691	2161 621 1901 691	1901 727 1901 691	1902 201 ----
23-06-28	LATCH, Glove Box Door	1	2080 736	----	----	----	----
	w/o Lock	1	1830 415	2080 321	2080 321	1830 415	2086 051
	w/LOCK	1	2080 488	2080 488	2080 488	2080 488	2080 488
23-06-41	GROMMET, Glove Box Door Check Arm	1	----	1902 313	1902 313	----	----
23-06-49	MOULDING, Glove Box Door Horizontal D1, D2 NUT	1 3	----	6008 128	6008 128	----	----
23-06-53	NAME PLATE, Glove Box Door						
	Dodge	1	----	2080 987	----	----	----
	Seneca	1	----	2080 986	----	----	----
	Pioneer	1	----	2080 984	----	----	----
	Phoenix	1	----	2080 985	----	----	----
	NUT	2	----	6008 128	----	----	----
	FireFlite	1	----	----	2161 003	----	----
	Adventurer	1	----	----	2161 004	----	----
	NUT	2	----	----	6008 153	----	----
	Windsor	1	----	----	----	1901 847	----
	Saratoga	1	----	----	----	1901 848	----
	New Yorker	1	----	----	----	1901 849	----
	Chrysler	1	----	----	----	1902 430	----
	NUT	3	----	----	----	6008 153	----
23-06-102	CLIP, Glove Box Door Road Map SCREW	1 2	2080 950 1901 828	----	----	----	----
23-07-0 BRACKETS AND REINFORCEMENTS							
23-07-168	REINFORCEMENT, Instrument Panel Lower	1	----	----	----	----	1839 570
23-07-169	BRACKET, Instrument Panel Lower Rein- forcement to Pillar						
	Right	1	----	----	----	----	2080 652
	Left	1	----	----	----	----	2080 653

★ Indicates use as required.

⊠ Indicates parts not listed in any previous parts book.
Dec. 9, 1960 Supersedes April 20, 1960.

Printed in U.S.A.
Prices and specifications subject to change without notice.

* Indicates change or addition.

CODE	REMARKS	PER CAR	PLYMOUTH	DODGE	DESOTO	CHRYSLER	IMPERIAL
23-08-0 BUMPERS AND STRIKERS							
23-08-12	BUMPER or WEDGE, Door Sp.Cl.Cp., Cv.Cp.	Door	2	989 513	989 513	989 513	989 513
		Body	2	1544 841	1544 841	1544 841	1750 995
	Cl.Sed., 2D. Sub.	Upper	2	2080 201	2080 201	----	----
		Center and Lower	4	1954 393	1954 393	----	----
	4 D., 4 D. Sub.	Front Upper	2	2080 201	2080 201	2080 201	2093 675
		Center	2	1883 740	1883 740	1954 393	1954 393
		Lower	2	1833 740	1883 740	1883 740	2093 675
		Rear Upper and Lower	4	1883 740	1883 740	1883 740	----
	Sp.4D., Sp.4 D.Sub.	Front Upper and Lower	4	1883 740	1883 740	1883 740	1883 740
		Rear Upper and Lower	2	1883 740	1883 740	1883 740	1883 740
	Sp.Cl.Cp., Cv.Cp.	Upper	2	1954 393	1954 393	1954 393	1954 393
		Lower	2	1954 393	1954 393	1954 397	1954 397
	Sp.Cl.Cp., Cv.Cp.		4	----	----	----	2093 950
23-08-13	STOP, Front Door Bumper 4 D., Sp. 4 D.	Chrome	4	----	----	----	2080 982
	SCREW		4	----	----	----	161 378
23-08-54	SPACER, Door Lock Striker						
		Thin	★	1954 717	1954 717	1954 717	1954 717
23-08-60	STRIKER, Door Lock	Right	★	1954 234	1954 234	1954 234	1954 234
		Left	★	1954 235	1954 235	1954 235	1954 235
23-08-75	PLATE, Door Lockstriker Tapping		★	1952 214	1952 214	1952 214	1952 214
23-09-0 GLASS CHANNELS							
23-09-2	ROLLER, Door Glass Lower Channel 4 D., 4 D.Sub.	Rear, Single Groove	★	1697 607	1697 607	1697 607	1697 607
		Single Groove	★	----	----	----	1750 490
	Sp. 4 D.	Rear Door, Electric	6	----	----	----	2094 112
23-09-9	CHANNEL, Quarter Window Glass Lower Cl.Sed., 2D. Sub.	Right	1	1950 560	1950 560	----	----
		Left	1	1950 561	1950 561	----	----
	Sp.Cl.Cp., Cv.Cp.	Right	1	----	----	----	1691 086
		Left	1	----	----	----	1691 087
23-09-10	ROLLER, Quarter Window Glass Lower Channel						
	Cv.Cp., Cl.Sed., 2D. Sub.	Single Groove	2	1697 607	1697 607	----	1697 607
23-09-13	NUT, Quarter Window Rear Track Roller Sleeve						
	Cv. Cp.		2	1909 708	1909 708	----	1909 708
23-09-16	GUIDE, Quarter Window Glass, w/BRACKET Sp.Cl.Cp.	w/HOLES, Right	1	*1964 018	*1964 018	----	----
		Left	1	1964 019	1964 019	----	----
		w/SLOTS, Right	1	⊠2166 034	⊠2166 034	----	----
		Left	1	⊠2166 035	⊠2166 035	----	----
23-09-17	SLIDE, Quarter Window Lower Channel Guide, Nylon Sp.Cl.Cp., Cv.Cp.						
		1 Piece Double Groove Roller	★	1883 819	1883 819	1883 819	1883 819
		5 Piece Double Groove Roller	★	2165 992	2165 992	2165 992	2165 992
	Sp.Cl.Cp., Cv.Cp.		8	----	----	----	1690 950
	Rear Door Window Lower Channel Guide						
		1 Piece Double Groove Roller	6	1883 819	1883 819	1883 819	1883 819
		5 Piece Double Groove Roller	6	2165 992	2165 992	2165 992	2165 992
23-09-47	SUPPORT, Front Door Glass Rear Run Channel Sp. 4 D., Sp. 4 D.Sub., Sp.Cl.Cp., Cv.Cp.						
		Upper	2	1963 732	1963 732	1963 732	1963 732
		Lower	2	1954 446	1954 446	1954 446	1954 446
23-09-51	CHANNEL, Front Door Window Glass Rear Run Sp. 4 D., Sp. 4 D.Sub., Sp.Cl.Cp., Cv.Cp., w/RUN, Right						
		Left	1	*1950 812	*1950 812	*1950 812	*1950 812
		Left	1	1950 813	1950 813	1950 813	1950 813
	Except 4 D.	Right	1	----	----	----	*1961 382
		Left	1	----	----	----	*1961 383
	4 D.	Right	1	----	----	----	*1750 614
		Left	1	----	----	----	*1750 615

★ Indicates use as required.

⊠ Indicates parts not listed in any previous parts book.

* Indicates change or addition.

1960 PASSENGER CAR PARTS CATALOG

CODE	REMARKS	PER CAR	PLYMOUTH	DODGE	DESOTO	CHRYSLER	IMPERIAL
23-09-0 GLASS CHANNELS-Cont'd							
23-09-52	CHANNEL, Front Door Window Glass Lower Cl. Sed., 2 D. Sub.	Right Left	1 1	2165 714 2165 715	2165 714 2165 715	---- ----	---- ----
	4 D., 4 D. Sub.	Right Left	1 1	2165 712 2165 713	2165 712 2165 713	2165 712 2165 713	1750 816 1750 817
	Sp. 4 D.	Right Left	1 1	---- ----	---- ----	---- ----	*1750 578 *1750 579
	Sp. Cl. Cp., Cv. Cp.	Right Left	1 1	---- ----	---- ----	---- ----	1751 056 1751 057
23-09-56	CHANNEL, Rear Door Window Glass Run 4 D.	Front, Right Left	1 1	---- ----	---- ----	---- ----	1961 390 1961 391
	Sp. 4 D.	Front, Right Left	1 1	---- ----	---- ----	---- ----	1961 378 1961 379
		Rear, Right Left	1 1	---- ----	---- ----	---- ----	1961 380 1961 381
23-09-58	CHANNEL, Rear Door Window Glass Lower 4 D., D3, D4	Right Left	1 1	1950 582 1950 583	1950 582 1950 583	1950 648 1950 649	1950 648 1950 649
	4 D. Sub.	Right Left	1 1	1950 648 1950 649	1950 648 1950 649	---- ----	---- ----
	4 D., D1, D2	Right Left	1 1	---- ----	1950 648 1950 649	---- ----	---- ----
	Sp. 4 D.	Right Left	1 1	---- ----	---- ----	---- ----	1692 152 1692 153
23-09-67	CHANNEL, Tailgate Glass Run Sub.	Side Lower, Right Left	1 1	1960 008 1960 009	1960 008 1960 009	---- ----	1960 008 1960 009
23-09-75	CHANNEL, Quarter Window Guide Sp. Cl. Cp., Cv. Cp.	Front, Right Left Rear, Right Left	1 1 1 1	---- ---- ---- ----	---- ---- ---- ----	---- ---- ---- ----	1961 392 1961 393 1961 394 1961 395
23-10-0 DOOR CHECK							
23-10-1	ARM, Rear Door Check		2	----	----	----	1860 829
23-10-2	BRACKET, Rear Door Check Arm		2	----	----	----	1750 686
23-10-17	GUIDE, Rear Door Check Arm		2	----	----	----	1476 900
23-11-0 DOORS							
23-11-1	SHELL, Front Door Cl. Sed., 2 D. Sub.	Right Left	1 1	1964 122 1964 123	1964 122 1964 123	---- ----	---- ----
	4 D., 4 D. Sub.	Right Left	1 1	1964 118 1964 119	1964 118 1964 119	1952 508 1952 509	1952 508 1952 509
	Sp. 4 D., Sp. 4 D. Sub.	Right Left	1 1	2165 326 2165 327	2165 326 2165 327	2165 338 2165 339	2165 338 2165 339
	Sp. Cl. Cp., Cv. Cp.	Right Left	1 1	1964 124 1964 125	1964 124 1964 125	1952 516 1952 517	1952 516 1952 517
23-11-2	DOOR, Front, Trimmed, Includes HARDWARE and GLASS. All Codes.						
NOTE: Door assemblies complete, will no longer be listed by part number in the parts books. Door assemblies complete will be available during the production run of the car model and will be furnished on special order only. The vehicle SERIAL NUMBER must be noted on the order.							
23-11-3	SHELL, Rear Door 4 D. Sub.	Right Left	1 1	1964 130 1964 131	1964 130 1964 131	---- ----	---- ----
	4 D., D1, D2	Right Left	1 1	1964 126 1964 127	1964 138 1964 139	1952 510 1952 511	1952 510 1952 511
	Sp. 4 D., D1, D2	Right Left	1 1	1964 128 1964 129	1964 140 1964 141	1952 514 1952 515	1952 514 1952 515

★ Indicates use as required.

☐ Indicates parts not listed in any previous parts book.
Dec. 9, 1960 Supersedes April 20, 1960.

Printed in U.S.A.
Prices and specifications subject to change without notice.

* Indicates change or addition.

CODE	REMARKS	PER CAR	PLYMOUTH	DODGE	DESOTO	CHRYSLER	IMPERIAL
23-11-0 DOORS - Cont'd							
23-11-3	SHELL - Cont'd 4 D., D3, D4	Right Left	1 1	1964 132 1964 133	---	---	---
	Sp. 4 D.Sub.	Right Left	1 1	1964 136 1964 137	---	1952 514 1952 515	---
	Sp. 4 D., D3, D4	Right Left	1 1	1964 134 1964 135	---	---	---
23-11-4	DOOR, Rear, Trimmed, Includes HARDWARE and GLASS. All Codes.						
NOTE: Door assemblies complete, will no longer be listed by part number in the parts books. Door assemblies complete will be available during the production run of the car model and will be furnished on special order only. The vehicle SERIAL NUMBER must be noted on the order.							
23-11-23	ORNAMENT PACKAGE, Rear Door						
	Sub.		2	2084 547	---	---	---
	CLIP		4	6000 752	---	---	---
	4 D., Sp. 4 D., D3, D4		2	2196 109	---	---	---
	NUT		4	6006 264	---	---	---
23-13-0 SAFE-T-MATIC DOOR LOCKS							
NOTE: See Illustration in Front of Group							
23-14-0 DOOR REGULATORS AND REMOTE CONTROL HANDLES							
23-14-7	HANDLE, Rear Door Outside Assist Taxi	Right Left	1 1	2165 276 2165 277	---	---	---
	RIVET		8	2165 341	---	---	---
23-14-10	HANDLE, Door Outside	Front, Right Left Rear, Right Left	1 1 1 1	1961 600 1961 601 1961 606 1961 607	1961 600 1961 601 1961 606 1961 607	1961 600 1961 601 1961 606 1961 607	1961 600 1961 601 1961 606 1961 607
	NUT		★	151 497	151 497	151 497	151 497
23-14-18	HANDLE, Door Window Regulator w/ESCUTCHEON		★	1952 818	1952 819	---	---
23-14-19	ESCUTCHEON, Doors and Quarter Window Regulator Handle ESCUTCHEON, Quarter Window Regulator Handle		★	*1954 124	2192 685	2192 685	2192 685
23-14-21	Sp. Cl. Cp., Cv. Cp., Cl. Sed. 1/4" Thick SPRING, Regulator and Remote Control Handle		2	2192 685	---	---	---
23-14-23	CLIP, Regulator and Remote Control Handle		★	1602 532	1602 532	1602 532	1602 532
23-14-24	SPACER, Regulator and Remote Control Plastic		★	1954 128	1954 128	1900 872	1900 872
	1 23/64" O.D. x 1 7/32 I.D. x 1/4"		★	2165 667	---	---	---
23-14-25	COVER, Door Remote Control Handle D3, D4		★	1952 955	1952 955	---	---
23-14-27	HANDLE, Door Remote Control C1, C2	Right Left	★ ★	1954 568 1954 569	1954 570 1954 571	2086 674 2086 675	2086 674 2086 675
	C3	Right Left	★ ★	---	---	1900 860 1900 861	1900 856 1900 857
	SCREW on Handle		★	---	---	6008 191	6008 191
23-14-39	HANDLE, Front Door Vent Wing						
NOTE: See Part Type Code 23-14-53.							
23-14-46	WASHER, Front Door Vent Wing Handle Shaft		2	6000 110	6000 110	6000 110	6000 110

★ Indicates use as required.

☐ Indicates parts not listed in any previous parts book.

* Indicates change or addition.

CODE	REMARKS	PER CAR	PLYMOUTH	DODGE	DESOTO	CHRYSLER	IMPERIAL
23-14-0 DOOR REGULATORS AND REMOTE CONTROL HANDLES - Cont'd							
23-14-47	CATCH, Front Door Vent Wing Handle 4 D.	Right 1 Left 1	----	----	----	----	2094 186 2094 187
	Except 4 D.	Right 1 Left 1	----	----	----	----	2093 828 2093 829
23-14-51	GROMMET, Door Remote Control Handle, w/CLIP C3	★	----	----	----	2085 899	2085 862
23-14-52	PIN, Door Vent Wing Handle to Shaft	2	6000 116	6000 116	6000 116	6000 116	6000 116
23-14-53	HANDLE PACKAGE, Front Door Vent Wing	Right 1 Left 1	1954 110 1954 111	1954 110 1954 111	1954 110 1954 111	1954 110 1954 111	1954 110 1954 111
23-14-79	HANDLE, Quarter Window Regulator Cl. Sed.	2	1954 540	1954 541	----	----	----
	Sp. Cl. Cp., Cv. Cp., 2 D. Sub.	2	1952 818	1952 819	----	----	----
	Sp. Cl. Cp., Cv. Cp. w/ESCUTCHEON	2	----	----	2085 252	2085 252	2085 252
23-14-153	BUMPER, Door Outside Handle	★	1651 493	1651 493	1651 493	1651 493	1651 493
	Center	★	*1707 384	*1707 384	*1707 384	*1707 384	*1707 384
23-15-0 DOOR HINGE							
23-15-1	HINGE, Door Upper, w/Integral CHECK	Front, Right 1 Left 1	1882 028 1882 029	1882 028 1882 029	1882 028 1882 029	1882 028 1882 029	1651 394 1651 395
	Sp. 4 D., Sp. 4 D. Sub.	Rear, Right 1 Left 1	1882 400 1882 401	1882 400 1882 401	1950 604 1950 605	1950 604 1950 605	1651 400 1750 565
	4 D., 4 D. Sub.	Rear, Right 1 Left 1	1950 610 1950 611	1950 610 1950 611	1884 448 1884 449	1884 448 1884 449	1651 400 1750 565
23-15-3	HINGE, Door Lower	Front, Right 1 Left 1	*1882 048 1882 049	*1882 048 1882 049	*1882 048 1882 049	*1882 048 1882 049	*2094 238 2094 239
	4 D., 4 D. Sub.	Rear, Right 1 Left 1	2166 452 2166 453	2166 452 2166 453	2166 452 2166 453	2166 452 2166 453	1651 400 1750 565
	Sp. 4 D., Sp. 4 D. Sub., w/CHECK	Rear, Right 1 Left 1	2166 466 2166 467	2166 466 2166 467	2166 466 2166 467	2166 466 2166 467	1651 400 1750 565
23-15-6	ROLLER, Door Hinge Integral Check	Front Upper 2 Rear Lower 2	1883 802 1882 967	1883 802 1882 967	1883 802 1882 967	1883 802 1882 967	---- ----
23-15-7	SHIM, Rear Door Upper Hinge Sp. 4 D., Sp. 4 D. Sub.	Thin ★ Thin ★	1950 670 ----	1950 670 ----	---- *1909 421	---- *1909 421	---- ----
23-15-9	PIN, Door Hinge Integral Check	Upper ★ Lower ★	1882 054 1882 964	1882 054 1882 964	1882 054 1882 964	1882 054 1882 964	---- ----
	PIN, Door Hinge	Upper ★ Lower ★	1882 053 1882 965	1882 053 1882 965	1882 053 1882 965	1882 053 1882 965	---- ----
23-15-10	SCREW and WASHER, Door Hinge	★	1244 818	1244 818	1244 818	1244 818	1244 818
23-15-11	RING, Door Hinge Integral Check Roller Retainer	Front 2 Rear 2	1884 405 1882 961	1884 405 1882 961	1884 405 1882 961	1884 405 1882 961	---- ----
23-15-13	PLATE, Front Pillar Door Hinge Tapping	4	----	----	----	----	6006 086
23-15-14	SPRING, Door Hinge Integral Check Pin	Upper ★ Lower ★	1882 055 1882 963	1882 055 1882 963	1882 055 1882 963	1882 055 1882 963	---- ----
23-15-17	SPACER, Front Door Upper Hinge or Sleeve	4	1909 975	1909 975	1909 975	1909 975	----
23-15-21	SPACER, Rear Door Hinge Integral Check Pin RETAINER, Center Pillar Rear Door Hinge Tapping Plate	2	1950 559	1950 559	1950 559	1950 559	----
		Upper, Right 1 Left 1	----	----	----	----	1750 602 1750 603
		Lower 2	----	----	----	----	1750 484
23-15-22	GROMMET, Front Door Hinge SEAL, Door Hinge	Lower 2 ★	1758 813 ----	1758 813 ----	1758 813 ----	1758 813 ----	---- 1961 262

★ Indicates use as required.

□ Indicates parts not listed in any previous parts book.
Dec. 9, 1960 Supersedes April 20, 1960.Printed in U.S.A.
Prices and specifications subject to change without notice.

* Indicates change or addition.

CODE	REMARKS	PER CAR	PLYMOUTH	DODGE	DESOTO	CHRYSLER	IMPERIAL
23-17-0 LOCK CYLINDER AND KEYS							
NOTE: For Glove Box See Part Type Code 23-06-28.							
23-17-2	CYLINDER and KEY, Door and Ignition Lock						
	CJ Series	1	⊖2161 503	⊖2161 503	⊖2161 503	⊖2161 503	⊖2161 503
	Taxi CJ Series	1	2080 227	----	----	----	----
	CYLINDER and KEYS, Door, Ignition and Electric Tailgate Lock						
	Sp. 4 D. Sub. CJ Series	1	----	----	----	1838 985	----
23-17-4	PACKAGE, Deck Lid and Glove Box Door Lock Cylinder and Keys						
	Taxi	1	2086 052	----	----	----	----
23-17-5	CYLINDER and KEYS, Deck Lid Lock	1	2086 049	2086 049	2086 049	2086 049	2086 050
23-17-9	GASKET, Deck Lid Lock Cylinder	1	1883 896	1883 896	1883 896	1883 896	----
23-17-10	RETAINER, Deck Lid Lock Cylinder	1	2080 575	2080 575	2080 575	2080 575	----
23-17-11	SPRING, Deck Lid Lock Cylinder Cover	1	----	----	----	----	1961 074
23-17-13	COVER, Deck Lid Lock Cylinder, w/MEDALLION	1	----	----	----	----	1960 544
23-17-18	RETAINER, Rear Floor Pan Cover Lock Cylinder						
	Sub.	1	1866 686	1866 686	----	1866 686	----
23-17-24	CYLINDER and KEYS, Door Lock (consists of 2 Cylinders and 2 Keys)	1	2086 048	2086 048	2086 048	2086 048	2086 048
23-17-25	KEY, Door and Ignition Lock Cylinder Blank						
	CJ Series	★	1649 628	1649 628	1649 628	1649 628	1698 845
23-17-49	CYLINDER and KEYS, Tailgate Lock Sub.						
	Manual	1	⊖2161 599	⊖2161 599	----	⊖2161 599	----
	Electric	1	1972 966	1972 966	----	1972 966	----
23-17-51	GASKET, Electric Tailgate Lock Cylinder						
	Sub.	1	1819 316	1819 316	----	1819 316	----
23-17-52	RETAINER, Electric Tailgate Lock Cylinder						
	Sub.	1	1819 317	1819 317	----	1819 317	----
23-17-66	KEY, Deck Lid and Glove Box Lock Cylinder Blank	2	----	----	----	----	1520 798
23-17-72	CYLINDER and KEYS, Tirewell Cover Lock						
	Sub.	1	1830 044	1830 044	----	1830 044	----
23-18-0 DOOR LOCKS AND REMOTE CONTROLS							
23-18-5	LOCK, Door						
	Front, Right	1	1954 056	1954 056	1954 056	1954 056	1961 744
	Left	1	1954 057	1954 057	1954 057	1954 057	1961 745
	Rear, Right	1	1954 058	1954 058	1954 058	1954 058	1961 746
	Left	1	1954 059	1954 059	1954 059	1954 059	1961 747
23-18-11	LINK, Rear Door Lock Remote Control	2	----	----	----	----	*1961 717
23-18-13	REMOTE CONTROL, Door Lock, w/LINK						
	Sp. Cl. Cp., Cv. Cp., Cl. Sed., 2 D. Sub., C1, C2						
	Right	1	1964 836	1964 836	1964 836	1964 836	1961 750
	Left	1	1964 837	1964 837	1964 837	1964 837	1961 751
	4 D., Sp. 4 D., 4 D. Sub., Sp. 4 D. Sub., C1, C2						
	Front, Right	1	1964 834	1964 834	1964 834	1964 834	----
	Left	1	1964 835	1964 835	1964 835	1964 835	----
	4 D., Sp. 4 D., D1, D2, C1, C2						
	Rear, Right	1	1964 784	1964 782	1964 782	1964 782	----
	Left	1	1964 785	1964 783	1964 783	1964 783	----
	4 D., Sp. 4 D., D3, D4, C3						
	Rear, Right	1	----	1964 784	----	2165 232	----
	Left	1	----	1964 785	----	2165 233	----
	4 D. Sub., Sp. 4 D. Sub., D1, D2, C3						
	Rear, Right	1	----	1964 782	----	2165 232	----
	Left	1	----	1964 783	----	2165 233	----
	4 D., Sp. 4 D., Sp. 4 D. Sub., C3						
	Front, Right	1	----	----	----	2165 224	1961 748
	Left	1	----	----	----	2165 225	1961 749
	Sp. Cl. Cp., Cv. Cp.						
	Right	1	----	----	----	2165 226	----
	Left	1	----	----	----	2165 227	----
	REMOTE CONTROL, Door Lock						
	Rear, Right	1	----	----	----	----	1961 704
	Left	1	----	----	----	----	1961 705

★ Indicates use as required.

⊖ Indicates parts not listed in any previous parts book.

* Indicates change or addition.

1960 PASSENGER CAR PARTS CATALOG

CODE	REMARKS	PER CAR	PLYMOUTH	DODGE	DESOTO	CHRYSLER	IMPERIAL
23-18-0 DOOR LOCKS AND REMOTE CONTROLS - Cont'd							
23-18-14	SCREW and WASHER, Door Remote Control	4	----	----	----	----	1277 755
23-18-20	LINK, Door Outside Handle to Lock						
	Front	2	1963 638	1963 638	1963 639	1963 639	----
	4 D., Sp. 4 D., D3, D4	2	1954 909	1954 909	1954 911	1954 911	1961 736
	4 D.Sub., Sp. 4 D.Sub.	2	1954 910	1954 910	1954 911	1954 911	----
	4 D., Sp. 4 D., D1, D2	2	----	1954 910	----	----	----
	4 D., Sp. 4 D.	2	----	----	----	----	1961 752
	Sp.Cl.Cp., Cv.Cp.	2	----	----	----	----	1961 753
23-18-21	SPRING, Door Lock Remote Control Lever	★	849 517	849 517	849 517	849 517	849 517
23-18-23	CLIP, Door Lock Remote Control Link	★	----	----	6000 094	6000 094	6000 394
23-18-25	CONTROL, Rear Door Lock Locking, w/LINK						
	4 D., Sp. 4 D., D3, D4	Right	1 1884 486	1884 486	----	----	----
		Left	1 1884 487	1884 487	----	----	----
	Sub.	Right	1 1884 488	----	----	----	----
		Left	1 1884 489	----	----	----	----
	D1, D2	Right	1 ----	1884 488	1884 488	1884 488	1961 724
		Left	1 ----	1884 489	1884 489	1884 489	1961 725
23-18-26	LINK or ROD, Front Door Lock to Lock Cylinder						
	Except Sp.Cl.Cp., Cv.Cp.	Right	1 1954 818	1954 818	1954 830	1954 830	1961 862
		Left	1 1954 819	1954 819	1954 831	1954 831	2093 412
	Sp.Cl.Cp., Cv.Cp.	Right	1 1954 818	1954 818	1954 830	1954 830	1961 863
		Left	1 1954 819	1954 819	1954 831	1954 831	2093 413
23-18-27	KNOB, Rear Door Lock Locking Control	2	1952 601	1952 601	1952 601	1952 601	1952 601
	SCREW	2	158 414	158 414	158 414	158 414	158 414
23-18-28	SPRING, Rear Door Lock Locking Control						
		Right	1 1458 246	1458 246	1458 246	1458 246	----
		Left	1 1458 247	1458 247	1458 247	1458 247	----
23-18-29	RETAINER, Door Outside Handle to Lock	★	1954 851	1954 851	1954 851	1954 851	1954 851
	CLIP, Front Door Lock Cylinder to Locking Lever	2	6000 551	6000 551	6000 551	6000 551	6000 551
23-18-37	WASHER, Rear Door Lock Locking Control Knob	2	1952 603	1952 603	1952 603	1952 603	1952 603
23-18-40	ANTI-RATTLER, Door Remote Control Link	★	1952 778	1952 778	1952 778	1952 778	----
23-18-42	CLIP, Rear Door Remote Control and Lock Link Anti-Rattle	4	----	----	----	----	E6006 506
23-18-45	CLIP, Door Lock Release Lever Ball	★	----	----	----	----	1954 851
23-18-74	NUT, Door Lock Remote Control	★	----	----	6000 437	6000 437	----
23-18-103	SWITCH, Electric Door Lock	2	----	----	----	----	2096 398
23-18-104	SPRING, Electric Door Lock Switch and Bezel Retaining	8	----	----	----	----	*2096 169
23-18-106	RELAY, Electric Door Lock	1	----	----	----	----	2198 105
23-18-107	LINK, Electric Door Lock Solenoid to Lock						
	4 D., Sp. 4 D.	Front	2 ----	----	----	----	1972 952
		Rear	2 ----	----	----	----	1972 953
	Sp.Cl.Cp., Cv.Cp.	2	----	----	----	----	1972 954
23-18-109	CLIP, Door Lock Solenoid to Lock Link	Right	★ ----	----	----	----	6015 106
		Left	★ ----	----	----	----	6015 107
23-18-111	CONNECTOR, Electric Door Lock Switch Single	2	----	----	----	----	2096 905
23-18-112	BREAKER, Electric Door Lock Circuit	1	----	----	----	----	*1566 038
23-18-115	SOLENOID, Electric Door Lock, w/BRACKET						
	4 D., Sp. 4 D.	Front	2 ----	----	----	----	1972 940
	SCREW and WASHER	4	----	----	----	----	*2096 129
		Rear, Right	1 ----	----	----	----	1972 938
		Left	1 ----	----	----	----	1972 939
	SCREW and WASHER	4	----	----	----	----	E6015 005
	Sp.Cl.Cp., Cv.Cp.	Right	1 ----	----	----	----	1972 942
		Left	1 ----	----	----	----	1972 943
	SCREW and WASHER	4	----	----	----	----	E6015 005
23-18-120	PACKAGE, Electric Door Lock Solenoid Terminal and Insulator	★	----	----	----	----	1843 226

★ Indicates use as required.

E Indicates parts not listed in any previous parts book.
Dec. 9, 1960 Supersedes April 20, 1960.

CODE	REMARKS	PER CAR	PLYMOUTH	DODGE	DESOTO	CHRYSLER	IMPERIAL
23-19-0 DECK LID							
23-19-8	LID, Deck						
	D1, D2	1	1882 196	1882 197	2165 686	2165 686	1877 584
	D3, D4	1	----	1963 664	----	----	----
	All w/Spare Tire PANEL	1	----	----	----	1954 447	1877 585
23-19-11	LIFT PACKAGE, Deck Lid	1	----	----	2196 515	2196 515	----
	NUT and SEAL	2	----	----	6006 403	6006 403	----
	All	1	----	----	----	----	2196 806
	NUT	2	----	----	----	----	151 497
	Use w/False Spare Wheel	1	----	----	----	----	2196 805
	NUT	2	----	----	----	----	151 497
23-19-21	PLUG, Deck Lid Inside Panel Drain Hole						
	Small	2	1878 752	1878 752	1878 752	1878 752	----
	Large	2	----	----	1882 735	1882 735	----
23-19-22	GASKET, Deck Lid Lift	1	----	----	----	----	1960 546
	Use w/False Spare Wheel	1	----	----	----	----	1877 749
23-19-45	RING or MOULDING PACKAGE, Deck Lid						
	Spare Tire Cover	1	----	----	----	2196 663	----
	CLIP and BOLT	6	----	----	----	6006 428	----
	NUT	6	----	----	----	151 497	----
	Ring	1	----	----	----	----	2196 493
	NUT and SEAL	6	----	----	----	----	6000 490
		1	----	----	----	----	2196 494
	RETAINER and BOLT	8	----	----	----	----	6006 520
	NUT and SEAL	8	----	----	----	----	----
23-19-52	WELT, Deck Lid Spare Tire Cover	1	2165 356	----	----	----	----
23-19-53	MEDALLION, Deck Lid Spare Tire Cover	1	1963 527	----	----	----	1877 699
23-19-55	PANEL, Deck Lid Spare Tire Cover	1	1963 461	----	----	----	----
	NUT and WASHER	2	6010 007	----	----	----	----
23-19-57	INSERT or ORNAMENT, Deck Lid Spare Tire Cover	1	1963 478	----	----	----	----
	Except C3-300 Pkg.	1	----	----	----	2196 662	----
	NUT	4	----	----	----	151 497	----
	C3-300 Pkg.	1	----	----	----	2196 661	----
	NUT	4	----	----	----	151 497	----
23-19-58	GASKET, Deck Lid Spare Tire Cover						
	Medallion Retainer Ring	1	----	----	----	----	2094 658
23-19-60	TUBE, Deck Lid Spare Tire Ornament Drain	1	----	----	----	1961 489	----
23-19-61	RETAINER, Deck Lid Spare Tire Cover, w/STUDS	1	1963 528	----	----	----	----
23-19-63	BUMPER, Deck Lid	2	1954 763	1954 764	----	----	----
	Lower	1	----	----	2094 759	2094 759	----
	All	2	----	----	----	----	1960 624
	Upper Corner	2	----	----	----	----	1961 737
		2	----	----	----	----	1960 714
23-19-64	REFLECTOR, Deck Lid Spare Tire Cover						
	Medallion	1	----	----	----	----	2093 718
23-19-70	CATCH, Deck Lid Lock	1	1867 661	1867 661	1867 661	1867 661	1867 661
23-19-74	SUPPORT, Deck Lid Lower Panel Lock Striker	1	1960 784	1960 785	1960 098	1960 098	1960 149
23-19-75	PLATE or REINFORCEMENT, Deck Lid Lock	1	----	----	1960 486	1960 486	1960 560
23-19-76	BRACKET, Deck Lid Hinge Support to Wheel House						
	except Cv. Cp. Upper	2	----	----	----	----	1750 991
	Cv. Cp. Right	1	----	----	----	----	1751 130
	Left	1	----	----	----	----	1751 131
23-19-82	SUPPORT, Deck Lid Hinge Body Bracket						
	except Cv. Cp. Upper, Right	1	1909 410	1909 410	----	----	----
	Left	1	1909 411	1909 411	----	----	----
	Lower, Right	1	1884 630	1884 630	----	----	----
	Left	1	1884 631	1884 631	----	----	----
	Upper, Right	1	⊕2165 636	⊕2165 636	----	⊕2165 636	----
	Left	1	⊕2165 637	⊕2165 637	----	⊕2165 637	----
	Lower, Right	1	1950 518	1884 632	----	1909 548	----
	Left	1	1950 519	1884 633	----	1909 549	----

★ Indicates use as required.

⊕ Indicates parts not listed in any previous parts book.

* Indicates change or addition.

CODE	REMARKS	PER CAR	PLYMOUTH	DODGE	DESOTO	CHRYSLER	IMPERIAL
23-19-0 DECK LID - Cont'd							
23-19-82	SUPPORT - Cont'd Except Cv.Cp.	Right 1 Left 1 Cv. Cp. Right 1 Left 1	----	----	----	----	1961 078 1961 079 1961 080 1961 081
23-19-84	HINGE, Deck Lid except Cv.Cp.	Right 1 Left 1 Cv. Cp., D2 Right 1 Left 1 Cv.Cp., D4 Right 1 Left 1 All 2	1884 620 1884 621 1909 308 1909 309 1909 308 1909 309 ----	1884 620 1884 621 2165 570 2165 571 1909 308 1909 309 ----	1884 620 1884 621 ---- 2165 570 2165 571 ---- ----	1884 620 1884 621 2165 570 2165 571 ---- ---- ----	---- ---- ---- ---- ---- ---- 2093 530
23-19-85	PIN, Deck Lid Hinge	2	----	----	----	----	1691 899
23-19-89	BOLT Deck Lid Link to Arm Shoulder SCREW and WASHER, Deck Lid Hinge SCREW and WASHER, Deck Lid Hinge Bracket or Support to Deck Lid	2 2 4 ★	----	2165 408 2165 245	2165 408 2165 245	2165 408 2165 245	2093 422 2165 408 6006 522
23-19-92	SPRING, Deck Lid Hinge Cv.Cp.	2	1909 678	1909 678	----	1909 678	----
23-19-105	LOCK, Deck Lid	1	1843 920	1843 920	1961 038	1961 038	1961 057
23-19-114	NAME PLATE PACKAGE, Deck Lid	Plymouth 1 3	2196 118 6000 037	----	----	----	----
	D1, D2 CLIP	Letter, D 2	----	2196 258	----	----	----
	CLIP	4	----	6010 174	----	----	----
	NUT and SEAL	4	----	6000 490	----	----	----
		O 1	----	2196 259	----	----	----
	CLIP	2	----	6010 174	----	----	----
	NUT and SEAL	2	----	6000 490	----	----	----
		G 1	----	2196 260	----	----	----
	CLIP	2	----	6010 174	----	----	----
	NUT and SEAL	2	----	6000 490	----	----	----
		E 1	----	2196 261	----	----	----
	CLIP	2	----	6010 174	----	----	----
	NUT and SEAL	2	----	6000 490	----	----	----
	D3, D4	Dodge 1	----	2196 108	----	----	----
	NUT and SEAL	4	----	6000 490	----	----	----
	All	Letter, D 1	----	----	2196 509	----	----
	NUT	2	----	----	6000 490	----	----
		E 1	----	----	2196 510	----	----
	NUT	2	----	----	6000 490	----	----
		S 1	----	----	2196 511	----	----
	NUT	2	----	----	6000 490	----	----
		O 2	----	----	2196 512	----	----
	NUT	4	----	----	6000 490	----	----
		T 1	----	----	2196 513	----	----
	NUT	2	----	----	6000 490	----	----
		Le 1	----	----	----	----	2196 484
	NUT and SEAL	2	----	----	----	----	6000 490
		Baron 1	----	----	----	----	2196 485
	NUT and SEAL	3	----	----	----	----	6000 490
	MEDALLION or ORNAMENT PACKAGE, Deck Lid	500 1	----	2196 107	----	----	----
	NUT and SEAL	2	----	6000 490	----	----	----
	C3	1	----	----	----	2196 650	----
	CLIP	2	----	----	----	6000 050	----
	C1, C2	1	----	----	----	2196 837	----
	CLIP	2	----	----	----	6000 050	----
23-19-117	BASE, Deck Lid Name Plate	Le 1 Baron 1	----	----	----	----	1961 322 1961 323
23-19-133	COVER, Deck Lid Lock Striker Support	1	----	----	----	----	2086 735

★ Indicates use as required.

⊠ Indicates parts not listed in any previous parts book.
Dec. 9, 1960 Supersedes April 20, 1960.

CODE	REMARKS	PER CAR	PLYMOUTH	DODGE	DESOTO	CHRYSLER	IMPERIAL	
23-19-0 DECK LID - Cont'd								
23-19-177	BAR, Deck Lid Hinge Torsion D1, D2, except Cv.Cp. D3, D4, except Cv.Cp.	Right	1 1884 614	1884 616	1884 614	1884 614	---- --	
		Left	1 1884 615	1884 617	1884 615	1884 615	---- --	
		Right	1 ---- --	1964 512	---- --	---- --	1877 540	
		Left	1 ---- --	1964 513	---- --	---- --	1877 541	
23-19-178	ROLLER or SUPPORT, Deck Lid Hinge Torsion Bar End except Cv. Cp. Cv. Cp.	All	2 1952 228	1952 228	1952 228	1952 228	6006 243	
			2 ---- --	---- --	---- --	---- --	6006 243	
		RETAINER, Center	2 ---- --	---- --	---- --	---- --	6000 594	
23-19-185	LINK, Deck Lid Hinge to Torsion Bar except Cv. Cp. Cv. Cp.		2 ---- --	---- --	---- --	---- --	1877 521	
			2 ---- --	---- --	---- --	---- --	1877 520	
23-20-0 FLOOR MATS								
23-20-8	MAT, Front Floor Taxi except P1-H, P2-H P1-M, P2-M, except Sub. Sub., C1 4 D. Sub.	Black	1 2192 413	---- --	---- --	---- --	---- --	
		Black	1 2163 520	---- --	---- --	---- --	---- --	
		Green	1 2163 519	---- --	---- --	---- --	---- --	
		Turquoise	1 2163 522	---- --	---- --	---- --	---- --	
		Blue	1 2163 518	---- --	---- --	---- --	---- --	
		Black	1 2163 520	---- --	---- --	2163 520	---- --	
		Blue	1 2163 518	---- --	---- --	---- --	---- --	
		Green	1 2163 519	---- --	---- --	---- --	---- --	
		Turquoise	1 2163 522	---- --	---- --	---- --	---- --	
		All	Blue	1 ---- --	2163 518	---- --	---- --	---- --
			Green	1 ---- --	2163 519	---- --	---- --	---- --
	Black	1 ---- --	2163 520	---- --	---- --	---- --		
	Brown	1 ---- --	2091 545	---- --	---- --	---- --		
23-20-11	MAT, Intermediate Floor 4 D. Sub., 2 D. Sub.	Blue	1 *2163 606	*2163 606	---- --	---- --	---- --	
		Green	1 2163 607	2163 607	---- --	---- --	---- --	
		Turquoise	1 *2163 609	---- --	---- --	---- --	---- --	
		Black	1 2163 608	2163 608	---- --	---- --	---- --	
		Brown	1 ---- --	2091 764	---- --	---- --	---- --	
23-20-14	Sp. 4 D. Sub., C1 PLATE, Door Sill Scuff 4 D.	Black	1 ---- --	---- --	---- --	2163 608	---- --	
		Front, Right	1 1882 886	1882 888	1882 890	1882 892	1839 950	
4 D., D3, D4	4 D. Sub.	Left	1 1882 887	1882 889	1882 891	1882 893	1839 951	
		Rear, Right	1 1882 902	1882 902	1884 454	1884 454	1839 954	
		Left	1 1882 903	1882 903	1884 455	1884 455	1839 955	
		Front, Right	1 1882 886	1882 888	---- --	---- --	---- --	
		Left	1 1882 887	1882 889	---- --	---- --	---- --	
		Rear, Right	1 1884 454	1884 454	---- --	---- --	---- --	
		Left	1 1884 455	1884 455	---- --	---- --	---- --	
		Sp. 4 D.	Front, Right	1 1884 420	1884 422	1884 424	1884 426	1839 950
			Left	1 1884 421	1884 423	1884 425	1884 427	1839 951
		Sp. 4 D., D3, D4	Rear, Right	1 1884 452	1884 452	1884 456	1884 456	1839 954
Sp. 4 D. Sub.	Sp. 4 D. Sub.	Left	1 1884 453	1884 453	1884 457	1884 457	1839 955	
		Front, Right	1 ---- --	1884 422	---- --	1884 426	---- --	
		Left	1 ---- --	1884 423	---- --	1884 427	---- --	
		Rear, Right	1 ---- --	1884 456	---- --	1884 456	---- --	
Sp. 4 D. Sub., D1, D2	Sp. 4 D. Sub., D1, D2	Left	1 ---- --	1884 457	---- --	1884 457	---- --	
		Right	1 1882 894	1882 896	1882 898	1882 900	1839 952	
		Left	1 1882 895	1882 897	1882 899	1882 901	1839 953	
Sp. 4 D., D1, D2	Sp. 4 D., D1, D2	Rear, Right	1 ---- --	1884 456	---- --	---- --	---- --	
		Left	1 ---- --	1884 457	---- --	---- --	---- --	
		Rear, Right	1 ---- --	1884 454	---- --	---- --	---- --	
		Left	1 ---- --	1884 455	---- --	---- --	---- --	
23-20-16	INSERT, Door Sill Plate Tread C3-300	★	---- --	---- --	---- --	1766 986	1839 956	

★ Indicates use as required.

□ Indicates parts not listed in any previous parts book.

* Indicates change or addition.

1960 PASSENGER CAR PARTS CATALOG

BODY

CODE	REMARKS	PER CAR	PLYMOUTH	DODGE	DESOTO	CHRYSLER	IMPERIAL
23-20-0 FLOOR MATS - Cont'd							
23-20-19	SUPPORT, Door Sill Scuff Plate Cl.Sed., Sp.Cl.Cp., Cv.Cp., 2 D.Sub.	Right Left	1 1	1954 316 1954 317	1954 316 1954 317	1954 316 1954 317	1954 316 1954 317
	4 D., Sp. 4 D., 4 D.Sub., Sp. 4 D.Sub.	Front, Right Left	1 1	1954 286 1954 287	1954 286 1954 287	1954 286 1954 287	1954 286 1954 287
		Rear, Right Left	1 1	1954 288 1954 289	1954 288 1954 289	1954 288 1954 289	1954 288 1954 289
	4 D., Sp. 4 D.	Front	2	----	----	----	1692 173
		Rear, Right	1	----	----	----	1692 172
	Sp.Cl.Cp., Cv.Cp.		2	----	----	----	1690 742
23-20-20	EXTENSION, Door Sill Scuff Plate Support, Galvanized						
	2 D.Sub.	Right Left	1 1	1963 354 1963 343	----	----	----
	4 D. Sub., Sp. 4 D. Sub.	Rear, Right Left	1 1	1963 380 1963 381	1963 380 1963 381	1963 380 1963 381	----
23-20-24	EXTENSION, Door Sill Scuff Plate, Aluminum						
	Cl.Sed.	Right Left	1 1	1963 352 1963 353	1963 352 1963 353	----	----
	2 D. Sub.	Right Left	1 1	1963 310 1963 311	----	----	----
	Sp.Cl.Cp., Cv.Cp.	Right Left	1 1	1954 866 1954 867	1954 866 1954 867	1954 866 1954 867	----
	4 D., Sp. 4 D.	Rear, Right Left	1 1	1963 308 1963 309	1963 308 1963 309	1963 308 1963 309	----
	4 D.Sub., Sp. 4 D.Sub.	Rear, Right Left	1 1	1963 378 1963 379	1963 378 1963 379	1963 378 1963 379	----
	4 D.Sub., Sp. 4 D.Sub., use w/Air Condition- ing	Right Left	1 1	2094 276 2094 277	2094 276 2094 277	2094 276 2094 277	----
	C3-300	Right Left	1 1	----	----	1963 648 1963 649	----
	All	On Cowl, Right Left	1 1	1963 654 1963 655	1963 654 1963 655	1963 654 1963 655	----
23-20-29	MAT, Rear Deck Floor		1	2163 847	2192 630	2169 672	2169 672
23-20-41	MAT, Rear Floor						
	except Sub., P1-H, P2-H	Black	1	2163 526	----	----	----
	P1-L, P1-M, P2-L, P2-M, except Sub.	Turquoise	1	*2163 528	----	----	----
		Blue	1	2163 524	----	----	----
		Red	1	2163 527	----	----	----
		Green	1	2163 525	----	----	----
	Sub., P1-L, P2-L	Black	1	2163 700	----	----	----
	4 D., Sp.Cl.Cp., Cv.Cp.	Blue	1	----	*2163 524	----	----
		Green	1	----	2163 525	----	----
		Black	1	----	2163 526	----	----
		Brown	1	----	2091 552	----	----
	Cl. Sed.	Blue	1	----	2163 524	----	----
		Green	1	----	2163 525	----	----
		Black	1	----	2163 526	----	----
		Brown	1	----	2192 408	----	----
	Sub., 3rd Seat Well	Black	1	2163 919	2163 919	2163 919	----
23-20-65	PLATE, Center Pillar Scuff						
	4 D., 4 D.Sub.		2	1954 648	1954 648	1954 648	1954 648
	Sp. 4 D., Sp. 4 D.Sub.	Right Left	1 1	1954 650 1954 651	1954 650 1954 651	1954 650 1954 651	1954 650 1954 651
23-21-0 MIRRORS							
23-21-3	MIRROR PACKAGE, Rear View						
	Inside Mirror-Matic		1	2161 079	2161 079	2161 079	2161 079
	Consists of:						
	1 - ---- - Mirror						
	1 - ---- - Cable						
	1 - ---- - Terminal						
	1 - ---- - Instruction Sheet						

★ Indicates use as required.

⊠ Indicates parts not listed in any previous parts book.
Dec. 9, 1960 Supersedes April 20, 1960.

Printed in U.S.A.
Prices and specifications subject to change without notice.

* Indicates change or addition.

CODE	REMARKS	PER CAR	PLYMOUTH	DODGE	DESOTO	CHRYSLER	IMPERIAL
23-21-0 MIRRORS - Cont'd							
23-21-3	MIRROR PACKAGE - Cont'd Outside Remote Control	★	2084 787	2084 787	2084 787	2084 787	---- --
	Consists of:						
	1 - ---- --- Mirror						
	1 - 2080 541 Nut						
	1 - ---- --- Bracket						
	2 - ---- --- Screw						
	2 - 274 791 Screw						
	1 - ---- --- Instruction Sheet						
	Outside Hood Type, Double Strut	★	2196 255	2196 255	2196 255	2196 255	2196 255
	Also Matching Mirror for Remote Control						
	Mirror						
	Consists of:						
	1 - ---- --- Mirror						
	2 - 274 791 Screw						
	1 - ---- --- Anti-Squeak						
	1 - ---- --- Instruction Sheet						
23-21-8	MIRROR, Rear View Inside						
	Chrome	1	1876 331	1876 331	1876 331	1876 331	1876 331
	Prismatic Stainless Steel	1	1902 138	1902 138	1902 138	1902 138	1902 138
	Chrome	1	---- ---	---- ---	1902 053	---- ---	---- ---
23-21-14	BASE, Rear View Inside Mirror						
	Chrome	1	2086 275	2086 275	2086 275	2086 275	---- ---
	NUT	1	145 509	145 509	145 509	145 509	---- ---
	w/PAD, Chrome	1	---- ---	---- ---	2080 411	2080 411	---- ---
	Except Cv. Cp.	1	---- ---	---- ---	---- ---	---- ---	2080 774
	Cv. Cp.	1	---- ---	---- ---	---- ---	---- ---	2080 897
	All Mirror-Matic	1	---- ---	---- ---	---- ---	---- ---	2161 609
23-21-15	MIRROR, Rear View Outside						
	Double Strut	★	1773 071	1773 071	1773 071	1773 071	---- ---
	SCREW	2	274 791	274 791	274 791	274 791	---- ---
	Hood Type Single Strut	1	1839 852	1839 852	1839 852	1839 852	1839 852
	SCREW	2	274 791	274 791	274 791	274 791	274 791
	Single Strut	★	1772 447	1772 447	1772 447	1772 447	1772 447
	BRACKET	1	*1609 540	*1609 540	*1609 540	*1609 540	*1609 540
	SCREW	1	*125 978	*125 978	*125 978	*125 978	*125 978
	Remote Control	1	---- ---	---- ---	---- ---	---- ---	2080 921
23-21-18	ANTI-SQUEAK or SEAL, Rear View Outside Mirror Base						
	Round	★	1609 381	1609 381	1609 381	1609 381	1609 381
	Oblong	★	1839 670	1839 670	1839 670	1839 670	1839 670
23-21-26	RETAINER, Rear View Inside Mirror Shaft	1	1839 965	1839 965	1839 965	1839 965	---- ---
	Except Cv. Cp.	1	---- ---	---- ---	---- ---	---- ---	2080 776
23-21-27	RING, Rear View Inside Mirror Shaft Wire Retaining (Mirror-Matic)						
	Upper	1	---- ---	---- ---	---- ---	---- ---	2161 293
	Lower	1	---- ---	---- ---	---- ---	---- ---	2161 294
23-21-32	HANDLE, Rear View Outside Mirror Remote Control	1	2080 721	2080 721	2080 721	2080 721	2080 861
23-21-33	CLIP, Rear View Inside Mirror Wiring (Mirror-Matic)	1	---- ---	---- ---	---- ---	---- ---	1798 154
23-21-45	SHAFT, Rear View Inside Mirror	1	2080 875	2080 874	2080 874	2080 874	---- ---
	Chrome w/PAD	1	---- ---	---- ---	---- ---	2161 467	---- ---
	Except Cv. Cp. Mirror-Matic	1	---- ---	---- ---	---- ---	---- ---	*2161 329
23-21-46	SPRING, Rear View Inside Mirror Shaft Tension	1	1839 966	1839 966	1839 966	1839 966	---- ---
23-21-47	PLUG, Rear View Inside Mirror Shaft Tension Adjusting	1	1839 967	1839 967	1839 967	1839 967	---- ---
23-21-65	HOUSING, Rear View Outside Mirror Remote Control	1	---- ---	---- ---	---- ---	2080 471	---- ---
	STUD	2	---- ---	---- ---	---- ---	6010 020	---- ---
23-21-66	BEZEL, Rear View Outside Mirror Remote Control Housing	1	2080 698	2080 539	2080 539	2080 489	2080 699
23-21-67	PLATE, Rear View Outside Mirror Remote Control Mounting	1	---- ---	2080 540	2080 540	---- ---	---- ---
23-21-74	NUT, Rear View Outside Mirror Remote Control Attaching	1	2080 839	2080 541	2080 541	1901 838	2080 839

★ Indicates use as required.

☐ Indicates parts not listed in any previous parts book.

* Indicates change or addition.

Printed in U.S.A.

Prices and specifications subject to change without notice.

Dec. 9, 1960 Supersedes April 20, 1960.

1960 PASSENGER CAR PARTS CATALOG

BODY

CODE	REMARKS	PER CAR	PLYMOUTH	DODGE	DESOTO	CHRYSLER	IMPERIAL
23-22-0 GARNISH MOULDINGS							
23-22-7	MOULDING, Door Garnish Cl. Sed., 2 D. Sub.						
	Prime, Right	1	1883 092	1883 092	----	----	----
	Left	1	1883 093	1883 093	----	----	----
	4 D., C1, C2						
	Prime, Front, Right	1	1883 148	1883 148	1883 148	1883 148	----
	Left	1	1883 149	1883 149	1883 149	1883 149	----
	4 D., D1, D2, C1, C2						
	Prime, Rear, Right	1	1883 160	1883 168	1883 168	1883 168	----
	Left	1	1883 161	1883 169	1883 169	1883 169	----
	4 D. Sub.						
	Prime, Front, Right	1	1883 148	1883 148	----	----	----
	Left	1	1883 149	1883 149	----	----	----
	Rear, Right	1	1883 168	1883 168	----	----	----
	Left	1	1883 169	1883 169	----	----	----
	Sp. 4 D., Sp. 4 D. Sub.						
	Prime, Front, Right	1	1883 116	1883 116	1883 116	1883 116	----
	Left	1	1883 117	1883 117	1883 117	1883 117	----
	Sp. 4 D., Sp. 4 D. Sub., D1, D2						
	Rear, Right	1	1883 128	1883 132	1883 132	1883 132	----
	Left	1	1883 129	1883 133	1883 133	1883 133	----
	4 D., D3, D4						
	Prime, Rear, Right	1	----	1883 160	----	----	----
	Left	1	----	1883 161	----	----	----
	Sp. 4 D., D3, D4						
	Prime, Rear, Right	1	----	1883 128	----	----	----
	Left	1	----	1883 129	----	----	----
	Sp. Cl. Cp., Cv. Cp., S1, C1						
	Prime, Right	1	1883 084	1883 084	1883 084	1883 084	----
	Left	1	1883 085	1883 085	1883 085	1883 085	----
	Sp. 4 D., D3, D4						
	Chrome, Rear, Right	1	----	1964 534	----	----	----
	Left	1	----	1964 535	----	----	----
	Sp. 4 D., Sp. 4 D. Sub.,						
	Chrome, Front, Right	1	----	*1963 952	*1963 952	----	----
	Left	1	----	1963 953	1963 953	----	----
	Sp. 4 D., Sp. 4 D. Sub., D1, D2, Chrome,						
	Rear, Right	1	----	*1964 004	*1964 004	----	----
	Left	1	----	1964 005	1964 005	----	----
	Sp. Cl. Cp., Cv. Cp.						
	Chrome, Right	1	1963 918	1963 918	1963 918	----	----
	Left	1	1963 919	1963 919	1963 919	----	----
	4 D., C2, C3						
	Prime, Front, Right	1	----	----	----	1883 156	----
	Left	1	----	----	----	1883 157	----
	Rear, Right	1	----	----	----	1883 176	----
	Left	1	----	----	----	1883 177	----
	4 D., C3						
	Chrome, Front, Right	1	----	----	----	1963 690	----
	Left	1	----	----	----	1963 691	----
	Rear, Right	1	----	----	----	1963 692	----
	Left	1	----	----	----	1963 693	----
23-22-8	SCREW, Windshield Garnish Moulding						
	Cv. Cp. Side	6	892 569	892 569	----	892 569	----
23-22-9	SUPPORT, Rear Door Garnish Moulding Front						
	Sp. 4 D.	2	☐2166 418	☐2166 418	☐2166 418	☐2166 418	----
23-22-13	CLIP, Rear Window Lower Garnish Moulding						
	4 D., Sp. 4 D., YH	9	----	----	----	----	6008 223
23-22-15	SUPPORT, Windshield Upper Garnish Moulding and Visor Hook						
	Cv. Cp.	1	*1964 348	*1964 348	----	*1964 348	----
23-22-53	MOULDING, Front Quarter Window Garnish						
	2 D. Sub.						
	Right	1	1883 100	----	----	----	----
	Left	1	1883 101	----	----	----	----
	MOULDING, Rear Quarter Window Garnish						
	4 D. Sub., 2 D. Sub. Front to Roof Rail, Right	1	1902 304	1902 304	----	----	----
	Left	1	1902 305	1902 305	----	----	----
	Sp. 4 D. Sub.						
	Front to Roof Rail, Right	1	----	1902 306	----	1902 306	----
	Left	1	----	1902 307	----	1902 307	----
	Sub.						
	Front, Right	1	1839 926	1839 926	----	1839 926	----
	Left	1	1839 927	1839 927	----	1839 927	----
	Upper Center, Right	1	1839 928	1839 928	----	1839 928	----
	Left	1	1839 929	1839 929	----	1839 929	----
	Upper Rear, Right	1	1839 932	1839 932	----	1839 932	----
	Left	1	1839 933	1839 933	----	1839 933	----
	Lower Center, Right	1	1839 930	1839 930	----	1839 930	----
	Left	1	1839 931	1839 931	----	1839 931	----
	Lower Rear, Right	1	1839 934	1839 934	----	1839 934	----
	Left	1	1839 935	1839 935	----	1839 935	----

★ Indicates use as required. Numerals in parentheses () refer to notes. Printed in U.S.A.
 ☐ Indicates parts not listed in any previous parts book. Prices and specifications subject to change without notice.
 April 20, 1960 Supersedes Dec. 30, 1959. Page 23-56 * Indicates change or addition.

CODE	REMARKS	PER CAR	PLYMOUTH	DODGE	DESOTO	CHRYSLER	IMPERIAL
23-22-0 GARNISH MOULDINGS - Cont'd							
23-22-53	MOULDING, Quarter Window Garnish						
	Cl.Sed.						
	Prime, Right	1	1963 722	1963 722	----	----	----
	Left	1	1963 723	1963 723	----	----	----
	Cv. Cp.						
	Chrome, Right	1	1963 914	1964 914	----	----	----
	Left	1	1963 915	1963 915	----	----	----
	Sp. Cl. Cp., C3						
	Chrome, Right	1	*1963 910	1963 910	2161 402	2161 402	----
	Left	1	*1963 911	1963 911	2161 403	2161 403	----
	End, Right	1	----	----	2086 054	2080 314	----
	Left	1	----	----	2086 055	2080 315	----
	Sp. Cl. Cp., C1, C2						
	Prime, Right	1	1883 006	1883 006	1839 942	1839 942	----
	Left	1	1883 007	1883 007	1839 943	1839 943	----
	End, Right	1	----	----	1901 866	1901 866	----
	Left	1	----	----	1901 867	1901 867	----
	Cv. Cp., C1						
	Prime, Right	1	1883 014	1883 014	----	1883 022	----
	Left	1	1883 015	1883 015	----	1883 023	----
	Sp. 4 D., S1, C1, C2, w/Low Window,						
	Prime, Belt, Right	1	1884 828	1884 828	1884 828	1884 828	----
	Left	1	1884 829	1884 829	1884 829	1884 829	----
	Sp. 4 D., D3, D4, w/High Window,						
	Prime, Belt, Right	1	1952 972	1952 972	1952 976	1952 976	----
	Left	1	1952 973	1952 973	1952 977	1952 977	----
	Sp. 4 D., D3-H, D4-H, C3, w/High Window,						
	Chrome, Belt, Right	1	1964 540	1964 540	1963 710	1963 710	----
	Left	1	1964 541	1964 541	1963 711	1963 711	----
	Sp. 4 D., D1, D2, w/High Window,						
	Prime, Belt, Right	1	----	1952 976	----	----	----
	Left	1	----	1952 977	----	----	----
	Sp. 4 D., D2-H, w/High Window, Chrome, Belt,						
	Right	1	----	1963 710	----	----	----
	Left	1	----	1963 711	----	----	----
	Sp. 4 D., S1, w/Low Window						
	Chrome, Belt, Right	1	----	----	1963 708	----	----
	Left	1	----	----	1963 709	----	----
	4 D.						
	Chrome, Belt, Right	1	----	----	----	----	1902 002
	Left	1	----	----	----	----	1902 003
	Rear, Right	1	----	----	----	----	2080 858
	Left	1	----	----	----	----	2080 859
	Sp. 4 D.						
	Chrome, Belt, Right	1	----	----	----	----	1901 994
	Left	1	----	----	----	----	1901 995
	Rear, Right	1	----	----	----	----	2080 858
	Left	1	----	----	----	----	2080 859
23-22-55	SUPPORT, Quarter Window Garnish Moulding						
	Cl.Sed.						
	Right	1	1909 488	1909 488	----	----	----
	Left	1	1909 489	1909 489	----	----	----
	2 D.Sub.						
	Right	1	1909 490	----	----	----	----
	Left	1	1909 491	----	----	----	----
23-22-77	MOULDING, Tailgate Belt Garnish						
	Sub.						
	Prime	1	1839 977	1839 977	1839 977	1839 977	----
23-22-78	MOULDING, Tailgate Opening Garnish						
	Sub.						
	Upper	1	1839 976	1839 976	----	1839 976	----
23-22-80	SPACER, Tailgate Belt Garnish Moulding						
	Sub.						
	Outer	2	2094 449	2094 449	----	2094 449	----
23-22-81	SEAL, Tailgate Garnish Moulding End						
23-22-85	COVER, Rear Window Garnish Moulding						
	Joint						
	Sp. Cl. Cp., High Window						
	Prime, Upper, Right	1	----	1954 848	----	----	----
	Left	1	----	1954 849	----	----	----
	Sp. Cl. Cp., Low Window						
	Prime, Upper, Right	1	----	1963 630	----	----	----
	Left	1	----	1963 631	----	----	----
	Sp. Cl. Cp., D4, High Window,						
	Chrome, Upper, Right	1	----	1964 492	----	----	----
	Left	1	----	1964 493	----	----	----
	Sp. 4 D.						
	High Window, Chrome, Upper	1	----	1963 670	1963 670	1963 670	----
	Sp. Cl. Cp.				*2086 168	*2086 168	----
	High Window, Chrome, Center	1	----	----	----	----	----
	All						
	Low Window, Chrome, Upper	1	----	----	----	----	1901 990
	Lower	1	----	----	----	----	1901 991

★ Indicates use as required.

⊠ Indicates parts not listed in any previous parts book.

* Indicates change or addition.

1960 PASSENGER CAR PARTS CATALOG

BODY

CODE	REMARKS	PER CAR	PLYMOUTH	DODGE	DESOTO	CHRYSLER	IMPERIAL
23-22-0 GARNISH MOULDINGS - Cont'd							
23-22-86	MOULDING, Rear Low Window Garnish						
	4 D., Sp. 4 D., Cl. Sed., D1, D2, S1						
	Prime, Upper	1	----	1882 955	1882 955	1882 955	----
	Sp. 4 D., D1, D2, S1, C1, C2						
	Prime, Side, Right	1	----	1883 002	1883 002	1883 002	----
	Left	1	----	1883 003	1883 003	1883 003	----
	4 D., Cl. Sed., S1						
	Prime, Side, Right	1	----	2165 460	1883 002	1883 002	----
	Left	1	----	2165 461	1883 003	1883 003	----
	4 D., S1, C3						
	Chrome, Upper	1	----	----	*1964 154	*1964 154	----
	Side, Right	1	----	----	*1964 152	1964 152	----
	Left	1	----	----	*1964 153	1964 153	----
	Sp. Cl. Cp.						
	Prime, Side, Right	1	----	1882 998	----	----	----
	Left	1	----	1882 999	----	----	----
	MOULDING, Rear High Window Garnish						
	Sp. 4 D., D1, D2, S3						
	Prime, Upper and Side, Right	1	----	1952 654	----	1952 654	----
	Left	1	----	1952 655	----	1952 655	----
	4 D., Sp. 4 D.						
	Prime, Upper and Side, Right	1	----	----	*1952 654	----	----
	Left	1	----	----	1952 655	----	----
	4 D., Sp. 4 D.,						
	Chrome, Upper and Side, Right	1	----	*1963 668	*1963 668	----	----
	Left	1	----	*1963 669	1963 669	----	----
	Sp. 4 D., C3						
	Chrome, Upper and Side, Right	1	----	----	----	*1963 668	----
	Left	1	----	----	----	1963 669	----
	Sp. Cl. Cp.						
	Prime, Upper	1	----	1952 693	----	----	----
	Side, Right	1	----	1952 696	----	----	----
	Left	1	----	1952 697	----	----	----
	Sp. Cl. Cp., D2-H						
	Chrome, Upper	1	----	1964 416	----	----	----
	Side, Right	1	----	1964 414	----	----	----
	Left	1	----	1964 415	----	----	----
	Sp. Cl. Cp., C3						
	Chrome, Upper, Right	1	----	----	2086 056	2086 056	----
	Left	1	----	----	2086 057	2086 057	----
	Sp. Cl. Cp.						
	Prime, Upper, Right	1	----	----	1839 940	1839 940	----
	Left	1	----	----	1839 941	1839 941	----
	MOULDING, Rear Window Garnish						
	4 D., Sp. 4 D.						
	Chrome, Upper, Right	1	----	----	----	----	1901 971
	Left	1	----	----	----	----	1901 972
	Lower, Right	1	----	----	----	----	1901 969
	Left	1	----	----	----	----	1901 970
	Lower Corner, Right	1	----	----	----	----	1901 992
	Left	1	----	----	----	----	1901 993
	Sp. Cl. Cp.						
	Chrome, Upper, Right	1	----	----	----	----	⊠1901 988
	Left	1	----	----	----	----	⊠1901 989
	Lower, Right	1	----	----	----	----	1901 986
	Left	1	----	----	----	----	1901 987
	Lower Corner, Right	1	----	----	----	----	1902 000
	Left	1	----	----	----	----	1902 001
23-22-145	MOULDING, Windshield Garnish						
	Except Cv. Cp.						
	Prime, Upper	1	1882 913	1882 913	1882 913	1882 913	----
	Side, Right	1	1882 918	1882 918	1882 918	1882 918	----
	Left	1	1882 919	1882 919	1882 919	1882 919	----
	Lower, Right	1	*1839 546	*1839 546	*1839 546	*1839 558	----
	Left	1	*1839 547	*1839 547	*1839 547	*1839 559	----
	Cv. Cp.						
	Chrome, Upper	1	1954 048	1954 048	----	1954 048	2093 619
	Side, Right	1	1963 346	1963 346	----	1963 346	1901 998
	Left	1	1963 347	1963 347	----	1963 347	1901 999
	Cv. Cp.						
	Prime, Upper	1	1882 915	1882 915	----	1882 915	----
	Lower, Right	1	*1839 546	*1839 546	----	1839 558	----
	Left	1	*1839 547	*1839 547	----	1839 559	----
	Sp. 4 D., Sp. Cl. Cp., P1-H, P2-H						
	Chrome, Upper	1	1963 957	----	----	----	----
	Side, Right	1	1963 958	----	----	----	----
	Left	1	1963 959	----	----	----	----

★ Indicates use as required.

⊠ Indicates parts not listed in any previous parts book.
Dec. 9, 1960 Supersedes April 20, 1960.

Printed in U.S.A.

Prices and specifications subject to change without notice.

* Indicates change or addition.

CODE	REMARKS	PER CAR	PLYMOUTH	DODGE	DESOTO	CHRYSLER	IMPERIAL
23-22-0 GARNISH MOULDINGS - Cont'd							
23-22-145	MOULDING - Cont'd C3, except Cv. Cp.						
	Chrome, Upper	1	----	----	1963 957	1963 957	----
	Side, Right	1	----	----	1963 958	1963 958	----
	Left	1	----	----	1963 959	1963 959	----
	Except Cv. Cp. Chrome, Upper, Right	1	----	----	----	----	2080 782
	Left	1	----	----	----	----	2080 783
	Side, Right	1	----	----	----	----	1901 996
	Left	1	----	----	----	----	1901 997
All	Plate, Inner, Right	1	----	----	----	----	2080 306
	Left	1	----	----	----	----	2080 307
	Outer, Right	1	----	----	----	----	1902 274
	Left	1	----	----	----	----	1902 275
All	Prime, Lower, Right	1	----	----	----	----	1839 566
	Left	1	----	----	----	----	1839 567
	Sp. 4 D., Sp. Cl. Cp., Chrome, Upper Corner, Right	1	----	----	----	----	1901 974
	Left	1	----	----	----	----	1901 975
23-22-148	COVER, Windshield Garnish Moulding Center Joint						
	Prime, Upper	1	----	----	----	----	2080 125
	Chrome, Lower	1	----	----	----	----	2080 284
23-22-151	SUPPORT, Windshield Garnish Moulding						
	Side Upper	2	1963 956	1963 956	1963 956	1963 956	----
	Upper	1	1964 348	1964 348	1964 348	1964 348	----
23-22-152	SPACER, Windshield Upper Garnish Moulding except Cv. Cp.	6	----	----	----	----	*1901 973
23-22-160	ORNAMENT, Windshield Lower Garnish Moulding	6	----	----	----	----	2080 285
	NUT	★	----	----	----	----	6008 032
23-23-0 OUTSIDE FINISH MOULDINGS							
23-23-2	MOULDING PACKAGE, Body Side Sill Outside Finish						
	P1-H, P2-H, except 4 D. Sub. Right	1	*2084 737	----	----	----	----
	CLIP	6	*6000 732	----	----	----	----
	SCREW	1	* 161 895	----	----	----	----
	Left	1	E2196 874	----	----	----	----
	CLIP	6	*6000 732	----	----	----	----
	SCREW	1	* 161 895	----	----	----	----
	4 D. Sub., P1-H, P2-H Right	1	2196 186	----	----	----	----
	CLIP	5	6000 732	----	----	----	----
	Left	1	2196 187	----	----	----	----
	CLIP	5	6000 732	----	----	----	----
All	Right	1	----	----	2196 524	----	----
	CLIP	4	----	----	6000 732	----	----
	Left	1	----	----	2196 525	----	----
	CLIP	4	----	----	6000 732	----	----
C1	Right	1	----	----	----	2196 730	----
	CLIP	7	----	----	----	6000 732	----
	CLIP and BOLT	1	----	----	----	6010 046	----
	NUT	1	----	----	----	151 497	----
	Left	1	----	----	----	2196 731	----
	CLIP	7	----	----	----	6000 732	----
	CLIP and BOLT	1	----	----	----	6010 046	----
	NUT	1	----	----	----	151 497	----
C2	Right	1	----	----	----	2196 732	----
	CLIP	7	----	----	----	6000 732	----
	CLIP and BOLT	1	----	----	----	6010 046	----
	NUT	1	----	----	----	151 497	----
	Left	1	----	----	----	2196 733	----
	CLIP	7	----	----	----	6000 732	----
	CLIP and BOLT	1	----	----	----	6010 046	----
	NUT	1	----	----	----	151 497	----

★ Indicates use as required.

☐ Indicates parts not listed in any previous parts book.

* Indicates change or addition.

1960 PASSENGER CAR PARTS CATALOG

BODY

CODE	REMARKS	PER CAR	PLYMOUTH	DODGE	DESOTO	CHRYSLER	IMPERIAL
23-23-0 OUTSIDE FINISH MOULDING-Cont'd							
23-23-2	MOULDING PACKAGE - Cont'd						
	C3						
	CLIP	Right	1	----	----	2196 734	----
	CLIP		6	----	----	6000 732	----
	CLIP and BOLT		1	----	----	6010 046	----
	NUT		1	----	----	151 497	----
		Left	1	----	----	2196 735	----
	CLIP		6	----	----	6000 732	----
	CLIP and BOLT		1	----	----	6010 046	----
	NUT		1	----	----	151 497	----
	All	Right	1	----	----	----	2196 680
	CLIP		8	----	----	----	6006 449
		Left	1	----	----	----	2196 681
	CLIP		8	----	----	----	6006 449
23-23-14	MOULDING, Front Pillar Face						
	Cv. Cp.	Right	1	----	----	----	2093 136
		Left	1	----	----	----	2093 137
23-23-22	SUPPORT, Rear Window Lower Moulding Clip		★	1954 662	1954 662	1954 662	----
23-23-23	MOULDING PACKAGE, Deck Opening Lower Panel	License Well	1	----	----	2196 514	2196 664
	NUT and SEAL		6	----	----	6006 264	6006 264
	C1, C2, C3-300	Right	1	----	----	----	2196 655
	CLIP		3	----	----	----	6006 443
		Left	1	----	----	----	2196 656
	CLIP		3	----	----	----	6006 443
C3		Right	1	----	----	----	2196 657
	CLIP		3	----	----	----	6006 443
		Left	1	----	----	----	2196 658
	CLIP		3	----	----	----	6006 443
		Right	1	----	----	----	2196 828
	CLIP and BOLT		5	----	----	----	6000 709
		Left	1	----	----	----	2196 829
	CLIP and BOLT		5	----	----	----	6000 709
		Filler Door	1	----	----	----	2196 549
	SCREW		2	----	----	----	159 229
23-23-24	MOULDING PACKAGE, Deck Lid License Insert Panel						
		Chrome	1	----	2196 106	----	----
	NUT and SEAL		6	----	6000 616	----	----
23-23-25	REFLECTOR, Quarter Panel		2	----	----	----	1960 060
23-23-26	SEAL, Quarter Panel Reflector		2	----	----	----	1960 499
23-23-30	MOULDING PACKAGE, Deck Lid		1	----	2196 262	----	----
	CLIP and BOLT		7	----	6000 709	----	----
	NUT		7	----	441 256	----	----
	C3	Center	1	----	----	----	2196 838
	NUT		6	----	----	----	6006 215
	All		1	----	----	----	----
	RETAINER		4	----	----	----	2196 548
	SCREW		4	----	----	----	6006 467
23-23-32	MOULDING, Front Door Outside Window Opening Frame						161 788
NOTE: See illustration in front of group for Mouldings not listed.							
4 D.	Front, Right		1	1884 976	1884 976	1954 914	1954 914
	Left		1	1884 977	1884 977	1954 915	1954 915
	Upper, Right		1	1884 978	1884 978	1884 978	1884 978
	Left		1	1884 979	1884 979	1884 979	1884 979
	Rear, Right		1	1884 980	1884 980	1884 980	1884 980
	Left		1	1884 981	1884 981	1884 981	1884 981
	MOULDING PACKAGE, Front Door Outside Finish						
4 D.	Belt, Front, Right		1	----	----	----	2196 686
	SCREW		1	----	----	----	274 831
	SCREW		1	----	----	----	----
		Left	1	----	----	----	2196 687
	SCREW		1	----	----	----	274 831

★ Indicates use as required.

□ Indicates parts not listed in any previous parts book.
Dec. 9, 1960 Supersedes April 20, 1960.

Prices and specifications subject to change without notice.

* Indicates change or addition.

Printed in U.S.A.

CODE	REMARKS	PER CAR	PLYMOUTH	DODGE	DESOTO	CHRYSLER	IMPERIAL
23-23-0 OUTSIDE FINISH MOULDING - Cont'd							
23-23-32	MOULDING PACKAGE - Cont'd						
	Rear, Right	1	----	----	----	----	2196 718
	RETAINER	4	----	----	----	----	6006 469
	Left	1	----	----	----	----	2196 719
	RETAINER	4	----	----	----	----	6006 469
23-23-33	MOULDING, Rear Door Outside Window Opening Frame						
	NOTE: See illustration in front of group for Mouldings not listed.						
4 D.	Front, Right	1	1884 982	1884 982	1884 982	1884 982	----
	Left	1	1884 983	1884 983	1884 983	1884 983	----
4 D., D3, D4	Upper, Right	1	1909 844	1909 844	1884 984	1884 984	----
	Left	1	1909 845	1909 845	1884 985	1884 985	----
4 D., D1, D2	Upper, Right	1	----	1884 984	----	----	----
	Left	1	----	1884 985	----	----	----
4 D., D3, D4	Upper Extension, Right	1	1952 466	1952 466	1954 916	1954 916	----
	Left	1	1952 467	1952 467	1954 917	1954 917	----
4 D., D1, D2	Upper Extension Right	1	----	1952 856	----	----	----
	Left	1	----	1952 857	----	----	----
	MOULDING PACKAGE, Rear Door Outside Finish						
4 D.	Belt, Front, Right	1	----	----	----	----	2196 720
	RETAINER	4	----	----	----	----	6006 469
	Left	1	----	----	----	----	2196 721
	RETAINER	4	----	----	----	----	6006 469
	Rear, Right	1	----	----	----	----	2196 722
	RETAINER	2	----	----	----	----	6006 469
	Left	1	----	----	----	----	2196 723
	RETAINER	2	----	----	----	----	6006 469
23-23-36	MOULDING, Front Door Vent Wing Division Channel						
	Inner	2	----	----	----	----	1751 325
	Outer	2	----	----	----	----	1751 323
23-23-39	MOULDING PACKAGE, Quarter Panel Outside Finish						
	NOTE: See illustration in front of group for Mouldings not listed.						
P1-H, P2-H	Wheel Opening, Right	1	*2196 180	----	----	----	----
	SCREW	7	125 978	----	----	----	----
	Left	1	2196 181	----	----	----	----
	SCREW	7	125 978	----	----	----	----
P2-H, except Sub.	Front, Right	1	*2084 738	----	----	----	----
	RETAINER and BOLT	3	6000 701	----	----	----	----
	RETAINER and BOLT	1	1954 886	----	----	----	----
	NUT and SEAL	4	----	----	----	----	----
	Left	1	2084 739	----	----	----	----
	RETAINER and BOLT	3	6000 701	----	----	----	----
	RETAINER and BOLT	1	1954 887	----	----	----	----
	NUT and SEAL	4	----	----	----	----	----
	Rear, Right	1	2084 740	----	----	----	----
	RETAINER and BOLT	4	6000 700	----	----	----	----
	RETAINER and BOLT	1	6000 702	----	----	----	----
	NUT and SEAL	5	6000 028	----	----	----	----
	Rear, Left	1	2084 741	----	----	----	----
	RETAINER and BOLT	4	6000 700	----	----	----	----
	RETAINER and BOLT	1	6000 702	----	----	----	----
	NUT and SEAL	5	6000 028	----	----	----	----
4 D., Sp. 4 D., Cl.Sed., D3, D4, w/Low Window	Belt, Right	1	2084 772	2084 772	----	----	----
	CLIP and SEAL	1	6000 862	6000 862	----	----	----
	Left	1	2084 773	2084 773	----	----	----
	CLIP and SEAL	1	6000 862	6000 862	----	----	----

★ Indicates use as required.
 □ Indicates parts not listed in any previous parts book.
 * Indicates change or addition.

CODE	REMARKS	PER CAR	PLYMOUTH	DODGE	DESOTO	CHRYSLER	IMPERIAL
23-23-0 OUTSIDE FINISH MOULDING - Cont'd							
23-23-39	MOULDING PACKAGE - Cont'd						
	All Wheel Opening, Right	1	----	----	2196 526	2196 526	----
	SCREW	7	----	----	125 978	125 978	----
	Left	1	----	----	2196 527	2196 527	----
	SCREW	7	----	----	125 978	125 978	----
	Sub. Belt, Right	1	2196 814	2196 814	----	2196 814	----
	CLIP and SEAL	1	6000 721	6000 721	----	6000 721	----
	Left	1	2196 815	2196 815	----	2196 815	----
	CLIP and SEAL	1	6000 721	6000 721	----	6000 721	----
	Y1-L Wheel Opening, Right	1	----	----	----	----	2196 820
	SCREW	5	----	----	----	----	9414 080
	Left	1	----	----	----	----	2196 821
	SCREW	5	----	----	----	----	9414 080
	All Lower Rear, Right	1	----	----	----	----	2196 830
	CLIP and BOLT	3	----	----	----	----	6000 709
	SCREW	1	----	----	----	----	9414 080
	Left	1	----	----	----	----	2196 831
	CLIP and BOLT	3	----	----	----	----	6000 709
	SCREW	1	----	----	----	----	9414 080
23-23-41	CAP or COVER, Body Outside Finish						
	Moulding Joint						
	4 D., Cl. Sed., D3, D4, Rear Window Side and Lower	2	1954 784	1954 784	----	----	----
	Sp. 4 D., P1-H, P2-H, D3-H, D4-H, w/High Window, Side and Lower Rear Window, Right	1	⊕2166 340	⊕2166 340	----	----	----
	Left	1	⊕2166 341	⊕2166 341	----	----	----
	Cv. Cp., Folding Top Belt Bar Finish Moulding	1	1963 336	1963 336	----	1963 336	----
	Sp. Cl. Cp., P1-M, P2-M, D3-M, D4-M, Rear Window Side and Upper	Right	1 1954 732	1909 604	----	----	----
	Left	1	1954 733	1909 605	----	----	----
	Sp. Cl. Cp., w/High Window Side and Upper	Right	1 1954 730	----	----	----	----
	Left	1	1954 731	----	----	----	----
	Sp. Cl. Cp., w/High Window, Side and Upper	Right	1 ----	1954 734	----	----	----
	Left	1	----	1954 735	----	----	----
	Sp. Cl. Cp., Rear Window Side and Lower	Right	1 1909 616	----	----	----	----
	Left	1	1909 617	----	----	----	----
	Sub., Quarter Window, Lower Front	2	1961 210	1961 210	----	1961 210	----
	Sp. Cl. Cp., D1, D2, Rear Window Side and Lower, PKG.	Right	1 ----	2196 290	----	----	----
	Left	1	----	2196 291	----	----	----
	SCREW	2	----	431 601	----	----	----
	Sp. Cl. Cp., D3, D4, Rear Window Side and Lower	Right	1 ----	1964 158	----	----	----
	Left	1	----	1964 159	----	----	----
	4 D., Cl. Sed., Sp. 4 D., Sp. Cl. Cp., Rear Window Upper and Lower 1 1/2" x 1 1/4" Length	2	1954 850	1954 850	1954 850	1954 850	----
	4 D., Sp. 4 D., Cl. Sed., Sp. Cl. Cp., Rear Window Upper and Lower, Center PKG. 1 5/8" x 1 19/64" lgh.	1	2093 479	2093 479	2093 479	2093 479	----
	Cv. Cp., Belt Moulding to Quarter Panel, PKG.	Right	1 ----	----	----	----	2196 682
	Left	1	----	----	----	----	2196 683
	NUT	2	----	----	----	----	120 622
	Sp. Cl. Cp., Sp. 4 D., Rear Window, Lower	1	----	----	----	----	2188 375
23-23-42	MOULDING, Roof Panel Outside Finish						
	Sp. Cl. Cp., P1-H, P2-H, Extension, PKG.	Right	1 2196 102	----	----	----	----
	Left	1	2196 103	----	----	----	----
	SCREW	2	161 589	----	----	----	----
	Sp. 4 D., P1-H, P2-H, D3-H, D4-H, Side, PKG.	Right	1 *2196 104	*2196 104	----	----	----
	Left	1	*2196 105	*2196 105	----	----	----

★ Indicates use as required.

⊕ Indicates parts not listed in any previous parts book.

Dec. 9, 1960 Supersedes April 20, 1960.

Printed in U.S.A. Prices and specifications subject to change without notice.

* Indicates change or addition.

CODE	REMARKS	PER CAR	PLYMOUTH	DODGE	DESOTO	CHRYSLER	IMPERIAL
23-23-0 OUTSIDE FINISH MOULDING - Cont'd							
23-23-42	MOULDING - Cont'd						
	SCREW	12	161 589	* 161 589	----	----	----
	Sp. Cl. Cp., P2-H, Side, PKG.	Right 1	*2196 100	----	----	----	----
		Left 1	*2196 101	----	----	----	----
	SCREW	14	161 589	161 589	----	----	----
	Sp. Cl. Cp., D1-L, D3-M, D4-M, w/Low Window, Side, Cantilever Sweep, PKG.	Right 1	----	2196 266	----	----	----
		Left 1	----	2196 267	----	----	----
	CLIP	20	----	6000 706	----	----	----
	Sp. Cl. Cp., w/High Window, Side, Cantilever Sweep, PKG.	Right 1	----	2196 264	----	----	----
		Left 1	----	2196 265	----	----	----
	CLIP	20	----	6000 706	----	----	----
	Sp. Cl. Cp., C3, Side, Front, PKG.	Right 1	----	----	2196 665	2196 665	----
		Left 1	----	----	2196 666	2196 666	----
	CLIP and SEAL	8	----	----	6006 444	6006 444	----
	Rear, PKG.	Right 1	----	----	2196 667	2196 667	----
		Left 1	----	----	2196 668	2196 668	----
	CLIP	2	----	----	5006 490	6006 490	----
	CLIP	4	----	----	6006 491	6006 491	----
	SCREW	2	----	----	162 826	162 826	----
	Sub., Rear Front, PKG.	2	2196 252	2196 252	----	2196 252	----
	CLIP	20	6006 301	6006 301	----	6006 301	----
	Sub., Top, PKG.	2	2196 253	2196 253	----	2196 253	----
	CLIP	28	6006 301	6006 301	----	6006 301	----
	4 D., Side, PKG.	Right 1	----	----	----	----	2196 800
		Left 1	----	----	----	----	2196 801
	4 D., Sp. 4 D., Upper, PKG.	Right 1	----	----	----	----	2196 692
		Left 1	----	----	----	----	2196 693
	4 D., Sp. 4 D., Top, Insert or Cover	Right 1	----	----	----	----	1961 300
		Left 1	----	----	----	----	1961 301
	Sp. 4 D., Side, PKG.	Right 1	----	----	----	----	2196 696
		Left 1	----	----	----	----	2196 697
	Sp. Cl. Cp., Upper, PKG.	Right 1	----	----	----	----	2196 694
		Left 1	----	----	----	----	2196 695
	Sp. Cl. Cp., Side, PKG.	Right 1	----	----	----	----	2196 698
		Left 1	----	----	----	----	2196 699
23-23-49	MOULDING, Folding Top Belt Outside Finish						
	Cv. Cp.	Right 1	1963 330	1963 332	----	1963 334	----
		Left 1	1963 331	1963 333	----	1963 335	----
	SCREW	20	161 798	161 798	----	161 798	----
	STUD/FASTENER	23	6000 433	6000 433	----	6000 433	----
	SCREW	40	----	----	----	----	125 978
	STUD/FASTENER	19	----	----	----	----	6000 433
	Cv. Cp., Rear, PKG.	Right 1	----	----	----	----	2196 684
		Left 1	----	----	----	----	2196 685
	FASTENER	18	----	----	----	----	6000 433
23-23-52	MOULDING, Rear Window Outside Finish						
	Sp. 4 D., P1-H, P2-H, D3, D4, Lower End, w/High Window, PKG.	Right 1	2084 776	2084 776	----	----	----
		Left 1	⊠2275 336	⊠2275 336	----	----	----
	CLIP	2	6000 721	6000 721	----	----	----
	SCREW	2	161 589	161 589	----	----	----
	Sp. 4D., P1-H, P2-H, D3, D4, w/High Window, Upper and Side, PKG.	Right 1	2084 778	2084 778	----	----	----
		Left 1	2084 779	2084 779	----	----	----
	CLIP	10	6000 692	6000 692	----	----	----
	Sp. Cl. Cp., D1, D3-M, D4-M, w/Low Window, PKG.	Upper 1	----	2196 281	----	----	----
	CLIP	10	----	6000 692	----	----	----
	Sp. Cl. Cp., D1, D3-M, D4-M, w/Low Window, PKG.	Side Right 1	----	2196 276	----	----	----
		Left 1	----	2196 277	----	----	----
	CLIP	6	----	6000 722	----	----	----
	CLIP	6	----	6000 692	----	----	----

★ Indicates use as required.

⊠ Indicates parts not listed in any previous parts book.

* Indicates change or addition.

1960 PASSENGER CAR PARTS CATALOG

BODY

CODE	REMARKS	PER CAR	PLYMOUTH	DODGE	DESOTO	CHRYSLER	IMPERIAL
23-23-0 OUTSIDE FINISH MOULDING-Cont'd							
23-23-52	MOULDING - Cont'd						
	Sp. Cl. Cp., High Window, PKG. Upper	1	----	2196 280	----	----	----
	CLIP	10	----	6000 692	----	----	----
	Sp. Cl. Cp., D1, D2, D3-M, D4-M, D3-H, D4-H, w/High Window, PKG. Side, Right	1	----	2196 278	----	----	----
	Left	1	----	2196 279	----	----	----
	CLIP	8	----	6000 722	----	----	----
	CLIP	8	----	6000 692	----	----	----
	Sp. Cl. Cp., P1-M, P2-M, w/Low Window Side, PKG. Right	1	2084 782	----	----	----	----
	Left	1	2084 783	----	----	----	----
	CLIP	10	6000 692	----	----	----	----
	4 D., Sp. 4 D., Cl. Sed., D3, D4, w/Low Window, Side and Upper, PKG. Right	1	2084 770	2084 770	----	----	----
	Left	1	2084 771	2084 771	----	----	----
	CLIP	10	6000 692	6000 692	----	----	----
	4 D., Sp. 4 D., Cl. Sed., D3, D4, Lower, PKG. Right	1	2084 774	2084 774	----	----	----
	Left	1	2084 775	2084 775	----	----	----
	CLIP	12	6000 693	6000 693	----	----	----
	Sp. Cl. Cp., w/High Window, Side, PKG. Right	1	2084 780	----	----	----	----
	Left	1	2084 781	----	----	----	----
	CLIP	10	6000 692	----	----	----	----
	Sp. Cl. Cp., Upper, PKG. CLIP	1	2084 784	----	----	----	----
		7	6000 692	----	----	----	----
	Sp. Cl. Cp., D3, D4, Lower, PKG. CLIP	1	2084 785	2084 785	----	----	----
		7	6000 693	6000 693	----	----	----
	Sp. 4 D., D3, D4, w/High Window, Lower End, PKG. Right	1	----	2196 274	----	----	----
	Left	1	----	2196 275	----	----	----
	CLIP	2	----	6000 721	----	----	----
	Sp. 4 D., D1, D2, w/High Window, Upper and Side, PKG. Right	1	----	2196 288	----	----	----
	Left	1	----	2196 289	----	----	----
	CLIP	10	----	6000 692	----	----	----
	Lower End, PKG. Right	1	----	2196 278	----	----	----
	Left	1	----	2196 279	----	----	----
	CLIP	2	----	6000 773	----	----	----
	Sp. Cl. Cp., w/High Window, Upper and Side, PKG. Right	1	----	----	*2196 808	*2196 808	----
	Left	1	----	----	2196 809	2196 809	----
	CLIP	12	----	----	6000 692	6000 692	----
	4 D., Sp. 4 D., D1, D2, w/Low Window, Upper and Side, PKG. Right	1	----	2196 282	2196 282	2196 282	----
	Left	1	----	2196 283	2196 283	2196 283	----
	CLIP	10	----	6000 692	6000 692	6000 692	----
	PKG. Lower	1	----	2196 292	2196 292	2196 292	----
	CLIP	14	----	6000 689	6000 689	6000 689	----
	Lower End, PKG. Right	1	----	2196 284	2196 284	2196 284	----
	Left	1	----	2196 285	2196 285	2196 285	----
	CLIP	2	----	6000 773	6000 773	6000 773	----
	CLIP	2	----	6008 084	6008 084	6008 084	----
	SCREW	2	----	161 592	161 592	161 592	----
	SCREW	2	----	125 675	125 675	125 675	----
	Sp. Cl. Cp., D1, D2, PKG. Lower	1	----	2196 293	----	----	----
	CLIP	10	----	6000 689	----	----	----
	Sp. Cl. Cp., PKG., w/High Window, Lower Center	1	----	----	*2196 812	*2196 812	----
	Sp. Cl. Cp., PKG., w/High Window, Lower Side, Right	1	----	----	*2196 810	*2196 810	----
	Left	1	----	----	2196 811	2196 811	----
	Sp. 4 D., S3, w/High Window, Upper and Side, PKG. Right	1	----	----	2196 288	----	----
	Left	1	----	----	2196 289	----	----
	CLIP	10	----	----	6000 692	----	----
	Lower End, PKG. Right	1	----	----	2196 286	----	----
	Left	1	----	----	2196 287	----	----

★ Indicates use as required.

☐ Indicates parts not listed in any previous parts book.

Dec. 9, 1960 Supersedes April 20, 1960.

Printed in U.S.A.
Prices and specifications subject to change without notice.

* Indicates change or addition.

CODE	REMARKS	PER CAR	PLYMOUTH	DODGE	DESOTO	CHRYSLER	IMPERIAL
23-23-0 OUTSIDE FINISH MOULDING-Cont'd							
23-23-52	MOULDING - Cont'd						
	CLIP	2	----	----	6000 773	----	----
	CLIP	2	----	----	6000 688	----	----
	SCREW	2	----	----	161 592	----	----
	SCREW	2	----	----	125 675	----	----
	4 D., Sp. 4 D., w/High Window, Upper and Side, PKG.						
	Right	1	----	----	----	2196 288	----
	Left	1	----	----	----	2196 289	----
	CLIP	10	----	----	----	6000 692	----
	Lower End, PKG.						
	Right	1	----	----	----	2196 286	----
	Left	1	----	----	----	2196 287	----
	CLIP	2	----	----	----	6000 773	----
	CLIP	2	----	----	----	6000 688	----
	SCREW	2	----	----	----	125 675	----
	SCREW	2	----	----	----	161 592	----
	4 D., Sp. 4 D., Y1-L, Y1-M, PKG.						
	Upper	1	----	----	----	----	2196 822
	Side, Right	1	----	----	----	----	2196 824
	Left	1	----	----	----	----	2196 825
	CLIP	24	----	----	----	----	6006 201
	PKG.						
	Lower, Right	1	----	----	----	----	2196 690
	Left	1	----	----	----	----	2196 691
	CLIP	18	----	----	----	----	6006 200
	4 D., Sp. 4 D., Y1-H						
	Right	1	----	----	----	----	1961 516
	Left	1	----	----	----	----	1961 517
	Sp. Cl. Cp., PKG.						
	Upper	1	----	----	----	----	2196 823
	Side, Right	1	----	----	----	----	2196 826
	Left	1	----	----	----	----	2196 827
	CLIP	24	----	----	----	----	6006 201
	PKG.						
	Lower, Right	1	----	----	----	----	2196 688
	Left	1	----	----	----	----	2196 689
	CLIP	16	----	----	----	----	6006 200
23-23-60	MOULDING, Tailgate Opening Outside Finish Sub., PKG.						
	Roof Rear	1	2196 466	2196 466	----	2196 466	----
	CLIP	14	6006 451	6006 451	----	6006 451	----
	CAP, PKG.						
	Right	1	2196 464	2196 464	----	2196 464	----
	Left	1	2196 465	2196 465	----	2196 465	----
	CLIP	2	6006 451	6006 451	----	6006 451	----
	Rear Upper Pillar, PKG.						
	Right	1	2196 462	2196 462	----	2196 462	----
	Left	1	2196 463	2196 463	----	2196 463	----
	CLIP	4	6006 451	6006 451	----	6006 451	----
23-23-61	MOULDING PACKAGE, Tailgate Outside Finish Belt, Sub.						
		1	2196 460	2196 460	----	2196 460	----
	SCREW	5	178 790	178 790	----	178 790	----
	CLIP	2	6006 441	6006 441	----	6006 441	----
	SCREW	2	151 306	151 306	----	151 306	----
	Sub., Lower						
	SCREW	7	----	*2196 458	----	----	----
	CLIP	7	----	167 834	----	----	----
	Sp. 4 D. Sub., Lower						
	CLIP	1	----	6006 458	----	2196 468	----
	SCREW	7	----	----	----	6006 457	----
	SCREW	7	----	----	----	167 834	----
23-23-64	PANEL, Windshield Header Outside Finish Cv. Cp., PKG.						
	SCREW	1	2196 119	2196 119	----	2196 119	----
	SCREW	5	274 109	274 109	----	274 109	----
23-23-65	MOULDING, Windshield Outside Finish Cv. Cp., Side, w/EXTENSION, PKG.						
	Right	1	2084 998	2084 998	----	2084 998	----
	Left	1	2084 999	2084 999	----	2084 999	----
	SCREW	2	274 109	274 109	274 109	274 109	----
	Except Cv. Cp., PKG.						
	Upper	1	2196 873	2196 873	2196 873	2196 873	----
	CLIP	7	6000 742	6000 742	6000 742	6000 742	----
	Except Cv. Cp., Side, PKG.						
	Right	1	2196 270	2196 270	2196 270	2196 270	----
	Left	1	2196 271	2196 271	2196 271	2196 271	----
	SCREW	8	6000 009	6000 009	6000 009	6000 009	----

★ Indicates use as required.

☐ Indicates parts not listed in any previous parts book.

* Indicates change or addition.

CODE	REMARKS	PER CAR	PLYMOUTH	DODGE	DESOTO	CHRYSLER	IMPERIAL
23-23-0 OUTSIDE FINISH MOULDING-Cont'd							
23-23-65	MOULDING - Cont'd						
	Lower Center, PKG.	1	2084 997	2084 997	2084 997	2084 997	----
	CLIP	5	6000 685	5000 685	6000 685	6000 685	----
	Lower End, PKG.	Right 1	2196 272	2196 272	2196 272	2196 272	----
		Left 1	2196 273	2196 273	2196 273	2196 273	----
	CLIP	2	6000 685	6000 685	6000 685	6000 685	----
	4 D., Sp. 4 D., Sp. Cl. Cp., Upper, PKG.	Right 1	----	----	----	----	2196 474
		Left 1	----	----	----	----	2196 475
	RETAINER	2	----	----	----	----	6006 338
	RETAINER	4	----	----	----	----	6006 414
	Side, PKG.	Right 1	----	----	----	----	2196 472
		Left 1	----	----	----	----	2196 473
	SCREW	8	----	----	----	----	6000 000
	Cv. Cp., PKG.	Upper 1	----	----	----	----	2196 749
	STUD	5	----	----	----	----	6006 176
	RETAINER	5	----	----	----	----	6006 434
	Header, Upper Corner, PKG.	Right 1	----	----	----	----	2196 673
		Left 1	----	----	----	----	2196 674
	Side, PKG.	Right 1	----	----	----	----	2196 481
		Left 1	----	----	----	----	2196 482
	SCREW	6	----	----	----	----	6000 000
	Lower, PKG.	Right 1	----	----	----	----	2196 477
		Left 1	----	----	----	----	2196 478
	CLIP	20	----	----	----	----	6006 200
23-23-66	CAP, Windshield Outside Finish Moulding Joint						
	4 D., Sp. 4 D., Sp. Cl. Cp., PKG. Upper Center	1	----	----	----	----	2196 476
	SEAL	1	----	----	----	----	1961 286
		Lower Center 1	----	----	----	----	1692 191
23-23-73	MOULDING, Quarter Window Outside Finish						
	Sub.	Lower Right 1	1961 214	1961 214	----	1961 214	----
		Left 1	1961 215	1961 215	----	1961 215	----
	Sub.	Upper Right 1	1961 212	1961 212	----	1961 212	----
		Left 1	1961 213	1961 213	----	1961 213	----
	Sub.	Front Right 1	2094 018	2094 018	----	2094 018	----
		Left 1	2094 019	2094 019	----	2094 019	----
23-23-74	CAP, Quarter Window Outside Finish Moulding						
	Sub., w/RETAINER	Front Upper Right 1	2094 016	2094 016	----	2094 016	----
		Left 1	2094 017	2094 017	----	2094 017	----
	Sub., PKG.	Lower Rear Right 1	2196 816	2196 816	----	2196 816	----
		Left 1	2196 817	2196 817	----	2196 817	----
23-23-80	PANEL, Door Outside Finish						
	4D., Sp. 4D., D3-M, D4-M, Rear Door	Right 1	----	1963 126	----	----	----
		Left 1	----	1963 127	----	----	----
	4D., Sp. 4D., D3-H, D4-H, Rear Door	Right 1	----	1963 110	----	----	----
		Left 1	----	1963 111	----	----	----
	PLATE, Door Outside Finish						
	4D., Sub., D3, D4, PKG.	Right 1	----	2196 438	----	----	----
		Left 1	----	2196 439	----	----	----
	SCREW	4	----	9414 078	----	----	----
23-23-85	PANEL, Quarter Panel Outside Finish						
	4D., Sp. 4D., D3-H, D4-H	Right 1	----	1963 112	----	----	----
		Left 1	----	1963 113	----	----	----
	Sp. Cl. Cp., Cl. Sed., D3-M, D4-M	Right 1	----	1963 126	----	----	----
		Left 1	----	1963 127	----	----	----
	Sp. Cl. Cp., Cv. Cp., D4-H, Y1-M	Right 1	----	1963 114	----	----	----
		Left 1	----	1963 115	----	----	----
23-23-86	INSERT, Quarter Panel Outside Finish Top						
	Rear Moulding						
	Sp. Cl. Cp., 4D., Sp. 4D., D1, PKG., Chrome	2	----	*2196 417	----	----	----
	NUT	2	----	151 497	----	----	----
	Sp. Cl. Cp., Cv. Cp., 4D., Sp. 4D., D2, PKG., Plastic	2	----	*2196 416	----	----	----
	NUT	2	----	151 497	----	----	----

★ Indicates use as required.

⊠ Indicates parts not listed in any previous parts book.

Dec. 9, 1960 Supersedes April 20, 1960.

Page 23-66

Printed in U.S.A.
Prices and specifications subject to change without notice.

* Indicates change or addition.

CODE	REMARKS	PER CAR	PLYMOUTH	DODGE	DESOTO	CHRYSLER	IMPERIAL
23-26-O TRIM FINISH MOULDINGS							
23-26-2	MOULDING, Rear Quarter Arm Rest						
	Sp. Cl. Cp., P2-H	2	1868 886	----	----	----	----
	Sp. Cl. Cp., P1-H, P2-H, Mylar Tape	2	*2194 110	----	----	----	----
	Sp. Cl. Cp., Cv. Cp., Y1-M, Right	2	----	----	----	----	*2085 826
	Left	2	----	----	----	----	*2085 827
	Sp. Cl. Cp., S3, Right	1	----	----	2080 396	----	----
	Left	1	----	----	2080 397	----	----
23-26-23	MOULDING, Door Trim Panel						
	4D., Sp.4D., 4D. Sub., P1-H, P2-H Rear	2	1867 583	----	----	----	----
	Cl. Sed., P1-L, P2-L, P1-M, P2-M	2	1778 529	----	----	----	----
	Cl. Sed., Sp. Cl. Cp., P1-M, P2-M	2	1977 408	----	----	----	----
	4 D. Sub., P1-M, P2-M, Right	1	1977 404	----	----	----	----
	Left	1	1977 405	----	----	----	----
	4 D., 4 D. Sub., P1-M, P2-M Front	2	1977 407	----	----	----	----
	4 D., P1-M, P2-M Rear Right	1	1977 402	----	----	----	----
	Left	1	1977 403	----	----	----	----
	Cl. Sed., Sp. Cl. Cp., 4D., Sp. 4D., 4D. Sub., Sp. 4D. Sub., P1-H, P2-H, Mylar Tape, Front Door Arm Rest	2	⊠2194 109	----	----	----	----
	4D., Sp. 4D., 4D. Sub., Sp. 4D. Sub., P1-H, P2-H, Mylar Tape, Rear Door Arm Rest	2	⊠2194 109	----	----	----	----
	Cl. Sed., Sp. Cl. Cp., D3, D4, Upper and Lower, Right	2	----	2192 648	----	----	----
	Left	2	----	2192 649	----	----	----
	Sp. Cl. Cp., Cv. Cp., D2, Upper Center, Right	1	----	2192 120	----	----	----
	Left	1	----	2192 121	----	----	----
	4 D., 4 D. Sub., D1, D2, Front Center Upper, Right	1	----	2192 116	----	----	----
	Left	1	----	2192 117	----	----	----
	Sp. 4 D., Sp. 4 D. Sub., D1, D2, Front Center Upper, Right	1	----	2192 118	----	----	----
	Left	1	----	2192 119	----	----	----
	Sp. 4 D., Sp. 4 D. Sub., D1, D2, Front Center, Lower	2	----	2192 123	----	----	----
	Sp. Cl. Cp., Cv. Cp., D1, D2, Center, Lower	2	----	2192 124	----	----	----
	4 D., 4 D. Sub., D1, D2, Rear Center, Lower	2	----	2192 126	----	----	----
	Sp. 4D., Sp. 4D. Sub., D1, D2, Rear Center, Lower	2	----	2192 127	----	----	----
	4 D., Sp. 4 D., Sp. 4 D. Sub., D1, D2, Rear Center, Upper	2	----	2192 125	----	----	----
	Sp. Cl. Cp., Cv. Cp., D1, D2, Right	1	----	2192 114	----	----	----
	Left	1	----	2192 115	----	----	----
	Sp. 4 D., Sp. 4 D. Sub., D1, D2, Front, Right	1	----	2192 112	----	----	----
	Left	1	----	2192 113	----	----	----
	4 D., 4 D. Sub., D1, D2, Front, Right	1	----	2192 110	----	----	----
	Left	1	----	2192 111	----	----	----
	4D., 4D. Sub., D1, D2, Front Center, Lower	2	----	2192 122	----	----	----
	Sp. 4 D., D1, Front Upper, Right	1	----	1974 114	----	----	----
	Left	1	----	1974 115	----	----	----
	Sp. 4 D., D1, Front Lower, Right	1	----	1974 118	----	----	----
	Left	1	----	1974 119	----	----	----
	Sp. 4 D., D1, Rear Lower, Right	1	----	1974 106	----	----	----
	Left	1	----	1974 107	----	----	----
	4 D., 4 D. Sub., D1, Rear Lower, Right	1	----	1974 122	----	----	----
	Left	1	----	1974 123	----	----	----
	Sp. 4 D., Sp. 4 D. Sub., D2, Rear Upper, Right	1	----	1974 772	----	----	----
	Left	1	----	1974 773	----	----	----
	Sp. 4 D., Sp. 4 D. Sub., D2, Rear Lower, Right	1	----	1974 774	----	----	----
	Left	1	----	1974 775	----	----	----
	4 D., D3-M, D4-M, Rear Lower, Right	1	----	1974 784	----	----	----
	Left	1	----	1974 785	----	----	----
	4 D., D3-M, D4-M, Rear Upper	2	----	1974 767	----	----	----
	4 D. Sub., D3-M, D4-M, Rear Upper	2	----	1974 097	----	----	----

★ Indicates use as required.

⊠ Indicates parts not listed in any previous parts book.

* Indicates change or addition.

Printed in U.S.A.

Prices and specifications subject to change without notice.

1960 PASSENGER CAR PARTS CATALOG

BODY

CODE	REMARKS	PER CAR	PLYMOUTH	DODGE	DESOTO	CHRYSLER	IMPERIAL
23-26-O TRIM FINISH MOULDINGS - Cont'd							
23-26-23	MOULDING - Cont'd						
4 D. Sub., D3-M, D4-M	Rear Lower Right	1	----	1974 120	----	----	----
	Left	1	----	1974 121	----	----	----
Sp. Cl. Cp., D1	Upper Right	1	----	1974 108	----	----	----
	Left	1	----	1974 109	----	----	----
4 D., 4 D. Sub., D1	Rear Upper	2	----	1974 105	----	----	----
Sp. 4 D., D1	Rear Upper	2	----	1974 104	----	----	----
Sp. Cl. Cp., D1	Lower Right	1	----	1974 110	----	----	----
	Left	1	----	1974 111	----	----	----
4 D., 4 D. Sub., D1	Front Upper Right	1	----	1974 112	----	----	----
	Left	1	----	1974 113	----	----	----
4 D., 4 D. Sub., D1	Front Lower Right	1	----	1974 116	----	----	----
	Left	1	----	1974 117	----	----	----
4 D., D2, Front Center	Lower	2	----	2192 122	----	----	----
4 D., D2, Front Center	Upper Right	1	----	2192 116	----	----	----
	Left	1	----	2192 117	----	----	----
4 D., 4 D. Sub., D3, D4	Front Right	1	----	2192 650	----	----	----
	Left	1	----	2192 651	----	----	----
4 D. Sub., D1	Rear Upper	2	----	1974 776	----	----	----
4 D. Sub., D1	Rear Lower Right	1	----	1974 778	----	----	----
	Left	1	----	1974 779	----	----	----
4 D., D2	Rear Upper	2	----	1974 776	----	----	----
4 D., D2	Rear Lower Right	1	----	1974 778	----	----	----
	Left	1	----	1974 779	----	----	----
4 D., Sp. 4 D., Sub., D2, Rear Center	Upper	2	----	2192 125	----	----	----
Sp. Cl. Cp., Cv. Cp., D2, Center	Lower	2	----	2192 124	----	----	----
Cl. Sed., Sp. Cl. Cp., D3, D4	Right	1	----	2192 648	----	----	----
	Left	1	----	2192 649	----	----	----
Sub., D1, Rear Center	Lower	2	----	2192 126	----	----	----
4 D., D2, Rear Center	Lower	2	----	2192 126	----	----	----
Sp. 4 D., D1, Rear Center	Upper	2	----	2192 125	----	----	----
4 D., Sp. 4 D., Sub., D2, Rear Center	Upper	2	----	2192 125	----	----	----
Sp. Cl. Cp., Sp. 4 D., S3, Arm Rest	Right	★	----	----	2080 394	----	----
	Left	★	----	----	2080 395	----	----
Sp. 4D	Lower	2	----	----	1647 239	----	----
Sp. 4 D., S3, Rear Intermediate		2	----	----	2085 170	----	----
Sp. Cl. Cp., S1	Right	1	----	----	2085 250	----	----
	Left	1	----	----	2085 251	----	----
4 D., Sp. 4 D., S1, Rear Upper		2	----	----	2085 492	----	----
4 D., Sp. 4D., S3, Rear Lower	Right	1	----	----	2085 172	----	----
	Left	1	----	----	2085 173	----	----
Sp. 4 D., S3, Front Upper	Right	1	----	----	2085 158	----	----
	Left	1	----	----	2085 159	----	----
4 D., S1, S3	Front Right	1	----	----	2085 246	----	----
	Left	1	----	----	2085 247	----	----
Sp. Cl. Cp., S3	Upper Right	1	----	----	2085 090	----	----
	Left	1	----	----	2085 091	----	----
Sp. Cl. Cp., S3	Lower	2	----	----	2085 800	----	----
4 D., S3, Front Intermediate	Right	1	----	----	2085 130	----	----
	Left	1	----	----	2085 131	----	----
Sp. 4 D., S1	Front Right	1	----	----	2085 248	----	----
	Left	1	----	----	2085 249	----	----
Sp. Cl. Cp., Rr. Quarter Arm Rest	Right	1	----	----	2080 396	----	----
	Left	1	----	----	2080 397	----	----
Sp. Cl. Cp., Cv. Cp., 4 D., Sp. 4 D., Sp. 4 D. Sub., C1-L	Front, Right	1	----	----	----	1900 922	----
	Left	1	----	----	----	1900 923	----
Sp. Cl. Cp., 4D., Sp. 4D., C2-M	Front Lower Right	1	----	----	----	1900 922	----
	Left	1	----	----	----	1900 923	----
Sp. 4 D., Sp. 4 D. Sub., C1-L	Rear Right	1	----	----	----	1900 972	----
	Left	1	----	----	----	1900 973	----
Sp. 4D., C2-M	Rear Lower Right	1	----	----	----	1900 972	----
	Left	1	----	----	----	1900 973	----
4D., C1-L	Rear Right	1	----	----	----	1900 958	----
	Left	1	----	----	----	1900 959	----

★ Indicates use as required.

⊞ Indicates parts not listed in any previous parts book.

Dec. 9, 1960 Supersedes April 20, 1960.

Printed in U.S.A.
Prices and specifications subject to change without notice.

* Indicates change or addition.

CODE	REMARKS	PER CAR	PLYMOUTH	DODGE	DESOTO	CHRYSLER	IMPERIAL
23-26-O TRIM FINISH MOULDINGS-Cont'd							
23-26-23	MOULDING - Cont'd						
	4D., C2-M						
	Rear Lower Right	1	----	----	----	1900 958	----
	Left	1	----	----	----	1900 959	----
	4 D., Sp. 4 D., Sp. 4 D. Sub., C3, Rear						
	Lower Right	1	----	----	----	2085 714	----
	Left	1	----	----	----	2085 715	----
	C3						
	Front Upper Right	1	----	----	----	2085 470	----
	Left	1	----	----	----	2085 471	----
	4 D., Sp. 4 D., C2						
	Rear Upper Right	1	----	----	----	2085 012	----
	Left	1	----	----	----	2085 013	----
	Sp. 4D., C1						
	Rear Upper Right	1	----	----	----	2085 012	----
	Left	1	----	----	----	2085 013	----
	4 D., C2						
	Front Upper Right	1	----	----	----	1900 984	----
	Left	1	----	----	----	1900 985	----
	Sp. Cl. Cp., Cv. Cp., Sp. 4 D., C1, C2, Front						
	Upper Right	1	----	----	----	1900 984	----
	Left	1	----	----	----	1900 985	----
	Sp. Cl. Cp., Cv. Cp., C3						
	Lower	2	----	----	----	2085 800	----
	4 D., C3						
	Front Lower	2	----	----	----	2085 709	----
	4 D., Sp. 4 D., Sub., C3, Rear Upper						
	Right	1	----	----	----	2085 480	----
	Left	1	----	----	----	2085 481	----
	Sp. 4D., Sub., C3						
	Front Lower	2	----	----	----	2085 475	----
	4 D., Y1-L, Front Door						
	Upper Right	1	----	----	----	----	2085 756
	Left	1	----	----	----	----	2085 757
	DOOR/PULL						
	Right	1	----	----	----	----	2085 660
	Left	1	----	----	----	----	2085 661
	SCREW, No. 8-15 x 1"	6	----	----	----	----	148 095
	GROMMET	2	----	----	----	----	2085 862
	STOP						
	Upper and Lower Rear	4	----	----	----	----	2080 982
	Rear Door, CAP						
	Right	1	----	----	----	----	1830 498
	Left	1	----	----	----	----	1830 499
	SCREW, No. 8-15 x 3/4"	2	----	----	----	----	162 402
	Upper Right	1	----	----	----	----	2085 774
	Left	1	----	----	----	----	2085 775
	SCREW, No. 8-15 x 1"	6	----	----	----	----	148 095
	GROMMET	2	----	----	----	----	2085 862
	4D., Y1-M, Front Door						
	Upper Right	1	----	----	----	----	2085 756
	Left	1	----	----	----	----	2085 757
	BEZEL and PLATE	2	----	----	----	----	2085 854
	DOOR/PULL, Arm Rest						
	Right	1	----	----	----	----	2085 660
	Left	1	----	----	----	----	2085 661
	SCREW, No. 8-15 x 1"	6	----	----	----	----	148 095
	GROMMET	2	----	----	----	----	2085 862
	Lower Right	1	----	----	----	----	2085 784
	Left	1	----	----	----	----	2085 785
	STOP						
	Upper and Lower Rear	4	----	----	----	----	2080 982
	Rear Door, CAP						
	Rear Upper Right	1	----	----	----	----	1830 498
	Left	1	----	----	----	----	1830 499
	Upper Right	1	----	----	----	----	2085 774
	Left	1	----	----	----	----	2085 775
	BEZEL and PLATE	2	----	----	----	----	2085 854
	Sp. Cl. Cp., Y1-L						
	Front Upper Right	1	----	----	----	----	2080 052
	Left	1	----	----	----	----	2080 053
	RIVET, 1/8 x 7/32"	8	----	----	----	----	136 028
	SCREW, No. 8-15 x 5/8"	2	----	----	----	----	145 417
	Upper Right	1	----	----	----	----	2085 758
	Left	1	----	----	----	----	2085 759
	DOOR/PULL, Arm Rest						
	Right	1	----	----	----	----	2085 660
	Left	1	----	----	----	----	2085 661
	SCREW, No. 8-15 x 1"	6	----	----	----	----	148 095
	GROMMET	2	----	----	----	----	2085 862
	Sp. Cl. Cp., Cv. Cp., Y1-M						
	Upper Right	1	----	----	----	----	2085 758
	Left	1	----	----	----	----	2085 759
	BEZEL and PLATE	2	----	----	----	----	2085 854
	DOOR/PULL, Arm Rest						
	Right	1	----	----	----	----	2085 660
	Left	1	----	----	----	----	2085 661

★ Indicates use as required.

☐ Indicates parts not listed in any previous parts book.

* Indicates change or addition.

1960 PASSENGER CAR PARTS CATALOG

CODE	REMARKS	PER CAR	PLYMOUTH	DODGE	DESOTO	CHRYSLER	IMPERIAL
23-26-0 TRIM FINISH MOULDINGS-Cont'd							
23-26-23	MOULDING - Cont'd						
	SCREW, No. 8-15 x 1"	6	----	----	----	----	148 095
	GROMMET	2	----	----	----	----	2085 862
	Lower	2	----	----	----	----	2085 792
	4 D., Sp. 4 D., Front Door	1	----	----	----	----	2085 756
	Upper Right	1	----	----	----	----	2085 757
	Left	1	----	----	----	----	
	4 D., Sp. 4 D., Y1-M, Y1-H, Front Door						
	Lower Right	1	----	----	----	----	2085 784
	Left	1	----	----	----	----	2085 785
	Sp. Cl. Cp., Cv. Cp., 4 D., Sp. 4 D, Y1-M, Front Door, BEZEL and Finish PLATE	2	----	----	----	----	2085 854
	Sp. Cl. Cp., Cv. Cp., 4 D., Sp. 4 D., Y1-M, Y1-H, Front Door BEZEL	2	----	----	----	----	2085 856
	4 D., Sp. 4 D., Y1-H, Front Door BEZEL and Finish PLATE	1	----	----	----	----	2085 850
	Right	1	----	----	----	----	2085 851
	Left	1	----	----	----	----	
	4 D., Sp. 4 D., Rear Door	1	----	----	----	----	2085 774
	Upper Right	1	----	----	----	----	2085 775
	Left	1	----	----	----	----	2085 788
	4 D., Sp. 4 D., Y1-M, Y1-H, Rear Door Lower	2	----	----	----	----	
	4 D., Sp. 4 D., Y1-M, Rear Door BEZEL and Finish PLATE	2	----	----	----	----	2085 854
	4 D., Sp. 4 D., Y1-M, Y1-H, Front Door BEZEL	2	----	----	----	----	2085 856
	4 D., Sp. 4 D., Y1-H, Rear Door BEZEL and Finish PLATE	1	----	----	----	----	2085 850
	Right	1	----	----	----	----	2085 851
	Left	1	----	----	----	----	
23-26-34	MOULDING, Front Seat Back Trim						
	4 D., Sp. 4 D., Y1-M, Y1-H, w/o Swivel Seat	1	----	----	----	----	2086 362
	Sp. Cl. Cp., Cv. Cp., Y1-M, w/o Swivel Seat Rt.	1	----	----	----	----	*2086 360
	Lt.	1	----	----	----	----	*1900 762
23-26-41	MOULDING, Roof Side Rail Inside Finish						
	Sp. 4 D., P1-H, P2-H, D3, D4, Stainless Steel						
	Right	1	1964 280	1964 280	----	----	----
	Left	1	1964 281	1964 281	----	----	----
	Sp. 4 D., D1, D2, S1, C1, Prime						
	Right	1	----	1882 946	1882 946	1882 946	----
	Left	1	----	1882 947	1882 947	1882 947	----
	SCREW	10	----	9413 273	9413 273	9413 273	----
	Sp. 4 D., D2-H, C3, w/Custom Trim Stainless Steel						
	Right	1	----	1954 862	1954 862	1954 862	----
	Left	1	----	1954 863	1954 863	1954 863	----
	Sp. Cl. Cp., P1-M, P2-M, D1, D3-M, D4-M, Prime						
	Right	1	1882 950	1882 950	----	----	----
	Left	1	1882 951	1882 951	----	----	----
	Sp. Cl. Cp., P1-H, P2-H, D2-H, D3-H, D4-H, Stainless Steel						
	Right	1	1954 930	1954 930	----	----	----
	Left	1	1954 931	1954 931	----	----	----
	Sp. Cl. Cp., Prime						
	Right	1	----	----	1839 936	1839 936	----
	Left	1	----	----	1839 937	1839 937	----
	Sp. Cl. Cp., C2, C3, Stainless Steel						
	Right	1	----	----	2086 058	2086 058	----
	Left	1	----	----	2086 059	2086 059	----
	2 D. Sub., 4 D. Sub., Prime						
	Right	1	1902 308	1902 308	----	----	----
	Left	1	1902 309	1902 309	----	----	----
	Sp. 4 D. Sub., D2, C1, Prime						
	Right	1	----	1882 946	----	1882 946	----
	Left	1	----	1882 947	----	1882 947	----
	Sp. 4 D. Sub., D2, Stainless Steel						
	Right	1	----	1954 862	----	----	----
	Left	1	----	1954 863	----	----	----
	Sp. 4 D. Sub., C3						
	Right	1	----	----	----	1954 862	----
	Left	1	----	----	----	1954 863	----
	Sp. 4 D., Chrome						
	Front Right	1	----	----	----	----	1901 978
	Left	1	----	----	----	----	1901 979
	Rear Right	1	----	----	----	----	1901 982
	Left	1	----	----	----	----	1901 983

★ Indicates use as required.

☐ Indicates parts not listed in any previous parts book.

Dec. 9, 1960 Supersedes April 20, 1960.

Printed in U.S.A.

Prices and specifications subject to change without notice.

* Indicates change or addition.

CODE	REMARKS	PER CAR	PLYMOUTH	DODGE	DESOTO	CHRYSLER	IMPERIAL
23-26-0 TRIM FINISH MOULDINGS-Cont'd							
23-26-41	MOULDING - Cont'd						
	Sp. Cl. Cp., Chrome						
	Front Right	1	----	----	----	----	1901 980
	Left	1	----	----	----	----	1901 981
	Rear Right	1	----	----	----	----	1901 984
	Left	1	----	----	----	----	1901 985
	EXTENSION, Roof Side Rail Inside Finish Moulding						
	2 D.Sub., 4 D. Sub., Prime						
	Front Right	1	1902 348	1902 348	----	----	----
	Left	1	1902 349	1902 349	----	----	----
	Sp. 4D., Sp. 4D. Sub., Sp. Cl. Cp., S1, Prime						
	Front						
	Right	1	*1952 880	*1952 880	*1952 880	*1952 880	----
	Left	1	1952 881	1952 881	1952 881	1952 881	----
	Sp. Cl. Cp., Prime						
	Rear Right	1	1954 644	1954 644	----	----	----
	Left	1	1954 645	1954 645	----	----	----
	Sp. Cl. Cp., Stainless Steel						
	Rear Right	1	1963 640	1963 640	----	----	----
	Left	1	1963 641	1963 641	----	----	----
	Sp. 4 D., Sp. Cl. Cp., D2-H, D3-H, D4-H, C3, Sp. 4D. Sub., w/Custom Trim, Stainless Steel						
	Front Right	1	*1952 896	*1952 896	*1952 896	*1952 896	----
	Left	1	1952 897	1952 897	1952 897	1952 897	----
23-26-42	CAP, Roof Rail Inside Finish Extension Moulding, Sp. Cl. Cp.						
	Right	1	2163 468	----	----	----	----
	Left	1	2163 469	----	----	----	----
23-26-44	SUPPORT, Roof Rail Inside Finish Moulding						
	Sp. 4D., Sp. 4 D. Sub., D1, D2						
	Right	1	1869 564	1869 564	1869 564	1869 564	----
	Left	1	1869 565	1869 565	1869 565	1869 565	----
	Sp. 4 D., D3, D4						
	Right	1	*1869 860	*1869 860	----	----	----
	Left	1	*1869 861	*1869 861	----	----	----
	Sp. Cl. Cp.						
	Right	1	1869 858	1869 858	1878 440	1878 440	----
	Left	1	1869 859	1869 859	1878 441	1878 441	----
23-26-45	MOULDING, Front Seat Side Shield						
	4D., Sp. 4D., Y1-M, Y1-H, w/o Swivel Seats						
	Right	1	----	----	----	----	2080 382
	Left	1	----	----	----	----	2080 383
	Sp. Cl. Cp., Cv. Cp., Y1-M, w/o Swivel Seats						
	Upper Right	1	----	----	----	----	2080 384
	Left	1	----	----	----	----	2080 385
	Lower Right	1	----	----	----	----	2080 386
	Left	1	----	----	----	----	2080 387
23-26-46	FINISH PLATE, Rear Quarter Trim Panel						
	Sp. Cl. Cp., C3-H,						
	Right	1	----	----	----	E2085 590	----
	Left	1	----	----	----	E2085 591	----
	Cv. Cp., C3-H,						
	Right	1	----	----	----	E2085 602	----
	Left	1	----	----	----	E2085 603	----
23-26-47	MOULDING, Rear Quarter Trim Panel Finish						
	Cl. Sed., Sp. Cl. Cp., P1-M, P2-M						
	Sp. 4 D. Sub., Wheelhouse						
	Front Upper Right	1	----	2080 644	----	2080 644	----
	Left	1	----	2080 645	----	2080 645	----
	4D., Sub., Wheelhouse						
	Front Upper Right	1	2080 440	2080 440	----	----	----
	Left	1	2080 441	2080 441	----	----	----
	4D. Sub., Sp. 4D. Sub., Wheelhouse						
	Front Lower Right	1	2080 438	2080 438	----	2080 438	----
	Left	1	2080 439	2080 439	----	2080 439	----
	2 D. Sub., Wheelhouse						
	Front Right	1	2080 544	----	----	----	----
	Left	1	2080 545	----	----	----	----
	Sp. Cl. Cp., D1, D2						
	Upper	2	----	1974 765	----	----	----
	Lower	2	----	1974 766	----	----	----
	Sp. Cl. Cp., D3-M, D4-M						
	Upper	2	----	1974 095	----	----	----
	Lower	2	----	1974 096	----	----	----
	Sp. Cl. Cp., D1, D2, Center						
	Upper	2	----	2192 128	----	----	----
	Lower	2	----	2192 129	----	----	----
	Cl. Sed., D3-M, D4-M						
	Upper	2	----	1974 093	----	----	----
	Lower	2	----	1974 094	----	----	----
	Cv. Cp., D2-H						
	Upper Right	1	----	1974 768	----	----	----
	Left	1	----	1974 769	----	----	----
	Lower Right	1	----	1974 770	----	----	----
	Left	1	----	1974 771	----	----	----

★ Indicates use as required.

☐ Indicates parts not listed in any previous parts book.

* Indicates change or addition.

Printed in U.S.A.

Prices and specifications subject to change without notice.

CODE	REMARKS	PER CAR	PLYMOUTH	DODGE	DESOTO	CHRYSLER	IMPERIAL
23-26-O TRIM FINISH MOULDINGS - Cont'd							
23-26-47	MOULDING - Cont'd						
	Cv. Cp., D2, Center						
	Upper	2	----	2192 130	----	----	----
	Lower	2	----	2192 131	----	----	----
	Cv. Cp., D2						
	Upper Right	1	----	1974 768	----	----	----
	Left	1	----	1974 769	----	----	----
	Sp. Cl. Cp., S1	2	----	----	2085 493	----	----
	Sp. Cl. Cp., S3	2	----	----	2085 108	----	----
	Sp. Cl. Cp., C1, C2	2	----	----	----	2085 446	----
	Sp. Cl. Cp., Cv. Cp., C3	2	----	----	----	1647 087	----
	Sp. Cl. Cp., C3-300	2	----	----	----	1876 338	----
	4D., Sp. 4D.						
	Right	1	----	----	----	----	2085 844
	Left	1	----	----	----	----	2085 845
	Sp. Cl. Cp.	2	----	----	----	----	2085 778
	Cv. Cp., C1	2	----	----	----	2085 958	----
	Cv. Cp., C3						
	Upper Right	1	----	----	----	2085 478	----
	Left	1	----	----	----	2085 479	----
	Cv. Cp., C1	2	----	----	----	2085 445	----
	Cv. Cp., C3	2	----	----	----	2086 177	----
	Sp. Cl. Cp., C3-300	2	----	----	----	2086 338	----
	Sp. Cl. Cp., C1, C2						
	Upper Right	1	----	----	----	2085 234	----
	Left	1	----	----	----	2085 235	----
	Sp. Cl. Cp., C3						
	Upper Right	1	----	----	----	2085 480	----
	Left	1	----	----	----	2085 481	----
	Cv. Cp.	2	----	----	----	----	2085 846
23-26-55	MOULDING, Center Pillar Cover Protector						
	Sp. 4D., Sp. 4D. Sub., w/Swivel Seats						
	Right	1	----	2161 070	2161 070	2161 070	----
	Left	1	----	2161 071	2161 071	2161 071	----
23-26-58	CAP, Center Pillar Finish						
	Sp. 4 D.						
	Right	1	----	----	----	----	*1902 392
	Left	1	----	----	----	----	*1902 393
23-26-59	COVER, Center Pillar Inner at Belt						
	4 D.						
	Right	1	----	----	----	----	2085 458
	Left	1	----	----	----	----	2085 459
23-26-62	CAP, Door Trim Panel Finish						
	Sp. 4 D., Sp. 4 D. Sub., PC3						
	Rear Door Rear, Right	1	----	----	----	1902 476	1830 498
	Left	1	----	----	----	1902 477	1830 499
23-26-63	CAP, Quarter Trim Panel Finish						
	Cl. Sed., P1-L, P2-L, P1-M, P2-M, Trim Code						
	349, Moulding End	4	1694 182	----	----	----	----
23-26-80	STAR, Front Door Trim Panel Metal,						
	Sp. Cl. Cp., 4 D., Sp. 4 D., S3	2	----	----	2085 919	----	----
23-26-87	MOULDING, Floor Tunnel Console Finish						
	C3-300						
	Right	1	----	----	----	2161 016	----
	Left	1	----	----	----	2161 017	----
	Rear	2	----	----	----	2161 018	----
	Rear Right	1	----	----	----	2161 014	----
	Left	1	----	----	----	2161 015	----
	Front Right	1	----	----	----	2161 012	----
	Left	1	----	----	----	2161 013	----
23-26-89	COVER, Floor Tunnel Console Finish						
	Moulding Joint, C3-300	2	----	----	----	2161 011	----
23-31-O PADS, LINERS, INSULATORS, SEALS, ANTI-SQUEAK							
23-31-6	ANTI-SQUEAK, Wheelhouse Support to Side						
	Rail Reinforcement Extension Brace,						
	Sp. Cl. Cp.	2	1242 974	1242 974	----	----	----
23-31-33	LINER, Dash	1	2089 893	2089 893	2089 893	2089 893	2085 865
23-31-36	FASTENER, Dash Liner						
	w/or w/o Heater and Air Conditioning	★	6008 109	6008 109	6008 109	6008 109	6008 109
23-31-53	SEAL, Quarter Outside Panel Strainer, Cv. Cp.	★	1242 974	----	----	----	----
23-31-119	PAD, Steering Column Finish to Floor						
	w/Power Strg., w/Std. Trans.	1	2080 939	2080 939	----	----	----
	D3, D4, S1, w/o Power Strg., w/Std. Trans.	1	2080 935	2080 935	2080 935	----	----
	C1, w/o Power Strg., w/Auto. Trans.	1	2080 936	2080 936	2080 936	2080 936	----

★ Indicates use as required.

□ Indicates parts not listed in any previous parts book.

Dec. 9, 1960 Supersedes April 20, 1960.

Page 23-72

Printed in U.S.A.
Prices and specifications subject to change without notice.

* Indicates change or addition.

CODE	REMARKS	PER CAR	PLYMOUTH	DODGE	DESOTO	CHRYSLER	IMPERIAL
23-31-0 PADS, LINERS, INSULATORS, SEALS, ANTI-SQUEAK - Cont'd							
23-31-119	PAD - Cont'd						
	C1, w/Power Strg., w/Auto. Trans.	1	2080 938	2080 938	2080 938	2080 938	----
	C2, C3	1	----	----	----	2080 937	2080 937
	w/Power Strg., w/Std. Trans., w/LINER	1	2161 723	2161 723	----	----	----
	S1, w/o Power Strg., w/Std. Trans.	1	2161 565	2161 565	2161 565	----	----
	S1, w/o Power Strg., w/Std. Trans., w/LINER	1	2161 724	2161 724	2161 724	----	----
23-31-124	SEAL, Steering Column to Floor	1	----	2080 764	2080 764	----	----
	D1, D2, S1, w/o Auto. Trans., w/o Power Strg.	1	----	----	----	----	----
	C1, w/Auto. Trans., w/o Power Strg., w/Strg. Gear Coupling	1	2080 766	2080 766	2080 766	2080 766	----
	D3, D4, w/Std. Trans., w/Power Strg.	1	2080 769	2080 769	----	----	----
	D3, D4, w/Auto. Trans., w/o Power Strg., w/o Strg. Gear Coupling	1	2080 765	2080 765	----	----	----
	w/o Auto. Trans., w/o Power Strg.	1	2080 763	2080 763	----	----	----
	C1, w/Auto. Trans., w/Power Strg.	1	2080 768	2080 768	2080 768	2080 768	----
	C2, C3, w/Auto. Trans., w/Power Strg.	1	----	----	----	2080 767	----
	All	1	----	----	----	----	1830 452
23-31-125	SILENCER, Steering Column Opening Cover	1	----	----	----	----	1767 102
23-31-128	SCREW and WASHER, Steering Column Seal to Floor	5	----	----	----	----	6000 160
23-31-145	WEATHERSTRIP, Cowl to Hood	1	----	----	----	----	1751 182
23-31-150	SEAL, Rear Floor Pan Extension to Quarter Panel						
	Sp. Cl. Cp., 4 D., Sp. 4 D., Cv. Cp.	2	----	----	----	----	1752 016
23-31-205	SILENCER, Roof Panel						
	1/2" x 25 1/2" x 67"	★	1774 621	1774 621	1774 621	1774 621	----
	D3, D4, 1/8" x 25 1/2" x 67"	★	1774 625	1774 625	----	----	----
23-32-0 PANS, PLUGS AND BODY BUMPERS							
23-32-14	SCREW and WASHER, Floor Pan Sub., w/Tire Well Lock, Latch Striker	2	6000 160	6000 160	----	6000 160	----
23-32-15	PLUG or BUTTON, Floor Pan 1/2" Hole	★	*1810 273	----	----	----	2093 945
	1" Hole	★	2094 985	2094 985	2094 985	2094 985	----
	2 1/2" Hole	★	2094 244	2094 244	2094 244	2094 244	1869 582
	1 3/4" Hole	★	2094 595	2094 595	----	----	----
	7/8" Hole	★	2094 631	2094 631	2094 631	2094 631	----
	1/2" Hole	★	2094 984	2094 984	2094 984	2094 984	----
23-32-17	CROSSMEMBER, Front Floor Pan Rear CROSSMEMBER and REINFORCEMENT, Rear Floor Pan Rear, except Sub.	1	----	----	----	----	1861 264
23-32-34	SPACER, Fuel Tank to Floor Pan Reinforcement, except Sub.	2	*1960 180	*1960 180	*1960 180	*1960 180	----
23-32-36	COVER, Fuel Gauge Inspection Hole, Sub.	1	2123 639	2123 639	2123 639	2123 639	----
23-32-46	PANEL, Second Seat Back to Rear Floor Pan Cover, Sub.	1	1846 668	1846 668	----	1846 668	----
23-32-48	PAN, Rear Floor, except Sub.	1	1878 636	1878 636	----	1878 636	----
	Sub., 2 Seater, Center, Front	1	1861 002	1861 002	1861 002	1861 002	----
	Sub., Spare Tire Compartment	1	1861 041	1861 041	----	1861 041	----
	4 D. Sub., Sp. 4 D. Sub., 3 Seater	1	1973 211	1973 211	----	1973 211	----
	All	1	1973 226	1973 226	----	----	----
	Sp. Cl. Cp., Cv. Cp., 4 D., Sp. 4 D., D1, D2	1	----	1883 347	----	----	1877 346
	4 D. Sub., Sp. 4 D. Sub., D2, C1, 122" W.B.	1	----	1973 110	----	1973 110	----
	2 D. Sub., 122" W.B.	1	1973 110	----	----	----	----
	Except Sub., D3, D4, 118" W/B Complete	1	*1882 734	1973 149	----	----	----
23-32-49	EXTENSION, Rear Floor Pan Side						
	Sub.						
	Right	1	1960 166	----	----	----	----
	Left	1	1960 167	----	----	----	----
	D3, D4, except Sub.	Right	1861 010	1961 506	----	----	1877 762
		Left	1861 011	1961 507	----	----	1877 763
	Sp. 4 D. Sub.	Right	1	----	----	1960 080	----
		Left	1	----	----	1960 081	----

★ Indicates use as required.

⊠ Indicates parts not listed in any previous parts book.

* Indicates change or addition.

CODE	REMARKS	PER CAR	PLYMOUTH	DODGE	DESOTO	CHRYSLER	IMPERIAL
23-32-0 PANS, PLUGS AND BODY BUMPERS-Cont'd							
23-32-49	EXTENSION - Cont'd Cl.Sed., Sp.Cl.Cp., Cv.Cp., 4 D., Sp. 4 D., D1, D2						
	Right	1	----	1861 048	1861 048	1861 048	----
	Left	1	----	1861 049	1861 049	1861 049	----
	PAN, Rear Floor Side, Sub.						
	Right	1	1877 830	1877 830	----	1877 830	----
	Left	1	1877 831	1877 831	----	1877 831	----
23-32-51	BUMPER, Rear Compartment Cover Support on Wheel House, Sub., 2 Seater	2	1380 060	1380 060	----	1380 060	----
	BUMPER, Tailgate Opening Sill Panel to Rear Floor Pan Cover						
	Sub., 2 Seater	2	1380 060	1380 060	----	1380 060	----
23-32-54	EXTENSION, Deck Opening Lower Panel to Floor Pan, except Sub.	Center	1	1954 279	----	----	----
23-32-56	COVER, Rear Floor Pan Tire Well Sub., 2 Seater, w/Prop ROD and HINGES	1	1878 889	1878 889	----	1878 889	----
	FILLER, Rear Floor Pan Extension, Sp.Cl. Cp., Cv.Cp., 4 D., Sp. 4 D.						
	Right	1	----	----	1878 586	1878 586	----
	Left	1	----	----	1878 587	1878 587	----
23-32-58	STRIKER, Rear Floor Pan Cover Lock Latch Sub., w/Tire Well Lock	1	1960 476	1960 476	----	1960 476	----
23-32-64	LATCH, Rear Floor Pan Cover Lock Sub., w/Tire Well Lock	1	1866 685	1866 685	----	1866 685	----
23-32-65	HINGE, Rear Floor Pan Compartment or Tire Well Cover						
	Sub., 2 Seater, Body Half	Right	1	1878 170	1878 170	1878 170	----
		Left	1	1878 171	1878 171	1878 171	----
	WASHER	4	128 051	128 051	----	128 051	----
	NUT	4	190 872	190 872	----	190 872	----
23-32-66	SPRING, Rear Floor Pan Cover Lock Latch Sub., w/Tire Well Lock	1	1866 682	1866 682	----	1866 682	----
23-32-67	SUPPORT, Rear Compartment Cover on Wheelhouse, Sub., 2 Seater	2	1878 014	1878 014	----	1878 014	----
	SCREW and WASHER	8	1244 818	1244 818	----	1244 818	----
23-32-68	PLUG, Door Access Hole 4D., Front Door, Upper Extension Bracket, Upper and Lower	4	----	----	----	----	1751 764
	Center Rear	2	----	----	----	----	1751 762
	Rear Door, Upper Extension Bracket	Lower	2	----	----	----	1751 764
	Center, Front and Rear	4	----	----	----	----	1751 762
	PLUG, Tailgate Lock Adjusting Access Hole Button Sub.	2	2094 129	2094 129	----	2094 129	----
23-32-73	PIN, Rear Floor Pan Cover Hinge Sub., 2 Seater	2	1960 627	1960 627	----	1960 627	----
23-32-75	BRACKET, Rear Floor Pan Cover Lock Latch Sub., w/Tire Well Lock	1	1866 683	1866 683	----	1866 683	----
23-32-77	BOLT, Rear Floor Pan Cover Lock Latch Bracket						
	Sub., w/Tire Well Lock	2	1883 654	1883 654	----	1883 654	----
	NUT	2	151 497	151 497	----	151 497	----
23-32-79	BRACKET, Rear Floor Pan Cover Prop Rod Pivot, Sub., 2 Seater	1	1432 929	1432 929	----	1432 929	----
	Sub., 2 Seater, w/RETAINER	1	----	1960 689	----	----	----
23-32-80	HANDLE, Rear Floor Pan Cover Lift Sub., 2 Seater,	Prime	1	1775 891	1775 891	----	----
	4 D.Sub., Sp. 4D.Sub., 2 Seater, P1-M, P2-M, P1-H, P2-H, D2-H	Chrome	1	1833 596	1833 596	1833 596	----
	SCREW	2	155 113	155 113	----	155 113	----
23-32-82	ESCUTCHEON, Rear Floor Pan Cover Lift Handle						
	2D. Sub., 4D. Sub., P1-L, P2-L, D1-L, D3-L, D4-L, 2 Seater, Prime	1	1775 814	1775 814	----	1775 814	----
	4D.Sub., Sp. 4 D.Sub., 2 Seater, P1-M, P2-M, P1-H, P2-H, D2-H, D3-M, D4-M, Chrome	1	1833 597	1833 597	----	1833 597	----
	L/WASHER	2	138 530	138 530	----	138 530	----
	NUT	2	120 622	120 622	----	120 622	----
	SCREW	2	156 771	156 771	----	156 771	----

★ Indicates use as required.

☐ Indicates parts not listed in any previous parts book.

Dec. 9, 1960 Supersedes April 20, 1960.

Printed in U.S.A.

Prices and specifications subject to change without notice.

CODE	REMARKS	PER CAR	PLYMOUTH	DODGE	DESOTO	CHRYSLER	IMPERIAL
23-33-O INSTRUMENT PANEL							
23-33-10	BRACE, Instrument Panel to Pedal Bracket	1	----	----	----	1901 802	----
	BRACE, Instrument Panel Lower Reinforcement to Windshield Frame	1	2080 679	2080 899	2080 899	2080 899	----
	BRACE, Instrument Panel to Windshield Wiper Mounting Bracket	1	----	----	----	2080 649	----
	BRACE, Instrument Panel to Windshield Wiper Motor Mounting Bracket	1	----	----	----	----	2161 633
23-33-12	COVER, Instrument Panel Radio Opening	1	2080 965	1901 789	----	2080 008	1901 811
	NUT	2	----	----	----	120 622	----
	w/BEZEL, w/Name DeSoto	1	----	----	2080 993	----	----
	Knob Hole	2	----	----	----	----	2080 058
	NUT	2	----	----	----	----	151 497
23-33-20	COVER, Instrument Panel Clock Opening	1	1971 193	2080 889	*2080 889	2161 721	----
23-33-26	BEZEL, Instrument Panel Fresh Air Door Control, w/o Heater and Air Conditioner	1	*1902 154	1839 737	1839 737	----	----
	NOTE: w/HEATER see Part Type Code 1-48-70						
23-33-37	CUP WASHER, Instrument Panel Radio Speaker Mounting	4	----	1902 173	1902 173	----	----
23-33-42	GRILLE, Instrument Panel Radio Speaker All, Paint as Required	1	2049 389	----	----	----	----
	w/o Air Conditioning	1	----	1839 727	1839 727	----	----
	Prime	1	----	----	----	1839 683	----
	GRILLE, Heater and Air Conditioning Air Outlet and Radio, D1, D2, D4, w/Air Conditioning	1	2096 070	2096 070	2096 070	----	----
	GRILLE, Instrument Panel Radio Speaker and Defroster Opening, w/Air Conditioning, Prime	1	----	----	----	----	2080 338
	w/o Air Conditioning, Prime	1	----	----	----	----	2080 014
23-33-52	HOUSING, Instrument Panel Clock	1	----	----	2080 888	----	----
23-33-53	BRACKET, Instrument Panel Clock Housing	1	----	2080 916	2080 916	----	----
23-33-56	FINISH PLATE, Instrument Panel Controls, w/o Radio	1	1901 779	----	----	----	----
	Controls, w/Radio	1	2080 992	----	----	----	----
	D1, D2, Controls	1	----	1839 733	2161 001	----	----
	Controls	1	----	----	----	1839 698	1902 272
		1	----	----	----	1839 699	1902 273
23-33-65	COVER, Instrument Panel Defroster Opening	★	2080 238	2080 238	2080 238	2080 238	----
23-33-84	FASTENER, Instrument Panel Moulding w/Trim Pad	★	6008 222	6008 222	6008 222	6008 222	----
	Horizontal Moulding	7	6008 189	6008 189	6008 189	----	----
	CLIP, Instrument Panel Trim Pad Moulding Attaching	5	----	6008 200	6008 200	----	----
	CLIP, Instrument Panel Bezel Attaching	2	----	----	----	----	6008 198
23-33-86	MOULDING, Instrument Panel						
	Horizontal	1	2080 559	----	----	----	----
	w/Trim Pad	1	----	2080 470	2080 470	----	----
	D3, D4	1	----	2080 863	----	----	----
	NUT	7	----	445 153	----	----	----
	Finish Plate	1	----	2080 202	*2080 202	----	----
	D1, D2, Finish Plate End	1	----	1902 310	1902 310	----	----
		1	----	1902 311	1902 311	----	----
	NUT	6	----	445 153	----	----	----
	Speedometer Hood	1	----	----	2080 893	----	----
	Controls Finish Plate	1	----	----	----	1839 694	----
		1	----	----	----	1839 695	----
	Instruments Hood Finish Plate and Moulding	1	----	----	----	1902 220	----
	Instrument Hood Trim Pad	1	----	----	----	2080 362	2080 362

★ Indicates use as required.

☐ Indicates parts not listed in any previous parts book.

* Indicates change or addition.

Printed in U.S.A.

Prices and specifications subject to change without notice.

CODE	REMARKS	PER CAR	PLYMOUTH	DODGE	DESOTO	CHRYSLER	IMPERIAL
23-33-O INSTRUMENT PANEL-Cont'd							
23-33-94	STUD, Instrument Panel Mounting Clock Housing	2	----	----	2161 050	----	----
	Radio Speaker Grille	4	----	----	6008 039	6008 039	6008 012
	Gear Selector and Left End Extension Attaching	1	----	----	----	----	6008 030
	Gear Selector to Instrument Housing Attaching	2	----	----	----	----	6008 030
23-33-96	NAME PLATE, Instrument Panel Imperial	1	----	----	----	----	1839 778
	LeBaron	1	----	----	----	----	1902 315
	Guard, Instrument Panel Ignition Key	1	----	2080 960	2080 960	----	----
	NUT	1	----	445 153	445 153	----	----
23-33-109	PANEL, Instrument Sp. Cl. Cp., Cv. Cp., C3-300	1	2080 242	1901 783	1901 783	1901 799	1901 807
	Extension, Instrument Panel	1	----	----	----	2161 040	----
	End Right	1	----	----	----	----	2080 940
	Left	1	----	----	----	----	2080 941
23-33-110	SCREW and WASHER Instrument Panel S1, Lower Reinforcement to Pillar	2	6008 017	6008 017	6008 017	----	----
	Pillar Bracket to Pillar	2	----	----	----	----	6008 245
23-33-111	NUT, Instrument Panel Radio Opening Cover Attaching	2	6006 034	----	----	----	----
	Radio Opening Cover Attaching	2	6006 034	----	----	----	----
	Gear Selector Housing to Gear Selecting Bracket	1	----	6013 082	6013 082	----	----
	Instrument Panel to Speedometer Hood	★	----	6013 114	----	----	----
	Instrument Panel Finish Plate to End Extension Attaching	★	----	----	----	----	6010 128
23-33-129	HOOD, Instrument Panel Instrument	1	----	1839 730	----	----	----
	Upper	1	----	----	----	1839 689	----
	Lower	1	----	----	----	1839 690	----
	HOOD, Instrument Panel Speedometer	1	----	----	2080 892	----	----
23-33-132	CAP, Instrument Panel to Steering Column to Cluster	1	----	----	----	1971 522	----
	COVER, Instrument Panel Steering Column Opening	1	----	----	----	1902 091	----
	FILLER, Instrument Panel Steering Column Opening	1	----	1902 399	1902 399	----	----
	Paint as Required, Black, w/Std. Trans.	1	2169 929	----	----	----	----
	FILLER, Instrument Panel Steering Column Opening, S1, w/Std. Trans. Prime	1	2080 279	2080 279	2080 279	----	----
	BEZEL, Instrument Panel Instrument Cluster Lower Switch Mounting	1	----	----	----	1971 519	----
23-33-135	FINISH PLATE, Instrument Panel P1-M, P2-M, P1-H, P2-H, End	Right	1	1901 876	----	2161 000	----
	Left	1	----	----	2161 001	----	----
	D1, D2, w/Control Openings	Right	1	----	1839 732	----	----
	Left	1	----	1839 733	----	----	----
	Radio Control Opening, w/STUDS	Right	1	----	----	----	1902 272
	Left	1	----	----	----	----	1902 273
23-33-147	COVER, Instrument Panel End Extension	2	----	----	----	----	2080 942
23-33-153	COVER, Instrument Panel Cigar Lighter Hole	1	2080 048	----	----	----	----
23-33-213	BRACKET, Instrument Panel Gear Selector Mounting	1	----	1839 736	1839 736	1839 700	1839 765
	BRACKET, Instrument Panel Gear Selector and Heater Control Support	2	1901 859	----	----	----	----
	SUPPORT, Instrument Panel Gear Selector w/Auto. Trans.	1	1839 715	----	----	----	----
	NUT	★	120 614	----	----	----	----
	GROMMET	4	2161 522	----	----	----	----
23-33-216	COVER, Instrument Panel Map Lamp Opening	1	----	2080 152	2080 152	----	----
23-33-217	HOUSING, Instrument Panel Gear Selector	1	----	----	----	1839 691	----
23-33-220	BEZEL, Instrument Panel Gear Selector S1	1	*1901 564	1902 329	1902 329	----	----
	w/Std. Trans.	1	*1901 581	1902 330	1902 330	----	----
	w/PowerFlite Trans.	1	1901 580	1902 331	1902 331	----	1839 769
	w/Auto. 3 Speed Trans.	1	----	----	----	----	----
	BEZEL, Instrument Panel Gear Selector and Heater Control, w/Std. Trans. and w/o Heater	1	----	----	1902 361	----	----
	w/Auto. 3 Speed Trans. and w/o Heater	1	----	----	1902 357	----	----

★ Indicates use as required.

☐ Indicates parts not listed in any previous parts book.
Dec. 9, 1960 Supersedes April 20, 1960.

Printed in U.S.A.

Prices and specifications subject to change without notice.

CODE	REMARKS	PER CAR	PLYMOUTH	DODGE	DESOTO	CHRYSLER	IMPERIAL
23-33-O INSTRUMENT PANEL-Cont'd							
23-33-224	NUT, Instrument Panel Dummy Knob Adapter Mounting	2	----	----	----	1971 521	----
23-33-226	KNOB, Dummy Switch Control	2	----	----	----	1887 991	----
23-33-227	PAD, Instrument Panel Gear Selector Housing	1	1902 347	2080 457	2080 457	----	----
	Bezel	1	----	----	----	2080 388	----
23-33-240	GROMMET, Instrument Panel Gear Selector Support, D2, D3, D4, S1	4	2161 522	2161 522	2161 522	----	2080 694
23-34-O BODY PANELS							
23-34-16	PANEL, Tail Gate Opening Sill Sub.	1	1877 833	1877 833	----	1877 833	----
23-34-17	REINFORCEMENT, Tail Gate Opening Sill Panel, Sub.	1	1877 834	1877 834	----	1877 834	----
23-34-26	PANEL, Wheelhouse to Rear Pillar Sub.	Right	1 1960 090	1960 090	----	1960 090	----
		Left	1 1960 091	1960 091	----	1960 091	----
23-34-27	PANEL, Wheelhouse 4D., Sp. 4D., Sp. Cl. Cp., Cl. Sed., D3, D4, Right	1	2084 520	2084 520	----	----	----
		Left	1 2084 521	2084 521	----	----	----
	4 D., Sp. 4 D., Sp. Cl. Cp., D1, D2	Right	1 ----	2084 524	2084 524	2084 524	2084 526
		Left	1 ----	2084 525	2084 525	2084 525	2084 527
	Cv. Cp., D4	Right	1 2084 518	2084 518	----	----	----
		Left	1 2084 519	2084 519	----	----	----
	Cv. Cp., D2	Right	1 ----	2084 522	2084 522	2084 522	2084 528
		Left	1 ----	2084 523	2084 523	2084 523	2084 529
	Sub.	Right	1 2084 516	2084 516	----	2084 516	----
		Left	1 2084 517	2084 517	----	2084 517	----
23-34-32	BAFFLE or SEAL, Wheelhouse to Quarter Panel Dust 2 D. Sub.	BAFFLE Right	1 2093 838	----	----	----	----
		BAFFLE Left	1 2093 839	----	----	----	----
		SEAL	2 2188 958	----	----	----	----
23-34-80	PANEL, Cowl Side except Cv. Cp.	Right	1 1909 324	1909 324	1909 324	1909 324	----
		Left	1 1909 325	1909 325	1909 325	1909 325	----
	Cv. Cp.	Right	1 1952 946	1952 946	----	1952 946	2084 760
		Left	1 1952 947	1952 947	----	1952 947	2084 761
	4 D.	Right	1 ----	----	----	----	2084 762
		Left	1 ----	----	----	----	2084 763
	Sp. Cl. Cp., Sp. 4 D.	Right	1 ----	----	----	----	2084 758
		Left	1 ----	----	----	----	2084 759
	PANEL, Cowl Top and Dash, with Windshield Lower Frame w/o Air Conditioning FRAME and PANEL, Windshield and Cowl Top Complete	1	1909 312	1909 312	1909 312	1909 312	----
	4 D., Sp. 4D., Sp. Cl. Cp.	1	----	----	----	----	2084 538
	Cv. Cp.	1	----	----	----	----	2084 539
23-34-85	COVER PACKAGE, Cowl Upper Panel to Front Pillar Joint	Right	1 ----	----	----	----	2196 479
		Left	1 ----	----	----	----	2196 480
	SCREW	2	----	----	----	----	9413 268
23-34-100	FILLER, Cowl Side to Door at Belt	Right	1 ----	----	----	----	2188 416
		Left	1 ----	----	----	----	2188 417
23-34-110	PANEL, Dash	1	----	----	----	----	2084 534
23-34-116	COVER, Dash Panel Air Duct w/o Heater or Heater and Air Conditioning w/Heater	1	1750 445	1750 445	1750 445	1750 445	1750 445
	BOLT	12	180 018	180 018	180 018	180 018	180 018
	Rubber, Drain Hole	2	1810 565	1810 565	1810 565	1810 565	1810 565
	Air Duct	1	----	----	----	----	1861 425
23-34-117	NUT, Dash Panel Body Front Hold-Down Brace Reinforcement, C1	2	----	152 263	152 263	152 263	----

★ Indicates use as required.

☐ Indicates parts not listed in any previous parts book.

* Indicates change or addition.

1960 PASSENGER CAR PARTS CATALOG

BODY

CODE	REMARKS	PER CAR	PLYMOUTH	DODGE	DESOTO	CHRYSLER	IMPERIAL
23-34-O BODY PANELS-Cont'd							
23-34-120	PANEL, Door Outside Repair 4 D.						
	Front Right	1	1954 736	1954 736	1954 740	1954 740	1877 388
	Left	1	1954 737	1954 737	1954 741	1954 741	1877 389
	4 D. Sub.						
	Front Right	1	1954 736	1954 736	-----	-----	-----
	Left	1	1954 737	1954 737	-----	-----	-----
	Sp. 4D., Sp. 4 D. Sub.						
	Front Right	1	2165 236	2165 236	-----	-----	-----
	Left	1	2165 237	2165 237	-----	-----	-----
	Sp. 4 D., Sp. 4 D. Sub.						
	Front Right	1	-----	-----	2165 240	2165 240	1877 284
	Left	1	-----	-----	2165 241	2165 241	1877 285
	Sp. Cl. Cp., Cv. Cp.						
	Right	1	1867 682	1867 682	1869 662	1869 662	1877 288
	Left	1	1867 683	1867 683	1869 663	1869 663	1877 289
	Cl. Sed., 2 D. Sub.						
	Right	1	1954 738	1954 738	-----	-----	-----
	Left	1	1954 739	1954 739	-----	-----	-----
	Sp. 4 D., D1, D2						
	Rear Right	1	1867 870	1869 664	-----	-----	1877 286
	Left	1	1867 871	1869 665	-----	-----	1877 287
	Sp. 4 D., D3, D4						
	Rear Right	1	-----	1963 002	-----	-----	-----
	Left	1	-----	1963 003	-----	-----	-----
	4 D., D1, D2						
	Rear Right	1	1954 742	1869 672	1869 674	1869 674	1877 376
	Left	1	1954 743	1869 673	1869 675	1869 675	1877 377
	4 D., D3, D4						
	Rear Right	1	-----	1964 502	-----	-----	-----
	Left	1	-----	1964 503	-----	-----	-----
	4 D. Sub.						
	Rear Right	1	1954 744	1954 744	-----	-----	-----
	Left	1	1954 745	1954 745	-----	-----	-----
	Sp. 4 D. Sub.						
	Rear Right	1	-----	1869 670	-----	-----	-----
	Left	1	-----	1869 671	-----	-----	-----
	Sp. 4D., Sp. 4D. Sub.						
	Rear Right	1	-----	-----	1869 678	1869 678	-----
	Left	1	-----	-----	1869 679	1869 679	-----
23-34-122	BRACE and C/NUT, Dash Panel No. 1 and No. 1A Body Hold-Down Bolt						
	Right	1	-----	-----	-----	-----	E2189 128
	Left	1	-----	-----	-----	-----	E2189 129
23-34-126	REINFORCEMENT, Dash Panel No. 1 and No. 1A Body Hold-Down Bolt Brace						
	Right	1	-----	-----	-----	-----	*1861 248
	Left	1	-----	-----	-----	-----	*1861 249
23-34-136	COVER, Front Door Inside Panel Access Hole						
	Upper Front	2	-----	-----	-----	-----	1751 033
23-34-166	PANEL, Deck Opening Upper 4 D., Sp. 4 D., Cl. Sed.						
	4 D., Sp. 4 D., D1, D2	1	1909 314	1909 314	-----	-----	-----
	Sp. Cl. Cp., D3, D4	1	-----	1909 316	1963 213	1963 213	1961 444
	Sp. Cl. Cp., D3, D4	1	1909 313	1909 313	-----	-----	-----
	Sp. Cl. Cp., D1, D2	1	-----	1909 315	-----	-----	1961 442
	Sp. Cl. Cp. w/Deck Lid Tire COVER	1	-----	-----	1963 214	1963 214	-----
	Cv. Cp.	1	-----	-----	-----	2196 635	1961 443
	Cv. Cp., D2	1	-----	*1869 636	-----	-----	-----
	Cv. Cp., D3, D4	1	*1869 633	*1869 633	-----	-----	-----
23-34-167	PANEL, Deck Opening Lower, except Sub.	1	2084 514	2084 513	1973 152	1973 153	*1877 282
23-34-174	TUBE, Deck Opening Lower Panel Drain Sp. Cl. Cp., Cv. Cp., 4D., Sp. 4 D.	2	-----	-----	2188 499	2188 499	-----
23-34-176	EXTENSION, Quarter Outside Rear Panel 4D., Sp. 4D., Sp. Cl. Cp., Cv. Cp., Cl. Sed., D3, D4						
	Right	1	-----	1963 024	-----	-----	-----
	Left	1	-----	1963 025	-----	-----	-----
	Cl. Sed., 4 D., Sp. 4 D., Sp. Cl. Cp., Cv. Cp., D1, D2						
	Upper, Right	1	-----	1883 782	-----	-----	-----
	Left	1	-----	1883 783	-----	-----	-----
	Except Sub.						
	Lower, Right	1	-----	1952 762	-----	-----	-----
	Left	1	-----	1952 763	-----	-----	-----
	EXTENSION, Deck Opening Lower Panel to Floor Pan End, except Sub.						
	Right	1	1954 280	-----	-----	-----	-----
	Left	1	1954 281	-----	-----	-----	-----
	EXTENSION, Deck Opening Lower						
	Right	1	-----	-----	-----	-----	1877 350
	Left	1	-----	-----	-----	-----	1877 351
23-34-177	REINFORCEMENT, Quarter Panel Deck Opening Side Flange, Cl. Sed., Sp. Cl. Cp., Cv. Cp., 4 D., Sp. 4 D.						
	Right	1	1909 416	1883 848	-----	-----	-----
	Left	1	1909 417	1883 849	-----	-----	-----

★ Indicates use as required.

⊘ Indicates parts not listed in any previous parts book.
Dec. 9, 1960 Supersedes April 20, 1960.

Printed in U.S.A.
Prices and specifications subject to change without notice.

* Indicates change or addition.

CODE	REMARKS	PER CAR	PLYMOUTH	DODGE	DESOTO	CHRYSLER	IMPERIAL
23-34-O BODY PANELS-Cont'd							
23-34-178	PLUG, Front Floor Pan Drain Hole	2	1810 273	1810 273	1810 273	1810 273	1810 273
	PLUG, Deck Opening Lower Panel Side						
	Extension Bumper Access Hole	2	----	----	----	----	1810 076
23-34-179	REINFORCEMENT or SUPPORT, Deck						
	Opening Panel						
	Cv. Cp., D3, D4	Upper	*1882 391	*1882 391	----	*1882 286	----
	Cv. Cp., D2	Upper	----	*1882 393	----	----	----
	All	Lower	----	----	----	----	E2093 925
	All, except Sub., Support	Lower Right	----	E1954 098	----	----	----
		Left	----	E1954 099	----	----	----
23-34-182	PANEL, Deck Opening Lower Panel Fuel	1	----	----	*1878 576	*1878 576	----
	Tank Filler Tube Opening, except Sub.						
23-34-184	LETTER or NAME PLATE PACKAGE, Deck	1	----	----	----	2196 659	----
	Opening Lower Panel, except Sub., Chrysler	4	----	----	----	6000 490	----
	NUT and SEAL	"T"	2	----	----	----	2196 486
	NUT and SEAL	"M"	1	----	----	----	6000 490
	NUT and SEAL	"P"	2	----	----	----	2196 487
	NUT and SEAL	"E"	1	----	----	----	6000 490
	NUT and SEAL	"R"	2	----	----	----	2196 488
	CLIP	"A"	1	----	----	----	6000 490
	CLIP	"L"	1	----	----	----	2196 489
	NUT and SEAL	"L"	1	----	----	----	6006 468
	NUT and SEAL	"L"	2	----	----	----	2196 490
	NUT and SEAL	"L"	1	----	----	----	6006 468
	NUT and SEAL	"L"	2	----	----	----	2196 491
	NUT and SEAL	"L"	1	----	----	----	6000 490
	NUT and SEAL	"L"	2	----	----	----	2196 492
	NUT and SEAL	"L"	2	----	----	----	6000 490
23-34-187	SEAL, Deck Opening Lower Panel to Rear	1	1954 573	----	----	----	----
	Bumper except Sub.						
23-34-225	COVER, Quarter Inside Panel Access Hole,	2	----	----	----	----	1691 107
	Sp.Cl.Cp., Cv.Cp.						
23-34-227	GUARD, Quarter Panel Rear Lower Dust						
	Sub., Rubber	Right	1 2093 666	2093 666	----	2093 666	----
		Left	1 2093 667	2093 667	----	2093 667	----
23-34-228	RETAINER, Quarter Panel Lower Dust Guard	2	2093 478	----	----	2093 478	----
	Sub.						
23-34-230	STRAINER and Clinch NUT, Quarter Panel	2	1964 514	----	----	----	----
	Cv.Cp.						
23-34-231	BRACKET, Quarter Outside Panel Strainer						
	to Quarter Lower Pillar, Cv.Cp.	Right	1 1964 310	----	----	----	----
		Left	1 1964 311	----	----	----	----
23-34-233	PANEL, Quarter Outside Rear, Inner						
	except Sub.	Right	1 1882 080	----	----	----	----
		Left	1 1882 081	----	----	----	----
	4 D., Sp. 4 D., D1, D2	Right	1 ----	1882 036	----	----	----
		Left	1 ----	1882 037	----	----	----
	4D., Sp. 4 D., D3, D4	Right	1 ----	1963 012	----	----	1877 272
		Left	1 ----	1963 013	----	----	1877 273
	Sp.Cl.Cp., D1, D2	Right	1 ----	1882 034	----	----	----
		Left	1 ----	1882 035	----	----	----
	Sp.Cl.Cp., D3, D4	Right	1 ----	1963 028	----	----	1877 308
		Left	1 ----	1963 029	----	----	1877 309
	Cv.Cp., D2	Right	1 ----	1882 040	----	----	----
		Left	1 ----	1882 041	----	----	----
	Cv.Cp., D3, D4	Right	1 ----	1963 032	----	----	1877 340
		Left	1 ----	1963 033	----	----	1877 341
	Cl.Sed., D3,D4	Right	1 ----	1963 022	----	----	----
		Left	1 ----	1963 023	----	----	----
23-34-234	PANEL, Quarter Inside						
	Sp.Cl.Cp., D3, D4	Right	1 1963 738	1963 738	----	----	----
		Left	1 1963 739	1963 739	----	----	----
	Sp.Cl.Cp., D1, D2	Right	1 ----	1963 740	1963 740	1963 740	1751 000
		Left	1 ----	1963 741	1963 741	1963 741	1751 001

★ Indicates use as required.

⊠ Indicates parts not listed in any previous parts book.

* Indicates change or addition.

1960 PASSENGER CAR PARTS CATALOG

BODY

CODE	REMARKS	PER CAR	PLYMOUTH	DODGE	DESOTO	CHRYSLER	IMPERIAL
23-34-O BODY PANELS-Cont'd							
23-34-234	PANEL - Cont'd						
	Cv. Cp., D2	Right	1 1964 184	1964 186	----	1964 182	1751 002
		Left	1 1964 185	1964 187	----	1964 183	1751 003
	Cv. Cp., D3, D4	Right	1 ----	1964 184	----	----	----
		Left	1 ----	1964 185	----	----	----
	Cl. Sed., 2 D. Sub.	Right	1 1963 736	1963 736	----	----	----
		Left	1 1963 737	1963 737	----	----	----
23-34-235	PANEL and LOCK PILLAR, Quarter Outside						
	4 D., Sp. 4 D., D3, D4	Right	1 2084 493	2084 542	----	----	----
		Left	1 2084 494	2084 543	----	----	----
	4 D., Sp. 4 D., D1, D2	Right	1 ----	2084 507	1952 328	1952 328	1877 590
		Left	1 ----	2084 508	2165 867	2165 867	1877 591
	Sp. Cl. Cp., D1, D2	Right	1 ----	2084 505	1964 840	1964 840	1877 592
		Left	1 ----	2084 506	1964 841	1964 841	1877 593
	Sp. Cl. Cp., D3, D4	Right	1 2084 495	2084 511	----	----	----
		Left	1 2084 496	2084 512	----	----	----
	Cv. Cp., D4	Right	1 2084 497	2084 548	1964 842	1964 842	1877 594
		Left	1 2084 498	2084 549	1964 843	1964 843	1877 595
	Cl. Sed.	Right	1 2084 503	2084 509	----	----	----
		Left	1 2084 504	2084 510	----	----	----
	Cv. Cp., D2	Right	1 ----	2084 540	----	----	----
		Left	1 ----	2084 541	----	----	----
	2 D. Sub.	Right	1 2084 501	----	----	----	----
		Left	1 2084 502	----	----	----	----
	4 D. Sub., Sp. 4 D. Sub.	Right	1 2084 499	2196 114	----	2196 116	----
		Left	1 2084 500	2196 115	----	2196 117	----
	PANEL, Quarter Outside Repair,						
	Sp. Cl. Cp., D3, D4	Right	1 1869 644	1963 026	1861 074	1861 074	2093 368
		Left	1 1869 645	1963 027	1861 075	1861 075	2093 369
	2 D. Sub.	Right	1 1861 064	----	----	----	----
		Left	1 1861 065	----	----	----	----
	4 D., Sp. 4 D., D1, D2	Right	1 1869 640	1869 650	1861 078	1861 078	2093 372
		Left	1 1869 641	1869 651	1861 079	1861 079	2093 373
	Sp. Cl. Cp., Cv. Cp., D1, D2	Right	1 ----	1869 654	----	----	----
		Left	1 ----	1869 655	----	----	----
	Cl. Sed., D3, D4	Right	1 1869 642	1963 008	----	----	----
		Left	1 1869 643	1963 009	----	----	----
	Cv. Cp., D3, D4	Right	1 1869 646	1963 030	----	1954 370	2093 370
		Left	1 1869 647	1963 031	----	1954 371	2093 371
	4 D. Sub., Sp. 4 D. Sub.	Right	1 1861 066	1861 068	----	1861 082	----
		Left	1 1861 067	1861 069	----	1861 083	----
	4 D., Sp. 4 D., D3, D4	Right	1 ----	1963 010	----	----	----
		Left	1 ----	1963 011	----	----	----
23-34-236	EXTENSION, Quarter Inside, 2 D. Sub.	Right	1 1950 276	----	----	----	----
		Left	1 1950 277	----	----	----	----
	Sp. Cl. Cp., Cv. Cp., 4 D., Sp. 4 D., D1, D2	Upper Right	1 ----	1883 782	----	----	----
		Left	1 ----	1883 783	----	----	----
	Cv. Cp.	Right	1 ----	----	----	----	1750 188
		Left	1 ----	----	----	----	1750 189
	Sp. Cl. Cp.	Right	1 ----	----	----	----	1692 142
		Left	1 ----	----	----	----	1692 143
	Sp. Cl. Cp., Cv. Cp., w/Clinch NUT	Right	1 ----	----	----	----	1810 204
		Left	1 ----	----	----	----	1810 205
23-34-238	NAME PLATE, Quarter Outside						
	Sub., PKG.	Custom	2 2196 126	----	----	----	----
	CLIP		4 6000 020	----	----	----	----
	Sub., PKG.	Sport	2 2196 127	----	----	----	----
	CLIP		4 6000 020	----	----	----	----
	PKG.	Seneca	2 ----	2196 804	----	----	----
	PALNUT		4 ----	6000 616	----	----	----
	PKG.	Pioneer	2 ----	2196 803	----	----	----
	PALNUT		4 ----	6000 616	----	----	----
	PKG.	Phoenix	2 ----	2196 802	----	----	----
	PALNUT		4 ----	6000 616	----	----	----
		Gold Finish Adventurer	2 ----	----	2196 840	----	----
		Chrome Finish Adventurer	2 ----	----	2196 876	----	----
	NUT		4 ----	----	152 259	----	----

★ Indicates use as required.

⊠ Indicates parts not listed in any previous parts book.

Dec. 9, 1960 Supersedes April 20, 1960.

Prices and specifications subject to change without notice.

* Indicates change or addition.

Printed in U.S.A.

CODE	REMARKS	PER CAR	PLYMOUTH	DODGE	DESOTO	CHRYSLER	IMPERIAL
23-34-0 BODY PANELS - Cont'd							
23-34-240	DEFLECTOR PACKAGE, Quarter Panel Stone Sub.						
	Right	1	2196 184	----	----	----	----
	Left	1	2196 185	----	----	----	----
	SCREW	2	125 978	----	----	----	----
	NUT	4	6000 028	----	----	----	----
	Except Sub., DEFLECTOR						
	Right	1	2084 562	----	----	----	----
	Left	1	2084 563	----	----	----	----
	NUT and SEAL	4	6000 028	----	----	----	----
	D1, D2, DEFLECTOR						
	Right	1	----	2196 400	----	----	----
	Left	1	----	2196 401	----	----	----
	NUT and SEAL	4	----	6000 021	----	----	----
	SCREW	2	----	9413 433	----	----	----
	D3, D4, except Sub., DEFLECTOR						
	Right	1	----	2196 294	----	----	----
	Left	1	----	2196 295	----	----	----
	SCREW	2	----	274 660	----	----	----
	Sub., D3, D4, DEFLECTOR						
	Right	1	----	2196 400	----	----	----
	Left	1	----	2196 401	----	----	----
	All, DEFLECTOR						
	Right	1	----	----	*2196 528	*2196 528	----
	Left	1	----	----	2196 529	2196 529	----
	SCREW	6	----	----	125 978	125 978	----
	All, DEFLECTOR						
	Right	1	----	----	----	----	*2196 818
	Left	1	----	----	----	----	2196 819
	SCREW	4	----	----	----	----	9414 080
23-34-242	EXTENSION, Rear Quarter Outside Panel Sub., Rear Outer						
	Right	1	1861 090	1960 648	----	----	----
	Left	1	1861 091	1960 649	----	----	----
	4 D. Sub., Rear Upper						
	Right	1	----	1878 294	----	----	----
	Left	1	----	1878 295	----	----	----
	Sub., Rear Lower						
	Right	1	----	1861 094	----	----	----
	Left	1	----	1861 095	----	----	----
	Sp. 4 D. Sub.						
	Right	1	----	----	----	1861 096	----
	Left	1	----	----	----	1861 097	----
23-34-245	RETAINER and STUD, Quarter Panel Outside Stone Deflector, except Sub., D3, D4	2	----	6000 779	----	----	----
23-34-249	REINFORCEMENT, Quarter Inside Panel to Wheelhouse						
	Sp. Cl. Cp.						
	Right	1	----	----	----	----	1810 056
	Left	1	----	----	----	----	1810 057
23-34-253	DOOR, Fuel Tank Filler	1	----	----	----	----	1877 283
23-34-255	SPRING, Fuel Tank Filler Door	1	----	----	----	----	1877 486
23-34-258	EXTENSION, Quarter Panel Tail Lamp Opening Reinforcement, Upper, Sp. Cl. Cp., Cv. Cp., 4 D., Sp. 4 D.						
	Right	1	----	----	1961 016	1961 016	----
	Left	1	----	----	1961 017	1961 017	----
23-34-270	BUMPER, Fuel Tank Filler Door	1	----	----	----	----	1882 429
23-34-275	BUMPER, Quarter Outside Panel Jack, except Sub.						
	Right	1	----	1964 650	----	----	----
	Left	1	----	1964 651	----	----	----
23-34-285	SUPPORT, Quarter Panel Outside Jack, Cl. Sed., Sp. Cl. Cp., Cv. Cp., 4 D., Sp. 4 D.						
	Right	1	1963 436	----	----	----	----
	Left	1	1963 437	----	----	----	----
23-34-286	BRACKET, Quarter Panel Rear Bumper Support Bar Jacking, Sub.						
	Right	1	1961 022	1961 024	----	1961 024	----
	Left	1	1961 023	1961 025	----	1961 025	----
23-34-301	PANEL, Roof, 4 D., Cl. Sed.	1	1867 948	----	----	----	----
	Sp. Cl. Cp., w/High Window	1	1952 666	1952 666	*1861 118	*1861 118	----
	Sp. Cl. Cp., P1-M, P2-M, D1-L, D3-M, D4-M w/Low Window	1	1869 615	1869 615	----	----	----
	Cl. Sed., Sp. 4 D., 4 D., D3, D4 w/Low Window	1	----	1963 016	----	----	----
	Sub.	1	2093 196	2093 196	----	2093 202	----
	4D., Sp. 4D., D1, D2, S1, w/Low Window	1	----	*1867 873	*1867 873	*1867 873	----
	Sp. 4 D., D3, D4 w/High Window	1	----	1963 017	----	----	----
	Sp. 4 D., P1-H, P2-H, D1, D2 w/High Window	1	1952 698	1952 642	1952 642	1952 642	----

* Indicates use as required.

□ Indicates parts not listed in any previous parts book.

* Indicates change or addition.

Printed in U.S.A.

Prices and specifications subject to change without notice.

1960 PASSENGER CAR PARTS CATALOG

BODY

CODE	REMARKS	PER CAR	PLYMOUTH	DODGE	DESOTO	CHRYSLER	IMPERIAL
23-34-0 BODY PANELS-Cont'd							
23-34-301	PANEL - Cont'd 4 D., Sp. 4 D. Sp. Cl. Cp. 4D., Sp. 4D. Sp. Cl. Cp.	w/EXTENSIONS w/EXTENSIONS 1 1	1 1 1 1	----- ----- ----- -----	----- ----- ----- -----	----- ----- ----- -----	1973 250 1973 251 *1877 732 *1877 267
NOTE: When using 1973250 on Low Window for PY1-H also use one each of 1961511, 1961513 Reinforcements and one 1961512 Extension Panel.							
23-34-302	PANEL, Roof Rear Extension, 4D., Sp. 4D., PY1-H		1	-----	-----	-----	*1961 512
	EXTENSION, Roof Panel Side Sp. Cl. Cp., w/Low Window	Right Left	1 1	*1883 296 *1883 297	*1883 296 *1883 297	----- -----	----- -----
	Sp. Cl. Cp.	w/High Window, Right Left	1 1	1952 684 1952 685	1952 684 1952 685	----- -----	----- -----
	Sub.	Right Left	1 1	1861 222 1861 223	1861 222 1861 223	1960 092 1960 093	----- -----
	Sp. Cl. Cp.	Lower, Right Left	1 1	----- -----	----- -----	1878 444 1878 445	1878 444 1878 445
	4 D., Sp. 4 D.	Right Left	1 1	----- -----	----- -----	----- -----	1877 492 1877 493
	Sp. Cl. Cp.	Right	1	-----	-----	-----	1877 742
	Sp. Cl. Cp.	Left	1	-----	-----	-----	1877 743
23-34-304	REINFORCEMENT, Roof Rear Extension Panel, 4D., Sp. 4D., PY1-H,	Upper Lower	1 1	----- -----	----- -----	----- -----	*1961 511 1961 513
23-34-307	ORNAMENT, Roof 4 D., Sp. 4 D., D3-H, D4-H, Air Exhaust PKG.	Right Left	1 1	----- -----	2196 268 2196 269	----- -----	----- -----
	SCREW		4	-----	156 771	-----	-----
	WASHER		4	-----	1439 256	-----	-----
	NUT		4	-----	441 253	-----	-----
23-34-334	MEDALLION, Roof Panel Outside Side 4 D., Sp. 4 D., Y1-H, PKG.	w/BASE	2	-----	-----	-----	2196 813
	CLIP		2	-----	-----	-----	6006 030
	ORNAMENT, Quarter Panel Outside except Cv. Cp., Sp. Cl. Cp., Sp. 4 D., PKG.		2	2084 564	-----	-----	-----
	NUT		4	6006 264	-----	-----	-----
	CLIP		4	6000 752	-----	-----	-----
	Except Cv. Cp., 2 D. Sub., PKG.	Right Left	1 1	2084 735 2084 736	----- -----	----- -----	----- -----
	NUT		4	6006 264	-----	-----	-----
	CLIP		4	6000 752	-----	-----	-----
	Cl. Sed., Sp. Cl. Cp., Cv. Cp., D3, D4, PKG.		2	-----	2196 298	-----	-----
	NUT		2	-----	6006 264	-----	-----
	RING, Quarter Panel Medallion Base Inner, Sp. Cl. Cp., Cv. Cp., 4 D., Sp. 4 D., 4 D. Sub., P2-H	PKG.	2	2196 724	-----	-----	-----
	CLIP		3	6000 752	-----	-----	-----
	NUT		3	6006 264	-----	-----	-----
	MEDALLION, Quarter Outside Panel 4 D., Sp. 4 D., Sp. Cl. Cp., Cl. Sed., Cv. Cp., Sub., D1, D2, PKG.	Right Left	1 1	----- -----	*2196 404 2196 405	----- -----	----- -----
	CLIP		8	-----	6000 050	-----	-----
	Sp. Cl. Cp., Cv. Cp., C3-300	"300F"	2	-----	-----	1961 141	-----
	NUT		4	-----	-----	6006 215	-----
	PY1-M	PKG.	2	-----	-----	-----	2196 872
	CLIP		2	-----	-----	-----	6006 468
	LOUVER, Quarter Panel Outside C3, PKG.	Right Left	1 1	----- -----	----- -----	2196 599 2196 725	----- -----
	NUT and SEAL		36	-----	-----	152 259	-----
23-34-338	PLATE, Roof Panel Side Medallion 4 D., Sp. 4 D.		2	-----	-----	-----	1961 305

★ Indicates use as required.

Ⓛ Indicates parts not listed in any previous parts book.
Dec. 9, 1960 Supersedes April 20, 1960.Printed in U.S.A.
Prices and specifications subject to change without notice.

* Indicates change or addition.

CODE	REMARKS	PER CAR	PLYMOUTH	DODGE	DESOTO	CHRYSLER	IMPERIAL
23-34-O BODY PANELS - Cont'd							
23-34-339	ESCUTCHEON, Quarter Panel Outside Louver C3	Right Left	9 9	----	----	2093 360 2093 361	----
23-34-340	MEDALLION and BASE, Quarter Panel Sp. Cl. Cp., Cv. Cp., 4 D., Sp. 4 D., P1-H, P2-H, PKG.,	Right Left	1 1	E2275 037 E2275 038	----	----	----
	NUT		6	6006 264	----	----	----
	4D. Sub., P1-H, P2-H, Pkg.,	Right Left	1 1	E2275 039 E2275 040	----	----	----
	NUT		6	*6006 264	----	----	----
	Sp. Cl. Cp., Cv. Cp. C3-300, Base PKG.		2	----	----	2196 575	----
	NUT		4	----	----	6006 215	----
23-34-342	SPACER, Quarter Panel Outside Finish Top Rear Ornament Rear Screw		2	----	*1961 944	----	----
23-34-354	PANEL, Windshield Header Cv. Cp. w/REINFORCEMENT		1	1963 627	1963 627	1963 627	----
	PANEL, Reinforcement and Frame, Wind- shield Upper, except Cv. Cp.		1	1909 319	1909 319	1909 319	1909 319
23-36-O PILLAR							
23-36-5	PILLAR, Body Center 4 D.	Right Left	1 1	1909 892 1909 893	1909 892 1909 893	1909 892 1909 893	1973 132 1973 133
	Sp. 4 D., Sp. 4 D. Sub.	Right Left	1 1	1952 204 1952 205	1952 204 1952 205	1952 204 1952 205	1973 290 1973 291
	4 D. Sub.	Right Left	1 1	1909 892 1909 893	1909 892 1909 893	----	----
23-36-6	PANEL, Center Pillar Trim 4 D., 4 D. Sub.	Prime, Right Left	1 1	1882 884 1882 885	1882 884 1882 885	1882 884 1882 885	----
	4 D.	Upper, Right	1	----	----	----	1766 514
23-36-11	PLATE, Body Center Pillar Upper Hinge Reinforcement Back-Up D3, D4, 4 D. Taxi		1	1963 635	1963 635	----	----
23-36-18	PLUG, Body Pillar Hole w/o Auto. Door Switch		★	6013 105	6013 105	6013 105	6013 105
23-36-21	COVER, Pillar Hinge 4 D., Sp. 4 D.	Center	4	----	----	----	1751 793
23-36-22	PLATE, Body Center Pillar Front Tapping 4D., Sp. 4D., Sub.		2	E1952 214	E1952 214	E1952 214	E1952 214
23-36-53	PILLAR, Body Lock, Rear Sp. Cl. Cp.	Right Left	1 1	1869 772 1869 773	1869 772 1869 773	----	----
	Cv. Cp.	Right Left	1 1	1954 676 1954 677	1954 676 1954 677	----	----
	4 D., Sp. 4 D.	Right Left	1 1	1869 770 1869 771	----	----	----
	4 D., Sp. 4 D., D1, D2 w/Tapping PLATE,	Right Left	1 1	1964 418 1964 419	1973 044 1973 045	----	----
	4 D., Sp. 4 D., D3, D4 w/Tapping PLATE,	Right Left	1 1	----	1964 422 1964 423	1973 042 1973 043	1973 042 1973 043
	Sp. 4 D. Sub. w/Tapping PLATE,	Right Left	1 1	----	----	1973 042 1973 043	----
	4 D. Sub., Sp. 4 D. Sub. w/Tapping PLATE,	Right Left	1 1	1964 420 1964 421	1964 420 1964 421	----	----
	Cl. Sed., 2 D. Sub.	Upper Right Left	1 1 1	1884 700 1884 701	1884 700 1884 701	----	----
	Cl. Sed., 2 D. Sub., D3, D4	Lower, Right Left	1 1	1869 774 1869 775	1869 774 1869 775	----	----
	4 D. Sub., Sp. 4 D. Sub.	Right Left	1 1	1884 730 1884 731	1884 730 1884 731	----	----

★ Indicates use as required.

E Indicates parts not listed in any previous parts book.

* Indicates change or addition.

1960 PASSENGER CAR PARTS CATALOG

BODY

CODE	REMARKS	PER CAR	PLYMOUTH	DODGE	DESOTO	CHRYSLER	IMPERIAL
23-36-O PILLAR-Cont'd							
23-36-53	PILLAR - Cont'd						
	4 D., Sp. 4 D., D1, D2						
		Right	1	----	1884 730	----	----
		Left	1	----	1884 731	----	----
	Sp. Cl. Cp., w/REINFORCEMENT and Tapping PLATE						
		Right	1	----	----	1952 332	1952 332
		Left	-	----	----	1952 333	1952 333
	Cv. Cp., w/REINFORCEMENT and Tapping PLATE						
		Right	1	----	----	1954 814	----
		Left	1	----	----	1954 815	----
	Sp. Cl. Cp., Cv. Cp.						
		Right	1	----	----	----	1877 314
		Left	1	----	----	----	1877 315
	4 D., Sp. 4 D.						
		Right	1	----	----	----	1877 310
		Left	1	----	----	----	1877 311
	Sp. Cl. Cp., Cv. Cp., w/Tapping PLATE and COVERS						
		Right	1	----	----	----	1919 024
		Left	1	----	----	----	1919 025
23-36-66	REINFORCEMENT, Body Lock Pillar						
	4 D., P1-M, P2-M						
		Upper Right	1	1884 532	----	----	----
		Left	1	1884 533	----	----	----
	Cl. Sed., 2 D. Sub.						
		Upper, Right	1	1884 532	1884 532	----	----
		Left	1	1884 533	1884 533	----	----
	Sp. Cl. Cp., Cv. Cp.,						
		Rear Right	1	----	----	----	1690 440
		Left	1	----	----	----	1690 441
23-36-73	COVER, Lock Pillar Hole Edge Outer						
	Sp. Cl. Cp., Cv. Cp.,						
		Right	1	----	----	----	*1810 586
		Left	1	----	----	----	*1810 587
23-36-118	PILLAR, Body Rear						
	2 D. Sub., 4 D. Sub., Upper and Lower, w/Glass RUN and REINFORCEMENT						
		Right	1	1973 174	----	----	----
		Left	1	1973 175	----	----	----
	4 D. Sub., Sp. 4 D. Sub., Upper and Lower, w/Glass RUN and REINFORCEMENTS						
		Right	1	----	1973 174	----	1973 174
		Left	1	----	1973 175	----	1973 175
23-36-121	PANEL, Rear Upper Pillar to Side and Rear Roof Rail Joint Cover, Sub.						
		Right	1	1878 254	1878 254	----	1878 254
		Left	1	1878 255	1878 255	----	1878 255
23-36-123	HANDLE, Roof Panel Rear Pillar Outside Assist						
	4 D. Sub., Sp. 4 D. Sub., PKG.						
			2	2196 839	2196 839	----	2196 839
	NUT		8	6006 035	6006 035	----	6006 035
	BOLT		2	681 135	681 135	----	681 135
23-36-125	REINFORCEMENT, Rear Pillar to Wheelhouse Sub.						
		Right	1	1877 840	1877 840	----	1877 840
		Left	1	1877 841	1877 841	----	1877 841
23-36-128	BOLT, Roof Panel Rear Pillar Outside Assist Handle Attaching, Sub.						
			2	681 135	681 135	----	681 135
23-38-O FLOOR TUNNEL CONSOLE							
23-38-4	NUT, Floor Tunnel Console Access Door Attaching, C3-300						
			4	----	----	----	6022 003
23-38-5	PLATE, Floor Tunnel Console Finish C3-300						
		Front	1	----	----	----	2161 021
		Rear	1	----	----	----	2161 022
23-38-9	FILLER, Front Floor Tunnel Console to Instrument Panel, C3-300						
			1	----	----	----	2161 041
23-38-12	BASE, Floor Tunnel Console Arm Rest C3-300						
			2	----	----	----	B2241 393
23-38-14	HINGE, Floor Tunnel Console Arm Rest Lid C3-300						
			2	----	----	----	2161 038
23-38-16	REINFORCEMENT, Heel Pad Finish Plate Front, C3-300						
			2	----	----	----	2086 461
23-38-17	PLATE, Heel Pad Finish Front, C3-300						
			2	----	----	----	2086 460
23-38-19	BALL STUD, Floor Tunnel Console Arm Rest Lid Lock, C3-300						
			2	----	----	----	B2086 840

★ Indicates use as required.

□ Indicates parts not listed in any previous parts book.

Dec. 9, 1960 Supersedes April 20, 1960.

Printed in U.S.A.
Prices and specifications subject to change without notice.

* Indicates change or addition.

CODE	REMARKS	PER CAR	PLYMOUTH	DODGE	DESOTO	CHRYSLER	IMPERIAL	
23-38-O FLOOR TUNNEL CONSOLE - Cont'd								
23-38-20	BRACKET, Floor Tunnel Console Arm Rest Lid Stud Mounting, C3-300	2	----	----	----	----	E2086 839	
23-38-23	CABLE, Floor Console Arm Rest Lid Check C3-300	2	----	----	----	1909 425	----	
23-38-24	NUT, Floor Tunnel Console Arm Rest Lid Check Stamp Attaching C3-300	1	----	----	----	6022 151	----	
23-39-O WINDOW LIFT(MANUAL)								
23-39-2	SPRING, Door Manual Window Regulator except Sp. 4 D., Sp. 4 D. Sub., C1, C2 Sp.4 D., Sp.4 D.Sub., C1, C2	★ 2 2	1256 337 1256 337 1690 329	1256 337 1256 337 1690 329	1256 337 1256 337 1690 329	1256 337 1256 337 1690 329	1256 337 1256 337 ----	
23-39-5	REGULATOR or PLATE and LINK, Door Manual Window 4 D., Sp. 4 D., 4 D.Sub., Sp. 4 D.Sub., C1, C2	Front Right Left Rear Right Left Rear Right Left	1 1 1 1 1 1	1954 346 1954 347 1883 568 1883 569 1883 494 1883 495	1954 346 1954 347 1883 568 1883 569 1883 494 1883 495	1954 346 1954 347 1883 568 1883 569 1883 494 1883 495	1954 346 1954 347 1883 568 1883 569 1883 494 1883 495	2093 486 2093 487 2093 446 2093 447 2093 446 2093 447
23-39-6	SCREW and WASHER, Window Regulator Attaching	★	2165 287	2165 287	2165 287	2165 287	----	
23-39-8	SCREW, Window Regulator Arm Roller Stud RING, Manual Window Regulator Retaining, C1, C2	★ ★ ★	----	----	----	----	6006 172	
23-39-10	SPRING NUT, Window Regulator Link and Mounting Plate	★	E6022 287	E6022 287	E6022 287	E6022 287	----	
23-39-11	BOLT, Manual Window Regulator Arm and Link to Door Pivot	★	6000 211	6000 211	6000 211	6000 211	6006 239	
23-39-12	WASHER, Window Regulator Arm and Link Mounting Plate	★	6000 141	6000 141	6000 141	6000 141	----	
23-39-15	STOP, Rear Door Manual Window Regulator Pivot Arm, Sp.4 D.	2	----	----	----	----	1751 732	
23-39-17	BUSHING, Window Regulator Stud Door and Quarter	★	2166 511	2166 511	2166 511	2166 511	----	
23-39-18	ARM and LINK, Door Manual Window Regulator Pivot, 4 D., Sp.4 D., Sub., C1, C2 includes Mounting Plate, Front Right Left Front Right Left 4 D. Rear Right Left Sp. 4 D. Rear Right Left Sp.Cl.Cp., Cv.Cp., Cl.Sed., C1, C2 includes Mounting Plate, Right Left Right Left	1 1	1954 342 1954 343 ---- ---- ---- ---- ---- ---- ---- ---- 1954 342 1954 343 ---- ---- 1954 342 1954 343 ---- ---- 1954 342 1954 343 ---- ---- 1954 342 1954 343 ---- ---- 1954 342 1954 343 ---- ----	1954 342 1954 343 ---- ---- ---- ---- ---- ---- ---- ---- 1954 342 1954 343 ---- ---- 1954 342 1954 343 ---- ---- 1954 342 1954 343 ---- ----	1954 342 1954 343 ---- ---- ---- ---- ---- ---- ---- ---- 1954 342 1954 343 ---- ---- 1954 342 1954 343 ---- ----	1954 342 1954 343 ---- ---- ---- ---- ---- ---- ---- ---- 1954 342 1954 343 ---- ---- 1954 342 1954 343 ---- ----	---- ---- 1692 154 1692 155 2093 104 2093 105 1750 426 1750 427 ---- ---- 1750 466 1750 467	
23-39-33	STUD, Window Regulator Arm Glass Lower Channel Roller, All	8	----	----	----	----	1691 100	
23-39-34	REGULATOR, Quarter Manual Window Sp.Cl.Cp., C1, C2	Right Left	1 1	1884 492 1884 493	1884 492 1884 493	1884 492 1884 493	1884 492 1884 493	1651 416 1651 417
	Cv.Cp., C1, C2	Right Left	1 1	1884 494 1884 495	1884 494 1884 495	---- 1884 494	1884 494 1884 495	----
	Cl.Sed., 2 D.Sub.	Right Left	1 1	1884 490 1884 491	1884 490 1884 491	---- ----	---- ----	----

★ Indicates use as required.
 E Indicates parts not listed in any previous parts book.
 * Indicates change or addition.

1960 PASSENGER CAR PARTS CATALOG

CODE	REMARKS	PER CAR	PLYMOUTH	DODGE	DESOTO	CHRYSLER	IMPERIAL
23-39-0 WINDOW LIFT (MANUAL) - Cont'd							
23-39-36	SCREW and WASHER, Quarter Window Regulator Attaching, Sp.Cl.Cp., C1, C2	12	6000 704	6000 704	6000 704	6000 704	----
23-39-44	SPRING, Quarter Manual Window Regulator Sp.Cl.Cp., C1, C2	2	1690 329	1690 329	1690 329	1690 329	----
	Cv.Cp., Cl.Sed., 2 D.Sub., C1, C2	2	1256 337	1256 337	1256 337	1256 337	----
23-39-45	ROLLER, Window Regulator Arm Glass Lower Channel, All	8	----	----	----	----	1690 937
23-39-47	ARM and LINK, Quarter Manual Window Regulator, Sp.Cl.Cp.	Right 1 Left 1	----	----	----	----	1691 966 1691 967
23-39-53	RETAINER, Window Regulator Arm Stud C1, C2	★	6000 305	6000 305	6000 305	6000 305	6000 305
	RETAINER, Window Regulator Guide Arm Roller Pin						
	Sp. 4 D.	Rear 6	----	----	----	----	⊠195 733
23-40-0 ROOF RAIL AND LUGGAGE RACK							
23-40-82	SUPPORT, Rear Window Frame to Rear Headlining Bow						
	4 D., D3, D4, S3 w/High Window	1	1963 464	1963 464	1963 464	1963 464	----
	4 D., D1, D2, C1, C2 w/Low Window	1	----	1952 803	1952 803	1952 803	----
	Sp. 4 D., S3 w/High Window	1	----	----	1963 464	1963 464	----
	Sp. 4 D., S1, C1, C2 w/Low Window	1	----	----	1952 803	1952 803	----
23-40-85	RAIL, Roof Side, 4D., D1, D2	Right 1 Left 1	1959 560 1959 561	1959 570 1959 571	1959 570 1959 571	1959 570 1959 571	----
	4 D., D3, D4	Right 1 Left 1	----	1959 560 1959 561	----	----	----
	4 D.	Front Inner Right 1 Left 1 Front Outer Right 1 Left 1 Rear Outer Right 1 Left 1	----	----	----	----	1877 330 1877 331 1960 540 1960 541 1877 328 1877 329
	Sp. 4D., Sp. 4D. Sub., D1, D2	Right 1 Left 1	1959 562 1959 563	1959 572 1959 573	1959 572 1959 573	1959 572 1959 573	----
	Sp 4 D., D3, D4	Right 1 Left 1	----	1959 562 1959 563	----	----	----
	Sp. 4 D.	Front Inner Right 1 Left 1 Front Outer Right 1 Left 1 Rear Outer Right 1 Left 1	----	----	----	----	1961 064 1961 065 1960 540 1960 541 1877 328 1877 329
	Sp. Cl. Cp., except Fury and Polara	Right 1 Left 1	1959 566 1959 567	1959 566 1959 567	1961 618 1961 619	1961 618 1961 619	----
	Sp. Cl. Cp. w/High Window,	Right 1 Left 1	1959 564 1959 565	1959 564 1959 565	----	----	----
	Sp. Cl. Cp.	Front Inner Right 1 Left 1 Rear Inner Right 1 Left 1 Front Outer Right 1 Left 1 Rear Outer Right 1 Left 1	----	----	----	----	1877 768 1877 769 1877 450 1877 451 1960 542 1960 543 1961 584 1961 585
	Cl. Sed.	Right 1 Left 1	1959 568 1959 569	1959 568 1959 569	----	----	----
	4 D. Sub.	Right 1 Left 1	1959 578 1959 579	1959 578 1959 579	----	----	----
	2 D. Sub.	Right 1 Left 1	1959 576 1959 577	----	----	----	----
	RAIL, Roof Side Rear Sub.	Right 1 Left 1	1961 468 1961 469	1961 468 1961 469	----	1961 468 1961 469	----
	RAIL, Roof Rear, Sub.	1	⊠1960 636	⊠1960 636	----	⊠1960 636	----

★ Indicates use as required.

⊠ Indicates parts not listed in any previous parts book.
Dec. 9, 1960 Supersedes April 20, 1960.

Printed in U.S.A.
Prices and specifications subject to change without notice.
* Indicates change or addition.

CODE	REMARKS	PER CAR	PLYMOUTH	DODGE	DESOTO	CHRYSLER	IMPERIAL
23-40-O ROOF RAIL AND LUGGAGE RACK - Cont'd							
23-40-86	REINFORCEMENT, Roof Side Rail 4 D., Sp.4 D., D1, D2	Right 1	----	1869 556	1869 556	1869 556	----
		Left 1	----	1869 557	1869 557	1869 557	----
	4 D., Sp. 4 D., Cl. Sed., D3, D4	Right 1	1882 098	1882 098	----	----	----
		Left 1	1882 099	1882 099	----	----	----
	Sp.Cl.Cp.	Right 1	1882 100	1882 100	----	----	----
		Left 1	1882 101	1882 101	----	----	----
	Sp.Cl.Cp.	Front Right 1	----	----	1878 338	1878 338	----
		Left 1	----	----	1878 339	1878 339	----
		Rear Right 1	----	----	1878 340	1878 340	----
		Left 1	----	----	1878 341	1878 341	----
	Sub.	Right 1	1869 556	1869 556	----	1869 556	----
		Left 1	1869 557	1869 557	----	1869 557	----
	Sub.	Rear Right 1	1861 128	1861 128	----	1861 128	----
		Left 1	1861 129	1861 129	----	1861 129	----
	EXTENSION, Roof Side Rail Reinforcement						
	4 D., D1, D2	w/Low Window, Right 1	1882 130	1882 134	1882 134	1882 134	----
		Left 1	1882 131	1882 135	1882 135	1882 135	----
	4 D., D3, D4	w/Low Window, Right 1	----	1882 130	----	----	----
		Left 1	----	1882 131	----	----	----
	4 D., S3	w/High Window, Right 1	----	----	1952 648	----	----
		Left 1	----	----	1952 649	----	----
	Sp. 4 D., D1, S1, C1, C2	w/Low Window, Right 1	----	1882 134	1882 134	1882 134	----
		Left 1	----	1882 135	1882 135	1882 135	----
	D4	w/Low Window, Right 1	----	1882 130	----	----	----
		Left 1	----	1882 131	----	----	----
	Sp. 4 D., D3H, D4H	w/High Window, Right 1	1952 706	1952 706	----	----	----
		Left 1	1952 707	1952 707	----	----	----
	Sp. 4 D., D1, D2, S3	w/High Window, Right 1	----	1952 648	1952 648	1952 648	----
		Left 1	----	1952 649	1952 649	1952 649	----
	Sub.	Right 1	1960 064	1960 064	----	1960 064	----
		Left 1	1960 065	1960 065	----	1960 065	----
	Sp.Cl.Cp.	w/High Window, Right 1	1952 676	1952 676	----	----	----
		Left 1	1952 677	1952 677	----	----	----
	Sp.Cl.Cp., except Polara						
		w/Low Window, Right 1	1884 538	1884 538	----	----	----
		Left 1	1884 539	1884 539	----	----	----
	Cl.Sed.	Right 1	1882 130	1882 130	----	----	----
		Left 1	1882 131	1882 131	----	----	----
23-40-92	EXTENSION, Roof Side Rail						
	4 D., Cl.Sed., D3, D4	w/Low Window, Right 1	1884 638	1884 638	----	----	----
		Left 1	1884 639	1884 639	----	----	----
	4 D., D1, D2	w/Low Window, Right 1	----	1884 868	1884 868	1884 868	----
		Left 1	----	1884 869	1884 869	1884 869	----
	4 D., S3	w/High Window, Right 1	----	----	1952 650	----	----
		Left 1	----	----	1952 651	----	----
	Sp. 4 D., D1, S1, C1, C2						
		w/Low Window, Right 1	----	1884 868	1884 868	1884 868	----
		Left 1	----	1884 869	1884 869	1884 869	----
	Sp. 4 D., D3, D4	w/High Window, Right 1	1952 704	1952 704	----	----	----
		Left 1	1952 705	1952 705	----	----	----
	D1, D2, S3	w/High Window, Right 1	----	1952 650	1952 650	1952 650	----
		Left 1	----	1952 651	1952 651	1952 651	----
	Sp.Cl.Cp.	Right 1	----	----	----	----	1810 058
		Left 1	----	----	----	----	1810 059
	Sub.	Right 1	1961 422	1961 422	----	1961 422	----
		Left 1	1961 423	1961 423	----	1961 423	----
	4 D., Sp. 4 D.	Outer, Right 1	----	----	----	----	1877 408
		Left 1	----	----	----	----	1877 409
	EXTENSION, Roof Rail to Quarter Window						
	Front Frame, Sub.	Right 1	1961 018	1961 018	----	1961 018	----
		Left 1	1961 019	1961 019	----	1961 019	----

NOTE: For information on special equipment rear windows see 23-64-314.

★ Indicates use as required.
 ☐ Indicates parts not listed in any previous parts book.
 * Indicates change or addition.

CODE	REMARKS	PER CAR	PLYMOUTH	DODGE	DESOTO	CHRYSLER	IMPERIAL
23-40-0 ROOF RAIL AND LUGGAGE RACK - Cont'd							
23-40-94	ADAPTER, Roof Side Rear Inner Rail 4 D.	Right Left	1 1	---- ----	---- ----	---- ----	1877 668 1877 669
23-40-97	BRACE, Roof Side Rail to Wheelhouse Extension, Sp.Cl.Cp. w/High Window,	Right Left	1 1	1963 146 1963 147	1963 146 1963 147	---- ----	---- ----
23-40-150	RAIL, Roof Luggage Rack, Sub.	Side	2	----	2093 387	----	----
		Front and Rear	2	----	2093 388	----	----
23-40-170	SUPPORT, Roof Luggage Rack Rail, Sub.,	Right Left	3 3	----	2093 390 2093 391	----	----
23-40-177	CAP, Roof Luggage Rack Slats Frame Sub.	Front Rear	2 2	----	2093 382 2093 383	----	----
23-40-185	FRAME, Roof Luggage Rack Slats Sub.	Right Left	1 1	----	2093 380 2093 381	----	----
23-40-187	GASKET, Roof Luggage Rack Slats Frame Sub.		2	----	2093 394	----	----
	PAD, Roof Luggage Rack Slats, Sub.		9	----	2094 874	----	----
23-40-190	SLATS, Roof Luggage Rack, Sub.		9	----	2093 386	----	----
23-41-0 WINDOW LIFT (ELECTRIC)							
23-41-4	REGULATOR, Electric Window 4 D., Sp.4 D., 4 D.Sub.	Front Right Left	1 1	1964 364 1964 365	1964 364 1964 365	1964 364 1964 365	1860 966 1860 967
	4 D., 4 D.Sub.	Rear Right Left	1 1	1964 362 1964 363	1964 362 1964 363	1964 362 1964 363	1860 962 1860 963
	Sp. 4 D., Sp. 4 D.Sub.	Rear Right Left	1 1	1964 352 1964 353	1964 352 1964 353	1964 352 1964 353	1860 962 1860 963
	Sp.Cl.Cp., Cv.Cp., Cl.Sed., 2 D. Sub.	Door, Right Left	1 1	1964 360 1964 361	1964 360 1964 361	1964 360 1964 361	1860 963 1860 962
	Sp.Cl.Cp.	Quarter, Right Left	1 1	1964 356 1964 357	1964 356 1964 357	1964 356 1964 357	1753 706 1753 707
	Cv. Cp.	Quarter, Right Left	1 1	1964 354 1964 355	1964 354 1964 355	---- ----	1964 354 1964 355
	Cl.Sed., 2 D.Sub.	Quarter, Right Left	1 1	1964 358 1964 359	1964 358 1964 359	---- ----	---- ----
	REGULATOR, Electric Window (used in Dura Type Assembly) Sp.Cl.Cp., Cv.Cp., Cl.Sed., 2 D. Sub.	Door, Right Left	1 1	1964 598 1964 599	1964 598 1964 599	1964 598 1964 599	---- ----
	4 D., Sp.4D., Sp. 4 D. Sub	Front, Right Left	1 1	1964 596 1964 597	1964 596 1964 597	1964 596 1964 597	---- ----
23-41-5	BUS BAR, Electric Window Lift Circuit Breaker		1	*1498 776	*1498 776	*1498 776	*1498 776
23-41-7	SPRING, Electric Window Regulator	Doors Quarter	4 2	1964 289 1964 312	1964 289 1964 312	1964 289 1964 312	---- ----
	Sp.Cl.Cp.	Quarter	2	1964 289	1964 289	1964 289	----
	Cv.Cp., Cl.Sed., 2 D. Sub.	Quarter	4	----	----	1964 289	----
	All		4	----	----	----	1440 596
	SPRING, Electric Window Regulator (used in Dura Type Assembly) 4D., 4D. Sub.	Front Rear	2 2	2165 768 2165 768	2165 768 2165 768	2165 768 2165 768	---- ----
23-41-9	BOLT and WASHER, Electric Window Regulator		★	*1963 851	*1963 851	*1963 851	*1963 851
	SCREW, Electric Window Regulator	Front	4	1963 949	1963 949	1963 949	----
	STUD, Electric Window Regulator Pivot		★	6000 211	6000 211	6000 211	6000 211
23-41-11	CIRCUIT BREAKER, Electric Window Lift 30 amp.		1	1689 022	1689 022	1689 022	1689 022
23-41-12	CLIP, Electric Window Lift Circuit Breaker Mounting		1	*6015 159	*6015 159	*6015 159	*6015 159
23-41-25	RETAINER, Electric Window Lift Wiring Conduit	Front	2	*1886 949	*1886 949	*1886 949	*1886 949

★ Indicates use as required.

⊠ Indicates parts not listed in any previous parts book.

Dec. 9, 1960 Supersedes April 20, 1960.

Printed in U.S.A.

Prices and specifications subject to change without notice.

Page 23-88

* Indicates change or addition.

CODE	REMARKS	PER CAR	PLYMOUTH	DODGE	DESOTO	CHRYSLER	IMPERIAL
23-41-O WINDOW LIFT (ELECTRIC)- Cont'd							
23-41-29	BRACKET, Front Door Electric Window Lift Conduit Retaining, on Front Pillar	Right 1 Left 1	2094 422 2094 423	2094 422 2094 423	2094 422 2094 423	2094 422 2094 423	2094 422 2094 423
23-41-33	MECHANISM, Electric Window Lift 4 D., Sp. 4 D., 4 D. Sub.	Front 2 Rear 2 Right 2 Left 2	1963 827 1963 828 ---- ----	1963 827 1963 828 ---- ----	1963 827 1963 828 ---- ----	1963 827 1963 828 ---- ----	---- ---- 1860 942 1860 943
	Sp. Cl. Cp., Cv. Cp., Cl. Sed.	Door 2	1963 827	1963 827	1963 827	1963 827	----
	Door, Right	1	----	----	----	----	1860 943
	Left	1	----	----	----	----	1860 942
	Sp. Cl. Cp., Cv. Cp.	Quarter 2	1963 828	1963 828	1963 828	1963 828	----
	Quarter, Right	1	----	----	----	----	1819 169
	Left	1	----	----	----	----	1819 168
	Cl. Sed.	Quarter 2	1963 827	1963 827	----	----	----
23-41-53	BRACKET, Electric Window Regulator Mounting 4 D., Sp. 4 D., 4 D. Sub., Sp. 4 D. Sub.	Front Right 1 Left 1	1963 874 1963 875	1963 874 1963 875	1963 874 1963 875	1963 874 1963 875	---- ----
	Sp. 4 D., Sp. 4 D. Sub.	Rear Right 1 Left 1	1964 818 1964 819	1964 818 1964 819	1964 818 1964 819	1964 818 1964 819	---- ----
23-41-55	WIRING, Electric Window Lift, 4 D., 4 D. Sub.	1	1971 257	1971 257	1971 257	1971 257	----
	Sp. 4 D., Sp. 4 D. Sub.	1	1971 258	1971 258	1971 258	1971 258	----
	Sp. Cl. Cp., Cv. Cp., Cl. Sed., 2 D. Sub.	1	1971 256	1971 256	1971 256	1971 256	----
	4 D. w/Power Vent	1	----	----	----	----	2096 590
	Sp. Cl. Cp., Cv. Cp. w/Power Vent	1	----	----	----	----	2096 591
	4 D. w/Power Vent and Electric Door Locks	1	----	----	----	----	2096 444
	Sp. 4 D. w/Power Vent and Electric Door Locks	1	----	----	----	----	2096 515
	Sp. Cl. Cp., Cv. Cp. w/Power Vent and Electric Door Locks	1	----	----	----	----	2096 514
	Sp. Cl. Cp., Cv. Cp., Cl. Sed., 2 D. Sub.	1	1971 256	1971 256	1971 256	1971 256	2096 787
	4 D., 4 D. Sub., Y1L, Y1M	1	1971 257	1971 257	1971 257	1971 257	2096 788
	Sp. 4 D., Sp. 4 D. Sub., Y1L, Y1M	1	1971 258	1971 258	1971 258	1971 258	2096 786
	4 D. w/Electric Door Locks	1	----	----	----	----	2096 792
	Sp. 4 D. w/Electric Door Locks	1	----	----	----	----	2096 790
	Sp. Cl. Cp., Cv. Cp. w/Electric Door Locks	1	----	----	----	----	2096 791
	Sp. 4 D. w/Power Vent	1	----	----	----	----	2096 589
23-41-56	TERMINAL BLOCK, Quarter Electric Window Lift, Sp. Cl. Cp., Cv. Cp.	2	----	----	----	----	913 297
23-41-58	INSULATOR, Electric Window Lift Wiring Rear	2	1843 226	1843 226	1843 226	1843 226	----
23-41-62	WASHER, Electric Window Regulator Arm Stud to Glass Lower Channel	★	6000 141	6000 141	6000 141	6000 141	6000 141
23-41-94	RETAINER, Electric Window Regulator Arm Stud to Glass Lower Channel	8	*6000 305	*6000 305	*6000 305	*6000 305	----
23-41-95	GROMMET, Electric Window Lift Wiring Rear Door	2	⊠1952 584	⊠1952 584	⊠1952 584	⊠1952 584	----
23-41-106	MOTOR, Electric Window Lift 4 D., Cl. Sed., 4 D. Sub.	4	2084 445	2084 445	2084 445	2084 445	----
	Sp. 4 D., Sp. 4 D. Sub.	Front 2 Rear 2	2084 445 2084 445	2084 445 2084 445	2084 445 2084 445	2084 445 2084 445	2093 842 2093 843
	Sp. Cl. Cp., Cv. Cp.	Door 2	2084 445	2084 445	2084 445	2084 445	2093 842
	Sp. Cl. Cp.	Quarter 2	2084 446	2084 446	----	2084 446	2084 849
	Cv. Cp.	Quarter 2	2084 446	2084 446	----	2084 446	2084 849
	4 D.	Front 2 Rear 2	---- ----	---- ----	---- ----	---- ----	2093 842 2093 843
	MOTOR, Electric Window Lift (used in Dura Type Assembly)	Front Right 1 Left 1 Quarter, Right 1 Left 1	2196 343 2196 342 2196 343 2196 342	2196 343 2196 342 2196 343 2196 342	2196 343 2196 342 2196 343 2196 342	2196 343 2196 342 2196 343 2196 342	---- ---- ---- ----
	4D., 4D. Sub.	Rear, Right 1 Left 1	2196 343 2196 342	2196 343 2196 342	2196 343 2196 342	2196 343 2196 342	---- ----

★ Indicates use as required.
 ⊠ Indicates parts not listed in any previous parts book.
 * Indicates change or addition.

1960 PASSENGER CAR PARTS CATALOG

CODE	REMARKS	PER CAR	PLYMOUTH	DODGE	DESOTO	CHRYSLER	IMPERIAL
23-41-126	BUMPER, Electric Window Regulator Motor All	★	----	----	----	----	1860 619
23-41-128	GROMMET, Electric Window Lift Motor Mounting						
	Quarter	4	----	----	----	----	1383 351
	GROMMET, Electric Window Lift Wiring Conduit						
	Rear	2	⊠2257 744	⊠2257 744	⊠2257 744	⊠2257 744	----
23-41-129	WASHER, Electric Window Regulator Mounting SCREW, Electric Window Regulator Motor Strap	★	*6006 065	*6006 065	*6006 065	*6006 065	----
23-41-130	LOCKWASHER, Electric Window Regulator Mounting	★	----	----	----	----	*6006 249
23-41-138	SHAFT, Electric Window Lift Motor to Mechanism						
	Front	2	1627 108	1627 108	1627 108	1627 108	1627 108
	Rear	2	1688 919	1688 919	1688 919	1688 919	1688 919
	Sp. Cl. Cp., Cv. Cp., Cl. Sed. Quarter	2	1688 919	1688 919	1688 919	1688 919	1627 108
	Coupling and Drive Cable, Electric Window Lift Motor to Mechanism (used in Dura Type Assembly)						
	Front and Rear	2	1810 641	1810 641	1810 641	1810 641	----
	Quarter	2	1810 341	1810 641	1810 641	1810 641	----
23-41-139	SHIELD, Electric Window Lift Motor Shaft	★	*1689 167	*1689 167	*1689 167	*1689 167	*1689 167
23-41-167	CONDUIT, Electric Window Lift Wiring						
	Rear	2	1971 314	1971 314	1971 314	1971 314	----
23-41-170	SWITCH, Electric Window Lift 4 Gang, Includes BEZEL	1	2096 089	2096 089	2096 089	2096 089	*2096 090
	Single, Includes BEZEL	3	2096 399	2096 399	2096 399	2096 399	2096 765
	SWITCH, Electric Window Lift Safety	1	2197 404	2197 404	2197 404	2197 404	2197 404
	SWITCH, Electric Window Lift and Vent Wing 6 Gang, Includes BEZEL	1	----	----	----	----	2096 176
	2 Gang, Includes BEZEL	1	----	----	----	----	2096 177
23-41-174	SPRING, Electric Window Lift Switch Retaining	★	*2096 169	*2096 169	*2096 169	*2096 169	*2096 169
23-41-176	CONNECTOR, Electric Window Lift Switch						
	Single	★	2096 905	2096 905	2096 905	2096 905	2096 905
	4 Way	★	*2096 908	*2096 908	*2096 908	2096 908	*2096 908
	5 Way	★	*2096 911	*2096 911	*2096 911	2096 911	*2096 911
	CONNECTOR, Electric Window Lift Safety Switch	1	1345 871	1345 871	1345 871	1345 871	1345 871
23-41-177	TERMINAL, Electric Window Lift Safety Switch	4	903 895	903 895	903 895	903 895	903 895
23-41-178	SLEEVE, Electric Window Lift Safety Switch	3	1264 933	1264 933	1264 933	1264 933	1264 933
23-41-184	RETAINER, Electric Window Lift Switch and Bezel						
	Left Front Door	1	*1769 330	*1769 330	*1769 330	*1769 330	*1769 330
	Except Left Front Door	3	⊠1971 478	⊠1971 478	⊠1971 478	⊠1971 478	⊠1971 478
23-41-250	ROLLER, Electric Window Regulator Guide Arm Plate, Sp. 4 D.						
	Rear	6	----	----	----	----	2094 112
23-41-259	WASHER, Electric Window Regulator Arm and Link Anti-Rattle	8	----	----	----	----	*2093 129
23-41-260	SLEEVE, Electric Window Regulator Arm and Link Anti-Rattle	8	----	----	----	----	*2093 130
23-41-261	SPRING, Electric Window Regulator Arm and Link Anti-Rattle	8	----	----	----	----	*2093 131
23-41-270	HOUSING and PINION, Electric Window Regulator (used in Dura Type Assembly)						
	9 Teeth,						
	Front Right	1	2165 680	2165 680	2165 680	2165 680	----
	Left	1	2165 681	2165 681	2165 681	2165 681	----
	4D., 4D. Sub.						
	Rear Right	1	2165 680	2165 680	2165 680	2165 680	----
	Left	1	2165 681	2165 681	2165 681	2165 681	----
	6 Teeth,						
	Quarter Right	1	2165 718	2165 718	2165 718	2165 718	----
	Left	1	2165 719	2165 719	2165 719	2165 719	----
23-41-273	BUSHING or BEARING, Electric Window Lift Mechanism Gear Shaft (used in Dura Type Assembly)						
	Outer	2	*1810 635	*1810 635	*1810 635	*1810 635	----
	Inner	2	*1810 648	*1810 648	*1810 648	*1810 648	----

★ Indicates use as required.

⊠ Indicates parts not listed in any previous parts book.

Dec. 9, 1960 Supersedes April 20, 1960.

Printed in U.S.A.

Prices and specifications subject to change without notice.

* Indicates change or addition.

CODE	REMARKS	PER CAR	PLYMOUTH	DODGE	DESOTO	CHRYSLER	IMPERIAL
23-41-O WINDOW LIFT (ELECTRIC) - Cont'd							
23-41-281	BRACE, Door Inside Panel Electric Window Regulator Lower Sp. Cl. Cp., Cv. Cp., Cl. Sed. 4 D., Sp. 4 D., 4 D. Sub., Sp. 4 D. Sub.	2 2	1964 821 1964 823	1964 821 1964 823	1964 821 1964 823	1964 821 1964 823	---- ----
	REINFORCEMENT, Rear Door Inside Panel Electric Window Regulator 4 D., 4 D. Sub.						
	Upper, Right	1	1964 690	1964 690	1964 690	1964 690	----
	Left	1	1964 691	1964 691	1964 691	1964 691	----
	Front, Right	1	1964 696	1964 696	1964 696	1964 696	----
	Left	1	1964 697	1964 697	1964 697	1964 697	----
23-42-O WINDOW GLASS RUN							
23-42-13	RUN, Door Window Glass Division Channel 4 D.						
	Right	1	----	----	----	----	1877 562
	Left	1	----	----	----	----	1877 563
	Sp. 4 D., Sp. Cl. Cp., Cv. Cp.						
	Right	1	----	----	----	----	2093 836
	Left	1	----	----	----	----	2093 837
23-42-16	RUN, Front Door Window Glass 4 D., 4 D. Sub.	2	2165 492	2165 492	2165 492	2165 492	----
	4 D.						
	Upper	2	----	----	----	----	1961 541
	Rear	2	----	----	----	----	1751 538
	RUN, Door Window Glass, Cl. Sed., 2 D. Sub.	2	2165 492	2165 492	----	----	----
23-42-23	RUN, Rear Door Window Glass 4 D., 4 D. Sub.	2	2165 492	2165 492	2165 492	2165 492	2093 440
23-42-26	RETAINER, Front Door Window Glass Run 4 D., 4 D. Sub., Cl. Sed., 2 D. Sub.						
	Right	1	1952 378	1952 378	1952 378	1952 378	----
	Left	1	1952 379	1952 379	1952 379	1952 379	----
	RETAINER, Rear Door Window Glass Run 4 D., 4 D. Sub.						
	Right	1	1954 144	1954 144	1954 144	1954 144	----
	Left	1	1954 145	1954 145	1954 145	1954 145	----
23-42-38	RUN, Quarter Window Glass Cl. Sed., 2 D. Sub.	2	2165 492	2165 492	----	----	----
	Sp. Cl. Cp.						
	Roof Side Rail, Right	1	----	----	----	----	2094 154
	Left	1	----	----	----	----	2094 155
23-42-46	RUN, Tailgate Window Glass Sub.						
	In Tailgate	2	1961 556	1961 556	----	1961 556	----
	On Body	1	1961 555	1961 555	----	1961 555	----
23-42-56	RETAINER, Quarter Window Glass Run Cl. Sed., 2 D. Sub.						
	Right	1	1909 386	1909 386	----	----	----
	Left	1	1909 387	1909 387	----	----	----
23-42-57	FILLER, Quarter Window Glass Run to Roof Rear Side Rail, Rubber, Sp. Cl. Cp.						
	Right	1	----	----	----	----	2094 156
	Left	1	----	----	----	----	2094 157
23-45-O FRONT SEAT							
23-45-11	WASHER, Swivel Seat Upper Frame Lower Pivot Arm	2	2094 167	2094 167	2094 167	2094 167	2094 167
	WASHER, Swivel Seat Upper Frame Lower Pivot Bracket	2	2094 168	2094 168	2094 168	2094 168	2094 168
23-45-12	ROLLER, Swivel Seat Cushion Frame Pivot Track	4	*1918 529	*1918 529	*1918 529	*1918 529	*1918 529
23-45-17	BRACKET, Swivel Seat Adjuster Stabilizer to Floor Mounting	1	2161 057	2161 057	2161 057	2161 057	----
23-45-18	FRAME, Swivel Seat Lower						
	w/Manual Seat Adjuster	1	2092 230	2092 230	2092 230	2092 230	2092 230
	w/Electric Seat Adjuster	1	2092 231	2092 231	2092 231	2092 231	2092 231
	C3-300 w/Manual Seat Adjuster	1	----	----	----	2092 226	----
	w/Electric Seat Adjuster	1	----	----	----	2092 187	----
23-45-20	SPRING, Swivel Seat Cushion Frame to Lower Frame Tension	2	*1918 551	*1918 551	*1918 551	*1918 551	*1918 551
	SPRING, Swivel Seat Cushion Frame Lower Seat Opening Assist	2	2094 069	2094 069	2094 069	2094 069	2094 069
	SUPPORT, Swivel Seat Center Cushion Frame Tension Wire w/Manual Seat Adjuster	1	1969 032	1969 032	1969 032	1969 032	1969 032

★ Indicates use as required.

□ Indicates parts not listed in any previous parts book.

* Indicates change or addition.

CODE	REMARKS	PER CAR	PLYMOUTH	DODGE	DESOTO	CHRYSLER	IMPERIAL
23-45-0 FRONT SEAT - Cont'd							
23-45-21	BRACKET, Swivel Seat Center Cushion Frame Tension Wire	2	----	*1969 200	*1969 200	*1969 200	----
23-45-22	STABILIZER, Swivel Seat Cushion Frame						
	Right	1	2094 200	2094 200	2094 200	2094 200	2094 200
	Left	1	2094 201	2094 201	2094 201	2094 201	2094 201
23-45-24	SUPPORT, Front Seat Cushion Release Wire C3-300	1	----	----	----	2092 241	----
23-45-25	RAMP, Swivel Seat Cushion Frame Stabilizer	2	2094 149	2094 149	2094 149	2094 149	2094 149
23-45-30	BUMPER, Front Seat Back Stop Sp. Cl. Cp., Cv. Cp., Cl. Sed., 2D. Sub., except Swivel Seats	2	1815 328	1815 328	1815 328	1815 328	1815 328
23-45-33	BRACKET, Front Seat Back Outer Hinge Arm Cover						
	Sp. Cl. Cp., Cv. Cp., Cl. Sed., 2D. Sub. D3, D4, S1						
	Right	1	2080 944	2080 944	2080 944	----	----
	Left	1	2080 945	2080 945	2080 945	----	----
23-45-35	BRACKET, Swivel Seat Door Hinge Lower Torsion Spring						
	Right	1	2094 438	2094 438	2094 438	2094 438	2094 438
	Left	1	2094 439	2094 439	2094 439	2094 439	2094 439
23-45-43	BRACKET and RETAINER, Swivel Seat Cushion Frame Pivot						
	C3-300	2	----	----	----	2094 896	----
23-45-52	HANDLE, Swivel Seat Latch Tapered Type	2	2080 187	2080 187	2080 187	2080 187	2080 187
23-45-53	SCREW, Swivel Seat Latch Handle to Shaft Attaching	2	*1902 031	*1902 031	*1902 031	*1902 031	*1902 031
23-45-54	WASHER, Swivel Seat Latch Handle to Cushion	2	*2080 317	----	----	----	----
23-45-56	SCREW, Swivel Seat Back Tension Adjusting	★	6016 005	6016 005	6016 005	6016 005	6016 005
23-45-58	SCREW, Swivel Seat Back Pivot Bracket Cover Attaching	4	1901 691	1901 691	1901 691	1901 691	1901 691
23-45-59	SPRING, Swivel Seat Cushion Frame Lower Return	2	2094 067	2094 067	2094 067	2094 067	2094 067
23-45-61	BUSHING, Swivel Seat Cushion Frame Lower Pivot	2	2094 098	2094 098	2094 098	2094 098	2094 098
23-45-62	NUT, Swivel Seat Cushion Frame Pivot Bracket, C3-300	2	----	----	----	2094 888	----
23-45-75	FASTENER, Swivel Seat Adjuster Cover to Seat Bottom Frame	2	2161 331	2161 331	2161 331	2161 331	2161 331
23-45-77	PULLEY and BEARING, Swivel Seat Cushion Lower Frame	2	2094 197	2094 197	2094 197	2094 197	2094 197
23-45-79	CABLE, Swivel Seat Actuating Cable						
	Door, Half	2	2094 103	2094 103	2094 103	2094 103	2094 103
	Seat, Half	2	2094 278	2094 278	2094 278	2094 278	2094 278
23-45-80	SEAL, Swivel Seat Actuating Cable Retaining Bracket to Pillar	2	2094 063	2094 063	2094 063	2094 063	2094 063
23-45-87	BRACKET, Swivel Seat Lower Door Hinge Actuating Cable Pin	2	2094 055	2094 055	2094 055	2094 055	2094 055
23-45-89	BOLT, Swivel Seat Lower Door Hinge Actuating Cable Bracket	2	2094 060	2094 060	2094 060	2094 060	2094 060
23-45-91	BRACKET, Swivel Seat Actuating Cable Housing Mounting on Front Pillar						
	Right	1	2094 150	2094 150	2094 150	2094 150	2094 329
	Left	1	2094 151	2094 151	2094 151	2094 151	2094 329
23-45-95	BRACKET, Front Pillar Upper Hinge Reinforcement Assist Spring Retaining w/Swivel Seats						
	Right	1	2094 300	2094 300	2094 300	2094 300	2094 306
	Left	1	2094 301	2094 301	2094 301	2094 301	2094 307
23-45-96	SPRING, Front Pillar Hinge Assist w/Swivel Seats	2	2094 303	2094 303	2094 303	2094 303	2094 303
23-45-99	ARM, Swivel Seat Cushion Frame Lower Pivot Actuating						
	Right	1	2094 094	2094 094	2094 094	2094 094	----
	Left	1	2094 095	2094 095	2094 095	2094 095	----
23-45-100	LEVER, Swivel Seat Lower Frame Actuating Catch						
	Right	1	2094 400	2094 400	2094 400	2094 400	2094 400
	Left	1	2094 401	2094 401	2094 401	2094 401	2094 401

★ Indicates use as required.

☐ Indicates parts not listed in any previous parts book.
Dec. 9, 1960 Supersedes April 20, 1960.Printed in U.S.A.
Prices and specifications subject to change without notice.

* Indicates change or addition.

CODE	REMARKS	PER CAR	PLYMOUTH	DODGE	DESOTO	CHRYSLER	IMPERIAL
23-45-0 FRONT SEAT - Cont'd							
23-45-101	ROD, Swivel Seat Lower Frame Actuating Catch C3-300	2 2	2094 404 ----	2094 404 ----	2094 404 ----	2094 404 2094 655	2094 404 ----
23-45-102	CATCH and BRACKET, Swivel Seat Lower Frame Actuating C3-300	Right 1 Left 1 Right 1 Left 1	2094 396 2094 397 ---- ----	2094 396 2094 397 ---- ----	2094 396 2094 397 ---- ----	2094 396 2094 397 2188 518 2188 519	2094 396 2094 397 ---- ----
23-45-103	BOLT, Swivel Seat Lower Frame Actuating Rod to Catch	2	2094 434	2094 434	2094 434	2094 434	2094 434
23-45-104	SPRING, Swivel Seat Lower Frame Catch Actuating Lever	2	2094 446	2094 446	2094 446	2094 446	2094 446
23-45-105	SPRING, Swivel Seat Lower Frame Catch Actuating Pawl	Right 1 Left 1	2094 414 2094 415	2094 414 2094 415	2094 414 2094 415	2094 414 2094 415	2094 414 2094 415
23-45-106	SPRING, Swivel Seat Lower Frame Support to Catch	2	2094 413	2094 413	2094 413	2094 413	2094 413
23-45-110	NUT, Swivel Seat Lower Frame Actuating Catch Lever	2	2094 445	2094 445	2094 445	2094 445	2094 445
23-45-111	RIVET, Swivel Seat Lower Frame Actuating Catch Support	2	2094 444	2094 444	2094 444	2094 444	2094 444
23-45-112	HOOK, Swivel Seat Frame to Lower Pivot Arm Retainer C3-300	2 2	2188 558 ----	2188 558 ----	2188 558 ----	2188 558 2188 411	2188 558 ----
23-45-113	U/NUT, Swivel Seat Lower Frame Actuating Rod Catch	2	2094 460	2094 460	2094 460	2094 460	2094 460
23-45-115	SCREW, Swivel Seat Actuating Catch Support to Lower Frame	2	9415 101	9415 101	9415 101	9415 101	9415 101
23-47-0 FRONT SEAT ADJUSTER							
23-47-6	GUIDE or TRACK, Manual 6 Way Seat Adjuster	Upper Right 1 Left 1 Lower Right 1 Left 1	2080 956 2080 957 2080 952 2080 953	2080 956 2080 957 2080 952 2080 953	2080 956 2080 957 2080 952 2080 953	2080 956 2080 957 2080 952 2080 953	2080 956 2080 957 2080 952 2080 953
	ADJUSTER, Manual Seat, Y1-L	Right 1 Left 1	---- ----	2080 904 2080 905	2080 904 2080 905	2080 904 2080 905	2080 904 2080 905
	GUIDE or TRACK, Electric Seat Adjuster	Right 1 Left 1	2080 828 2080 827	2080 828 2080 827	2080 828 2080 827	2080 828 2080 827	2080 828 2080 827
	w/Swivel Seats, Right	1	----	----	----	----	2080 828
	w/Swivel Seats, Left	1	----	----	----	----	2080 827
23-47-8	COVER, Swivel Seat Adjuster Track	Right 1 Left 1	1916 840 1916 852	1916 840 1916 852	1916 840 1916 852	1916 840 1916 852	1916 840 1916 852
	COVER, Electric Seat Adjuster Track, except w/Swivel Seats	Right 1 Left 1	1839 386 1839 387	1839 386 1839 387	1839 386 1839 387	1839 386 1839 387	1839 386 1839 387
	COVER, Electric Seat Adjuster Track Floor Pan Well	Right 1 Left 1	---- ----	---- ----	---- ----	---- ----	1902 108 1902 109
	NOTE: With 1916 852 Cover also specify 1 of 1902 186 Name Plate.						
23-47-9	STUD, Electric Seat Adjuster to Floor BOLT and WASHER, Manual Seat Guide Support	8 4	6008 111 6008 220	6008 111 6008 220	6008 111 6008 220	6008 111 6008 220	6008 111 6008 220
23-47-12	STOP, Electric Seat Adjuster Track Horizontal	Right 1 Left 1	1830 236 1830 237	1830 236 1830 237	1830 236 1830 237	1830 236 1830 237	1830 236 1830 237
23-47-14	SCREW, Swivel Seat Adjuster Track Cover Attaching, All	8	1901 691	1901 691	1901 691	1901 691	1901 691
23-47-16	NUT, Front Seat Guide Support	Front 2 Rear 2	2080 951 120 377	2080 951 120 377	2080 951 120 377	2080 951 120 377	2080 951 120 377
23-47-26	SPRING, Manual Seat Guide Tension	2	1902 350	1902 350	1902 350	1902 350	1902 350
23-47-35	NUT and WASHER, Seat Guide to Floor Pan	8	6000 243	6000 243	6000 243	6000 243	6000 243

★ Indicates use as required.

□ Indicates parts not listed in any previous parts book.

* Indicates change or addition.

CODE	REMARKS	PER CAR	PLYMOUTH	DODGE	DESOTO	CHRYSLER	IMPERIAL
23-47-O FRONT SEAT ADJUSTER - Cont'd							
23-47-55	KNOB, Manual Seat Guide Latch	1	1902 217	2161 291	2161 291	2161 291	2161 291
23-47-64	CLIP, Front Seat Guide Connecting Wire, All	1	1969 366	1969 366	1969 366	1969 366	1969 366
23-47-66	WIRE, Manual Seat Guide Latch Connector						
	w/o Swivel Seats	1	1969 367	1969 367	1969 367	1969 367	1969 367
	w/ Swivel Seats	1	2092 184	2092 184	2092 184	2092 184	----
23-47-75	SPRING, Manual Seat Guide Latch	2	*1645 615	*1645 615	*1645 615	*1645 615	*1645 615
23-47-196	PIN, Electric Seat Adjuster Track Rear Lever and Guard to Base	2	*6008 216	*6008 216	*6008 216	*6008 216	*6008 216
23-47-344	UNIT or MECHANISM, Electric Seat Adjuster Drive	1	*1819 228	*1819 228	*1819 228	*1819 228	*1819 228
23-47-350	DOWEL PIN, Electric Seat Adjuster Drive Unit	2	----	*6008 051	*6008 051	*6008 051	*6008 051
23-47-352	SCREW, Electric Seat Adjuster Drive Unit	6	*6008 126	*6008 126	*6008 126	*6008 126	*6008 126
	SCREW, Electric Seat Adjuster Slave Unit Cap or Cover	16	*6008 027	*6008 027	*6008 027	*6008 027	*6008 027
23-47-375	STUD, Electric Seat Adjuster Stabilizer to Floor Bracket	1	*2080 456	*2080 456	*2080 456	*2080 456	*2080 456
23-47-383	PIVOT END, Electric Seat Adjuster Stabilizer Strut	2	*2080 329	*2080 329	*2080 329	*2080 329	*2080 329
23-47-384	STRUT, Electric Seat Adjuster Stabilizer						
	Female	1	2080 330	2080 330	2080 330	2080 330	2080 330
	Male	1	2080 331	2080 331	2080 331	2080 331	2080 331
23-47-385	STUD, Electric Seat Adjuster Stabilizer Pivot End to Floor Bracket, All	1	2080 456	2080 456	2080 456	2080 456	2080 456
23-47-386	WASHER, Electric Seat Adjuster Stabilizer Pivot End	2	*2080 466	*2080 466	*2080 466	*2080 466	*2080 466
23-47-387	GUARD, Electric Seat Adjuster Track Rear Lever	2	*2080 478	*2080 478	*2080 478	*2080 478	*2080 478
23-47-413	SPRING, Electric Seat Adjuster Drive Unit Gear Selector Lever and Shaft	3	*1819 230	*1819 230	*1819 230	*1819 230	*1819 230
23-47-414	COIL PACKAGE, Electric Seat Adjuster Drive Unit Solenoid	3	*1830 290	*1830 290	*1830 290	*1830 290	*1830 290
23-47-423	CIRCUIT BREAKER, Electric Seat Adjuster						
	30 amp.	1	1689 022	----	----	----	----
	40 amp.	1	----	1769 967	1769 967	1769 967	1769 967
23-47-424	CLIP, Electric Seat Adjuster Circuit Breaker Mounting	1	6015 159	6015 159	6015 159	6015 159	----
23-47-425	RELAY, Electric Seat Adjuster	1	1779 890	1779 890	1779 890	1779 890	1779 890
23-47-427	SCREW and WASHER, Electric Seat Adjuster Relay Mounting	2	6008 110	6008 110	6008 110	6008 110	6008 110
23-47-430	MOTOR, Electric Seat Adjuster	1	1779 055	1779 055	1779 055	1779 055	1779 055
23-47-431	TUBE, Electric Seat Adjuster Drive Unit to Slave Unit Cable, Front Control, Left, Short	1	1830 216	1830 216	1830 216	1830 216	1830 216
	Rear Control, Left, Short	1	1830 217	1830 217	1830 217	1830 217	1830 217
	Horizontal Control, Left, Short	1	1830 218	1830 218	1830 218	1830 218	1830 218
	w/BRACKETS, Right, Long	1	1830 212	1830 212	1830 212	1830 212	1830 212
23-47-432	COUPLING, Electric Seat Adjuster Motor to Mechanism or Drive Unit	1	1594 834	1594 834	1594 834	1594 834	1594 834
	CABLE, Electric Seat Adjuster Drive Unit to Slave Unit Front Control, Right, 50 5/16"	1	1830 344	1830 344	1830 344	1830 344	1830 344
	Left, 10 25/32"	1	1830 345	1830 345	1830 345	1830 345	1830 345
	Rear Control, Right, 48"	1	1830 346	1830 346	1830 346	1830 346	1830 346
	Left, 10"	1	1830 347	1830 347	1830 347	1830 347	1830 347
	Horizontal Control, Right, 50 13/16"	1	1830 348	1830 348	1830 348	1830 348	1830 348
	Left, 12 5/32"	1	1830 349	1830 349	1830 349	1830 349	1830 349
23-47-434	THRU BOLT, Electric Seat Adjuster Motor w/AutoLite Motor	1	----	1818 904	1818 904	1818 904	1818 904
23-47-446	SWITCH, Electric Seat Adjuster						
	w/Swivel Seats	1	2096 658	2096 658	2096 658	2096 658	2096 658
	w/o Swivel Seats	1	1972 598	1972 598	1972 598	1972 598	1972 598
23-47-451	BEZEL, Electric Seat Adjusting Switch						
	w/Swivel Seats	1	2080 946	2080 946	2080 946	2080 946	2080 946
	S1 w/o Swivel Seats	1	2161 261	----	2161 261	----	----
23-47-454	BRUSH and SPRING PACKAGE, Electric Seat Adjuster Motor						
	w/AutoLite Motor	1	----	1495 533	1495 533	1495 533	1495 533
	w/Redmond Motor	1	----	1297 879	1297 879	1297 879	1297 879

★ Indicates use as required.

☐ Indicates parts not listed in any previous parts book.

Dec. 9, 1960 Supersedes April 20, 1960.

Page 23-94

Printed in U.S.A.
Prices and specifications subject to change without notice.

* Indicates change or addition.

CODE	REMARKS	PER CAR	PLYMOUTH	DODGE	DESOTO	CHRYSLER	IMPERIAL
23-47-O FRONT SEAT ADJUSTER - Cont'd							
23-47-457	KNOB, Electric Seat Adjuster Switch	1	2096 022	2096 022	2096 022	2096 022	2096 022
23-47-458	STUD, Electric Seat Adjuster Switch Bezel S1	2	6010 020	----	6010 020	----	----
23-48-O SECOND AND THIRD SEAT							
23-48-6	SPACER, Seat Back to Cushion, Down Position Sub.	★	1884 737	1884 737	----	1884 737	----
23-48-11	PIN, Third Seat Back Hinge Sub.	2	1960 627	1960 627	----	1960 627	----
23-48-19	STRIKER, Seat Back Up Position Sub.	1	1961 438	1961 438	----	1961 438	----
	Second Seat, Right	1	1961 438	1961 438	----	1961 438	----
	Left	1	1961 439	1961 439	----	1961 439	----
	Third Seat	2	1960 503	1960 503	----	1960 503	----
	LATCH, Third Seat Back Up Position, on Wheelhouse Sub.	2	1775 440	1775 440	----	1775 440	----
23-48-20	HANDLE, Third Seat Lift Sub.	2	1833 596	1833 596	----	1833 596	----
	Chrome	2	1833 596	1833 596	----	1833 596	----
23-48-21	ESCUTCHEON, Third Seat Lift Handle Sub.	2	1775 814	1775 814	----	1775 814	----
	In Prime	2	1775 814	1775 814	----	1775 814	----
	Chrome	2	1833 597	1833 597	----	1833 597	----
23-48-28	BRACKET, Seat Back Up Position, on Wheelhouse Sub.	1	1961 230	1961 230	----	1961 230	----
	Second Seat, Right	1	1961 231	1961 231	----	1961 231	----
	Left	2	1878 641	1878 641	----	1878 641	----
	Third Seat	1	1961 091	1961 091	----	1961 091	----
23-48-49	ROD, Second Seat Back Latch Actuating Sub.	2	1961 085	1961 085	----	1961 085	----
23-48-50	PIN, Second Seat Back Latch Handle Stop Sub.	1	1961 436	1961 436	----	1961 436	----
23-48-51	HANDLE, Second Seat Back Latch Sub.	1	1961 437	1961 437	----	1961 437	----
	Right	1	1961 436	1961 436	----	1961 436	----
	Left	1	1961 437	1961 437	----	1961 437	----
23-48-52	SPRING, Second Seat Back Latch Handle Retaining Sub.	1	1961 692	1961 692	----	1961 692	----
	Right	1	1961 693	1961 693	----	1961 693	----
	Left	1	1878 652	1878 652	----	1878 652	----
23-48-65	PANEL and HINGES, Second Seat Back Sub.	1	2093 646	2093 646	----	2093 646	----
23-48-78	SPRING, Second Seat Cushion Leg Sub.	1	2093 647	2093 647	----	2093 647	----
	Right	1	2093 646	2093 646	----	2093 646	----
	Left	1	2093 647	2093 647	----	2093 647	----
23-48-87	SUPPORT and PIN, Second Seat Cushion Hinge Sub.	1	1877 926	1877 926	----	1877 926	----
	Right	1	1877 927	1877 927	----	1877 927	----
	Left	1	1877 927	1877 927	----	1877 927	----
23-48-93	BUMPER, Seat Cushion Bottom Sub.	★	1380 060	1380 060	----	1380 060	----
	BUMPER, Second Seat Back Up Position, on Wheelhouse Sub.	2	1380 060	1380 060	----	1380 060	----
	BUMPER, Third Seat Back Up Position, on Wheelhouse Bracket Sub.	2	1835 109	1835 109	----	1835 109	----
23-48-94	RETAINER, Third Seat Back Up Position Latch and Bumper Mounting Screw Sub.	2	6000 177	6000 177	----	6000 177	----
23-48-98	HINGE and BEARING, Second Seat Bottom Sub.	1	*1878 910	*1878 910	----	*1878 910	----
	Right	1	*1878 911	*1878 911	----	*1878 911	----
	Left	1	2093 236	2093 236	----	2093 236	----
23-48-101	LEG, Second Seat Cushion Sub.	1	2093 237	2093 237	----	2093 237	----
	Right	1	2093 236	2093 236	----	2093 236	----
	Left	1	2093 237	2093 237	----	2093 237	----

★ Indicates use as required.

☐ Indicates parts not listed in any previous parts book.

* Indicates change or addition.

CODE	REMARKS	PER CAR	PLYMOUTH	DODGE	DESOTO	CHRYSLER	IMPERIAL
23-48-O SECOND AND THIRD SEAT - Cont'd							
23-48-105	SPACER, Second Seat Bottom Hinge Support to Floor Pan						
	Sub.						
	Front	2	⊠2188 616	⊠2188 616	----	⊠2188 616	----
	Rear	2	⊠2188 617	⊠2188 617	----	⊠2188 617	----
23-48-108	SPRING, Second Seat Bottom Leg						
	Sub.						
	Right	1	2093 646	2093 646	----	2093 646	----
	Left	1	2093 647	2093 647	----	2093 647	----
23-48-112	PANEL and HINGES, Second Seat Cushion Bottom						
	Sub.	1	1878 769	1878 769	----	1878 769	----
23-48-116	WASHER, Second Seat Bottom Leg to Pivot Bolt						
	Sub.	2	⊠6022 153	⊠6022 153	----	⊠6022 153	----
23-48-121	HINGE, Third Seat						
	Sub.						
	Body, Right	1	1878 170	1878 170	----	1878 170	----
	Left	1	1878 171	1878 171	----	1878 171	----
	Cushion, Right	1	2094 130	2094 130	----	2094 130	----
	Left	1	2094 131	2094 131	----	2094 131	----
	HINGE, Third Seat Bottom						
	Sub.						
	Body Half, Right	1	*2094 130	*2094 130	----	*2094 130	----
	Left	1	*2094 131	*2094 131	----	*2094 131	----
23-48-148	PIN, Second Seat Back Pivot						
	Sub.						
	Includes BRACKET, Right	1	1878 600	1878 600	----	1878 600	----
	Left	1	1878 601	1878 601	----	1878 601	----
23-48-149	WASHER, Second Seat Cushion Hinge Pin						
	Sub.	2	6000 097	6000 097	----	6000 097	----
23-48-166	SCREW and WASHER, Second Seat Cushion Hinge Support to Floor Pan						
	Sub.	6	1244 818	1244 818	----	1244 818	----
23-48-180	PANEL and HINGES, Third Seat Cushion Bottom						
	Sub.	1	1878 755	1878 755	----	1878 755	----
23-48-188	PANEL and HINGES, Third Seat Back						
	Sub.	1	1878 592	1878 592	----	1878 592	----
23-51-O SIDE SILL AND BELT BAR							
23-51-3	SILL, Body Side						
	4 D., Sp. 4 D.						
	Outer, Right	1	----	----	----	----	2084 532
	Left	1	----	----	----	----	2084 533
	Inner, Right	1	----	----	----	----	1861 352
	Left	1	----	----	----	----	1861 353
	Sp. Cl. Cp., Cv. Cp.						
	Outer, Right	1	----	----	----	----	2084 530
	Left	1	----	----	----	----	2084 531
	Inner, Right	1	----	----	----	----	1877 994
	Left	1	----	----	----	----	1877 995
23-51-5	PANEL, Body Side Sill Outer						
	4 D., D3, D4, C1, C2						
	Right	1	*1952 874	*1952 874	*1952 962	*1952 962	----
	Left	1	1952 875	1952 875	1952 963	1952 963	----
	4 D., D1, D2, C3						
	Right	1	----	*1952 962	----	*1952 916	----
	Left	1	----	1952 963	----	1952 917	----
	Sp. 4 D., Sp. 4 D. Sub., except Phoenix and Windsor						
	Right	1	1952 882	1952 912	1952 912	1952 918	----
	Left	1	1952 883	1952 913	1952 913	1952 919	----
	Sp. 4 D., Sp. 4 D. Sub., D3H, D4H, C1						
	Right	1	----	1952 882	----	1952 912	----
	Left	1	----	1952 883	----	1952 913	----
	Sp. Cl. Cp., D3, D4, C1						
	Right	1	1952 884	1952 884	1952 960	1952 960	----
	Left	1	1952 885	1952 885	1952 961	1952 961	----
	Sp. Cl. Cp., D1, D2, C2, C3						
	Right	1	----	1952 960	----	1952 920	----
	Left	1	----	1952 961	----	1952 921	----
	Cv. Cp., D2, C3						
	Right	1	1952 922	1952 924	----	1952 926	----
	Left	1	1952 923	1952 925	----	1952 927	----
	Cv. Cp., D4, C1						
	Right	1	----	1952 922	----	1952 924	----
	Left	1	----	1952 923	----	1952 925	----
	4 D. Sub.						
	Right	1	1952 962	1952 962	----	----	----
	Left	1	1952 963	1952 963	----	----	----

★ Indicates use as required.

⊠ Indicates parts not listed in any previous parts book.

Dec. 9, 1960 Supersedes April 20, 1960.

Printed in U.S.A.

Prices and specifications subject to change without notice.

* Indicates change or addition.

CODE	REMARKS	PER CAR	PLYMOUTH	DODGE	DESOTO	CHRYSLER	IMPERIAL
23-51-O SIDE SILL AND BELT BAR - Cont'd							
23-51-5	PANEL - Cont'd						
	2 D. Sub.	Right 1	1952 960	----	----	----	----
		Left 1	1952 961	----	----	----	----
	Cl. Sed.	Right 1	1952 884	1952 884	----	----	----
		Left 1	1952 885	1952 885	----	----	----
	PANEL, Body Side Sill Inner	Front Right 1	1961 066	1961 066	1961 066	1961 066	----
		Left 1	1961 067	1961 067	1961 067	1961 067	----
		Rear Right 1	1861 014	1861 014	1861 014	1861 014	----
		Left 1	1861 015	1861 015	1861 015	1861 015	----
23-51-8	COVER, Body Side Sill Front End	Right 1	----	----	----	----	*1861 270
		Left 1	----	----	----	----	*1861 271
23-51-41	BAR, Quarter Belt Side	Right 1	----	----	1878 428	1878 428	1877 462
	Sp. Cl. Cp.	Left 1	----	----	1878 429	1878 429	1877 463
	Cv. Cp., D2	Right 1	1909 474	1909 508	----	1909 510	----
		Left 1	1909 475	1909 509	----	1909 511	----
	Cv. Cp., D4	Right 1	----	1963 996	----	----	----
		Left 1	----	1963 997	----	----	----
	BAR, Side Belt	Right 1	----	----	1878 428	1878 428	----
	Sp. Cl. Cp.	Left 1	----	----	1878 429	1878 429	----
	Sub.	Right 1	1878 238	1878 238	----	1878 238	----
		Left 1	1878 239	1878 239	----	1878 239	----
	4 D., Sp. 4 D.	Right 1	----	----	----	----	1877 522
		Left 1	----	----	----	----	1877 523
	Cv. Cp.	Right 1	----	----	----	----	1877 494
		Left 1	----	----	----	----	1877 495
	BAR, Rear Belt	1	1950 584	1950 584	----	1952 273	----
	Cv. Cp.	1	----	----	1877 975	1877 975	----
	BAR, Center Belt	1	----	----	1877 975	1877 975	----
	Sp. Cl. Cp., S1	1	----	----	2093 981	2093 981	----
23-51-45	PLUG, Side Belt Bar Sealing	4	2093 981	2093 981	----	2093 981	----
	Sub.	4	2093 981	2093 981	----	2093 981	----
23-52-O SEAT SPRING							
23-52-1	SPRING PACKAGE, Seat Cushion Helper	1	*1872 552	*1872 552	*1872 552	*1872 552	*1872 552
	w/o Heavy Duty Springs	1	2160 999	2160 999	----	----	----
	w/Heavy Duty Springs	1	2160 999	2160 999	----	----	----
23-54-O TAIL GATE							
23-54-1	LOCK, Tailgate	Right 1	1961 786	1961 786	----	1961 786	----
	Sub.	Left 1	1961 787	1961 787	----	1961 787	----
23-54-3	TAILGATE	w/Electric Window Lift 1	1909 473	1909 473	----	1909 473	----
		w/Manual Window Lift 1	1909 472	1909 472	----	----	----
23-54-4	HINGE, Tailgate	w/Flat End PIN 2	*1960 182	*1960 182	----	*1960 182	----
	Sub.	w/Tapered End PIN, Right 1	2188 934	2188 934	----	2188 934	----
		Left 1	2188 935	2188 935	----	2188 935	----
23-54-6	PLATE, Tailgate Lock Striker	Right 1	1774 024	1774 024	----	1774 024	----
	Sub.	Left 1	1774 025	1774 025	----	1774 025	----
23-54-11	ORNAMENT PACKAGE, Tailgate Lift	w/Electric Window Lift 1	2196 461	2196 461	----	2196 461	----
	Sub.	NUT and WASHER 3	151 497	151 497	----	151 497	----
	ORNAMENT, Tailgate	Sub. 1	2196 148	----	----	----	----
	Sub.	CLIP 3	6000 020	----	----	----	----
	MEDALLION, Tailgate "500"	Sub. 1	----	2196 459	----	----	----
	Sub.	CLIP 3	----	6000 020	----	----	----

★ Indicates use as required.

⊠ Indicates parts not listed in any previous parts book.

* Indicates change or addition.

Printed in U.S.A.

Prices and specifications subject to change without notice.

1960 PASSENGER CAR PARTS CATALOG

BODY

CODE	REMARKS	PER CAR	PLYMOUTH	DODGE	DESOTO	CHRYSLER	IMPERIAL
23-54-O TAIL GATE - Cont'd							
23-54-11	NAME PLATE, Tailgate						
	Sub. "Plymouth"	1	2196 147	----	----	----	----
	CLIP	3	6010 174	----	----	----	----
	Sub. "Dodge"	1	----	2196 446	----	----	----
	CLIP	4	----	6000 050	----	----	----
	Sub. "Chrysler"	1	----	----	----	2196 469	----
	NUT and WASHER	4	----	----	----	6000 490	----
	Sub. "D"	2	----	2196 258	----	----	----
	Sub. "O"	1	----	2196 259	----	----	----
	Sub. "G"	1	----	2196 260	----	----	----
	Sub. "E"	1	----	2196 261	----	----	----
	CLIP	5	----	6010 174	----	----	----
	NUT and SEAL	5	----	6000 490	----	----	----
23-54-12	SCREW, Tailgate Outside Handle Base						
	Sub.	3	1960 020	1960 020	----	----	----
23-54-18	BASE, Tailgate Ornament						
	Sub.	1	1960 792	----	----	----	----
23-54-20	BUSHING, Tailgate Hinge Mounting						
	Sub. 2 1/10" lgh.	2	*1960 186	*1960 186	----	*1960 186	----
	2 2/3" lgh. Right	1	2188 836	2188 836	----	2188 836	----
	Left	1	2188 628	2188 628	----	2188 628	----
23-54-26	CLIP, Tailgate Watershield Attaching						
	Sub.	2	2086 574	2086 574	----	2086 574	----
23-54-27	SPACER, Tailgate Lock Striker						
	Sub.	★	1777 926	1777 926	----	1777 926	----
23-54-28	GUARD, Tailgate Lower Dust						
	Sub.	1	2093 494	2093 494	----	2093 494	----
23-54-31	SPRING, Tailgate Lock Lever						
	Sub.	2	1777 458	1777 458	----	1777 458	----
23-54-32	SCREW, Tailgate Hinge Attaching						
	Sub.	6	6006 056	6006 056	----	6006 056	----
23-54-53	SEAL, Tailgate Access Cover to Inner Panel						
	Sub. Foam	1	2241 219	2241 219	----	2241 219	----
23-54-59	BRACKET, Tailgate Window Down Position						
	Stop Bumper						
	Sub.	2	1878 584	1878 584	----	1878 584	----
23-54-63	PLATE, Tailgate Opening Lower Scuff						
	Sub.	1	2080 012	2080 012	----	2080 012	----
	MOULDING, Tailgate Opening Lower Sill						
	2 D. Sub., 4 D. Sub., P1L, P2L, P1M, P2M						
	D3, D4 Right	1	2080 010	2080 010	----	----	----
	Left	1	2080 011	2080 011	----	----	----
23-54-69	SCREW and WASHER, Tailgate Lock Striker						
	Plate						
	Sub.	★	6022 147	6022 147	----	6022 147	----
23-54-72	REGULATOR or PLATE and ARM, Tailgate						
	Window						
	Sub. Manual	1	1878 450	1878 450	----	----	----
	Electric	1	1961 367	1961 367	----	1961 367	----
23-54-73	HANDLE, Tailgate Manual Window Regulator						
	Sub.	1	1960 493	1960 493	----	----	----
23-54-74	SPRING, Tailgate Window Regulator						
	Sub.	1	1779 645	1779 645	----	1779 645	----
23-54-75	FLAP, Tailgate Handle						
	Sub.	1	2080 673	2080 673	----	2080 673	----
23-54-79	RETAINER, Tailgate Manual Window Regulator						
	Handle Knob						
	Sub.	1	1775 164	1775 164	----	----	----
23-54-90	PIN, Tailgate Window Regulator Arm Roller						
	Sub.	2	1960 969	1960 969	----	1960 969	----
23-54-94	SCREW and WASHER, Tailgate Window						
	Regulator to Mounting Plate						
	Sub.	4	6006 082	6006 082	----	6006 082	----

★ Indicates use as required.

⊠ Indicates parts not listed in any previous parts book.
Dec. 9, 1960 Supersedes April 20, 1960.

Printed in U.S.A.
Prices and specifications subject to change without notice.
* Indicates change or addition.

CODE	REMARKS	PER CAR	PLYMOUTH	DODGE	DESOTO	CHRYSLER	IMPERIAL
23-54-0 TAILGATE - Cont'd							
23-54-96	CLIP, Tailgate Ornament or Medallion Sub.	3	6000 020	6000 020	----	----	----
	CLIP, Tailgate Name Letters Sub.	10	----	6010 174	----	----	----
23-54-103	BUMPER, Tailgate Window Down Position Stop Sub.	2	1381 435	1381 435	----	1381 435	----
23-54-137	CAM, Tailgate Hinge Torsion Bar Sub.	1	1960 197	1960 197	----	1960 197	----
23-54-140	BAR, Tailgate Hinge Torsion Sub.	1	1960 194	1960 194	----	1960 194	----
23-54-142	BEARING, Tailgate Hinge Torsion Bar Sub.	1	1960 187	1960 187	----	1960 187	----
23-54-144	CLAMP, Tailgate Hinge Torsion Bar Sub.	1	1960 195	1960 195	----	1960 195	----
23-54-145	ROLLER, Tailgate Hinge Torsion Bar Sub.	1	1960 196	1960 196	----	1960 196	----
23-54-146	RETAINER, Tailgate Down Position Bumper Sub. Pkg.	2	2196 467	2196 467	----	2196 467	----
	NUT and WASHER	4	6010 048	6010 048	----	6010 048	----
23-54-147	BUMPER, Tailgate Down Position Sub.	2	1877 931	1877 931	----	1877 931	----
23-54-148	NUT and WASHER, Tailgate Down Position Bumper Retainer Attaching Sub.	4	6010 048	6010 048	----	6010 048	----
23-54-150	COVER, Tailgate Inside, Steel Sub.	1	1877 855	1877 855	----	1877 855	----
23-54-152	SHAFT or COUPLING, Tailgate Electric Window Lift Motor to Mechanism Sub.	1	1778 955	1778 955	----	1778 955	----
23-54-154	SCREW and WASHER, Tailgate Electric Window Lift Motor Mounting Sub.	2	6006 070	6006 070	----	6006 070	----
23-54-156	REPAIR PACKAGE, Tailgate Electric Window Lift Mechanism Sub.	1	B2275 141	B2275 141	----	B2275 141	----
23-54-158	BRUSH and SPRING PACKAGE, Tailgate Electric Window Lift Motor Sub.	1	1688 692	1688 692	----	1688 692	----
23-54-159	RELAY, Tailgate Electric Window Lift Switch Lock Sub., used w/Child Guard	1	----	B2197 164	----	----	----
23-54-160	MOTOR, Tailgate Electric Window Lift Sub.	1	2093 964	2093 964	----	2093 964	----
23-54-163	LINK, Tailgate Electric Window Lift Lock Switch Sub.	1	1972 496	1972 496	----	----	----
	Switch End	1	1972 497	1972 497	----	----	----
	Lock End	1	1972 497	1972 497	----	----	----
23-54-164	TURNBUCKLE, Tailgate Electric Window Lift Lock Switch Links Sub.	1	1819 190	1819 190	----	1819 190	----
23-54-165	MECHANISM, Tailgate Electric Window Lift Sub.	1	2094 012	2094 012	----	2094 012	----
23-54-167	SWITCH, Tailgate Electric Window Lift Sub. On Instrument Panel Third Seat Passengers, On Head Liner, Includes BEZEL Less Bezel	1	1972 316	2096 373	----	2097 045	----
	Lock, in Tailgate	1	2097 626	2097 626	----	2097 626	----
	Limit, on Tailgate	1	2097 625	2097 625	----	2097 625	----
		1	1887 041	1887 041	----	1887 041	----
		1	1887 946	1887 946	----	1887 946	----
23-54-168	LEVER, Tailgate Electric Window Lift Lock Switch Sub.	1	1819 182	1819 182	----	1819 182	----

★ Indicates use as required.

☐ Indicates parts not listed in any previous parts book.

* Indicates change or addition.

Printed in U.S.A.

Prices and specifications subject to change without notice.

1960 PASSENGER CAR PARTS CATALOG

BODY

CODE	REMARKS	PER CAR	PLYMOUTH	DODGE	DESOTO	CHRYSLER	IMPERIAL
23-54-O TAIL GATE -Cont'd							
23-54-169	KNOB, Tailgate Electric Window Lift Instrument Panel Switch Sub., D3, D4 D1, D2	1 1	1887 591 ----	2096 309 1887 860	---- ----	2197 075 ----	---- ----
23-54-170	BEZEL, Tailgate Electric Window Lift Instrument Panel Switch Sub.	1	----	1887 789	----	----	----
23-54-171	NUT, Tailgate Electric Window Lift Instrument Panel Switch Mounting Sub. NUT, Tailgate Electric Window Lift Lock Switch Mounting Sub.	1 1	1887 603	1972 548	----	----	----
23-54-172	CLIP, Tailgate Electric Window Lift Lock Switch Link Mounting Sub. Lock End Switch End SPRING, Tailgate Electric Window Lift Third Seat Passengers Switch to Headliner Retaining Sub.	1 1 4	1652 092 6008 145 1769 327	1652 092 6008 145 1769 327	---- ---- ----	1652 092 6008 145 1769 327	---- ---- ----
23-54-173	CONNECTOR, Electric Tailgate Window Lift Switch Single Sub.	1	2096 905	2096 905	----	2096 905	----
23-54-176	CIRCUIT BREAKER, Tailgate Electric Window Lift Sub. 30 amp.	1	1689 022	1689 022	----	1689 022	----
23-54-177	CLIP, Tailgate Electric Window Lift Circuit Breaker Mounting Sub.	1	6015 159	6015 159	----	6015 159	----
23-54-180	HANDLE, Tailgate Lock Remote Control Sub.	1	1902 406	1902 406	----	1902 406	----
23-54-184	ROD, Tailgate Lock Remote Control Handle to Lock Sub.	1	1961 125	1961 125	----	1961 125	----
23-54-186	SPRING, Tailgate Lock Remote Control Handle Anti-Rattle Sub.	1	1902 409	1902 409	----	1902 409	----
23-54-190	PIN, Tailgate Lock Remote Control Handle Attaching Sub.	1	1902 410	1902 410	----	1902 410	----
23-54-193	BEARING, Tailgate Lock Remote Control Handle to Lock Rod Sub.	2	1961 118	1961 118	----	1961 118	----
23-54-194	RETAINER, Tailgate Lock Remote Control Handle to Rod Bearing Sub.	2	1961 119	1961 119	----	1961 119	----
23-54-195	SCREW, Tailgate Handle to Latch Pin Sub.	3	1902 297	1902 297	----	1902 297	----
23-54-200	ARMATURE, Tailgate Electric Window Lift Motor Sub.	1	1818 900	1818 900	----	1818 900	----
23-54-206	HEAD, Tailgate Electric Window Lift Motor Commutator End Sub.	1	1818 866	1818 866	----	1818 866	----
23-54-212	COIL, Tailgate Electric Window Lift Motor Field Sub.	1	1818 864	1818 864	----	1818 864	----

★ Indicates use as required.

□ Indicates parts not listed in any previous parts book.

Dec. 9, 1960 Supersedes April 20, 1960.

Printed in U.S.A.
Prices and specifications subject to change without notice.

* Indicates change or addition.

CODE	REMARKS	PER CAR	PLYMOUTH	DODGE	DESOTO	CHRYSLER	IMPERIAL
23-58-0 FOLDING TOP							
23-58-3	TOP, Folding Cv. Cp.	1	1952 312	1952 312	----	1952 313	2094 745
NOTE:	Above assemblies less lift Mechanism and Trim.						
23-58-66	SCREW, Folding Top Rear Bow to Wheelhouse Bracket Tension Cable Cv. Cp.	2	2165 664	2165 664	----	2165 664	----
23-58-67	BOLT, Folding Top Rear Bow to Wheelhouse Bracket Tension Cable Cv. Cp.	2	6022 169	6022 169	----	6022 169	----
23-58-67	BRACKET, Folding Top Quarter Belt Bar Bow Tension Cable Cv. Cp.	2	1954 604	1954 604	----	1954 604	----
23-58-75	BOW, Folding Top Cv. Cp.	No. 1 No. 2 Rear	1964 078 1964 073 1952 195	1964 078 1964 073 1952 195	----	1964 078 1964 073 1952 195	1691 415 1691 397 1691 400
23-58-76	LINK, Folding Top Rear Bow Cv. Cp.	Right Left	1950 500 1950 501	1950 500 1950 501	----	1950 502 1950 503	----
23-58-76	EXTENSION, Folding Top Rear Bow Cv. Cp.	Right Left	---- ----	---- ----	----	---- ----	1691 902 1691 903
23-58-78	PLATE, Folding Top Number One Bow Bracket to Link Adjusting Cv. Cp.	2	1909 914	1909 914	----	1909 914	----
23-58-85	BRACKET, Folding Top Header Rear Bow Down Stop Cv. Cp., D2	2	----	2165 669	----	----	----
23-58-195	TERMINAL BLOCK, Folding Top Lift Wiring Cv. Cp. On Floor Pan	1	----	913 297	----	913 297	913 297
23-58-200	CYLINDER, Folding Top Lift Cv. Cp.	2 Right Left	1952 938 ---- ----	1952 938 ---- ----	----	1952 938 ---- ----	---- 1770 553 1770 552
23-58-208	BRACKET, Folding Top Lift Cylinder Floor Pan Mounting Cv. Cp.	2	1952 939	1952 939	----	1952 939	1861 392
23-58-211	YOKE, Folding Top Cylinder to Power Link Cv. Cp.	2	*1249 525	*1249 525	----	*1249 525	----
23-58-220	HEADER, Folding Top Cv. Cp.	1	2166 338	2166 338	----	2166 338	1751 094
23-58-224	RETAINER, Folding Top Trim, on Belt Bar Cv. Cp.	Right Left	---- ----	---- ----	----	1963 552 1963 553	1877 746 1877 747
23-58-225	BRACKET, Folding Top Trim Fastener, on Front Side Rail Cv. Cp.	Right Left	---- ----	---- ----	----	---- ----	1810 588 1810 589
23-58-227	MECHANISM, Folding Top Header Locking Cv. Cp.	1	2166 049	2166 049	----	2166 049	----
23-58-228	DOWEL, Folding Top Header Cv. Cp.	2	1909 466	1909 466	----	1909 466	6006 235
23-58-229	RETAINER, Folding Top Header Dowel Lock Nut Cv. Cp.	2	----	----	----	----	1691 911
23-58-232	COVER, Folding Top Header Lock Mechanism Access Hole Cv. Cp. 6 7/16" Long	1	----	----	----	----	1750 777
23-58-232	COVER, Folding Top Header Lock Access Hole Cv. Cp. 7 3/8" Long, Right	1	----	----	----	----	1750 854
23-58-232	COVER, Folding Top Header Lock Access Hole Cv. Cp. 7 3/8" Long, Left	1	----	----	----	----	1750 855

★ Indicates use as required.

□ Indicates parts not listed in any previous parts book.

* Indicates change or addition.

1960 PASSENGER CAR PARTS CATALOG

BODY

CODE	REMARKS	PER CAR	PLYMOUTH	DODGE	DESOTO	CHRYSLER	IMPERIAL
23-58-0 FOLDING TOP - Cont'd							
23-58-234	CLIP, Folding Top Header Lock Torsion Bar to Link Cv. Cp.	1	----	----	----	----	6006 221
23-58-237	SEAL, Folding Top Header Dowel Cv. Cp.	2	1964 981	1964 981	----	1964 981	----
	SEAL, Windshield Header Cv. Cp.	1	*2094 559	*2094 559	----	*2094 559	----
23-58-240	PANEL, Folding Top Header Outside Finish Cv. Cp.	1	1954 020	1954 020	----	1954 020	1954 020
	MOULDING, Folding Top Header Outside Finish Cv. Cp.	Pkg. 1	----	----	----	----	2196 483
	SCREW	11	----	----	----	----	274 110
	SCREW	2	----	----	----	----	162 289
23-58-242	CLIP, Folding Top Header Outside Finish Panel Cv. Cp.	5	6000 680	6000 680	----	6000 680	----
	End	2	6000 681	6000 681	----	6000 681	----
23-58-243	HANDLE, Folding Top Header Lock Cv. Cp.	1	----	----	----	----	1751 156
23-58-245	PIN, Folding Top Header Lock Handle to Torsion Bar Link Cv. Cp.	1	----	----	----	----	6006 222
23-58-248	RETAINER, Folding Top Header Lock Handle to Escutcheon Pin Cv. Cp.	2	----	----	----	----	1750 724
23-58-253	ESCUTCHEON, Folding Top Header Lock Handle Cv. Cp.	1	----	----	----	----	1751 173
23-58-257	LINK, Folding Top Header Lock Handle to Torsion Bar Cv. Cp.	1	----	----	----	----	1750 619
23-58-265	CATCH, Folding Top Header Locking Latch Cv. Cp.	2	1964 895	1964 895	----	1964 895	----
	CATCH, Folding Top Header Lock Safety Cv. Cp.	1	----	----	----	----	1751 264
23-58-266	SPRING, Folding Top Header Lock Safety Catch to Handle	1	----	----	----	----	1751 262
23-58-269	LINKAGE, Folding Top Side Rail Cv. Cp.	Right 1	1964 076	1964 076	----	1964 074	1751 206
	Left	1	1964 077	1964 077	----	1964 075	1751 207
23-58-327	LINK, Folding Top Power Cv. Cp.	2	1952 559	1952 559	----	----	----
	Right	1	----	----	----	1952 730	----
	Left	1	----	----	----	1952 731	----
23-58-333	LINK, Folding Top Power Guide Cv. Cp.	2	1952 602	1952 602	----	1952 557	----
	Inner, Includes Power LINK	2	----	----	----	----	1751 210
	Outer	2	----	----	----	----	1750 400
23-58-335	TAPPING PLATE, Folding Top Power Guide Link Support Cv. Cp.	2	6000 388	6000 388	----	6000 388	----
	TAPPING PLATE, Folding Top Main Control Prop Support Cv. Cp.	2	6000 388	6000 388	----	6000 388	----
23-58-336	SUPPORT, Folding Top Power Guide Link Cv. Cp.	2	1708 914	1708 914	----	1708 914	----
	SUPPORT, Folding Top Main Control Prop Cv. Cp.	2	1708 914	1708 914	----	1708 914	----
23-58-357	MOTOR, Folding Top Lift Cv. Cp.	1	2094 107	2094 107	----	2094 107	2094 107
	Less Pump Includes PUMP	1	1648 340	1648 340	----	1648 340	1648 340
23-58-364	PLUG, Folding Top Well Drain Valve Cv. Cp.	1	1977 449	1977 449	----	1977 449	1977 449

★ Indicates use as required.

☐ Indicates parts not listed in any previous parts book.

Dec. 9, 1960 Supersedes April 20, 1960.

Printed in U.S.A.
Prices and specifications subject to change without notice.

Page 23-102

* Indicates change or addition.

CODE	REMARKS	PER CAR	PLYMOUTH	DODGE	DESOTO	CHRYSLER	IMPERIAL
23-58-0 FOLDING TOP - Cont'd							
23-58-365	RETAINER, Folding Top Well Drain Plug Cv. Cp.	1	1977 448	1977 448	----	1977 448	1977 448
23-58-375	"O" RING, Folding Top Lift Motor Pump Drive Shaft Cv. Cp.	1	1641 590	1641 590	----	1641 590	1641 590
23-58-379	CIRCUIT BREAKER, Folding Top Lift Cv. Cp. 30 amp.	1	1689 022	1689 022	----	1689 022	1689 022
23-58-381	ROTOR PACKAGE, Folding Top Lift Pump Cv. Cp.	1	-----	-----	-----	-----	1641 650
23-58-393	SUPPORT, Folding Top Lift Motor and Pump Floor Pan Cv. Cp.	1	-----	-----	-----	-----	1878 112
23-58-394	PILLAR or RAIL, Folding Top Folding Cv. Cp.	Right Left	1884 584 1884 585	1884 584 1884 585	----	1884 586 1884 587	1691 946 1691 947
23-58-395	PLUG, Folding Top Lift Pump Reservoir Filler Cv. Cp. Includes "O" RING	1	1641 579	1641 579	----	1641 579	1641 579
23-58-396	BRACKET, Folding Top Lift Motor Mounting Cv. Cp.	1	1641 578	1641 578	----	1641 578	1641 578
23-58-430	PLATE, Folding Top Lift Pump Cover Cv. Cp. Includes Valve Rocker ARM	1	1641 592	1641 592	----	1641 592	1641 592
23-58-469	PLATE, Folding Top Lift Pump End Cv. Cp. Includes BUSHING	1	1641 586	1641 586	----	1641 586	1641 586
23-58-469	PROP, Folding Top Main Control Cv. Cp.	Right Left	1884 580 1884 581	1884 580 1884 581	----	1884 582 1884 583	----- -----
23-58-469	LINK, Folding Top Main Control Cv. Cp. Includes Adjusting PLATE,	Right Left	----- -----	----- -----	----- -----	----- -----	1751 208 1751 209
23-58-472	BRACKET, Folding Top Folding Rail Pivot Cv. Cp.	Right Left	----- -----	----- -----	----- -----	----- -----	1691 948 1691 949
23-58-473	SUPPORT, Folding Top Folding Pillar to Body Cv. Cp.	Right Left	1884 608 1884 609	1884 608 1884 609	----	1884 608 1884 609	----- -----
23-58-473	BRACKET, Folding Top Folding Rail Pivot Bracket to Body Mounting Support Cv. Cp.	Right Left	----- -----	----- -----	----- -----	----- -----	1750 406 1750 407
23-58-475	PLATE, Folding Top Main Control Prop Support Plate Adjustment Cv. Cp.	2	1954 824	1954 824	----	1954 824	-----
23-58-476	BRACE, Folding Top Main Control Prop Body Cv. Cp.	Right Left	1884 504 1884 505	1884 506 1884 507	----	1884 508 1884 509	----- -----
23-58-476	SUPPORT, Folding Top Main Control Link and Pivot Bracket Mounting Bracket Body Cv. Cp.	Right Left	----- -----	----- -----	----- -----	----- -----	1961 088 1961 089
23-58-480	REINFORCEMENT, Folding Top Folding Rail Pivot Bracket Mounting Bracket to Body Mounting Cv. Cp.	2	-----	-----	-----	-----	*1751 810
23-58-480	REINFORCEMENT, Folding Top Main Control Link Adjustment Plate Body Cv. Cp.	Right Left	----- -----	----- -----	----- -----	----- -----	1751 806 1751 807
23-58-486	RAIL, Folding Top Side Cv. Cp.	Front Right Left Rear Right Left	1884 588 1884 589 1884 590 1884 591	1884 588 1884 589 1884 590 1884 591	----	1884 592 1884 593 1884 594 1884 595	2094 466 2094 467 2094 472 2094 473

★ Indicates use as required.

☐ Indicates parts not listed in any previous parts book.

* Indicates change or addition.

1960 PASSENGER CAR PARTS CATALOG

BODY

CODE	REMARKS	PER CAR	PLYMOUTH	DODGE	DESOTO	CHRYSLER	IMPERIAL
23-58-0 FOLDING TOP - Cont'd							
23-58-487	BUSHING, Folding Top Folding Rail to Body Pivot Bracket Pin Cv. Cp.	2	----	----	----	----	1810 440
	BUSHING, Folding Top Side Rail Link to Rear Rail Pin Cv. Cp.	2	----	----	----	----	1750 647
23-58-497	CAP, Folding Top Front Side Rail to Header Joint Cv. Cp.	2	1950 486	1950 486	----	1950 486	----
23-58-532	SWITCH, Folding Top Lift Cv. Cp.	1	1972 316	2096 373	----	1972 318	1972 319
23-58-533	NUT, Folding Top Lift Switch Mounting Cv. Cp.	1	1887 603	1972 548	----	1971 521	----
23-58-534	KNOB, Folding Top Lift Switch Cv. Cp., D2	1	1887 591	1887 860	----	2197 075	1887 935
	D4	1	----	2096 309	----	----	----
23-58-535	HOUSING, Folding Top Lift Switch Cv. Cp.	1	----	----	----	1972 146	----
23-58-543	BEZEL, Folding Top Lift Switch Cv. Cp.	1	----	2197 501	----	1972 489	----
23-58-555	HOSE, Folding Top Lift Pump to Cylinder Cv. Cp.	1	1964 402	1964 402	----	1964 402	1964 402
	Upper	1	1964 402	1964 402	----	1964 402	2094 119
	Lower	1	1964 402	1964 402	----	1964 402	2094 119
23-58-569	WEATHERSTRIP, Folding Top Header Cv. Cp.	1	1950 842	1950 842	----	1950 842	----
	Inner	1	----	----	----	----	1751 733
	Outer	1	----	----	----	----	*1860 995
	Upper Corner Moulding, Right	1	----	----	----	----	1861 334
	Left	1	----	----	----	----	1861 335
23-58-572	WEATHERSTRIP, Folding Top Side Rail Cv. Cp.	1	1950 844	1950 844	----	1950 846	1810 002
	Front Right	1	1950 844	1950 844	----	1950 846	1810 002
	Left	1	1950 845	1950 845	----	1950 847	1810 003
	Rear Right	1	1950 848	1950 848	----	1950 850	1810 004
	Left	1	1950 849	1950 849	----	1950 851	1810 005
23-58-573	RETAINER, Folding Top Side Rail Weather- strip Cv. Cp.	1	1954 942	1954 942	----	1954 944	----
	Front Right	1	1954 942	1954 942	----	1954 944	----
	Left	1	1954 942	1954 942	----	1954 944	----
	Rear Right	1	1954 938	1954 938	----	1954 940	----
	Left	1	1954 939	1954 939	----	1954 941	----
23-58-590	WEATHERSTRIP, Folding Top Folding Pillar or Rail Cv. Cp.	1	1950 852	1950 852	----	1950 854	1810 006
	Right	1	1950 852	1950 852	----	1950 854	1810 006
	Left	1	1950 853	1950 853	----	1950 855	1810 007
23-58-591	RETAINER, Folding Top Folding Pillar Weatherstrip Cv. Cp.	1	1954 934	1954 934	----	1954 936	----
	Right	1	1954 934	1954 934	----	1954 936	----
	Left	1	1954 935	1954 935	----	1954 937	----
23-58-603	SCREW, Folding Top Side Rear Rail Cv. Cp.	2	1964 260	1964 260	----	1964 260	----
	BOLT, Folding Top Power Guide Link Cv. Cp.	2	1954 765	1954 765	----	1954 765	----
	BOLT, Folding Top Main Control Prop Cv. Cp.	2	1954 765	1954 765	----	1954 765	----
	SCREW, Folding Top Header Lock Torsion Bar Adjusting Cv. Cp.	2	----	----	----	----	1750 726
	BOLT, Folding Top Control Link Adjusting Plate Cv. Cp.	2	----	----	----	----	6006 224

★ Indicates use as required.

⊠ Indicates parts not listed in any previous parts book.
Dec. 9, 1960 Supersedes April 20, 1960.

Printed in U.S.A.

Prices and specifications subject to change without notice.

* Indicates change or addition.

CODE	REMARKS	PER CAR	PLYMOUTH	DODGE	DESOTO	CHRYSLER	IMPERIAL
23-58-O FOLDING TOP - Cont'd							
23-58-605	SPACER or WASHER, Folding Top Cv. Cp.						
	O.D. I.D. THICKNESS MATERIAL						
	7/8" 7/16" 15/64" Rubber	4	1249 332	1249 332	----	1249 332	----
	1" 17/32" 1/16" Fibre	6	1706 470	1706 470	----	1706 470	----
	1" 19/32" 1/8" Fibre	4	1952 983	1952 983	----	1952 983	----
	5/8" 25/64" 1/16" Steel	2	6000 320	6000 320	----	6000 320	----
	7/8" 7/16" 7/64" Leather	4	----	----	----	----	6000 141
	13/16" 3/8" 13/64" Plastic	2	6006 204	6006 204	----	6006 204	6006 204
	X-WASHER, Folding Top Cv. Cp.	2	----	----	----	----	6006 052
23-58-606	SPRING WASHER, Folding Top Cv. Cp.						
	7/8" O.D. x 19/32" I.D.	★	6000 098	6000 098	----	6000 098	----
	3/4" O.D. x 25/64" I.D.	★	----	----	----	----	6006 216
23-58-607	PIN, Folding Top Cv. Cp.						
	No. '1 Bow Bracket	2	1950 897	1950 897	----	1950 897	----
	No. 1 Bow Bracket to Front Side Rail	2	1952 315	1952 315	----	1952 315	----
	No. 1 Bow Bracket to Rear Side Rail	2	1952 315	1952 315	----	1952 315	----
	Shoulder Prop to Main Control	2	1952 315	1952 315	----	1952 315	----
	Front and Rear Side Rail Connector	2	1952 315	1952 315	----	1952 315	----
	Rear Side Rail Hinge to Folding Pillar	2	1952 779	1952 779	----	1952 779	----
	Rear Bow	2	1952 984	1952 984	----	1952 984	----
	Front to Rear Side Rail	2	6000 319	6000 319	----	6000 319	----
	Lift Cylinder Mounting Bracket to Folding Pillar	2	1952 936	1952 936	----	1952 936	----
	Control Link to Front Rail	2	⊠1952 482	⊠1952 482	----	⊠1952 482	----
	No. 2 Bow to Rear Side Rail	2	----	----	----	----	6006 205
	Rear Control Link to Center Side Rail	2	----	----	----	----	6006 230
	Lift Cylinder Mounting Bracket	2	----	----	----	----	6006 093
	Control Link to Center Rail	2	----	----	----	----	6006 223
	Rear Side Rail to Body Bracket	2	----	----	----	----	6006 226
	Power Link to Rear Rail	2	----	----	----	----	6006 227
	Power Guide Link to Body Bracket	2	----	----	----	----	6006 228
	Front to Center Side Rail Pivot	2	----	----	----	----	6006 229
	Center to Rear Side Rail Pivot	2	----	----	----	----	6006 231
	Rear Bow to Rear Rail	2	----	----	----	----	6006 237
23-59-O DRAIN TROUGH AND MOULDING							
23-59-37	REINFORCEMENT, Deck Opening Side Drain Trough						
	Right	1	----	----	----	----	1877 472
	Left	1	----	----	----	----	1877 473
23-59-40	REINFORCEMENT, Quarter Panel Drain Trough						
	4 D., Sp. 4 D., Sp. Cl. Cp., Cv. Cp.						
	Right	1	----	----	1878 758	1878 758	----
	Left	1	----	----	1878 759	1878 759	----
23-59-56	TROUGH, Quarter Roof Side Drain Sp. Cl. Cp.						
	Right	1	*1952 682	*1952 682	----	----	----
	Left	1	1952 683	1952 683	----	----	----
	TROUGH, Roof Rear Drain Sub.	1	2094 134	2094 134	----	2094 134	----
23-59-57	CAP, Roof Side Drain Trough Moulding D3-L, D4-L						
	Front Right	1	----	1964 226	----	----	----
	Left	1	----	1964 227	----	----	----
23-59-61	MOULDING or COVER, Roof Side Drain Trough						
	4 D., Cl. Sed., D1, D2						
	Right	1	1909 624	1909 636	1909 636	2093 648	1690 804
	Left	1	1909 625	1909 637	1909 637	2093 649	1690 805
	4 D., Cl. Sed., D3, D4						
	Right	1	----	1964 224	----	----	----
	Left	1	----	1964 225	----	----	----
	Sp. 4 D., Sp. 4 D. Sub., D1, D2, C1, C2						
	Right	1	----	1909 636	1909 636	2093 648	1750 104
	Left	1	----	1909 637	1909 637	2093 649	1750 105
	Sp. 4 D., Sp. 4 D. Sub., C3						
	Right	1	----	----	----	*1909 636	----
	Left	1	----	----	----	1909 637	----
	Sp. Cl. Cp., P1M, P2M						
	Right	1	1909 626	1909 626	2093 174	2093 174	1750 102
	Left	1	1909 627	1909 627	2093 175	2093 175	1750 103

★ Indicates use as required.

⊠ Indicates parts not listed in any previous parts book.

* Indicates change or addition.

CODE	REMARKS	PER CAR	PLYMOUTH	DODGE	DESOTO	CHRYSLER	IMPERIAL
23-59-O DRAIN TROUGH AND MOULDING - Cont'd							
23-59-61	MOULDING OR COVER - Cont'd						
	4 D. Sub., 2 D. Sub., D1	Right	1	2094 122	1909 636	----	----
		Left	1	2094 123	1909 637	----	----
	4 D. Sub., D3M, D4M	Right	1	----	2094 122	----	----
		Left	1	----	2094 123	----	----
23-61-O COWL VENT OR AIR INTAKE							
23-61-39	EXTENSION, Dash Panel Cowl Air Intake						
	Water Deflector Panel		1	----	----	----	*1242 974
	DEFLECTOR, Dash Panel Cowl Air Intake						
	Water		1	----	----	----	*1810 088
23-61-98	SCREEN, Cowl Vent	Right	1	----	----	----	*1751 008
		Left	1	----	----	----	1751 009
23-61-99	CLIP, Cowl Vent Grille Attaching		6	----	----	----	*6006 261
23-61-103	GRILLE, Cowl Ventilator	Right	1	----	----	----	1878 644
		Left	1	----	----	----	1878 645
23-61-104	CAP, Cowl Vent Grille		1	----	----	----	*1861 345
23-61-116	PANEL, Cowl Top Fresh Air Opening Insert						
	Steel		1	2165 691	2165 691	2165 691	2165 691
	Aluminum		1	1909 441	1909 441	1909 441	1909 441
23-61-119	PLUG, Cowl Fresh Air Opening Insert Panel		2	*1963 200	*1963 200	*1963 200	*1963 200
23-63-O WEATHERSTRIP							
23-63-14	WEATHERSTRIP, Front Door Window Belt						
	Inner						
	4 D., 4 D. Sub., C1, C2		2	1883 500	1883 500	1883 500	1883 500
	C3	Right	1	----	----	----	2085 710
		Left	1	----	----	----	2085 711
	4 D.	Right	1	----	----	----	2085 764
		Left	1	----	----	----	2085 765
	Sp. 4 D., Sp. 4 D. Sub., C1, C2	Right	1	1952 828	1952 828	1952 828	1952 828
		Left	1	1952 829	1952 829	1952 829	1952 829
	C3	Right	1	----	----	----	2085 712
		Left	1	----	----	----	2085 713
23-63-14	WEATHERSTRIP, Rear Door Window Belt						
	Inner						
	4 D., D3, D4, C1, C2	Right	1	1954 680	1954 680	1883 512	1883 512
		Left	1	1954 681	1954 681	1883 513	1883 513
	D1, D2, C3	Right	1	----	1883 512	----	2085 482
		Left	1	----	1883 513	----	2085 482
	Sp. 4 D., Sp. 4 D. Sub., D1, D2, D4, S1, C1, C2		2	1883 518	1883 518	1883 518	1883 518
	Sp. 4 D., Sp. 4 D. Sub., C3		2	----	----	----	2085 482
	WEATHERSTRIP, Door Window Belt Inner						
	Sp. C1. Cp, Cv. Cp., C1, C2	Right	1	1952 828	1952 828	1952 828	1952 828
		Left	1	1952 829	1952 829	1952 829	1952 829
	C3	Right	1	----	----	----	2085 722
		Left	1	----	----	----	2085 723
	C1. Sed., 2 D. Sub.		2	1952 826	1952 826	----	----
23-63-15	WEATHERSTRIP, Front Door Window Belt						
	Outer						
	4 D., 4 D. Sub., C1		2	1883 500	1883 500	1883 500	1883 500
	C2, C3		2	----	----	----	1954 775
	4 D.	Right	1	----	----	----	2093 722
		Left	1	----	----	----	2093 723
	Sp. 4 D., Sp. 4 D. Sub.	Right	1	1952 828	1952 828	1952 828	1952 828
		Left	1	1952 829	1952 829	1952 829	1952 829
	WEATHERSTRIP, Rear Door Window Belt						
	Outer						
	4 D., D1, D2, C1	Right	1	1954 680	1883 512	1883 512	1883 512
		Left	1	1954 681	1883 513	1883 513	1883 513
	4 D., D3, D4, C2, C3	Right	1	----	1954 680	----	1954 776
		Left	1	----	1954 681	----	1954 777

★ Indicates use as required.

☐ Indicates parts not listed in any previous parts book.
Dec. 9, 1960 Supersedes April 20, 1960.

CODE	REMARKS	PER CAR	PLYMOUTH	DODGE	DESOTO	CHRYSLER	IMPERIAL
23-63-O WEATHERSTRIP - Cont'd							
23-63-15	WEATHERSTRIP - Cont'd						
	Sp. 4 D., D1, D2	Right	1 1954 694	1883 514	1883 514	1883 514	1751 724
		Left	1 1954 695	1883 515	1883 515	1883 515	1751 725
	Sp. 4 D., D3, D4	Right	1 ----	1954 694	----	----	----
		Left	1 ----	1954 695	----	----	----
	4 D.Sub.	Right	1 1883 512	1883 512	----	----	----
		Left	1 1883 513	1883 513	----	----	----
	Sp. 4 D.Sub.	Right	1 1883 514	1883 514	----	1883 514	----
		Left	1 1883 515	1883 515	----	1883 515	----
	WEATHERSTRIP, Door Window Belt Outer						
	Sp.Cl.Cp., Cv.Cp.	Right	1 1952 828	1952 828	1952 828	1952 828	1751 708
		Left	1 1952 829	1952 829	1952 829	1952 829	1751 709
	Cl.Sed., 2 D.Sub.		2 1952 850	1952 850	----	----	----
23-63-16	CLIP, Door Window Belt Outer Weatherstrip		★ 1775 089	1775 089	----	1775 089	6006 104
23-63-20	WEATHERSTRIP, Quarter Window Belt Inner						
	Sp.Cl.Cp., C1, C2	Right	1 1909 458	1909 458	2161 350	2161 350	----
		Left	1 1909 459	1909 459	2161 351	2161 351	----
	Sp.Cl.Cp., Cv.Cp., C3		2 ----	----	----	2085 482	1772 798
	Cv.Cp., C1		2 1883 518	1883 518	----	1883 518	----
	Cl. Sed., 2 D. Sub.		2 1909 456	1909 456	----	----	----
23-63-21	WEATHERSTRIP, Quarter Window Belt Outer						
	Cv. Cp.		2 1954 712	1954 712	2093 546	2093 546	----
	Cv. Cp.	Right	1 ----	----	----	----	2094 648
		Left	1 ----	----	----	----	2094 649
	Sp. Cl. Cp.	Right	1 2093 546	2093 546	2093 546	2093 546	2094 648
		Left	1 2093 547	2093 547	2093 547	2093 547	2094 649
	2 D. Sub.		2 1954 724	----	----	----	----
	Cl.Sed.		2 1909 456	1909 456	----	----	----
23-63-22	CLIP, Quarter Window Belt Weatherstrip						
	Sp.Cl.Cp., Cv.Cp., Cl.Sed., 2 D.Sub. Outer	★	1775 089	1775 089	1775 089	1775 089	6006 104
	Cl.Sed., 2 D.Sub. Inner	12	6000 804	6000 804	----	----	----
23-63-33	WEATHERSTRIP, Door						
	4 D.	Front Right	1 1883 504	1883 504	1883 504	1883 504	2093 866
		Left	1 1883 504	1883 504	1883 504	1883 504	2093 867
	4 D., D1, D2	Rear Right	1 1954 826	1883 520	1883 520	1883 520	2093 246
		Left	1 1954 826	1883 520	1883 520	1883 520	2093 247
	4 D., D3, D4	Rear Right	1 ----	1954 826	----	----	----
		Left	1 ----	1954 826	----	----	----
	4 D.	Bottom, Front Right	1 ----	----	----	----	1751 742
		Left	1 ----	----	----	----	1751 743
		Bottom, Rear Right	1 ----	----	----	----	1751 774
		Left	1 ----	----	----	----	1751 775
	Sp. 4 D.	Front Right	1 2165 304	2165 304	2165 304	2165 304	----
		Left	1 2165 305	2165 305	2165 305	2165 305	----
	Sp.4 D., D1, D2	Rear Right	1 2165 486	2165 488	2165 488	2165 488	----
		Left	1 2165 487	2165 489	2165 489	2165 489	----
	Sp. 4 D., D3, D4	Rear Right	1 ----	2165 486	----	----	----
		Left	1 ----	2165 487	----	----	----
	Sp. 4 D.	Hinge Pillar, Front Right	1 ----	----	----	----	1810 704
		Left	1 ----	----	----	----	1810 705
		Lock Pillar, Front Right	1 ----	----	----	----	1751 620
		Left	1 ----	----	----	----	1751 621
		Bottom, Front Right	1 ----	----	----	----	1751 742
		Left	1 ----	----	----	----	1751 743
		Hinge Pillar, Rear Right	1 ----	----	----	----	1751 618
		Left	1 ----	----	----	----	1751 619
		Lock Pillar, on Door, Rear Right	1 ----	----	----	----	1751 654
		Left	1 ----	----	----	----	1751 655
		Bottom, Rear Right	1 ----	----	----	----	1751 774
		Left	1 ----	----	----	----	1751 775
	Lock Pillar to Lock Pillar Angle		2 ----	----	----	----	*1690 874
	Sp.Cl.Cp.	Hinge Pillar, Right	1 ----	----	----	----	1810 704
		Left	1 ----	----	----	----	1810 705

★ Indicates use as required.

☐ Indicates parts not listed in any previous parts book.

* Indicates change or addition.

Printed in U.S.A.

Prices and specifications subject to change without notice.

CODE	REMARKS	PER CAR	PLYMOUTH	DODGE	DESOTO	CHRYSLER	IMPERIAL
23-63-O WEATHERSTRIP Cont'd							
23-63-33	WEATHERSTRIP - Cont'd Sp.Cl.Cp., Cv.Cp.						
	Right	1	1952 852	1952 852	1952 852	1952 852	---- --
	Left	1	1952 853	1952 853	1952 853	1952 853	---- --
	Bottom, Right	1	----	----	----	----	1751 744
	Left	1	----	----	----	----	1751 745
	Lock Pillar, Front Right	1	----	----	----	----	1751 646
	Left	1	----	----	----	----	1751 647
	Cv.Cp. Hinge Pillar, Right	1	----	----	----	----	1810 706
	Left	1	----	----	----	----	1810 707
	Cl. Sed., 2 D. Sub. 4 D. Sub.	2	1954 828	1954 828	----	----	----
	Front	2	1883 504	1883 504	----	----	----
	Rear	2	1883 520	1883 520	----	----	----
	Sp. 4 D., Sub.						
	Front Right	1	2165 304	2165 304	----	2165 304	----
	Left	1	2165 305	2165 305	----	2165 305	----
	Rear Right	1	2165 488	2165 488	----	2165 488	----
	Left	1	2165 489	2165 489	----	2165 489	----
	WEATHERSTRIP, Door Hinge Pillar Auxiliary						
	Right	1	----	----	----	----	1751 570
	Left	1	----	----	----	----	1751 571
	WEATHERSTRIP, Roof Side Rail Sp.4 D., Sp.4 D.Sub.						
	Right	1	2094 484	2094 484	2094 484	2094 484	2093 628
	Left	1	2094 485	2094 485	2094 485	2094 485	2093 629
	Sp.Cl.Cp.						
	Right	1	2094 484	2094 484	2094 484	2094 484	2093 630
	Left	1	2094 485	2094 485	2094 485	2094 485	2093 631
	WEATHERSTRIP, Roof Rail Door Header Rear Sp. 4 D.						
	Right	1	----	----	----	----	2094 870
	Left	1	----	----	----	----	2094 871
	WEATHERSTRIP, Rear Door Upper Hinge Side Sp. 4 D., Sp. 4 D. Sub.						
	Right	1	2165 484	2165 484	2165 484	2165 484	----
	Left	1	2165 485	2165 485	2165 485	2165 485	----
	SEAL, Door Vent Wing Frame Front Corner Cv.Cp.						
	Upper, Right	1	1954 718	1954 718	----	1954 718	----
	Left	1	1954 719	1954 719	----	1954 719	----
	WEATHERSEAL, Body Lock Pillar Belt to Door						
	Sp.Cl.Cp., Cv.Cp.						
	Right	1	1954 618	1954 618	1954 618	1954 618	----
	Left	1	1954 619	1954 619	1954 619	1954 619	----
23-63-37	SEAL, Roof Rail Weatherstrip Retainer to Roof Rail						
	Sp. 4 D.	2	----	----	----	----	2094 581
23-63-55	RETAINER, Roof Side Rail Weatherstrip Sp. 4 D., D3, D4						
	Right	1	1883 290	1883 290	----	----	2093 714
	Left	1	1883 291	1883 291	----	----	2093 715
	Sp. 4 D., Sp. 4 D.Sub., D1, D2						
	Pkg., Right	1	----	2196 671	2196 671	2196 671	----
	Left	1	----	2196 672	2196 672	2196 672	----
	SCREW	32	----	125 978	125 978	125 978	----
	Sp.Cl.Cp.						
	Right	1	1883 294	1883 294	----	----	2093 366
	Left	1	1883 295	1883 295	----	----	2093 367
	Sp.Cl.Cp.						
	Pkg., Right	1	----	----	2196 669	2196 669	----
	Left	1	----	----	2196 670	2196 670	----
	SCREW	24	----	----	125 978	125 978	----
23-63-56	EXTENSION, Roof Side Rail Rear Weather- strip Retainer						
	Sp.Cl.Cp.						
	Right	1	1954 864	1954 864	----	----	----
	Left	1	1954 865	1954 865	----	----	----
23-63-94	WEATHERSTRIP, Rear Door Window Front Frame						
	Sp. 4 D., Sp. 4 D.Sub.						
	Right	1	1954 544	1954 544	1954 544	1954 544	1810 016
	Left	1	1954 545	1954 545	1954 545	1954 545	1810 017
23-63-97	WEATHERSTRIP, Door Window Glass Lower Channel						
	Sp. 4 D.						
	Front	2	----	----	----	----	1750 517
23-63-100	WEATHERSTRIP, Quarter Window Sub.						
	Right	1	2093 200	2093 200	----	2093 200	----
	Left	1	2093 201	2093 201	----	2093 201	----

★ Indicates use as required.

☐ Indicates parts not listed in any previous parts book.

Dec. 9, 1960 Supersedes April 20, 1960.

Printed in U.S.A.

Prices and specifications subject to change without notice.

1960 PASSENGER CAR PARTS CATALOG

CODE	REMARKS	PER CAR	PLYMOUTH	DODGE	DESOTO	CHRYSLER	IMPERIAL
23-64-O WINDOWS AND VENT WING - Cont'd							
23-64-12	SUPPORT, Rear Door Window Glass Channel Down Position Stop Bracket Sp. 4 D., Sp. 4 D.Sub. w/Electric Window Lifts	2	1963 392	1963 392	1963 392	1963 392	---- --
	BRACKET, Door Window Glass Channel Down Position Stop 4 D., Sp. 4 D., 4 D.Sub., Sp. 4 D.Sub. w/Electric Window Lifts	4	1963 393	1963 393	1963 393	1963 393	---- --
	BRACKET, Door and Quarter Window Glass Channel Down Position Stop Sp.Cl.Cp., Cv.Cp., Cl.Sed. w/Electric Window Lifts	4	1963 393	1963 393	1963 393	1963 393	---- --
	BRACKET, Door Glass Down Position Stop	2	----	----	----	----	*1475 487
	BRACKET, Rear Door Window Down Position Stop Sp. 4 D.	2	----	----	----	----	1750 606
	BRACKET, Quarter Window Down Position Stop Sp.Cl.Cp., Cv.Cp.	2	----	----	----	----	1750 806
	SUPPORT, Quarter Window Down Position Stop Sp.Cl.Cp., Cv.Cp.	2	----	----	----	----	1750 537
	STOP, Front Door Window Up Position, on Door Sp. 4 D., Sp. 4 D.Sub., Sp.Cl.Cp., Cv.Cp.	4	1909 529	1909 529	1909 529	1909 529	---- --
	Sp. 4 D., Sp.Cl.Cp., Cv.Cp.	4	----	----	----	----	1750 609
	STOP, Rear Door Window Up Position, on Rear Track Sp. 4 D.	1	----	----	----	----	1751 692
	Right	1	----	----	----	----	1751 693
	Left	1	----	----	----	----	
	STOP, Rear Door Window Up Position, on Door Sp. 4 D., Sp. 4 D.Sub.	2	1909 529	1909 529	1909 529	1909 529	---- --
	Front	2	1909 530	1909 530	1909 530	1909 530	---- --
	Rear	2	1909 530	1909 530	1909 530	1909 530	---- --
	Upper Front, Right	1	----	----	----	----	1751 698
	Left	1	----	----	----	----	1751 699
	STOP, Quarter Window Up Position, on Door Sp.Cl.Cp. Rear	2	1909 530	1909 530	1909 530	1909 530	---- --
	SUPPORT, Quarter Window Up Position Stop Bumper, on Glass Lower Channel Sp.Cl.Cp., Cv.Cp.	1	----	----	----	----	1750 658
	Front Right	1	----	----	----	----	1750 659
	Left	1	----	----	----	----	1691 104
	Cv.Cp. Rear Right	1	----	----	----	----	1691 105
	Left	1	----	----	----	----	
	STOP, Quarter Window Up Position, on Quarter Inside Panel Sp.Cl.Cp.	2	1963 222	1963 222	1963 222	1963 222	---- --
23-64-13	SCREW and WASHER, Door Window Stop to Door Panel	4	----	----	----	----	*6006 082
	CLIP and BOLT, Rear Door Window Up Position Stop to Track Sp. 4 D.	2	----	----	----	----	6006 130
23-64-34	RIVET, Quarter Window Frame to Weatherstrip Retainer Sp.Cl.Cp., Cv.Cp.	★	----	----	----	----	6000 143
23-64-41	STUD, Front Door Vent Wing Adjusting	★	*1950 830	*1950 830	*1950 830	*1950 830	*6006 408
23-64-44	STUD, Door Vent Wing Divisional Channel Lower Bracket Adjusting 4 D.	2	----	----	----	----	6022 001
23-64-47	CAP, Door Vent Wing Frame Lower Corner Sp. 4 D., Sp.Cl.Cp., Cv.Cp., Sp. 4 D.Sub. PKG., Right	1	*2166 618	*2166 618	*2166 616	*2166 616	----
	Left	1	2166 619	2166 619	2166 617	2166 617	----
	NUT	2	6022 075	6022 075	6022 075	6022 075	----

★ Indicates use as required.

⊞ Indicates parts not listed in any previous parts book.

Dec. 9, 1960 Supersedes April 20, 1960.

Printed in U.S.A.

Prices and specifications subject to change without notice.

* Indicates change or addition.

CODE	REMARKS	PER CAR	PLYMOUTH	DODGE	DESOTO	CHRYSLER	IMPERIAL
23-64-O WINDOWS AND VENT WING - Cont'd							
23-64-48	FRAME and DIVISION CHANNEL, Door Vent Wing Sp. 4 D., Sp. Cl. Cp., Cv. Cp., Sp. 4 D. Sub.						
	Right	1	1952 348	1952 348	1952 348	1952 348	---- --
	Left	1	1952 349	1952 349	1952 349	1952 349	---- --
	Sp. 4 D., Sp. Cl. Cp., Cv. Cp. w/Power Vent, Right	1	----	----	----	----	2093 942
	Left	1	----	----	----	----	2093 943
	w/o Power Vent, Right	1	----	----	----	----	1960 948
	Left	1	----	----	----	----	1960 949
23-64-60	RIVET, Door Vent Wing except 4 D., Cl. Sed., 2 D. Sub.	2	1578 269	1578 269	1578 269	1578 269	---- --
23-64-66	FRAME, Rear Window Opening Upper						
	4 D., D3H, D4H w/High Window	1	----	1963 228	1963 229	1963 229	---- --
	4 D., D3, D4 w/Low Window	1	1909 320	1909 320	1909 322	1909 322	---- --
	D1, D2 w/Low Window	1	----	1909 322	----	----	---- --
	Sp. 4 D., D3H, D4H, S3 w/High Window	1	1963 228	1963 228	1963 229	1963 229	---- --
	Sp. 4 D., D1, D2 w/High Window	1	----	1963 229	----	----	---- --
	Sp. 4 D., D3M, D4M w/Low Window	1	1909 320	1909 320	----	----	---- --
	Sp. 4 D., D1, S1, C1, C2 w/Low Window	1	----	1909 322	1909 322	1909 322	---- --
	Sp. Cl. Cp. w/High Window	1	1963 306	1963 306	----	----	---- --
	Sp. Cl. Cp., P1M, P2M, D3M, D4M, D1 w/Low Window	1	1909 321	1909 321	----	----	---- --
	Cl. Sed.	1	1909 320	1909 320	----	----	---- --
	Sp. Cl. Cp. w/High Window	1	----	----	1909 323	1909 323	---- --
	4 D., Sp. 4 D.	1	----	----	----	----	*1877 358
	Sp. Cl. Cp.	1	----	----	----	----	*1877 359
	FRAME, Rear Window Opening Side						
	4 D., D1, D2, S1 w/Low Window, Right	1	1869 892	1882 020	1882 020	1882 020	---- --
	Left	1	1869 893	1882 021	1882 021	1882 021	---- --
	D3, D4 w/Low Window, Right	1	----	1869 892	----	----	---- --
	Left	1	----	1869 893	----	----	---- --
	4 D., S3 w/High Window, Right	1	----	----	1952 878	1952 878	---- --
	Left	1	----	----	1952 879	1952 879	---- --
	4 D. Right	1	----	----	----	----	1877 360
	Left	1	----	----	----	----	1877 361
	Sp. 4 D., D1, S1, C1, C2 w/Low Window, Right	1	----	1882 020	1882 020	1882 020	---- --
	Left	1	----	1882 021	1882 021	1882 021	---- --
	Sp. 4 D., D1, D2 w/High Window, Right	1	1952 876	1952 878	1952 878	1952 878	---- --
	Left	1	1952 877	1952 879	1952 879	1952 879	---- --
	D3, D4 w/High Window, Right	1	----	1952 876	----	----	---- --
	Left	1	----	1952 877	----	----	---- --
	Sp. 4 D. Right	1	----	----	----	----	1877 360
	Left	1	----	----	----	----	1877 361
	Sp. Cl. Cp. Right	1	----	----	1861 142	1861 142	1877 362
	Left	1	----	----	1861 143	1861 143	1877 363
	Cl. Sed. w/Low Window, Right	1	1869 892	1869 892	----	----	---- --
	Left	1	1869 893	1869 893	----	----	---- --
	FRAME, Rear Window Opening Lower End						
	4 D., Sp. 4 D., D1, D2 Right	1	----	1954 668	1954 668	1954 668	---- --
	Left	1	----	1954 669	1954 669	1954 669	---- --
23-64-67	REINFORCEMENT, Rear Window Opening Upper Frame						
	4 D., Sp. 4 D. Right	1	----	----	----	----	*1877 364
	Left	1	----	----	----	----	*1877 365
	Sp. Cl. Cp. Right	1	----	----	----	----	*1877 390
	Left	1	----	----	----	----	*1877 391
23-64-68	EXTENSION, Rear Window Opening Frame						
	Sp. Cl. Cp., P1M, P2M, D1, D3M, D4M Upper Right	1	1884 562	1884 562	----	----	---- --
	Left	1	1884 563	1884 563	----	----	---- --
	Sp. Cl. Cp. w/High Window, Upper Right	1	1952 686	1952 686	----	----	---- --
	Left	1	1952 687	1952 687	----	----	---- --
	Sp. Cl. Cp. Lower Right	1	1909 608	1909 608	----	----	---- --
	Left	1	1909 609	1909 609	----	----	---- --

★ Indicates use as required.

☐ Indicates parts not listed in any previous parts book.

* Indicates change or addition.

Printed in U.S.A.

Prices and specifications subject to change without notice.

CODE	REMARKS	PER CAR	PLYMOUTH	DODGE	DESOTO	CHRYSLER	IMPERIAL
23-64-0 WINDOWS AND VENT WING - Cont'd							
23-64-69	PLUG, Rear Window Upper Frame to Wheelhouse; Sp.Cl. Cp.	2	2165 024	2165 024	----	----	----
23-64-70	GUSSET, Rear Window Upper Frame to Wheelhouse Sp.Cl. Cp., P1H, P2H, D3, D4						
	w/High Window, Right	1	1952 678	1952 678	----	----	----
	Left	1	1952 679	1952 679	----	----	----
	Sp.Cl. Cp., D1, D2 w/High Window, Right	1	----	1954 496	----	----	----
	Left	1	----	1954 497	----	----	----
	Sp.Cl. Cp., D1 w/Low Window, Right	1	----	1884 612	----	----	----
	Left	1	----	1884 613	----	----	----
	Sp.Cl. Cp., P1M, P2M, D3M, D4M						
	w/Low Window, Right	1	1884 610	1884 610	----	----	----
	Left	1	1884 611	1884 611	----	----	----
23-64-71	BUMPER or PLUG, Door Glass Upper Corner, on Division Channel Sp. 4 D., Sp.Cl. Cp., Cv. Cp., Sp. 4 D. Sub.						
	Right	1	1964 228	1964 228	1964 228	1964 228	2093 809
	Left	1	1964 229	1964 229	1964 229	1964 229	2093 809
23-64-74	SEAL, Door Vent Wing to Door Inner Panel Sp. 4 D., Sp. 4 D. Sub., Sp.Cl. Cp., Cv. Cp.	2	2165 519	2161 519	2161 519	2161 519	----
23-64-75	MOTOR and TRANSMISSION, Electric Vent Wing						
	Right	1	----	----	----	----	2093 030
	Left	1	----	----	----	----	2093 031
23-64-76	BRACKET, Electric Vent Wing Motor Mounting						
	Right	1	----	----	----	----	1961 802
	Left	1	----	----	----	----	1961 803
23-64-78	DRIVE SHAFT, Gear and Retainer, Electric Vent Wing						
	Right	1	----	----	----	----	2093 048
	Left	1	----	----	----	----	2093 049
23-64-79	COUPLING, Electric Vent Wing Shaft to Pivot	2	----	----	----	----	1961 977
23-64-83	SHIM, Electric Vent Wing Motor Mounting Bracket to Door	2	----	----	----	----	B6006 512
23-64-174	GLASS, Frame and Lower Channel, Quarter Window (see Note 1) Sp.Cl. Cp.						
	Right	1	1909 430	1909 430	1961 782	1961 782	----
	Left	1	1909 431	1909 431	1961 783	1961 783	----
	Solex, Right	1	1909 432	1909 432	1961 784	1961 784	----
	Left	1	1909 433	1909 433	1961 785	1961 785	----
	Cv. Cp. Right	1	1909 682	1909 682	----	1909 688	----
	Left	1	1909 683	1909 683	----	1909 689	----
	Solex, Right	1	1909 684	1909 684	----	1909 690	----
	Left	1	1909 685	1909 685	----	1909 691	----
23-64-197	GUIDE, Quarter Window Glass Lower Frame Stabilizer Sp.Cl. Cp.	4	----	----	1961 681	1961 681	----
23-64-198	CHANNEL, Quarter Window Glass Lower Frame Stabilizer Sp.Cl. Cp.						
	Right	1	----	----	1961 822	1961 822	----
	Left	1	----	----	1961 823	1961 823	----
23-64-237	CLAMP, Door Vent Wing Upper Pivot to Glass	2	*1708 998	*1708 998	*1708 998	*1708 998	----
	PLATE, Door Vent Wing Upper Pivot to Glass Base Anchor	2	----	----	----	----	*1755 366
23-64-240	PIVOT, Front Door Vent Wing Upper						
	4 D., 4 D. Sub., 2 D. Sub., Cl. Sed. Right	1	1950 356	1950 356	1950 356	1950 356	1960 036
	Left	1	1950 357	1950 357	1950 357	1950 357	1960 037
23-64-242	CLAMP, Door Vent Wing Lower Pivot Tension						
	Right	1	1776 504	1776 504	1776 504	1776 504	----
	Left	1	1776 505	1776 505	1776 505	1776 505	----
	BRACKET, Door Vent Wing Upper Pivot Sp. 4D., Sp.Cl. Cp., Cv. Cp.						
	Right	1	1950 292	1950 292	1950 292	1950 292	1690 952
	Left	1	1950 293	1950 293	1950 293	1950 293	1690 953
	4D., 4D. Sub., 2D. Sub., Cl. Sed. Right	1	1950 292	1950 292	1950 292	1950 292	1751 328
	Left	1	1950 293	1950 293	1950 293	1950 293	1751 329

★ Indicates use as required.

E Indicates parts not listed in any previous parts book.

Dec. 9, 1960 Supersedes April 20, 1960.

Printed in U.S.A.

Prices and specifications subject to change without notice.

* Indicates change or addition.

CODE	REMARKS	PER CAR	PLYMOUTH	DODGE	DESOTO	CHRYSLER	IMPERIAL
23-64-0 WINDOWS AND VENT WING - Cont'd							
23-64-242	BRACKET and PIVOT - Cont'd Sp. 4 D., Sp. 4D. Sub., Sp. Cl. Cp., Cv. Cp. Right	1	*2166 680	*2166 680	*2166 680	*2166 680	*2094 462
	Left	1	2166 681	2166 681	2166 681	2166 681	2094 463
23-64-246	SHIM, Door Vent Wing Frame to Door Sp. 4 D., Sp. Cl. Cp., Cv. Cp.	★	----	----	----	----	1349 190
23-64-247	SCREW, Door Vent Wing Upper Pivot Anchor Plate or Clamp	2	*6000 374	*6000 374	*6000 374	*6000 374	*6000 374
	SCREW, Door Vent Wing Lower Tension Clamp Adjusting	2	6006 244	6006 244	6006 244	6006 244	6006 244
	4 D., Cl. Sed., Sub.	2	----	----	----	----	6006 244
	Sp. Cl. Cp., Cv. Cp.	2	----	----	----	----	6006 244
23-64-254	TRACK, Rear Door Window Roller 4 D., 4 D. Sub.	Right 1	2165 294	2165 294	2165 294	2165 294	----
		Left 1	2165 295	2165 295	2165 295	2165 295	----
	Sp. 4 D., Sp. 4 D. Sub.	Front Right 1	1883 884	1883 884	1883 884	1883 884	----
		Left 1	1883 885	1883 885	1883 885	1883 885	----
		Rear 2	1954 418	1954 418	1954 418	1954 418	----
NOTE: Also see Part Type Code 23-09-51 and 23-09-56.							
23-64-255	FRAME or EXTENSION, Door Window Glass 4 D.	Front Upper, Right 1	----	----	----	----	1877 480
		Left 1	----	----	----	----	1877 481
	w/Electric Vent Wing, Right	1	----	----	----	----	1961 812
	Left	1	----	----	----	----	1961 813
	Rear Upper, Right	1	----	----	----	----	1877 372
	Left	1	----	----	----	----	1877 373
	w/BRACKET, Rear Right	1	----	----	----	----	2093 660
	Left	1	----	----	----	----	2093 661
	FRAME or EXTENSION, Front Door Window Glass Sp. 4 D.	Right 1	----	----	----	----	1750 534
		Left 1	----	----	----	----	1750 535
	FRAME or EXTENSION, Door Window Sp. Cl. Cp., Cv. Cp.	Front Right 1	----	----	----	----	1751 092
		Left 1	----	----	----	----	1751 093
	FRAME or EXTENSION, Rear Door Window Glass Sp. 4 D.	Upper and Front Right 1	----	----	----	----	1691 842
		Left 1	----	----	----	----	1691 843
		Rear Right 1	----	----	----	----	1691 788
		Left 1	----	----	----	----	1691 789
23-64-261	BOLT and WASHER, Door Upper Extension or Window Opening Frame Attaching 4 D., 5/16"-18 x 3/8"	★	----	----	----	----	6000 324
	5/16"-18 x 5/8"	★	----	----	----	----	6000 325
23-64-262	NUT, Door Upper Extension or Window Opening Frame Attaching 4 D.	★	----	----	----	----	6006 005
23-64-263	WASHER, Window Roller Track Adjusting Stud to Panel Sp. 4 D., Sp. Cl. Cp., Cv. Cp.	★	----	----	----	----	6006 192
23-64-265	GLASS, Frame and Lower Channel, Front Door Window (see Note 1) Sp. 4 D., Sp. 4 D. Sub.	Right 1	1909 694	1909 694	1909 694	1909 694	----
		Left 1	1909 695	1909 695	1909 695	1909 695	----
		Solex, Right 1	1909 696	1909 696	1909 696	1909 696	----
		Left 1	1909 697	1909 697	1909 697	1909 697	----
	GLASS, Frame and Lower Channel, Rear Door Window Sp. 4 D., D1, D2	Right 1	1909 704	1909 698	1909 698	1909 698	----
		Left 1	1909 705	1909 699	1909 699	1909 699	----
		Solex, Right 1	1909 706	1909 700	1909 700	1909 700	----
		Left 1	1909 707	1909 701	1909 701	1909 701	----

★ Indicates use as required.

□ Indicates parts not listed in any previous parts book.

* Indicates change or addition.

CODE	REMARKS	PER CAR	PLYMOUTH	DODGE	DESOTO	CHRYSLER	IMPERIAL
23-64-O WINDOWS AND VENT WING - Cont'd							
23-64-265	GLASS - Cont'd D3, D4						
	Right	1	----	1909 704	----	----	----
	Left	1	----	1909 705	----	----	----
	Solex, Right	1	----	1909 706	----	----	----
	Left	1	----	1909 707	----	----	----
	Sp. 4 D. Sub.						
	Right	1	1909 698	1909 698	----	1909 698	----
	Left	1	1909 699	1909 699	----	1909 699	----
	Solex, Right	1	1909 700	1909 700	----	1909 700	----
	Left	1	1909 701	1909 701	----	1909 701	----
	4 D.						
	Less Frame, Right	1	----	----	----	----	2093 554
	Left	1	----	----	----	----	2093 555
	Less Frame, Solex, Right	1	----	----	----	----	2093 556
	Left	1	----	----	----	----	2093 557
	GLASS, Frame and Lower Channel, Door Window						
	Sp. Cl. Cp., Cv. Cp.						
	Right	1	1909 302	1909 302	1909 710	1909 710	----
	Left	1	1909 303	1909 303	1909 711	1909 711	----
	Solex, Right	1	1909 304	1909 304	1909 712	1909 712	----
	Left	1	1909 305	1909 305	1909 713	1909 713	----
23-64-273	SUPPORT, Door Vent Wing Divisional Channel to Inside Lower Panel	2	*1909 856	*1909 856	*1909 856	*1909 856	----
23-64-275	STUD and WASHER, Window Roller Track Adjusting	★	1883 554	1883 554	1883 554	1883 554	----
	Sp. 4 D., Sp. 4 D. Sub., Sp. Cl. Cp., Cv. Cp.						
	Upper	★	----	----	----	----	6006 409
	Lower	★	----	----	----	----	6006 296
23-64-278	GROMMET, Door Vent Wing Upper Pivot Bracket to Glass	2	*1909 917	*1909 917	*1909 917	*1909 917	*1751 492
23-64-279	WASHER or INSULATOR, Door Vent Wing Upper Pivot Bracket Anchor Plate or Clamp to Glass	2	----	----	----	----	*1751 489
23-64-280	PANEL, Quarter Window Opening Cl. Sed., 2 D. Sub.						
	Front Right	1	1869 868	1869 868	----	----	----
	Left	1	1869 869	1869 869	----	----	----
	Cl. Sed.						
	Upper Right	1	1869 872	1869 872	----	----	----
	Left	1	1869 873	1869 873	----	----	----
	2 D. Sub.						
	Upper Right	1	1884 522	----	----	----	----
	Left	1	1884 523	----	----	----	----
	FRAME, Quarter Window Sub.						
	Front Right	1	1960 066	1960 066	----	1960 066	----
	Left	1	1960 067	1960 067	----	1960 067	----
	FRAME, Quarter Window Glass Sp. Cl. Cp., Cv. Cp.						
	Front Right	1	----	----	----	----	1751 890
	Left	1	----	----	----	----	1751 891
	Upper and Rear Right	1	----	----	----	----	1691 616
	Left	1	----	----	----	----	1691 617
23-64-299	TRACK or CHANNEL, Quarter Window Roller Sp. Cl. Cp.						
	Front Right	1	----	----	----	----	1810 860
	Left	1	----	----	----	----	1810 861
	Rear Right	1	----	----	----	----	1810 862
	Left	1	----	----	----	----	1810 863
	Cv. Cp.						
	Front Right	1	1952 620	1952 620	----	1952 620	1810 860
	Left	1	1952 621	1952 621	----	1952 621	1810 861
	Rear Right	1	Ⓛ1952 994	Ⓛ1952 994	----	Ⓛ1952 994	1810 862
	Left	1	Ⓛ1952 995	Ⓛ1952 995	----	Ⓛ1952 995	1810 863
	Cl. Sed., 2D. Sub.						
	Right	1	2165 294	2165 294	----	----	----
	Left	1	2165 295	2165 295	----	----	----
	Sp. Cl. Cp.	2	1952 725	1952 725	*1952 725	*1952 725	----

★ Indicates use as required.

Ⓛ Indicates parts not listed in any previous parts book.

Dec. 9, 1960 Supersedes April 20, 1960.

Printed in U.S.A.

Prices and specifications subject to change without notice.

CODE	REMARKS	PER CAR	PLYMOUTH	DODGE	DESOTO	CHRYSLER	IMPERIAL
23-64-0 WINDOWS AND VENT WING - Cont'd							
23-64-306	GLASS, Lower Pivot and Bracket, Door Vent Wing (see Note 1)						
	4 D., 4 D. Sub., 2 D. Sub., Cl. Sed						
	Right	1	1954 104	1954 104	1954 104	1954 104	----
	Left	1	1954 105	1954 105	1954 105	1954 105	----
	Solex, Right	1	1954 106	1954 106	1954 106	1954 106	----
	Left	1	1954 107	1954 107	1954 107	1954 107	----
	Sp. 4 D., Sp. 4 D. Sub., Sp. Cl. Cp., Cv. Cp.						
	Right	1	1954 100	1954 100	1954 100	1954 100	----
	Left	1	1954 101	1954 101	1954 101	1954 101	----
	Solex, Right	1	1954 102	1954 102	1954 102	1954 102	----
	Left	1	1954 103	1954 103	1954 103	1954 103	----
	4D., Y1L, Y1M						
	Right	1	----	----	----	----	1961 276
	Left	1	----	----	----	----	1961 277
	Solex, Right	1	----	----	----	----	1961 278
	Left	1	----	----	----	----	1961 279
	4D. Sed. w/Power Vent Windows,						
	Right	1	----	----	----	----	1961 930
	Left	1	----	----	----	----	1961 931
	Solex, Right	1	----	----	----	----	1961 932
	Left	1	----	----	----	----	1961 933
	Sp. 4D., Sp. Cl. Cp., Cv. Cp., Y1L, Y1M						
	Right	1	----	----	----	----	1961 190
	Left	1	----	----	----	----	1961 191
	Solex, Right	1	----	----	----	----	1961 192
	Left	1	----	----	----	----	1961 193
	Sp. 4 D., Sp. Cl. Cp., Cv. Cp.						
	w/Power Vent Windows, Right	1	----	----	----	----	1961 848
	Left	1	----	----	----	----	1961 849
	Solex, Right	1	----	----	----	----	1961 850
	Left	1	----	----	----	----	1961 851
23-64-308	GLASS, Front Door Window (see Note 2)						
	4 D., 4 D. Sub.						
	Solex	2	1883 268	1883 268	1883 268	1883 268	----
	Right	2	1883 269	1883 269	1883 269	1883 269	----
	4 D.						
	Right	1	----	----	----	----	1877 660
	Left	1	----	----	----	----	1877 661
	Solex, Right	1	----	----	----	----	1877 662
	Left	1	----	----	----	----	1877 663
	Sp. 4 D.						
	Right	1	----	----	----	----	1691 156
	Left	1	----	----	----	----	1691 157
	Solex, Right	1	----	----	----	----	1691 196
	Left	1	----	----	----	----	1691 197
	GLASS, Rear Door Window						
	4 D., D3, D4						
	Solex	2	1950 255	1950 255	1883 271	1883 271	----
	Right	2	1950 256	1950 256	1883 272	1883 272	----
	Left	2	----	1883 271	----	----	----
	D1, D2						
	Right	1	----	1883 272	----	----	1691 152
	Sp. 4 D.						
	Left	1	----	----	----	----	1691 153
	Solex, Right	1	----	----	----	----	1691 174
	Left	1	----	----	----	----	1691 175
	4 D. Sub.						
	Solex	2	1883 271	1883 271	----	----	----
	Right	2	1883 272	1883 272	----	----	----
	GLASS, Door Window						
	Sp. Cl. Cp., Cv. Cp.						
	Right	1	----	----	----	----	1691 076
	Left	1	----	----	----	----	1691 077
	Solex, Right	1	----	----	----	----	1691 078
	Left	1	----	----	----	----	1691 079
	2 D. Sub., Cl. Sed.						
	Solex	2	1884 888	1884 888	----	----	----
	Right	2	1884 889	1884 889	----	----	----

★ Indicates use as required.

☐ Indicates parts not listed in any previous parts book.

* Indicates change or addition.

CODE	REMARKS	PER CAR	PLYMOUTH	DODGE	DESOTO	CHRYSLER	IMPERIAL
23-64-0 WINDOWS AND VENT WING - Cont'd							
23-64-311	GLASS, Quarter Window (see Note 2)						
	Sub. Stationary, Right	1	1878 180	1878 180	----	1878 180	----
	Left	1	1878 181	1878 181	----	1878 181	----
	Stationary, Solex, Right	1	1878 184	1878 184	----	1878 184	----
	Left	1	1878 185	1878 185	----	1878 185	----
	2 D.Sub. Front	2	1950 683	----	----	----	----
	Solex, Front	2	1950 684	----	----	----	----
	Cl.Sed. Solex	2	1950 667	1950 667	----	----	----
	Solex, Right	2	1950 668	1950 668	----	----	----
	Sp.Cl.Cp., Cv.Cp. Right	1	----	----	----	----	1691 238
	Left	1	----	----	----	----	1691 239
	Solex, Right	1	----	----	----	----	1691 240
	Left	1	----	----	----	----	1691 241
23-64-314	GLASS, Rear Window (see Note 2)						
	4 D., Cl.Sed., D3, D4, C1, C2	1	1869 628	1869 628	1869 630	1869 630	----
	Solex	1	1954 074	1954 074	1954 217	1954 217	----
	4 D., D1, D2, C3	1	----	*1869 630	----	⊠2165 515	----
	Solex	1	----	1954 217	----	*1952 643	----
	4 D., Y1L, Y1M	1	----	----	----	----	1877 316
	Solex	1	----	----	----	----	1877 323
	Solex and Shaded	1	----	----	----	----	1877 325
	4D., Y1H	1	----	----	----	----	1961 508
	Solex	1	----	----	----	----	1961 646
	Sp.4D., D1, S1, C1, C2	1	----	1869 630	1869 630	1869 630	----
	Solex	1	----	1954 217	1954 217	1954 217	----
	Sp.4 D. w/High Window	1	----	⊠2165 515	⊠2165 515	⊠2165 515	----
	Solex	1	----	*1952 643	*1952 643	*1952 643	----
	Sp.4 D., D3, D4, Y1L, Y1M	1	*2165 514	*2165 514	----	----	*1877 316
	Solex	1	1952 699	*1952 699	----	----	1877 323
	Solex and Shaded	1	----	----	----	----	1877 325
	Sp.4 D., Y1H	1	----	----	----	----	1961 508
	Solex	1	----	----	----	----	1961 646
	Sp.Cl.Cp., P1M, D1, D3M, D4M	1	1869 629	1869 629	1877 958	1877 958	1877 317
	Solex	1	1954 237	1954 237	1878 161	1878 161	1877 322
	Solex and Shaded	1	----	----	----	----	1877 324
	Sp.Cl.Cp. w/High Window	1	⊠1964 261	⊠1964 261	----	----	----
	Solex	1	*1952 668	*1952 668	----	----	----

NOTE: New Yorker Rear Window is Special Equipment for Windsor and Saratoga 4Door Sedans and Special 4 D. Sedans. Polara Rear Window is Special Equipment for Matador Special 4 Door Sedans. Polara or Phoenix Rear Window is Special Equipment for Matador and Pioneer Special Club Coupes.
 Height at Center of Standard Equipment Window Glass is as follows: 4 Door Sedan and Special 4 Door Sedan - New Yorker and Polara, 33 3/4"; Windsor, Saratoga and Matador, 21 3/4"; Special Club Coupe - Polara and Phoenix, 36", Matador and Pioneer, 24 1/2".

23-66-0 WINDSHIELD

NOTE 1: PLACE ORDERS WITH YOUR USUAL SOURCE OF SUPPLY FOR MOPAR PARTS.

NOTE 2: PLACE ORDERS DIRECT WITH PITTSBURGH PLATE GLASS COMPANY.

23-66-135	GLASS, Windshield (see Note 2)	1	*1869 627	*1869 627	*1869 627	*1869 627	*1651 431
	Solex	1	1954 216	1954 216	1954 216	1954 216	1690 871
23-66-235	WEATHERSTRIP, Windshield Glass	1	*1882 146	*1882 146	*1882 146	*1882 146	*2093 638

23-67-0 WINDSHIELD WIPER

23-67-5	ARM, Windshield Wiper						
	S1 Right	1	1704 768	1704 768	1704 768	1779 992	----
	Left	1	1704 769	1704 769	1704 769	1779 993	----
	S3 Right	1	----	----	1779 992	----	----
	Left	1	----	----	1779 993	----	----

★ Indicates use as required.

⊠ Indicates parts not listed in any previous parts book.

Dec. 9, 1960 Supersedes April 20, 1960.

Printed in U.S.A.

Prices and specifications subject to change without notice.

CODE	REMARKS	PER CAR	PLYMOUTH	DODGE	DESOTO	CHRYSLER	IMPERIAL
23-67-0 WINDSHIELD WIPER - Cont'd							
23-67-5	ARM and BLADE, Windshield Wiper						
	Right	1	----	----	----	----	1753 214
	Left	1	----	----	----	----	1753 215
23-67-10	GEAR and DRIVE End Cover Plate GASKET PACKAGE, Windshield Wiper Motor						
	w/Single Speed AutoLite Motor	1	1879 601	1879 601	1879 601	----	----
	w/Variable Speed Motor	1	1879 598	1879 598	1879 598	1879 598	1879 598
23-67-16	BRUSH and SPRING PACKAGE, Windshield Wiper Motor						
	w/Single Speed Motor, AutoLite	1	1752 518	1752 518	1752 518	----	----
	General Industries	1	1886 558	1886 558	1886 558	----	----
	w/Variable Speed Motor	1	1627 273	1627 273	1627 273	1627 273	1627 273
23-67-18	BRACKET, Windshield Wiper Motor Mounting						
	w/Single Speed	1	*1838 293	*1838 293	*1838 293	----	----
	w/Variable Speed	1	1838 289	1838 289	1838 289	1838 289	1838 289
23-67-19	BOLT, Windshield Wiper Mounting Bracket Brace						
		1	----	----	----	*6006 120	*6006 120
23-67-20	GROMMET, Windshield Wiper Motor Mounting						
		3	*1594 992	*1594 992	*1594 992	*1594 992	*1594 992
23-67-25	BLADE, Windshield Wiper						
		2	*1879 499	*1879 499	*1879 499	*1879 499	----
	REFILL, Windshield Wiper Blade	2	*1818 892	*1818 892	*1818 892	*1818 892	*1818 892
23-67-41	WIRING, Windshield Wiper Switch to Motor Connecting						
	w/Variable Speed Wipers	1	1971 628	----	----	----	----
23-67-48	ADAPTER, Windshield Wiper Pivot						
	Right	1	----	----	----	----	1704 062
	Left	1	----	----	----	----	1704 063
23-67-49	GASKET, Windshield Wiper Pivot Adapter						
		2	----	----	----	----	*1704 066
23-67-50	NUT, Windshield Wiper Pivot Adapter						
		2	----	----	----	----	*1770 140
23-67-61	GEAR, Windshield Wiper Motor						
	w/Single Speed Motor, AutoLite	1	1879 601	1879 601	1879 601	----	----
	General Industries	1	1886 557	1886 557	1886 557	----	----
	w/Variable Speed Motor	1	1818 685	1818 685	1818 685	1818 685	1818 685
23-67-62	KEY, Windshield Wiper Motor Gear						
	w/Single Speed AutoLite Motor	1	*1604 243	*1604 243	*1604 243	----	----
23-67-76	LEVER or ARM, Windshield Wiper Link Crank						
	w/Single Speed	1	1838 936	1838 936	1838 936	----	----
	w/Variable Speed	1	1838 292	1838 292	1838 292	1838 292	1838 292
23-67-79	LINK, Windshield Wiper Crank Lever to Pivot						
	w/Single Speed Wipers, Right	1	1838 934	1838 934	1838 934	----	----
	Left	1	1838 935	1838 935	1838 935	----	----
	w/Variable Speed Wiper, Right	1	1842 407	1842 407	1842 407	1842 407	1841 679
	Left	1	1838 291	1838 291	1838 291	1838 291	1841 680
23-67-80	RETAINER, Windshield Wiper Link						
	to Pivot	2	1605 299	1605 299	1605 299	1605 299	1605 299
	to Crank Lever, Right	1	1642 029	1642 029	1642 029	1642 029	1642 029
	Left	1	1886 202	1886 202	1886 202	1886 202	1886 202
23-67-81	WASHER, Windshield Wiper Link to Crank Lever, Felt						
	w/Single Speed Wipers	★	1540 383	1540 383	1540 383	----	----
23-67-82	WASHER, Windshield Wiper Link to Pivot						
	WASHER, Windshield Wiper Link to Crank Lever, Steel	2	*1605 604	*1605 604	*1605 604	*1605 604	*1605 604
	w/Variable Speed Wipers, Plain	1	1770 289	1770 289	1770 289	1770 289	1770 289
	Spring Type	2	1770 290	1770 290	1770 290	1770 290	1770 290
	Shakeproof	1	1770 296	1770 296	1770 296	1770 296	1770 296
23-67-85	GASKET, Windshield Wiper Pivot						
		2	*1887 001	*1887 001	*1887 001	*1887 001	*1704 066

★ Indicates use as required.

□ Indicates parts not listed in any previous parts book.

* Indicates change or addition.

1960 PASSENGER CAR PARTS CATALOG

BODY

CODE	REMARKS	PER CAR	PLYMOUTH	DODGE	DESOTO	CHRYSLER	IMPERIAL
23-67-0 WINDSHIELD WIPER - Cont'd							
23-67-86	PIVOT, Windshield Wiper Arm	2	*1841 191	*1841 191	*1841 191	*1841 191	----
	Right	1	----	----	----	----	1841 682
	Left	1	----	----	----	----	1841 683
23-67-91	SCREW and WASHER, Windshield Wiper Pivot Mounting	4	----	----	----	----	*1704 061
23-67-95	NUT and WASHER, Windshield Wiper Pivot Mounting	4	⊘2076 232	⊘2076 232	⊘2076 232	⊘2076 232	----
23-67-98	MOTOR, Windshield Wiper						
	Single Speed	1	1879 583	1879 583	1879 583	----	----
	Variable Speed	1	1842 964	1842 964	1842 964	1842 964	1842 964
23-67-100	SPACER, Windshield Wiper Motor Mounting Grommet 15/32" hole	3	1594 995	1594 995	1594 995	1594 995	1594 995
23-67-102	WASHER, Windshield Wiper Motor Mounting Screw 9/32" hole	3	1594 993	1594 993	1594 993	1594 993	1594 993
23-67-106	ARMATURE, Windshield Wiper Motor w/Single Speed AutoLite Motor	1	1818 878	1818 878	1818 878	----	----
	w/Variable Speed Motor	1	1818 813	1818 813	1818 813	1818 813	1818 813
23-67-111	COIL, Windshield Wiper Motor Field w/Single Speed AutoLite Motor	1	1818 876	1818 876	1818 876	----	----
	w/Variable Speed Motor	1	1818 810	1818 810	1818 810	1818 810	1818 810
23-67-129	REINFORCEMENT, Windshield Wiper Motor Mounting	1	*1846 350	*1846 350	*1846 350	*1846 350	*1846 350
23-67-160	SWITCH, Windshield Wiper						
	Single Speed	1	2084 297	*1879 267	*1879 267	----	----
	Variable Speed	1	2096 988	1971 705	1971 705	1971 707	----
	Variable Speed, w/Washer ACTUATOR	1	----	----	2096 231	1886 770	1886 769
	S1, Single, Speed, w/Washer ACTUATOR	1	----	----	2096 314	----	----
23-67-161	NUT, Windshield Wiper Switch Mounting	1	*1887 603	----	----	----	*1439 758
23-67-163	CIRCUIT BREAKER, Windshield Wiper w/TERMINAL	1	1770 661	1770 661	1770 661	⊘2097 148	*1886 696
	w/o Terminal	1	1642 384	1642 384	1642 384	1642 384	1642 384
23-67-164	SWITCH CONTACT, Cover PLATE and GASKET PACKAGE, Windshield Wiper Motor Drive End						
	w/Single Speed AutoLite Motor	1	1879 602	1879 602	1879 602	----	----
	w/Variable Speed Motor	1	1879 599	1879 599	1879 599	1879 599	1879 599
23-67-166	TERMINAL, Windshield Wiper Switch Circuit Breaker	1	*1770 660	*1770 660	*1770 660	*1770 660	*1770 660
23-67-190	BEZEL, Windshield Wiper Switch Title Lamp Retainer	1	----	----	----	----	*1887 784
23-67-194	KNOB, Windshield Wiper Switch D1, D2, S3, C2, C3	1	1887 591	1887 860	1887 874	1887 989	1887 934
	D3, D4, S1, C1 w/o Windshield Washers	1	----	2096 309	1887 909	1887 991	----
	w/Windshield WASHERS	1	----	----	1887 874	1887 989	----
23-67-195	BEZEL, Windshield Wiper Switch	1	*1887 602	*1887 789	*2096 381	*1887 962	----
23-67-196	BUTTON, Windshield Wiper Switch Knob w/CLIP	1	----	----	----	1972 512	1972 512
23-67-202	SPRING, Windshield Wiper Link w/Variable Speed Wipers	2	*1605 602	*1605 602	*1605 602	*1605 602	*1605 602
23-67-203	TRIP, Windshield Wiper Link Spring w/Variable Speed Wipers	2	*1753 712	*1753 712	*1753 712	*1753 712	*1753 712
23-67-204	CAM, Windshield Wiper Link w/Variable Speed Wipers	2	*1753 711	*1753 711	*1753 711	*1753 711	*1753 711

★ Indicates use as required.

⊘ Indicates parts not listed in any previous parts book.

Dec. 9, 1960 Supersedes April 20, 1960.

Printed in U.S.A.
Prices and specifications subject to change without notice.

* Indicates change or addition.