

GROUP 10 - ENGINE OILING

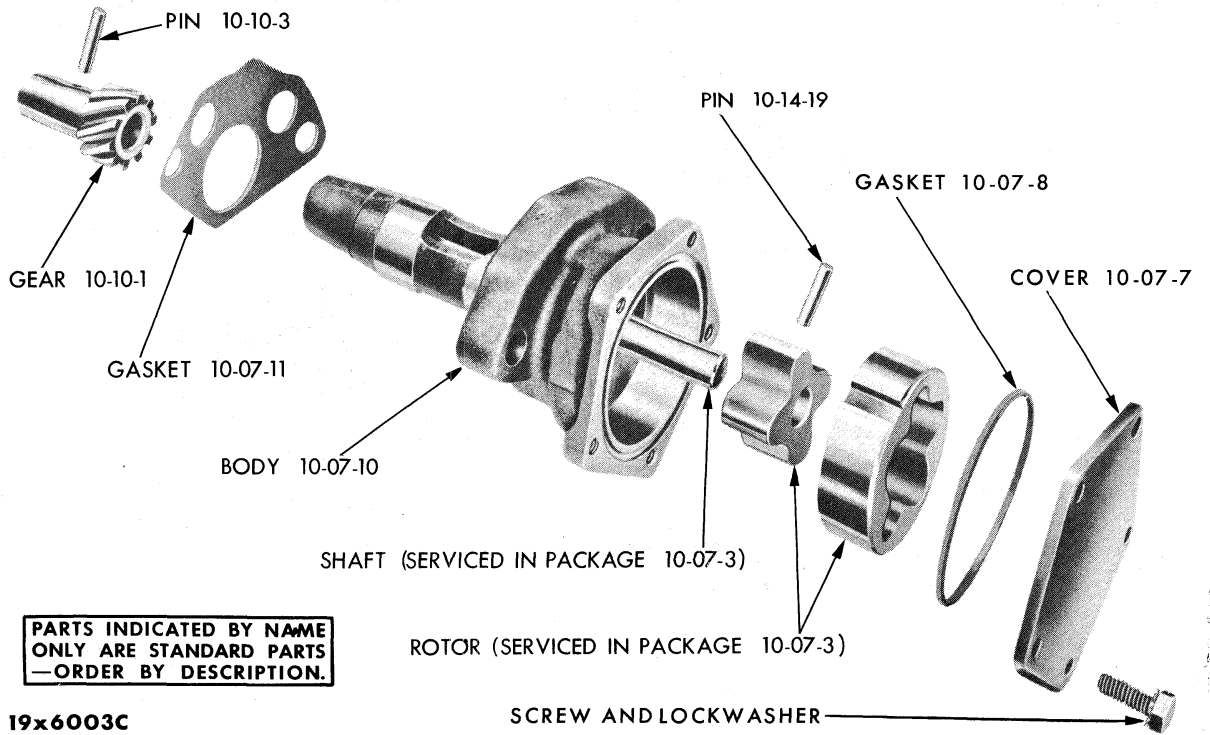

OIL PUMP - 6 CYLINDER

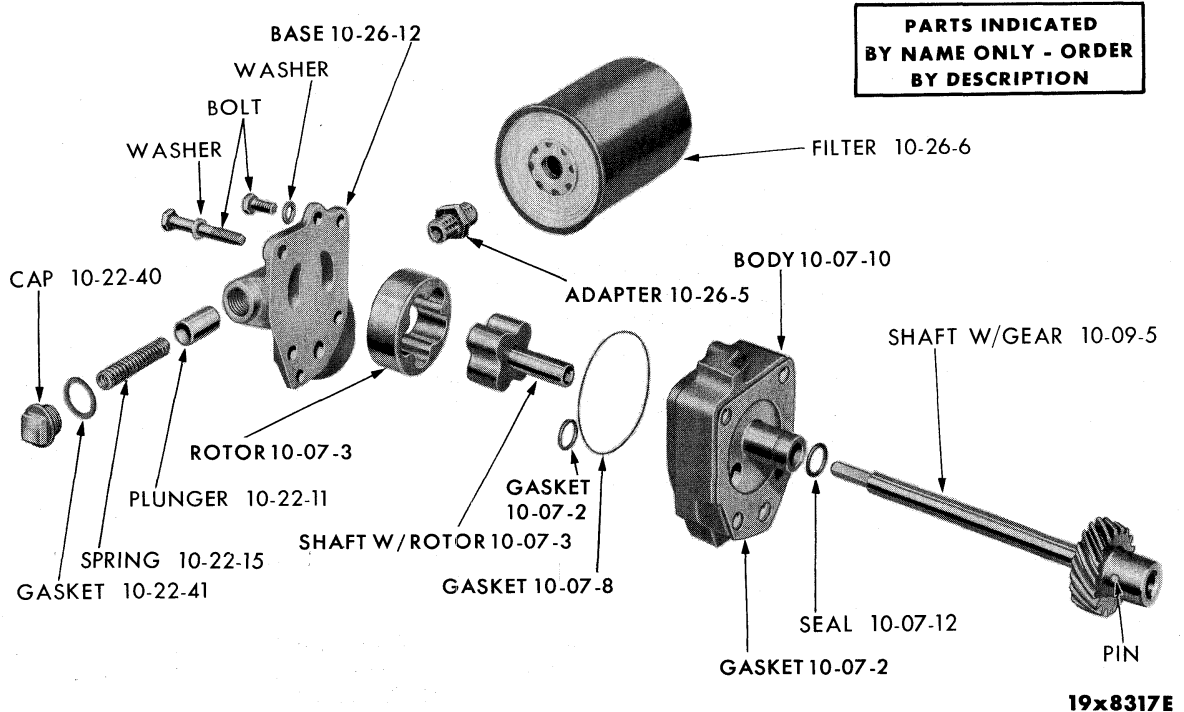

OIL PUMP - (V8 CYLINDER) - EXCEPT PLYMOUTH MP2 (WITHOUT HIGH PERFORMANCE) AND DODGE MD2

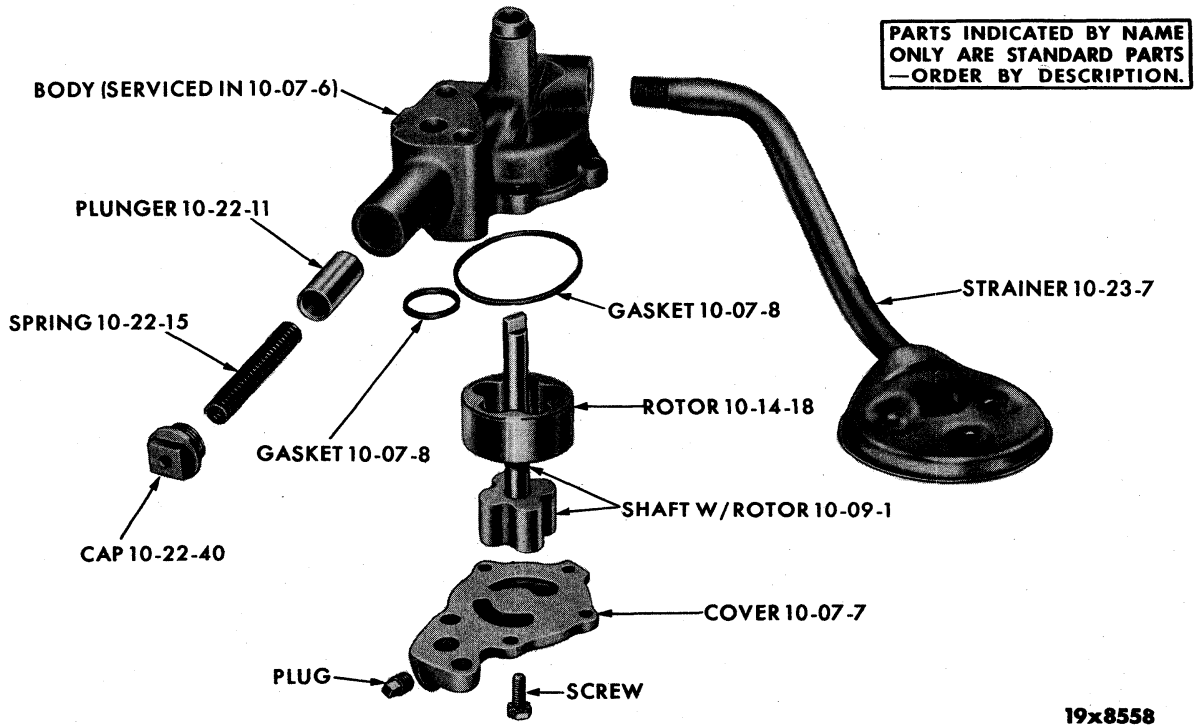

19x8558

OIL PUMP (V8 CYLINDER) - PLYMOUTH MP2 (WITHOUT HIGH PERFORMANCE) AND DODGE MD2

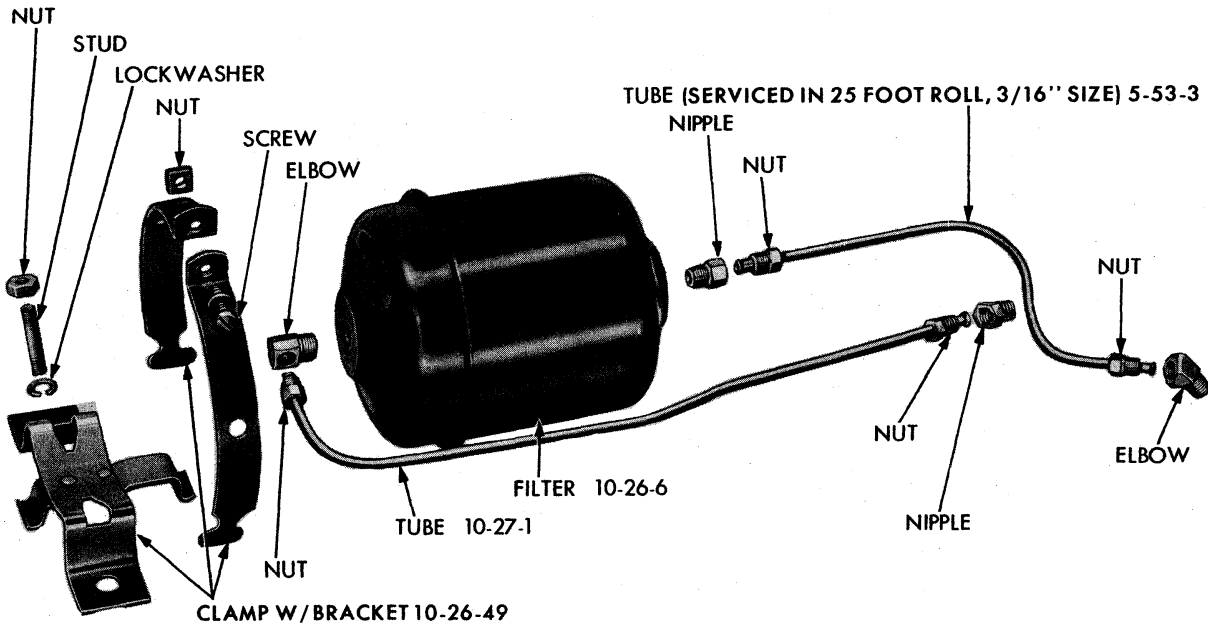

19x6533A

OIL FILTER - SEALED CAN TYPE

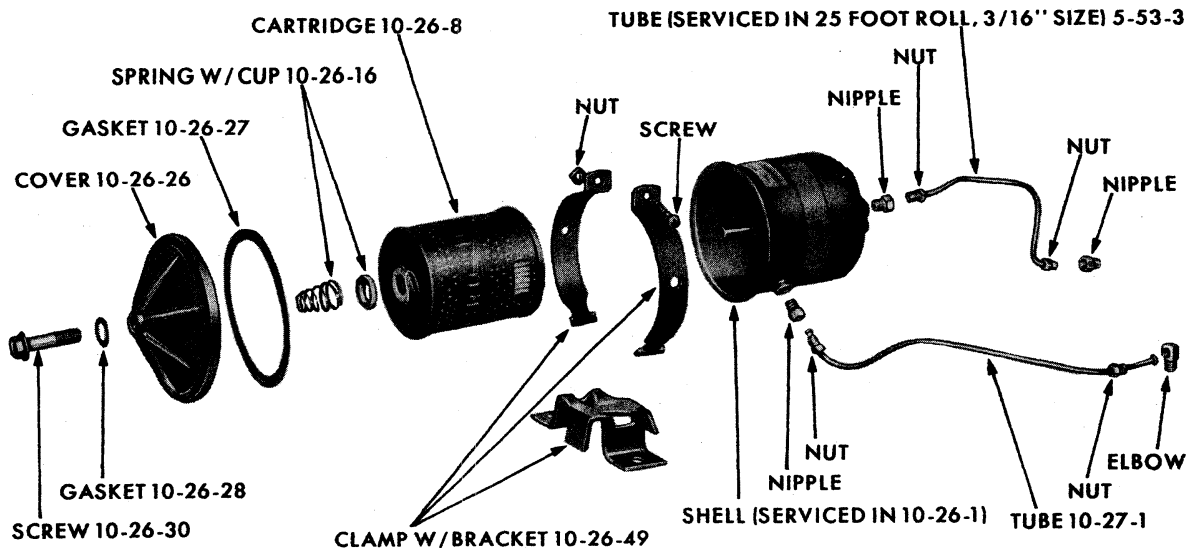

**PARTS INDICATED
BY NAME ONLY - ORDER
BY DESCRIPTION**

19x8537A

OIL FILTER - REPLACEABLE CARTRIDGE TYPE

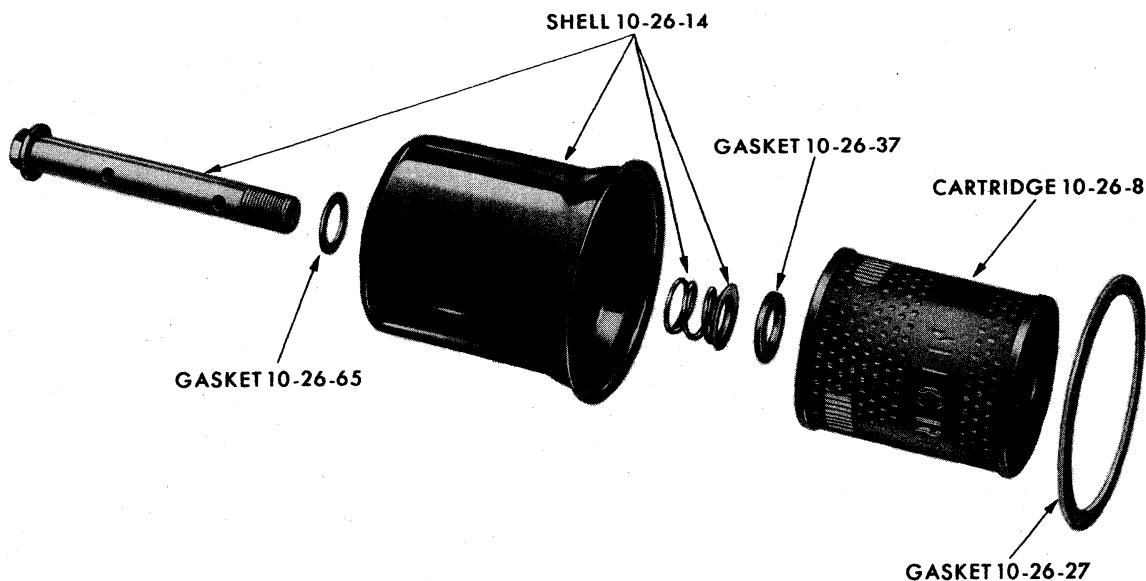

19x8591

OIL FILTER - PLYMOUTH MP2

CODE	PART NAME AND DESCRIPTION	NO. OF CYL.	PLYMOUTH	DODGE	DESOTO	CHRYSLER AND IMPERIAL	PER CAR	PART NUMBER
------	---------------------------	-------------	----------	-------	--------	-----------------------	---------	-------------

GROUP 10 - ENGINE OILING

10-01-0 CRANKCASE BREATHER PIPE								
10-01-9	PIPE, Std.	6	59	-	-	-	1	1827 505
	w/40 or 50 Amp. Gen., w/o Power Steering	6	59	-	-	-	1	1821 553
	MD1, All	6	-	59	-	-	1	1821 553
10-01-10	SCREEN, MD1, All	6	-	59	-	-	1	871 851
10-01-21	AIR CLEANER, Inlet	6-8	59	59	59	59	1	1821 198
10-02-0 CRANKCASE VENTILATOR								
10-02-8	AIR CLEANER, Outlet Pipe, MP1, MD1, All	6	59	59	-	-	1	1315 669
	MP2, MD2, All, w/o High Performance, w/PIPE	8	59	59	-	-	1	1945 191
	MD2-D500, Export, MD3, All	8	-	59	59	-	1	1825 922
	MC1, MC2, MC3, MY1, All, LHD, Export	8	-	-	-	59	1	1825 922
10-02-10	SPACER, Outlet Pipe Air Cleaner, MP1, MD1, All	6	59	59	-	-	1	1610 419
10-02-11	GASKET, Outlet Pipe Air Cleaner, MP1, MD1, All	6	59	59	-	-	1	301 034
10-02-15	PIPE, Outlet, use w/o Air Cleaner, MP1, MD1, All	6	59	59	-	-	1	1821 298
	Use w/Air Cleaner, MP1, MD1, All	6	59	59	-	-	1	1821 916
	Std., use w/o Air Cleaner MP2, MD2	8	59	59	-	-	1	1945 190
	MP2, MD2, All, w/o High Performance, w/Air Cleaner	8	59	59	-	-	1	*1945 191
	Std., use w/o Air Cleaner, MD3, All	8	-	59	59	-	1	1852 057
	Use w/Air Cleaner, MD2-D500, Export, MD3, MS1, MS2, MS3, All	8	-	59	59	-	1	1852 058
	Use w/Air Cleaner LHD., Export	8	-	-	-	59	1	1851 860
	Std., used w/o Air Cleaner	8	-	-	-	59	1	1851 859
10-02-17	GASKET, use w/Air Cleaner, MP1, MD1, All	6	59	59	-	-	1	301 034
10-03-0 OIL LEVEL INDICATOR								
10-03-4	INDICATOR, use w/o Air Cleaner, MP1, MD1, All	6	59	59	-	-	1	1821 878
	MP2, w/o High Performance, MD2, All	8	59	59	-	-	1	1821 169
	MP2 w/High Performance, MD2-D500, MD3, All	8	59	59	59	59	1	1858 907
10-03-7	TUBE, MP1, MD1, All	6	59	59	-	-	1	1142 452
	MP2, w/o High Performance, MD2, All	8	59	59	-	-	1	1859 788
	MP2 w/High Performance, MD2-D500, MD3, All	8	59	59	59	59	1	1944 652
10-03-10	CLIP, Tube, MD2, All	8	59	59	-	-	1	1738 316
10-05-0 OIL GAUGE TUBE OR HOSE								
10-05-7	TUBE, Engine to Oil Gauge Hose, MP1, All	6	59	-	-	-	1	861 543
	MD1, All	6	-	59	-	-	1	861 534
	MD2, MD3, MS1, All	8	-	59	59	-	1	861 540
	MS2, MS3, All	8	-	-	59	59	1	861 541
10-05-10	ELBOW, Engine to Oil Gauge Tube, MD1, All Nipple	6-8	-	59	-	-	1	657 039
		6-8	-	59	-	59	1	694 660
10-05-12	NUT and SLEEVE, Oil Gauge Tube	8	-	59	-	59	1	1319 043
10-05-19	HOSE, Engine to Oil Gauge	8	-	59	-	-	1	1739 240
		8	-	-	-	59	1	1313 643

★ Indicates use as required. Numerals in parentheses () refer to notes. Printed in U.S.A.
 ☐ Indicates parts not listed in any previous parts book. Prices and specifications subject to change without notice.
 * Indicates change or addition. Page 10-1 Feb. 15, 1960 Supersedes Mar. 20, 1959.

1959 PASSENGER CAR PARTS LIST

ENGINE OILING

CODE	PART NAME AND DESCRIPTION	NO. OF CYL.	PLYMOUTH	DODGE	DESOTO	CHRYSLER AND IMPERIAL	PER CAR	PART NUMBER
10-07-0 OIL PUMP								
10-07-2	GASKET and SEAL PACKAGE, MP2 w/High Performance, MD2-D500, MD3, All	8	59	59	59	59	1	2084 355
10-07-3	SHAFT and ROTOR PACKAGE, MP1, MD1, All MP2 w/High Performance, MD2-D500, MD3, All	6	59	59	-	-	1	1316 143
		8	59	59	59	59	1	2084 354
10-07-6	PUMP, Oil, MP1, MD1, All, LHD	6	59	59	-	-	1	1314 607
	MP2 w/o High Performance, MD2, All	8	59	59	-	-	1	1618 949
	MP2 w/High Performance, MD2-D500, MD3.	8	59	59	59	59	1	*2120 870
10-07-7	COVER, MP1, MD1, All	6	59	59	-	-	1	1124 724
	MP2 w/o High Performance, MD2, All	8	59	59	-	-	1	1406 254
10-07-8	GASKET, Cover, MP1, MD1, All	6	59	59	-	-	1	1124 984
	Large, MP2 w/o High Performance, MD2, All	8	59	59	-	-	1	1124 984
	Small, MP2 w/o High Performance, MD2, All	8	59	59	-	-	1	1552 291
	Large, MP2 w/High Performance, MD2-D500, MD3, All	8	59	59	59	59	1	1737 727
10-07-10	BODY, MP1, MD1, All	6	59	59	-	-	1	1314 611
	MP2 w/High Performance, MD2-D500, MD3, All	8	59	59	59	59	1	1737 718
10-07-11	GASKET, Body, MP1, MD1, All	6	59	59	-	-	1	695 442
10-07-12	SEAL, Body, MP2 w/High Performance, MD2-D500, MD3, All	8	59	59	59	59	1	1855 328
10-09-0 OIL PUMP DRIVE SHAFT								
10-09-1	SHAFT, w/Inner ROTOR, MP2 w/o High Performance, MD2, All	8	59	59	-	-	1	1618 950
10-09-5	SHAFT, Oil Pump and Distributor Drive, MP2 w/o High Performance, MD2, All, w/Gear	8	59	59	-	-	1	1323 369
	MP2 w/High Performance, MD2-D500, MD3, All, w/Gear	8	59	59	59	59	1	1739 604
10-09-7	BUSHING, MP2 w/o High Performance, MD2, All	8	59	59	-	-	1	1324 281
	MP2 w/High Performance, MD2-D500, MD3, All	8	59	59	59	59	1	1737 725
10-10-0 OIL PUMP AND DISTRIBUTOR DRIVE GEAR								
10-10-1	GEAR, MP1, MD1, All	6	59	59	-	-	1	601 268
10-10-3	PIN, MP1, MD1, All	6	59	59	-	-	1	1316 559
10-14-0 OIL PUMP ROTOR								
10-14-18	ROTOR, Outer, MP2 w/o High Performance, MD2, All	8	59	59	-	-	1	1324 264
	MP2 w/High Performance, MD2-D500, MD3, All	8	59	59	59	59	1	1737 722
10-14-19	PIN, MD1, MD2, All	6-8	59	59	-	-	1	867 386
10-16-0 OIL PUMP OUTLET PIPE								
10-16-4	PIPE, MP1, MD1, All	6	59	59	-	-	1	1555 519
10-18-0 OIL PUMP SUCTION PIPE								
10-18-4	PIPE, MP1, MD1, AFTER	6	59 (1)	59 (1)	-	-	1	1679 129
10-22-0 OIL PRESSURE RELIEF VALVE								
10-22-11	PLUNGER, MP1, MD1, All	6	59	59	-	-	1	1142 998
	MP2 w/o High Performance, MD2, All	8	59	59	-	-	1	1324 282
	MP2 w/High Performance, MD2-D500, MD3, All UP TO	8	59 (2)	59 (2)	59 (2)	59 (2)	1	1737 741
	MP2 w/High Performance, MD2-D500, MD3, All AFTER	8	59 (2)	59 (2)	59 (2)	59 (2)	1	2120 764

NOTE 1: MP1 Engine No. 3085A, MD1 Engine No. 3088A.

CODE	PART NAME AND DESCRIPTION	NO. OF CYL.	PLYMOUTH	DODGE	DESOTO	CHRYSLER AND IMPERIAL	PER CAR	PART NUMBER
10-22-0 OIL PRESSURE RELIEF VALVE - Cont'd								
10-22-15	SPRING, Std., Green, MP1, MD1, All	6	59	59	-	-	1	*1119 996
	Light, Red, MP1, MD1, All	6	59	59	-	-	1	1119 995
	Medium, Plain, MP1, MD1, All	6	59	59	-	-	1	*1119 994
	Std., Red, MP2 w/o High Performance, MD2, All	8	59	59	-	-	1	1328 352
	Light, Gray, MP2 w/o High Performance, MD2, All	8	59	59	-	-	1	1400 502
	Heavy, Brown, MP2 w/o High Performance, MD2, All	8	59	59	-	-	1	1400 503
	Std., Red, MP2 w/High Performance, MD2-D500, MD3, All	8	59	59	59	59	1	1737 742
	Light, Gray, MP2 w/High Performance, MD2-D500, MD3, All	8	59	59	59	59	1	1737 743
	Heavy, Brown, MP2 w/High Performance, MD2-D500, MD3, All	8	59	59	59	59	1	1737 744
10-22-40	CAP, Plunger, MP1, MD1, All	6	59	59	-	-	1	618 621
	MP2 w/High Performance, MD2-D500, MD3, All	8	59	59	59	59	1	618 621
	MP2 w/o High Performance, MD2, All	8	59	59	-	-	1	*1946 960
10-22-41	GASKET, Cap, MP1, MD1, All	6	59	59	-	-	1	618 622
	MP2 w/High Performance, MD2-D500, MD3, All	8	59	59	59	59	1	618 622
10-23-0 OIL STRAINER								
10-23-7	STRAINER, Includes Suction Pipe, MP1, MD1, All, UP TO	6	59 (1)	59 (1)	-	-	1	1852 178
	MP1, MD1, All, AFTER	6	59 (1)	59 (1)	-	-	1	862 831
	MP2 w/o High Performance, MD2, All	8	59	59	-	-	1	1821 168
	MP2 w/High Performance, MD2-D500, MD3, All	8	59	59	59	59	1	1859 947
10-24-0 OIL PAN								
10-24-1	GASKET SET, MP1, MD1, All	6	59	59	-	-	1	933 438
	MP2 w/o High Performance, MD2, All	8	59	59	-	-	1	1879 520
10-24-2	PLATE and OIL SEAL PACKAGE, Front End, MP1, MD1, All	6	59	59	-	-	1	1115 100
10-24-4	PAN, Complete, MP1, MD1, All	6	59	59	-	-	1	1730 129
	MP2 w/o High Performance, MD2, All, Partial	8	59	59	-	-	1	1828 140
	MP2 w/High Performance, MD2-D500, MD3, All, Partial	8	59	59	59	59	1	1944 694
10-24-6	GASKET, Front and Rear	6	59	59	-	-	2	* 866 680
10-24-8	GASKET, MP2 w/High Performance, MD2-D500, MD3, All	8	59	59	59	59	1	1737 770
10-24-17	SEAL, Front End Oil Seal Plate, MP1, MD1, All	6	59	59	-	-	2	1066 873
10-24-23	SCREW, Pan Attaching	8	59	59	59	59	18	*1947 953
	To Bearing Seal Retainer, MP2 w/High Performance, MD2-D500, MD3	8	59	59	59	59	2	*2121 573
10-24-37	PLUG, Drain, 5/8"-18 x 15/16".	6-8	59	59	59	59	1	1855 247
10-24-38	GASKET, 5/8" L.D. -13/16" O.D.	6	59	59	-	-	1	105 453
	5/8" L.D. -1" O.D.	8	59	59	59	59	1	1855 248
10-26-0 OIL FILTER								
10-26-1	FILTER KIT, Includes Replaceable Cartridge, MP1, MD1, All	6	59	59	-	-	1	1123 152
10-26-2	ADAPTER PACKAGE, use on Cars not equipped with oil Filter, MP1, MD1, All	6	59	59	-	-	1	1450 553

NOTE 1: MP1 Engine No. 3085A,

MD1 Engine No. 3085A.

NOTE 2: MP2 w/High Performance Engine No. 46367,
MS1 Engine No. 18056, MS2 Engine No. 18056,
MC2 Engine No. 20101, MC3 Engine No. 19367,

MD2-D500 Engine No. 46367, MD3 Engine No. 46367,
MS3 Engine No. 18056, MC1 Engine No. 20101,
MY1 Engine No. 19367.

★ Indicates use as required.

Numerals in parentheses () refer to notes.

Printed in U.S.A.

ⓑ Indicates parts not listed in any previous parts book.

Prices and specifications subject to change without notice.

* Indicates change or addition.

1959 PASSENGER CAR PARTS LIST

ENGINE OILING

CODE	PART NAME AND DESCRIPTION	NO. OF CYL.	PLYMOUTH	DODGE	DESOTO	CHRYSLER AND IMPERIAL	PER CAR	PART NUMBER
10-26-0 OIL FILTER Cont'd								
10-26-5	ADAPTER, Base to Filter, MP2 w/High Performance, MD2-D500, MD3, All	8	59	59	59	59	1	1739 619
10-26-6	FILTER, Sealed Can Type	6	59	-	-	-	1	861 028
	MP2 w/High Performance, MD2-D500, MD3, All, w/Built in Gasket	8	59	59	59	59	1	1851 658
10-26-8	CARTRIDGE or ELEMENT, MD1, All	6	59	59	-	-	1	1821 552
	MP2 w/o High Performance, MD2, All LHD.	8	59	59	-	-	1	*1634 447
10-26-12	BASE, MP2 w/High Performance, MD2-D500, MD3	8	59	59	59	59	1	*2120 866
10-26-14	SHELL, w/NUT, SPRING, STUD, MP2 w/o High Performance, MD2, All LHD.	8	59	59	-	-	1	*1557 573
10-26-16	CUP, Seal, w/SPRING, w/Replaceable Cartridge, MP1, MD1, All	6	59	59	-	-	1	1323 883
10-26-26	COVER, use w/Replaceable Cartridge, MP1, MD1, All	6	59	59	-	-	1	1323 881
10-26-27	GASKET, Cover, use w/Replaceable Cartridge, MP1, MD1, All	6	59	59	-	-	1	852 750
	MP2 w/o High Performance, MD2, All LHD.	8	59	59	-	-	1	*1557 575
10-26-28	GASKET, Cover Screw, use w/Replaceable Cartridge, MP1, MD1, All	6	59	59	-	-	1	1323 884
10-26-30	SCREW, Cover, use w/Replaceable Cartridge, MP1, MD1, All	6	59	59	-	-	1	1323 882
10-26-37	GASKET, Spring Retainer, MP2 w/o High Performance, MD2, All LHD.	8	59	59	-	-	1	*1557 584
10-26-49	CLAMP, w/BRACKET, MP1, MD1, All	6	59	59	-	-	1	1320 517
10-26-65	GASKET, Oil Filter Tube Cap, MP2 w/o High Performance, MD2, All LHD., Dom.	8	59	59	-	-	1	1557 581
10-27-0 OIL FILTER TUBES								
NOTE:	Oil Filter Tubes service in 25 foot roll, see Part Type Code 5-53-3, 3/16" size.							
10-27-1	TUBE, Engine to Oil Filter, Replaceable type Cartridge, MP1, MD1, All	6	59	59	-	-	1	861 541

NOTES

★ Indicates use as required. Numerals in parentheses () refer to notes. Printed in U.S.A.
 ☐ Indicates parts not listed in any previous parts book. Prices and specifications subject to change without notice.
 Feb. 15, 1960 Supersedes May 25, 1959. Page 10-4 * Indicates change or addition.