

GROUP 13 - FRAME

PARTS INDICATED BY NAME  
ONLY ARE STANDARD PARTS  
—ORDER BY DESCRIPTION.

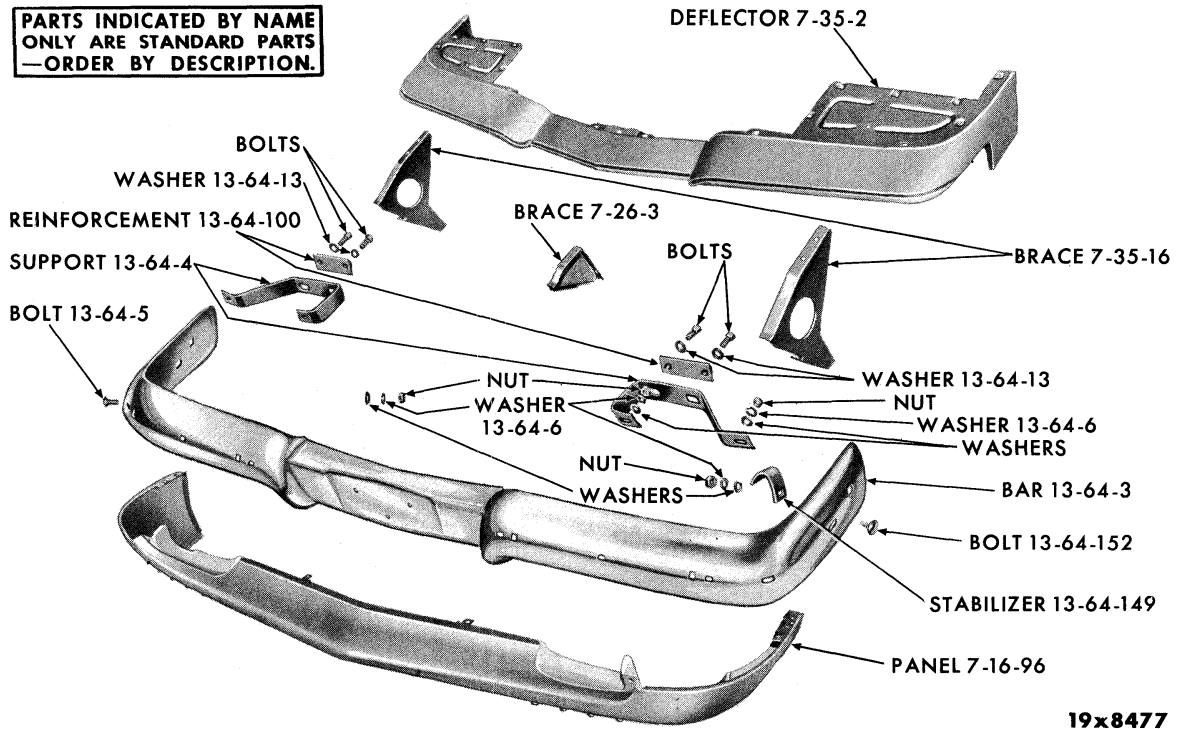

FRONT BUMPER - PLYMOUTH MP1-2

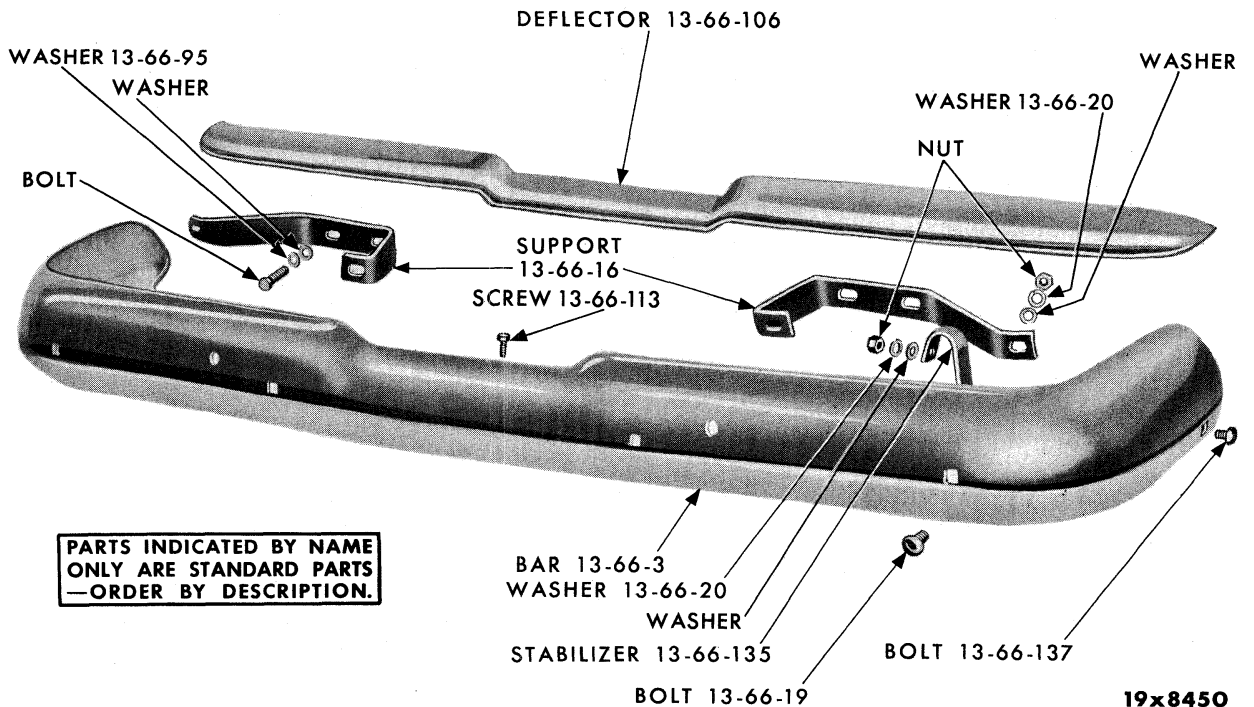

PARTS INDICATED BY NAME  
ONLY ARE STANDARD PARTS  
—ORDER BY DESCRIPTION.

REAR BUMPER - PLYMOUTH MP1-2

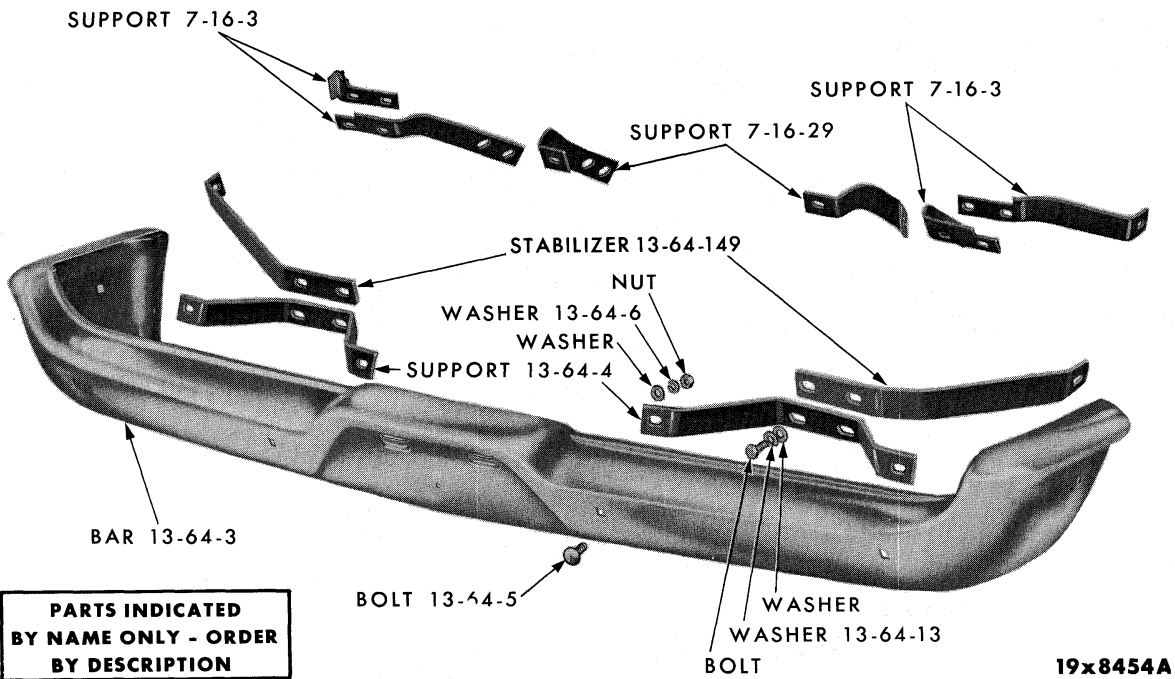

FRONT BUMPER - DODGE MD1-2-3

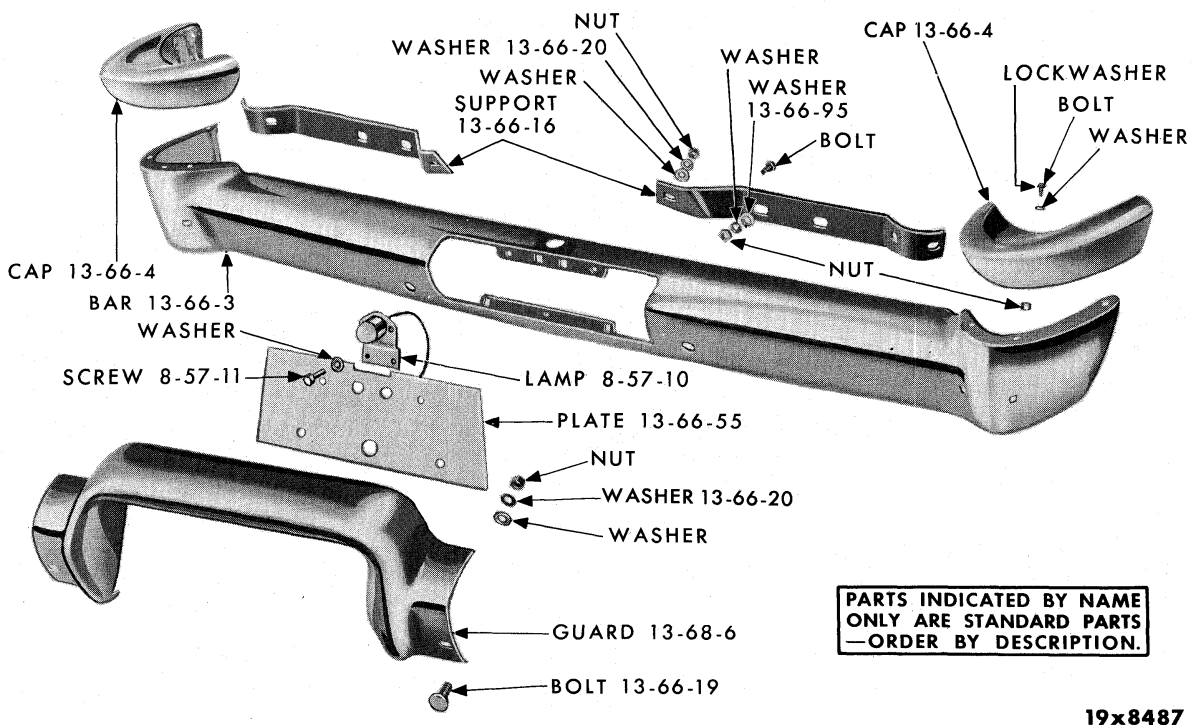

REAR BUMPER - DODGE MD1-2-3

PARTS INDICATED BY NAME  
ONLY ARE STANDARD PARTS  
—ORDER BY DESCRIPTION.

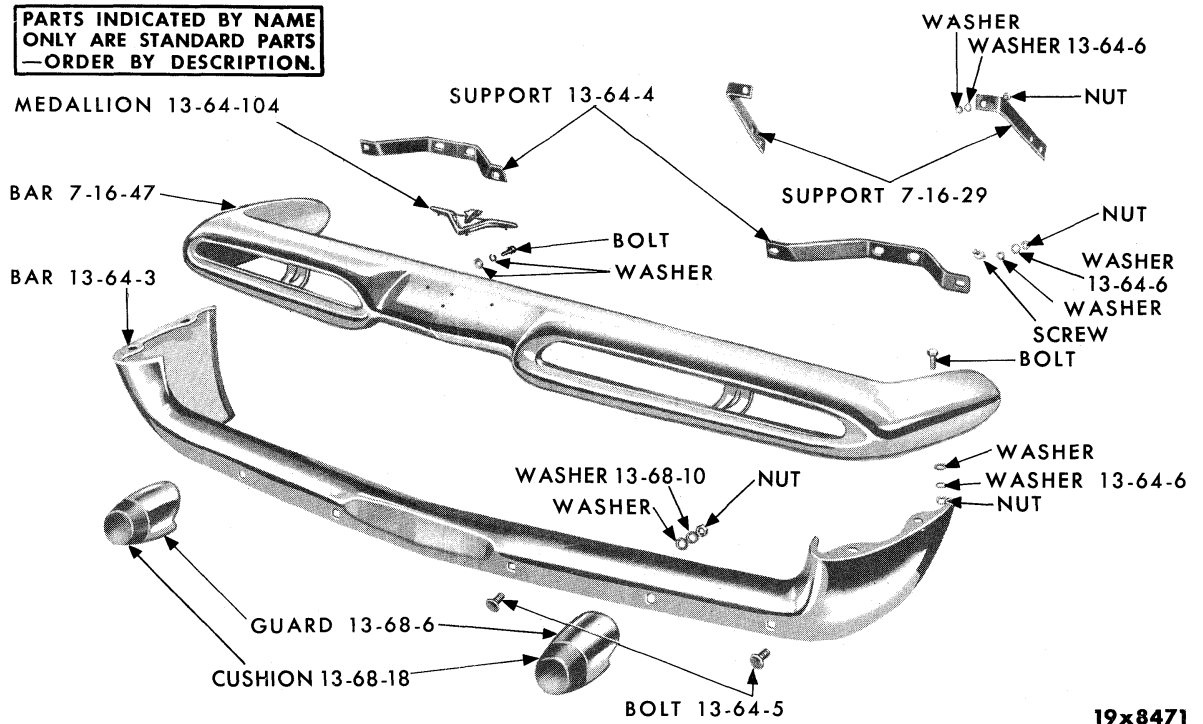

FRONT BUMPER - DESOTO MS1-2-3

PARTS INDICATED BY NAME  
ONLY ARE STANDARD PARTS  
—ORDER BY DESCRIPTION.

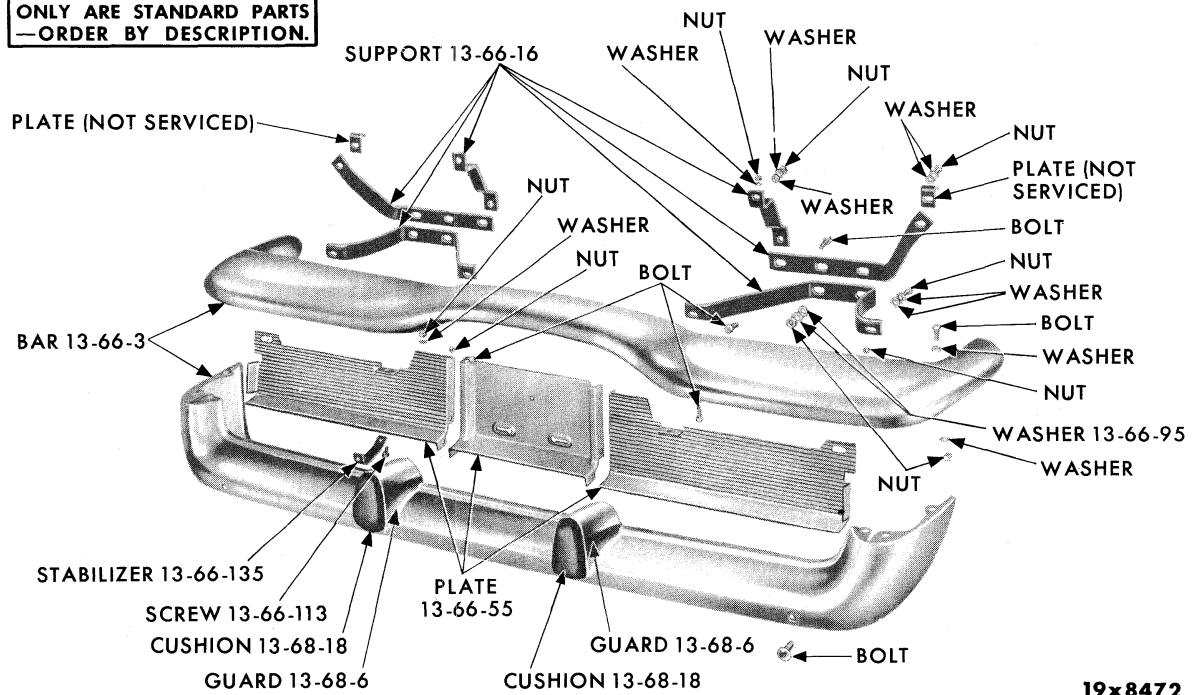

REAR BUMPER - DESOTO MS1-2-3

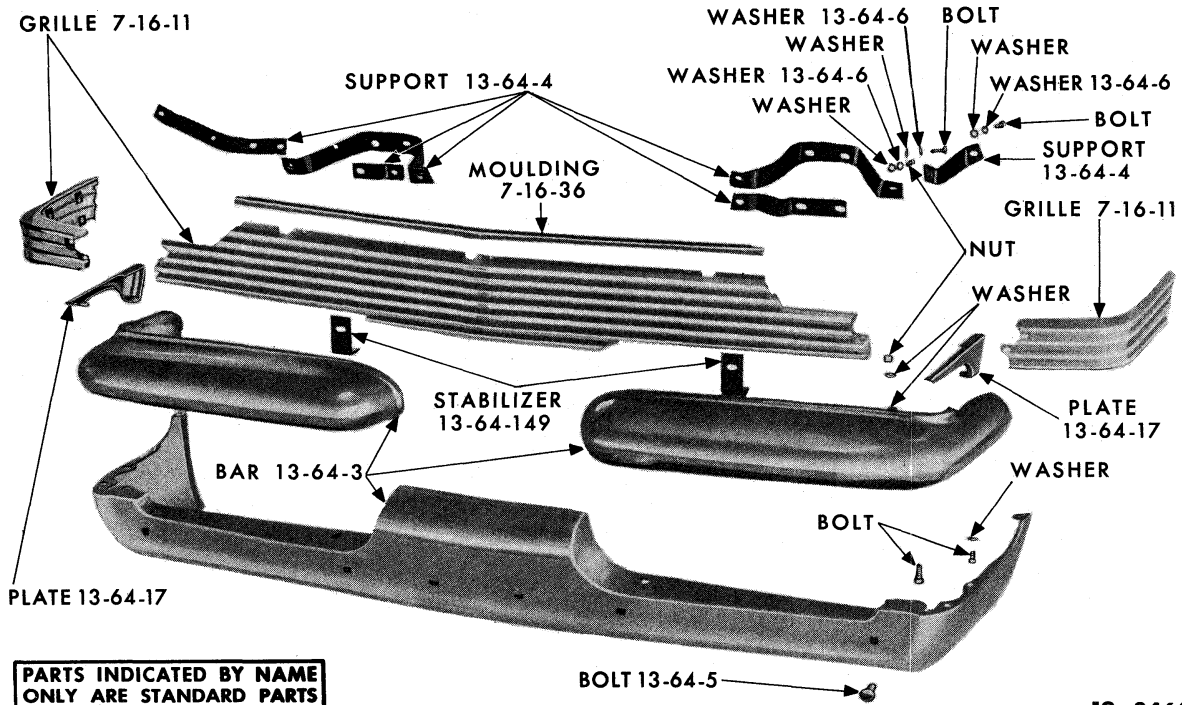

**PARTS INDICATED BY NAME ONLY ARE STANDARD PARTS - ORDER BY DESCRIPTION.**

FRONT BUMPER AND GRILLE - CHRYSLER MC1-2-3

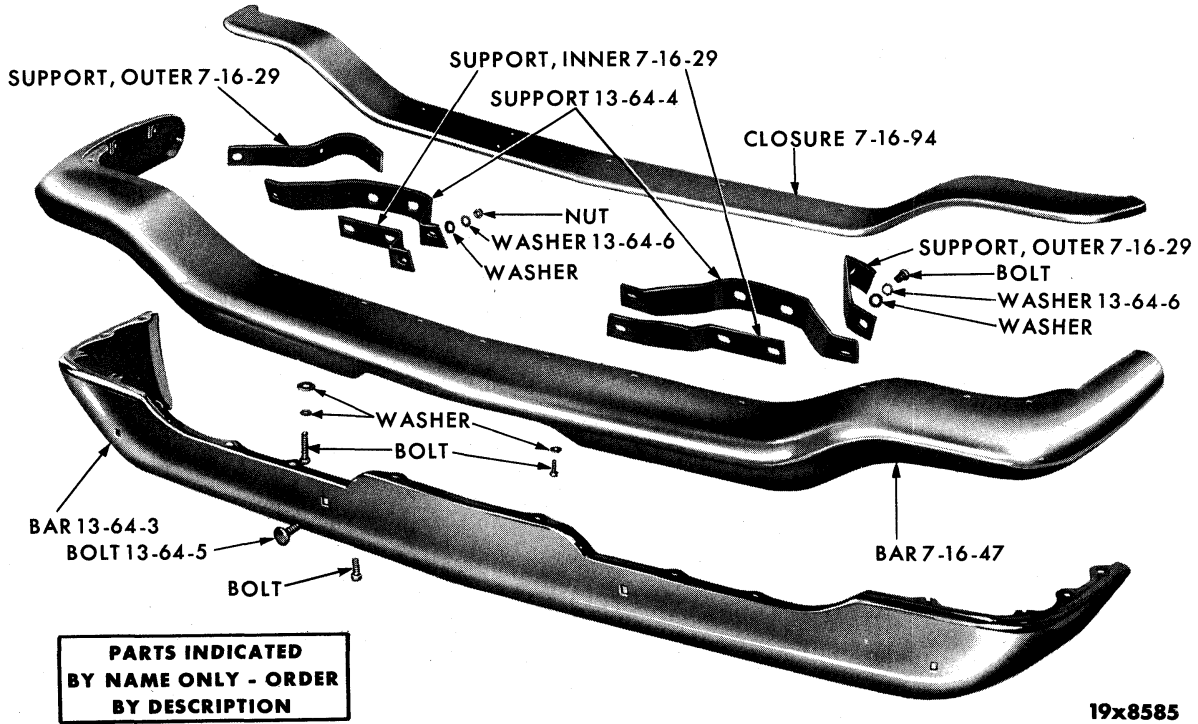

**PARTS INDICATED BY NAME ONLY - ORDER BY DESCRIPTION**

FRONT BUMPER - CHRYSLER MC300E

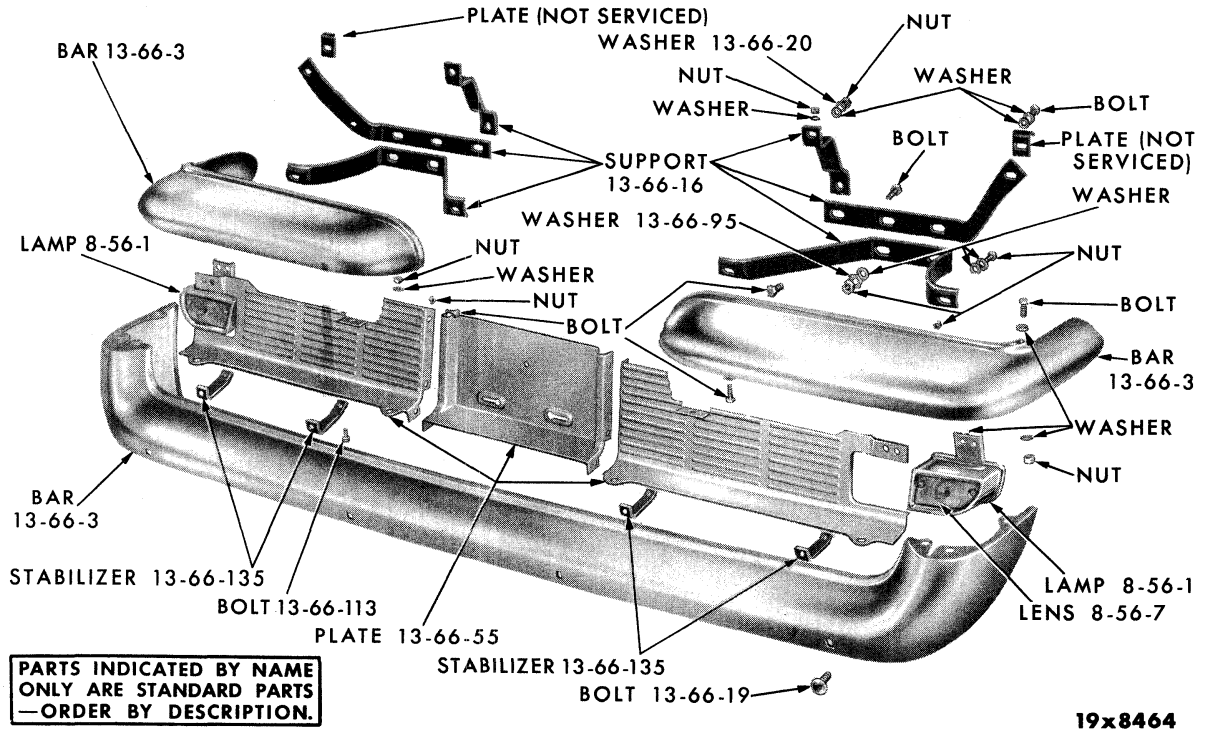

REAR BUMPER - CHRYSLER MC1-2-3 AND MC300E

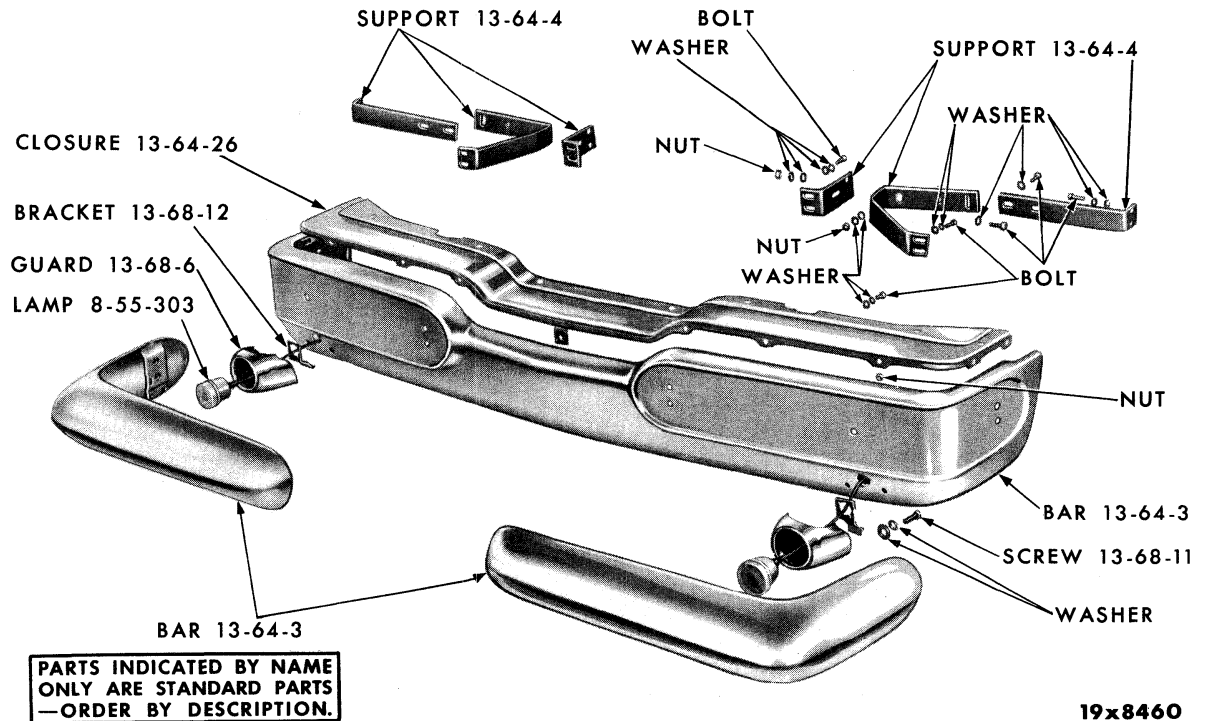

FRONT BUMPER - IMPERIAL MY1



CODE	PART NAME AND DESCRIPTION	NO. OF CYL.	PLYMOUTH	DODGE	DESOTO	CHRYSLER AND IMPERIAL	PER CAR	PART NUMBER
------	---------------------------	-------------	----------	-------	--------	-----------------------	---------	-------------

GROUP 13 - FRAME

<b>13-01-0 FRAME ASSEMBLY</b>								
13-01-1	FRAME, MP1 except Sub. . . . .	6	59	-	-	-	1	1940 944
	MP1 Sub., MD1 . . . . .	6	59	59	-	-	1	1940 947
	MP2 except Cv. Cp. and Sub. . . . .	8	59	-	-	-	1	1940 945
	MP2 Cv. Cp. . . . .	8	59	-	-	-	1	1940 946
	MP2 Sub., MD2, MD3, except Cv.Cp., MS1 Sub., MC1 Sub. . . . .	8	59	59	59	59	1	1940 948
	MD2, MD3 Cv. Cp. . . . .	8	-	59	-	-	1	1940 949
	MS1, MC1, except Cv. Cp. and Sub. . . . .	8	-	-	59	59	1	1940 950
	MS1, MC1, Cv. Cp. . . . .	8	-	-	59	59	1	1940 951
	MS2, MS3, MC2, MC3, except Cv.Cp. and Sub., MC3-300 Sp. Cl. Cp. (also specify 1 each of 1737 374 and 1737 375 Extension) . . .	8	-	-	59	59	1	1851 062
	MS2, MS3, MC3, Cv. Cp., MC3-300 Cv. Cp. (also specify 1 each of 1737 374 and 1737 375 Extension) . . . . .	8	-	-	59	59	1	1851 063
	MS3, MC3, Sub. . . . .	8	-	-	59	59	1	1851 057
	MY1 except Cv. Cp. . . . .	8	-	-	-	59	1	1944 378
	MY1 Cv. Cp. . . . .	8	-	-	-	59	1	1940 307
<b>13-03-0 FRAME FRONT BUMPER SUPPORT</b>								
13-03-21	SUPPORT, Right, MS1, MC1 . . . . .	6-8	59	59	59	59	1	1730 666
	Left, MS1, MC1 . . . . .	6-8	59	59	59	59	1	1730 667
<b>13-11-0 FRAME FRONT CROSSMEMBER</b>								
13-11-5	CROSSMEMBER, No. 1, MS1, MC1. . . . .	6-8	59	59	59	59	1	1674 159
	MS2, MS3, MC2, MC3 . . . . .	8	-	-	59	59	1	⊠1851 054
	MY1 . . . . .	8	-	-	-	59	1	1734 510
	No. 2, w/BRACKETS, MP1 . . . . .	6	59	-	-	-	1	1735 124
	MP2, MS1, MC1 . . . . .	8	59	59	59	59	1	1735 125
	MS2, MS3, MC2, MC3, MY1 . . . . .	8	-	-	59	59	1	⊠1820 938
<b>13-18-0 FRAME REAR CROSSMEMBER</b>								
13-18-4	CROSSMEMBER, except Sub. . . . .	6-8	59	-	-	-	1	1670 952
	Sub. . . . .	6-8	59	-	-	-	1	1820 939
		8	-	59	-	-	1	1675 918
	MS1, MC1 . . . . .	8	-	-	59	59	1	1940 351
	MS2, MS3, MC2, MC3, MY1 . . . . .	8	-	-	59	59	1	1675 915
13-18-31	SEAL, Splash Shield, MS2, MS3, MC2, MC3, MY1, (sold by the foot) . . . . .	8	-	-	59	59	★	1242 974
13-18-32	CLIP, Frame Splash Shield, MS2, MS3, MC2, MC3, MY1 . . . . .	8	-	-	59	59	2	1674 082
<b>13-33-0 BATTERY SUPPORT TRAY</b>								
13-33-61	TRAY, Std. . . . .	6-8	59	59	59	-	1	1612 946
	Heavy Duty . . . . .	6-8	59	59	59	59	1	1633 236
13-33-64	TUBE, Battery Tray Drain, MY1. . . . .	8	-	-	-	59	1	1404 533
<b>13-34-0 BATTERY HOLD-DOWN STRAP</b>								
13-34-3	STRAP . . . . .	6-8	59	59	59	59	1	1828 352
<b>13-35-0 BATTERY HEAT SHIELD</b>								
13-35-1	SHIELD . . . . .	6-8	59	59	59	59	1	1739 055
13-35-6	BRACKET, MC1, MC2, MC3 . . . . .	6-8	59	59	59	59	1	*1739 052

★ Indicates use as required. Numerals in parentheses ( ) refer to notes. Printed in U.S.A.  
 ⊠ Indicates parts not listed in any previous parts book. Prices and specifications subject to change without notice.  
 \* Indicates change or addition. Page 13-1 Feb. 15, 1960 Supersedes Mar. 20, 1959.

# 1959 PASSENGER CAR PARTS LIST

FRAME

CODE	PART NAME AND DESCRIPTION	NO. OF CYL.	PLYMOUTH	DODGE	DESOTO	CHRYSLER AND IMPERIAL	PER CAR	PART NUMBER
<b>13-36-0 BATTERY HOLD-DOWN STUD</b>								
13-36-5	STUD, Inner . . . . .	6-8	59	59	59	59	1	1408 918
	Outer . . . . .	6-8	59	59	59	59	1	1408 915
	Wing Nut . . . . .	6-8	59	59	59	59	2	148 314
<b>13-39-0 FRAME BODY BRACKET</b>								
13-39-1	BRACKET, No. 3, MC1, MC2, MC3 . . . . .	6-8	59	59	59	59	2	1829 945
<b>13-54-0 FRAME REAR SPRING HANGER</b>								
13-54-4	HANGER, Rear Spring, Front, MS1, MC1 . . .	6-8	59	59	59	59	2	1673 469
	MS2, MS3, MC2, MC3 . . . . .	8	-	-	59	59	2	1730 093
	MY1 . . . . .	8	-	-	-	59	2	1734 502
13-54-15	HANGER, Rear Spring Rear, w/BRACKET, Right, MS1, MC1 . . . . .	6-8	59	59	59	59	1	1734 478
	Left, MS1, MC1 . . . . .	6-8	59	59	59	59	1	1734 479
	Right, MS2, MS3, MC2, MC3, except Sub. . .	8	-	-	59	59	1	1829 768
	Left, MS2, MS3, MC2, MC3, except Sub. . .	8	-	-	59	59	1	1829 769
	Right, MS3, MC3, Sub. . . . .	8	-	-	59	59	1	1734 482
	Left, MS3, MC3, Sub. . . . .	8	-	-	59	59	1	1734 483
	w/o Bracket, MS1, MC1 . . . . .	6-8	59	59	59	59	2	1735 126
	MS2, MS3, MC2, MC3 . . . . .	8	-	-	59	59	2	1735 127
	MY1 . . . . .	8	-	-	-	59	2	1735 128
<b>13-64-0 FRONT BUMPER FACE BAR</b>								
13-64-3	BAR, Face, use w/o Strip Guard . . . . .	6-8	59	-	-	-	1	*1828 611
	Use w/Strip Guard . . . . .	6-8	59	-	-	-	1	E1856 158
		8	-	59	-	-	1	1829 065
		8	-	-	59	-	1	1829 022
	Right, Upper, MC1, MC2 . . . . .	8	-	-	-	59	1	1828 626
	Left, Upper, MC1, MC2 . . . . .	8	-	-	-	59	1	1828 627
	Right, Upper, MC3 . . . . .	8	-	-	-	59	1	1829 050
	Left, Upper, MC3 . . . . .	8	-	-	-	59	1	1829 051
	Lower, MC1, MC2, MC3 . . . . .	8	-	-	-	59	1	1828 630
	MC3-300 . . . . .	8	-	-	-	59	1	1676 501
	Right, Impact Bar, MY1 . . . . .	8	-	-	-	59	1	1820 766
	Left, Impact Bar, MY1 . . . . .	8	-	-	-	59	1	1820 063
	Front, MY1 . . . . .	8	-	-	-	59	1	1820 064
13-64-4	SUPPORT, Right . . . . .	6-8	59	-	-	-	1	1829 038
	Left . . . . .	6-8	59	-	-	-	1	1829 039
	Right . . . . .	8	-	59	-	-	1	1856 134
	Left . . . . .	8	-	59	-	-	1	1856 135
	Right, Inner, MS1 . . . . .	8	-	-	59	-	1	1850 824
	Left, Inner, MS1 . . . . .	8	-	-	59	-	1	1850 825
	Right, Outer, MS1 . . . . .	8	-	-	59	-	1	1850 826
	Left, Outer, MS1 . . . . .	8	-	-	59	-	1	1850 827
	Right, MS2, MS3 . . . . .	8	-	-	59	-	1	1851 126
	Left, MS2, MS3 . . . . .	8	-	-	59	-	1	1851 127
	Right, Upper, MC1 . . . . .	8	-	-	-	59	1	1850 810
	Left, Upper, MC1 . . . . .	8	-	-	-	59	1	1850 811
	Right, Lower, Inner, MC1 . . . . .	8	-	-	-	59	1	1850 808
	Left, Lower, Inner, MC1 . . . . .	8	-	-	-	59	1	1850 809
	Right, Lower, Outer, MC1 . . . . .	8	-	-	-	59	1	1850 806
	Left, Lower, Outer, MC1 . . . . .	8	-	-	-	59	1	1850 807
	Right, Upper, MC2, MC3 . . . . .	8	-	-	-	59	1	1851 128
	Left, Upper, MC2, MC3 . . . . .	8	-	-	-	59	1	1851 129
	Right, Upper, Outer, MC2, MC3 . . . . .	8	-	-	-	59	1	1851 130
	Left, Upper, Outer, MC2, MC3 . . . . .	8	-	-	-	59	1	1851 131
	Right, Lower, MC2, MC3 . . . . .	8	-	-	-	59	1	1851 132
	Left, Lower, MC2, MC3 . . . . .	8	-	-	-	59	1	1851 133

★ Indicates use as required.

Numerals in parentheses ( ) refer to notes.

Printed in U.S.A.

E Indicates parts not listed in any previous parts book.

Prices and specifications subject to change without notice.

Dec. 30, 1958 Supersedes Sept. 15, 1958.

\* Indicates change or addition.



CODE	PART NAME AND DESCRIPTION	NO. OF CYL.	PLYMOUTH	DODGE	DESOTO	CHRYSLER AND IMPERIAL	PER CAR	PART NUMBER
<b>13-64-0 FRONT BUMPER FACE BAR Cont'd</b>								
13-64-4	SUPPORT - Cont'd							
	Right, MC3-300 . . . . .	8	-	-	-	59	1	1945 972
	Left, MC3-300 . . . . .	8	-	-	-	59	1	1945 973
	Right, Outer, MY1 . . . . .	8	-	-	-	59	1	1820 754
	Left, Outer, MY1 . . . . .	8	-	-	-	59	1	1820 755
	Right, Outer, Extension, MY1 . . . . .	8	-	-	-	59	1	1820 756
	Left, Outer, Extension, MY1 . . . . .	8	-	-	-	59	1	1820 757
	Inner, MY1 . . . . .	8	-	-	-	59	2	1820 758
13-64-5	BOLT, Face Bar to Support . . . . .	6-8	59	59	59	59	★	1551 097
	SCREW, Closure to Bracket . . . . .	8	-	-	59	-	6	6012 043
13-64-6	WASHER, Bumper Bolt Lock . . . . .	6-8	59	59	59	59	★	1137 795
13-64-10	STUD, Support to Frame . . . . .	8	-	59	-	-	4	1820 114
	MC2, MC3 . . . . .	8	-	-	-	59	2	1856 111
	MC3-300, MY1 . . . . .	8	-	-	-	59	★	1639 477
	Frame Extension to Frame, MC3-300 . . . . .	8	-	-	-	59	4	1737 376
13-64-11	EXTENSION, Frame Front Bumper, Right MC3-300 . . . . .	8	-	-	-	59	1	1737 374
	Left, MC3-300 . . . . .	8	-	-	-	59	1	1737 375
13-64-13	WASHER, Support to Frame, Plain . . . . .	6-8	59	59	59	59	★	1616 746
	Lock . . . . .	6-8	59	59	59	59	★	1943 554
13-64-17	PLATE, Trim, Right, MC1, MC2, MC3 . . . . .	8	-	-	-	59	1	1828 628
	Left, MC1, MC2, MC3 . . . . .	8	-	-	-	59	1	1828 629
13-64-26	CLOSURE, MY1 . . . . .	8	-	-	-	59	1	1943 552
13-64-32	BRACKET, Closure to Grille Bar . . . . .	8	-	-	59	-	6	1829 027
13-64-56	NUT, Support to Frame . . . . .	8	-	59	-	-	4	1325 239
13-64-72	BRACKET, Frame Bumper Support, Right, MY1 Left, MY1 . . . . .	8	-	-	-	59	1	1820 956
	Left, MY1 . . . . .	8	-	-	-	59	1	1820 957
13-64-100	REINFORCEMENT, Support to Frame . . . . .	6-8	59	-	-	-	2	1730 272
13-64-104	MEDALLION, Front Bumper Grille Bar . . . . .	8	-	-	59	-	1	1851 122
13-64-149	STABILIZER, Front Bumper . . . . .	6-8	59	-	-	-	2	1856 118
	Right, Support, UP TO . . . . .	6-8	-	59 (1)	-	-	1	E1945 942
	Left, Support, UP TO . . . . .	6-8	-	59 (1)	-	-	1	E1945 943
	Right, Support, AFTER . . . . .	6-8	-	59 (1)	-	-	1	*1945 970
	Left, Support, AFTER . . . . .	6-8	-	59 (1)	-	-	1	*1945 971
	MC1, MC2, MC3 . . . . .	8	-	-	-	59	2	1856 125
13-64-151	NUT, w/WASHER, Stabilizer to Fender Bolt . . . . .	6-8	59	-	-	-	2	6012 008
13-64-152	BOLT, Bumper to Stabilizer . . . . .	6-8	59	-	-	-	2	1551 098
	8	-	59	-	-	-	2	1551 096
	MC1, MC2, MC3 . . . . .	8	-	-	-	59	2	1551 097
<b>13-66-0 REAR BUMPER FACE BAR</b>								
13-66-3	BAR, Face, except Sub. . . . .	6-8	59	-	-	-	1	1828 606
	Except Sub. . . . .	8	-	59	-	-	1	1943 550
	Upper, except Sub. . . . .	8	-	-	59	-	1	1828 616
	Lower, except Sub., use w/o Cushion Guard . . . . .	8	-	-	59	-	1	1828 617
	Lower, except Sub., use w/Cushion Guard . . . . .	8	-	-	59	-	1	1856 154
	Right, Upper, MC1, MC2, MC3, except Sub. . . . .	8	-	-	-	59	1	1829 044
	Left, Upper, MC1, MC2, MC3, except Sub. . . . .	8	-	-	-	59	1	1829 045
	Lower, MC1, MC2, MC3, except Sub. . . . .	8	-	-	-	59	1	1828 631
	MY1 . . . . .	8	-	-	-	59	1	1828 607
	Right, Extension, MY1 . . . . .	8	-	-	-	59	1	1828 608
	Left, Extension, MY1 . . . . .	8	-	-	-	59	1	1828 609
	Sub., w/o Back-Up Lights . . . . .	6-8	59	-	-	-	1	*1829 031
	w/Back-Up Lights . . . . .	6-8	59	-	-	-	1	1829 066
	MD3, MS1, MS3, MC1, MC3, Sub. . . . .	8	-	59	59	59	1	*1676 518
13-66-4	CAP, Right, except Sub. . . . .	8	-	59	-	-	1	1943 544
	Left, except Sub. . . . .	8	-	59	-	-	1	1943 545
	Right . . . . .	6	-	59	-	-	1	1639 488
	Left . . . . .	6	-	59	-	-	1	1639 489
13-66-12	NUT, Support to Frame, MC1, MC2, MC3, except Sub. . . . .	8	-	-	59	59	2	1325 239
NOTE 1:	MD1 Ser. No. M302-100364 Det. Built.							MD2 Ser. No. M312-102948 Det. Built.
	MD3-M Ser. No. M332-100852 Det. Built.							MD3-H Ser. No. M352-101223 Det. Built.
	MD3-Sub. Ser. No. M372-100887 Det. Built.							

★ Indicates use as required.  
 E Indicates parts not listed in any previous parts book.  
 \* Indicates change or addition.

Numerals in parentheses ( ) refer to notes.

Printed in U.S.A.

Prices and specifications subject to change without notice.

# 1959 PASSENGER CAR PARTS LIST

FRAME

CODE	PART NAME AND DESCRIPTION	NO. OF CYL.	PLYMOUTH	DODGE	DESOTO	CHRYSLER AND IMPERIAL	PER CAR	PART NUMBER
<b>13-66-0 REAR BUMPER FACE BAR Cont'd</b>								
13-66-15	PLUG, Step Plate Bolt Hole, Sub. . . . .	6-8	59	59	59	59	2	6012 060
13-66-16	SUPPORT, Right, except Sub. . . . .	6-8	59	-	-	-	1	1943 536
	Left, except Sub. . . . .	6-8	59	-	-	-	1	1943 537
	Right, except Sub. . . . .	8	-	59	-	-	1	1943 548
	Left, except Sub. . . . .	8	-	59	-	-	1	1943 549
	Right, Lower, except Sub. . . . .	8	-	-	59	-	1	1851 140
	Left, Lower, except Sub. . . . .	8	-	-	59	-	1	1851 141
	Upper, Inner, MC1, MC2, MC3, except Sub. . .	8	-	-	59	59	2	1851 137
	Right, Upper, Outer, MC1, MC2, MC3, except Sub. . . . .	8	-	-	59	59	1	1851 138
	Left, Upper, Outer, MC1, MC2, MC3, except Sub. . . . .	8	-	-	59	59	1	1851 139
	Right, Lower, MC1, MC2, MC3, except Sub. . .	8	-	-	-	59	1	1856 132
	Left, Lower, MC1, MC2, MC3, except Sub. . .	8	-	-	-	59	1	1856 133
	Right, Inner, MY1 . . . . .	8	-	-	-	59	1	1829 054
	Left, Inner, MY1 . . . . .	8	-	-	-	59	1	1829 055
	Right, Outer, MY1 . . . . .	8	-	-	-	59	1	1730 308
	Left, Outer, MY1 . . . . .	8	-	-	-	59	1	1730 309
	Right, Sub. . . . .	6-8	59	59	59	59	1	1828 934
	Left, Sub. . . . .	6-8	59	59	59	59	1	1828 935
13-66-19	BOLT, Bumper to Support, MC1, MC2, MC3 .	6-8	59	59	59	59	4	1551 097
13-66-20	WASHER, Bumper to Support Lock . . . . .	6-8	59	59	59	59	★	1137 795
	WASHER, Step Plate Bolt Hole Plug Spring, Sub.	6-8	59	59	59	59	2	6012 048
13-66-21	REINFORCEMENT, Support to Frame, Sub. . .	6-8	59	-	-	-	2	1737 431
	MS3, MC3, Sub. . . . .	8	-	-	59	59	2	1735 742
	Right, MY1 . . . . .	8	-	-	-	59	1	1828 620
	Left, MY1 . . . . .	8	-	-	-	59	1	1828 621
13-66-55	PLATE, Trim, except Sub. . . . .	8	-	59	-	-	1	1943 553
	Right, MS3 Adventurer . . . . .	8	-	-	59	-	1	1943 556
	Left, MS3 Adventurer . . . . .	8	-	-	59	-	1	1943 557
	Center, MS3 Adventurer . . . . .	8	-	-	59	-	1	1943 555
	Right, except Sub. . . . .	8	-	-	59	-	1	1850 812
	Left, except Sub. . . . .	8	-	-	59	-	1	1850 813
	Center, MC1, MC2, MC3, except Sub. . . . .	8	-	-	59	59	1	1850 814
	Right, MC1, MC2, MC3, except Sub. . . . .	8	-	-	-	59	1	1850 818
	Left, MC1, MC2, MC3, except Sub. . . . .	8	-	-	-	59	1	1850 819
	MY1 . . . . .	8	-	-	-	59	1	1850 823
13-66-56	NUT, Trim Plate to Center Splash Shield, MC1, MC2, MC3, except Sub. . . . .	8	-	-	59	59	2	E6012 063
	Stabilizer to Trim Plate, MC1, MC2, MC3, except Sub. . . . .	8	-	-	59	59	4	*6012 062
	MY1 . . . . .	8	-	-	-	59	12	*6012 050
13-66-93	STUD, Support to Frame, MS3, MC3, Sub. . .	8	-	-	59	59	4	1639 477
13-66-95	WASHER, Support to Frame, Plain . . . . .	6-8	59	59	59	59	★	1616 746
	Lock . . . . .	6-8	59	59	59	59	★	1943 554
13-66-106	DEFLECTOR, Stone, except Sub. . . . .	6-8	59	-	-	-	1	1950 405
	Right, MC1, MC2, MC3, except Sub. . . . .	8	-	-	59	59	1	*1945 930
	Left, MC1, MC2, MC3, except Sub. . . . .	8	-	-	59	59	1	*1945 931
	Center, MC1, MC2, MC3, except Sub. . . . .	8	-	-	59	59	1	*1945 933
13-66-113	SCREW, Trim Plate to Stabilizer, MC1, MC2, MC3, except Sub. . . . .	8	-	-	59	59	4	6000 139
13-66-116	SEAL, Bumper to Deflector, except Sub. . .	6-8	59	-	-	-	1	1954 401
13-66-135	STABILIZER, w/NUT, except Sub. . . . .	6-8	59	-	-	-	2	*1856 113
	Trim Plate to Support, except Sub., MC1, MC2, MC3, AFTER . . . . .	8	-	-	59	59 (1)	4	*1851 143
	Trim Plate to Support, except Sub., MC1, MC2, MC3, UP TO . . . . .	8	-	-	-	59 (1)	4	*1856 131
13-66-136	BRACKET, Stabilizer to Quarter Panel, MY1 .	8	-	-	-	59	2	1730 299
13-66-137	BOLT, Bumper to Stabilizer, except Sub. . .	6-8	59	-	-	-	2	1551 098
	STUD, Bumper to Stabilizer Bracket, except Sub. . . . .	6-8	59	-	-	-	2	1244 141

NOTE 1: MC1 Ser. No. 511-105601, MC2 Ser. No. 531-103031, MC3 Ser. No. 551-103449, Det. Built.

CODE	PART NAME AND DESCRIPTION	NO. OF CYL.	PLYMOUTH	DODGE	DESOTO	CHRYSLER AND IMPERIAL	PER CAR	PART NUMBER
<b>13-66-O REAR BUMPER FACE BAR Cont'd</b>								
13-66-138	NUT, Stabilizer to Quarter Panel Stud, w/WASHER, except Sub. . . . .	6-8	59	-	-	-	2	6012 007
	MY1 . . . . .	8	-	-	-	59	4	6012 050
13-66-146	PLATE, Step, 4 D.Sub. 3 Seater . . . . .	6-8	59	59	59	59	2	1735 666
13-66-147	PAD, Step Plate Tread, 4 D.Sub. 3 Seater . . . . .	6-8	59	59	59	59	2	1735 667
<b>13-68-O BUMPER GUARDS</b>								
13-68-6	GUARD, Front, Right, Wing . . . . .	6-8	59	-	-	-	1	1943 542
	Left, Wing . . . . .	6-8	59	-	-	-	1	1943 543
	Right, Strip. . . . .	6-8	59	-	-	-	1	1856 162
	Left, Strip . . . . .	6-8	59	-	-	-	1	1856 163
	Right . . . . .	8	-	-	59	-	1	1850 830
	Left. . . . .	8	-	-	59	-	1	1850 831
	Right, Wing, MC3 . . . . .	8	-	-	-	59	1	1828 614
	Left, Wing, MC3. . . . .	8	-	-	-	59	1	1828 615
	Right, Parking Light, MY1 . . . . .	8	-	-	-	59	1	1820 742
	Left, Parking Light, MY1 . . . . .	8	-	-	-	59	1	1820 743
	GUARD, Rear, w/o Cushion except Sub. . . . .	6-8	59	-	-	-	2	1829 043
	Used w/Cushion, except Sub. . . . .	6-8	59	-	-	-	2	1851 123
	License Plate, except Sub. . . . .	8	-	59	-	-	1	1941 006
	Except Sub. . . . .	8	-	-	59	-	2	1851 136
	Sub., w/o Back-Up Lights . . . . .	6-8	59	-	-	-	2	1820 777
	w/Back-Up Lights . . . . .	6-8	59	-	-	-	2	1820 770
	MD3 All, MS1, MS3, MC1, MC3, Sub. . . . .	8	-	59	59	59	2	1820 649
13-68-8	BOLT, Bumper Guard . . . . .	8	-	-	59	-	2	660 378
	MC3 . . . . .	6-8	59	-	-	59	★	1551 097
13-68-10	WASHER, Bumper Guard Bolt Lock . . . . .	6-8	59	59	59	59	★	1137 795
13-68-11	SCREW, w/WASHER, Parking Light Guard, MY1 . . . . .	8	-	-	-	59	4	6012 006
13-68-12	BRACKET, Parking Light Guard, Right, MY1 . . . . .	8	-	-	-	59	1	1820 761
	Left, MY1 . . . . .	8	-	-	-	59	1	1820 762
13-68-13	NUT, Parking Light Guard to Bracket Speed, MY1 . . . . .	8	-	-	-	59	4	6012 053
13-68-18	CUSHION, Bumper Guard, Rear, except Sub. . . . .	6-8	59	-	-	-	2	1851 121
	Front . . . . .	8	-	-	59	-	2	1850 815
	Rear, except Sub. . . . .	8	-	-	59	-	2	1851 135
<b>13-72-O BUMPER JACK AND HANDLE</b>								
13-72-1	JACK . . . . .	6-8	59	-	-	-	1	1856 747
	MC1, MC2, MC3 . . . . .	6-8	-	59	-	-	1	1856 750
	MY1 . . . . .	8	-	-	59	59	1	1856 755
	MY1 . . . . .	8	-	-	-	59	1	1856 759
13-72-2	JACK HANDLE, MC1, MC2, MC3 . . . . .	6-8	59	59	59	59	1	1736 990
	MY1 . . . . .	8	-	-	-	59	1	*1737 009

**NOTES**

---



---



---



---



---



---



---



---



---



---

