

**PARTS INDICATED
BY NAME ONLY - ORDER
BY DESCRIPTION**

19x8127C

COOLING SYSTEM - PLYMOUTH MP1

GROUP 7 - COOLING

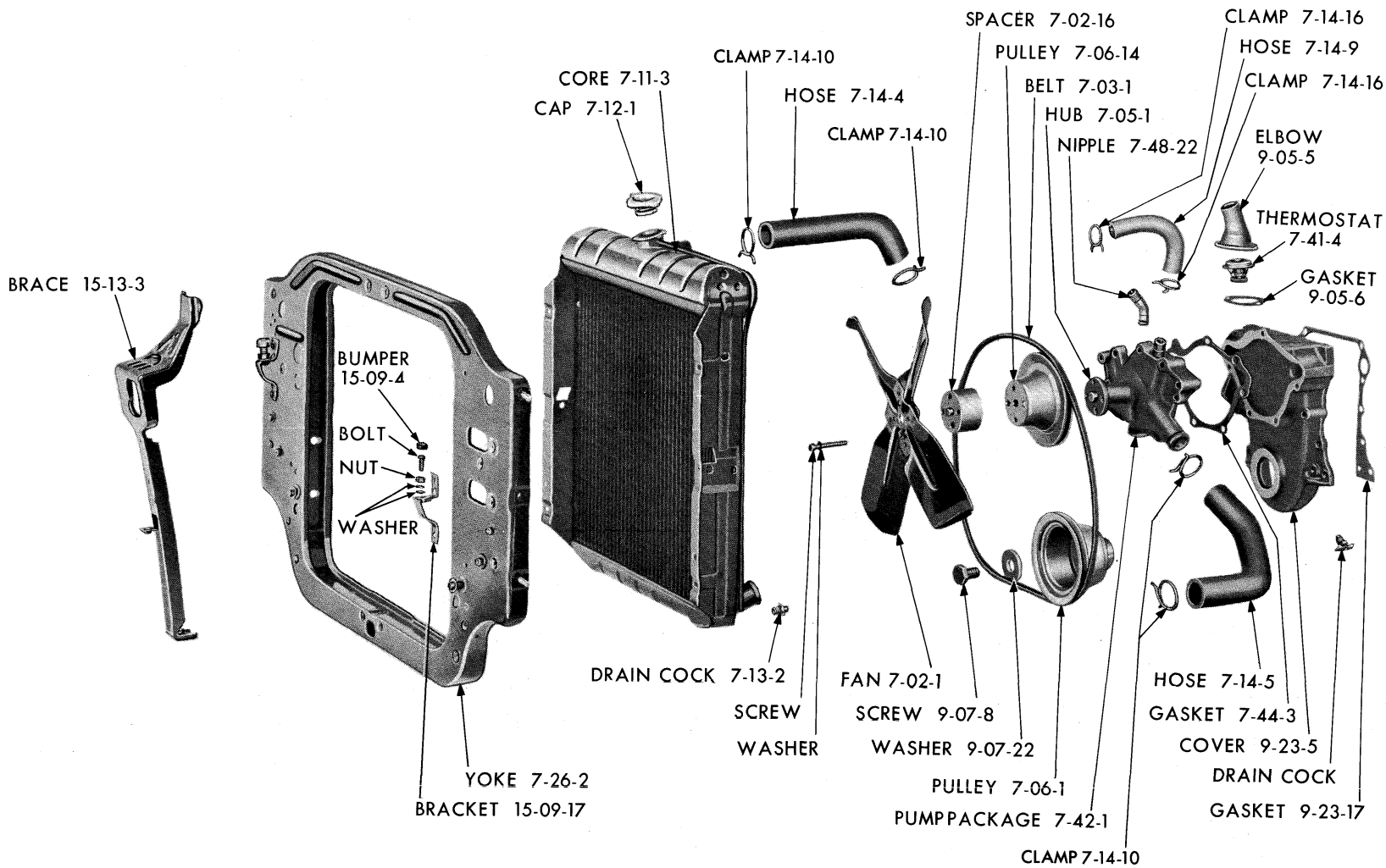

PARTS INDICATED BY NAME
ONLY ARE STANDARD PARTS
—ORDER BY DESCRIPTION.

19X8122B

COOLING SYSTEM - PLYMOUTH MP2

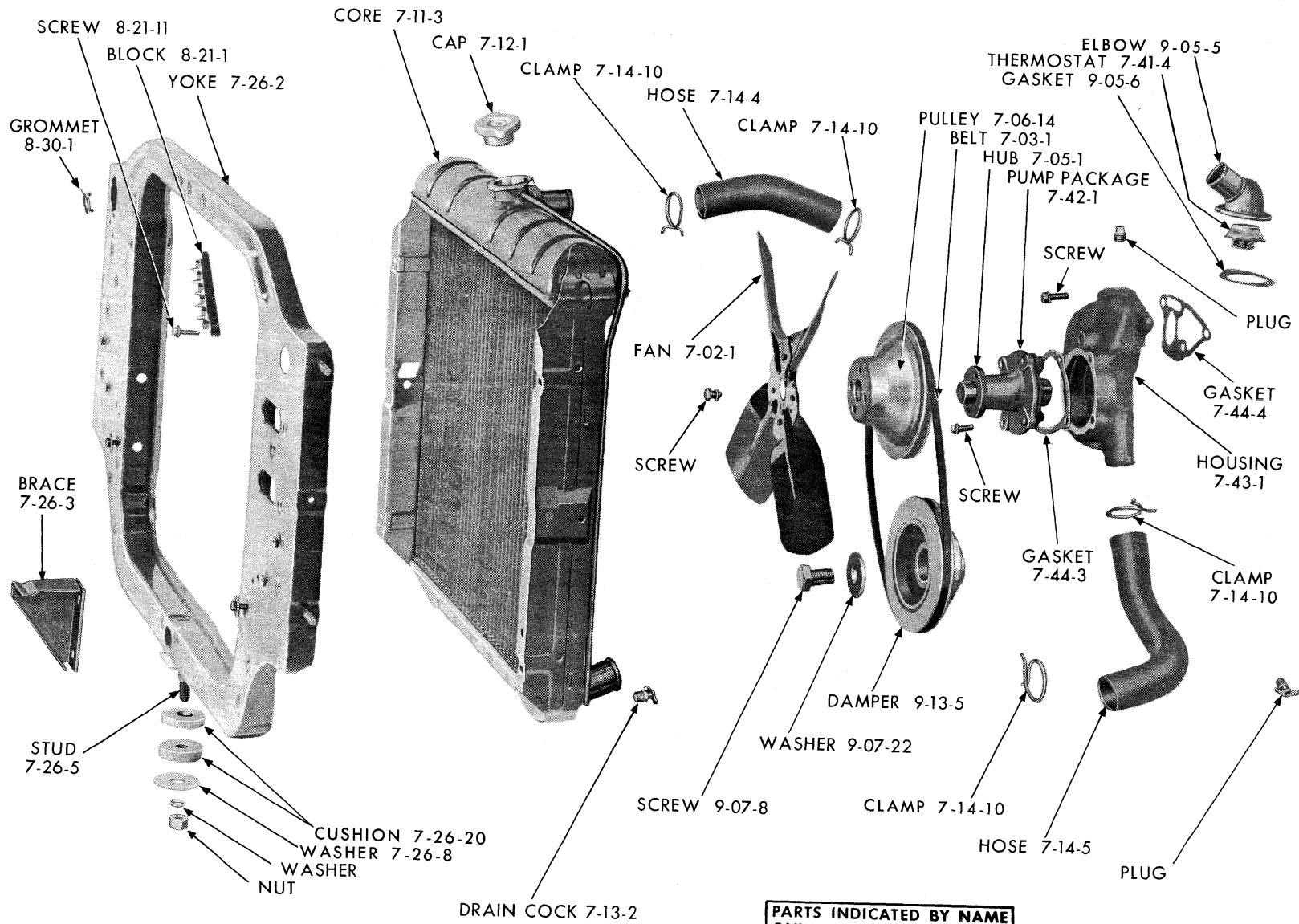

PARTS INDICATED BY NAME
 ONLY ARE STANDARD PARTS
 -ORDER BY DESCRIPTION.

19x8128C

COOLING SYSTEM - DODGE MD1

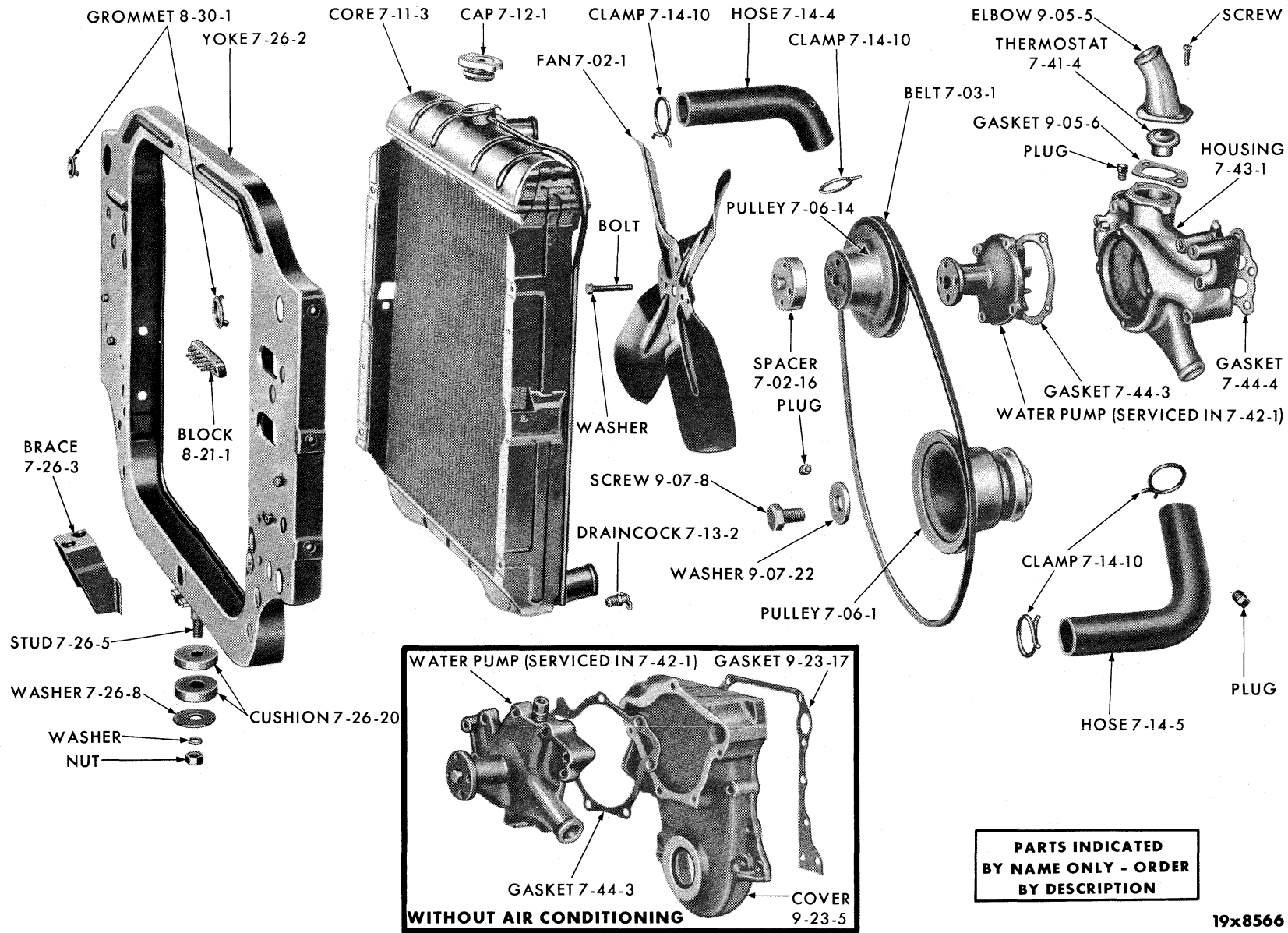

19x8566

COOLING SYSTEM - DODGE MD2

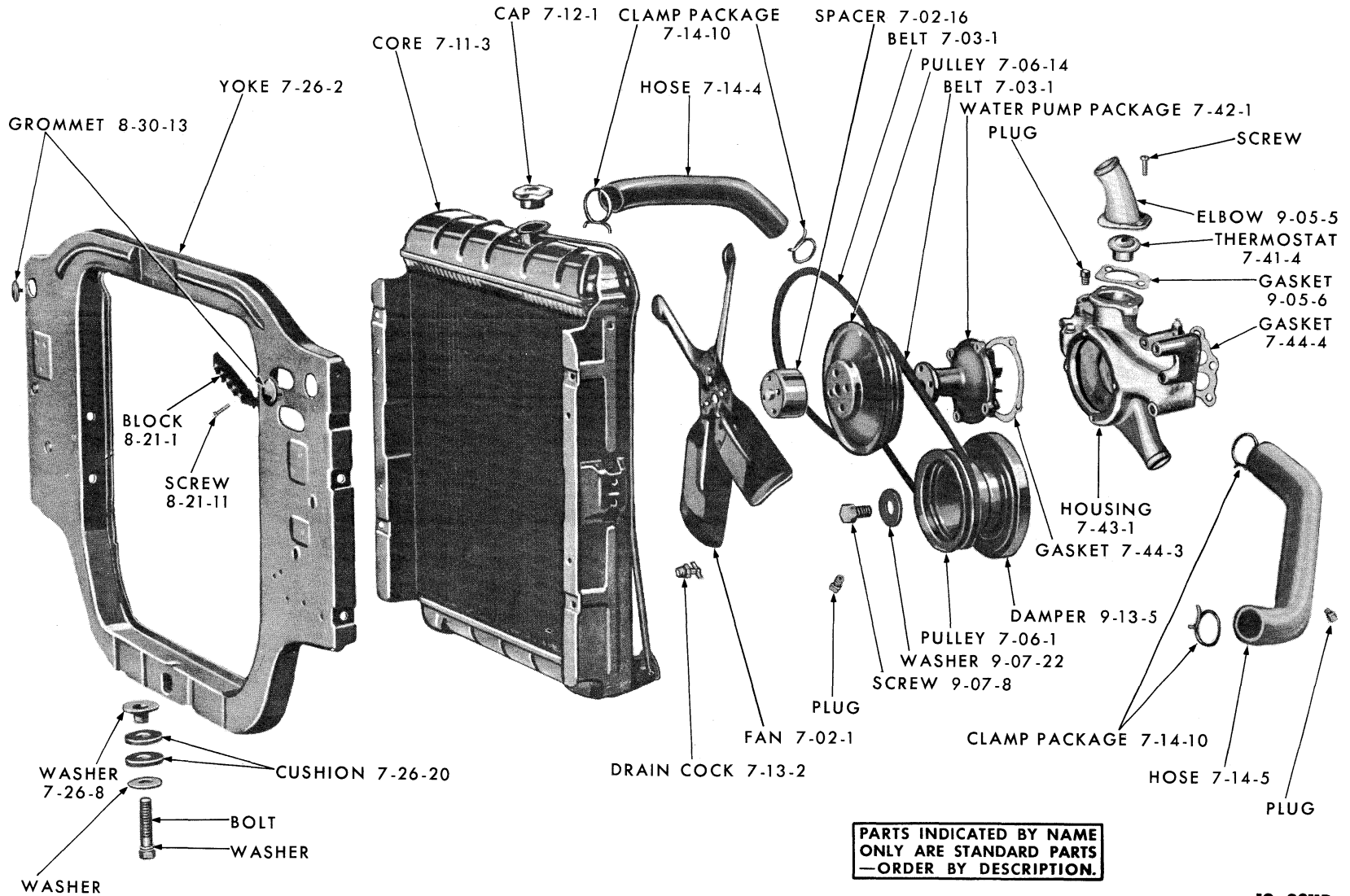

19x8311B

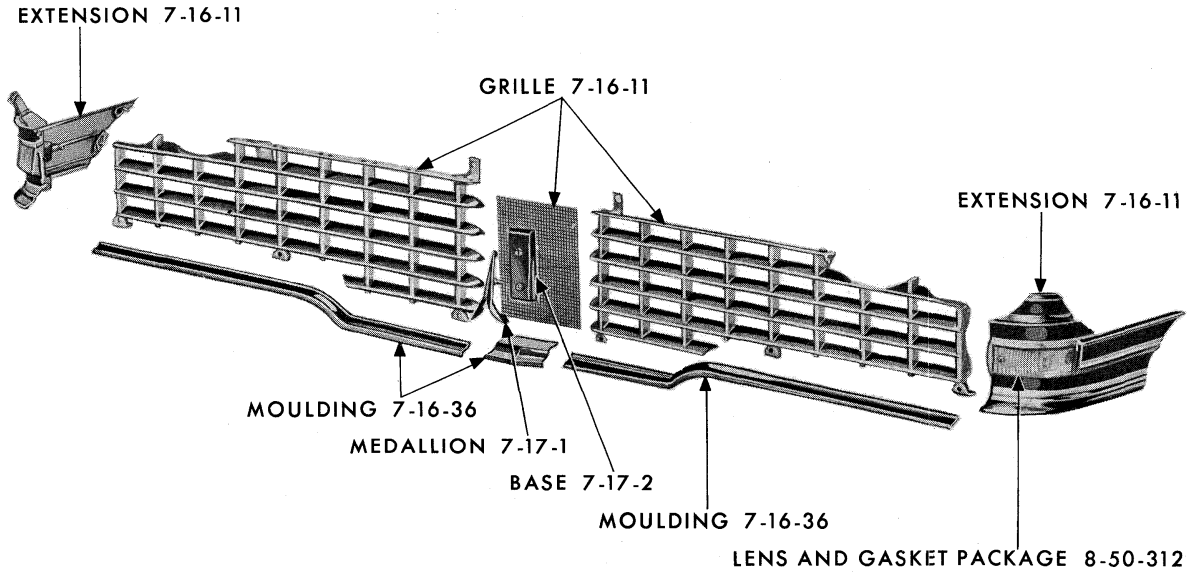

19x8441

GRILLE - PLYMOUTH MP1-2

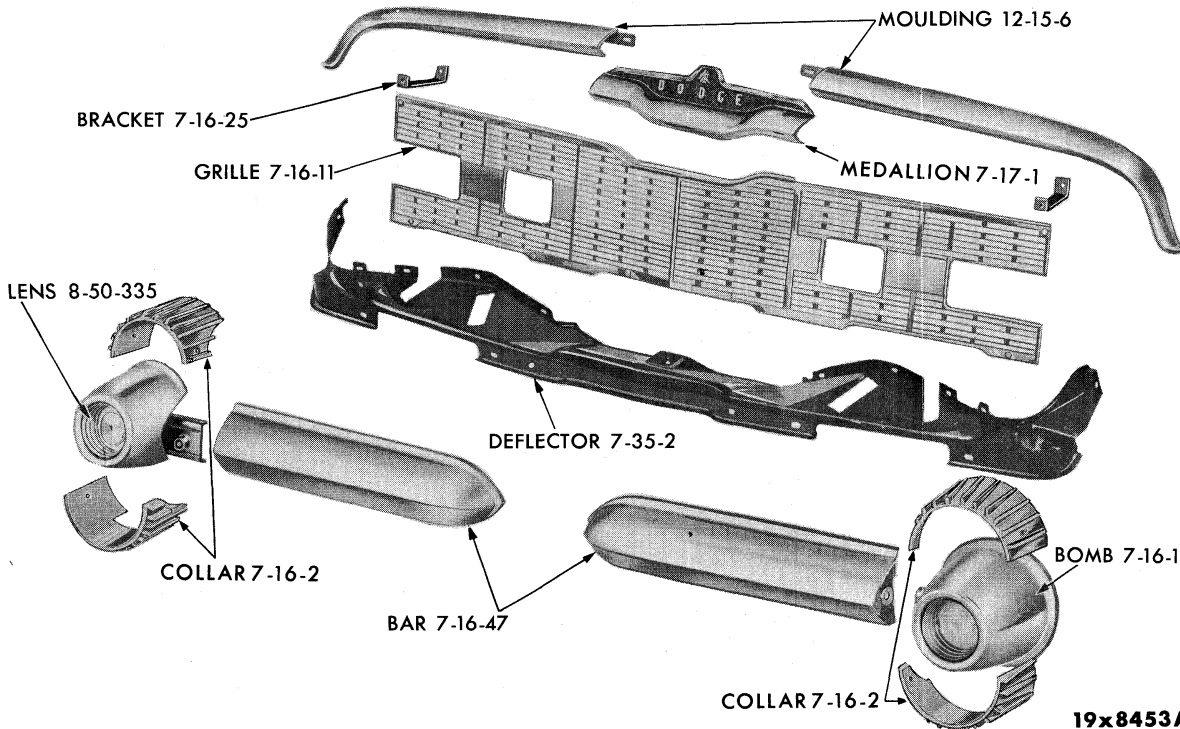

19x8453A

GRILLE - DODGE MD1-2-3

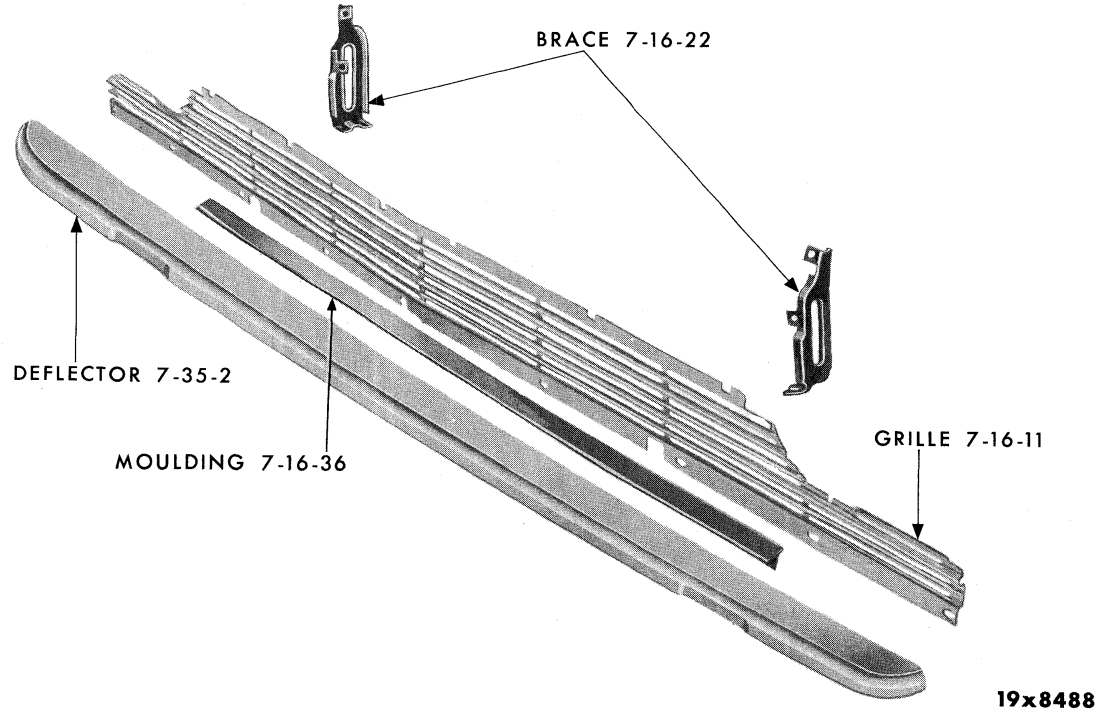

GRILLE - DESOTO MS1-2-3

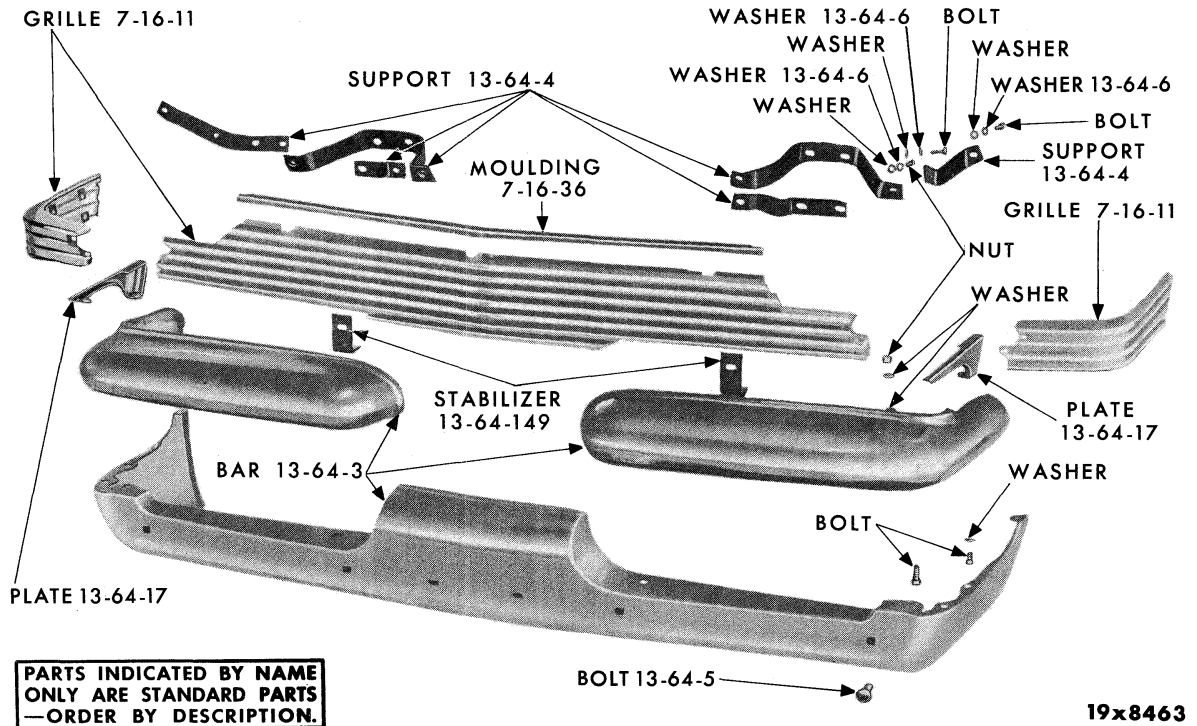

GRILLE AND FRONT BUMPER - CHRYSLER MC1-2-3

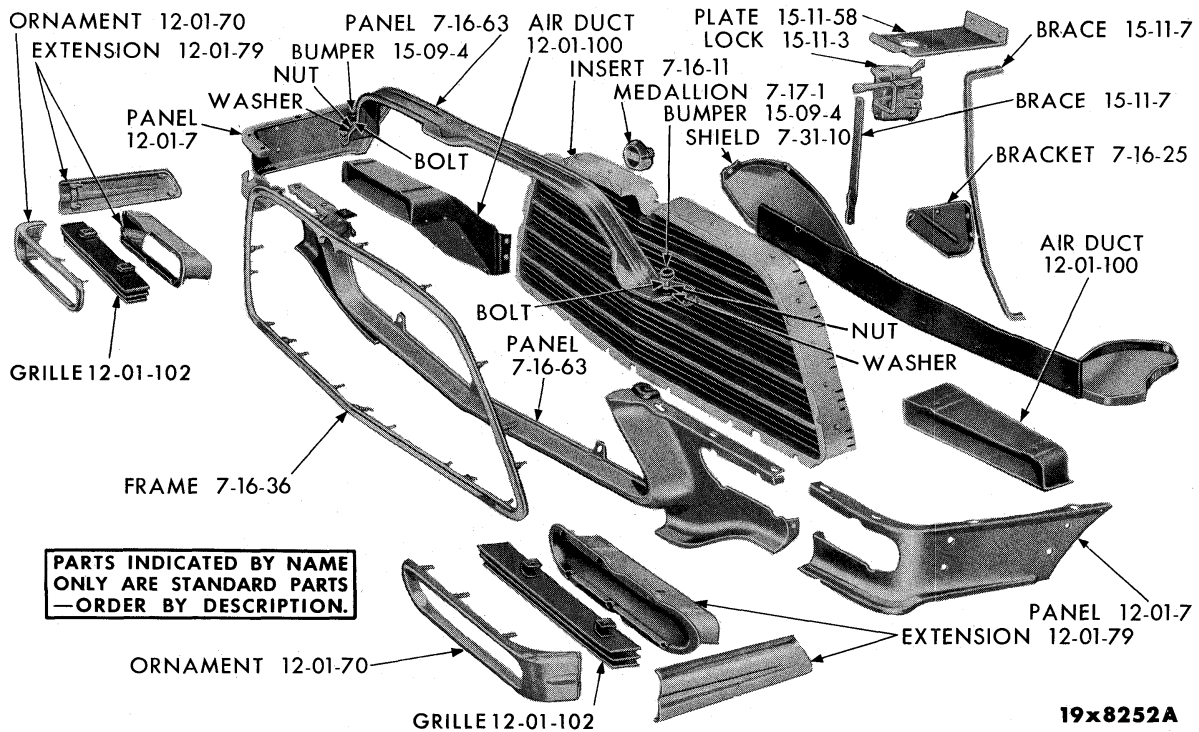

GRILLE - CHRYSLER MC300E

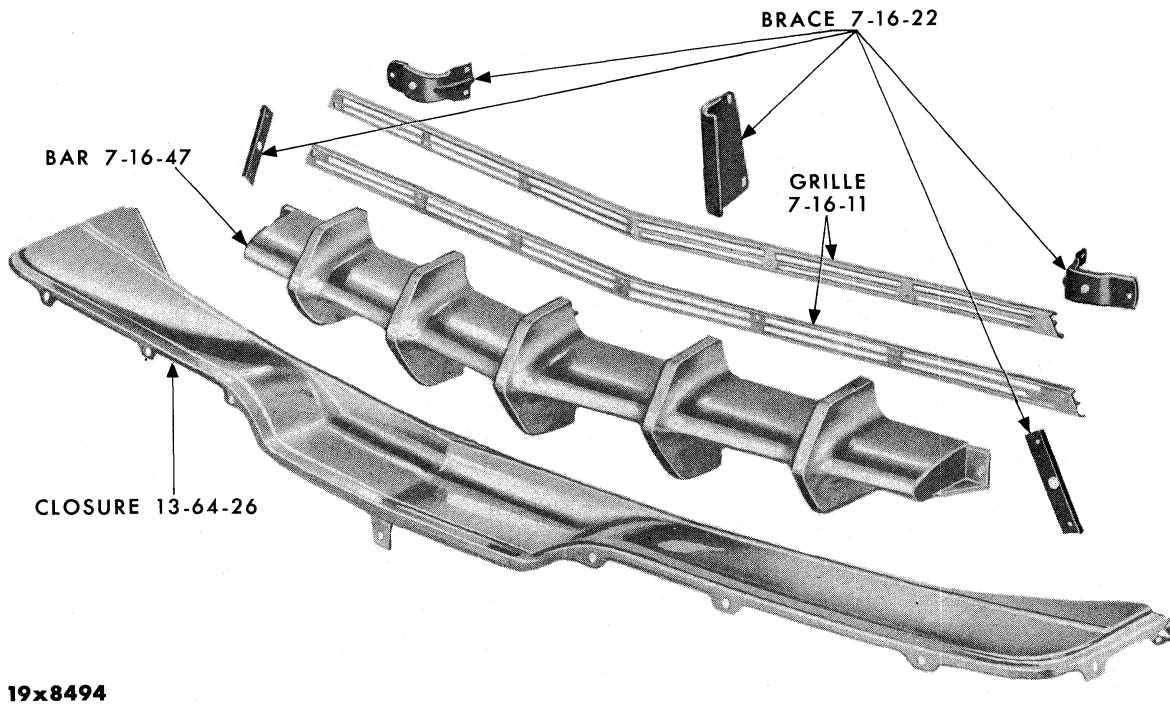

GRILLE - IMPERIAL MY1

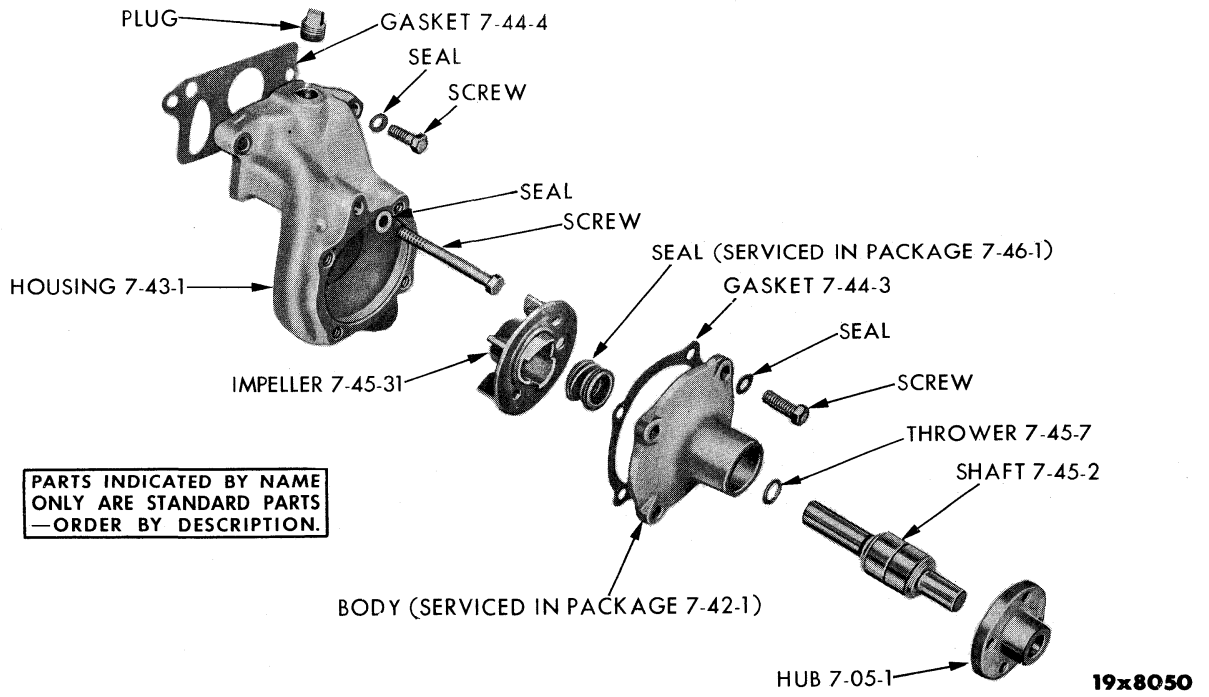

WATER PUMP - 6 CYLINDER

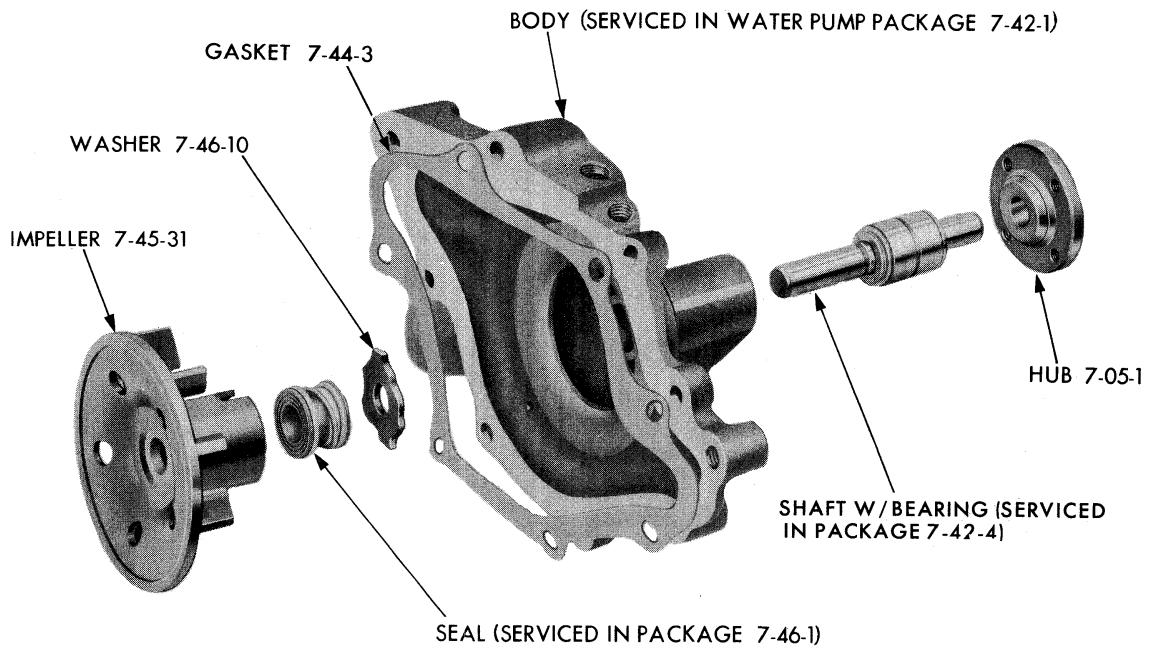

WATER PUMP - PLYMOUTH MP2 (WITHOUT AIR CONDITIONING)

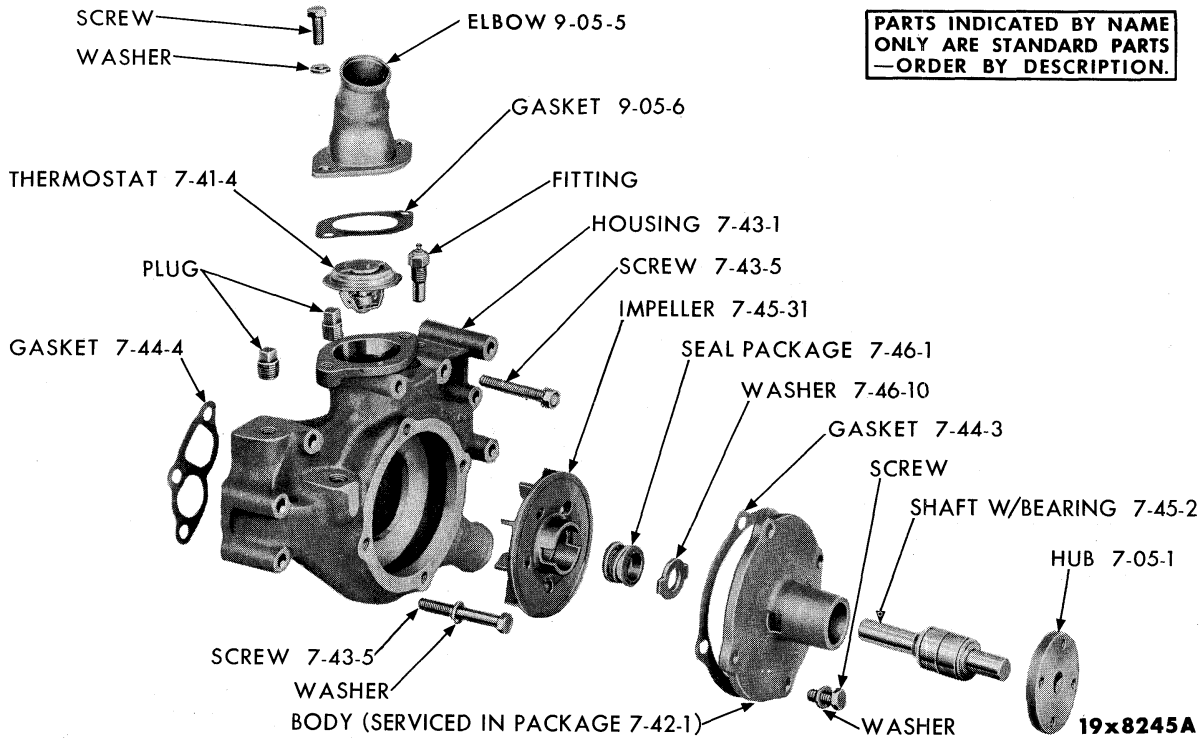

WATER PUMP - V8 CYLINDER (EXCEPT PLYMOUTH MP2) WITHOUT AIR CONDITIONING

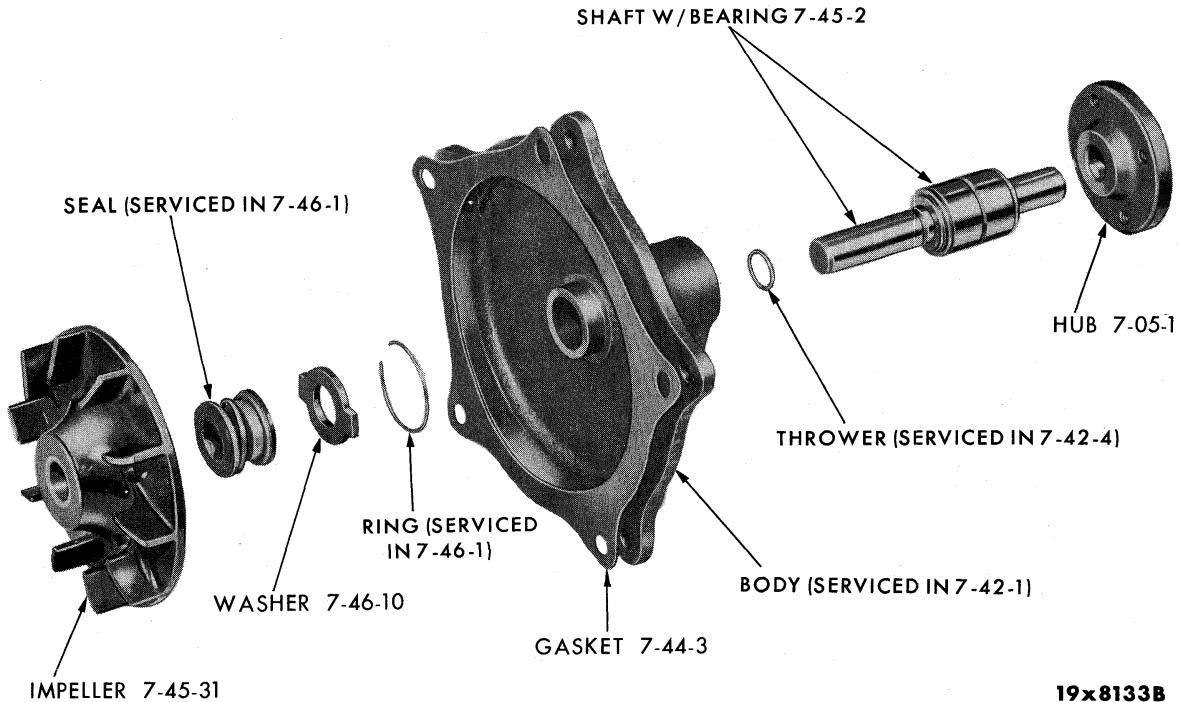

WATER PUMP - V8 CYLINDER (WITH AIR CONDITIONING)

CODE	PART NAME AND DESCRIPTION	NO. OF CYL.	PLYMOUTH	DODGE	DESOTO	CHRYSLER AND IMPERIAL	PER CAR	PART NUMBER
------	---------------------------	-------------	----------	-------	--------	-----------------------	---------	-------------

GROUP 7 - COOLING

7-02-0 FAN ASSEMBLY

7-02-1	FAN, 4 Blade	6	59	59	-	-	1	1732 546
	4 Blade, w/o Air Conditioning	8	59	59	59	59	1	1735 939
	5 Blade, w/Air Conditioning, MS2, MS3, MC2, MC3, MC3-300, MY1, UP TO	8	-	-	59	59 (7)	1	*1851 604
	5 Blade, w/Air Conditioning, MC2, MC3, MC3-300, MY1, AFTER	8	-	-	-	59 (7)	1	1947 303
	6 Blade, w/Air Conditioning, MP2, MD2, MD3, MS1	8	59	59	59	-	1	*1735 941
	7 Blade, w/Air Conditioning, MC1	8	-	-	-	59	1	*2120 223
	6 Blade, w/Air Conditioning, MP2, MD2, High Performance, MD2-D500	8	59	59	-	-	1	1735 941
	MD2, w/Model D Air Conditioning	8	-	59	-	-	1	2120 208
	MD2-D500, MD3, w/Model D Air Conditioning	8	-	59	-	-	1	2120 223
7-02-16	SPACER, Fan, 2" thick, MD2	8	59	59	-	-	1	1825 956
	MP2, MD2, High Performance, MD2-D500, MD3, MS1, 1 3/16" thick	8	59	59	59	-	1	1825 931
	39/64" thick, MD3, MS1	8	-	59	59	-	1	1855 808
	1 3/4" thick, except MS1	8	59	-	59	59	1	1674 746
	w/Air Conditioning, 1" thick, MP2, High Performance, Adventurer, MC3-300	8	59	-	59	59	1	1851 959
	w/Air Conditioning, 1 5/16" thick, MS2, MS3, MC2, MC3, MY1	8	-	-	59	59	1	1851 961

7-03-0 FAN AND RELATED DRIVE BELTS

IMPORTANT: All matched belts should be replaced in sets only.

7-03-1 NOTE: S - Indicates Single Belt. M - Indicates Matched Set.

1959 MODEL WITHOUT POWER STEERING

	Eng. to Fan to Generator	Engine to Fan	Fan to Generator
MP1, MD1	S 1550 179		
MP1, MD1	S 1821 221 (1)		
MP1, MD1	S 1401 624 (2)		
MP2	S 1673 645 (2)		
MP2	See note (8)		
MP2 Fury, MD3, MS1, MS2, MS3	S 1821 138 (1)		
MP2	S 1326 615 (3)		
MP2, MD2		1617 781	1632 586 (5)
MP2, MD2		1617 781	1550 179 (6)
MP2, MD2, Std.	S 1737 927		
MP2, MD2, High Performance	S 1821 138 (1)		
MP2, w/Gas Heater		S 1617 781	S 1401 622
MD3, MS1, MS2, MS3, MC1, MC2	S 1674 677 (3)		
MD2	S 1821 636 (3)		
MP2, MD2-D500, MD2, High Performance	S 1551 007 (4)		
MP2, MD2-D500, MD2, High Performance	S 1674 677 (2)		
MC1, MC2	S 1673 645		
MP2, High Performance, MS1, w/Gas Heater			S 1326 614
MC1, w/Gas Heater			S 1632 586

NOTE 1: w/30 Amp. Low Cut-In or 50 Amp. Bosch Generator.

NOTE 2: w/40 Amp. Generator or Alternator.

NOTE 3: w/40 Amp. Generator.

NOTE 4: w/30 Amp. 4 1/2" Frame Generator.

NOTE 5: w/30 Amp. Low Cut-In or 40 Amp. Generator.

NOTE 6: w/50 Amp. Generator.

NOTE 7: MC2 Serial No. 106 933. MC3 Serial No. 107 489.

MC3-300 Serial No. 100 470. MY1 Serial No. 100 736.

NOTE 8: w/50 Amp. Alternator use 2121 221, w/60 Amp. Alternator use 2121 222.

* Indicates use as required.

Numerals in parentheses () refer to notes.

Printed in U.S.A.

⊠ Indicates parts not listed in any previous parts book.

Prices and specifications subject to change without notice.

* Indicates change or addition.

7-03-O FAN AND RELATED DRIVE BELTS Cont'd

IMPORTANT: All matched belts should be replaced in sets only.

7-03-1 NOTE: S - Indicates Single Belt.

M - Indicates Matched Set.

1959 MODEL WITH POWER STEERING

	Eng. to Fan to Generator	Engine to Fan	Fan to Generator	Eng. to Fan to Strg. Pump	Eng. to Strg. Pump
MP1, MD1			S 1326 615 (1)	S 1737 976	
MP1, MD1			S 1326 615 (2)	S 1737 976	
MP2, MD2	S 1737 927				S 1614 686
MP2, MD2		S 1617 781	S 1632 586 (3)		S 1614 686
MP2, MD2		S 1617 781	S 1550 179 (4)		S 1614 686
MP2, MD2, High Performance	S 1551 007 (5)				S 1827 431
MP2	See Note (6)				S 1614 686
MP2, MD2, High Per- formance, MD3, MS1, MS2, MS3	S 1674 677 (7)				S 1827 431
MP2, MD2, High Per- formance, MD3, MS1, MC1, MC2	S 1821 138 (2)				S 1827 431
MC1, MC2, MC3, MY1	S 1674 677 (7)				S 1827 431
MD3, MS1, MS2, MS3, MC1, MC2, MC3, MY1, Std.	S 1551 007				S 1827 431
MC1, w/Gas Heater			1632 586		
NOTE 1: w/30 Amp., 40 Amp., 50 Amp. Generator.					
NOTE 2: w/30 Amp. Low Cut-In Generator.					
NOTE 3: w/30 Amp. Low Cut-In or 40 Amp. Generator.					
NOTE 4: w/50 Amp. Bosch Generator.					
NOTE 5: w/30 Amp. 4 1/2" Frame Generator.					
NOTE 6: w/50 Amp. Alternator use 2121 221, w/60 Amp. Alternator use 2121 222.					
NOTE 7: w/40 Amp. Generator.					

1959 MODEL WITH AIR CONDITIONING

	Engine to Fan	Engine to Generator to Compressor	Engine to Strg. Pump	Engine to Jackshaft to Compressor	Jackshaft to Generator
MP2, MD2	S 1617 781		S 1827 431	M 1944 881	S 1946 926 (1)
MP2, MD2, High Performance	S 1821 643		S 1827 431	M 1944 881	S 1946 924 (2)
MP2, MD2, High Performance	S 1821 643		S 1827 431	M 1944 881	S 1946 922 (3)
MD2-D500	S 1821 643		S 1827 431	M 1944 881	S 1946 927 (4)
MD3, MS1	S 1821 643		S 1827 431	M 1944 881	S 1946 922 (3)
MD3, MS1	S 1821 643		S 1827 431	M 1944 881	S 1946 924 (2)
MD3, MS1	S 1821 643		S 1827 431	M 1944 881	S 1946 927 (4)
MC1	S 1947 020		S 1827 431	M 1947 132	S 1946 924 (2)
MC1	S 1947 020		S 1827 431	M 1947 132	S 1946 927 (4)
MC1	S 1947 020		S 1827 431	M 1947 132	S 1946 921 (3)
MS2, MS3, MC2, MC3, MY1, MS1, High Performance	S 1821 643	M 1821 912 (5)	S 1827 431 (8)		
MS2, MS3, MC2, MC3, MY1, MS1, High Performance	S 1821 643	M 1947 025 (6)	S 1827 432 (8)		
Adventurer, MC3-300	S 1821 643	M 1821 912 (5)	S 1827 431		
MP2, MD2, MC1, MC2, MC3, MY1	S 1401 633 (7)		1827 431	M 1859 609 (7)	S 1946 921 (7)
NOTE 1: w/4 1/2", 5", 5 1/2" Frame Generator.					
NOTE 2: w/5" Frame Generator.					
NOTE 3: w/4 1/2" Frame Generator.					
NOTE 4: w/5 1/2" Frame Generator.					
NOTE 5: w/30, 35 and 50 Amp. Generator.					
NOTE 6: w/40 Amp. Generator.					
NOTE 7: w/Model D Air Conditioning.					
NOTE 8: MY1 with Air Conditioning, UP TO Approx. Serial No. 100 696 use Part No. 1827 431, from Approx. Serial No. 100 696 to Approx. Serial No. 105 166 use Part No. 1678 280, AFTER Approx. Serial No. 105 166 use Part No. 1827 431.					

★ Indicates use as required.

Numerals in parentheses () refer to notes.

Printed in U.S.A.

Ⓚ Indicates parts not listed in any previous parts book.

Prices and specifications subject to change without notice.

Feb. 15, 1960 Supersedes May 25, 1959.

Page 7-2

* Indicates change or addition.

7-03-0 FAN AND RELATED DRIVE BELTS CONT'D

IMPORTANT: All matched belts should be replaced in sets only.

7-03-1 NOTE: S - Indicates Single Belt.

M - Indicates Matched Set.

1959 MODEL WITH AIR SUSPENSION

	Eng. to Fan to Idler Pulley	Eng. to Gen. to Air Suspension Compressor
MP2, MD2, w/Air Suspension Only	S 1401 633	S 1859 308
MP2, MD2, w/Power Steering	S 1617 781	S 1551 007
MP2, MD2, High Performance, w/o Air Conditioning	S E1947 026	S *1614 013 (1)
MP2, MD2, High Performance, w/o Air Conditioning	S E1947 026	S *1858 607 (2)
MP2, MD2, High Performance, D500, w/Air Conditioning	S 1821 643	
MD3, MS1, MC1, w/o Air Conditioning	S E1947 026	S *1614 013 (1)
MD3, MS1, MC1, w/o Air Conditioning	S E1947 026	S *1858 607 (2)
MD3, MS1, w/Air Conditioning	S 1821 643	
MD3, MS1, w/Air Conditioning	S 1821 643	
MD3, MS1, w/Air Conditioning	S 1821 643	
MC1, w/Air Conditioning	S 1821 643	
MC1, w/Air Conditioning	S 1821 643	
MC1, w/Air Conditioning	S 1821 643	
MS2, MS3, w/o Air Conditioning	S *1558 058	S *1614 013 (1)
MS2, MS3, w/o Air Conditioning	S *1558 058	S *1858 607 (2)
MS2, MS3, w/Air Conditioning	S 1558 058	
MS1, High Performance, MS2, MS3, w/Air Conditioning	S *1558 058	
MC2, MC3, MY1, w/o Air Conditioning	S *1558 058	S *1614 013 (1)
MC2, MC3, MY1, w/o Air Conditioning	S *1558 058	S *1858 607 (2)
MC1, High Performance, MC2, MC3, MY1, w/Air Conditioning	S *1558 058	
MC2, MC3, MY1, w/Air Conditioning	S 1558 058	
Adventurer, MC3-300, w/Air Conditioning	S 1821 643	

NOTE 1: w/4 1/2" and 5" Frame Generator.

NOTE 2: w/5 1/2" Frame Generator.

★ Indicates use as required.

Numerals in parentheses () refer to notes.

Printed in U.S.A.

E Indicates parts not listed in any previous parts book.

Prices and specifications subject to change without notice.

March 20, 1959 Supersedes Nov. 20, 1958.

Page 7-4

* Indicates change or addition.

Eng. to Strg. Pump	Eng. to Air Suspension Compressor	Eng. to Jackshaft to Air Cond. Compressor	Jackshaft to Gen.	Idler Pulley to Air Suspension Compressor	Eng. to Gen. to Air Cond. Compressor
S 1614 686					
S 1827 431					
S 1827 431					
S 1827 431	S 1737 976	M 1944 881	S 1946 927 (2)		
S 1827 431					
S 1827 431					
S 1827 431	S 1737 976	M 1944 881	S 1946 922 (3)		
S 1827 431	S 1737 976	M 1944 881	S 1946 924 (4)		
S 1827 431	S 1737 976	M 1944 881	S 1946 927 (2)		
S 1827 431	S 1737 976	M 1947 132	S 1946 921 (3)		
S 1827 431	S 1737 976	M 1947 132	S 1946 924 (4)		
S 1827 431	S 1737 976	M 1947 132	S 1946 927 (2)		
S 1827 431					
S 1827 431					
S 1827 431				S 1947 023	M 1947 025 (2)
S 1827 431				S 1947 023	M 1821 912 (1)
S 1827 431					
S 1827 431					
S 1827 431				S 1947 023	M 1821 912 (1)
S 1827 431				S 1947 023	M 1947 025 (2)
S 1827 431	S 1737 976	M 1944 881	S 1946 927 (2)		

NOTE 3: w/4 1/2" Frame Generator.

NOTE 4: w/5" Frame Generator.

★ Indicates use as required.

⊠ Indicates parts not listed in any previous parts book.

* Indicates change or addition.

Numerals in parentheses () refer to notes.

Page 7-5

Printed in U.S.A.
Prices and specifications subject to change without notice.

March 20, 1959 Supersedes Nov. 20, 1958.

1959 PASSENGER CAR PARTS LIST

COOLING

CODE	PART NAME AND DESCRIPTION	NO. OF CYL.	PLYMOUTH	DODGE	DESOTO	CHRYSLER AND IMPERIAL	PER CAR	PART NUMBER
7-04-0 FAN AND GENERATOR BELT IDLER PULLEY								
7-04-1	PULLEY, Single Groove	8	59	59	59	59	1	1325 944
	w/Air Conditioning and Air Suspension, MD2	8	59	59	-	-	1	1859 572
	w/Air Conditioning and Air Suspension, MS2, MS3, MC2, MC3, MY1	8	-	-	59	59	1	1859 770
	MC1 w/Gas Heater	8	-	-	-	59	1	1325 944
7-04-5	BRACKET, Pulley, w/Air Conditioning, w/o Air Suspension, MD2	8	59	59	-	-	1	1730 851
	w/Air Suspension, w/o Air Conditioning, MD2 w/30 Amp. Low Cut-In, 40 Amp. and 50 Amp. Generator, w/o Air Conditioning and w/o Air Suspension, MD2	8	59	59	-	-	1	1730 851
	w/Air Conditioning and w/Air Suspension, MD2 w/o Air Conditioning, MD2	8	59	59	-	-	1	1859 571
	w/Air Conditioning, w/or w/o Air Suspension, MP2 High Performance, MD2-D500, MD3, MS1, MC1	8	59	59	59	59	1	1851 401
	w/Air Conditioning, MS2, MS3, MC2, MC3, MY1 MC1 w/Gas Heater	8	-	-	59	59	1	1851 401
	w/Air Suspension, w/o Air Conditioning, MP2 High Performance, MD2-D500, MD3	8	59	59	59	59	1	1854 861
7-04-10	SPACER, Idler Pulley Bracket	8	59	59	59	59	1	1851 608
	Adventurer, MS1, MC1, High Performance, MC3-300	8	-	-	59	59	1	1859 198
	MC1 w/Gas Heater	8	-	-	-	59	1	1947 526
7-04-14	BEARING, Pulley	8	59	59	59	59	1	1330 028
7-04-16	SPACER, Idler Pulley, w/Air Conditioning and Air Suspension, MP2, MD2, MS2, MS3, MC2, MC3, MY1	8	59	59	59	59	1	*2120 520
7-05-0 FAN PULLEY HUB OR WATER PUMP HUB								
7-05-1	HUB	6	59	59	-	-	1	1639 944
	w/Air Conditioning, MP2 High Performance, MD2-D500, MD3, MD3-D500	8	59	59	59	59	1	1634 288
		8	59	59	59	59	1	1947 870
7-06-0 FAN PULLEY								
7-06-1	PULLEY, Fan Drive, w/o Power Steering, Single Groove, 6 1/8" O.D., MD2	8	59	59	-	-	1	*1859 671
	w/Power Steering, Double Groove, 6 5/8" O.D., MD2	8	59	59	-	-	1	*1859 680
	w/o Power Steering, w/o Air Conditioning, Single Groove, 6 5/8" O.D., MP2, MD2, High Performance, MD2-D500, MD3	8	59	59	59	59	1	1821 449
	w/Power Steering, Double Groove, 6 5/8" O.D., MP2, MD2, High Performance, MD2-D500, MD3	8	59	59	59	59	1	1826 053
	w/Air Conditioning, 4 Groove, 7 1/8" O.D., MD2	8	59	59	-	-	1	1859 580
	w/Air Conditioning, 4 Groove, 7" O.D., MP2 High Performance, MS3 Adventurer, MC3-300	8	59	59	59	59	1	1851 253
	w/Air Conditioning, w/o Air Suspension, 4 Groove, 7" O.D., MD3, MS1, MC1	8	-	59	59	59	1	1851 253
	w/Air Conditioning, 4 Groove, 7 1/2" O.D., MS2, MS3, MC1 High Performance, MC2, MC3, MY1	8	-	-	59	59	1	1859 252
	w/Air Suspension, w/o Air Conditioning, 4 Groove, 7 1/8" O.D., MD2	8	59	59	-	-	1	1945 468
	w/Air Suspension, w/Air Conditioning, Double Groove, 6 1/2" O.D., MD2	8	59	59	-	-	1	1855 480
	w/Air Suspension, w/ or w/o Power Steering, 4 Groove, 7 1/8" O.D., MD2	8	59	59	-	-	1	1859 580

★ Indicates use as required.

Numerals in parentheses () refer to notes.

Printed in U.S.A.

Ⓜ Indicates parts not listed in any previous parts book.

Prices and specifications subject to change without notice.

Feb. 15, 1960 Supersedes May 25, 1959.

* Indicates change or addition.

CODE	PART NAME AND DESCRIPTION	NO. OF CYL.	PLYMOUTH	DODGE	DESOTO	CHRYSLER AND IMPERIAL	PER CAR	PART NUMBER
7-06-0 FAN PULLEY Cont'd								
7-06-1	PULLEY - Cont'd							
	w/Air Suspension, w/o Air Conditioning 3 Groove, 6 1/2" O.D. MP2 High Performance, MC1, MC2, MC3	8	59	59	59	59	1	1858 771
	w/Air Suspension, w/Air Conditioning, 5 Groove, 7 1/2" O.D., MP2 High Performance, D500, MD3, MS1, MC1	8	59	59	59	59	1	1859 612
	MP2 High Performance, MS1, MC1, w/Gas Heater	8	59	-	59	59	1	E2120 511
	MP2 High Performance, MS1, MC1, w/Gas Heater, w/Air Suspension	8	59	-	59	59	1	E2120 599
7-06-3	HUB, Fan Drive, w/Air Conditioning, MD2 . .	8	59	59	-	-	1	*1733 805
	w/Air Suspension, MD2	8	59	59	-	-	1	1733 805
7-06-5	SPACER, Fan Drive Pulley, MP2 High Performance, MS1, MC1, w/o Air Suspension . .	8	59	-	59	59	2	1947 030
	w/Air Suspension	8	59	-	59	59	1	1947 030
7-06-14	PULLEY, Fan Driven, w/o Power Steering, Single Groove, 6 7/8" O.D.	6	59	59	-	-	1	1732 600
	w/Power Steering, Double Groove, 7 1/4" O.D. w/or w/o Power Steering, Single Groove, 6 1/2" O.D., MD2 w/ or w/o Gas Heater . . .	6	59	59	-	-	1	1825 949
	8	59	59	-	-	-	1	*1852 582
	w/ or w/o Air Conditioning, Single Groove, 6 1/2" O.D., MD2	8	59	59	-	-	1	1852 582
	w/and w/o Power Steering, Single Groove, 6 7/8" O.D., MP2, MD2, High Performance, D500.	8	59	59	-	-	1	1821 452
	w/Model D Air Conditioning, MP2, MD3 . . .	8	59	59	59	-	1	1981 854
	w/and w/o Power Steering, Single Groove, 6 7/8" O.D., MD3	8	-	59	59	59	1	1821 452
	w/Air Conditioning, Single Groove, 6 1/2" O.D., MD3, MS1, MC1	8	-	59	59	59	1	1851 248
	w/Air Conditioning, Single Groove, 5 3/16" O.D., MS2, MS3, MC2, MC3, MY1	8	-	-	59	59	1	1859 254
	w/Air Conditioning, Single Groove, 5 3/16" O.D., MP2, MD2, High Performance, MD3, MS1, MC1	8	59	59	59	59	1	1947 794
	Adventurer, MC3-300	8	-	-	59	59	1	1851 248
	MP2 High Performance, MS1 MC1, w/Gas Heater	8	59	-	59	59	1	1947 031
7-07-0 FAN DRIVE UNIT								
7-07-1	UNIT, Fan Drive, w/Air Conditioning, MS2, MS3, MC2, MC3, MY1, MC3-300	8	-	-	59	59	1	2084 056
	w/Air Conditioning, MP2 High Performance, MD2-D500, MD3, MD3-D500, MS1, MC1 . . .	8	59	59	59	59	1	1947 799
7-08-0 FAN SHROUD								
7-08-2	SHROUD, Upper, w/Air Conditioning, MS1, MC1	8	59	59	59	59	1	1902 720
	Lower, w/Air Conditioning, MS1, MC1	8	59	59	59	59	1	*1903 600
	Upper, w/Air Conditioning, MS2, MS3, MC2, MC3, MY1	8	-	-	59	59	1	1686 412
	Lower, w/Air Conditioning, MS2, MS3, MC2, MC3, MY1	8	-	-	59	59	1	1686 414
7-08-7	BUMPER, Lower Fan Shroud, w/Air Conditioning, MS1, MC1	8	59	59	59	59	4	1686 455
	w/Air Conditioning, MS2, MS3, MC2, MC3, MY1	8	-	-	59	59	★	1624 506
7-08-13	BRACKET, w/Air Conditioning, MS1, MC1 . .	8	59	59	59	59	4	1902 726
	Right, w/Air Conditioning, MS2, MS3, MC2, MC3, MY1	8	-	-	59	59	1	1686 451
	Left, MS2, MS3, MC2, MC3, MY1	8	-	-	59	59	1	1686 453
7-08-16	NUT, Fan Shroud Bracket, w/Air Conditioning	8	59	59	59	59	4	6010 006

★ Indicates use as required. Numerals in parentheses () refer to notes. Printed in U.S.A.
 □ Indicates parts not listed in any previous parts book. Prices and specifications subject to change without notice.
 * Indicates change or addition. Feb. 15, 1960 Supersedes May 25, 1959.
 Page 7-7

1959 PASSENGER CAR PARTS LIST

COOLING

CODE	PART NAME AND DESCRIPTION	NO. OF CYL.	PLYMOUTH	DODGE	DESOTO	CHRYSLER AND IMPERIAL	PER CAR	PART NUMBER
------	---------------------------	-------------	----------	-------	--------	-----------------------	---------	-------------

7-11-0 RADIATOR CORE

7-11-3 RADIATOR CHART

Year	Model	Standard	Auto. 3 Speed or PowerFlite	High Capacity	w/o Air Conditioning	w/Air Conditioning
1959	MP1, MD1	1832 691	1832 691	1832 691		
1959	MP2, MD2	1832 672	1832 672	1832 693	1832 672	1832 693
1959	MP2 Fury	1832 691	1832 691	1832 298	1832 691	1902 897
1959	MD2-D500		1832 691	1832 298	1832 691	1902 897
1959	MD3, MS1	1832 691	1832 691	1832 298	1832 691	1902 897
1959	MS2, MS3		1832 557	1832 422	1832 557	1832 796
1959	MC1		1832 691	1832 298	1832 691	1902 897

Year	Model	Standard	Auto. 3 Speed or PowerFlite	High Capacity	w/o Air Conditioning	w/Air Conditioning
1959	MC2, MC3, MY1		1832 562	1832 556	1832 562	1832 820
1959	MD2-D500, MD3-D500, MS1, MC1, High Performance					1903 165

7-12-0 RADIATOR FILLER CAP

7-12-1	CAP, 14 lbs. Pressure	6-8	59	59	59	59	1	1541 812
	w/Air Conditioning, 15 lbs. Pressure	8	59	59	59	59	1	1686 107

7-13-0 RADIATOR DRAIN COCK

7-13-2	DRAIN COCK, MS1, MC1	6-8	59	59	59	59	1	1686 198
	MS2, MS3, MC2, MC3, MY1	8	-	-	59	59	1	103 647

7-14-0 RADIATOR HOSE

NOTE: For HEATER HOSE in 50 ft. lengths see Part Type Code 1-48-555.

7-14-4	HOSE, Inlet	6	59	59	-	-	1	1881 804
	w/o Air Conditioning, MD2	8	59	59	-	-	1	*1881 805
	w/Air Conditioning, MD2	8	59	59	-	-	1	1881 813
	w/Air Conditioning, MP2 High Performance, MD2-D500, MD3, MS1, MC1	8	59	59	59	59	1	*1881 804
	w/Air Conditioning, Heavy Duty, MD2	8	59	59	-	-	1	*1881 804
	w/o Air Conditioning, MP2, MD2, High Performance, MD2-D500, MD3, MS1, MC1	8	59	59	59	59	1	*1827 643
	w/Air Suspension, w/o Air Conditioning, MD2, w/o Air Conditioning, MS2, MS3, MC2, MC3, MY1	8	-	-	59	59	1	1827 643
	w/Air Conditioning, MS2, MS3, MC2, MC3, MY1, MC1 High Performance	8	-	-	59	59	1	1852 054
	w/Air Suspension, w/o Air Conditioning, MP2, MD2, High Performance, MD2-D500, MD3, MS1, MC1	8	59	59	59	59	1	*1881 812
	w/Air Suspension, MS2, MS3, MC2, MC3, MY1	8	-	-	59	59	1	1881 805
7-14-5	HOSE, Radiator Outlet, Heavy Duty	6	59	59	-	-	1	1855 794
	Std.	6	59	59	-	-	1	1738 370
	MD2	8	59	59	-	-	1	1858 945
	MP2, MD2, High Performance, MD2-D500, MD3, MS1, MC1	8	59	59	59	59	1	1945 284
	MS2, MS3	8	-	-	59	-	1	1945 284
	MC2, MC3, MY1	8	-	-	-	59	1	*1881 809
7-14-9	HOSE, Water Pump By-Pass, MD2	8	59	59	-	-	1	1730 366
	Fury	8	59	-	-	-	1	1827 686
7-14-10	CLAMP PACKAGE, Radiator Hose, Small, consists of 50 Clamps.	6-8	59	59	59	59	★	1450 499
	Large	6-8	59	59	59	59	★	1450 500

★ Indicates use as required.

Numerals in parentheses () refer to notes.

Printed in U.S.A.

☐ Indicates parts not listed in any previous parts book.
Feb. 15, 1960 Supersedes May 25, 1959.

Prices and specifications subject to change without notice.

* Indicates change or addition.

1959 PASSENGER CAR PARTS LIST

CODE	PART NAME AND DESCRIPTION	NO. OF CYL.	PLYMOUTH	DODGE	DESOTO	CHRYSLER AND IMPERIAL	PER CAR	PART NUMBER
7-16-0 RADIATOR GRILLE								
7-16-1	BOMB, Bumper Grille Bar, Right, MD2, MD3-L, MD3-M	8	-	59	-	-	1	1829 048
	Left, MD2, MD3-L, MD3-M	8	-	59	-	-	1	1829 049
	Right, MD3-H	8	-	59	-	-	1	1829 052
	Left, MD3-H	8	-	59	-	-	1	1829 053
7-16-2	COLLAR, Bumper Grille Bar Bomb. Upper, Right, MD3-H	8	-	59	-	-	1	1948 944
	Upper, Left, MD3-H	8	-	59	-	-	1	1948 945
	Lower, Right, MD3-H	8	-	59	-	-	1	1948 946
	Lower, Left, MD3-H	8	-	59	-	-	1	1948 947
7-16-3	SUPPORT, Front Bumper Bomb, Inner, Right, Inner, Left	8	-	59	-	-	1	1856 140
	Outer, Right	8	-	59	-	-	1	1856 141
	Outer, Left	8	-	59	-	-	1	1856 138
	Outer, Left	8	-	59	-	-	1	1856 139
7-16-10	BUMPER, Radiator Grille Panel	8	-	-	59	59	1	882 875
7-16-11	GRILLE, Right, Dull Finish, Plain	6-8	59	-	-	-	1	1902 602
	Left, Dull Finish, Plain	6-8	59	-	-	-	1	1902 603
	Right, Bright Finish, w/Serrations	6-8	59	-	-	-	1	1903 630
	Left, Bright Finish, w/Serrations	6-8	59	-	-	-	1	1903 631
	Except Adventurer	8	-	-	59	-	1	1832 560
	Adventurer	8	-	-	59	-	1	1902 738
	Upper Rear, MY1	8	-	-	-	59	1	1902 751
	Lower Rear, MY1	8	-	-	-	59	1	1902 752
	Outer, Right, MC1, MC2, MC3	8	-	-	-	59	1	1832 966
	Outer, Left, MC1, MC2, MC3	8	-	-	-	59	1	1832 967
	Center	6-8	59	-	-	-	1	1832 456
	Center, MC1, MC2, MC3	8	-	-	-	59	1	1832 960
	Extension, Right	6-8	59	-	-	-	1	1902 610
	Extension, Left	6-8	59	-	-	-	1	1902 611
	INSERT, w/Extension, MC3-300	8	-	-	-	59	1	1754 129
7-16-12	SCREW, Outer Grille to Fender	8	59	-	-	-	4	1832 241
	Grille Bar to Bomb	8	-	59	-	-	2	1941 003
	BOLT, Bumper Grille to Support	8	-	-	59	-	2	1943 561
	STUD, Grille Bar Center, MY1	8	-	-	-	59	2	1494 093
7-16-19	SPACER, Grille Frame to Extension, MC3-300, Grille Extension Mounting, MY1	8	-	-	-	59	14	6010 136
	Grille Extension Mounting, MY1	8	-	-	-	59	2	1832 832
7-16-22	BRACE, Grille and Grille Panel Bracket to Dust Shield, Right	8	-	-	59	-	1	1832 190
	Left	8	-	-	59	-	1	1832 191
	Right, MC1, MC2, MC3	8	-	-	-	59	1	1832 114
	Left, MC1, MC2, MC3	8	-	-	-	59	1	1832 115
	Upper Grille to Lower Grille, MY1	8	-	-	-	59	2	*1903 581
	Grille to Radiator Side, Painted, MY1	8	-	-	-	59	2	1902 801
	Grille Center, MY1	8	-	-	-	59	1	1902 798
7-16-25	BRACKET, Grille to Yoke	8	-	59	-	-	2	1832 324
	Bumper Grille Bar to Frame, Right, MS1	8	-	-	59	-	1	1850 828
	Left, MS1	8	-	-	59	-	1	1850 829
	Bumper Closure to Grille Bar	8	-	-	59	-	6	1829 027
	Grille Panel to Fender Extension, Right, MC3-300	8	-	-	-	59	1	1686 676
	Left, MC3-300	8	-	-	-	59	1	1686 677
7-16-29	SUPPORT, Bumper Grille Bar, Right	8	-	59	-	-	1	1856 136
	Left	8	-	59	-	-	1	1856 137
	Right, MS2, MS3	8	-	-	59	-	1	1851 124
	Left, MS2, MS3	8	-	-	59	-	1	1851 125
	Inner, Right, MC3-300	8	-	-	-	59	1	1735 740
	Inner, Left, MC3-300	8	-	-	-	59	1	1735 741
	Outer, Right, MC3-300	8	-	-	-	59	1	*1945 972
	Outer, Left, MC3-300	8	-	-	-	59	1	*1945 973
7-16-33	NUT, Grille Upper Bracket to Hood Lock Brace, Grille to Yoke Bracket	6-8	59	-	-	-	1	6010 006
	Grille to Medallion Base Bracket, MC3-300	8	-	59	-	-	2	6010 006
	Grille Bar Lower Spacer, MY1	8	-	-	-	59	2	6010 164
	Grille Bar Lower Spacer, MY1	8	-	-	-	59	2	6010 053
7-16-35	BRACKET, Grille to Hood Lower Lock Brace, MC1, MC2, MC3	8	-	-	-	59	1	1832 109
	Grille Panel to Lock Brace, MC3-300	8	-	-	-	59	1	1624 625

★ Indicates use as required.

☐ Indicates parts not listed in any previous parts book.

* Indicates change or addition.

Numerals in parentheses () refer to notes.

Prices and specifications subject to change without notice.

Feb. 15, 1960 Supersedes May 25, 1959.

1959 PASSENGER CAR PARTS LIST

COOLING

CODE	PART NAME AND DESCRIPTION	NO. OF CYL.	PLYMOUTH	DODGE	DESOTO	CHRYSLER AND IMPERIAL	PER CAR	PART NUMBER
7-16-0 RADIATOR GRILLE Cont'd								
7-16-36	MOULDING, Grille Outer, Upper Right	6-8	59	-	-	-	1	1902 618
	Left	6-8	59	-	-	-	1	1902 619
	Grille Outer	6-8	59	-	-	-	1	1902 617
	Grille, Right	8	-	-	59	-	1	1755 086
	Grille, Left	8	-	-	59	-	1	1755 087
	Grille Panel Upper, w/RETAINER	8	-	-	59	-	1	1903 096
	Grille Panel, MC1, MC2, MC3	8	-	-	-	59	1	1832 928
	Frame, MC3-300	8	-	-	-	59	1	1686 602
7-16-37	CLIP, Upper Outer to Lower Grille	8	-	-	-	59	8	6010 160
	Lower Grille Moulding to Bumper Closure, MY1	8	-	-	-	59	4	6010 176
7-16-45	BRACKET, Grille Lower Moulding Support	6-8	59	-	-	-	6	1902 992
7-16-47	BAR, Bumper Grille, Right	8	-	59	-	-	1	1829 046
	Left	8	-	59	-	-	1	1829 047
		8	-	-	59	-	1	1829 023
	Grille, Vertical, Short, MC3	8	-	-	-	59	6	1902 728
	Long, MC3	8	-	-	-	59	3	1902 710
	Bumper Grille, MC3-300	8	-	-	-	59	1	1676 500
	Grille, MY1	8	-	-	-	59	1	1902 750
7-16-48	J-NUT, Grille Bar to Closure Screw, MC3-300	8	-	-	-	59	5	1730 300
	NUT, Grille Frame Extension to Grille Frame, MC3-300	8	-	-	-	59	2	6010 134
	J-NUT, Grille Bar to Closure Extension Screw, MC3-300	8	-	-	-	59	4	6013 000
7-16-50	WASHER, Grille Bar Support to Frame Bolt Plain, MS2, MS3, MC3-300	8	-	59	59	59	★	1616 746
7-16-57	BOLT, Bumper Grille Bar to Support	8	-	-	59	-	2	1551 766
7-16-58	CLIP, Grille Extension to Fender	6-8	59	-	-	-	4	6010 188
7-16-61	LETTER, Grille Panel, "C", MC1, MC2, MC3	8	-	-	-	59	1	1902 699
	"H"	8	-	-	-	59	1	1902 700
	"R"	8	-	-	-	59	2	1902 701
	"Y"	8	-	-	-	59	1	1902 702
	"S"	8	-	-	-	59	1	1902 703
	"L"	8	-	-	-	59	1	1902 704
	"E"	8	-	-	-	59	1	1902 705
7-16-62	NUT, Name Letters Attaching, MC1, MC2, MC3, MC3-300	8	-	-	-	59	8	E6013 114
7-16-63	PANEL, Grille, MC3-300	8	-	-	-	59	1	1686 669
7-16-65	DOOR, Grille Panel, MC1, MC2, MC3	8	-	-	59	59	1	1832 931
7-16-66	SPRING, Grille Panel Door, MC1, MC2, MC3	8	-	-	59	59	1	1832 134
7-16-70	PIN, Grille Panel Door, MC1, MC2, MC3	8	-	-	59	59	1	1832 135
7-16-75	WASHER, Bumper Grille Bar to Support, MC3-300	8	-	59	-	59	★	1137 795
7-16-89	NUT, w/WASHER, Grille	8	-	59	-	-	2	6010 048
7-16-93	EXTENSION, Grille Bar Closure, Right, MC3-300	8	-	-	-	59	1	1737 408
	Left, MC3-300	8	-	-	-	59	1	1737 409
7-16-94	CLOSURE, Grille Bar, Right	8	-	-	59	-	1	1829 036
	Left	8	-	-	59	-	1	1829 037
	MC3-300	8	-	-	-	59	1	1737 407
7-16-96	PANEL, Grille Air Scoop	6-8	59	-	-	-	1	E1902 634
7-16-97	STUD, Front Ornament to Air Scoop	6-8	59	-	-	-	12	6010 020
7-17-0 RADIATOR GRILLE MEDALLION								
7-17-1	MEDALLION	6-8	59	-	-	-	1	1902 615
		8	-	59	-	-	1	1902 671
	MC3-300, w/BASE and BRACKET	8	-	-	-	59	1	1754 219
7-17-2	BASE, Grille Medallion	6-8	59	-	-	-	1	1902 614
7-26-0 RADIATOR YOKE								
7-26-2	YOKE	6-8	59	-	-	-	1	1832 418
	MS1, MC1	6-8	-	59	59	59	1	1624 717
	MS2, MS3, MC2, MC3	8	-	-	59	59	1	1832 182
	MC3-300	8	-	-	-	59	1	1624 618
	MY1	8	-	-	-	59	1	1863 522
7-26-3	BRACE, Stone Deflector Center	6-8	59	-	-	-	1	1832 454
	Stone Deflector to Yoke	6-8	-	59	-	-	1	1624 864

★ Indicates use as required.

Numerals in parentheses () refer to notes.

Printed in U.S.A.

E Indicates parts not listed in any previous parts book.
Feb. 15, 1960 Supersedes May 25, 1959.

Prices and specifications subject to change without notice.

* Indicates change or addition.

CODE	PART NAME AND DESCRIPTION	NO. OF CYL.	PLYMOUTH	DODGE	DESOTO	CHRYSLER AND IMPERIAL	PER CAR	PART NUMBER
7-26-0 RADIATOR YOKE Cont'd								
7-26-5	SCREW, w/WASHER, Radiator Yoke Reinforcement, w/Air Conditioning, MP2 . . .	8	59	-	-	-	2	6006 218
	Grille Bracket to Yoke	6-8	59	-	-	-	2	6010 016
	Grille to Stone Deflector	6-8	59	-	-	-	6	6010 016
	Grille Center Moulding to Stone Deflector . . .	6-8	-	-	-	-	1	6010 016
	Grille Upper Bracket to Hood Lock Striker Brace	6-8	59	-	-	-	2	6010 016
	Stud, Yoke to Frame	6-8	59	59	59	59	1	6010 026
7-26-7	REINFORCEMENT, Yoke Horn, w/Air Conditioning, MP2	8	59	-	-	-	1	1754 666
	Frame to Yoke, Right, MY1	8	-	-	-	59	1	1851 038
	Left, MY1	8	-	-	-	59	1	1851 039
7-26-8	WASHER, Yoke to Frame, except MY1	6-8	59	59	59	59	★	6010 042
	MY1	8	-	-	-	59	★	6010 100
7-26-9	SEAL, Yoke Air Shield to Hood, MS2, MS3, MC2, MC3, MY1, (sold by the foot)	8	-	-	59	59	★	1242 974
	w/Model D Air Conditioning	6-8	59	59	59	59	1	1985 512
7-26-11	NUT, Yoke Reinforcement, w/Air Conditioning, MP2	8	59	-	-	-	2	6010 048
	Lower Dust Shield to Yoke, MY1	8	-	-	-	59	1	6006 126
7-26-15	SHIELD, Yoke to Core, MS2, MS3, MC2, MC3, MY1	8	-	-	59	59	2	1754 736
7-26-17	CLIP, Yoke to Core Air Shield, MS2, MS3, MC2, MC3, MY1	8	-	-	59	59	8	6010 060
7-26-18	SHIM, Yoke to Frame	6-8	59	59	59	59	★	6010 025
7-26-20	CUSHION, Yoke to Frame	6-8	59	59	59	59	★	6010 027
7-26-23	SLEEVE, Yoke to Frame	8	-	-	59	59	★	6010 139
7-26-27	BRACKET, Grille to Yoke	6-8	59	-	-	-	1	1832 189
7-26-28	REINFORCEMENT, Yoke to Frame, Right, MY1	8	-	-	-	59	1	1851 038
	Left, MY1	8	-	-	-	59	1	1851 039
7-31-0 RADIATOR SHIELD								
7-31-2	SEAL, Radiator Dust Shield to Front Bumper, w/Air Conditioning, MC1	8	-	-	-	59	1	E1903 790
	MY1	8	-	-	-	59	1	E1903 879
7-31-10	SHIELD, Dust, MS1, MC1	8	-	-	59	59	1	1832 722
	w/BAFFLE, MS2, MS3, MC2, MC3	8	-	-	59	59	1	1832 923
	MC3-300	8	-	-	-	59	1	1754 197
	MY1	8	-	-	-	59	1	1832 576
7-31-43	SEAL, Dust Shield to Front Bumper, (sold by the foot) MC3-300	8	-	-	-	59	★	1242 974
7-33-0 RADIATOR UPPER CROSS BAR								
7-33-1	BAR, MY1	8	-	-	-	59	1	1686 473
	MC3-300	8	-	59	-	-	1	1832 544
	MC3-300	8	-	-	-	59	1	1686 648
7-35-0 RADIATOR STONE DEFLECTOR								
7-35-2	DEFLECTOR	8	-	-	59	-	1	1832 850
		6-8	59	-	-	-	1	1832 450
		8	-	59	-	-	1	1832 523
7-35-12	SCREW, Stone Deflector to Yoke, w/WASHER, MD2, MD3	8	-	59	-	-	4	*6000 160
7-35-13	J-NUT, Grille Center Moulding to Stone Deflector	6-8	59	-	-	-	1	6010 006
	Grille to Stone Deflector	6-8	59	-	-	-	6	6010 006
7-35-16	BRACE, Radiator Stone Deflector to Air Scoop	6-8	59	-	-	-	2	1755 067
7-41-0 THERMOSTAT								
7-41-4	THERMOSTAT, 160° F.	6-8	59	59	59	59	1	1734 957
	180° F.	6	59	59	-	-	1	1735 011
	180° F.	8	59	59	59	59	1	1674 602

★ Indicates use as required.

E Indicates parts not listed in any previous parts book.

* Indicates change or addition.

Numerals in parentheses () refer to notes.

Printed in U.S.A.

Prices and specifications subject to change without notice.

Feb. 15, 1960 Supersedes May 25, 1959.

1959 PASSENGER CAR PARTS LIST

COOLING

CODE	PART NAME AND DESCRIPTION	NO. OF CYL.	PLYMOUTH	DODGE	DESOTO	CHRYSLER AND IMPERIAL	PER CAR	PART NUMBER
7-42-0 WATER PUMP								
7-42-1	WATER PUMP PACKAGE	6	59	59	-	-	1	1692 686
	MD2, w/o Air Conditioning	8	59	59	-	-	1	1752 422
	MP2 Fury, MD2-D500, MD2-D500 High Performance	8	59	59	-	-	1	1818 610
	MD3 w/o Air Conditioning	8	-	59	59	59 (1)	1	*1879 526
	w/Air Conditioning, MP2 High Performance, MD2-D500, MD3, MD3-D500, MS1, MC1	8	59	59	59	59 (2)	1	*2084 227
	w/Air Conditioning, MS2, MS3, MC2, MC3, MY1	8	-	-	59	59	1	1879 536
7-42-4	REPAIR KIT, Water Pump	6	59	59	-	-	1	1879 410
	MP2, MD2, High Performance, MD3	8	59	59	59	59	1	1843 447
	MD2	8	59	59	-	-	1	1752 435
	w/Air Conditioning, MP2 High Performance, MD2-D500, MD3, MD3-D500, MS1, MC1	8	59	59	59	59	1	2084 228
	w/Air Conditioning, MS2, MS3, MC2, MC3, MY1	8	-	-	59	59	1	1752 622
7-43-0 WATER PUMP HOUSING								
7-43-1	HOUSING	6	59	59	-	-	1	1674 700
	w/o Air Conditioning	8	59	59	59	59	1	1944 916
	w/Air Conditioning	8	59	59	59	59	1	1859 634
7-43-5	SCREW, Short, MD2	8	59	59	-	-	3	1672 556
	Medium, MD2	8	59	59	-	-	2	1672 557
	Long, MD2	8	59	59	-	-	1	1672 558
7-43-14	WASHER, Water Pump Body Screw Lock	6	59	59	-	-	4	1319 068
7-44-0 WATER PUMP GASKET								
7-44-3	GASKET, Body	6	59	59	-	-	1	1674 702
	MD2	8	59	59	-	-	1	1676 031
	MP2, MD2-D500, High Performance, MD2-D500, MD3	8	59	59	59	59	1	1737 705
7-44-4	GASKET, Pump to Cylinder Block	6	59	59	-	-	1	1735 036
	MP2, MD2	8	59	59	-	-	2	*1329 336
	MP2, MD2, High Performance, MD2-D500, MD3	8	59	59	59	59	2	*1737 761
	MP2, MD2-D500, High Performance, MD2-D500, MD3	8	59	59	59	59	2	1737 761
7-45-0 WATER PUMP SHAFT AND IMPELLER								
7-45-2	SHAFT, w/BEARING	6-8	59	59	59	59	1	1634 817
7-45-31	IMPELLER, 6 Blade	6	59	59	-	-	1	1852 594
	10 Blade, MD2	8	59	59	-	-	1	1635 783
	10 Blade, MP2, MD2-D500, High Performance, MD2-D500, MD3	8	59	59	59	59	1	1637 724
	w/Air Conditioning, 6 Blade, MP2 High Performance, MD2-D500, MD3, MD3-D500	8	59	59	59	59	1	1859 151
7-46-0 WATER PUMP SEAL								
7-46-1	SEAL PACKAGE	6-8	59	59	59	59	1	1243 631
7-46-10	WASHER, Seal Retainer	6-8	59	59	59	59	1	1674 679
7-48-0 WATER PUMP ELBOW OR NIPPLE								
7-48-22	NIPPLE, By-Pass, MD2	8	59	59	-	-	2	1618 668

NOTE 1: MC1, w/ or w/o Air Conditioning UP TO Serial No. 114930.

NOTE 2: MC1, w/Air Conditioning AFTER Serial No. 114930.

★ Indicates use as required.

☐ Indicates parts not listed in any previous parts book.
Feb. 15, 1960 Supersedes May 25, 1959.

Numerals in parentheses () refer to notes.

Printed in U.S.A.
Prices and specifications subject to change without notice.

* Indicates change or addition.