

# CHRYSLER CORPORATION

CHRYSLER SALES DIVISION  
12200 E. JEFFERSON AVE.  
DETROIT 31, MICHIGAN

## SERVICE BULLETIN



No. 1002-CH

March 1, 1957

TO ALL CHRYSLER DIRECT DEALERS:

The enclosed bulletin covers the data and specifications on the 1957 Chrysler 300-C.

The 300-C FirePower V-8 Engine, one of the finest, most efficient engines ever designed, develops 375 horsepower at 5200 rpm. It has two 4-barrel carburetors, a full race camshaft, mechanical valve lifters, adjustable valve rockers, heavy duty crankshaft, double valve spring, Trimetal main and rod bearings, and extra-deep exhaust seat valve inserts.

Combined with the FirePower engine is the revolutionary, new, fully-automatic Torque-Flite Transmission to make the finest and most efficient power train that, we believe, has been designed in the industry.

The Torque-Flite Transmission incorporates a high performance torque converter and planetary gears, a combination which gives incredible smoothness and exceptional performance throughout the entire speed range.

Another great engineering feature of the 300-C is the Torsion-Aire Ride--a revolutionary suspension system with torsion bar front springs, ball joint front wheel suspension, and a host of other suspension design features.

R. B. TEIPER  
Director of Service  
CHRYSLER DIVISION

MISCELLANEOUS

DATA

AND

SPECIFICATIONS

CHRYSLER

1957

C-300C

MODELS

IMPORTANT SERVICE INFORMATION • FILE IN YOUR SERVICE BULLETIN BINDER

PRINTED IN U.S.A.

## CONTENTS

Name	Page	Paragraph
Air Conditioning . . . . .	23	17
Body and Sheet Metal . . . . .	23	14
Brakes . . . . .	4	3
Clutch . . . . .	5	4
Cooling . . . . .	5	5
Electrical System . . . . .	6	6
Engine . . . . .	7	7
Frame, Springs and Shock Absorbers . . . . .	16	9
Front Wheel Suspension . . . . .	4	1
Fuel and Exhaust Systems . . . . .	11	8
Lubrication . . . . .	23	15
Radio, Hi-Fi and Heater . . . . .	23	16
Rear Axle . . . . .	4	2
Steering . . . . .	17	10
TorqueFlite Transmission . . . . .	17	11
Universal Joints and Propeller Shaft . . . . .	23	12
Wheels and Tires . . . . .	23	13

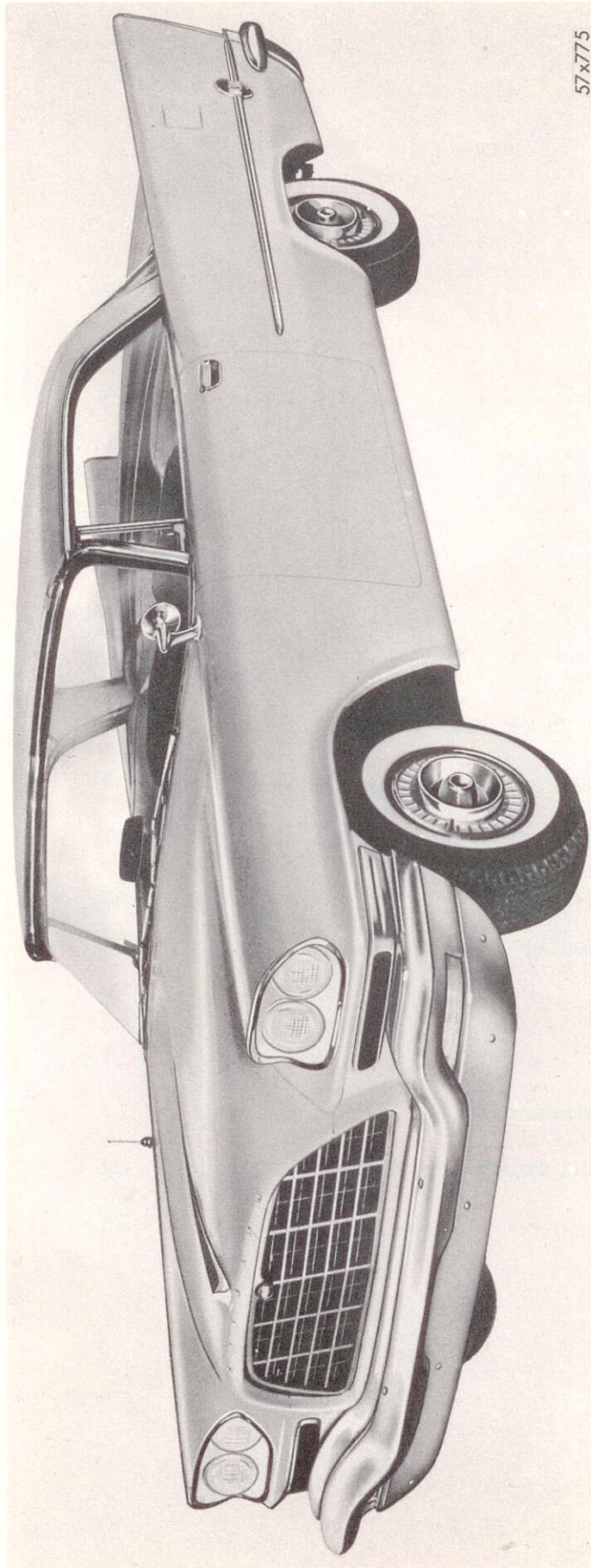

57x775

Fig. 1 - C-300C Sports-Coupe Two Door Hardtop

1957 CHRYSLER C-300C  
GENERAL DATA AND SPECIFICATIONS

Item	Body Style
Sports Coupe Two-Door HardTop and Convertible Coupe	
Wheel Base (Inches) . . . . .	126
Tread (Front) (Inches) . . . . .	61.2
Tread (Rear) (Inches) . . . . .	60.2
Length with Bumper. . . . .	219.2
Width with Bumper . . . . .	78.8
Rear Axle Ratio with TorqueFlite . . . . .	3.36
Tire Size . . . . .	9.00 x 14

1. FRONT WHEEL SUSPENSION

The Front Wheel Suspension is of the same basic design as used in Model C-76, in the Front Wheel Suspension, Section I of 1957 Chrysler Service Manual with the following exception:

The difference in the height between the floor and the two measuring points on each lower control arm should be within 1-3/4 to 1-7/8 inches. Service procedures will remain the same as outlined in Section I.

2. REAR AXLE

A standard or optional rear axle, of the same basic design as used on Model C-76, with the exception of the Optional Ratios as listed in Data and Specifications.

DATA AND SPECIFICATIONS - are the same as the C-76 with the following exceptions:

Optional Ratios Available

2.93 (41-14), 3.18 (35-11), 3.36 (37-11), 3.54 (39-11), 3.73 (41-11), 3.91 (43-11), 4.1 (41-10), 4.3 (43-10), 4.56 (41-9), 4.89 (44-9), 5.38 (43-8), 5.83 (35-6), 6.17 (37-6)

3. BRAKES

The Brakes are the same design as used on all 1957 models.

#### 4. CLUTCH

The Clutch is the same design as used on Model C-75, with exceptions listed as follows:

##### DATA AND SPECIFICATIONS

MODEL . . . . .	1447 (Borg-Beck)
TYPE . . . . .	Single Plate, Dry Disc
FACINGS . . . . .	Two
Material . . . . .	Molded Woven Asbestos
Inside Diameter (Inches) . . . . .	6.50
Outside Diameter (Inches) . . . . .	11.00
Thickness (Inches) . . . . .	0.125
Total Effective Area (Sq. Inches) . . . . .	123.15
Engagement Cushioning Method . . . . .	Springs, Flat, Crimped
Torsional Damping . . . . .	Coil Spring
Release Bearing . . . . .	Ball (Sealed)
PRESSURE SPRINGS (Number and Color) . . . . .	12 (9 white - 3 orange)
Individual Spring Pressure (Lbs.) . . . . .	white - 239 @ 1.515 inches orange - 167 @ 1.515 inches
Total Plate Pressure (Lbs.) . . . . .	2532
Total Spring Load (Lbs.) . . . . .	2652
DISC DAMPER SPRINGS (Number and color) . . . . .	6 red
SPACER NUMBER (As Used with Fixture C-585-A) . . . . .	21

To adjust or service the C-300C clutch, refer to the above Data and Specifications, and follow procedures as outlined in 1957 Chrysler Service Manual.

#### 5. COOLING SYSTEM

The Cooling System is the same design as used on Model C-76 except the SILENTFLITE Fan Drive is standard equipment. No shroud is used, except when equipped with air conditioning. The pulley ratio is 1.1 to 1. For servicing, refer to the Cooling System, Section V of the 1957 Chrysler Service Manual.

6. ELECTRICAL SYSTEM

The Battery, Starter, Electric Light Bulbs, Circuit Protectors, Regulator, Horns, Electric Windshield Wiper, Power Seat Lifts and Window Lifts are identical with those used on Model C-76, with exceptions listed in Data and Specifications.

DATA AND SPECIFICATIONS - ELECTRICAL  
GENERATOR

---

Car Model	C-300C
-----------	--------

---

Gen. Model	
Standard . . . . .	GHM-6010A; 1770748
With Air Conditioning . . . . .	GHM-6011A; 1779959
Rotation . . . . .	Clockwise at Drive End
Voltage . . . . .	12
Output . . . . .	Controlled by Vibrating Regulator
Rated Current Output . . . . .	30 Amperes
Bearings	
Standard . . . . .	Ball at drive end -- Bushings at opposite end
With Air Conditioning . . . . .	Ball -- Both ends
Ground Polarity . . . . .	Negative
Poles . . . . .	2
Brushes . . . . .	2
Spring Tension . . . . .	20 to 36 oz.
Field Coil Draw (Arm. to Field Term.) . . .	1.1 to 1.3 amps at 10 volts
Motorizing Draw . . . . .	2.3 to 2.6 amps at 10 volts
Test Bench Output Test (At 70° F) . . . . .	6 amps, 13.6 volts, at 950 Max. RPM 30 amps, 15 volts at 1800 Max. RPM

DISTRIBUTOR

The distributor is the same as C-76 and IM-1 except basic setting is 4° BTC instead of 6°.

SPARK PLUGS

Type . . . . .	Standard AGR 42 Hi-Speed AGR 32
Thread (mm.) . . . . .	14
Tightening Torque (lb. ft.) . . . . .	30 to 32
Gap . . . . .	.035"

7. ENGINE

The Chrysler C-300C Engine is a modified Chrysler FirePower engine. The modifications include two four-barrel carburetors, (Figs. 2 and 3), a new "lower"

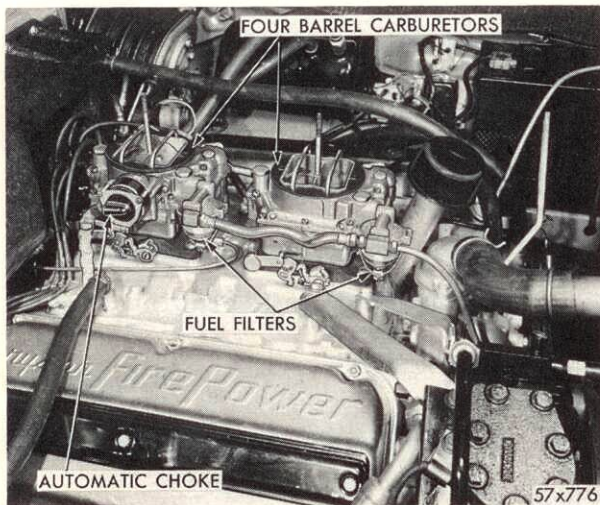

Fig. 2 - C-300C FirePower Engine (Right Side)

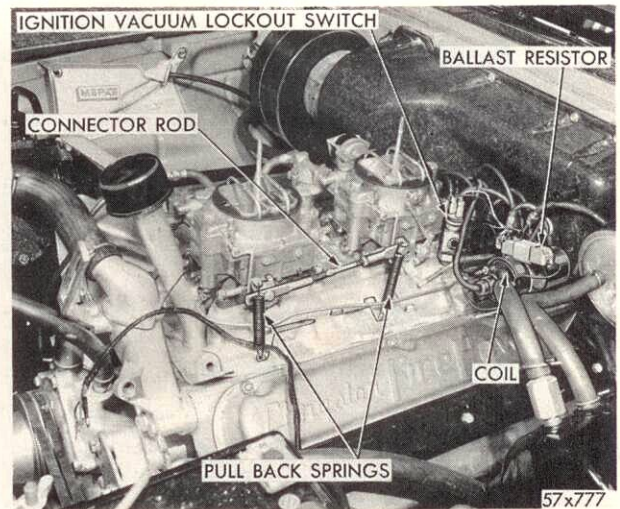

Fig. 3 - C-300C FirePower Engine (Left Side)

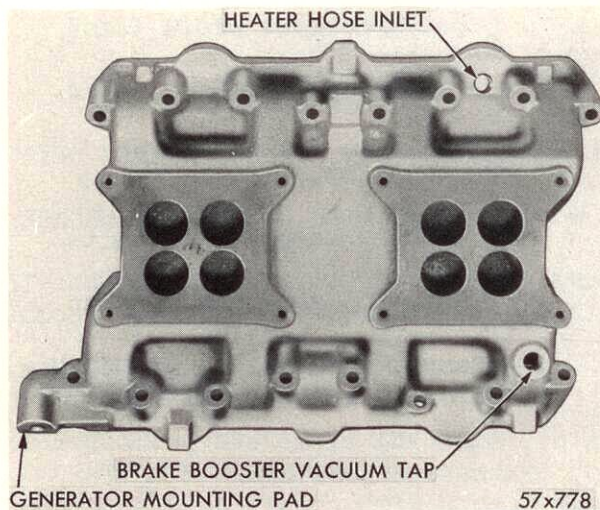

Fig. 4 - Intake Manifold, C-300C Engine

intake manifold, (Fig. 4), full race camshaft, special push rods and mechanical tappets with the adjusting screws at the push rod end of the rocker arms, inner and outer high load valve springs, removable exhaust valve seat inserts, special cylinder head covers, new air cleaners (Fig. 5), top compression chrome ring, hardened crankshaft and heavy duty main and rod bearings. The bearings should not be interchanged with the crankshaft bearings used in the standard FirePower engines.

The valve tappet clearance is adjusted at the rocker arm as shown in Figure 6 to the following values:

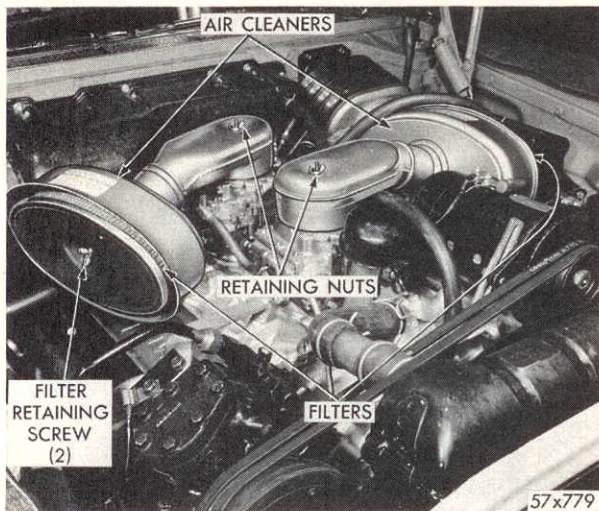

Fig. 5 - Carburetor Air Cleaners Installed

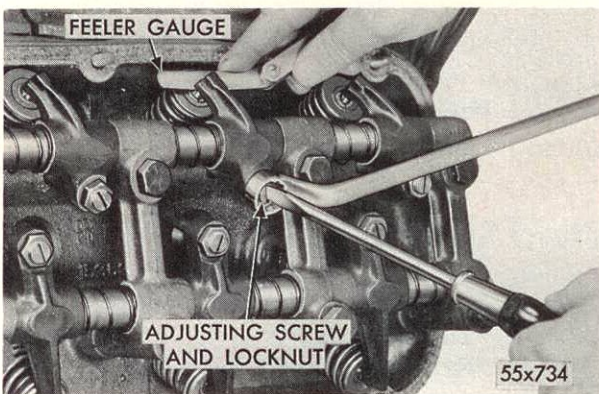

Fig. 6 - Adjusting Valve Cleaner

	<u>HOT</u>	<u>COLD</u>
--	------------	-------------

Intake	.015"	.015"
Exhaust	.024"	.028"

Engine Idle Setting - Set Idle adjustment to obtain a smooth idle at 650 rpm, as outlined in Fuel Section.

Ignition Timing - Disconnect distributor vacuum line, set ignition at 4 degrees BTDC, and reset engine idle back to 650 rpm.

Valve Timing Checking - Turn the crankshaft until Number One intake valve is closed and Number One piston is on Top Dead center (TDC).

Install a dial indicator so that the pointer contacts the valve spring retainer as nearly at a right angle as possible. Since the C-300C has mechanical tappets, it is not necessary to allow time for the tappet to bleed down.

Adjust the valve rocker screw to afford zero clearance. Then set the dial indicator to zero and turn the crankshaft clockwise (normal running direction) until the dial indicator shows that the valve has lifted .081 inch.

The timing marks on the vibration damper should read from 5 degrees BTC to 7 degrees ATC. If the reading is not within the specified limits, check the gear index marks and inspect the timing chain for wear.

Before making this check, determine the accuracy of the TDC mark on the damper by bringing the number one piston to TDC with an indicator placed in the spark plug hole. After the valve timing has been checked, reset the valve lash to the specified operating limits.

Service Procedure will be the same as outlined for the FirePower Engine, in the Engine Section VII of the 1957 Chrysler Service Manual, with the following exceptions:

Engine Specifications are the same as the C-76 and IM-1 with the following exceptions:



DATA AND SPECIFICATIONS - ENGINE

CRANKSHAFT

Type . . . . . Fully Counter-Balanced, Hardened  
Bearings . . . . . Tri-Metal  
Diameter Clearance (Desired) . . . . . .001 to .0025"  
(Tri-Metal)

BEARING SIZES

Diameter and Length . . . . . 2.688 x .905  
2.688 x .905  
2.688 x .997  
2.688 x .905  
2.688 x 1.625

TAPPETS

Type . . . . . Mechanical  
Clearance in Block . . . . . .0005 to .0015"  
Body Diameter . . . . . .9040 to .9045"  
Clearance Between Valve Stem and  
Rocker Arm . . . . . \*Intake .015"  
\*Exhaust .024"

\*Engine Hot and Idling

VALVES -- (Intake)

Adjustment . . . . . At Rocker Arm  
Lift . . . . . .444"

VALVES -- Exhaust

Adjustment . . . . . At Rocker Arm  
Lift . . . . . .435"

VALVE SPRINGS - Outer

Number . . . . . 16  
Free Length . . . . . 1-7/8"  
Load When Compressed to (valve closed) . . . 1-21/32" -- 58 to 63 lbs.

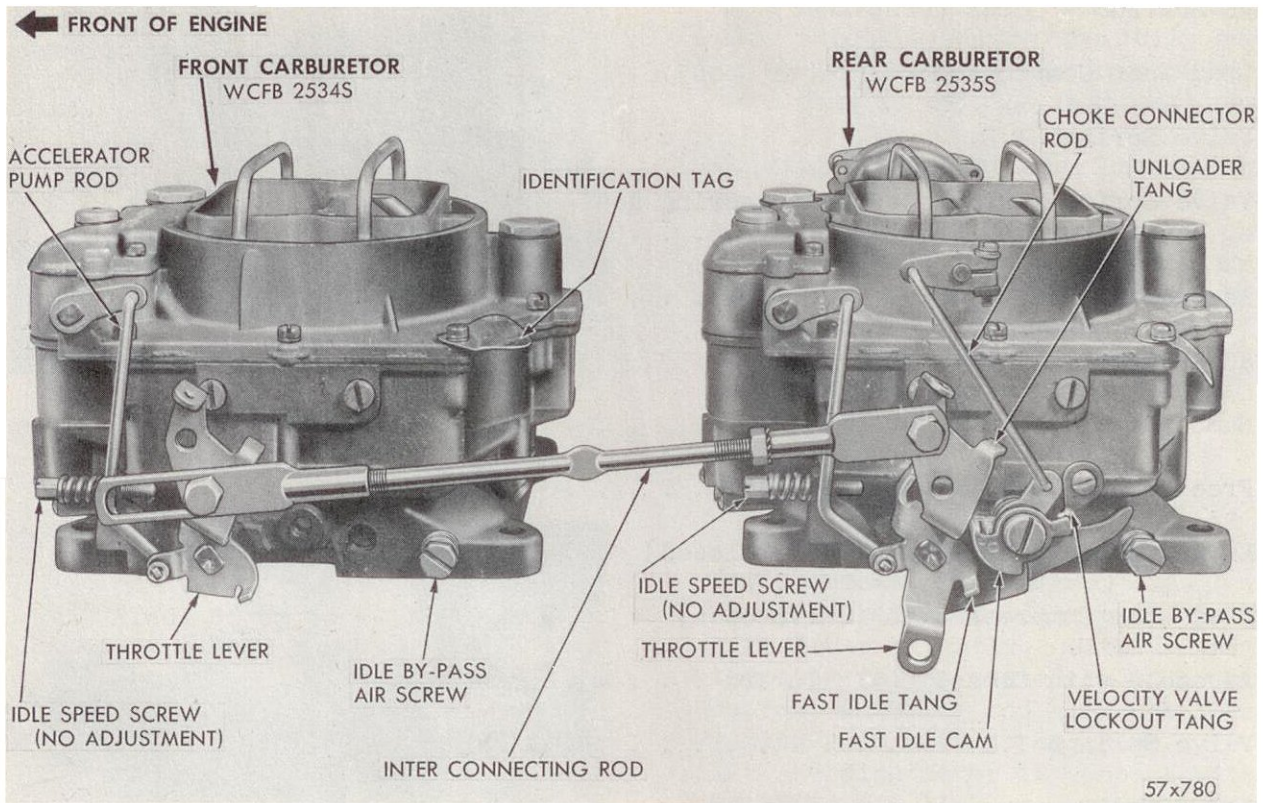

Fig. 7 - Dual Carburetors (Left Side View)

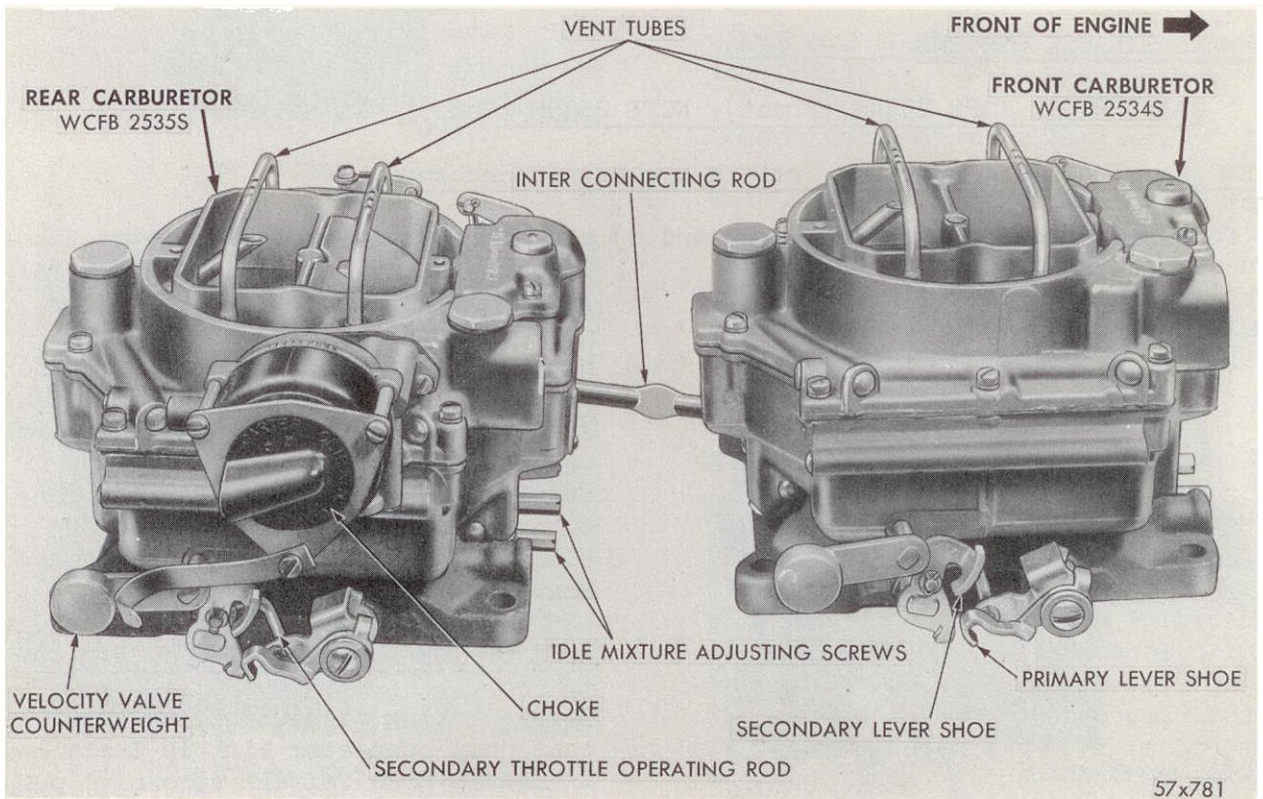

Fig. 8 - Dual Carburetors (Right Side View)

VALVE SPRINGS - Outer (Continued)

Load When Compressed to (valve open). . . . 1-7/32" -- 156 to 161 lbs.  
 Valve Springs I.D. . . . . . .990 to 1.010"  
 Valve Spring Installed Height (spring seat  
 to retainer). . . . . . 1-5/8 to 1-11/16"  
 Recondition at . . . . . 1-23/32"

VALVE SPRINGS - Inner

Number . . . . . 16  
 Free Length . . . . . 1-25/32"  
 Load When Compressed to (valve closed) . . 1-17/32" -- 26 to 30 lbs.  
 Load When Compressed to (valve open) . . . 1-30/32" -- 64 to 69 lbs.  
 Assemble with Closed Coils Toward . . . . . Head  
 Valve Springs I.D. . . . . . .690 to .710"

CYLINDER HEAD

Valve Seat Insert Material . . . . . Alloy Iron

8. FUEL AND EXHAUST SYSTEMS

CARBURETORS WCFB 2534S (Front), WCFB 2535S (Rear)

NOTE: The front and rear carburetors are not interchangeable.

The four-barrel carburetors (Figs. 7 and 8) are of the same basic design as those used in the C-76 Models with the following exceptions: The carburetor metering and throttle levers have been redesigned. The rear carburetor only is equipped with a choke system. The carburetors have velocity control valves on secondary barrels. For Service Procedure refer to WCFB carburetor, Fuel and Exhaust Section VIII of the 1957 Chrysler Service Manual.

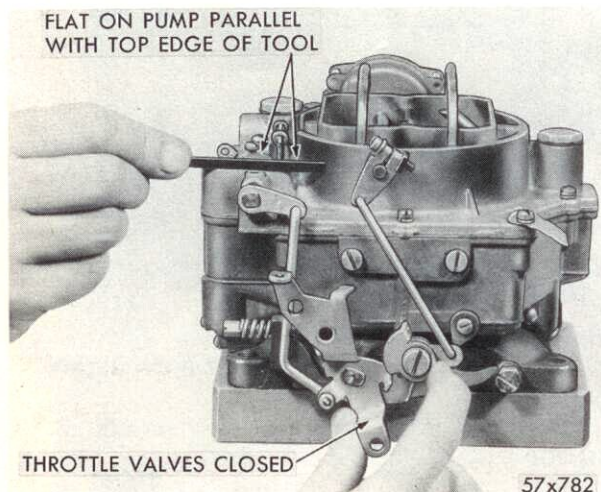

Fig. 9 - Accelerator Pump Adjustment

ACCELERATOR PUMP ADJUSTMENT (Fig. 9)

Before making adjustment, be sure that pump connector link is installed in middle hole (middle stroke of pump lever), with ends extending toward accelerator pump shaft arm. Back off

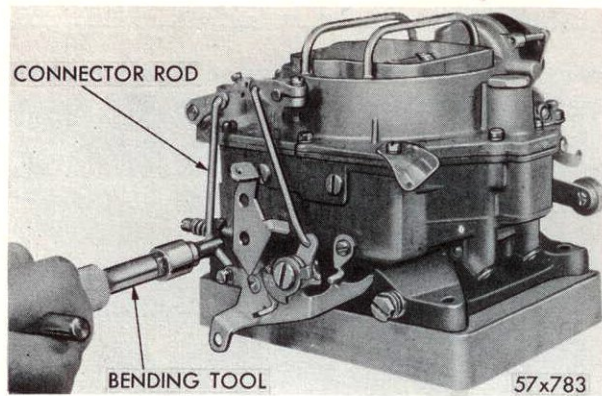

Fig. 10 - Bending Throttle Connector Rod

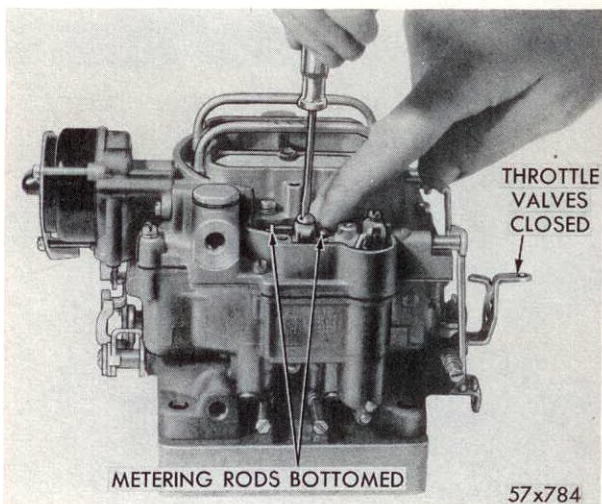

Fig. 11 - Metering Rod Adjustment

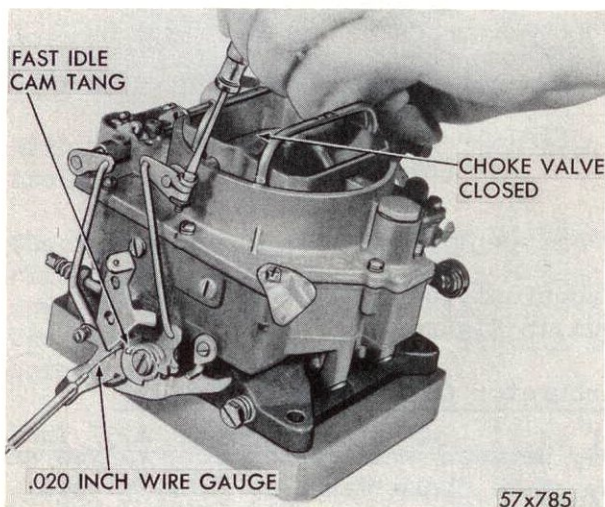

Fig. 12 - Choke Rod Adjustment (Rear Carburetor)

idle speed adjusting screw until primary throttle valves are fully seated in their bores. (Make sure that fast idle tang is off the fast idle cam.)

Holding a straight edge across top of dust cover boss, as shown in Figure 9, adjust length of pump rod until the flat on top of pump arm (under set screw) is parallel with upper edge of straight edge. To adjust pump setting, bend throttle connector rod at the lower angle, using Tool T-109-213, as shown in Figure 10.

#### METERING ROD ADJUSTMENT

Loosen set screw in metering rod arm (if previously tightened) enough to obtain a slight bind on pump shaft. Lift lever slightly. With primary throttle valves seated in their bores, depress metering rod link until metering rods bottom, as shown in Figure 11. Keeping lever in contact with the metering rod link, tighten set screw securely.

#### CHOKE ROD ADJUSTMENT (Rear Carburetor Only)

Loosen choke lever clamp screw. Insert a .020 inch wire gauge, Tool T-109-200, between tang on fast idle cam and boss on throttle body casting. Hold gauge in place by pressure of screwdriver exerted on choke lever clamp screw, as shown in Figure 12. This will automatically take up all slack in the linkage. Hold choke valve tightly closed, and tighten clamp screw.

#### CHOKE UNLOADER ADJUSTMENT (Rear Carburetor Only)

With the primary throttle valves held in wide open position, insert 3/16 inch gauge, Tool T-109-28 between upper edge of choke valve and inner dividing wall of air horn, as shown in Figure 13. With finger pressing against upper part of choke valve,

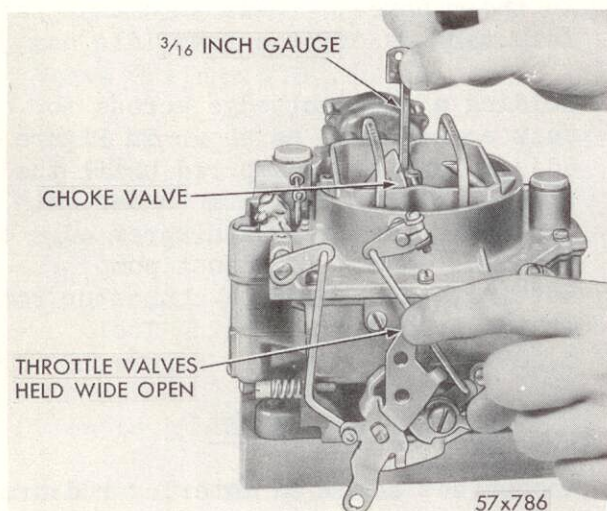

Fig. 13 - Choke Unloader Adjustment  
(Rear Carburetor)

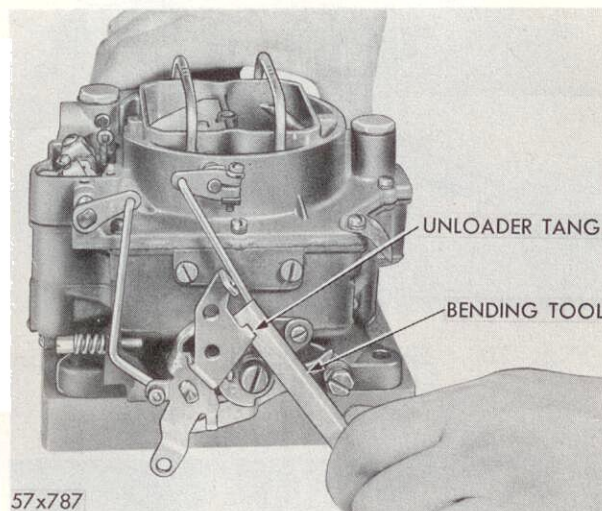

Fig. 14 - Bending Unloader Tang  
(Rear Carburetor)

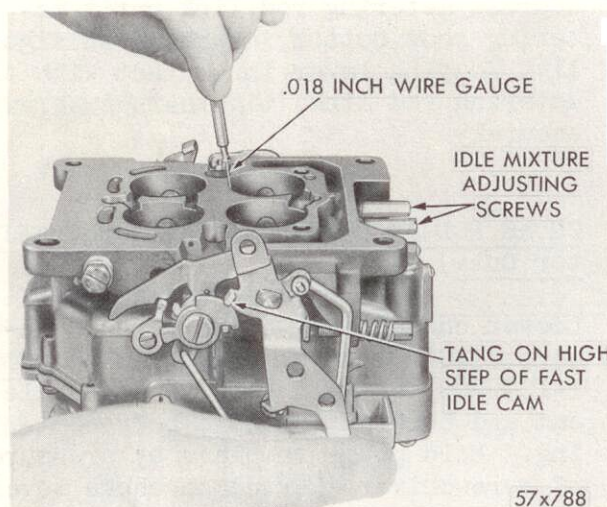

Fig. 15 - Checking Fast Idle  
Adjustment (Rear Carburetor)

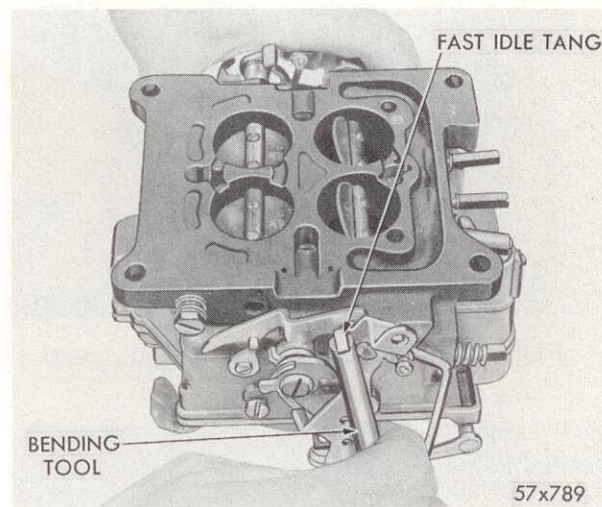

Fig. 16 - Fast Idle Adjustment  
(Rear Carburetor)

slight drag should be felt on gauge as it is being withdrawn.

If no drag is felt, or if too much drag is apparent, bend unloader tang on throttle lever, using Tool T-109-41, as shown in Figure 14.

FAST IDLE ADJUSTMENT -- (ON BENCH) (Rear Carburetor Only) (Figs. 15 & 16)

Insert a .018 inch wire gauge, Tool T-109-44, between primary throttle valves and side of bore opposite idle adjusting screws. Move choke valve to fully closed position, and bend fast idle tang using Tool T-109-214 (Fig. 16) to give a slight drag on gauge when tang is resting on high step of fast idle cam, as shown in Figure 15.

## SECONDARY THROTTLE LEVER ADJUSTMENT

Primary and secondary throttle valves should reach wide open position at the same time. To adjust, bend throttle operating rod at upper angle (Fig. 8) using Tool T-109-213. With primary and secondary valves in tightly closed position, there should be .020 inch clearance between positive closing shoes on primary and secondary throttle levers. To adjust, bend shoe on primary lever (Fig. 8) using Tool T-209-29.

## VELOCITY VALVE LOCKOUT ADJUSTMENT (Rear Carburetor Only)

Make this adjustment after completing fast idle adjustment and secondary throttle lever adjustments. Slightly open throttle valves and manually open and close the choke valves. When finger pressure is exerted on velocity valve counterweight (Fig. 17), tang on velocity throttle lever should fully engage in notch of lock out dog. If necessary to adjust, bend tang on velocity throttle lever.

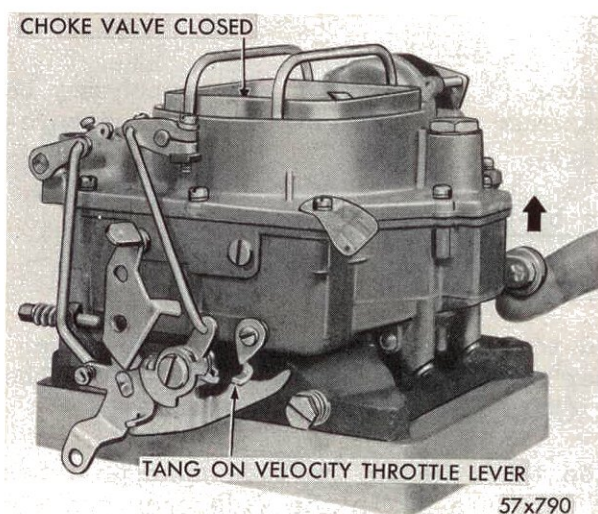

Fig. 17 - Checking Velocity Valve Lockout Adjustment (Rear Carburetor)

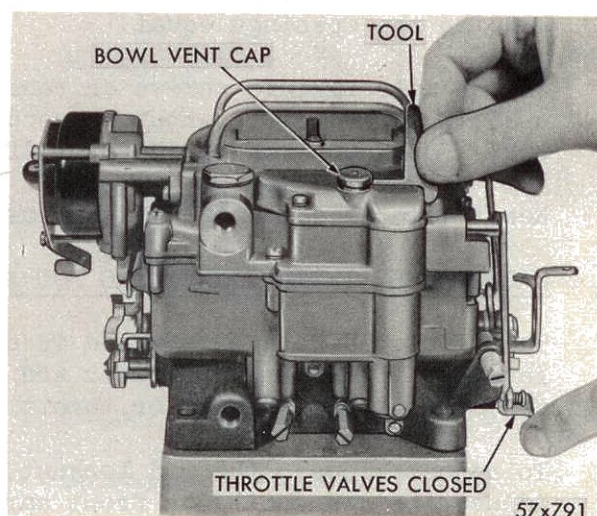

Fig. 18 - Checking Bowl Vent Cap Adjustment Using Tool T-109-197

## BOWL VENT CAP ADJUSTMENT

With throttle valves closed, the bowl vent cap should lift approximately 1/16 inch off its seat.

Check the clearance using Tool T-109-197, as shown in Figure 18. To increase clearance, remove dust cover and bend actuating arm. To decrease clearance press down on cap until correct clearance has been obtained. After adjustments have been checked and corrected, install metering rod dust cover and gasket. Install screws and tighten securely.

## FAST IDLE ADJUSTMENT (On Car) (Fig. 7)

Before setting fast idle, engine should be fully warmed and running at 600 to 650 rpm. Remove air cleaners. Remove hairpin clip from choke connector rod. Stop engine and open throttles halfway. Close choke blade fully, while holding throttles open.

Let throttle close, making certain fast idle adjusting tang contacts highest step of fast idle cam. Remove lower end of choke connector rod from fast idle cam and allow choke blade to open fully.

Start engine without touching throttle and check engine rpm. Adjust fast idle adjusting tang (Fig. 16) until the desired 1450 to 1500 rpm has been obtained as follows:

Open throttles until fast idle adjusting tang can be reached easily with Tool T-109-41. Bend tang and repeat above steps until desired fast idle speed is obtained. Install choke connector rod, hairpin clip and air cleaners.

#### IDLE SPEED AND MIXTURE ADJUSTMENT (Carburetors on Engine)

Warm engine up to normal temperature. Connect tachometer. Set idle mixture screws 1 turn open (Fig. 8). Set idle by-pass air screws 1 turn open (Fig. 7), adjust idle speed to approximately 600 rpm by opening or closing by-pass screw, keeping the openings equal.

Adjust idle mixture screws on rear carburetor (a  $\frac{1}{4}$  inch open end wrench may be used if screwdriver cannot be used) for maximum rpm. Repeat on front carburetor. Re-adjust rear carburetor if necessary.

Reset idle speed to 600-650 rpm using idle by-pass air screws.

#### CARBURETORS INTER CONNECTING ROD ADJUSTMENT

The elongated hole of the rod is connected to the lower hole in the throttle lever of the front carburetor and the other end of the rod is connected to the top of the rear carburetor throttle lever (Fig. 7).

To adjust, loosen the rod locknut, hold the throttle in the wide open position. Adjust the rod until the front carburetor throttle is in the wide open position. Tighten locknut.

#### DATA AND SPECIFICATIONS

##### CARBURETOR

Make . . . . . Carter  
Type . . . . . 4 Barrel Downdraft  
Model  
Front carburetor . . . . . WCFB 2534S  
Rear carburetor . . . . . WCFB 2535S  
Nominal Size . . . . .  $1\frac{1}{4}$  inch 4 Bore 4 Bolt

#### ADJUSTMENTS

Float Setting (gasket to top of floats)

Primary . . . . .  $1/8$  inch

DATA AND SPECIFICATIONS (Continued)

ADJUSTMENTS (Continued)

Secondary . . . . .	3/16 inch
Choke Rod . . . . .	.020 inch
Choke Unloader . . . . .	3/16 inch
Fast Idle . . . . .	.018 inch
Idle Speed . . . . .	650 rpm
Idle Mixture (both screws, both carburetors) . . . . .	Approximately 1 full turn open - Set for best idle
Accelerator Pump . . . . .	Middle Stroke

CHOKE

Control . . . . .	Integral Automatic
Choke Setting . . . . .	1 Notch Rich

SPECIAL TOOLS

T-109-28 . . . . .	Gauge, Choke Unloader (3/16")
T-109-29 . . . . .	Gauge, Wire (.020")
T-109-41 . . . . .	Bending Tool, Tang
T-109-44 . . . . .	Gauge, Wire .018
T-109-197 . . . . .	Bowl Vent Cap Gauge 1/16"
T-109-200 . . . . .	Gauge, Wire (Fast Idle)
T-109-213 . . . . .	Bending Tool, Rod
T-109-214 . . . . .	Bending Tool
T-109-222 . . . . .	Gauge, Float Level (Secondary) 3/16"
T-109-232 . . . . .	Gauge, Float Level (Primary) 1/8"
C-3400 . . . . .	Stand, Carburetor Repair

9. FRAME, SPRINGS AND SHOCK ABSORBERS

The frame is of the same basic construction as used in the C-76 Models, with straightening and aligning procedures the same. The rear springs differ only



in the rate of deflection. The shock absorbers are of the heavy duty type. For servicing of the Frames, Rear Springs and Shock Absorber assemblies, refer to Section IX of the 1957 Chrysler Service Manual.

#### 10. STEERING

The manual and power steering gear assemblies are of standard design except that a longer steering shaft and jacket assembly is used on models equipped with 3-speed standard transmission. The steering assemblies are serviced as indicated in Section X of the 1957 Chrysler Service Manual.

#### 11. TORQUEFLITE TRANSMISSION

Servicing procedures for the TorqueFlite transmission remain essentially the same as outlined in the 1957 Chrysler Service Manual, with the following exceptions:

##### Normal Driving

For fully automatic driving, the D (Drive) button is engaged. The car will automatically upshift into Second, and then into Direct at speeds determined by the driver. With light to moderate acceleration, the first shift will be from 15 to 30 MPH. Similarly, the final shift will be from 20 to 60 MPH. By pressing the accelerator "through" detent, the upshift speeds are greatly delayed for obtaining maximum performance. This carries the first shift to 45 MPH, and the final shift to 75 MPH. When slowing down, the transmission shifts directly into Low, bypassing Second. This shift is free from the usual bumps and noises, since Low ratio makes use of the overrunning clutch.

##### Rapid Acceleration

When cruising below 65 MPH, a kickdown into Second (by fully depressing the accelerator) provides added acceleration. If car speed is below 30 MPH, the transmission will downshift into Breakaway.

##### 1 (Low) Position

The 1 (Low) position is provided for severe driving conditions giving maximum power for climbing steep upgrades and engine braking for downgrades. The 1 (Low) button may be pushed at any speed. A downshift to Second will occur at speeds below 65 MPH, and to Low ratio below 30 MPH.

##### 2 (Second) Position

This selection provides operation similar to D position, except that the transmission will remain in Second at speeds below 75 MPH, regardless of accelerator opening.

R (Reverse) may be obtained by pushing the R (Reverse) button when the car is stopped or moving less than 5 MPH. A safety interlock prevents use of R (Reverse) above 15 MPH.

##### Parking

The fully independent handbrake is engineered for safety. It should be used under all normal parking conditions.

## Towing

The car may be towed for short distances and at moderate speeds with the transmission in N (Neutral). For longer distances, or IF THE TRANSMISSION IS INOPERATIVE, DISCONNECT THE DRIVE SHAFT OR TOW WITH THE REAR WHEELS OFF THE GROUND.

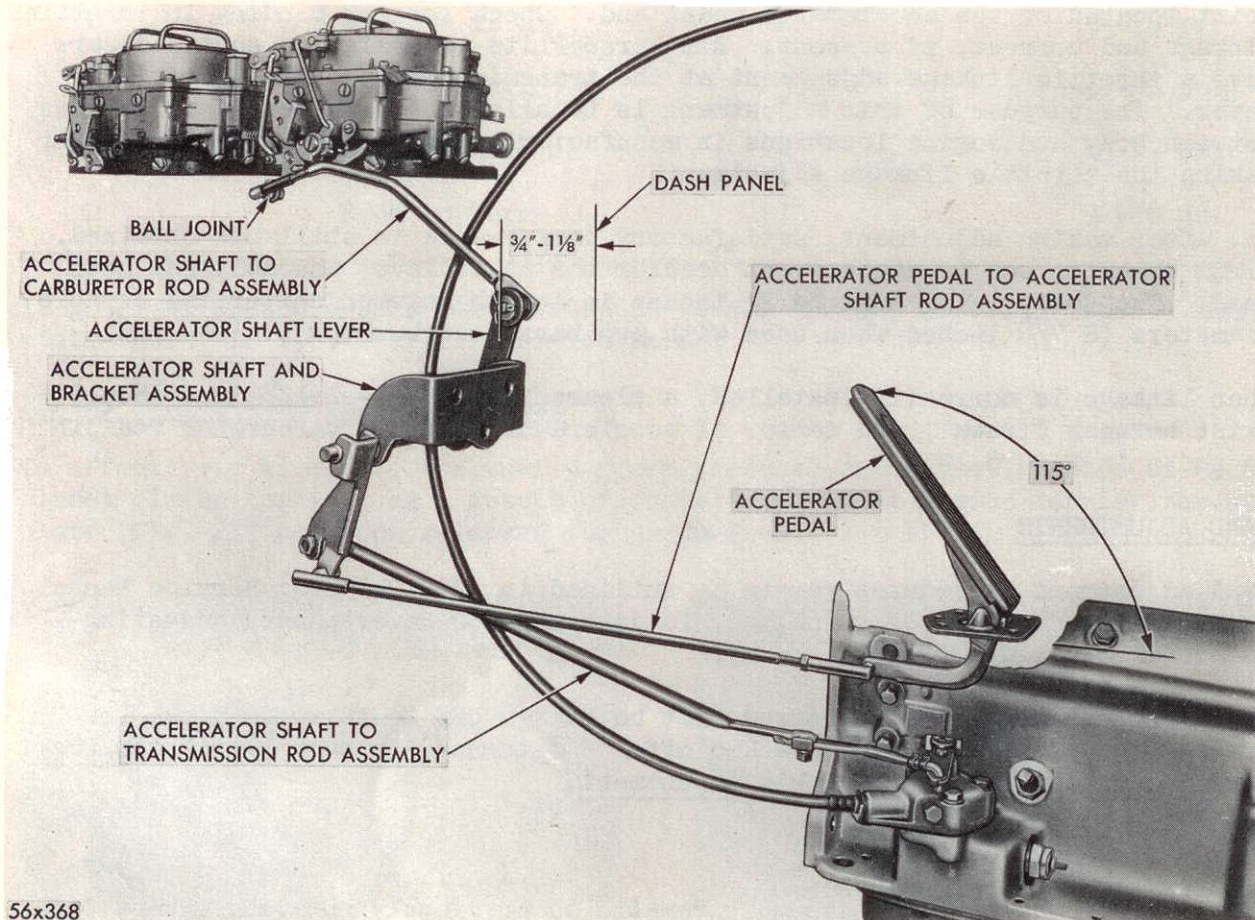

Fig. 19 - Transmission Throttle Linkage

### TRANSMISSION THROTTLE LINKAGE ADJUSTMENT (Refer to Figure 19)

Run engine until normal operating temperature is reached. Remove rear carburetor air cleaner and check that the choke is in a fully opened position. Connect tachometer to coil and ground then proceed to adjust and set engine idle as described under "Idle Speed and Mixture Adjustment" and set carburetors inter connecting rod as described under "Carburetors Inter Connecting Rod Adjustment", of this bulletin. After completing engine idle and inter connecting rod adjustments, proceed as follows:

Unsnap accelerator shaft to carburetor rod assembly from ball joint on rear carburetor throttle lever. Move the rod rearward until rod is stopped by the idle stop on the transmission idle cam. With rod lightly preloaded against transmission idle cam stop, ball joint (on rear carburetor throttle lever) should be in alignment with ball joint clip on accelerator shaft to carburetor rod. If not in alignment, lengthen or shorten rod adjustable end (threaded) until alignment is obtained, then engage ball joint with rod end clip.

Start engine and recheck idle setting (600-650 RPM) with N (Neutral) push button engaged and handbrake applied. Check the accelerator pedal angle to make sure it is 115 degrees to the horizontal (Fig. 19). Proper pedal angle is obtained by adjusting the accelerator pedal to accelerator shaft rod length at the ball joint located on the accelerator pedal end. Check for any binding in throttle linkage and correct, if present. All TorqueFlite transmission equipped cars have a throttle linkage adjustment at the transmission throttle operating lever. The purpose of this adjustment is to allow for permissible variations between body and engine locations in manufacturing and should not be used for making the throttle linkage adjustment.

If, after making adjustment, satisfactory performance is still not obtained, first check to see if the correct accelerator shaft lever assembly has been used. The shaft lever must be  $3\frac{1}{4}$  inches in length between centerline of hole diameters ( $2\frac{7}{8}$  inches when used with two barrel carburetor).

When linkage is correctly installed, a clearance of  $\frac{3}{4}$  -  $1\frac{1}{8}$  inch should exist between firewall and center of accelerator shaft to carburetor rod pin as shown in Figure 19.

#### BAND ADJUSTMENTS

Band adjustment procedures remain as outlined in 1957 Chrysler Service Manual except for the number of turns the kickdown and Low-Reverse band adjusting screws are backed off.

The kickdown band adjusting screw must be backed off  $2\frac{1}{4}$  turns, and the Low-Reverse band adjusting screw backed off  $2\frac{5}{8}$  turns. Be sure to tighten lock screw securely after making this adjustment.

#### GOVERNOR ASSEMBLY

Servicing of the governor assembly remains as previously outlined except for this precaution: Should it ever become necessary to replace either the governor outer weight and/or outer weight spring (Fig. 20), it is essential that the following parts be used:

<u>Part Name</u>	<u>Part Number</u>
Outer weight	1823726
Spring	1823709

Be sure to re-check governor pressure.  
See Chart - next paragraph.

#### PRESSURE CHECKS

Pressure check procedures remain unchanged, except for governor values, which are given in the following chart:

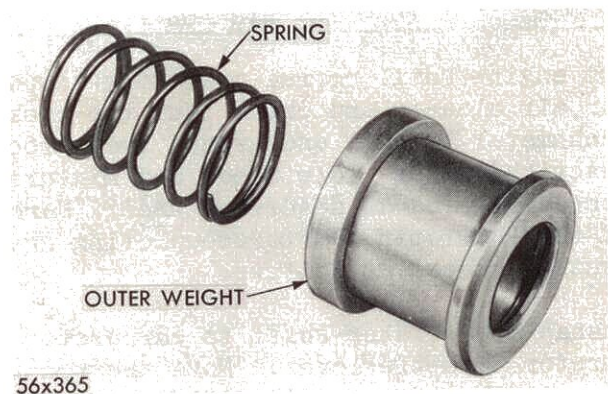

Fig. 20 - Governor Outer Weight and Spring

## GOVERNOR PRESSURE CHART

Push Button Position	Rear Wheels	Car Speed (M.P.H.)	Governor Pressure (P.S.I.)
D	Free to Turn	21	14-16 psi
D	Free to Turn	30	27-33 psi
D	Free to Turn	43	43-47 psi
D	Free to Turn	73	72-78 psi

If governor pressure does not correspond to car speeds, consult "Trouble Diagnosis Chart" in 1957 Chrysler Service Manual.

### PLANET PINION CARRIER THRUST PLATE

To effectively eliminate the wear pattern produced on the mating face of each planet pinion carrier, as a result of contact, a planet pinion carrier thrust plate (Fig. 21) has been released for production.

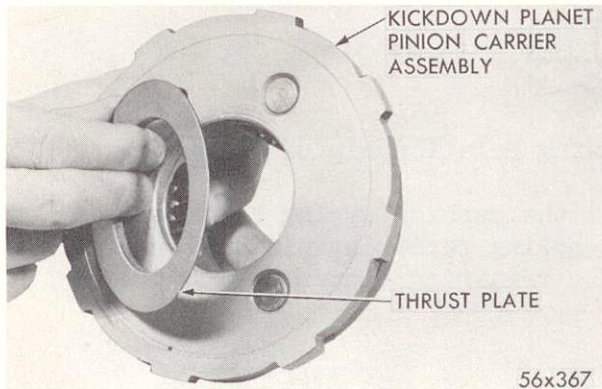

Fig. 21 - Installing Planet Pinion Carriers Thrust Plate

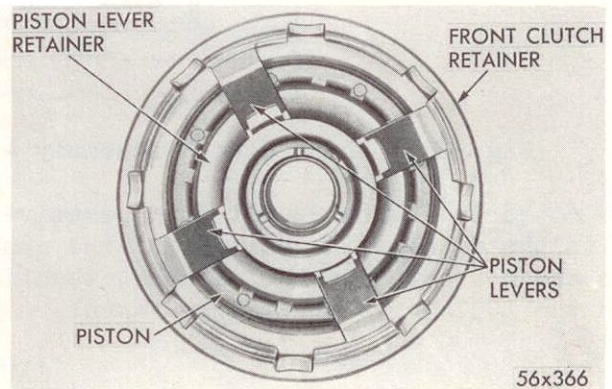

Fig. 22 - Front Clutch Piston Lever Installed in Retainer

The thrust plate (Part #1638667) pilots on the kickdown planet pinion carrier face to provide a spacer requirement of .015 inch between carriers. During reconditioning of the transmission assembly, it is recommended that the thrust plate be installed -- if it is noted that the thrust plate was not previously installed.

### ASSEMBLING THE FRONT CLUTCH

(Special Note To Information Outlined in 1957 Chrysler Service Manual)

When assembling the front clutch assembly particular attention must be paid to the correct sequence and positioning of the individual elements into the retainer.

The four piston levers must be installed within the retainer as shown in

Figure 23. After installing pressure plate, discs and plates in proper sequence (Figure 22), install cushion spring retaining plate. When correctly installed, the cushion spring retaining plate will rest on the shoulder in the bore of the retainer. (Refer to inset of Figure 23).

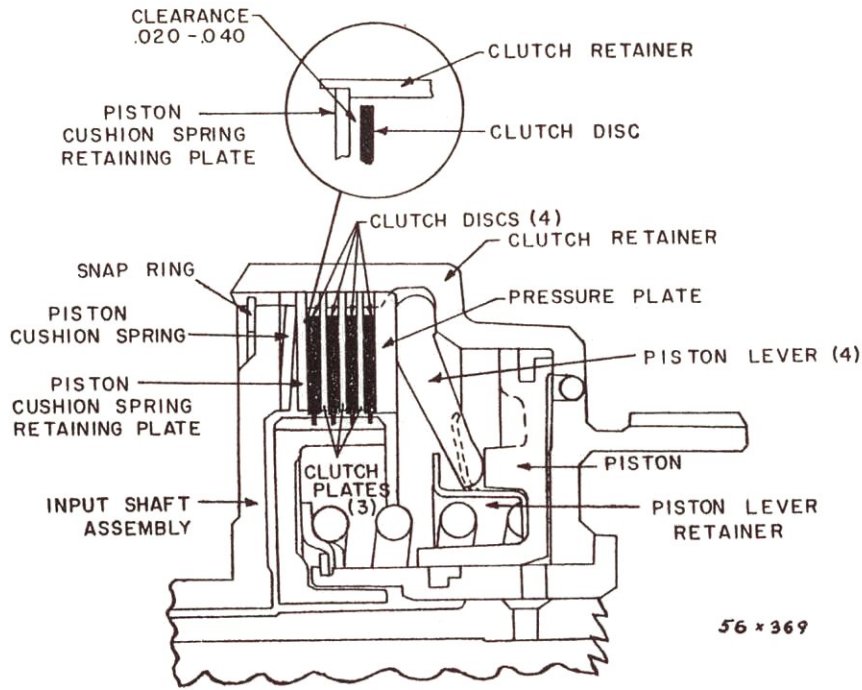

Fig. 23 - Front Clutch Assembly - Showing Relationship of Parts

As noted in Figure 23, it is imperative that the cushion spring be installed with the dished side contacting the cushion spring retaining plate. Proceed to check front clutch clearance, then install remaining elements as outlined in the 1957 Chrysler Service Manual.

CAUTION

Do not stall test the torque converter. For safety reasons and because damage to the transmission may result, wide open throttle stall operation is not recommended.

Data and Specifications follow:

DATA AND SPECIFICATIONS

Type . . . . .	Torque Converter with Gears
Torque Converter Diameter (inches) . . . . .	12 $\frac{1}{2}$
Oil Capacity of Transmission and Torque Converter . . . . .	12 qts. (Automatic Transmission Fluid Type "A")
Method of Cooling . . . . .	(Heat Exchanger Integral with Radiator)

DATA AND SPECIFICATIONS (Continued)

Lubrication . . . . .	Pumps (Rotor Type)
Number of Rear Clutch Plates - Discs (each)	5
Number of Front Clutch Plates . . . . .	3
Front Clutch Backing Plate . . . . .	1
Number of Front Clutch Discs . . . . .	4
Torque Converter Maximum Ratio at stall at Engine Speed . . . . .	2.3 at 1950 RPM

GEAR RATIOS

1 - Low . . . . .	2.45 to 1
2 - Second . . . . .	1.45 to 1
D - Drive . . . . .	1.00 to 1
R - Reverse . . . . .	2.20 to 1
N - Neutral . . . . .	--

FRONT - REAR PUMPS

Type . . . . .	Gear (Rotary)
End Clearance (Front Pump) . . . . .	.001 to .0025 inch
End Clearance (Rear Pump) . . . . .	.001 to .0025 inch

THRUST WASHERS

Input Shaft . . . . .	.115 to .117 inch .097 to .099 inch .078 to .080 inch
Front Clutch and Sun Gear . . . . .	.062 to .064 inch
Output Shaft . . . . .	.062 to .064 inch

SNAP RINGS

Kickdown Annulus Gear . . . . .	.060 to .062 inch .064 to .066 inch
Rear Clutch . . . . .	.060 to .062 inch
Low - Reverse Planet Pinion Carrier . .	.060 to .062 inch .064 to .066 inch .068 to .070 inch



to accommodate the air cleaner installation. Removal, installation, and servicing of the air conditioning units are the same as indicated in the 1957 Chrysler Service Manual

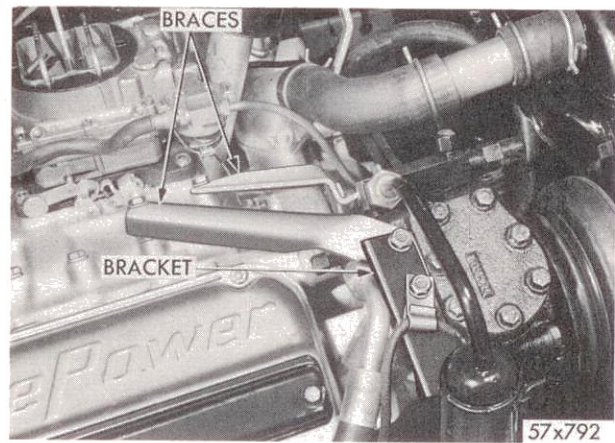

Fig. 24 - Compressor Braces and Bracket Installed

NOTES

---

---

---

---

---

---

---

---

---

---

---

---

---

---

---

---

---

---

---

---

---

---

---

---

---

---

---