

Section IX

FRAMES, SPRINGS AND SHOCK ABSORBERS

CONTENTS

	Page
Checking Frame Dimensions	199
Frame Alignment	200
Spring Maintenance	201
Rear Spring Interliners.....	202
Shock Absorbers	203
Servicing the Oriflow Shock Absorbers.....	204

DATA AND SPECIFICATIONS

FRAME			
Models	C-75	C-76	IM-1, 2 & 4
TYPE	Welded, Double-Channel Box Section, Side-Rails		
DIMENSIONS	See Figures 1, 2, and 3		

REAR SPRINGS			
TYPE		Semi-Elliptic	
NO. OF LEAVES			
SEDANS	5½	6½	6½
TOWN & COUNTRY WAGON	6½	6½	—
WIDTH	2.5	2.5	2.5
LENGTH	58"	58"	58"
SHACKLE	Silent Block Rubber Bushings		
HANGER	Side Strapped with Rubber Bushed Bolts		

SHOCK ABSORBERS

Models	C-75	C-76	IM-1, 2 & 4
TYPE	Oriflow, Double Acting, Hydraulic		
TORQUE SPECIFICATIONS			Foot-Pounds
REAR SPRING SILENT BLOCK NUT			100
SHOCK ABSORBER STUD NUT		$\frac{1}{2}$ " UPPER.....	60
		$\frac{9}{16}$ " LOWER.....	70
REAR SPRING U-CLIP BOLT NUTS			70
REAR SPRING SHACKLE NUTS $\frac{7}{16}$ "			50
SHOCK ABSORBER MOUNT NUT (REAR)			60

ESSENTIAL TOOLS

C-3413 Remover and Installer—Shock Absorber Lower Mounting Assembly

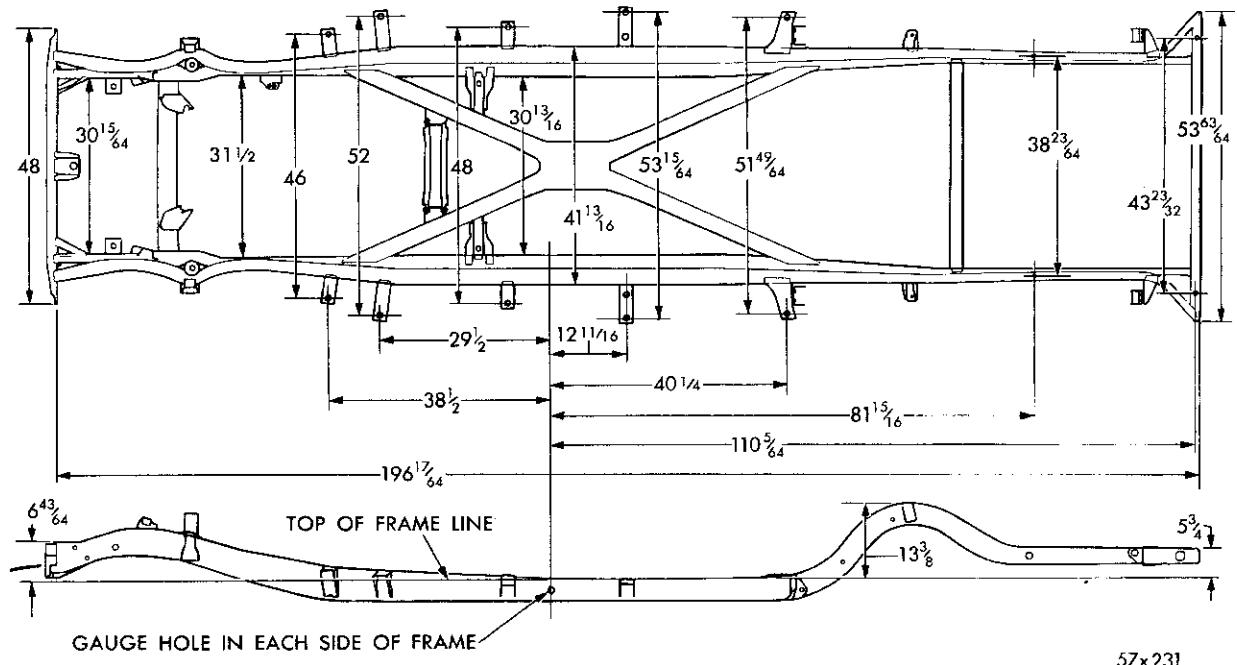

57x231

Fig. 1—Frame Dimensions, Windsor and New Yorker

SECTION IX

FRAMES, SPRINGS AND SHOCK ABSORBERS

FRAME

A new full length box section frame with re-designed crossmembers and longer side rails are used on 1957 Chrysler Models.

Two front crossmembers are now used, the forward member for bumper, radiator support and strut attachment and the other for engine and suspension support.

The convertible coupe frames have X-members as formerly, to reduce the increased body shake that is inherent in this model and improve frame to body attachment. A frame to rear axle control strut is continued for the Imperial Models. (See Paragraph 8, "Universal Joint", Section XII, for adjustment procedures).

1. CHECKING FRAME DIMENSIONS

In case of collision, frame members can often be satisfactorily straightened to the required dimensional limits. In case of serious damage or fracture to front crossmembers, upper and lower control arms and steering knuckle, the component parts, ball joints and steering arms should be replaced.

CAUTION

Under no circumstances should the control arms, knuckles, steering arms or torsion bars be heated for straightening. Heating these parts will anneal the metal and lower their strength to a point which will make them dangerously weak for further use.

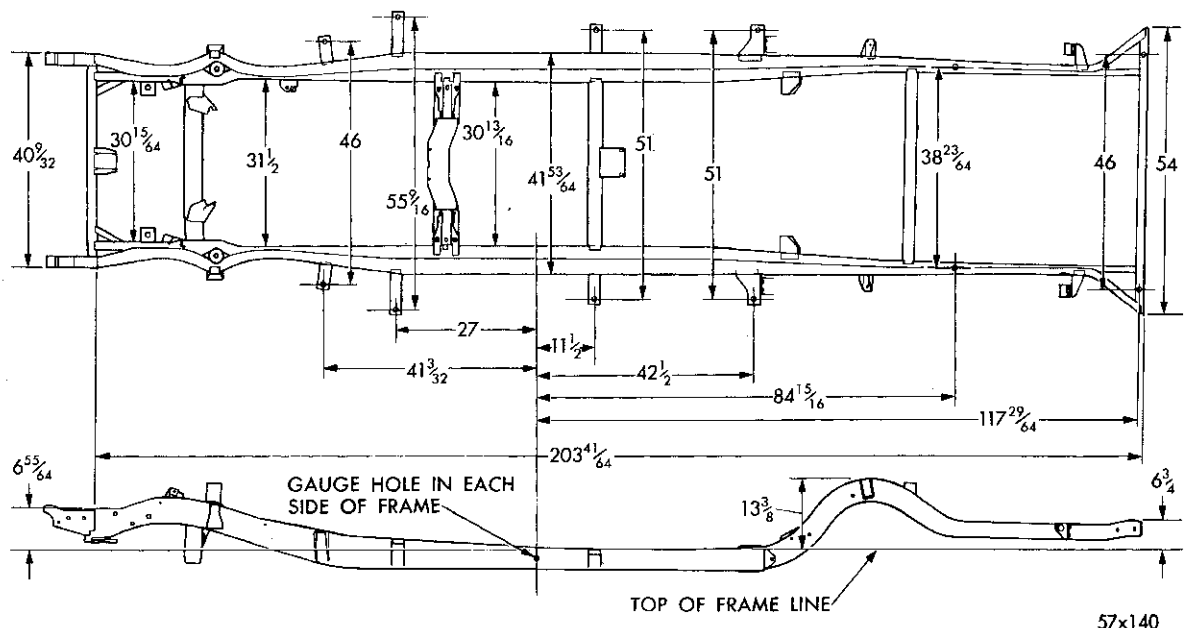

Fig. 2—Frame Dimensions, Imperial

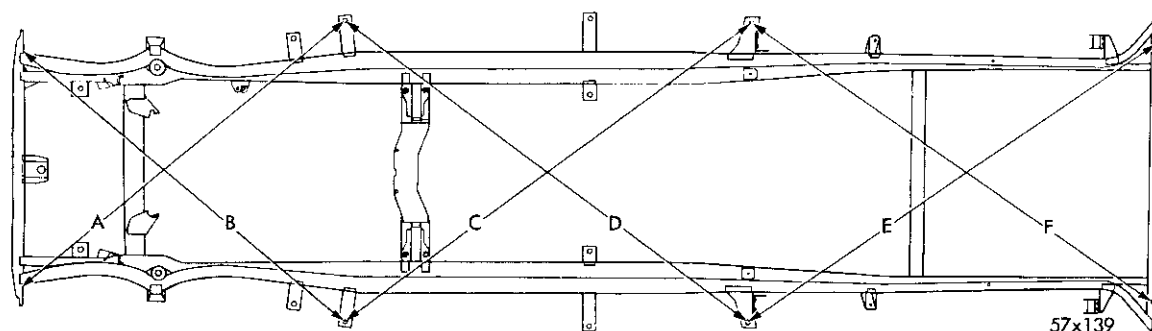

Fig. 3—Typical Frame Diagonal Measurements

Before a member is replaced, it is essential that frame alignment be checked and corrected if necessary. Whenever possible, parts should be securely fastened with hot rivets. In cases where no riveting equipment is available, finished bolts snugly fitted in reamed holes may be used. The nuts should be securely tightened and non-spreading lockwashers used. (Cold rivets are not recommended unless adequate power press equipment is available to do a secure riveting job.) When welding frame members, care must be taken to localize the heat so that the steel hardness of frame will be retained. Reinforcement welds should run lengthwise, along side of reinforcement.

Figures 1, 2, and 3 show various dimensions to be used as a guide for checking frame alignment. These dimensions are the true distance between two points as measured with a steel tape.

Figure 3 shows a few of various measurements that may be taken to check "squareness" of frame. Diagonal measure will quickly determine which section of frame is bent and where force should be applied to restore correct alignment.

2. FRAME ALIGNMENT

To properly check a frame for alignment, diagonal measurement should be performed with great care. When body is removed, the frame may be easily checked for alignment by measur-

ing diagonals, as shown in Figure 3, with tram-mels or steel tape and check dimensions given in Figs. 1, 2 and 3. Measurements may be taken without removing body from chassis by using plumb-bob and chalk line on level floor.

Attach line of plumb-bob to one of rear body bolts. The plumb-bob should be suspended slightly above floor. When plumb-bob comes to rest, mark floor directly underneath it. The marks made on floor will represent various points of frame to be checked diagonally. Move car away so the distance can be measured to compare with the diagonal measurements, shown in Figures 1, 2 and 3.

3. REPLACING BODY SUPPORT BRACKETS

The body support brackets are welded to frame in manufacturing. Due to "Box" construction of frame, rivets cannot be used to attach a new body bracket to frame.

Cut damaged bracket off frame, file surface smooth. Clamp new bracket in correct position and weld securely to frame member. The shielded arc-weld method is recommended for frame welding, or replacement of body frame support brackets. The heat generated from welding operation is localized and burning of material is held to a minimum when a mild steel welding rod is used. Install body bolt and washers, insulator and nut. Tighten to 18 foot-pounds torque. On Convertibles, install a solid spacer, bolt and nut, and tighten securely.

SPRINGS

The rear springs (Fig. 4) are of the semi-elliptical design. The front ends of rear springs are

mounted outboard of the frame side rails and attached to hangers. (See Fig. 5).

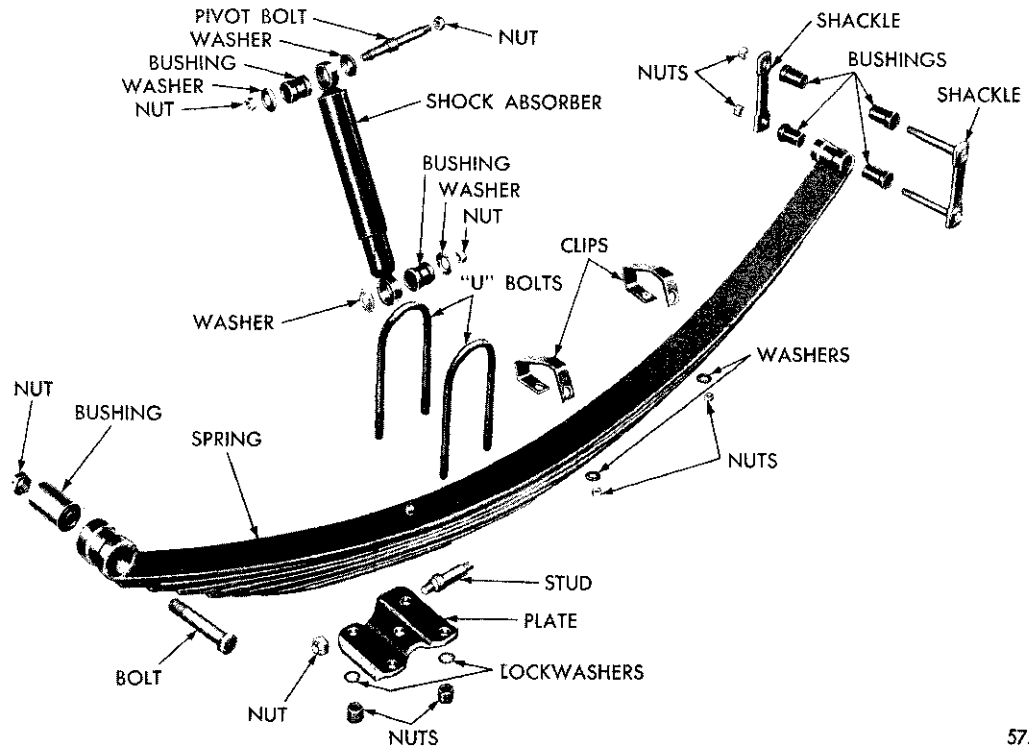

57x68

Fig. 4—Typical Rear Springs Suspension (Disassembled View)

The front and rear spring shackle bolts are cushioned in rubber which tends to reduce road noise to a minimum. (No lubrication is required at the rear shackles.) (See Fig. 6).

To eliminate "spring wind-up" on acceleration an additional spring leaf has been added to front section of rear spring.

The width of spring leaves are 2 1/2 inches (refer to "Data and Specifications"). Thus, with outboard-mounted rear springs, rear-end

roll is greatly reduced and car stability on curves or sharp turns is maintained.

NOTE: Cars equipped with air conditioning units are equipped with a heavier rear spring.

Should it become necessary to install new springs or silent blocks, it will be necessary to remove the rear spring silent block nut bolt and lockwasher to remove rear spring.

4. SPRING MAINTENANCE

It is important that spring "U" bolts be in-

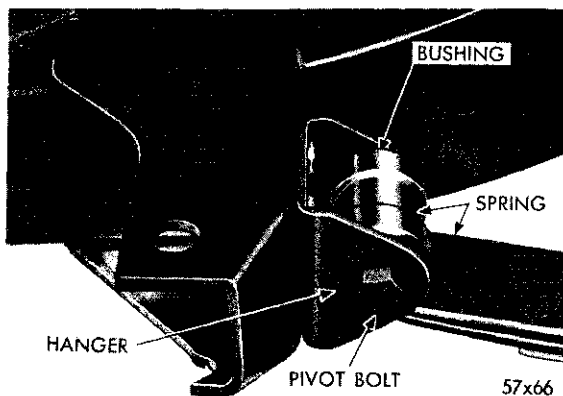

57x66

Fig. 5—Rear Springs Front Mounting

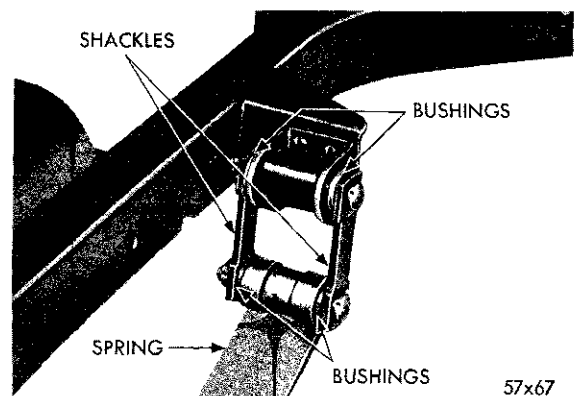

57x67

Fig. 6—Rear Spring Shackles

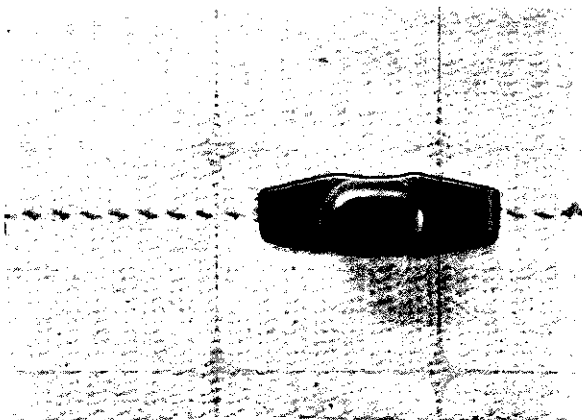

57x505

Fig. 7—Front Interliner

spected at regular intervals and kept tight to prevent spring breakage. Tighten spring "U" bolt nuts to 70 foot-pounds torque. The spring shackles should be inspected occasionally to make sure they are tight, but not binding. Tighten to 50 foot-pounds torque. No lubrication of any kind should be used on rubber bushings.

The height of the car may be affected if rear spring height varies more than $\frac{3}{4}$ inch on one side as compared with other side. To check this, measure vertical distance from top of rear spring main leaf to underside of frame side rail on both sides of car. If these distances differ by more than $\frac{3}{4}$ inch, this is an indication that one of rear springs may need to be replaced. This condition could also be due to a bent frame kick-up or an incorrectly welded spring saddle.

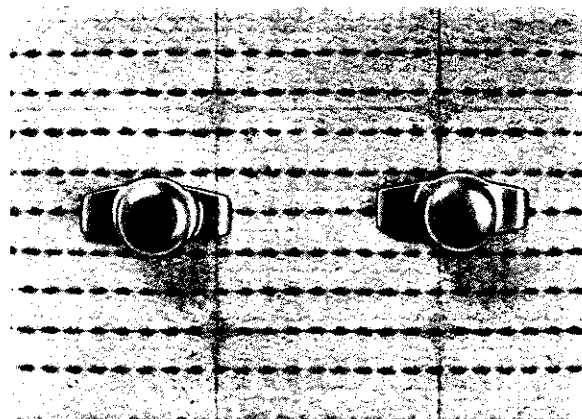

57x506

Fig. 8—Rear Interliner

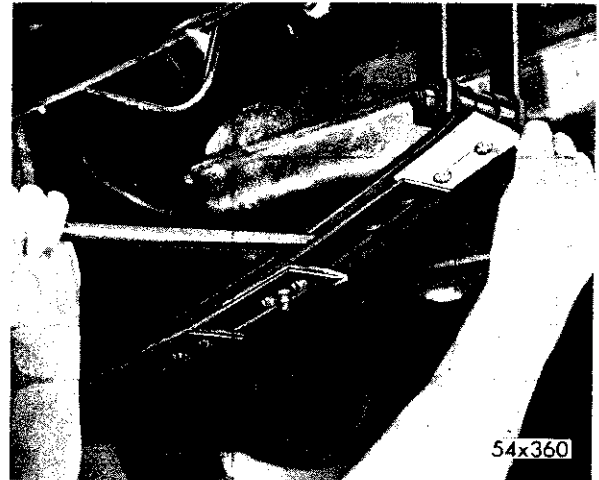

54x360

Fig. 9—Positioning New Interliners

CAUTION

Care should be taken when replacing rear spring on Imperial Models to see that the rear axle housing to frame struts are shimmed properly, so as to maintain correct propeller shaft to axle pinion shaft angle. (See Section XII).

5. REPLACEMENT OF REAR SPRING INTERLINERS

The 1957 Chrysler rear springs are similar to those previously used with exception of rear spring interliners. To replace interliners, proceed as follows: Examine spring interliners (Fig. 7). If any are missing, or if any have lost their metal fasteners, they must be replaced. For replacement of these interliners, proceed as outlined below.



54x361

Fig. 10—Prying Interliner Fastener Through Leaf

a. Removal

Unload rear springs by jacking up the rear end of frame until rear shock absorbers are fully extended. Remove alignment clips from springs. If any of removed parts (nut, bolt, spacer, clip) are damaged, use corresponding replacement parts. Pry out metal fastener directly beneath spring leaf surface and slip out old interliner, after separating the spring leaf to which interliner was fastened from the next longer spring leaf. To effect this separation, pry open the slight gap between leaves with a screwdriver until a tapered bar can be hammered in place between screwdriver and interliner as shown in Figure 8. Keep tapered bar in place.

Clean the lower (grooved) surface of the longer spring leaf as far as interliner makes contact. Use sandpaper wrapped around a flat file and scrub vigorously to remove any dirt or rust spots to obtain smooth metallic surfaces to left and right of groove. Wipe off excess particles, including dirt in groove itself, with a clean cloth. In order to reach between leaves, open gap by bearing down on end of tapered bar.

b. Installation of Interliner

Refer to Fig. 9 and proceed as follows: Slip new interliner in place by opening gap between the spring leaves again with tapered bar and moving interliner until prongs of metal fasteners are aligned with holes in the shorter leaf, as shown in Figure 9. With tapered bar still in

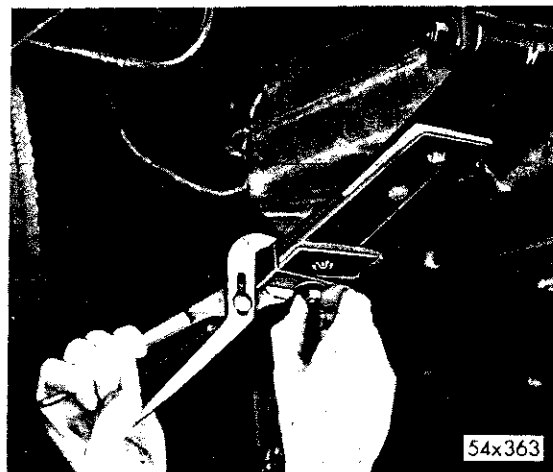

Fig. 11—Tightening Aligning Clip

place, pry prong end of each metal fastener through hole in spring leaf.

Remove tapered bar which has remained between leaves during these operations. The bar may be withdrawn while a screwdriver is placed alongside. Then the screwdriver may be pulled out, reversing operation which was used to insert bar in position. A faster method for withdrawing bar is to insert end of a bar with a short tapered hook alongside the tapered bar. After tapered bar has been withdrawn, the bar with hook can be slipped out easily using leverage motion inward on the far end of hooked bar. Position wrap-around alignment clip and tighten retainer nut, as shown in Figures 10 and 11. Peen end of bolt over nut so it will not loosen.

SHOCK ABSORBER

Chrysler cars are equipped with double acting Oriflow shock absorbers. In the Oriflow shock absorber, resistance is built up slowly at beginning of stroke so as not to jolt passengers. This resistance is increased to a maximum at mid stroke and is tapered off to zero at end of movement. The major part of dampening is accomplished at high velocity mid-operation of stroke where no jolt can originate. There can be little jolt at beginning and at end of stroke because both velocities of movement and the resistance offered by the shock absorber are low at those points.

This simply means that the piston encounters minimum resistance at beginning of stroke and is gradually slowed down by increased resistance due to fluid velocity through the orifices. In turn, slow movement of piston causes fluid velocity to decrease and offer minimum resistance at termination of stroke.

To improve the riding qualities of the 1957 cars the valving of the front shock absorber has been revised to afford more control to spring action under varying road conditions.

6. TESTING ORIFLOW SHOCK ABSORBERS

Oriflow shock absorbers are designed to operate with low resistance when operated slowly and with high resistance when operated rapidly. Since they operate with little resistance when compressed by hand or by bench test methods, their true operating efficiency can only be determined by a road test. It is impossible to determine operating efficiency of Oriflow shock absorbers by rocking the car by the bumper.

When road testing, drive car over a fairly rough road to test resistance under fast shock absorber piston speed. Then drive over a fairly smooth road to test resistance during slower shock absorber piston speeds.

Hand testing Oriflow shock absorbers will only reveal complete failure. The amount of ride control evident from a hand test on bench is small, compared with control exerted under actual riding conditions. For this reason, it is impossible to feel any sudden resistance in an Oriflow shock absorber, no matter how fast it is operated by hand.

7. SERVICING THE ORIFLOW SHOCK ABSORBER

The Oriflow shock absorber cannot be refilled or disassembled. Where servicing is required, the shock must be removed and a new unit installed. **SHOCK ABSORBERS SHOULD ONLY BE REPLACED IF THEY HAVE LOST THEIR RESISTANCE IN ONE OR BOTH DIRECTIONS OR IF THEY DRIP OIL. EVIDENCE OF OIL MOISTURE IS NOT CAUSE TO REPLACE THEM AS SEAL MUST WEEP TO PREVENT SCORING.**

8. REMOVAL AND INSTALLATION OF FRONT SHOCK ABSORBER**a. Removal**

Refer to Fig. 12 and proceed as follows: From the engine compartment remove dirt and grit from around shock absorber piston rod and upper retainer housing. Remove piston rod nut and retainer washer. Place jack in center of engine front crossmember and raise vehicle off floor. Remove shock absorber to lower control arm bracket attaching nut, bolt and washer. Disengage shock absorber eye from control arm bracket. Push lower portion of absorber up into frame housing sufficiently to clear lower bracket. Remove shock absorber.

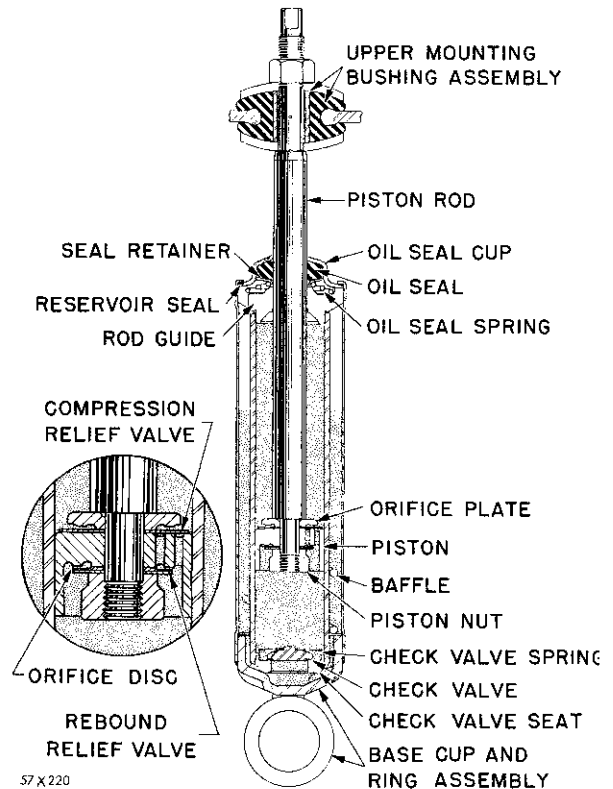

Fig. 12—Front Shock Absorber

NOTE: Care must be taken to see that the lower shock absorber mounting upper washer on the piston shaft is recovered from shock absorber housing when removing the shock absorber.

b. Installation

Place upper mounting retainer washer cupped side up, on shock absorber piston rod. Compress shock absorber piston rod into shock absorber. Insert assembly up through opening in frame to allow piston rod to enter upper housing bushing. While holding in position, install upper mounting retainer washer (cupped side down) and nut. Hold piston rod with suitable wrench and tighten nut to approximately 24 foot-pounds torque or until upper and lower mounting washer contacts steel spacer in bushing. Position lower end of shock absorber in lower control arm mounting bracket, install attaching bolt, nut and lockwasher, tighten to 40 foot-pounds torque.

9. REPLACING SHOCK ABSORBER PISTON SHAFT UPPER BUSHING

NOTE: The upper bushing should be checked

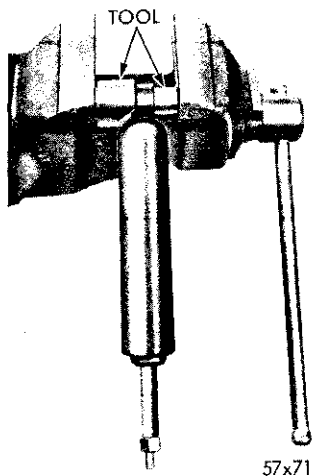

Fig. 13—Installing Shock Absorber Eye Bushing

whenever the shock absorber is removed from car.

a. Removal

If bushing is worn or damaged proceed as follows: Remove bushing inner steel spacer from bushing and with a suitable drift remove piston shaft bushing from frame housing.

b. Installation

Remove inner bushing spacer from replacement bushing. Immerse bushing in water (do not use brake fluid, soap or other alkaline fluids). Insert bushing in housing and with a twisting motion press bushing in place. Install bushing spacer.

10. REPLACING LOWER SHOCK ABSORBER EYE BUSHING

Remove the lower shock absorber bushing sleeve

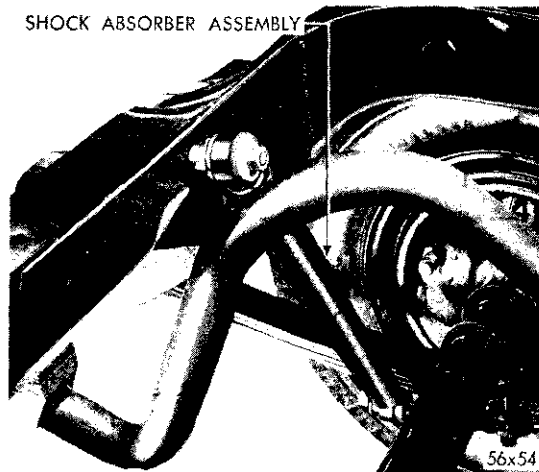

Fig. 14—Rear Shock Absorber Installed

in vise or arbor press as shown in Figure 13.

NOTE: To avoid damaging bushings when installing bushings, press against the steel sleeve.

11. REMOVAL AND INSTALLATION OF REAR SHOCK ABSORBERS (FIG. 14)

To remove rear shock absorber, remove nuts from shock absorber mounting stud pins which pass through eyes at top and bottom of shock absorber, and remove shock absorber.

When installing a shock absorber, install bushings in the shock absorber's eye. Install inner bushing retainers, shock absorber and bushing assembly and outer retainers and nut. The concave face of each retainer must fit against convex face of adjacent bushing. Tighten to specified torque.