

Section V

COOLING SYSTEM

The cooling system incorporates either the cellular or the fin and tube pressure vent radiator and a centrifugal pump.

1. WATER PUMP REMOVAL (See Fig. 1.)

Drain cooling system and remove radiator inlet hose and heater hoses. Remove fan shroud and disconnect wire at temperature gauge sending unit. Remove generator, fan assembly, idler pulley and belts. Remove oil cooler (if so equipped). Remove water pump housing attaching bolts and water pump housing.

2. WATER PUMP DISASSEMBLY

Remove the cover plate and gasket. Place water pump in a suitable fixture to permit leveling the pump (impeller side up) and press out bearing and shaft assembly from impeller, as shown in Figure 2.

CAUTION

The bearing can only be removed from front of pump. To remove the shaft in the opposite direction will damage the water pump body.

Remove lock ring at impeller and remove retaining washer and seal assembly. Remove fan hub from shaft with puller Tool C-412.

NOTE

Plastic Impellers break when pump is disassembled and cannot be re-used. The impeller insert should be removed from the shaft, before pushing bearing out to prevent damage to the seal seat.

NOTE

Water pump shaft and bearings are serviced as an assembly only.

3. WATER PUMP ASSEMBLY

Clean all parts thoroughly. Inspect pump housing base and machined surfaces for scoring and burrs. Do not re-use a shaft and bearing assembly removed from a water pump as it

will be damaged during disassembly. Assemble a new water thrower (split ring) on the water pump shaft and, using Tool C-3469, press shaft and bearing into water pump housing to depth, as shown in Figure 3.

CAUTION

Pressure must be applied on outer diameter of bearing and not on end of shaft. **DO NOT HAMMER** and **DO NOT** bottom stop collar of tool against water pump body. This tool was not designed to control the depth of the bearing of this particular pump but was designed to accommodate several pumps.

Install a new seal assembly and retainer washer (carbon) into the impeller and retain with lock ring. Support pump on hub end of shaft and install impeller with a suitable sleeve which will direct pressure on metal insert only. **Back face of impeller must be flush with end of shaft.** Support pump shaft on impeller side before pump cover is in place. Press hub into position. Hub is correctly positioned when end of shaft is .380 inch from front end of fan hub. (Refer to Fig. 2). Install hub pin andpeen both ends of pin.

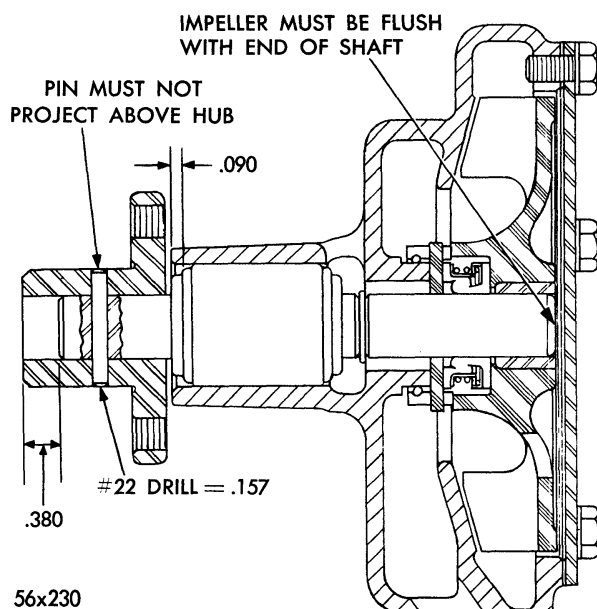
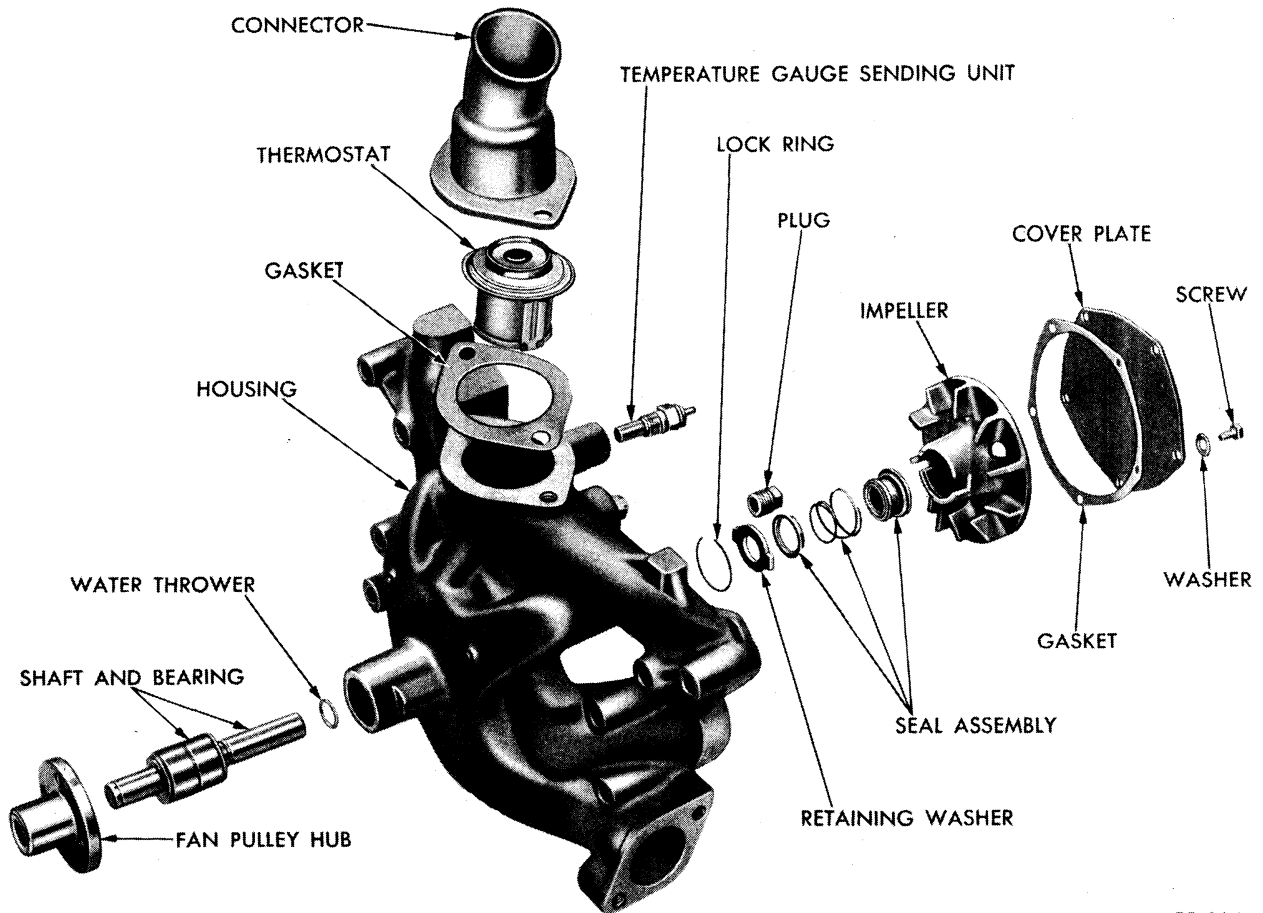

Fig. 1—Water Pump Assembly



55x16A

Fig. 2—Water Pump (Disassembled View)

NOTE

The fan hub must be a tight press fit (.002 inch minimum) on shaft. A hub that has been removed from the shaft should not be used again. Use a new hub.

With fan hub in place, install water pump gasket, cover, attaching screws and sealing washers. Tighten screws securely.

4. WATER PUMP IMPELLER

a. Removal

NOTE

It is not necessary to remove the shaft and bearing assembly from pump housing to remove impeller.

Remove water pump cover, and gasket. Support the pump assembly on the fan end of the

pump shaft and not on the housing. A 1/2 inch plug 1 1/2 inches long inserted in the end of fan

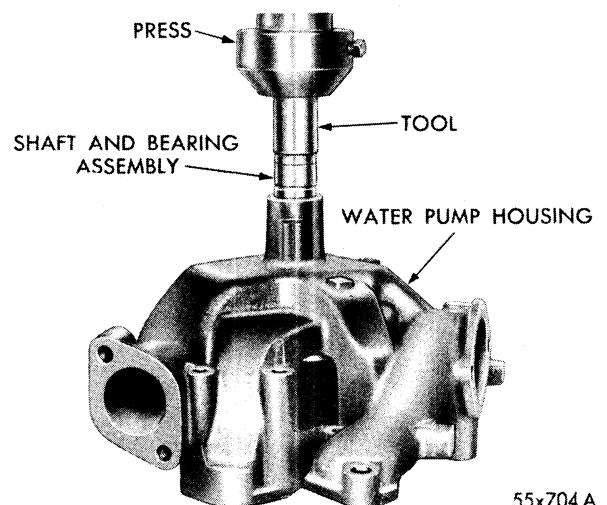

55x704 A

Fig. 3—Installing Pump Shaft and Bearing Assembly

hub so that it butts up against end of shaft, will be suitable. With body and shaft suitably supported, use a cold chisel to break the plastic portion of impeller away from metal insert. (Start near metal insert). Remove parts of seal assembly by sliding them over the shaft and insert. Attach puller, Tool C-3476 and remove metal insert.

b. Installation

Install new seal assembly into new impeller and retain in position with lock ring. With housing supported as for removal of impeller, press impeller on end of shaft. Use a tool which will direct pressure on insert only. Impeller is properly positioned when back face of impeller is flush with end of shaft.

CAUTION

Support the pump housing so that pressure is applied to the end of shaft and not to the bearings and housing. If pressure is applied to the housing, damage to the shaft and bearing assembly will result.

Install new cover gasket, cover, sealing washers and attaching screws.

5. WATER PUMP INSTALLATION

Use new gaskets and install water pump assembly. Tighten bolts 30 foot-pounds torque. Install fan, pulleys and belts. Adjust belts, as shown in Figure 4. Install hoses, tempera-

1/4 INCH DEFLECTION FROM STRAIGHT LINE BETWEEN PULLEYS

GENERATOR ADJUSTING STRAP BOLT

IDLER PULLEY ADJUSTING BOLT

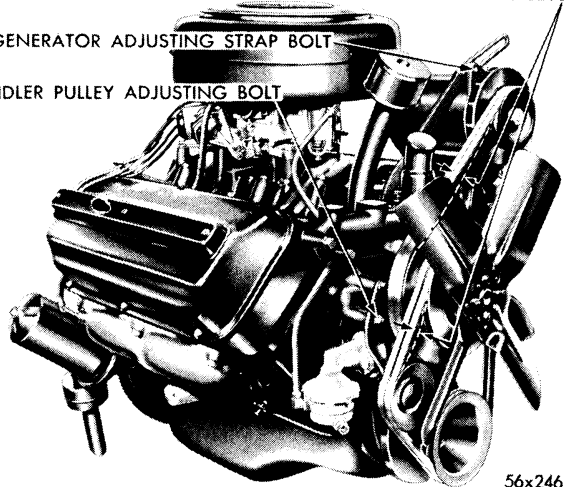

Fig. 4—Fan Belt Adjustment (FirePower)
(Typical of Spitfire)

ture sending unit wire and install fan shroud. Refill the cooling system and check for leaks.

6. RADIATOR

a. Removal

Drain the cooling system, remove hoses, fan shroud and radiator support bolts. Remove radiator.

b. Installation

Attach radiator to radiator support, install fan shroud, connect hoses and refill cooling system, and check for leaks.

c. Cleaning Radiator

Drain cooling system and refill with clean SOFT water and the contents of one can (No. 1 top-compartment) of MOPAR Cooling System Cleaner. Run engine at a fast idle for 1/2 to 3/4 hour. Drain cooling system and refill with clean water. Pour conditioner (No. 2 bottom-compartment) into radiator and run engine for ten minutes. Flush entire cooling system until water runs clean. Refill radiator with clean SOFT water. Use MOPAR Radiator Rust Inhibitor during the summer months.

7. REVERSE FLUSHING

Reverse flushing of the cooling system is the forcing of water through the cooling system, using air pressure, in a direction opposite to that of the normal flow of water.

a. Cylinder Block

Drain radiator and remove hoses at radiator. Remove thermostat and reinstall thermostat housing. Install flushing gun Tool C-311, or other suitable flushing gun to the inlet hose. Connect water hose of gun to a pressure water source and the air hose of gun to a pressure air source. Turn on water, and when cylinder block is filled, turn on the air in short blasts. Allow cylinder block to fill between the blasts of air. Continue this procedure until water runs clean. Check thermostat and if satisfactory, reinstall; otherwise, replace. Use a new thermostat housing gasket. Refill cooling system.

b. Radiator

Drain cooling system and remove hoses from

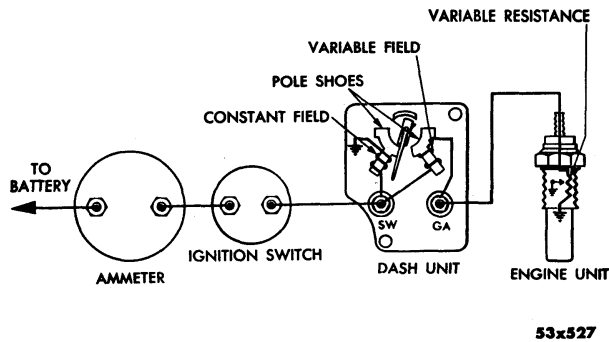

Fig. 5—Water Temperature Gauge

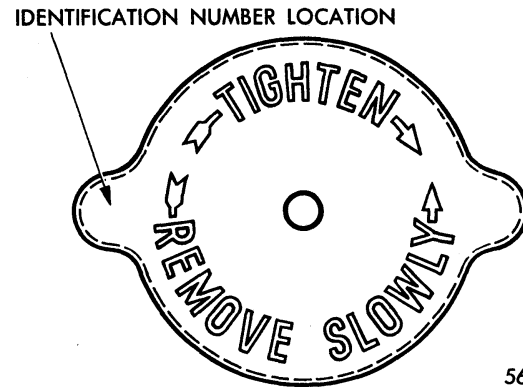

Fig. 6—Radiator Pressure Cap

engine. Install flushing gun Tool C-311, or other suitable flushing gun in radiator outlet hose. Fill radiator and turn on air in short blasts.

NOTE

Do not apply excessive pressure when pressure flushing radiator, as damage to radiator may result.

Continue this procedure until water runs clean. Refill cooling system. Run engine and check for leaks.

8. WATER TEMPERATURE GAUGE (Fig. 5)

a. Dash Unit

Consists of two electro-magnets, one connected to the ignition switch and a ground holds the gauge pointer to (C) cold position when ignition switch is turned on and the other connected to a ground in the engine registers the water temperature.

b. Sending Unit

The sending unit is located in the water pump housing and transmits the water temperature to dash unit.

c. Electrical Circuit (Testing)

Remove wire at sending unit and turn ignition switch on. Gauge hand should not move. If hand

moves, the wire is grounded or gauge is defective. Remove wire at dash gauge terminal "GA", and if hand still moves, replace dash gauge; otherwise, replace wire. If gauge operates correctly and wire is not grounded, replace the engine unit.

9. THERMOSTAT (Testing)

The thermostat starts to open at 160 to 165 degrees F. and is fully opened at 189 degrees. Place thermostat in a pail of water with a thermometer and heat water until thermostat starts to open. Check thermometer and continue heating until thermostat is wide open, and again check thermometer. Replace thermostats that do not open completely, open at too low temperature or open at too high temperature.

10. RADIATOR PRESSURE CAP

Radiators are equipped with a standard seven psi cap, as shown in Figure 6. Cars equipped with air conditioning use a 14 psi cap. Always check identification number on cap, when replacing.

WARNING

When removing pressure cap, turn it counterclockwise to the stop, permitting built up pressure to escape through overflow tube. This will prevent hot water from spraying out of radiator filler opening.

SERVICE DIAGNOSIS

11. POOR CIRCULATION

- a. Check for low coolant level and refill to $1\frac{1}{4}$ inches below filler neck.
- b. Inspect and replace hoses if collapsed.
- c. Check for plugged radiator or cylinder block and reverse flush as necessary.
- d. Check for loose water pump impeller and repair as necessary.
- e. Check for loose or defective fan belt, tighten or replace as necessary.

12. OVERHEATING

- a. Refer to Poor Circulation listed in Paragraph 11.

- b. Check for plugged air passages of radiator coil and clean passages by applying air pressure on reverse side of radiator case.

- c. Check for sticking thermostat and replace as necessary.

- d. Check for excessive sludge in the crankcase. Drain and flush crankcase as necessary. In severe cases, remove oil pan and clean inside of block by hand.

13. OVERCOOLING

- a. Check temperature gauges and replace as necessary.

- b. Check operation of thermostat (could be sticking) in the closed position.
